

Failing function codes, failing items and symbolic FRUs



ESCALA

Failing function codes, failing items and symbolic FRUs

Hardware

May 2009

BULL CEDOC
357 AVENUE PATTON
B.P.20845
49008 ANGERS CEDEX 01
FRANCE

REFERENCE
86 A1 99FA 01

The following copyright notice protects this book under Copyright laws which prohibit such actions as, but not limited to, copying, distributing, modifying, and making derivative works.

Copyright © Bull SAS 2009

Printed in France

Trademarks and Acknowledgements

We acknowledge the rights of the proprietors of the trademarks mentioned in this manual.

All brand names and software and hardware product names are subject to trademark and/or patent protection.

Quoting of brand and product names is for information purposes only and does not represent trademark misuse.

The information in this document is subject to change without notice. Bull will not be liable for errors contained herein, or for incidental or consequential damages in connection with the use of this material.

Contents

Safety notices	xxi
---------------------------------	------------

Failing function codes, failing items, and symbolic FRUs	1
---	----------

PDF files for failing function codes, failing items, and symbolic FRUs	1
Failing function codes, failing items, and symbolic FRUs	1
Failing function codes	1
Failing function code 11A	1
Failing function code 132	2
Failing function code 141	2
Failing function code 151	2
Failing function code 152	2
Failing function code 153	2
Failing function code 159	3
Failing function code 165	3
Failing function code 166	3
Failing function code 167	4
Failing function code 169	4
Failing function code 185	4
Failing function code 186	4
Failing function code 188	5
Failing function code 190	5
Failing function code 192	5
Failing function code 199	5
Failing function code 201	6
Failing function code 203	6
Failing function code 210	6
Failing function code 212	7
Failing function code 214	7
Failing function code 217	8
Failing function code 219	8
Failing function code 221	9
Failing function code 226	9
Failing function code 227	9
Failing function code 240	9
Failing function code 241	10
Failing function code 2502	10
Failing function code 2503	10
Failing function code 2504	10
Failing function code 2505	11
Failing function code 251	11
Failing function code 2512	11
Failing function code 2513	11
Failing function code 2514	12
Failing function code 2515	12
Failing function code 2516	12
Failing function code 2517	12
Failing function code 2518	12
Failing function code 252	12
Failing function code 2520	12
Failing function code 2521	13
Failing function code 2522	13
Failing function code 2523	13
Failing function code 2524	14
Failing function code 2525	15
Failing function code 2526	15

Failing function code 2527	15
Failing function code 2528	16
Failing function code 2529	16
Failing function code 252B	16
Failing function code 252D	16
Failing function code 252E	17
Failing function code 253	17
Failing function code 2530	17
Failing function code 2531	17
Failing function code 2532	17
Failing function code 2533	18
Failing function code 2534	18
Failing function code 2535	18
Failing function code 2537	18
Failing function code 2538	19
Failing function code 254	19
Failing function code 254E	19
Failing function code 2550	19
Failing function code 2551	20
Failing function code 2555	20
Failing function code 2556	20
Failing function code 2557	20
Failing function code 256	20
Failing function code 2562	20
Failing function code 2564	20
Failing function code 2566	21
Failing function code 2568	21
Failing function code 256D	21
Failing function code 256E	21
Failing function code 257	21
Failing function code 2570	22
Failing function code 2571	22
Failing function code 2572	22
Failing function code 258	22
Failing function code 2580	22
Failing function code 2581	23
Failing function code 2583	23
Failing function code 2586	23
Failing function code 2587	24
Failing function code 2588	24
Failing function code 259	24
Failing function code 2590	24
Failing function code 2591	25
Failing function code 2592	25
Failing function code 2593	25
Failing function code 25A0	25
Failing function code 25B9	25
Failing function code 25C0	26
Failing function code 25C1	26
Failing function code 25C2	26
Failing function code 25C3	26
Failing function code 25C4	26
Failing function code 25D0	27
Failing function code 25D2	27
Failing function code 25F8	27
Failing function code 260	27
Failing function code 2600	27
Failing function code 2601	28
Failing function code 2602	28
Failing function code 2603	28
Failing function code 2604	28

Failing function code 261	28
Failing function code 2611	28
Failing function code 2612	29
Failing function code 2613	29
Failing function code 2614	29
Failing function code 2615	29
Failing function code 2616	29
Failing function code 2617	29
Failing function code 2618	30
Failing function code 262	30
Failing function code 263	30
Failing function code 2631	30
Failing function code 2640	30
Failing function code 2641	31
Failing function code 2642	31
Failing function code 2643	31
Failing function code 2644	31
Failing function code 2645	31
Failing function code 2646	32
Failing function code 2647	32
Failing function code 2648	32
Failing function code 2649	32
Failing function code 264B	32
Failing function code 264D	33
Failing function code 264E	33
Failing function code 2650	33
Failing function code 2651	33
Failing function code 2653	33
Failing function code 2654	33
Failing function code 2655	34
Failing function code 2658	34
Failing function code 2659	34
Failing function code 265B	34
Failing function code 266	34
Failing function code 2667	35
Failing function code 267	35
Failing function code 2680	35
Failing function code 2681	35
Failing function code 271	35
Failing function code 272	36
Failing function code 273	36
Failing function code 276	36
Failing function code 277	36
Failing function code 279	37
Failing function code 282	37
Failing function code 287	37
Failing function code 289	37
Failing function code 292	37
Failing function code 293	38
Failing function code 294	38
Failing function code 295	38
Failing function code 296	38
Failing function code 297	39
Failing function code 298	39
Failing function code 2C3	39
Failing function code 2C4	39
Failing function code 2C5	40
Failing function code 2C6	40
Failing function code 2C7	40
Failing function code 2C8	41
Failing function code 2C9	41

Failing function code 2CC	41
Failing function code 2CD	41
Failing function code 2CE	42
Failing function code 2D0	42
Failing function code 2D00	42
Failing function code 2D01	43
Failing function code 2D02	43
Failing function code 2D03	43
Failing function code 2D05	43
Failing function code 2D07	43
Failing function code 2D0B	43
Failing function code 2D1	44
Failing function code 2D2	44
Failing function code 2D3	44
Failing function code 2D4	44
Failing function code 2D5	45
Failing function code 2D6	45
Failing function code 2D7	45
Failing function code 2D9	45
Failing function code 2E0	45
Failing function code 2E01	45
Failing function code 2E02	45
Failing function code 2E03	45
Failing function code 2E1	46
Failing function code 2E2	46
Failing function code 2E3	46
Failing function code 2E4	46
Failing function code 2E6	46
Failing function code 2E7	46
Failing function code 2E8	47
Failing function code 2E12	47
Failing function code 301	47
Failing function code 302	47
Failing function code 303	47
Failing function code 304	47
Failing function code 305	47
Failing function code 306	48
Failing function code 307	48
Failing function code 308	48
Failing function code 30A	48
Failing function code 30B	48
Failing function code 440	48
Failing function code 441	49
Failing function code 442	49
Failing function code 443	49
Failing function code 444	49
Failing function code 445	49
Failing function code 446	49
Failing function code 447	50
Failing function code 451	50
Failing function code 453	50
Failing function code 458	50
Failing function code 459	50
Failing function code 541	50
Failing function code 542	50
Failing function code 56B	51
Failing function code 56D	51
Failing function code 57B	51
Failing function code 57D	51
Failing function code 58B	51
Failing function code 58D	51

Failing function code 59B.	51
Failing function code 601.	52
Failing function code 60B.	52
Failing function code 613.	52
Failing function code 61B.	52
Failing function code 61D.	52
Failing function code 61E.	52
Failing function code 621.	53
Failing function code 623.	53
Failing function code 624.	53
Failing function code 62D.	53
Failing function code 62E.	53
Failing function code 636.	54
Failing function code 637.	54
Failing function code 638.	54
Failing function code 639.	54
Failing function code 63A.	54
Failing function code 63B.	54
Failing function code 63C.	54
Failing function code 63D.	55
Failing function code 63E.	55
Failing function code 63F.	55
Failing function code 640.	55
Failing function code 643.	55
Failing function code 644.	55
Failing function code 646.	55
Failing function code 64A.	56
Failing function code 64B.	56
Failing function code 64C.	56
Failing function code 64D.	56
Failing function code 64E.	56
Failing function code 64F.	57
Failing function code 650.	57
Failing function code 653.	57
Failing function code 655.	57
Failing function code 657.	57
Failing function code 65A.	58
Failing function code 65B.	58
Failing function code 65E.	58
Failing function code 65F.	58
Failing function code 662.	58
Failing function code 663.	58
Failing function code 664.	58
Failing function code 667.	59
Failing function code 669.	59
Failing function code 66A.	59
Failing function code 66C.	59
Failing function code 66D.	59
Failing function code 66E.	60
Failing function code 670.	60
Failing function code 671.	60
Failing function code 672.	60
Failing function code 673.	60
Failing function code 674.	60
Failing function code 675.	60
Failing function code 677.	61
Failing function code 678.	61
Failing function code 679.	61
Failing function code 67B.	61
Failing function code 67E.	61
Failing function code 681.	62

Failing function code 682	62
Failing function code 683	62
Failing function code 684	62
Failing function code 685	62
Failing function code 686	63
Failing function code 687	63
Failing function code 689	63
Failing function code 68C	63
Failing function code 68E	63
Failing function code 690	64
Failing function code 691	64
Failing function code 692	64
Failing function code 693	64
Failing function code 697	65
Failing function code 698	65
Failing function code 699	65
Failing function code 69B	65
Failing function code 69D	65
Failing function code 6C9	66
Failing function code 6CC	66
Failing function code 700	66
Failing function code 701	66
Failing function code 702	67
Failing function code 703	67
Failing function code 704	67
Failing function code 705	67
Failing function code 706	68
Failing function code 707	68
Failing function code 709	68
Failing function code 711	68
Failing function code 713	69
Failing function code 716	69
Failing function code 717	69
Failing function code 721	69
Failing function code 722	69
Failing function code 723	69
Failing function code 724	69
Failing function code 725	70
Failing function code 726	71
Failing function code 727	71
Failing function code 728	71
Failing function code 730	71
Failing function code 733	71
Failing function code 734	71
Failing function code 736	72
Failing function code 741	72
Failing function code 742	72
Failing function code 745	72
Failing function code 746	73
Failing function code 747	73
Failing function code 749	73
Failing function code 74A	73
Failing function code 750	73
Failing function code 751	74
Failing function code 757	74
Failing function code 759	74
Failing function code 763	74
Failing function code 764	75
Failing function code 772	75
Failing function code 773	75
Failing function code 774	75

Failing function code 775	75
Failing function code 776	76
Failing function code 777	76
Failing function code 778	76
Failing function code 77B	76
Failing function code 77C	76
Failing function code 780	76
Failing function code 781	77
Failing function code 783	77
Failing function code 784	77
Failing function code 785	78
Failing function code 786	78
Failing function code 787	78
Failing function code 788	78
Failing function code 789	78
Failing function code 78B	79
Failing function code 78D	79
Failing function code 790	79
Failing function code 791	79
Failing function code 792	79
Failing function code 793	80
Failing function code 795	80
Failing function code 799	80
Failing function code 7C0	80
Failing function code 7C1	81
Failing function code 804	81
Failing function code 806	81
Failing function code 807	81
Failing function code 80C	82
Failing function code 811	82
Failing function code 812	82
Failing function code 814	82
Failing function code 815	82
Failing function code 816	83
Failing function code 817	83
Failing function code 820	83
Failing function code 821	83
Failing function code 823	84
Failing function code 824	84
Failing function code 825	84
Failing function code 826	84
Failing function code 827	85
Failing function code 828	85
Failing function code 82C	85
Failing function code 830	86
Failing function code 831	86
Failing function code 836	86
Failing function code 837	86
Failing function code 840	87
Failing function code 844	87
Failing function code 845	87
Failing function code 846	87
Failing function code 84A	88
Failing function code 868	88
Failing function code 887	88
Failing function code 891	88
Failing function code 892	88
Failing function code 893	89
Failing function code 894	89
Failing function code 899	89
Failing function code 89C	89

Failing function code 900	90
Failing function code 901	90
Failing function code 902	90
Failing function code 903	90
Failing function code 904	90
Failing function code 905	90
Failing function code 908	91
Failing function code 912	91
Failing function code 913	91
Failing function code 914	92
Failing function code 915	92
Failing function code 917	92
Failing function code 918	92
Failing function code 921	93
Failing function code 922	93
Failing function code 923	96
Failing function code 925	96
Failing function code 926	96
Failing function code 927	96
Failing function code 929	97
Failing function code 930	97
Failing function code 935	97
Failing function code 938	97
Failing function code 946	98
Failing function code 947	98
Failing function code 950	98
Failing function code 951	98
Failing function code 952	99
Failing function code 953	99
Failing function code 954	100
Failing function code 955	100
Failing function code 956	100
Failing function code 959	101
Failing function code 960	101
Failing function code 962	101
Failing function code 963	102
Failing function code 964	102
Failing function code 966	102
Failing function code 968	102
Failing function code 970	103
Failing function code 971	103
Failing function code 972	103
Failing function code 973	104
Failing function code 974	104
Failing function code 980	104
Failing function code 981	104
Failing function code 982	104
Failing function code 983	105
Failing function code 984	105
Failing function code 986	105
Failing function code 987	105
Failing function code 989	105
Failing function code 990	106
Failing function code 991	106
Failing function code 992	106
Failing function code 993	106
Failing function code 994	106
Failing function code 995	106
Failing function code 998	107
Failing function code 999	107
Failing function code B08	107

Failing function code B09	107
Failing function code B10	108
Failing function code B31	108
Failing function code B3A	108
Failing function code B54	108
Failing function code B69	109
Failing function code B71	109
Failing function code B72	109
Failing function code B73	109
Failing function code B74	109
Failing function code B77	110
Failing function code B81	110
Failing function code B82	110
Failing function code B83	110
Failing function code B88	110
Failing function code C11	112
Failing function code C22	112
Failing function code C24	112
Failing function code C33	113
Failing function code C34	113
Failing function code C35	113
Failing function code C36	113
Failing function code C44	113
Failing function code C45	114
Failing function code C46	114
Failing function code C47	114
Failing function code C48	114
Failing function code C94	114
Failing function code C95	115
Failing function code C97	115
Failing function code C98	115
Failing function code D01	116
Failing function code D06	117
Failing function code D07	117
Failing function code D08	117
Failing function code D46	117
Failing function code D50	118
Failing function code D56	118
Failing function code D57	118
Failing function code D59	119
Failing function code D60	119
Failing function code D66	119
Failing function code D67	119
Failing function code D68	119
Failing function code D69	120
Failing function code D70	120
Failing function code D71	120
Failing function code D72	120
Failing function code D73	120
Failing function code D74	121
Failing function code D75	121
Failing function code D76	121
Failing function code D77	121
Failing function code D78	121
Failing function code D83	122
Failing function code D84	122
Failing function code D85	122
Failing function code D86	122
Failing function code D87	122
Failing function code D88	123
Failing function code D89	123

Failing function code D90	123
Failing function code D91	123
Failing function code D92	123
Failing function code D93	124
Failing function code D94	124
Failing function code D95	124
Failing function code D96	124
Failing function code D97	124
Failing function code E10	125
Failing function code E11	125
Failing function code E12	125
Failing function code E13	125
Failing function code E14	126
Failing function code E15	126
Failing function code E16	126
Failing function code E17	126
Failing function code E18	126
Failing function code E19	127
Failing function code E1A	127
Failing function code E22	127
Failing function code E23	127
Failing function code E24	127
Failing function code E26	127
Failing function code E29	128
Failing function code E2A	128
Failing function code E30	128
Failing function code E3A	128
Failing function code Exx	129
Failing function code Fxx	129
Failing items	129
FI00015	129
FI00017	129
FI00020	129
FI00021	129
FI00022	129
FI00040	130
FI00047	130
FI00050	130
FI00055	130
FI00056	130
FI00057	130
FI00060	130
FI00062	130
FI00065	130
FI00070	130
FI00072	131
FI00090	131
FI00092	131
FI00096	131
FI00098	132
FI00099	132
FI00121	132
FI00122	132
FI00123	132
FI00124	132
FI00130	133
FI00131	133
FI00132	133
FI00141	133
FI00142	133
FI00180	133

FI00182	133
FI00185	133
FI00186	134
FI00187	134
FI00189	134
FI00200	134
FI00203	134
FI00204	134
FI00205	134
FI00206	135
FI00230	135
FI00235	135
FI00236	135
FI00237	135
FI00238	135
FI00239	135
FI00240	135
FI00244	135
FI00245	136
FI00246	136
FI00248	136
FI00253	136
FI00255	136
FI00256	136
FI00300	136
FI00301	137
FI00302	137
FI00310	137
FI00315	137
FI00316	137
FI00317	137
FI00318	138
FI00319	138
FI00320	138
FI00350	138
FI00360	138
FI00380	139
FI00500	139
FI00580	139
FI00581	139
FI00584	140
FI00601	140
FI00602	140
FI00603	140
FI00604	140
FI00605	140
FI00606	140
FI00607	140
FI00608	140
FI00610	141
FI00611	141
FI00612	141
FI00613	141
FI00614	141
FI00615	141
FI00616	141
FI00626	141
FI00630	141
FI00631	142
FI00632	142
FI00700	142

FI00701	142
FI00702	142
FI00703	142
FI00704	142
FI00705	142
FI00708	143
FI00709	143
FI00710	143
FI00711	143
FI00712	143
FI00716	143
FI00717	144
FI00718	144
FI00719	144
FI00720	144
FI00721	144
FI00722	144
FI00723	144
FI00725	144
FI00726	145
FI00727	145
FI00728	145
FI00730	145
FI00731	145
FI00732	145
FI00733	145
FI00734	145
FI00735	145
FI00741	145
FI00742	146
FI00751	146
FI00810	146
FI00830	146
FI00832	146
FI00841	146
FI00842	146
FI00844	146
FI00845	146
FI00850	146
FI00851	147
FI00856	147
FI00870	147
FI00871	147
FI00872	148
FI00880	148
FI00882	148
FI00883	149
FI00884	149
FI01040	149
FI01101	149
FI01103	149
FI01104	149
FI01105	149
FI01106	149
FI01107	150
FI01108	150
FI01109	150
FI01110	150
FI01112	150
FI01117	151
FI01119	151

FI01121	151
FI01130	151
FI01131	151
FI01132	151
FI01140	151
FI01141	151
FI01201	152
FI01202	152
FI01203	152
FI02092	152
FI02112	152
Symbolic FRUs	153
ACMODUL	153
AIRMOVR	154
AJDG301	155
AJDGP01	155
AJEDA00	155
AJEGP01	156
AJEQU00	156
AJGAM01	156
AJGDF01	156
AJGFN00	156
AJGJ601	156
AJGJQ01	156
AJGLD01	156
AJGW701	156
AJLAF01	156
AJLAG01	156
AJLYC01	156
AJLYD01	157
AJSDJ01	157
ALTMANL	157
AMBTEMP	157
AMBTMP1	158
AMBTMP2	159
ANYBRDG	159
ANYBUS	159
ANYFC	159
ANYPROC	159
AS4NTDD	160
AUXCBL	160
AUXIOA	160
BACKPLN	160
BATCHGR	161
BATRY	161
BPC	161
BPCHANG	162
BRDGSET	163
BRDGST1	164
BRDGST2	165
BRDGST3	166
BSTWRPL	168
BUSVPD	168
CABLCONT	168
CABLEH	168
CACHBAT	170
CACHE	170
CAPACTY	170
CARDFLT	170
CARDTMP	173
CBLALL	173

CBLCONT	176
CDAWKLD	176
CDTRAY	177
CHECK	177
CLCKMOD	177
CLNTSRC	177
CLRNVRM	178
CMPRES1	178
CNVTCRD	178
CRYPBAT	179
CRYPTLP	179
CTLPNCD	179
CTLPNL	180
CTPLPDU	180
CTPNADR	180
DCA	180
DEVBPLN	181
DEVICE	182
DEVTERM	183
DIMM 0	183
DIMM 1	184
DIMM 2	184
DIMM2_3	185
DIMM 3	185
DIMM0_1	186
DISKDRV	186
DISKFAN	186
DISKIMG.	187
DISKPWR	187
DSKUNIT	188
DPAC	188
DRVSWCH	188
DISKTRY.	188
EACODE.	189
EXTREMD	189
EXTSCSI	189
FCCABLE	191
FCCODE	191
FCDEV	191
FCGATE	191
FCINTF	192
FCIOA	192
FCPORT	192
FRPORT	194
FWADIPL	197
FWCD1	197
FWCD2	198
FWCONS.	198
FWENET	199
FWFLASH	199
FWFWPBL	199
FWHANG	199
FWHOST.	199
FWIDE1	200
FWIDE2	200
FWIPIPL	200
FWLPAR	200
FWMBOOT	201
FWNIM	201
FWNVR1.	201
FWNVR2.	202

FWNVR3	202
FWPCI1	203
FWPCI2	203
FWPCI3	204
FWPCI4	205
FWPCI5	206
FWPCI6	206
FWPTR	207
FWPWD	207
FWRIPL	208
FWSCSI1	208
FWSCSI2	209
FWSCSI3	209
FWSCSI4	209
FWSCSI5	210
FWSCSIH	210
FWVTHMC	210
HCA	211
HEA	211
HMCLIC	212
HMCMTWK	212
HMCNTWK	212
HSL1	213
HSL1_UN	213
HSL2	213
HSL2_01	213
HSL2_03	213
HSL2_08	213
HSL2_10	214
HSL2_15	214
HSL2_17	214
HSL2_25	214
HSL2_xx	214
HSL_I2	214
HSL_I3	215
HSL_I4	215
HSL_I5	215
HSL_I	215
HSL_IB	215
HSL_Ix	215
HSL_LNK	216
HSL_OPT	220
HSLH	220
HSLH_06	220
HSLH_15	220
HSLH_xx	220
I2CBUS	221
IDPART	224
INT_12X	224
IO_DEV	224
IO HUB	227
IOA	227
IOACNFG	227
IOADPTR	228
IOBRDG	230
IOP	231
LBSADP1	231
LBSADP2	231
LBSADP3	231
LBSADP4	232
LBSADP5	232

LBUSADP	232
LIB3494	232
LICCODE	232
LITSTRP	233
LOADCY1	234
LOC_SYS	234
LPARCFG	234
LPARSUP	235
LSERROR	235
MA_BRDG	235
MABRCFG	236
MAILBOX	238
MASBUS	238
MEDIA	239
MEMBRD	239
MEMCTLR	240
MEMDIMM	240
MEMORY	243
MESSAGE	244
MOVEIOA	244
MSG0001	245
MSG0002	245
MSG0003	245
MSG0005	245
NETSERV	245
NEXTLVL	245
NO_PNUM	245
NODECR	245
NODEPL	246
NOFRUS	247
NSCABLE	247
NTDEVDR	247
NTLANDD	247
NTOPSYS	247
NTUSER	247
NTVSCSI	247
OPT_CLN	248
OPTLCBL	248
OPTLDRV	248
OPUSER	248
OSLIC	248
OSTERM	248
PGDPART	249
PIOCARD	253
PLDUMP	256
PLUS	256
PPCIMIN	257
PPCISYS	257
PPCITWR	257
PRI_PCI	257
PRMIOA	258
PSI_LNK	258
PTFSRCH	258
PTNNTWK	258
PWRCBL	259
PWROC	259
PWRSPLY	259
PWRVPD	262
QDCCRLS	264
QSYSOPR	264
REFER	265

REM_NIC	265
REM_SYS	265
SASCABL	265
SASEXP	266
SI_CARD	267
SI_PHB	268
SIADPCD	268
SICNTRL	268
SIIOADP	269
SIRGCBL	274
SIRGCFG	274
SIRSTAT	275
SLOTERR	279
SLOTUSE	280
SNSDATA	281
SPBUS	281
SPNETWK	281
SPNLCRD	282
SRCTB1X	282
STORIOA	282
SVCDOS	283
SVCPROC	283
SYSBKP2	284
SYSBKPL	285
SYSBP	285
SYSNTWK	286
TAPCLN	286
TAPCNFG	286
TOD	286
TOD_BAT	286
TOPORT	287
TWRBKPL	290
TWRCARD	290
TWRPLNR	293
UC235	293
UC236	294
UG3LB	294
UG3AS	294
UJ0E2	294
UJ0E3	294
UJ0E6	294
UJ0E7	295
UJ0E9	295
UJ6P3	295
UJ9GC	295
UJA32	296
UJA33	296
UJA34	296
UJA35	297
UJA36	297
UJB35	297
UJB36	298
UJB37	298
UJC35	298
UJC36	299
UJC37	299
UJC38	300
UJE31	300
UJE32	300
UJE33	300
UJE34	300

UJE35	300
UJE36	301
UJE37	301
UJE38	301
UJE39	302
UJE40	302
UJJ35	302
UJJ36	302
UJJ37	303
UJJ38	303
UJJ39	303
UJP37	303
ULNZ3	304
ULNZ4	304
UNM31	304
UNM32	304
UNM35	305
UNM36	305
UNM38	305
UNP20	305
UNU01	305
UNU02	305
UNU31	306
UNU32	306
UPLF1.	306
UPLF2.	306
UPLF3.	307
UPLF4.	307
UPLF5.	307
UPLF6.	307
UPSUNIT	308
USER	308
UX201.	308
UX202.	308
UY1Z1	309
UY1Z2	309
UY1Z3	309
UY1Z4	309
UY1Z5	309
VPDPART	310
VRMOD	315

Appendix. Notices	317
Trademarks	318
Electronic emission notices	318
Class A Notices.	318
Terms and conditions.	322

Safety notices

Safety notices may be printed throughout this guide:

- **DANGER** notices call attention to a situation that is potentially lethal or extremely hazardous to people.
- **CAUTION** notices call attention to a situation that is potentially hazardous to people because of some existing condition.
- **Attention** notices call attention to the possibility of damage to a program, device, system, or data.

World Trade safety information

Several countries require the safety information contained in product publications to be presented in their national languages. If this requirement applies to your country, a safety information booklet is included in the publications package shipped with the product. The booklet contains the safety information in your national language with references to the U.S. English source. Before using a U.S. English publication to install, operate, or service this product, you must first become familiar with the related safety information in the booklet. You should also refer to the booklet any time you do not clearly understand any safety information in the U.S. English publications.

German safety information

Das Produkt ist nicht für den Einsatz an Bildschirmarbeitsplätzen im Sinne § 2 der Bildschirmarbeitsverordnung geeignet.

Laser safety information

IBM® servers can use I/O cards or features that are fiber-optic based and that utilize lasers or LEDs.

Laser compliance

All lasers are certified in the U.S. to conform to the requirements of DHHS 21 CFR Subchapter J for class 1 laser products. Outside the U.S., they are certified to be in compliance with IEC 60825 as a class 1 laser product. Consult the label on each part for laser certification numbers and approval information.

CAUTION:

This product might contain one or more of the following devices: CD-ROM drive, DVD-ROM drive, DVD-RAM drive, or laser module, which are Class 1 laser products. Note the following information:

- **Do not remove the covers. Removing the covers of the laser product could result in exposure to hazardous laser radiation. There are no serviceable parts inside the device.**
- **Use of the controls or adjustments or performance of procedures other than those specified herein might result in hazardous radiation exposure.**

(C026)

CAUTION:

Data processing environments can contain equipment transmitting on system links with laser modules that operate at greater than Class 1 power levels. For this reason, never look into the end of an optical fiber cable or open receptacle. (C027)

CAUTION:

This product contains a Class 1M laser. Do not view directly with optical instruments. (C028)

CAUTION:

Some laser products contain an embedded Class 3A or Class 3B laser diode. Note the following information: laser radiation when open. Do not stare into the beam, do not view directly with optical instruments, and avoid direct exposure to the beam. (C030)

Power and cabling information for NEBS (Network Equipment-Building System) GR-1089-CORE

The following comments apply to the IBM servers that have been designated as conforming to NEBS (Network Equipment-Building System) GR-1089-CORE:

The equipment is suitable for installation in the following:

- Network telecommunications facilities
- Locations where the NEC (National Electrical Code) applies

The intrabuilding ports of this equipment are suitable for connection to intrabuilding or unexposed wiring or cabling only. The intrabuilding ports of this equipment *must not* be metallically connected to the interfaces that connect to the OSP (outside plant) or its wiring. These interfaces are designed for use as intrabuilding interfaces only (Type 2 or Type 4 ports as described in GR-1089-CORE) and require isolation from the exposed OSP cabling. The addition of primary protectors is not sufficient protection to connect these interfaces metallically to OSP wiring.

Note: All Ethernet cables must be shielded and grounded at both ends.

The ac-powered system does not require the use of an external surge protection device (SPD).

The dc-powered system employs an isolated DC return (DC-I) design. The DC battery return terminal *shall not* be connected to the chassis or frame ground.

Failing function codes, failing items, and symbolic FRUs

Failing Function Codes (FFCs), Failing Items (FIs), and Symbolic Field Replaceable Units (FRUs) provide the information necessary to fix a problem identified by an System Reference Code (SRC) or Service Request Number (SRN).

PDF files for failing function codes, failing items, and symbolic FRUs

You can view and print a PDF of this information.

Failing function codes, failing items, and symbolic FRUs

Failing function codes, failing items, and symbolic FRUs provide details for the service provider about items that may need to be replaced.

Failing function codes, failing items, and symbolic FRUs  (approximately 2.5 MB)

Saving PDF files

Large PDF files can be difficult to open online. For best results, save the PDF to your local drive for viewing or printing. Follow these steps:

1. Right-click the PDF link in your browser.
2. Click the option that saves the PDF locally.
3. Navigate to the directory in which you want to save the PDF.
4. Click **Save**.

Downloading Adobe® Reader

You need Adobe Reader installed on your system to view or print these PDF files. You can download a free copy from the Adobe Reader Web site at <http://www.adobe.com/products/acrobat/readstep2.html>



Failing function codes

Failing function codes represent functions within the system unit.

The failing function codes are listed in numerical sequence.

Failing function code 11A

The cryptographic coprocessor adapter battery kit is the failing item.

Use the following table to determine the part number for the field replaceable unit (FRU):

CCIN or FFC	Type and model	Part number	Description	Location code
11A	8203-E4A, 8204-E8A, 9117-MMA, 9407-M15, 9408-M25, 9409-M50	09J8199	Cryptographic Coprocessor Adapter battery kit	U n-P1-C x

Failing function code 132

The program that just loaded might be damaged.

Failing function code 141

The 857 MB disk enclosure assembly is the failing item.

Use the following table to determine the part number for the field replaceable unit (FRU):

CCIN or FFC	Type and model	Part number	Description	Location code
141		4569502	857 MB Disk Enclosure Assembly	U n-P1...

Failing function code 151

The battery for the time-of-day clock, NVRAM, etc. is the failing item.

Use the following table to determine the part number for the field replaceable unit (FRU):

CCIN or FFC	Type and model	Part number	Description	Location code
151	8203-E4A, 9407-M15, 9408-M25	44V4359	Battery	U n-P1
151	8204-E8A, 9409-M50	16G8095	Battery	U n-P1
151	9117-MMA	16G8095	Battery	U n-P1-C11-E1

After replacement of this FRU, do the following:

1. Set the system date and time.
2. Set the network IP addresses (for machines that IPL from a network).
3. Set the bootlist to reflect the customers preference for the IPL devices (when it is different from the default list).

Failing function code 152

A system power supply is the problem.

Check the power supply LEDs to verify the location. Use the following table to determine the part number for the field replaceable unit (FRU):

CCIN or FFC	Type and model	Part number	Description	Location code
152	8203-E4A, 9407-M15, 9408-M25	44V4195	Power supply	Un-Ex
152	8204-E8A, 9409-M50	44V3559	Power supply (ac)	Un-Ex
152	8204-E8A, 9409-M50	42R6607	Power supply (dc)	Un-Ex
152	9117-MMA	39J2779	Power supply	Un-Ex
152	7311-D10	22R3958	Power supply	Un-Ex
152	7311-D11	22R3958	Power supply	Un-Ex
152	7311-D20	39J2781	Power supply	Un-Ex

Failing function code 153

A device drawer, expansion unit power supply is the failing item.

Use the following table to determine the part number for the field replaceable unit (FRU):

CCIN or FFC	Type and model	Part number	Description	Location code
153	5886	39R6547	Power supply	Un-Ex
153	5786, 5787, 7031-D24, 7031-T24	12R9078 (966 Watt) 15R7998 (845 Watt) Note: Use with a power supply having the same wattage.	Power supply	Un-Ex
153	7214-1U2	95P3651	Power supply	Un-Ex
153	7311-D10	22R3958	Power supply	Un-Ex
153	7311-D11	22R3958	Power supply	Un-Ex
153	7311-D20	39J2781	Power supply	Un-Ex
153	7314-G30	42R4491	Power supply	Un-Ex

Failing function code 159

The problem is with a tablet or a tablet puck.

Use the following table to determine the part number for the field replaceable unit (FRU):

CCIN or FFC	Type and model	Part number	Description	Location code
159	6093 Models 21, 22	6247455	Tablet cursor	Un-P1-Cx-Ty
159	6093 Models 11, 12	74F3131	Tablet cursor, 4-button	Un-P1-Cx-Ty
159	6093 Models 11, 12	74F3132	Tablet cursor, 6-button	Un-P1-Cx-Ty

Failing function code 165

The problem is with the control panel (operator panel).

Use the following table to determine the part number for the field replaceable unit (FRU):

CCIN or FFC	Type and model	Part number	Description	Location code
165	8203-E4A, 9407-M15, 9408-M25	10N9737	Control (operator) panel	Un-D1
165	8204-E8A, 9409-M50	42R5505	Control (operator) panel	Un-D1
165	9117-MMA	39J3272	Control (operator) panel	Un-D1

Failing function code 166

The problem is with a fan assembly.

Use the following table to determine the part number for the field replaceable unit (FRU):

CCIN or FFC	Type and model	Part number	Description	Location code
166	5886	39R6547	Fan (in power supply FRU)	Un-Ax

166	7214-1U2	95P3651	Fan (in power supply FRU)	Un-Ax
166	7031-D24, 7031-T24	39J0859	Fan assembly	Un-Ax
166	7311-D11, 7311-G30	32N1256	Fan assembly	Un-Ax
166	7311-D20	39J1176	Fan assembly	Un-Ax
166	8203-E4A, 9407-M15, 9408-M25	39J4517	Fan assembly	Un-Ax
166	8204-E4A	44V3454	Fan assembly	Un-Ax

Failing function code 167

The problem is with a power supply fan.

Replace the power supply. Use the following table to determine the part number for the field replaceable unit (FRU):

CCIN or FFC	Type and model	Part number	Description	Location code
167	8203-E4A, 9407-M15, 9408-M25	44V4195	Power supply (ac)	Un-E1
167	8204-E8A, 9409-M50	44V3559	Power supply (ac)	Un-E1
167	8204-E8A, 9409-M50	42R6607	Power supply (dc)	Un-E1
167	9117-MMA	39J2779	Power supply	Un-E1

Failing function code 169

The problem is an operator panel logic problem.

Use the following table to determine the part number for the field replaceable unit (FRU):

CCIN or FFC	Type and model	Part number	Description	Location code
165	8203-E4A, 9407-M15, 9408-M25	10N9737	Control (operator) panel	Un-D1
165	8204-E8A, 9409-M50	42R5505	Control (operator) panel	Un-D1
169	9117-MMA	39J3272	Control (operator) panel	Un-D1

Failing function code 185

The problem is with an X.25 interface co-processor adapter.

Use the following table to determine the part number for the field replaceable unit (FRU):

CCIN or FFC	Type and model	Part number	Description	Location code
185	Any	71G6458	X.25 Interface Co-Processor Adapter	Un-P1-Cx

Failing function code 186

The problem is with the co-processor multiport adapter.

Use the following table to determine the part number for the field replaceable unit (FRU):

CCIN or FFC	Type and model	Part number	Description	Location code
186	Any	33F8967	Co-Processor Multiport Adapter Model 2	Un-P1-Cx
186	Any	84F7540	Co-Processor Multiport Adapter Model 2 daughter card	Un-P1-Cx
186	Any	53F2662	Co-Processor Multiport Adapter Model 2 1 MB memory module	Un-P1-Cx

Failing function code 188

The problem is with a tablet stylus.

Use the following table to determine the part number for the field replaceable unit (FRU):

CCIN or FFC	Type and model	Part number	Description	Location code
188	6093 Models 11, 12	74F3133	Tablet stylus	N/A
188	6093 Models 21, 22	6247454	Tablet stylus	N/A

Failing function code 190

The problem is with an internal disk signal cable.

Use the following table to determine the part number for the field replaceable unit (FRU):

CCIN or FFC	Type and model	Part number	Description	Location code
190		21P7063	Internal disk signal cable	Un-P1-Cx-Ty

Failing function code 192

The problem is with a portable disk drive power supply.

Use the following table to determine the part number for the field replaceable unit (FRU):

CCIN or FFC	Type and model	Part number	Description	Location code
192	7203	00G2960	portable disk drive power supply	N/A

Failing function code 199

The problem is with an internal disk unit backplane.

Use the following table to determine the part number for the field replaceable unit (FRU):

CCIN or FFC	Type and model	Part number	Description	Location code
-------------	----------------	-------------	-------------	---------------

199	8203-E4A, 9407-M15, 9408-M25	07P6910	Disk unit backplane	Un-P2
199	8203-E4A, 9407-M15, 9408-M25	44V4270	Disk unit backplane (with SAS expander)	Un-P2
199	8204-E8A, 9409-M50	10N9532	Disk unit backplane	Un-P2
199	8204-E8A, 9409-M50	10N9664	Disk unit backplane (with SAS expander)	Un-P2
199	9117-MMA	03N4801	Disk unit backplane	Un-P3

Failing function code 201

The problem is with an internal disk signal cable.

Use the following table to determine the part number for the field replaceable unit (FRU):

CCIN or FFC	Type and model	Part number	Description	Location code
201		21P7063	Internal disk signal cable (associated with FFC 190)	Un-P1-Cx-Ty

Failing function code 203

A system power supply is the problem.

Check the power supply LEDs to verify the location. Use the following table to determine the part number for the field replaceable unit (FRU):

CCIN or FFC	Type and model	Part number	Description	Location code
167	8203-E4A, 9407-M15, 9408-M25	44V4195	Power supply	Un-Ex
167	8204-E8A, 9409-M50	44V3559	Power supply (ac)	Un-Ex
167	8204-E8A, 9409-M50	42R6607	Power supply (dc)	Un-Ex
203	9117-MMA	39J2779	Power supply	Un-Ex

Failing function code 210

The problem is with a processor card or system processor backplane.

Use the following table to determine the part number for the field replaceable unit (FRU):

CCIN or FFC	Type and model	Part number	Description	Location code
210	8203-E4A, 9407-M15, 9408-M25	42R7898	System backplane	Un-P1
210	8204-E8A, 9409-M50	10N9377	GHz 4.2 GHz POWER6™, 2 Core Processor Card	Un-P1-Cx
210	8204-E8A, 9409-M50	10N9380	GHz 4.7 GHz POWER6, 2 Core Processor Card	Un-P1-Cx
210	9117-MMA	10N9146	GHz 3.5 GHz POWER6, 2 Core Processor Card	Un-P2-Cx

210	9117-MMA	10N9144	GHz 4.2 GHz POWER6, 2 Core Processor Card	Un-P2-Cx
210	9117-MMA	10N9139	GHz 4.7 GHz POWER6, 2 Core Processor Card	Un-P2-Cx
210	9117-MMA	03N6902	System processor backplane	Un-P2

Failing function code 212

The problem is in the cache of a processor card.

Use the following table to determine the part number for the field replaceable unit (FRU):

CCIN or FFC	Type and model	Part number	Description	Location code
212	8203-E4A, 9407-M15, 9408-M25	42R7898	System backplane	Un-P1
212	8204-E8A, 9409-M50	10N9377	GHz 4.2 GHz POWER6, 2 Core Processor Card	Un-P1-Cx
212	8204-E8A, 9409-M50	10N9380	GHz 4.7 GHz POWER6, 2 Core Processor Card	Un-P1-Cx
212	9117-MMA	10N9146	GHz 3.5 GHz POWER6, 2 Core Processor Card	Un-P2-Cx
212	9117-MMA	10N9144	GHz 4.2 GHz POWER6, 2 Core Processor Card	Un-P2-Cx
212	9117-MMA	10N9139	GHz 4.7 GHz POWER6, 2 Core Processor Card	Un-P2-Cx
212	9117-MMA	03N6902	System processor backplane	Un-P2

Failing function code 214

The problem is with a memory control unit (processor card or system backplane).

Use the following table to determine the part number for the field replaceable unit (FRU):

CCIN or FFC	Type and model	Part number	Description	Location code
214	8203-E4A, 9407-M15, 9408-M25	42R7898	System backplane	Un-P1
214	8204-E8A, 9409-M50	10N9377	GHz 4.2 GHz POWER6, 2 Core Processor Card	Un-P1-Cx
214	8204-E8A, 9409-M50	10N9380	GHz 4.7 GHz POWER6, 2 Core Processor Card	Un-P1-Cx

214	9117-MMA	10N9146	GHz 3.5 GHz POWER6, 2 Core Processor Card	Un-P2-Cx
214	9117-MMA	10N9144	GHz 4.2 GHz POWER6, 2 Core Processor Card	Un-P2-Cx
214	9117-MMA	10N9139	GHz 4.7 GHz POWER6, 2 Core Processor Card	Un-P2-Cx
214	9117-MMA	03N6902	System processor backplane	Un-P2

Failing function code 217

The problem is with a memory control unit (processor card or system processor backplane).

Use the following table to determine the part number for the field replaceable unit (FRU):

CCIN or FFC	Type and model	Part number	Description	Location code
217	8203-E4A, 9407-M15, 9408-M25	42R7898	System backplane	Un-P1
217	8204-E8A, 9409-M50	10N9377	GHz 4.2 GHz POWER6, 2 Core Processor Card	Un-P1-Cx
217	8204-E8A, 9409-M50	10N9380	GHz 4.7 GHz POWER6, 2 Core Processor Card	Un-P1-Cx
217	9117-MMA	10N9146	GHz 3.5 GHz POWER6, 2 Core Processor Card	Un-P2-Cx
217	9117-MMA	10N9144	GHz 4.2 GHz POWER6, 2 Core Processor Card	Un-P2-Cx
217	9117-MMA	10N9139	GHz 4.7 GHz POWER6, 2 Core Processor Card	Un-P2-Cx
217	9117-MMA	03N6902	System processor backplane	Un-P2

Failing function code 219

The problem is a common memory logic problem.

Note: If more than a pair of memory modules from the same memory card are reported missing, replace the FRU that the memory modules plug into first. Otherwise, replace the memory module at the physical location code that is reported.

Use the following table to determine the part number for the field replaceable unit (FRU):

CCIN or FFC	Type and model	Part number	Description	Location code
219	9117-MMA	15R7433	512 MG DIMM, DDR2	Un-P2-Cx-Cy
219	9117-MMA	15R7436	1 GB DIMM, DDR2	Un-P2-Cx-Cy

219	9117-MMA	15R7439	2 GB DIMM, DDR2	Un-P2-Cx-Cy
219	9117-MMA	15R7445	4 GB DIMM, DDR2	Un-P2-Cx-Cy
219	9117-MMA	15R7448	8 GB DIMM, DDR2	Un-P2-Cx-Cy

Failing function code 221

The problem is a system I/O control logic problem.

Use the following table to determine the part number for the field replaceable unit (FRU):

CCIN or FFC	Type and model	Part number	Description	Location code
221	8203-E4A, 9407-M15, 9408-M25	42R7898	System backplane	Un-P1
221	8204-E8A, 9409-M50	10N9369	System backplane	Un-P1
221	9117-MMA	42R7352	I/O backplane	Un-P1
221	9117-MMA	03N6902	System processor backplane	Un-P2

Failing function code 226

The problem is a system status logic problem.

Use the following table to determine the part number for the field replaceable unit (FRU):

CCIN or FFC	Type and model	Part number	Description	Location code
226	8203-E4A, 9407-M15, 9408-M25	42R7898	System backplane	Un-P1
226	8204-E8A, 9409-M50	10N9369	System backplane	Un-P1
226	9117-MMA	42R7352	I/O backplane	Un-P1
226	9117-MMA	03N6902	System processor backplane	Un-P2

Failing function code 227

The problem is a system status logic problem.

Use the following table to determine the part number for the field replaceable unit (FRU):

CCIN or FFC	Type and model	Part number	Description	Location code
227	8203-E4A, 9407-M15, 9408-M25	42R7898	System backplane	Un-P1
227	8204-E8A, 9409-M50	10N9369	System backplane	Un-P1
227	9117-MMA	42R7352	I/O backplane	Un-P1
227	9117-MMA	03N6902	System processor backplane	Un-P2

Failing function code 240

The problem is a Token-ring network problem.

Use the following table to determine the part number for the field replaceable unit (FRU):

CCIN or FFC	Type and model	Part number	Description	Location code
240	Any		Token-ring network problem	

Failing function code 241

The problem is an ethernet network problem.

Use the following table to determine the part number for the field replaceable unit (FRU):

CCIN or FFC	Type and model	Part number	Description	Location code
241	Any		Ethernet network problem	

Failing function code 2502

A backplane might be failing.

Use the following table to determine the part number for the field replaceable unit (FRU):

CCIN or FFC	Type and model	Part number	Description	Location code
2502	8203-E4A, 9407-M15, 9408-M25	42R7898	I/O backplane, integrated 3GB SAS controller	Un-P1
2502	8204-E8A, 9409-M50	10N9369	System backplane, integrated 3GB SAS controller	Un-P1
2502	9117-MMA	42R7352	I/O backplane, integrated 3GB SAS controller	Un-P1

Failing function code 2503

A SAS RAID enablement card might be failing.

Use the following table to determine the part number for the field replaceable unit (FRU):

CCIN or FFC	Type and model	Part number	Description	Location code
2503	8203-E4A, 9407-M15, 9408-M25	44V3298	SAS RAID Enablement Card	Un-P1-C10
2503	8204-E8A, 9409-M50	44V3298	SAS RAID Enablement Card	Un-P1-C11
2503	9117-MMA	42R8319	SAS RAID Enablement Card	Un-P1-C12

Failing function code 2504

A SAS RAID auxiliary cache card might be failing.

Use the following table to determine the part number for the field replaceable unit (FRU):

CCIN or FFC	Type and model	Part number	Description	Location code
2504	8203-E4A, 9407-M15, 9408-M25	44V3298	SAS RAID auxiliary cache card	Un-P1-C9
2504	8204-E8A, 9409-M50	44V3298	SAS RAID auxiliary cache card	Un-P1-C10

Failing function code 2505

A SAS RAID adapter might be failing.

Use the following table to determine the part number for the field replaceable unit (FRU):

CCIN or FFC	Type and model	Part number	Description	Location code
2505	8203-E4A, 9407-M15, 9408-M25	44V3298	PCI-XDDR Planar 3Gb SAS RAID adapter	Un-P1-C10
2505	8204-E8A, 9409-M50	44V3298	PCI-XDDR Planar 3Gb SAS RAID adapter	Un-P1-C11

Failing function code 251

The problem is in the cables for a parallel printer.

Use the following table to determine the part number for the field replaceable unit (FRU):

CCIN or FFC	Type and model	Part number	Description	Location code
251	Any	8529214	Cable, parallel printer	Un-P1-Cx-Ty
251	Any	8185219	Cable, parallel printer	Un-P1-Cx-Ty

Failing function code 2512

A SCSI RAID adapter might be failing.

Use the following table to determine the part number for the field replaceable unit (FRU):

CCIN or FFC	Type and model	Part number	Description	Location code
2512	Any	97P6130	PCI-X DDR quad channel ultra320 SCSI RAID adapter	

Failing function code 2513

A SCSI RAID adapter might be failing.

Use the following table to determine the part number for the field replaceable unit (FRU):

CCIN or FFC	Type and model	Part number	Description	Location code
-------------	----------------	-------------	-------------	---------------

2513	Any	42R6578	PCI-X DDR quad channel ultra320 SCSI RAID adapter, the FRU is an assembly of two parts, replace the assembly. The same FRU is used for FFC 252E.	Un-P1-Cx
------	-----	---------	--	----------

Failing function code 2514

A SCSI RAID adapter might be failing.

Use the following table to determine the part number for the field replaceable unit (FRU):

CCIN or FFC	Type and model	Part number	Description	Location code
2514	Any	39J2012	PCI-X DDR dual channel ultra320 SCSI RAID adapter	Un-P1-Cx

Failing function code 2515

A SAS adapter might be failing.

Use the following table to determine the part number for the field replaceable unit (FRU):

CCIN or FFC	Type and model	Part number	Description	Location code
2515	Any	44V3296	PCI-X DDR External Dual - x4 Port SAS Adapter	Un-P1-Cx

Failing function code 2516

Configuring PCI-E JBOD SAS Adapter.

Failing function code 2517

Configuring PCI-X RAID SAS adapter.

Failing function code 2518

Configuring PCI-E RAID SAS adapter.

Failing function code 252

The problem is in the standard 9-pin to 25-pin converter cable.

Use the following table to determine the part number for the field replaceable unit (FRU):

CCIN or FFC	Type and model	Part number	Description	Location code
252	Any	23R4632	Standard 9-pin to 25-pin converter cable	Un-P1-Cx-Ty

Failing function code 2520

The SCSI adapter might be failing.

Use the following table to determine the part number for the field replaceable unit (FRU):

CCIN or FFC	Type and model	Part number	Description	Location code
2520	Any	09P2544	Dual-channel ultra3 SCSI PCI adapter	

Failing function code 2521

The processor subsystem chassis might be failing.

Use the following table to determine the part number for the field replaceable unit (FRU):

CCIN or FFC	Type and model	Part number	Description	Location code
2521	9117-MMA	44P3988	Processor subsystem chassis (with backplane and DASD ribbon cable)	

Failing function code 2522

The SCSI adapter might be failing.

Use the following table to determine the part number for the field replaceable unit (FRU):

CCIN or FFC	Type and model	Part number	Description	Location code
2522	Any	97P6513	PCI-X dual channel U320 SCSI adapter Note: Use the location code to identify the failing FRU. Determine if the failing FRU is integrated on the system board. If the failing FRU is integrated use FFC 221. If the failing FRU is not integrated replace the FRU identified here.	

Failing function code 2523

The SCSI RAID adapter or enablement card might be failing.

The following table to determine the part number for the field replaceable unit (FRU):

CCIN or FFC	Type and model	Part number	Description	Location code
-------------	----------------	-------------	-------------	---------------

	Any	97P3960	<p>PCI-X dual channel U320 SCSI RAID adapter or enablement card.</p> <p>Notes:</p> <ol style="list-style-type: none"> 1. Use the location code to identify if the failing FRU is a RAID enablement card plugged into a special slot on the I/O planar or if it is a PCI-X adapter. 2. If the failing FRU is a PCI-X adapter, replace the FRU identified here. If the failing FRU is a RAID enablement card use FFC 2525. 3. If the problem persists after replacing the RAID enablement card, use FFC 2522 to replace the integrated SCSI adapter. 	
--	-----	---------	--	--

Failing function code 2524

The SCSI adapter might be failing.

Use the following table to determine the part number for the field replaceable unit (FRU):

CCIN or FFC	Type and model	Part number	Description	Location code
-------------	----------------	-------------	-------------	---------------

2524	Any	97P6513	<p>Missing options resolution for integrated PCI-X dual channel U320 SCSI adapter.</p> <p>Note: Use the location code to identify the failing FRU. Determine if the failing FRU is integrated on the system board. If the failing FRU is integrated on the system backplane, replace the system backplane.</p> <p>If the failing FRU is not integrated, replace the PCI-X dual channel U320 SCSI adapter (FRU # 97P6513)</p>	
------	-----	---------	---	--

Failing function code 2525

The SCSI RAID enablement card might be failing.

Use the following table to determine the part number for the field replaceable unit (FRU):

CCIN or FFC	Type and model	Part number	Description	Location code
2525	Any	80P2868	Missing options resolution for integrated PCI-X dual channel U320 SCSI RAID enablement card.	

Failing function code 2526

The SCSI RAID battery pack might be failing.

Use the following table to determine the part number for the field replaceable unit (FRU):

CCIN or FFC	Type and model	Part number	Description	Location code
2526	Any	44L0313	PCI-X ultra320 SCSI RAID Battery Pack	

Failing function code 2527

The SCSI RAID adapter might be failing.

Use the following table to determine the part number for the field replaceable unit (FRU):

CCIN or FFC	Type and model	Part number	Description	Location code
-------------	----------------	-------------	-------------	---------------

2527	Any	42R6249	Quad channel ultra320 SCSI RAID adapter	
------	-----	---------	---	--

Failing function code 2528

The SCSI adapter might be failing.

>

Use the following table to determine the part number for the field replaceable unit (FRU):

CCIN or FFC	Type and model	Part number	Description	Location code
2528	Any	42R4860	PCI-X dual channel ultra320 SCSI adapter	

Failing function code 2529

The SCSI RAID adapter might be failing.

Use the following table to determine the part number for the field replaceable unit (FRU):

CCIN or FFC	Type and model	Part number	Description	Location code
2529	Any	39J5652	PCI-X dual channel ultra320 SCSI RAID adapter	
2529	Any	39J5653	PCI-X dual channel ultra320 SCSI RAID adapter	

Failing function code 252B

The SCSI adapter might be failing.

Use the following table to determine the part number for the field replaceable unit (FRU):

CCIN or FFC	Type and model	Part number	Description	Location code
252B	Any	39M3417	PCI-X DDR dual channel ultra320 SCSI adapter (2 way)	
252B	Any	39M3419	PCI-X DDR dual channel ultra320 SCSI adapter (4 way)	

Failing function code 252D

The SCSI adapter might be failing.

Use the following table to determine the part number for the field replaceable unit (FRU):

CCIN or FFC	Type and model	Part number	Description	Location code
252D	Any	42R4860	PCI-X DDR dual channel ultra320 SCSI adapter	Un-P1-Cx

Failing function code 252E

The SCSI RAID adapter might be failing.

Use the following table to determine the part number for the field replaceable unit (FRU):

CCIN or FFC	Type and model	Part number	Description	Location code
252E	Any	42R6578	PCI-X DDR quad channel ultra320 SCSI RAID adapter, the FRU is an assembly of two parts, replace the assembly. The same FRU is used for FFC 2513.	Un-P1-Cx

Failing function code 253

The multiprotocol cable might be failing.

Use the following table to determine the part number for the field replaceable unit (FRU):

CCIN or FFC	Type and model	Part number	Description	Location code
253	Any		The problem is in the multiprotocol cable, EIA-422A, which is customer-provided.	Un-P1-Cx-Ty

Failing function code 2530

The ethernet adapter might be failing.

Use the following table to determine the part number for the field replaceable unit (FRU):

CCIN or FFC	Type and model	Part number	Description	Location code
2530	Any	09P3196	10/100 Mbps Ethernet PCI adapter II	

Failing function code 2531

The ethernet adapter might be failing.

Use the following table to determine the part number for the field replaceable unit (FRU):

CCIN or FFC	Type and model	Part number	Description	Location code
2531	Any	03N6971	10 Gigabit-LR Ethernet PCI-X adapter	

Failing function code 2532

The ethernet adapter might be failing.

Use the following table to determine the part number for the field replaceable unit (FRU):

CCIN or FFC	Type and model	Part number	Description	Location code
2532	Any	03N6969	10 Gigabit-SR Ethernet PCI-X adapter	

Failing function code 2533

The ethernet adapter might be failing.

Use the following table to determine the part number for the field replaceable unit (FRU):

CCIN or FFC	Type and model	Part number	Description	Location code
2533	Any	10N8264	10 Gigabit-SR Ethernet PCI-X 2.0 DDR adapter	

Failing function code 2534

The ethernet adapter might be failing.

Use the following table to determine the part number for the field replaceable unit (FRU):

CCIN or FFC	Type and model	Part number	Description	Location code
2534	Any	10N8263	10 Gigabit-LR Ethernet PCI-X 2.0 DDR adapter	

Failing function code 2535

The ethernet adapter might be failing.

Use the following table to determine the part number for the field replaceable unit (FRU):

CCIN or FFC	Type and model	Part number	Description	Location code
2535	Any	03N5444	4-port 10/100/1000 base-TX Ethernet PCI-X adapter	

Failing function code 2537

The ethernet adapter might be failing.

Use the following table to determine the part number for the field replaceable unit (FRU):

CCIN or FFC	Type and model	Part number	Description	Location code
2537	Any	03N6973* or 80P6451**	Dual port gigabit Ethernet-SX PCI-X Adapter	Un-Px-Cx

* Designed to comply with RoHS requirement.

** Not designed to comply with the RoHS requirement.

Failing function code 2538

The ethernet adapter might be failing.

Use the following table to determine the part number for the field replaceable unit (FRU):

CCIN or FFC	Type and model	Part number	Description	Location code
2538	Any	03N5297* or 00P6131**	2-Port 10/100/1000 Base-TX Ethernet PCI-X Adapter (FC 5706)	U n-P x-C x
2538	Any	03N5298* or 80P6450**	2-Port 10/100/1000 Base-TX Ethernet PCI-X Adapter (FC 1983)	U n-P x-C x
2538	Any	03N5531* or 03N4701**	2-Port 10/100/1000 Base-TX Ethernet PCI-X Adapter (FC 1990)	U n-P x-C x

* Designed to comply with RoHS requirement.

** Not designed to comply with the RoHS requirement.

Failing function code 254

The problem is in the 4-port multiprotocol EIA-232, V.24 cable.

Use the following table to determine the part number for the field replaceable unit (FRU):

CCIN or FFC	Type and model	Part number	Description	Location code
254	Any	71F0165	4-port multiprotocol EIA-232, V.24 cable	U n-P1-C x-T y

Failing function code 254E

The fibre channel expansion card might be failing.

Use the following table to determine the part number for the field replaceable unit (FRU):

CCIN or FFC	Type and model	Part number	Description	Location code
254E	Any	13N2056	Fibre Channel expansion card	

Failing function code 2550

The graphics adapter might be failing.

Use the following table to determine the part number for the field replaceable unit (FRU):

CCIN or FFC	Type and model	Part number	Description	Location code
2550	Any	80P7124	POWER® GXT4500P graphics adapter	

Failing function code 2551

The graphics adapter might be failing.

Use the following table to determine the part number for the field replaceable unit (FRU):

CCIN or FFC	Type and model	Part number	Description	Location code
2551	Any	09P3391	POWER GXT6500P graphics adapter	

Failing function code 2555

Configuring 73 GB SAS interface 3.5" form factor drives.

Failing function code 2556

Configuring 146 GB SAS interface 3.5" form factor drives.

Failing function code 2557

Configuring 300 GB SAS interface 3.5" form factor drives.

Failing function code 256

The problem is in the 10 ft. (3.04 m) token-ring cable.

Use the following table to determine the part number for the field replaceable unit (FRU):

CCIN or FFC	Type and model	Part number	Description	Location code
256	Any	6339098	10 ft. (3.04 m) Token-ring cable	Un-P1-Cx-Ty

Failing function code 2562

The keyboard/mouse USB PCI attachment card might be failing.

Use the following table to determine the part number for the field replaceable unit (FRU):

CCIN or FFC	Type and model	Part number	Description	Location code
2562	Any	09P2470	Keyboard/mouse USB PCI attachment card	

Failing function code 2564

The keyboard/mouse USB PCI attachment card might be failing.

Use the following table to determine the part number for the field replaceable unit (FRU):

CCIN or FFC	Type and model	Part number	Description	Location code
2564	Any	80P2994	Keyboard/mouse USB PCI attachment card	

Failing function code 2566

The diskette drive might be failing.

Use the following table to determine the part number for the field replaceable unit (FRU):

CCIN or FFC	Type and model	Part number	Description	Location code
2566	Any	03N4962	USB 3.5 inch micro diskette drive	

Failing function code 2568

The CD-ROM might be failing.

Use the following table to determine the part number for the field replaceable unit (FRU):

CCIN or FFC	Type and model	Part number	Description	Location code
2568	Any		Generic USB CD-ROM	

Failing function code 256D

The fibre channel adapter might be failing.

Use the following table to determine the part number for the field replaceable unit (FRU):

CCIN or FFC	Type and model	Part number	Description	Location code
256D	Any	26R0893 26R0889	4Gb fibre channel adapter	

Failing function code 256E

The 4-port 10/100/1000 Base-TX PCI Express adapter might be failing.

If you replace a 4-port 10/100/1000 Base-TX PCI Express adapter and the problem is not resolved, replace the I/O backplane.

Note: Use the location code to identify the failing unit or enclosure.

Use the following table to determine the part number for the field replaceable unit (FRU):

CCIN or FFC	Type and model	Part number	Description	Location code
256E	Any	10N8556	4-port 10/100/1000 Base-TX PCI Express Adapter	Un-Px
256E	8203-E4A, 9407-M15, 9408-M25	42R7898	System backplane	Un-P1
256E	8204-E8A, 9409-M50	10N9369	System backplane	Un-P1
256E	9117-MMA	42R7352	I/O backplane	Un-P1

Failing function code 257

The problem is in the 4-port multiprotocol, V.35 cable.

Use the following table to determine the part number for the field replaceable unit (FRU):

CCIN or FFC	Type and model	Part number	Description	Location code
257	Any	71F0162	4-port multiprotocol, V.35 cable	Un-P1-Cx-Ty

Failing function code 2570

The cryptographic accelerator PCI adapter might be failing.

Use the following table to determine the part number for the field replaceable unit (FRU):

CCIN or FFC	Type and model	Part number	Description	Location code
2570	Any	11P1856	IBM cryptographic accelerator PCI adapter	

Failing function code 2571

The 2-port PCI asynchronous EIA-232 adapter might be failing.

Use the following table to determine the part number for the field replaceable unit (FRU):

CCIN or FFC	Type and model	Part number	Description	Location code
2571	Any	80P4353	2-Port PCI Asynchronous EIA-232 Adapter	

Failing function code 2572

The xCrypto coprocessor card might be failing.

Use the following table to determine the part number for the field replaceable unit (FRU):

CCIN or FFC	Type and model	Part number	Description	Location code
2572	Any	41U0442 12R6540	PCI xCrypto coprocessor card	
11A		41V1061	Battery kit	

Failing function code 258

The problem is in the 4-port multiprotocol cable.

Use the following table to determine the part number for the field replaceable unit (FRU):

CCIN or FFC	Type and model	Part number	Description	Location code
258	Any	40F9897	4-port multiprotocol cable	Un-P1-Cx-Ty

Failing function code 2580

The SCSI accessed fault-tolerant enclosure (SAF-TE) device might be failing.

Use the following table to determine the part number for the field replaceable unit (FRU):

CCIN or FFC	Type and model	Part number	Description	Location code
2580	Any	21P7165	SCSI accessed fault-tolerant enclosure (SAF-TE) device	

Failing function code 2581

The 1 GB iSCSI TOE PCI-X adapter might be failing.

Use the following table to determine the part number for the field replaceable unit (FRU):

CCIN or FFC	Type and model	Part number	Description	Location code
2581	Any	03N6056	1 GB iSCSI TOE PCI-X adapter (copper connector).	

Failing function code 2583

The 1 GB iSCSI TOE PCI-X adapter might be failing.

Use the following table to determine the part number for the field replaceable unit (FRU):

CCIN or FFC	Type and model	Part number	Description	Location code
2583	Any	26K6490	1 GB iSCSI TOE PCI-X adapter (JS daughter card) (copper connector)	

Failing function code 2586

The failing function code indicates a failure in the Host Ethernet Adapter (HEA) which is a part of the passthrough card.

The HEA controller is integrated on the I/O backplane in the system unit. If you replace a passthrough card and the problem is not resolved, replace the I/O backplane.

Note: Use the location code to identify the failing unit or enclosure.

Use the following table to determine the part number for the field replaceable unit (FRU):

CCIN or FFC	Type and model	Part number	Description	Location code
2586	9117-MMA	42R6775	Passthru card, 1 GB ethernet. This card also provides connection for the system VPD card, system ports, and SPCN cable.	Un-P1-C10

2586	9117-MMA	42R7000	Passthru card, 1 GB ethernet quad. This card also provides connection for the system VPD card, system ports, and SPCN cable.	Un-P1-C10
2586	9117-MMA	42R7358	Passthru card, 10 GB ethernet long. This card also provides connection for the system VPD card, system ports, and SPCN cable.	Un-P1-C10
2586	9117-MMA	42R7352	I/O backplane	Un-P1

Failing function code 2587

The DVD-ROM drive might be failing.

Use the following table to determine the part number for the field replaceable unit (FRU):

CCIN or FFC	Type and model	Part number	Description	Location code
2587	Any	39J5774	Slimline DVD-ROM Drive	Un-P4-Dx

Failing function code 2588

The DVD-RAM drive might be failing.

Use the following table to determine the part number for the field replaceable unit (FRU):

CCIN or FFC	Type and model	Part number	Description	Location code
2588	Any	39J5772	IBM 4.7 GB Slimline DVD-RAM Drive	Un-P4-Dx

Failing function code 259

The problem is in the async EIA-232D, V.24 cable.

Use the following table to determine the part number for the field replaceable unit (FRU):

CCIN or FFC	Type and model	Part number	Description	Location code
259	Any	42R5206	Async EIA-232D, V.24 cable	Un-P1-Cx-Ty

Failing function code 2590

The 48x IDE CD-ROM drive black bezel might be failing.

Use the following table to determine the part number for the field replaceable unit (FRU):

CCIN or FFC	Type and model	Part number	Description	Location code
-------------	----------------	-------------	-------------	---------------

2590	Any	24P3605	48x IDE CD-ROM drive black bezel	
------	-----	---------	----------------------------------	--

Failing function code 2591

The IDE 16/48X DVD-ROM black bezel might be failing.

Use the following table to determine the part number for the field replaceable unit (FRU):

CCIN or FFC	Type and model	Part number	Description	Location code
2591	Any	53P2735	IDE 16/48X DVD-ROM black bezel	

Failing function code 2592

The IDE 8X/24X DVD-ROM might be failing.

Use the following table to determine the part number for the field replaceable unit (FRU):

CCIN or FFC	Type and model	Part number	Description	Location code
2592	Any	39J3522	Slimline IDE 8X/24X DVD-ROM	

Failing function code 2593

The IDE DVD-RAM drive might be failing.

Use the following table to determine the part number for the field replaceable unit (FRU):

CCIN or FFC	Type and model	Part number	Description	Location code
2593	Any	39J1364	IDE DVD-RAM drive	

Failing function code 25A0

A backplane might be failing.

Use the following table to determine the part number for the field replaceable unit (FRU):

CCIN or FFC	Type and model	Part number	Description	Location code
25A0	8203-E4A, 9407-M15, 9408-M25	42R7898	System backplane	Un-P1
25A0	8204-MMA	10N9369	System backplane	Un-P1
25A0	9117-MMA	03N6902	System processor backplane	Un-P2

Failing function code 25B9

The 1 GB PCI-X iSCSI TOE ethernet adapter might be failing.

Use the following table to determine the part number for the field replaceable unit (FRU):

CCIN or FFC	Type and model	Part number	Description	Location code
-------------	----------------	-------------	-------------	---------------

25B9	Any	03N6058	1 GB PCI-X iSCSI TOE Ethernet adapter (fiber)	
------	-----	---------	---	--

Failing function code 25C0

The Gigabit-SX ethernet PCI-X adapter might be failing.

Use the following table to determine the part number for the field replaceable unit (FRU):

CCIN or FFC	Type and model	Part number	Description	Location code
	Any	00P3055	IBM Gigabit-SX Ethernet PCI-X adapter	

Failing function code 25C1

The 10/100/1000 base-TX PCI-X adapter might be failing.

Use the following table to determine the part number for the field replaceable unit (FRU):

CCIN or FFC	Type and model	Part number	Description	Location code
Any	9117-MMA	00P3056	IBM 10/100/1000 base-TX PCI-X adapter	

Failing function code 25C2

The dual-port Gigabit SX ethernet PCI-X adapter might be failing.

Use the following table to determine the part number for the field replaceable unit (FRU):

CCIN or FFC	Type and model	Part number	Description	Location code
25C2	Any	00P4290	IBM dual-port Gigabit SX Ethernet PCI-X adapter	

Failing function code 25C3

The 10/100/1000 base-TX dual-port PCI-X adapter might be failing.

Use the following table to determine the part number for the field replaceable unit (FRU):

CCIN or FFC	Type and model	Part number	Description	Location code
25C3	Any	00P4289	IBM 10/100/1000 base-TX dual-port PCI-X adapter	

Failing function code 25C4

The Broadcom dual-port Gbps ethernet PCI-X adapter might be failing.

Use the following table to determine the part number for the field replaceable unit (FRU):

CCIN or FFC	Type and model	Part number	Description	Location code
25C4	Any	13N0504	Broadcom dual-port Gbps Ethernet PCI-X adapter	
25C4	Any	73P9031	Broadcom dual-port Gbps Ethernet PCI-X daughter card	

Failing function code 25D0

The audio adapter might be failing.

Use the following table to determine the part number for the field replaceable unit (FRU):

CCIN or FFC	Type and model	Part number	Description	Location code
25D0	Any	00P4648	PCI audio adapter	

Failing function code 25D2

Configuring JS21 SAS expansion adapter.

Failing function code 25F8

The 1 GB PCI-X iSCSI TOE ethernet adapter might be failing.

Use the following table to determine the part number for the field replaceable unit (FRU):

CCIN or FFC	Type and model	Part number	Description	Location code
25F8	Any	80P4092	1 GB PCI-X iSCSI TOE Ethernet adapter (copper)	

Failing function code 260

The problem is in the 4-port multiprotocol, X.21 cable.

Use the following table to determine the part number for the field replaceable unit (FRU):

CCIN or FFC	Type and model	Part number	Description	Location code
260	Any	71F0164	4-port multiprotocol, X.21 cable	Un-P1-Cx-Ty

Failing function code 2600

The fibre channel adapter might be failing.

Use the following table to determine the part number for the field replaceable unit (FRU):

CCIN or FFC	Type and model	Part number	Description	Location code
2600	Any	80P6416	PCI 64-Bit Fibre Channel adapter	

Failing function code 2601

The fibre channel adapter might be failing.

Use the following table to determine the part number for the field replaceable unit (FRU):

CCIN or FFC	Type and model	Part number	Description	Location code
2601	Any	03N7069	PCI 64-Bit Fibre Channel adapter	

Failing function code 2602

The fibre channel adapter might be failing.

Use the following table to determine the part number for the field replaceable unit (FRU):

CCIN or FFC	Type and model	Part number	Description	Location code
2602	Any	03N5012	PCI 64-Bit 4 GB fibre channel adapter (Low Profile 1-Port)	
2602	Any	03N5029	PCI 64-Bit 4 GB fibre channel adapter (2-Port)	
2602	Any	03N5027	PCI 64-Bit 4 GB fibre channel adapter (Low Profile 2-Port)	

Failing function code 2603

Configuring 1- and 2-port 4Gb PCI-E fibre channel adapters.

Failing function code 2604

Configuring fibre channel daughter card.

Failing function code 261

The problem is in the RS/232 interposer.

Use the following table to determine the part number for the field replaceable unit (FRU):

CCIN or FFC	Type and model	Part number	Description	Location code
261	Any	10N7453	RS/232 interposer	Un-P1-Tx

Failing function code 2611

The 36/72 GB Data72 4-mm internal tape drive might be failing.

Use the following table to determine the part number for the field replaceable unit (FRU):

CCIN or FFC	Type and model	Part number	Description	Location code
2611	Any	95P1989	36/72 GB Data72 4-mm Internal Tape Drive	U n-P x-D x

Failing function code 2612

The 80/160 GB internal tape drive might be failing.

Use the following table to determine the part number for the field replaceable unit (FRU):

CCIN or FFC	Type and model	Part number	Description	Location code
2612	Any	19P4898	80/160 GB Internal Tape Drive with VXA Technology	Un-Px-Dx

Failing function code 2613

The 200/400 GB half high Ultrium 2 tape drive might be failing.

Use the following table to determine the part number for the field replaceable unit (FRU):

CCIN or FFC	Type and model	Part number	Description	Location code
2613	Any	96P1775	200/400 GB Half High Ultrium 2 tape drive	U n-P x-D x

Failing function code 2614

The 160/320 GB internal tape drive VXA-320 might be failing.

Use the following table to determine the part number for the field replaceable unit (FRU):

CCIN or FFC	Type and model	Part number	Description	Location code
2614	Ant	95P1976	160/320 GB internal tape drive VXA-320	Un-Px-Dx

Failing function code 2615

The DAT 160 80GB tape drive might be failing.

Use the following table to determine the part number for the field replaceable unit (FRU):

CCIN or FFC	Type and model	Part number	Description	Location code
2615	Any	23R9723	DAT 160 80GB Tape Drive	Un-D1

Failing function code 2616

The 36/72 GB 4mm internal tape drive might be failing.

Use the following table to determine the part number for the field replaceable unit (FRU):

CCIN or FFC	Type and model	Part number	Description	Location code
2616	Any	23R2619	36/72 GB 4mm Internal Tape Drive	Un-Dx

Failing function code 2617

The LTO3 400 GB tape drive might be failing.

Use the following table to determine the part number for the field replaceable unit (FRU):

CCIN or FFC	Type and model	Part number	Description	Location code
2617	Any	23R7038	LTO3 400 GB Tape Drive	Un-D1

Failing function code 2618

The 800 GB/1.6 TB Ultrium 4 SAS tape drive might be failing.

Use the following table to determine the part number for the field replaceable unit (FRU):

CCIN or FFC	Type and model	Part number	Description	Location code
2618	Any	45E1127	800 GB/1.6 TB Ultrium 4 SAS tape drive	Un-Dx

Failing function code 262

The problem is in the 8-port multiport interface cable.

Use the following table to determine the part number for the field replaceable unit (FRU):

CCIN or FFC	Type and model	Part number	Description	Location code
262	Any	00F5524	8-port multiport interface cable	Un-P1-Cx-Tx

Failing function code 263

The problem is in the EIA-232 terminal cable.

Use the following table to determine the part number for the field replaceable unit (FRU):

CCIN or FFC	Type and model	Part number	Description	Location code
263	Any	10N6535	EIA-232 Terminal cable	Un-P1-Cx-Ty

Failing function code 2631

The integrated IDE controller might be failing.

Use the following table to determine the part number for the field replaceable unit (FRU):

CCIN or FFC	Type and model	Part number	Description	Location code
2631	Any		Integrated IDE controller	

Failing function code 2640

The 2.5 inch IDE disk drive might be failing.

Use the following table to determine the part number for the field replaceable unit (FRU):

CCIN or FFC	Type and model	Part number	Description	Location code
-------------	----------------	-------------	-------------	---------------

2640	Any	See system unit parts information	2.5 inch IDE disk drive	
------	-----	-----------------------------------	-------------------------	--

Failing function code 2641

The 73.4 GB U3 10K RPM 68-pin bolt in SCSI disk drive might be failing.

Use the following table to determine the part number for the field replaceable unit (FRU):

CCIN or FFC	Type and model	Part number	Description	Location code
2641	Any	03N5255	73.4 GB U3 10K rpm 68 pin bolt in SCSI disk drive	Un-Px-Dx

Failing function code 2642

The 73.4 GB U3 10K rpm 80-pin SCSI disk drive might be failing.

Use the following table to determine the part number for the field replaceable unit (FRU):

CCIN or FFC	Type and model	Part number	Description	Location code
2642	Any	03N5260 or 03N6325	73.4 GB U3 10K rpm 80 pin SCSI disk drive	Un-Px-Dx

Failing function code 2643

The 73.4 GB U3 10K RPM 80-pin SCSI disk drive might be failing.

Use the following table to determine the part number for the field replaceable unit (FRU):

CCIN or FFC	Type and model	Part number	Description	Location code
2643	Any	03N6327 or 03N5262	73.4 GB U3 10K rpm 80 pin SCSI disk drive	Un-Px-Dx

Failing function code 2644

The 146.8 GB 10,000 RPM 80-pin SCSI bolt in disk drive might be failing.

Use the following table to determine the part number for the field replaceable unit (FRU):

CCIN or FFC	Type and model	Part number	Description	Location code
2644	Any	03N5256	146.8 GB 10,000 RPM 80 pin SCSI bolt in disk drive	Un-Px-Dx

Failing function code 2645

The 146.8 GB 10,000 RPM Ultra320 80-pin SCSI disk drive might be failing.

Use the following table to determine the part number for the field replaceable unit (FRU):

CCIN or FFC	Type and model	Part number	Description	Location code
-------------	----------------	-------------	-------------	---------------

2645	Any	03N5265 or 03N6330	146.8 GB 10,000 RPM Ultra320 80 pin SCSI disk drive	Un-Px-Dx
------	-----	--------------------	---	----------

Failing function code 2646

The 146.8 GB 10,000 RPM Ultra320 80-pin SCSI disk drive might be failing.

Use the following table to determine the part number for the field replaceable unit (FRU):

CCIN or FFC	Type and model	Part number	Description	Location code
2646		03N6332 or 03N5267	146.8 GB 10,000 RPM Ultra320 80 pin SCSI disk drive	Un-Px-Dx

Failing function code 2647

The 300GB 10K RPM Ultra320 bolt in SCSI disk drive might be failing.

Use the following table to determine the part number for the field replaceable unit (FRU):

CCIN or FFC	Type and model	Part number	Description	Location code
2647	Any	03N5257	300GB 10K RPM Ultra320 bolt in SCSI disk drive, 1 inch	Un-Px-Dx

Failing function code 2648

The 300GB 10K RPM Ultra320 bolt in SCSI disk drive might be failing.

Use the following table to determine the part number for the field replaceable unit (FRU):

CCIN or FFC	Type and model	Part number	Description	Location code
2648	Any	03N5270 or 03N6335	300GB 10K RPM Ultra320 bolt in SCSI disk drive, 1 inch	Un-Px-Dx

Failing function code 2649

The 300GB 10K RPM Ultra320 SCSI disk drive might be failing.

Use the following table to determine the part number for the field replaceable unit (FRU):

CCIN or FFC	Type and model	Part number	Description	Location code
2649		03N5272 or 03N6337	300GB 10K RPM Ultra320 SCSI disk drive	Un-Px-Dx

Failing function code 264B

The 36.4 GB 15K RPM Ultra3 80-pin SCSI disk drive/carrier might be failing.

Use the following table to determine the part number for the field replaceable unit (FRU):

CCIN or FFC	Type and model	Part number	Description	Location code
264B	Any	03N5275 or 03N6340	36.4 GB 15K RPM Ultra3 80 pin SCSI disk drive/carrier	Un-Px-Dx

Failing function code 264D

The 36.4 GB U3 15K RPM 80-pin SCSI disk drive might be failing.

Use the following table to determine the part number for the field replaceable unit (FRU):

CCIN or FFC	Type and model	Part number	Description	Location code
264D	Any	03N5277 or 03N6342	36.4 GB U3 15K rpm 80 pin SCSI disk drive	Un-Px-Dx

Failing function code 264E

The 73.4 GB U320 15K RPM 80-pin SCSI disk drive might be failing.

Use the following table to determine the part number for the field replaceable unit (FRU):

CCIN or FFC	Type and model	Part number	Description	Location code
264E	Any	03N5280 or 03N6345	73.4 GB U320 15K rpm 80 pin SCSI disk drive	Un-Px-Dx

Failing function code 2650

Configuring iSCSI devices.

Failing function code 2651

Configuring SVC.

Failing function code 2653

The 73.4 GB U3 15K RPM 80-pin SCSI disk drive might be failing.

Use the following table to determine the part number for the field replaceable unit (FRU):

CCIN or FFC	Type and model	Part number	Description	Location code
2653	Any	03N6347 or 03N5282	73.4 GB U3 15K rpm 80 pin SCSI disk drive	Un-Px-Dx

Failing function code 2654

The 146.8 GB U320 15K RPM 80-pin SCSI disk drive might be failing.

Use the following table to determine the part number for the field replaceable unit (FRU):

CCIN or FFC	Type and model	Part number	Description	Location code
-------------	----------------	-------------	-------------	---------------

2654	Any	03N5285 or 03N6350	146.8 GB U320 15K rpm 80 pin SCSI disk drive	Un-Px-Dx
------	-----	--------------------	--	----------

Failing function code 2655

The 146.8 GB 15K RPM 80-pin U320 SCSI disk drive might be failing.

Use the following table to determine the part number for the field replaceable unit (FRU):

CCIN or FFC	Type and model	Part number	Description	Location code
2655	Any	03N5288 or 03N6352	146.8 GB 15K RPM 80 pin U320 SCSI disk drive	Un-Px-Dx

Failing function code 2658

The 73.4 GB 10K RPM 80-pin SCSI disk drive might be failing.

Use the following table to determine the part number for the field replaceable unit (FRU):

CCIN or FFC	Type and model	Part number	Description	Location code
2658	Any	03N5762	73.4 GB 10K rpm 80 pin SCSI disk drive	Un-Px-Dx

Failing function code 2659

The 146.8 GB 10K RPM 80-pin SCSI disk drive might be failing.

Use the following table to determine the part number for the field replaceable unit (FRU):

CCIN or FFC	Type and model	Part number	Description	Location code
2659	Any	03N5763	146.8 GB 10K rpm 80 pin SCSI disk drive	Un-Px-Dx

Failing function code 265B

The 300GB 10K RPM Ultra320 SCSI disk drive might be failing.

Use the following table to determine the part number for the field replaceable unit (FRU):

CCIN or FFC	Type and model	Part number	Description	Location code
265B	Any	03N5764	300GB 10K RPM Ultra320 SCSI disk drive, 1 inch	Un-Px-Dx

Failing function code 266

The problem is in the RJ-45 to DB-25 converter cable.

Use the following table to determine the part number for the field replaceable unit (FRU):

CCIN or FFC	Type and model	Part number	Description	Location code
-------------	----------------	-------------	-------------	---------------

266	Any	59F3432	RJ-45 to DB-25 converter cable	Un-P1-Cx-Ty
-----	-----	---------	--------------------------------	-------------

Failing function code 2667

The problem is with a SAS enclosure services manager or with a system backplane.

Use the following table to determine the part number for the field replaceable unit (FRU):

CCIN or FFC	Type and model	Part number	Description	Location code
2667	7214-1U2	95P4036	Electronics tray, also known as the enclosure services manager	Un-P1
2667	5886	44V3937	Enclosure services manager	Un-C1, Un-C2
2667	8203-E4A, 9407-M15, 9408-M25	42R7898	System backplane	Un-P1, Un-C2
2667	8204-E8A, 9409-M50	10N9369	System backplane	Un-P1, Un-C2
2667	9117-MMA	42R7352	I/O backplane	Un-P1, Un-C2

Failing function code 267

The problem is in the 4-port multiprotocol jumper cable assembly.

Use the following table to determine the part number for the field replaceable unit (FRU):

CCIN or FFC	Type and model	Part number	Description	Location code
267	Any	81F8570	4-port multiprotocol jumper cable assembly	Un-P1-Cx-Ty

Failing function code 2680

The problem is with a generic SAS adapter.

Use the following table to determine the part number for the field replaceable unit (FRU):

CCIN or FFC	Type and model	Part number	Description	Location code
2680	Any		Generic SAS adapter	Un-Px-Cx

Failing function code 2681

The media bay insert might be failing.

Use the following table to determine the part number for the field replaceable unit (FRU):

CCIN or FFC	Type and model	Part number	Description	Location code
2681	7214-1U2	95P4044	DVD tray assembly	Un-Px

Failing function code 271

The problem is an X.25 attachment cable.

Use the following table to determine the part number for the field replaceable unit (FRU):

CCIN or FFC	Type and model	Part number	Description	Location code
271	Any	07F3151	Cable, X.25 attachment cable, X.21 (3 m)	Un-P1-Cx-Ty
271	Any	53F3926	Cable, X.25 attachment cable, X.21 (6 m)	Un-P1-Cx-Ty

Failing function code 272

The problem is an X.25 attachment cable, V.24.

Use the following table to determine the part number for the field replaceable unit (FRU):

CCIN or FFC	Type and model	Part number	Description	Location code
272	Any	07F3160	Cable, X.25 attachment cable, V.24 (3 m)	Un-P1-Cx-Ty
272	Any	53F3927	Cable, X.25 attachment cable, V.24 (6 m)	Un-P1-Cx-Ty

Failing function code 273

The problem is an X.25 attachment cable, V.35.

Use the following table to determine the part number for the field replaceable unit (FRU):

CCIN or FFC	Type and model	Part number	Description	Location code
273	Any	07F3171	Cable, X.25 attachment cable, V.35 (3 m)	Un-P1-Cx-Ty
273	Any	53F3928	Cable, X.25 attachment cable, V.35 (6 m)	Un-P1-Cx-Ty

Failing function code 276

The problem is in the SCSI controller cable.

Use the following table to determine the part number for the field replaceable unit (FRU):

CCIN or FFC	Type and model	Part number	Description	Location code
276	Any	31F4221	SCSI controller cable	Un-P1-Tx (x equals 12, 13, or 14)

Failing function code 277

The problem is in the internal SCSI controller cable.

See SCSI service hints in the service guide for the unit on which you are working.

Failing function code 279

The PTC resistor has been tripped.

Note: This problem is related to a SCSI single-ended adapter. See SCSI service hints in the service guide that is for the unit on which you are working.

Failing function code 282

The problem is in the system backplane.

Use the following table to determine the part number for the field replaceable unit (FRU):

CCIN or FFC	Type and model	Part number	Description	Location code
282	8203-E4A, 9407-M15, 9408-M25	42R7898	System backplane	Un-P1
282	8204-E8A, 9409-M50	10N9369	System backplane	Un-P1
282	9117-MMA	03N6902	System processor backplane	Un-P1

Failing function code 287

The problem is in an I/O drawer power supply.

Use the following table to determine the part number for the field replaceable unit (FRU):

CCIN or FFC	Type and model	Part number	Description	Location code
287	7311-D10	22R3958	Power supply	Un-P1
287	7311-D11	22R3958	Power supply	Un-P1
287	7311-D20	39J2781	Power supply	Un-P1

Failing function code 289

The problem is an I/O drawer power supply problem.

Use the following table to determine the part number for the field replaceable unit (FRU):

CCIN or FFC	Type and model	Part number	Description	Location code
289	7311-D10	22R3958	Power supply	Un-P1
289	7311-D11	22R3958	Power supply	Un-P1
289	7311-D20	39J2781	Power supply	Un-P1

Failing function code 292

The problem is a Host - PCI bridge problem.

Use the following table to determine the part number for the field replaceable unit (FRU):

CCIN or FFC	Type and model	Part number	Description	Location code
292	8203-E4A, 9407-M15, 9408-M25	42R7898	System backplane	Un-P1
292	8204-E8A, 9409-M50	10N9369	System backplane	Un-P1
292	9117-MMA	42R7352	I/O backplane	Un-P1

292	7311-D10	80P2339	I/O backplane	Un-P1
292	7311-D11	23R0181	I/O backplane	Un-P1
292	7311-D20	39J0515	I/O backplane	Un-P1

Failing function code 293

The problem is a PCI - PCI bridge problem.

Use the following table to determine the part number for the field replaceable unit (FRU):

CCIN or FFC	Type and model	Part number	Description	Location code
293	8203-E4A, 9407-M15, 9408-M25	42R7898	System backplane	Un-P1
293	8204-E8A, 9409-M50	10N9369	System backplane	Un-P1
293	9117-MMA	42R7352	I/O backplane	Un-P1
293	9117-MMA	03N6902	System backplane	Un-P2

Failing function code 294

The problem is an MPIC Interrupt Controller problem.

Use the following table to determine the part number for the field replaceable unit (FRU):

CCIN or FFC	Type and model	Part number	Description	Location code
294	8203-E4A, 9407-M15, 9408-M25	42R7898	System backplane	Un-P1
294	8204-E8A, 9409-M50	10N9369	System backplane	Un-P1
294	9117-MMA	42R7352	I/O backplane	Un-P1
294	9117-MMA	03N6902	System backplane	Un-P2

Failing function code 295

The problem is a PCI - ISA bridge problem.

Use the following table to determine the part number for the field replaceable unit (FRU):

CCIN or FFC	Type and model	Part number	Description	Location code
295	8203-E4A, 9407-M15, 9408-M25	42R7898	System backplane	Un-P1
295	8204-E8A, 9409-M50	10N9369	System backplane	Un-P1
295	9117-MMA	42R7352	I/O backplane	Un-P1
295	9117-MMA	03N6902	System backplane	Un-P2

Failing function code 296

The problem is a PCI device or adapter problem.

Use the following table to determine the part number for the field replaceable unit (FRU):

CCIN or FFC	Type and model	Part number	Description	Location code
-------------	----------------	-------------	-------------	---------------

296	Any		The FRU can only be identified by it's location code reported by the diagnostic programs. See the Display Diagnostic Log summary for more information regarding the service request number.	Un-P1-Cx
-----	-----	--	---	----------

Failing function code 297

Texture memory module for the GXT800P graphics adapter.

Use the following table to determine the part number for the field replaceable unit (FRU):

CCIN or FFC	Type and model	Part number	Description	Location code
297	Any	93H6055	Texture memory module for the GXT800P Graphics Adapter	Un-P1-Cx-Cy

Failing function code 298

The problem is in the base memory module for the GXT800P graphics adapter.

Use the following table to determine the part number for the field replaceable unit (FRU):

CCIN or FFC	Type and model	Part number	Description	Location code
	Any	93H6057	Base memory module for the GXT800P graphics adapter	Un-P1-Cx-Cy

Failing function code 2C3

The problem is in a 2-port multiprotocol adapter cable.

Use the following table to determine the part number for the field replaceable unit (FRU):

CCIN or FFC	Type and model	Part number	Description	Location code
2C3	Any	93H5263	2-Port Multiprotocol adapter cable V.24	Un-P1-Cx-Tx
2C3	Any	93H5264	2-Port Multiprotocol adapter cable V.35	Un-P1-Cx-Tx
2C3	Any	93H5265	2-Port Multiprotocol adapter cable V.36	Un-P1-Cx-Tx
2C3	Any	93H5267	2-Port Multiprotocol adapter cable X.21	Un-P1-Cx-Tx

Failing function code 2C4

The problem is a system bus connector problem.

Use the following table to determine the part number for the field replaceable unit (FRU):

CCIN or FFC	Type and model	Part number	Description	Location code
2C4	8203-E4A, 9407-M15, 9408-M25	42R7898	System backplane	Un-P1
2C4	8204-E8A, 9409-M50	10N9369	System backplane	Un-P1
2C4	9117-MMA	03N6902	System processor backplane	Un-P2

Failing function code 2C5

The problem is in system memory.

Use the following table to determine the part number for the field replaceable unit (FRU):

CCIN or FFC	Type and model	Part number	Description	Location code
2C5	9117-MMA	15R7433	512 MG DIMM, DDR2	Un-P2-Cx-Cy
2C5	9117-MMA	15R7436	1 GB DIMM, DDR2	Un-P2-Cx-Cy
2C5	9117-MMA	15R7439	2 GB DIMM, DDR2	Un-P2-Cx-Cy
2C5	9117-MMA	15R7445	4 GB DIMM, DDR2	Un-P2-Cx-Cy
2C5	9117-MMA	15R7448	8 GB DIMM, DDR2	Un-P2-Cx-Cy

Failing function code 2C6

The problem is in system memory.

Use the following table to determine the part number for the field replaceable unit (FRU):

CCIN or FFC	Type and model	Part number	Description	Location code
2C6	9117-MMA	15R7433	512 MG DIMM, DDR2	Un-P2-Cx-Cy
2C6	9117-MMA	15R7436	1 GB DIMM, DDR2	Un-P2-Cx-Cy
2C6	9117-MMA	15R7439	2 GB DIMM, DDR2	Un-P2-Cx-Cy
2C6	9117-MMA	15R7445	4 GB DIMM, DDR2	Un-P2-Cx-Cy
2C6	9117-MMA	15R7448	8 GB DIMM, DDR2	Un-P2-Cx-Cy

Failing function code 2C7

The problem is in system memory.

Use the following table to determine the part number for the field replaceable unit (FRU):

CCIN or FFC	Type and model	Part number	Description	Location code
2C7	9117-MMA	15R7433	512 MG DIMM, DDR2	Un-P2-Cx-Cy
2C7	9117-MMA	15R7436	1 GB DIMM, DDR2	Un-P2-Cx-Cy
2C7	9117-MMA	15R7439	2 GB DIMM, DDR2	Un-P2-Cx-Cy
2C7	9117-MMA	15R7445	4 GB DIMM, DDR2	Un-P2-Cx-Cy
2C7	9117-MMA	15R7448	8 GB DIMM, DDR2	Un-P2-Cx-Cy

Failing function code 2C8

The problem is in the I/O bus (internal signal or power cables, system backplane, or I/O backplane).

Use the following table to determine the part number for the field replaceable unit (FRU):

CCIN or FFC	Type and model	Part number	Description	Location code
2C8	9117-MMA	42R7352	I/O backplane	Un-P1
2C8	8203-E4A, 9407-M15, 9408-M25	42R7898	System backplane	Un-P1
2C8	8204-E8A, 9409-M50	10N9369	System backplane	Un-P1
2C8	7311-D10	80P2339	I/O (drawer) backplane	Un-P1
2C8	7311-D11	23R0181	I/O (drawer) backplane	Un-P1
2C8	7311-D20	39J0515	I/O (drawer) backplane	Un-P1

Failing function code 2C9

The problem is in the PCI bus on the I/O backplane.

Replace the I/O backplane. Use the following table to determine the part number for the field replaceable unit (FRU):

CCIN or FFC	Type and model	Part number	Description	Location code
2C9	8203-E4A, 9407-M15, 9408-M25	42R7898	System backplane	Un-P1
2C9	8204-E8A, 9409-M50	10N9369	System backplane	Un-P1
2C9	9117-MMA	42R7352	I/O backplane	Un-P1

Failing function code 2CC

The problem is in system memory.

Use the following table to determine the part number for the field replaceable unit (FRU):

CCIN or FFC	Type and model	Part number	Description	Location code
2CC	9117-MMA	15R7433	512 MG DIMM, DDR2	Un-P2-Cx-Cy
2CC	9117-MMA	15R7436	1 GB DIMM, DDR2	Un-P2-Cx-Cy
2CC	9117-MMA	15R7439	2 GB DIMM, DDR2	Un-P2-Cx-Cy
2CC	9117-MMA	15R7445	4 GB DIMM, DDR2	Un-P2-Cx-Cy
2CC	9117-MMA	15R7448	8 GB DIMM, DDR2	Un-P2-Cx-Cy

Failing function code 2CD

The problem is in system memory.

Use the following table to determine the part number for the field replaceable unit (FRU):

CCIN or FFC	Type and model	Part number	Description	Location code
2CD	9117-MMA	15R7433	512 MG DIMM, DDR2	Un-P2-Cx-Cy
2CD	9117-MMA	15R7436	1 GB DIMM, DDR2	Un-P2-Cx-Cy
2CD	9117-MMA	15R7439	2 GB DIMM, DDR2	Un-P2-Cx-Cy
2CD	9117-MMA	15R7445	4 GB DIMM, DDR2	Un-P2-Cx-Cy
2CD	9117-MMA	15R7448	8 GB DIMM, DDR2	Un-P2-Cx-Cy

Failing function code 2CE

The problem is in system memory.

Use the following table to determine the part number for the field replaceable unit (FRU):

CCIN or FFC	Type and model	Part number	Description	Location code
2CE	9117-MMA	15R7433	512 MG DIMM, DDR2	Un-P2-Cx-Cy
2CE	9117-MMA	15R7436	1 GB DIMM, DDR2	Un-P2-Cx-Cy
2CE	9117-MMA	15R7439	2 GB DIMM, DDR2	Un-P2-Cx-Cy
2CE	9117-MMA	15R7445	4 GB DIMM, DDR2	Un-P2-Cx-Cy
2CE	9117-MMA	15R7448	8 GB DIMM, DDR2	Un-P2-Cx-Cy

Failing function code 2D0

The problem is an ISA bus or an integrated device on the system backplane or I/O backplane.

Replace the system backplane or I/O backplane. Use the following table to determine the part number for the field replaceable unit (FRU):

CCIN or FFC	Type and model	Part number	Description	Location code
2D0	8203-E4A, 9407-M15, 9408-M25	42R7898	System backplane	Un-P1
2D0	8204-E8A, 9409-M50	10N9369	System backplane	Un-P1
2D0	9117-MMA	03N6902	System processor backplane	Un-P2
2D0	9117-MMA	42R7352	I/O backplane	Un-P1

Failing function code 2D00

The disk drive backplane might be failing.

Use the following table to determine the part number for the field replaceable unit (FRU):

CCIN or FFC	Type and model	Part number	Description	Location code
2D00	9117-MMA	09P5895	Cable, DASD 50 pins, disk drive backplane	
2D00	9117-MMA	00P2983	Disk drive backplane	

Failing function code 2D01

The SCSI RAID battery pack might be failing.

Use the following table to determine the part number for the field replaceable unit (FRU):

CCIN or FFC	Type and model	Part number	Description	Location code
2D01	Any	39J5554	PCI-X quad channel U320 SCSI RAID battery pack, attached to the PCI-X quad channel U320 SCSI RAID adapter	Un-P1-Cx

Failing function code 2D02

The adapter might be failing.

Use the following table to determine the part number for the field replaceable unit (FRU):

CCIN or FFC	Type and model	Part number	Description	Location code
2D02	Any		Generic USB Reference to Controller/Adapter	

Failing function code 2D03

Reserved.

Failing function code 2D05

The battery pack for the internal SAS RAID enablement card might be failing.

Use the following table to determine the part number for the field replaceable unit (FRU):

CCIN or FFC	Type and model	Part number	Description	Location code
2D05	Any	42R4635	Battery pack for the internal SAS RAID Enablement Card	

Failing function code 2D07

The PCI-X DDR auxiliary cache adapter might be failing.

Use the following table to determine the part number for the field replaceable unit (FRU):

CCIN or FFC	Type and model	Part number	Description	Location code
2D07	Any	42R5133	PCI-X DDR Auxiliary Cache Adapter	Un-P1-Cx

Failing function code 2D0B

The SAS RAID adapter might be failing.

Use the following table to determine the part number for the field replaceable unit (FRU):

CCIN or FFC	Type and model	Part number	Description	Location code
2D0B	Any	44V4813	PCI Express x8 Ext Dual-x4 3Gb SAS RAID Adapter	

Failing function code 2D1

The problem is an ISA bus or an integrated device on the system backplane or I/O backplane.

Replace the system backplane or I/O backplane. Use the following table to determine the part number for the field replaceable unit (FRU):

CCIN or FFC	Type and model	Part number	Description	Location code
2D1	8203-E4A, 9407-M15, 9408-M25	42R7898	System backplane	Un-P1
2D1	8204-E8A, 9409-M50	10N9369	System backplane	Un-P1
2D1	9117-MMA	03N6902	System processor backplane	Un-P2
2D1	9117-MMA	42R7352	I/O backplane	Un-P1

Failing function code 2D2

The problem is in a mezzanine bus arbiter.

Replace the I/O backplane. Use the following table to determine the FRU part number.

CCIN	Description	Model, expansion unit, or unit type	Part number
2D2	System backplane Un-P1	8203-E4A, 9407-M15, 9408-M25	42R7898
2D2	System backplane Un-P1	8204-E8A, 9409-M50	10N9369
2D2	I/O backplane	9117-MMA	42R7352
2D2	I/O drawer backplane	7311-D10	80P2339
2D2	I/O drawer backplane	7311-D11	23R0181
2D2	I/O drawer backplane	7311-D20	39J0515

Failing function code 2D3

The problem is in the service processor card.

The FRU part number is 10N8752.

Failing function code 2D4

The problem is a System/SP interface logic problem (I/O planar, system board).

For the FRU part number, see the service guide for the unit on which you are working.

Failing function code 2D5

The problem is a service processor to primary I/O bus problem.

Replace the I/O backplane. The FRU part number is 42R7352.

Failing function code 2D6

The problem is a service processor card.

Replace the service processor card. The FRU part number is 10N8752.

Failing function code 2D7

The problem is in the operator panel.

The FRU part number is 39J3272.

Failing function code 2D9

The problem is in the power controller.

Replace the I/O backplane. The FRU part number is 42R7352.

Failing function code 2E0

The problem is in the fan sensor.

Replace the I/O backplane. The FRU part number is 42R7352.

Failing function code 2E01

The 10 Gigabit ethernet-SR PCI Express adapter might be failing.

Use the following table to determine the part number for the field replaceable unit (FRU):

CCIN or FFC	Type and model	Part number	Description	Location code
2E01	Any	10N9033	10 Gigabit Ethernet-SR PCI Express Adapter	Un-Px-Dx

Failing function code 2E02

The 10 Gigabit ethernet-LR PCI Express adapter might be failing.

Use the following table to determine the part number for the field replaceable unit (FRU):

CCIN or FFC	Type and model	Part number	Description	Location code
2E02	Any	10N9034	10 Gigabit Ethernet-LR PCI Express Adapter	Un-Px-Dx

Failing function code 2E03

The 10 Gigabit RDMA ethernet adapter might be failing.

Use the following table to determine the part number for the field replaceable unit (FRU):

CCIN or FFC	Type and model	Part number	Description	Location code
2E03	Any	10N9505	10 Gb/s RDMA Ethernet Adapter	Un-Px-Dx

Failing function code 2E1

The problem is a thermal sensor.

Replace the operator (control) panel. The FRU part number is 39J3272.

Failing function code 2E2

The problem is a voltage sensor problem.

Replace the system backplane. The FRU part number is 03N6902.

Failing function code 2E3

The problem is in the serial port controller.

Replace the service processor card. The FRU part number is 10N8752.

Failing function code 2E4

The problem is in the JTAG/COP controller.

Replace the service processor. The FRU part number is 10N8752.

Failing function code 2E6

The problem is in a PCI differential Ultra SCSI controller.

The controller might be integrated on a backplane or on a PCI adapter. For the failing FRU part number, see the following table.

CCIN	Description	Model, expansion unit, or unit type	Part number
2E6	System backplane Un-P1	8203-E4A, 9407-M15, 9408-M25	42R7898
2E6	System backplane	8204-E8A, 9409-M50	10N9369
2E6	I/O backplane	9117-MMA	42R7352
2E6	SCSI PCI adapter	9117-MMA	See Managing PCI adapters for FRU part numbers
2E6	I/O drawer backplane	7311-D11	80P6626
2E6	I/O drawer backplane	7311-D20	See Finding parts, locations, and addresses.

Failing function code 2E7

The problem is a generic PCI SCSI adapter.

To determine the FRU part number, check the system unit or expansion unit for SCSI PCI adapters.

Failing function code 2E8

The problem is in a processor card.

To determine the FRU part number, check the system unit for installed processor cards.

Failing function code 2E12

The fibre channel adapter might be failing.

Use the following table to determine the part number for the field replaceable unit (FRU):

CCIN or FFC	Type and model	Part number	Description	Location code
2E12	Any	46C7006	8 Gb fibre channel adapter	

Failing function code 301

The problem is in system memory.

Go to the service guide for the system on which you are working.

Failing function code 302

The problem is in system memory.

Use the following table to determine the part number for the field replaceable unit (FRU):

CCIN or FFC	Type and model	Part number	Description	Location code
2CD	9117-MMA	15R7433	512 MG DIMM, DDR2	Un-P2-Cx-Cy
2CD	9117-MMA	15R7436	1 GB DIMM, DDR2	Un-P2-Cx-Cy
2CD	9117-MMA	15R7439	2 GB DIMM, DDR2	Un-P2-Cx-Cy
2CD	9117-MMA	15R7445	4 GB DIMM, DDR2	Un-P2-Cx-Cy
2CD	9117-MMA	15R7448	8 GB DIMM, DDR2	Un-P2-Cx-Cy

Failing function code 303

The problem is in system memory.

Go to the service guide for the system on which you are working.

Failing function code 304

The problem is in system memory.

Go to the service guide for the system on which you are working.

Failing function code 305

The problem is in system memory.

To determine the FRU part number, go to the service guide for the system on which you are working.

Failing function code 306

The problem is a Remote I/O (RIO) cable.

To determine the FRU part number, go to the service guide for the system on which you are working.

Failing function code 307

The problem is an expansion unit logic problem (I/O backplane).

See the following table for the FRU part number:

CCIN	Description	Model, expansion unit, or unit type	Part number
307	I/O backplane	9117-MMA	42R7352
307	I/O backplane	7311-D11	80P6626
307	I/O backplane	7311-D20	39J0515
307	I/O backplane	7314-G30	See Finding parts, locations, and addresses.

Failing function code 308

The problem is an I/O bridge problem.

See the following table for the FRU part number:

CCIN	Description	Model, expansion unit, or unit type	Part number
308	System backplane	8203-E4A, 9407-M15, 9408-M25	42R7898
308	System backplane	8204-E8A, 9409-M50	10N9369
	I/O backplane System processor backplane	9117-MMA	42R7352 03N6902

Failing function code 30A

The problem is in system memory.

To determine the FRU part number, go to the service guide for the system on which you are working.

Failing function code 30B

The problem is in system memory.

To determine the FRU part number, go to the service guide for the system on which you are working.

Failing function code 440

The problem is a 9.1 GB Ultra SCSI disk drive (no carrier).

See the following table for the FRU part number:

CCIN	Description	Model, expansion unit, or unit type	Part number
------	-------------	-------------------------------------	-------------

	9.1 GB ultra SCSI disk drive (no carrier)	Any	25L3101
--	---	-----	---------

Failing function code 441

The problem is a 18.2 GB Ultra SCSI disk drive (no carrier).

See the following table for the FRU part number:

CCIN	Description	Model, expansion unit, or unit type	Part number
	18.2 GB ultra SCSI disk drive (no carrier)	Any	25L3100

Failing function code 442

The problem is a 9.1 GB Ultra LVD SCSI disk drive.

See the following table for the FRU part number:

CCIN	Description	Model, expansion unit, or unit type	Part number
	9.1 GB ultra LVD SCSI disk drive	Any	09L3117

Failing function code 443

The problem is an 18.2 GB Ultra LVD SCSI disk drive.

See the following table for the FRU part number:

CCIN	Description	Model, expansion unit, or unit type	Part number
	18.2 GB ultra LVD SCSI disk drive	Any	09L3118

Failing function code 444

The problem is a 2-port multiprotocol PCI adapter (ASIC).

The FRU part number is 00P5920.

Failing function code 445

The problem is a 146.8 GB 15K RPM 80-pin U320 SCSI bolt in disk drive.

The FRU part number is 80P3911.

Failing function code 446

The problem is a 300 GB 10K RPM 58-pin U320 SCSI bolt in disk drive.

The FRU part number is 80P3157.

Failing function code 447

The problem is a PCI 64-bit fibre channel adapter.

The FRU part number is 80P4384.

Failing function code 451

The problem is a 73.4 GB 15K RPM Ultra3 SCSI disk drive/carrier.

The FRU part number is 03N6345 or 03N5280.

Note: The FRU part numbers are interchangeable. Order the FRU part number that matches the FRU part number you are replacing.

Failing function code 453

The problem is a 146.8 GB 10K RPM SCSI disk drive/carrier.

The FRU part number is 00P3837, 00P2669, or 03N6330.

Note: The FRU part numbers are interchangeable. Order the FRU part number that matches the FRU part number you are replacing.

Failing function code 458

The problem is a 36 GB DAT tape drive.

The FRU part number is 71P9163.

Failing function code 459

The problem is a 36 GB DAT72 tape drive.

The FRU part number for the 36/72GB 4mm DAT72 SAS Tape Drive is 23R2530.

The FRU part number for the 36/72GB 4mm DAT72 LVD Tape Drive is 95P1988.

Failing function code 541

The problem is a 40 GB tape drive.

See the following table for the FRU part number:

CCIN	Description	Model, expansion unit, or unit type	Part number
	40 GB tape drive 40 GB tape drive	7205-440 7337-360	19P2042 19P1629

Failing function code 542

The problem is a tape drive.

See the following table for the FRU part number:

CCIN	Description	Model, expansion unit, or unit type	Part number
	60 GB tape drive	7208-345 7334-410	19P0708 19P0207

Failing function code 56B

The problem is a 36.4 GB 15K RPM disk drive.

The FRU part number is 07N6777.

Failing function code 56D

The problem is a 36.4 GB 15K RPM Ultra3 SCSI disk drive/carrier.

The FRU part number is 80P3161 or 00P2697.

Note: The FRU part numbers are interchangeable. Order the FRU part number that matches the FRU part number you are replacing.

Failing function code 57B

The problem is a 73.4 GB 10K RPM, 68-pin Ultra LVD SCSI disk drive.

The FRU part number is 09P4882 07N3172, 00P3069, 80P3153, or 80P3397.

Note: The FRU part numbers are interchangeable. Order the FRU part number that matches the FRU part number you are replacing.

Failing function code 57D

The problem is a 73.4 GB 10K RPM, 80-pin SCSI disk drive/carrier.

The FRU part number is 09P3928 or 09P4890.

Note: The FRU part numbers are interchangeable. Order the FRU part number that matches the FRU part number you are replacing.

Failing function code 58B

The problem is a 9.1 GB 10K RPM SCSI disk drive/carrier.

The FRU part number is 09P4874 or 09P3921.

Note: The FRU part numbers are interchangeable. Order the FRU part number that matches the FRU part number you are replacing.

Failing function code 58D

The problem is a 18.2 GB 10K RPM SCSI disk drive/carrier.

The FRU part number is 00P3829 or 00P3064.

Note: The FRU part numbers are interchangeable. Order the FRU part number that matches the FRU part number you are replacing.

Failing function code 59B

The problem is a 36.4 GB 10K RPM SCSI disk drive/carrier.

The FRU part number is 00P3831 or 00P3068.

Note: The FRU part numbers are interchangeable. Order the FRU part number that matches the FRU part number you are replacing.

Failing function code 601

The problem is a 9.1 GB LVD 68-pin SCSI disk drive.

See the following table for the FRU part number:

CCIN	Description	Model, expansion unit, or unit type	Part number
	9.1 GB LVD 68-pin SCSI disk drive 9.1 GB LVD 68-pin drive/carrier (U2) 9.1 GB LVD 68-pin drive/carrier (SP) Note: The FRU part numbers are interchangeable. Order the FRU part number that matches the FRU part number you are replacing.	Any	07N3675 03N3873 31L8768

Failing function code 60B

The problem is a 18.2 GB LVD 10K RPM, 68-pin SCSI disk drive.

The FRU part number is 07N4813, 09P4429, 07N3174, 00P3061, or 80P3149.

Note: The FRU part numbers are interchangeable. Order the FRU part number that matches the FRU part number you are replacing.

Failing function code 613

The problem is a 8 mm 80 GB VXA-2 tape device.

The FRU part number is 95P1871.

Failing function code 61B

The problem is a 36.4 GB 10K RPM, 80-pin SCSI disk drive.

The FRU part number is 07N4833, 09P4443, 07N3177, 00P3067, or 80P3152.

Note: The FRU part numbers are interchangeable. Order the FRU part number that matches the FRU part number you are replacing.

Failing function code 61D

The 36.4 GB 10K RPM drive/carrier might be failing.

Use the following table to determine the part number for the field replaceable unit (FRU):

CCIN or FFC	Type and model	Part number	Description	Location code
61D	Any	00P1519	36.4 GB 10K RPM drive/carrier	

Failing function code 61E

The 18.2 GB 10K RPM drive/carrier might be failing.

Use the following table to determine the part number for the field replaceable unit (FRU):

CCIN or FFC	Type and model	Part number	Description	Location code
61E	Any	00P1511	18.2 GB 10K RPM drive/carrier	

Failing function code 621

The problem is a 9.1 GB LVD 80-pin drive/carrier (U2).

The FRU part number is 03N3301.

Failing function code 623

The problem is an 18.2 GB LVD 68-pin SCSI disk drive.

See the following table for the FRU part number:

CCIN	Description	Model, expansion unit, or unit type	Part number
	18.2 GB LVD 68-pin SCSI disk drive 18.2 GB LVD 68-pin drive/carrier (U2) 18.2 GB LVD 68-pin drive/carrier (SP)	Any	07N3674 03N3874 31L8770

Failing function code 624

The problem is an 18.2 GB LVD 80-pin drive/carrier (U2).

The FRU part number is 03N3302.

Failing function code 62D

The 9.1 GB 10K RPM, 68-pin SCSI disk drive might be failing.

Use the following table to determine the part number for the field replaceable unit (FRU):

CCIN or FFC	Type and model	Part number	Description	Location code
62D	Any	09P4868 07N3179 80P3148	9.1 GB 10K RPM, 68-pin SCSI disk drive	

Note: The FRU part numbers are interchangeable. Order the FRU part number that matches the FRU part number you are replacing.

Failing function code 62E

The 9.1 GB 10K RPM drive/carrier might be failing.

Use the following table to determine the part number for the field replaceable unit (FRU):

CCIN or FFC	Type and model	Part number	Description	Location code
62E	Any	00P1508	9.1 GB 10K RPM drive/carrier	

Failing function code 636

The problem is a TURBOWAYS® 622 Mbps PCI MMF ATM adapter.

The FRU part number is 53P1942.

Failing function code 637

The problem is a dual channel PCI-2 Ultra2 SCSI adapter.

The FRU part number is 03N3606.

Failing function code 638

The problem is a 4.5 GB 16-bit Ultra SCSI SE disk drive.

The FRU part number is 22L0027.

Failing function code 639

The problem is a 9.1 GB Ultra SCSI disk drive (68-pin).

See the following table for the FRU part number:

CCIN	Description	Model, expansion unit, or unit type	Part number
	9.1 GB Ultra SCSI Disk Drive (68-pin) Spacer Tray ID cable Screw	Any	34L2232 08L1155 06H9389 06H7691 1147429

Failing function code 63A

The 9.1 GB 10K RPM, 68-pin SCSI disk drive might be failing.

Use the following table to determine the part number for the field replaceable unit (FRU):

CCIN or FFC	Type and model	Part number	Description	Location code
63A	Any	09P4868 07N3179, 80P3148	9.1 GB 10K RPM, 68-pin SCSI disk drive	

Note: The FRU part numbers are interchangeable. Order the FRU part number that matches the FRU part number you are replacing.

Failing function code 63B

The problem is a 9.1 GB 10K RPM, 80-pin SCSI disk drive.

The FRU part number is 07N4853.

Failing function code 63C

The problem is a 18.2 GB LVD 10K RPM, 68-pin SCSI disk drive.

The FRU part number is 07N4813, 09P4429, 07N3174, 00P3061, or 80P3149.

Note: The FRU part numbers are interchangeable. Order the FRU part number that matches the FRU part number you are replacing.

Failing function code 63D

The problem is a disk drive failure.

Go to the service guide for the system on which you are working.

Failing function code 63E

The problem is a 36.4 GB 10K RPM, 68-pin SCSI disk drive.

The FRU part number is 07N4803, 09P4439, 07N3173, 00P3065, or 80P3151.

Note: The FRU part numbers are interchangeable. Order the FRU part number that matches the FRU part number you are replacing.

Failing function code 63F

The problem is a 36.4 GB 10K RPM, 80-pin SCSI disk drive.

The FRU part number is 07N4833, 09P4443, 07N3177, 00P3067, or 80P3152.

Note: The FRU part numbers are interchangeable. Order the FRU part number that matches the FRU part number you are replacing.

Failing function code 640

The 9.1 GB Ultra SCSI disk drive (80-pin) might be failing.

Use the following table to determine the part number for the field replaceable unit (FRU):

CCIN or FFC	Type and model	Part number	Description	Location code
640	Any	34L2233	9.1 GB ultra SCSI disk drive (80-pin)	

Failing function code 643

The 18.2 GB Ultra LVD SCSI disk drive might be failing.

Use the following table to determine the part number for the field replaceable unit (FRU):

CCIN or FFC	Type and model	Part number	Description	Location code
643	Any	09L3116	18.2 GB ultra LVD SCSI disk drive	

Failing function code 644

The 36.2 GB Ultra LVD SCSI disk drive might be failing.

Use the following table to determine the part number for the field replaceable unit (FRU):

CCIN or FFC	Type and model	Part number	Description	Location code
644	Any	09L3339	36.2 GB ultra LVD SCSI disk drive	

Failing function code 646

The high-speed token-ring PCI adapter might be failing.

Use the following table to determine the part number for the field replaceable unit (FRU):

CCIN or FFC	Type and model	Part number	Description	Location code
646	Any	03N3554	High-speed token-ring PCI adapter	

Failing function code 64A

The 9.1 GB 10K RPM drive/carrier might be failing.

Use the following table to determine the part number for the field replaceable unit (FRU):

CCIN or FFC	Type and model	Part number	Description	Location code
64A	Any	00P1508	9.1 GB 10K RPM drive/carrier	

Failing function code 64B

The 9.1 GB LVD 80-pin drive/carrier might be failing.

Use the following table to determine the part number for the field replaceable unit (FRU):

CCIN or FFC	Type and model	Part number	Description	Location code
64B	Any	00P1517	9.1 GB LVD 80-pin drive/carrier	

Failing function code 64C

The 18.2 GB 10K RPM drive/carrier might be failing.

Use the following table to determine the part number for the field replaceable unit (FRU):

CCIN or FFC	Type and model	Part number	Description	Location code
64C	Any	00P1511	18.2 GB 10K RPM drive/carrier	

Failing function code 64D

The 18.2 GB LVD 80-pin drive/carrier might be failing.

Use the following table to determine the part number for the field replaceable unit (FRU):

CCIN or FFC	Type and model	Part number	Description	Location code
64D	Any	00P1520	18.2 GB LVD 80-pin drive/carrier	

Failing function code 64E

The 36.4 GB 10K RPM drive/carrier might be failing.

Use the following table to determine the part number for the field replaceable unit (FRU):

CCIN or FFC	Type and model	Part number	Description	Location code

64E	Any	00P1514	36.4 GB 10K RPM drive/carrier	
-----	-----	---------	-------------------------------	--

Failing function code 64F

The 36.4 GB 10K RPM drive/carrier might be failing.

Use the following table to determine the part number for the field replaceable unit (FRU):

CCIN or FFC	Type and model	Part number	Description	Location code
64F	Any	00P1519	36.4 GB 10K RPM drive/carrier	

Failing function code 650

The disk drive might be failing.

Use the following table to determine the part number for the field replaceable unit (FRU):

CCIN or FFC	Type and model	Part number	Description	Location code
650	Any	* See note.	Unknown disk drive	

Note: This FFC indicates that the disk drive could not properly configure. Refer to the disk drive FRU part number.

Failing function code 653

The 18.2 GB Ultra-SCSI 16-bit disk drive might be failing.

Use the following table to determine the part number for the field replaceable unit (FRU):

CCIN or FFC	Type and model	Part number	Description	Location code
653	Any	59H6923	18.2 GB Ultra-SCSI 16-bit disk drive	

Failing function code 655

The graphics adapter might be failing.

Use the following table to determine the part number for the field replaceable unit (FRU):

CCIN or FFC	Type and model	Part number	Description	Location code
655	Any	11K0313	GXT130P PCI Graphics Adapter	

Failing function code 657

The graphics adapter might be failing.

Use the following table to determine the part number for the field replaceable unit (FRU):

CCIN or FFC	Type and model	Part number	Description	Location code
-------------	----------------	-------------	-------------	---------------

657	Any	07L7495	GXT2000P 3D graphics adapter PCI	
-----	-----	---------	----------------------------------	--

Failing function code 65A

See failing function code 67E.

Failing function code 65B

This failing function code is no longer used.

Failing function code 65E

See failing function code 254A.

Failing function code 65F

See failing function code 254B.

Failing function code 662

A backplane might be failing.

Use the following table to determine the part number for the field replaceable unit (FRU):

CCIN or FFC	Type and model	Part number	Description	Location code
662	8203-E4A, 9407-M15, 9408-M25	42R7898	System backplane	Un-P1
662	8204-E8A, 9409-M50	10N9369	System backplane	Un-P1
662	9117-MMA	42R7352	I/O backplane	

Failing function code 663

An adapter might be failing.

Use the following table to determine the part number for the field replaceable unit (FRU):

CCIN or FFC	Type and model	Part number	Description	Location code
663		87H3734	IBM ARTIC960RxD PCI adapter (base card)	
663		47L8851	IBM ARTIC960RxF adapter	
663		09J8829	IBM ARTIC960 Quad T1/E1 adapter (daughter card)	

Failing function code 664

The SCSI-2 CD-ROM drive might be failing.

Use the following table to determine the part number for the field replaceable unit (FRU):

CCIN or FFC	Type and model	Part number	Description	Location code
-------------	----------------	-------------	-------------	---------------

664	Any	04N2967	SCSI-2 CD-ROM Drive	
-----	-----	---------	---------------------	--

Failing function code 667

The PCI 3-channel Ultra2 SCSI RAID adapter might be failing.

Use the following table to determine the part number for the field replaceable unit (FRU):

CCIN or FFC	Type and model	Part number	Description	Location code
667	Any	01K7396	PCI 3-Channel Ultra2 SCSI RAID Adapter	

Failing function code 669

The PCI Gigabit ethernet adapter might be failing.

Use the following table to determine the part number for the field replaceable unit (FRU):

CCIN or FFC	Type and model	Part number	Description	Location code
669	Any	41L6396	PCI Gigabit Ethernet adapter	

Failing function code 66A

The keyboard/mouse USB PCI attachment card might be failing.

Use the following table to determine the part number for the field replaceable unit (FRU):

CCIN or FFC	Type and model	Part number	Description	Location code
66A	Any	09P2470	Keyboard/mouse USB PCI attachment card	

Failing function code 66C

The 10/100/1000 base-T ethernet PCI adapter might be failing.

Use the following table to determine the part number for the field replaceable unit (FRU):

CCIN or FFC	Type and model	Part number	Description	Location code
66C	Any	00P1690	10/100/1000 base-T Ethernet PCI adapter	

Failing function code 66D

The PCI 4-channel Ultra3 SCSI RAID adapter might be failing.

Use the following table to determine the part number for the field replaceable unit (FRU):

CCIN or FFC	Type and model	Part number	Description	Location code
-------------	----------------	-------------	-------------	---------------

66D	Any	37L6892	PCI 4-channel ultra3 SCSI RAID adapter (base card only)	
-----	-----	---------	---	--

Failing function code 66E

The DVD-RAM drive might be failing.

Use the following table to determine the part number for the field replaceable unit (FRU):

CCIN or FFC	Type and model	Part number	Description	Location code
66E	Any	04N5967	4.7 GB DVD-RAM drive, black bezel	
66E	Any	04N5968	4.7 GB DVD-RAM drive, white bezel	

Failing function code 670

18.2 GB SCSI 80-pin SCA driver configuration.

Failing function code 671

9.1 GB SCSI 80-pin SCA driver configuration.

Failing function code 672

9.1 GB SCSI differential drive configuration.

Failing function code 673

The 18.2 GB differential SCSI disk drive might be failing.

Use the following table to determine the part number for the field replaceable unit (FRU):

CCIN or FFC	Type and model	Part number	Description	Location code
673	Any	59H6925	18.2 GB differential SCSI disk drive	

Failing function code 674

An adapter might be failing.

Use the following table to determine the part number for the field replaceable unit (FRU):

CCIN or FFC	Type and model	Part number	Description	Location code
674	Any	31L7567	ESCON [®] channel PCI adapter assembly	
674	Any	39H8084	IBM ARTIC960Rx PCI base adapter	

Failing function code 675

An adapter might be failing.

Use the following table to determine the part number for the field replaceable unit (FRU):

CCIN or FFC	Type and model	Part number	Description	Location code
675	Any	87H3427	IBM ARTIC960Hx PCI base adapter	

Failing function code 677

The PCI 32-bit fibre channel adapter might be failing.

Use the following table to determine the part number for the field replaceable unit (FRU):

CCIN or FFC	Type and model	Part number	Description	Location code
677	Any	09P1173	PCI 32-Bit Fibre Channel adapter	

Failing function code 678

The 12 GB 4 mm SCSI tape drive might be failing.

Use the following table to determine the part number for the field replaceable unit (FRU):

CCIN or FFC	Type and model	Part number	Description	Location code
678	Any	59H3879	12 GB 4 mm SCSI tape drive	

Failing function code 679

The 4.5 GB SCSI disk drive might be failing.

Use the following table to determine the part number for the field replaceable unit (FRU):

CCIN or FFC	Type and model	Part number	Description	Location code
679	Any	83H7105	4.5 GB SCSI disk drive	

Failing function code 67B

The cryptographic coprocessor card might be failing.

Use the following table to determine the part number for the field replaceable unit (FRU):

CCIN or FFC	Type and model	Part number	Description	Location code
67B	Any	See Managing PCI adapters.	PCI cryptographic coprocessor card	

Failing function code 67E

The graphics adapter might be failing.

Use the following table to determine the part number for the field replaceable unit (FRU):

CCIN or FFC	Type and model	Part number	Description	Location code
-------------	----------------	-------------	-------------	---------------

67E	Any	03N5853	GXT135P PCI graphics adapter	
-----	-----	---------	------------------------------	--

Failing function code 681

The 9.1 GB Ultra-SCSI 16-bit drive might be failing.

Use the following table to determine the part number for the field replaceable unit (FRU):

CCIN or FFC	Type and model	Part number	Description	Location code
681	Any	59H6926	9.1 GB ultra-SCSI 16-bit drive	

Failing function code 682

The CD-ROM drive might be failing.

Use the following table to determine the part number for the field replaceable unit (FRU):

CCIN or FFC	Type and model	Part number	Description	Location code
682	Any	93H8055	20X (MAX) SCSI-2 CD-ROM Drive	

Failing function code 683

The 2105 might be failing.

Use the following table to determine the part number for the field replaceable unit (FRU):

CCIN or FFC	Type and model	Part number	Description	Location code
683	Any		2105 - all models	

Failing function code 684

The remote asynchronous node might be failing.

Use the following table to determine the part number for the field replaceable unit (FRU):

CCIN or FFC	Type and model	Part number	Description	Location code
684	Any	93H6563	Enhanced remote asynchronous node, 16-Port RS-422	
684	Any	93H7091	power supply, remote async node	

Failing function code 685

The video accelerator adapter might be failing.

Use the following table to determine the part number for the field replaceable unit (FRU):

CCIN or FFC	Type and model	Part number	Description	Location code
-------------	----------------	-------------	-------------	---------------

685	Any	93H2534	GXT120P 2D Video Accelerator Adapter PCI	
-----	-----	---------	--	--

Failing function code 686

The 8-port asynchronous EIA-232/RS-422 adapter might be failing.

Use the following table to determine the part number for the field replaceable unit (FRU):

CCIN or FFC	Type and model	Part number	Description	Location code
686	Any	93H6541	8-port asynchronous EIA-232/RS-422 adapter	

Failing function code 687

The 128-port asynchronous controller might be failing.

Use the following table to determine the part number for the field replaceable unit (FRU):

CCIN or FFC	Type and model	Part number	Description	Location code
687	Any	93H6545	128-port asynchronous controller	

Failing function code 689

The 4.5 GB 16-bit Ultra SCSI SE disk drive might be failing.

Use the following table to determine the part number for the field replaceable unit (FRU):

CCIN or FFC	Type and model	Part number	Description	Location code
689	Any	83H7105	4.5 GB 16-bit ultra SCSI SE disk drive	
689	Any	93H9005	4.5 GB 16-bit ultra SCSI SE disk drive assembly	

Failing function code 68C

The 20 GB 4 mm tape drive might be failing.

Use the following table to determine the part number for the field replaceable unit (FRU):

CCIN or FFC	Type and model	Part number	Description	Location code
68C	Any	19P0802	20 GB 4 mm tape drive	

Failing function code 68E

The graphics adapter might be failing.

Use the following table to determine the part number for the field replaceable unit (FRU):

CCIN or FFC	Type and model	Part number	Description	Location code
68E	Any	00P2368	POWER™ GXT6000P graphics adapter	

Failing function code 690

The 9.1 GB 16-bit Ultra SCSI SE disk drive might be failing.

Use the following table to determine the part number for the field replaceable unit (FRU):

CCIN or FFC	Type and model	Part number	Description	Location code
690	Any	76H2698	9.1 GB 16-bit ultra SCSI SE disk drive	

Failing function code 691

An adapter might be failing.

Use the following table to determine the part number for the field replaceable unit (FRU):

CCIN or FFC	Type and model	Part number	Description	Location code
691	Any	93H5513	TURBOWAYS 25 ATM PCI Adapter	

Failing function code 692

A tape drive might be failing.

Use the following table to determine the part number for the field replaceable unit (FRU):

CCIN or FFC	Type and model	Part number	Description	Location code
692	Any	59H3121	7205-311 35 GB DLT tape drive	
692	Any	59H3569	3447-105 35 GB DLT tape drive	
692	Any	59H3569	3447-106 35 GB DLT tape drive	
692	Any	59H3570	7337-305 35 GB DLT tape drive	
692	Any	59H3570	7337-306 35 GB DLT tape drive	

Failing function code 693

An adapter might be failing.

Use the following table to determine the part number for the field replaceable unit (FRU):

CCIN or FFC	Type and model	Part number	Description	Location code
-------------	----------------	-------------	-------------	---------------

693	Any	93H5839	Eicon ISDN DIVA PRO 2.0 PCI S/T adapter for PowerPC® System	
-----	-----	---------	---	--

Failing function code 697

An adapter might be failing.

Use the following table to determine the part number for the field replaceable unit (FRU):

CCIN or FFC	Type and model	Part number	Description	Location code
697	Any	21H3890	TURBOWAYS® 155 PCI MMF ATM adapter (1 MB)	

Failing function code 698

An adapter might be failing.

Use the following table to determine the part number for the field replaceable unit (FRU):

CCIN or FFC	Type and model	Part number	Description	Location code
698	Any	21H7977	TURBOWAYS 155 PCI UTP ATM adapter (1 MB)	

Failing function code 699

An adapter might be failing.

Use the following table to determine the part number for the field replaceable unit (FRU):

CCIN or FFC	Type and model	Part number	Description	Location code
699	Any	94H0385	3Com Fast EtherLink XL PCI 10/100 Ethernet for PowerPC Microprocessor-based Systems	

Failing function code 69B

An adapter might be failing.

Use the following table to determine the part number for the field replaceable unit (FRU):

CCIN or FFC	Type and model	Part number	Description	Location code
69B	Any	21P4106	64-bit/66 MHz PCI ATM MMF adapter	

Failing function code 69D

An adapter might be failing.

Use the following table to determine the part number for the field replaceable unit (FRU):

CCIN or FFC	Type and model	Part number	Description	Location code
69D	Any	21P4112	64-bit/66 MHz PCI ATM 155 UTP adapter	

Failing function code 6C9

A SCSI DVD-ROM drive might be failing.

Use the following table to determine the part number for the field replaceable unit (FRU):

CCIN or FFC	Type and model	Part number	Description	Location code
6C9	Any	53P2799	SCSI DVD-ROM Drive	

Failing function code 6CC

An SSA drive might be failing.

Use the following table to determine the part number for the field replaceable unit (FRU):

CCIN or FFC	Type and model	Part number	Description	Location code
6CC	Any	59H6259	4.5 GB SSA drive (DCHC/DGHC) in a blue-handled carrier	
6CC	Any	21H8734	9.1 GB 1.6-inch SSA drive (DCHC) in a blue-handled carrier	
6CC	Any	05J6446	9.1 GB 1.0-inch SSA drive (DGHC) in a blue-handled carrier	

Failing function code 700

The 1.1 GB 8-bit SE disk drive assembly might be failing.

Use the following table to determine the part number for the field replaceable unit (FRU):

CCIN or FFC	Type and model	Part number	Description	Location code
700	Any	74G6995	1.1 GB 8-bit SE disk drive assembly	

Failing function code 701

The disk drive might be failing.

Use the following table to determine the part number for the field replaceable unit (FRU):

CCIN or FFC	Type and model	Part number	Description	Location code
701	Any	74G7006	1.1 GB 16-bit SE disk drive assembly	

701	Any	06H8631	tray assembly	
701	Any	06H7691	4 position ID cable	
701	Any	27H0380	electronics card assembly	

Failing function code 702

The disk drive might be failing.

Use the following table to determine the part number for the field replaceable unit (FRU):

CCIN or FFC	Type and model	Part number	Description	Location code
702	Any	74G7009	1.1 GB 16-bit DE disk drive assembly	
702	Any	74G7015	Electronics card assembly	

Failing function code 703

The disk drive might be failing.

Use the following table to determine the part number for the field replaceable unit (FRU):

CCIN or FFC	Type and model	Part number	Description	Location code
703	Any	74G6996	2.2 GB 8-bit SE disk drive	
703	Any	74G6998	Electronics card assembly	

Failing function code 704

The disk drive might be failing.

Use the following table to determine the part number for the field replaceable unit (FRU):

CCIN or FFC	Type and model	Part number	Description	Location code
704	Any	74G8824	2.2 GB 16-bit SE disk drive assembly	
704	Any	74G7007	2.2 GB 16-bit SE disk drive unit	
704	Any	06H8631	tray assembly	
704	Any	06H7691	4 position ID cable	
704	Any	27H0380	Electronics card assembly	

Failing function code 705

The disk drive might be failing.

Use the following table to determine the part number for the field replaceable unit (FRU):

CCIN or FFC	Type and model	Part number	Description	Location code
-------------	----------------	-------------	-------------	---------------

705	Any	74G7010	2.2 GB 16-bit DE disk drive assembly	
705	Any	74G7015	electronics card assembly	

Failing function code 706

The disk drive might be failing.

Use the following table to determine the part number for the field replaceable unit (FRU):

CCIN or FFC	Type and model	Part number	Description	Location code
706	Any	74G7008	4.5 GB 16-bit SE disk drive	
706	Any	74G8825	4.5 GB 16-bit SE disk drive assembly	
706	Any	06H8631	Tray assembly	
706	Any	06H7691	4 position ID cable	
706	Any	27H0380	electronics card assembly	

Failing function code 707

The disk drive might be failing.

Use the following table to determine the part number for the field replaceable unit (FRU):

CCIN or FFC	Type and model	Part number	Description	Location code
707	Any	74G7011	4.5 GB 16-bit DE disk drive assembly	
707	Any	74G7015	Electronics card assembly	

Failing function code 709

The 128-port ISA adapter might be failing.

Use the following table to determine the part number for the field replaceable unit (FRU):

CCIN or FFC	Type and model	Part number	Description	Location code
	Any	73H3384	128-port ISA Adapter	

Failing function code 711

The adapter might be failing.

Use the following table to determine the part number for the field replaceable unit (FRU):

CCIN or FFC	Type and model	Part number	Description	Location code
711	Any		Unknown adapter	

Failing function code 713

The adapter might be failing.

Use the following table to determine the part number for the field replaceable unit (FRU):

CCIN or FFC	Type and model	Part number	Description	Location code
711	Any	87H3427	IBM ARTIC960Hx PCI base adapter	

Failing function code 716

The system memory might be failing.

Failing function code 717

The ethernet adapter is being configured.

Failing function code 721

The SCSI device might be failing.

Use the following table to determine the part number for the field replaceable unit (FRU):

CCIN or FFC	Type and model	Part number	Description	Location code
721	Any		Unknown SCSI device	

Failing function code 722

The disk drive might be failing.

Use the following table to determine the part number for the field replaceable unit (FRU):

CCIN or FFC	Type and model	Part number	Description	Location code
	Any		Unknown disk drive	

Failing function code 723

The CD-ROM drive might be failing.

Use the following table to determine the part number for the field replaceable unit (FRU):

CCIN or FFC	Type and model	Part number	Description	Location code
723	Any		Unknown CD-ROM drive	

Failing function code 724

The tape drive might be failing.

Use the following table to determine the part number for the field replaceable unit (FRU):

CCIN or FFC	Type and model	Part number	Description	Location code
724	Any		Unknown tape drive	

Failing function code 725

The display might be failing.

Use the following table to determine the part number for the field replaceable unit (FRU):

CCIN or FFC	Type and model	Part number	Description	Location code
725	Any	96G2130	P50, Display, 15-inch, northern hemisphere	
725	Any	96G2699	P50, Display, 15-inch, southern hemisphere	
725	Any	96G3020	P70, Display, 17-inch, northern hemisphere	
725	Any	96G2150	P70, Display, 17-inch, southern hemisphere	
725	Any	21L4570	P72, Display, 17-inch, northern (white)	
725	Any	21L4571	P72, Display, 17-inch, northern (black)	
725	Any	61H0215	P72, Display, 17-inch, southern (white)	
725	Any	61H0216	P72, Display, 17-inch, southern (black)	
725	Any	61H0412	P92, Display, 19-inch, northern (white)	
725	Any	61H0223	P92, Display, 19-inch, northern (black)	
725	Any	61H0224	P92, Display, 19-inch, southern (white)	
725	Any	61H0225	P92, Display, 19-inch, southern (black)	
725	Any	96G2701	P200, Display, 20-inch, northern hemisphere	
725	Any	96G3049	P200, Display, 20-inch, southern hemisphere	
725	Any	60H0233	P202, Display, 21-inch, northern (white)	
725	Any	60H0234	P202, Display, 21-inch, northern (black)	
725	Any	60H0235	P202, Display, 21-inch, southern (white)	
725	Any	60H0236	P202, Display, 21-inch, southern (black)	
725	Any		Unknown adapter type	

Failing function code 726

The input device might be failing.

Use the following table to determine the part number for the field replaceable unit (FRU):

CCIN or FFC	Type and model	Part number	Description	Location code
726	Any		Unknown input device	

Failing function code 727

The async device might be failing.

Use the following table to determine the part number for the field replaceable unit (FRU):

CCIN or FFC	Type and model	Part number	Description	Location code
727	Any		Unknown async device	

Failing function code 728

The device might be failing.

Use the following table to determine the part number for the field replaceable unit (FRU):

CCIN or FFC	Type and model	Part number	Description	Location code
728	Any		Unknown parallel device	

Failing function code 730

The diskette drive might be failing.

Use the following table to determine the part number for the field replaceable unit (FRU):

CCIN or FFC	Type and model	Part number	Description	Location code
730	Any		Unknown diskette drive	

Failing function code 733

The 140 GB 8 mm tape library might be failing.

Use the following table to determine the part number for the field replaceable unit (FRU):

CCIN or FFC	Type and model	Part number	Description	Location code
733	Any	59H3161	140 GB 8 mm tape library	

Failing function code 734

The CD-ROM drive might be failing.

Use the following table to determine the part number for the field replaceable unit (FRU):

CCIN or FFC	Type and model	Part number	Description	Location code
734	Any	73H1513	Quad Speed SCSI-2 600 MB CD-ROM Drive	

Failing function code 736

The keyboard and speaker cable might be failing.

Use the following table to determine the part number for the field replaceable unit (FRU):

CCIN or FFC	Type and model	Part number	Description	Location code
736	Any	The part number is printed on the underside of the keyboard.	Quiet touch keyboard and speaker cable	

Failing function code 741

The disk drive might be failing.

Use the following table to determine the part number for the field replaceable unit (FRU):

CCIN or FFC	Type and model	Part number	Description	Location code
741	Any	52G0124	1.08 GB SCSI-2 disk drive (1-inch high)	
741	Any	06H8631	8-bit tray assembly	

Failing function code 742

The T2 PCI ethernet adapter might be failing.

Use the following table to determine the part number for the field replaceable unit (FRU):

CCIN or FFC	Type and model	Part number	Description	Location code
742	Any	11H8128	T2 PCI Ethernet Adapter	

Failing function code 745

The tape cartridge auto loader might be failing.

Use the following table to determine the part number for the field replaceable unit (FRU):

CCIN or FFC	Type and model	Part number	Description	Location code
745	7332-005	Service documentation for this device supplies the FRU part numbers.	16 GB DDS-2 tape cartridge auto loader	

	Any	Service documentation for this device supplies the FRU part numbers.	48 GB DDS-3 tape cartridge auto loader	
--	-----	--	--	--

Failing function code 746

The SCSI-2 fast/wide PCI adapter might be failing.

Use the following table to determine the part number for the field replaceable unit (FRU):

CCIN or FFC	Type and model	Part number	Description	Location code
746	Any	73H3562	SCSI-2 Fast/Wide PCI Adapter	

Failing function code 747

The SCSI-2 differential fast/wide PCI adapter might be failing.

Use the following table to determine the part number for the field replaceable unit (FRU):

CCIN or FFC	Type and model	Part number	Description	Location code
747	Any	93H8407	SCSI-2 differential fast/wide PCI adapter	

Failing function code 749

The 8 mm tape library might be failing.

Use the following table to determine the part number for the field replaceable unit (FRU):

CCIN or FFC	Type and model	Part number	Description	Location code
749	7331 model 205	For FRU numbers, refer to the service documentation for this device.	8 mm tape library	

Failing function code 74A

The SCSI-2 fast/wide PCI adapter might be failing.

Use the following table to determine the part number for the field replaceable unit (FRU):

CCIN or FFC	Type and model	Part number	Description	Location code
74A	Any	93H4808	SCSI-2 Fast/Wide PCI Adapter	

Failing function code 750

The token-ring PCI adapter might be failing.

Use the following table to determine the part number for the field replaceable unit (FRU):

CCIN or FFC	Type and model	Part number	Description	Location code
750	Any	04H8098	Auto LANStreamer® Token-Ring PCI Adapter	

Failing function code 751

The adapter might be failing.

Use the following table to determine the part number for the field replaceable unit (FRU):

CCIN or FFC	Type and model	Part number	Description	Location code
751	Any	08L1319	SCSI 32-bit SE F/W RAID Adapter	
751	Any	06H6036	SCSI RAID Cable (1.0 m)	
751	Any	52G4233	SCSI RAID Cable (2.5 m)	
751	Any	40H7351	SCSI RAID Cable (6.0 m)	

Failing function code 757

The SCSI 13 GB 1/4 inch tape drive might be failing.

Use the following table to determine the part number for the field replaceable unit (FRU):

CCIN or FFC	Type and model	Part number	Description	Location code
757	Any	87G4858	SCSI 13 GB 1/4 inch tape drive	

Failing function code 759

The 1080 MB disk drive might be failing.

Use the following table to determine the part number for the field replaceable unit (FRU):

CCIN or FFC	Type and model	Part number	Description	Location code
759	Any	87G8976	1080 MB disk drive	

Failing function code 763

The adapter might be failing.

Use the following table to determine the part number for the field replaceable unit (FRU):

CCIN or FFC	Type and model	Part number	Description	Location code
763	Any	31L7847	SP switch MX adapter	
763	Any	46H9688	wrap plug	

763	Any	77G0818	terminator	
-----	-----	---------	------------	--

Failing function code 764

The adapter might be failing.

Use the following table to determine the part number for the field replaceable unit (FRU):

CCIN or FFC	Type and model	Part number	Description	Location code
764	Any	08L0398	SP system attachment adapter	
764	Any	46H9688	wrap plug	
764	Any	77G0818	terminator	

Failing function code 772

The 4.5 GB 16-bit SCSI F/W disk drive might be failing.

Use the following table to determine the part number for the field replaceable unit (FRU):

CCIN or FFC	Type and model	Part number	Description	Location code
772	Any	83H7105	4.5 GB 16-bit SCSI F/W disk drive	

Failing function code 773

The 9.1 GB 16-bit SCSI F/W disk drive might be failing.

Use the following table to determine the part number for the field replaceable unit (FRU):

CCIN or FFC	Type and model	Part number	Description	Location code
773	Any	76H2698	9.1 GB 16-bit SCSI F/W disk drive	

Failing function code 774

The 9.1 GB external SCSI DE disk drive might be failing.

Use the following table to determine the part number for the field replaceable unit (FRU):

CCIN or FFC	Type and model	Part number	Description	Location code
774	Any	27H1677	9.1 GB external SCSI DE disk drive	

Failing function code 775

The graphics adapter might be failing.

Use the following table to determine the part number for the field replaceable unit (FRU):

CCIN or FFC	Type and model	Part number	Description	Location code
775	Any	93H5107	MVP Power Graphics Adapter	

Failing function code 776

The token-ring adapter might be failing.

Use the following table to determine the part number for the field replaceable unit (FRU):

CCIN or FFC	Type and model	Part number	Description	Location code
776	Any	93H6594	PCI token-ring adapter	

Failing function code 777

The 10/100 Base-TX ethernet PCI adapter might be failing.

Use the following table to determine the part number for the field replaceable unit (FRU):

CCIN or FFC	Type and model	Part number	Description	Location code
777	Any	94H0823	10/100 Base-TX Ethernet PCI Adapter	

Failing function code 778

The graphics adapter might be failing.

Use the following table to determine the part number for the field replaceable unit (FRU):

CCIN or FFC	Type and model	Part number	Description	Location code
778	Any	24L0030	POWER GXT3000P 3D graphics adapter PCI	

Failing function code 77B

The 4-port 10/100 ethernet Tx PCI adapter might be failing.

Use the following table to determine the part number for the field replaceable unit (FRU):

CCIN or FFC	Type and model	Part number	Description	Location code
77B	Any	03N3952	4-port 10/100 Ethernet Tx PCI Adapter	
77B	Any	09P1421	4-port 10/100 Ethernet Tx PCI Adapter (new chip)	

Failing function code 77C

A 1 GB 16 bit SE SCSI disk drive is being configured.

Failing function code 780

The X.25 interface coprocessor adapter might be failing.

Use the following table to determine the part number for the field replaceable unit (FRU):

CCIN or FFC	Type and model	Part number	Description	Location code
780	Any	40H1937	X.25 interface coprocessor adapter	

Failing function code 781

The coprocessor multiport adapter might be failing.

Use the following table to determine the part number for the field replaceable unit (FRU):

CCIN or FFC	Type and model	Part number	Description	Location code
781	Any	84F7540	Coprocessor multiport adapter, model 2 (daughter) Note: Replace the daughter card before replacing the base card.	
781	Any	33F8967	Coprocessor multiport adapter, model 2 (base)	

Failing function code 783

The 24/48 GB DDS-2 4 mm tape autoloader might be failing.

Use the following table to determine the part number for the field replaceable unit (FRU):

CCIN or FFC	Type and model	Part number	Description	Location code
783	Any	76H0473	24/48 GB DDS-2 4 mm tape autoloader (vertical orientation)	
783	Any	76H0474	24/48 GB DDS-2 4 mm tape autoloader (horizontal orientation)	
783	Any	41H8714	tape magazine	

Failing function code 784

The 2.1 GB SCSI-2 disk drive might be failing.

Use the following table to determine the part number for the field replaceable unit (FRU):

CCIN or FFC	Type and model	Part number	Description	Location code
784	Any	93H7151	2.1 GB 8-bit SCSI-2 disk drive	
784	Any	93H7152	2.1 GB 16-bit SCSI-2 disk drive	

Failing function code 785

The 8-port ISA async EIA-232/RS-422 adapter might be failing.

Use the following table to determine the part number for the field replaceable unit (FRU):

CCIN or FFC	Type and model	Part number	Description	Location code
785	Any	40H6632	8-port ISA Async EIA-232/RS-422 adapter	

Failing function code 786

The graphics adapter might be failing.

Use the following table to determine the part number for the field replaceable unit (FRU):

CCIN or FFC	Type and model	Part number	Description	Location code
786	Any	93H6264	GXT250P high performance graphics adapter	

Failing function code 787

The graphics adapter might be failing.

Use the following table to determine the part number for the field replaceable unit (FRU):

CCIN or FFC	Type and model	Part number	Description	Location code
787	Any	94H0028	GXT500P graphics adapter	

Failing function code 788

The video capture adapter might be failing.

Use the following table to determine the part number for the field replaceable unit (FRU):

CCIN or FFC	Type and model	Part number	Description	Location code
788	Any	07L9009	Ultimedia® Video Capture adapter	

Failing function code 789

The external 2.6 GB rewritable optical disk drive might be failing.

Use the following table to determine the part number for the field replaceable unit (FRU):

CCIN or FFC	Type and model	Part number	Description	Location code
789	Any	50G0212	External 2.6 GB rewritable optical disk drive	

Failing function code 78B

The graphics adapter might be failing.

Use the following table to determine the part number for the field replaceable unit (FRU):

CCIN or FFC	Type and model	Part number	Description	Location code
78B	Any	00P2429	POWER GXT4000P graphics adapter	

Failing function code 78D

The graphics adapter might be failing.

Use the following table to determine the part number for the field replaceable unit (FRU):

CCIN or FFC	Type and model	Part number	Description	Location code
78D	Any	03N4169	GXT300P 2D graphics adapter	

Failing function code 790

The multi-bus integrated ethernet adapter might be failing.

Use the following table to determine the part number for the field replaceable unit (FRU):

CCIN or FFC	Type and model	Part number	Description	Location code
790	Any	42R7352	Multi-bus integrated Ethernet adapter problem, I/O backplane	

Failing function code 791

The 2.2 GB 16-bit SE disk drive assembly might be failing.

Use the following table to determine the part number for the field replaceable unit (FRU):

CCIN or FFC	Type and model	Part number	Description	Location code
791	Any	74G8824	2.2 GB 16-bit SE disk drive assembly	
791	Any	74G7007	2.2 GB 16-bit SE disk drive unit tray assembly	
791	Any	06H8631	tray assembly	
791	Any	06H7691	4 position ID cable	
791	Any	27H0380	electronics card assembly	

Failing function code 792

The 4.5 GB 16-bit SE disk drive assembly might be failing.

Use the following table to determine the part number for the field replaceable unit (FRU):

CCIN or FFC	Type and model	Part number	Description	Location code
792	Any	83H7105	4.5 GB 16-bit SE disk drive assembly	

Failing function code 793

The 9.1 GB 16-bit SE disk drive assembly might be failing.

Use the following table to determine the part number for the field replaceable unit (FRU):

CCIN or FFC	Type and model	Part number	Description	Location code
793	Any	76H2698	9.1 GB 16-bit SE disk drive assembly	

Failing function code 795

The FDDI LPSAS adapter might be failing.

Use the following table to determine the part number for the field replaceable unit (FRU):

CCIN or FFC	Type and model	Part number	Description	Location code
795	Any	73H3405	FDDI LPSAS Adapter (single fiber)	
795	Any	73H3401	FDDI LPDAS Adapter (dual fiber)	
795	Any	73H3413		

Failing function code 799

The 2-port multiprotocol PCI adapter might be failing.

Use the following table to determine the part number for the field replaceable unit (FRU):

CCIN or FFC	Type and model	Part number	Description	Location code
799	Any	93H6086	2-Port Multiprotocol PCI Adapter	
799	Any	93H3662	2-Port Multiprotocol PCI Wrap Plug	

Failing function code 7C0

The system backplane might be failing.

Use the following table to determine the part number for the field replaceable unit (FRU):

CCIN or FFC	Type and model	Part number	Description	Location code
7C0	Any	03N6902	CPU/system interface problem, system backplane	

Failing function code 7C1

The system backplane might be failing.

Use the following table to determine the part number for the field replaceable unit (FRU):

CCIN or FFC	Type and model	Part number	Description	Location code
7C1	Any		Business audio subsystem problem, replace the system unit's system backplane	

Failing function code 804

The 8x speed SCSI-2 CD-ROM drive might be failing.

Use the following table to determine the part number for the field replaceable unit (FRU):

CCIN or FFC	Type and model	Part number	Description	Location code
804	Any	73H2601	8X Speed SCSI-2 CD-ROM Drive	

Failing function code 806

The graphics adapter might be failing.

Use the following table to determine the part number for the field replaceable unit (FRU):

CCIN or FFC	Type and model	Part number	Description	Location code
806	Any	07L7113	GXT800P Graphics Adapter	

Failing function code 807

The SCSI device enclosure might be failing.

Use the following table to determine the part number for the field replaceable unit (FRU):

CCIN or FFC	Type and model	Part number	Description	Location code
807	Any		SCSI device enclosure Note: If the resource description on the screen displays: <ol style="list-style-type: none">1. SES or SCSI Enclosure Services Device, use FFC 199.2. SAFTE or SCSI Accessed Fault-Tolerant Enclosure Device, use FFC 2580.	

Failing function code 80C

The SSA adapter might be failing.

Use the following table to determine the part number for the field replaceable unit (FRU):

CCIN or FFC	Type and model	Part number	Description	Location code
80C	Any		SSA adapter problem refer to the SSA adapters: User's Guide and Maintenance Information.	

Failing function code 811

The processor complex might be failing.

Use the following table to determine the part number for the field replaceable unit (FRU):

CCIN or FFC	Type and model	Part number	Description	Location code
811	Any		Processor complex being identified.	

Failing function code 812

The adapter might be failing.

Use the following table to determine the part number for the field replaceable unit (FRU):

CCIN or FFC	Type and model	Part number	Description	Location code
812	Any		Common standard adapter logic problem Note: For type/model and FRU information refer to FFC 227.	

Failing function code 814

The NIO planar might be failing.

Use the following table to determine the part number for the field replaceable unit (FRU):

CCIN or FFC	Type and model	Part number	Description	Location code
814	Any	11K0571	NIO planar, 9076/POWER3 SMP High Node	

Failing function code 815

Floating point processor problem.

Use the following table to determine the part number for the field replaceable unit (FRU):

CCIN or FFC	Type and model	Part number	Description	Location code
-------------	----------------	-------------	-------------	---------------

815	Any		Floating point processor problem Note: For type/model and FRU information refer to FFC 210.	
-----	-----	--	---	--

Failing function code 816

Operator panel logic problem.

Use the following table to determine the part number for the field replaceable unit (FRU):

CCIN or FFC	Type and model	Part number	Description	Location code
816	Any		Operator panel logic problem Note: If the type/model and FRU information is not listed here, refer to FFC 221.	

Failing function code 817

The system backplane might be failing.

Use the following table to determine the part number for the field replaceable unit (FRU):

CCIN or FFC	Type and model	Part number	Description	Location code
817	Any		system backplane see FFC 221.	

Failing function code 820

Interprocessor related testing problem.

Use the following table to determine the part number for the field replaceable unit (FRU):

CCIN or FFC	Type and model	Part number	Description	Location code
	Any		Interprocessor related testing problem Note: For type/model and FRU information, if not listed here, refer to FFC 221	

Failing function code 821

Standard keyboard adapter problem.

Use the following table to determine the part number for the field replaceable unit (FRU):

CCIN or FFC	Type and model	Part number	Description	Location code
-------------	----------------	-------------	-------------	---------------

821	Any		Standard keyboard adapter problem Note: If the type/model and FRU information is not listed here, refer to FFC 221.	
-----	-----	--	---	--

Failing function code 823

Standard mouse adapter problem.

Use the following table to determine the part number for the field replaceable unit (FRU):

CCIN or FFC	Type and model	Part number	Description	Location code
823	Any		Standard mouse adapter problem Note: If the type/model and FRU information is not listed here, refer to FFC 221.	

Failing function code 824

Standard tablet adapter problem.

Use the following table to determine the part number for the field replaceable unit (FRU):

CCIN or FFC	Type and model	Part number	Description	Location code
	Any		Standard tablet adapter problem Note: For type/model and FRU information, if not listed here, refer to FFC 221.	

Failing function code 825

The NIO planar might be failing.

Use the following table to determine the part number for the field replaceable unit (FRU):

CCIN or FFC	Type and model	Part number	Description	Location code
825	Any	11K0571	NIO planar, 9076/POWER3 SMP High Node	

Failing function code 826

System port 1 adapter problem.

Use the following table to determine the part number for the field replaceable unit (FRU):

CCIN or FFC	Type and model	Part number	Description	Location code
826	Any		System port 1 adapter problem Note: If the type/model and FRU information is not listed here, refer to FFC 221.	

Failing function code 827

Built-in parallel port adapter problem.

Use the following table to determine the part number for the field replaceable unit (FRU):

CCIN or FFC	Type and model	Part number	Description	Location code
827	Any		Built-in parallel port adapter problem Note: If the type/model and FRU information is not listed here, refer to FFC 221.	

Failing function code 828

Standard diskette adapter problem.

Use the following table to determine the part number for the field replaceable unit (FRU):

CCIN or FFC	Type and model	Part number	Description	Location code
	Any		Standard diskette adapter problem Note: If the type/model and FRU information is not listed here, refer to FFC 221.	

Failing function code 82C

The graphics adapter might be failing.

Use the following table to determine the part number for the field replaceable unit (FRU):

CCIN or FFC	Type and model	Part number	Description	Location code
82C	Any	11H6095	S15 graphics PCI adapter	

Failing function code 830

The 8-port ISA adapter might be failing.

Use the following table to determine the part number for the field replaceable unit (FRU):

CCIN or FFC	Type and model	Part number	Description	Location code
830	Any	11H5969	8-Port ISA adapter	

Failing function code 831

System port 2 adapter problem.

Use the following table to determine the part number for the field replaceable unit (FRU):

CCIN or FFC	Type and model	Part number	Description	Location code
	Any		System port 2 adapter problem Note: If the type/model and FRU information is not listed here, refer to FFC 221.	

Failing function code 836

The 128-port async controller might be failing.

Use the following table to determine the part number for the field replaceable unit (FRU):

CCIN or FFC	Type and model	Part number	Description	Location code
836	Any	73H3384	128-port async controller	

Failing function code 837

The remote async node might be failing.

Use the following table to determine the part number for the field replaceable unit (FRU):

CCIN or FFC	Type and model	Part number	Description	Location code
837	Any	88G3842	Remote async node, 16-port EIA-232 enhanced remote async node	
837	Any	93H6549	Remote async node, 16-port EIA-232 rack mounted node	
837	Any	40H2589;	Remote async node, 16-port EIA-232 power supply	
837	Any	80P3869	Remote async node	

Failing function code 840

The PCI single-ended Ultra SCSI adapter might be failing.

Use the following table to determine the part number for the field replaceable unit (FRU):

CCIN or FFC	Type and model	Part number	Description	Location code
840	Any	93H3809	PCI single-ended ultra SCSI adapter Note: If you receive this FFC but are working with integrated ultra SCSI, see FFC 84A.	

Failing function code 844

The SCSI subsystem controller might be failing.

Use the following table to determine the part number for the field replaceable unit (FRU):

CCIN or FFC	Type and model	Part number	Description	Location code
844	Any		RAIDiant array SCSI subsystem controller Note: Refer to the 7135 documentation.	

Failing function code 845

The SCSI 2.0 GB disk drive might be failing.

Use the following table to determine the part number for the field replaceable unit (FRU):

CCIN or FFC	Type and model	Part number	Description	Location code
845	Any		RAIDiant array SCSI 2.0 GB disk drive Note: Refer to the 7135 documentation.	

Failing function code 846

The SCSI 1.3 GB disk drive might be failing.

Use the following table to determine the part number for the field replaceable unit (FRU):

CCIN or FFC	Type and model	Part number	Description	Location code
846	Any		RAIDiant array SCSI 1.3 GB disk drive Note: Refer to the 7135 documentation.	

Failing function code 84A

The backplane might be failing.

Use the following table to determine the part number for the field replaceable unit (FRU):

CCIN or FFC	Type and model	Part number	Description	Location code
84A	8203-E4A, 9407-M15, 9408-M25	42R7898	System backplane	Un-P1
84A	8204-E8A, 9409-M50	10N9369	System backplane	Un-P1
84A	9117-MMA	42R7352	I/O backplane	

Failing function code 868

Integrated SCSI I/O controller problem.

Use the following table to determine the part number for the field replaceable unit (FRU):

CCIN or FFC	Type and model	Part number	Description	Location code
868	Any		Integrated SCSI I/O controller problem Note: If the type/model and FRU information is not listed here, refer to FFC 221.	

Failing function code 887

The system backplane might be failing.

Use the following table to determine the part number for the field replaceable unit (FRU):

CCIN or FFC	Type and model	Part number	Description	Location code
887	8203-E4A, 9407-M15, 9408-M25	42R7898	System backplane	Un-P1
887	8204-E8A, 9409-M50	10N9369	System backplane	Un-P1
887	9117-MMA	03N6902	Integrated Ethernet adapter problem, system backplane	

Failing function code 891

The SCSI adapter might be failing.

Use the following table to determine the part number for the field replaceable unit (FRU):

CCIN or FFC	Type and model	Part number	Description	Location code
891	Any		Vendor SCSI adapter	

Failing function code 892

The display adapter might be failing.

Use the following table to determine the part number for the field replaceable unit (FRU):

CCIN or FFC	Type and model	Part number	Description	Location code
892	Any		Vendor display adapter	

Failing function code 893

The LAN adapter might be failing.

Use the following table to determine the part number for the field replaceable unit (FRU):

CCIN or FFC	Type and model	Part number	Description	Location code
893	Any		Vendor LAN adapter	

Failing function code 894

The async communications adapter might be failing.

Use the following table to determine the part number for the field replaceable unit (FRU):

CCIN or FFC	Type and model	Part number	Description	Location code
894	Any		Vendor async Communications adapter	

Failing function code 899

Atape problem.

Use the following table to determine the part number for the field replaceable unit (FRU):

CCIN or FFC	Type and model	Part number	Description	Location code
899	Any		Atape	

Failing function code 89C

The CD-ROM drive might be failing.

Use the following table to determine the part number for the field replaceable unit (FRU):

CCIN or FFC	Type and model	Part number	Description	Location code
89C	Any	73H1513	600 MB Double Speed Tray-Loading CD-ROM Note: The 2x CD-ROM drive is no longer available. A 4x CD-ROM drive will be shipped as a replacement.	

Failing function code 900

The graphics adapter might be failing.

Use the following table to determine the part number for the field replaceable unit (FRU):

CCIN or FFC	Type and model	Part number	Description	Location code
900;	Any	93H7983	GXT110P Graphics Adapter	

Failing function code 901

The SCSI device might be failing.

Use the following table to determine the part number for the field replaceable unit (FRU):

CCIN or FFC	Type and model	Part number	Description	Location code
901	Any		Vendor SCSI device	

Failing function code 902

The display might be failing.

Use the following table to determine the part number for the field replaceable unit (FRU):

CCIN or FFC	Type and model	Part number	Description	Location code
902	Any		Vendor display	

Failing function code 903

The async device might be failing.

Use the following table to determine the part number for the field replaceable unit (FRU):

CCIN or FFC	Type and model	Part number	Description	Location code
903	Any		Vendor async device	

Failing function code 904

The parallel device might be failing.

Use the following table to determine the part number for the field replaceable unit (FRU):

CCIN or FFC	Type and model	Part number	Description	Location code
904	Any		Vendor parallel device	

Failing function code 905

The device might be failing.

Use the following table to determine the part number for the field replaceable unit (FRU):

CCIN or FFC	Type and model	Part number	Description	Location code
-------------	----------------	-------------	-------------	---------------

905	Any		Other vendor device	
-----	-----	--	---------------------	--

Failing function code 908

The graphics accelerator attachment adapter might be failing.

Use the following table to determine the part number for the field replaceable unit (FRU):

CCIN or FFC	Type and model	Part number	Description	Location code
908	Any	93H2399	POWER GXT1000™ Graphics Accelerator Attachment Adapter	

Failing function code 912

The 2.0 GB SCSI-2 DE disk drive might be failing.

Use the following table to determine the part number for the field replaceable unit (FRU):

CCIN or FFC	Type and model	Part number	Description	Location code
912	Any	86F0119	2.0 GB SCSI-2 DE disk drive	

912	Any	86F0125	Differential frame electronics Attention: Check RETAIN® for frame electronics availability. Exchange the complete drive assembly whenever possible. Exchange the logic card only when the data on the disk must be saved.	
-----	-----	---------	---	--

Failing function code 913

The 1 GB DE disk drive might be failing.

Use the following table to determine the part number for the field replaceable unit (FRU):

CCIN or FFC	Type and model	Part number	Description	Location code
913	Any	6374682	1 GB DE disk drive, half-height	

913	Any	6374683	Differential frame electronics Attention: Check RETAIN® for frame electronics availability. Exchange the complete drive assembly whenever possible. Exchange the logic card only when the data on the disk must be saved.	
-----	-----	---------	---	--

Failing function code 914

The 5 GB 8 mm SCSI DE tape drive might be failing.

Use the following table to determine the part number for the field replaceable unit (FRU):

CCIN or FFC	Type and model	Part number	Description	Location code
914	Any	16G8492	5 GB 8 mm SCSI DE tape drive	

Failing function code 915

The 4/8 GB 4 mm tape drive might be failing.

Use the following table to determine the part number for the field replaceable unit (FRU):

CCIN or FFC	Type and model	Part number	Description	Location code
915	Any	59H3481	4/8 GB 4 mm tape drive	

Failing function code 917

The 2.0 GB DE F/W disk drive might be failing.

Use the following table to determine the part number for the field replaceable unit (FRU):

CCIN or FFC	Type and model	Part number	Description	Location code
917	Any	86F0767	2.0 GB DE F/W disk drive Note: If the disk drive is in a 7134 drawer, replace with FRU P/N 67G3022.	

Failing function code 918

The 2.0 GB 16-bit SCSI SE F/W disk drive might be failing.

Use the following table to determine the part number for the field replaceable unit (FRU):

CCIN or FFC	Type and model	Part number	Description	Location code
-------------	----------------	-------------	-------------	---------------

918	Any	86F0766	2.0 GB 16-bit SCSI SE F/W disk drive	
-----	-----	---------	--------------------------------------	--

Failing function code 921

The keyboard might be failing.

Use the following table to determine the part number for the field replaceable unit (FRU):

CCIN or FFC	Type and model	Part number	Description	Location code
921	Any	1392090	101 key keyboard;	
921	Any	1394609	101 key keyboard;	

Failing function code 922

The keyboard might be failing.

Use the following table to determine the part number for the field replaceable unit (FRU):

CCIN or FFC	Type and model	Part number	Description	Location code
922	Any	8131596	102 key keyboard problem keyboard, Arabic	
922	Any	93H8125	Keyboard, Arabic (ID 238)	
922	Any	93H8127	Keyboard, Belgium-French (ID 120)	
922	Any	1391414	Keyboard, Belgium-Dutch	
922	Any	1391526	Keyboard, Belgium-French	
922	Any	93H8126	Keyboard, Belgium-French	
922	Any	64F7707	Keyboard, Brazilian Portuguese	
922	Any	93H8124	Keyboard, Brazilian Portuguese (ID 275)	
922	Any	1399583	Keyboard, Bulgarian	
922	Any	93H8128	Keyboard, Bulgarian (ID 442)	
922	Any	93H8155	Keyboard, Chinese/US (ID 467)	
922	Any	1399570	Keyboard, Czechoslovakian	
922	Any	93H8129	Keyboard, Czechoslovakian (ID 243)	
922	Any	1391407	Keyboard, Danish	
922	Any	93H8130	Keyboard, Danish (ID 159)	

922	Any	93H8131	Keyboard, Dutch (ID 143)	
922	Any	1391511	Keyboard, Dutch/Netherlands	
922	Any	1391411	Keyboard, Finnish/Swedish	
922	Any	1391402	Keyboard, French	
922	Any	93H8132	Keyboard, French(ID 189)	
922	Any	82G3279	Keyboard, French-Canadian	
922	Any	93H8121	Keyboard, French-Canadian (ID 058)	
922	9117-MMA	93H8122	Keyboard, French-Canadian (ID 445)	
922	Any	93H8133	Keyboard, German (ID 129)	
922	Any	1391403	Keyboard, German/Austrian	
922	Any	1399046	Keyboard, Greek	
922	Any	93H8134	Keyboard, Greek (ID 129)	
922	Any	93H8135	Keyboard, Hebrew (ID 212)	
922	Any	1399581	Keyboard, Hungarian	
922	Any	93H8136	Keyboard, Hungarian (ID 208)	
922	Any	1391407	102 key keyboard problem Keyboard, Icelandic	
922	Any	93H8137	Keyboard, Icelandic (ID 197)	
922	Any	1393395	Keyboard, Italian	
922	Any	93H8138	Keyboard, Italian (ID 142)	
922	Any	93H8156	Keyboard, Korea (ID 413)	
922	Any	82G3292	Keyboard, Latin American (Spanish)	
922	Any	93H8152	Keyboard, Latvia (ID 234)x	
922	Any	1391409	Keyboard, Norwegian	
922	Any	93H8139	Keyboard, Norwegian (ID 155)	
922	Any	1391410	Keyboard, Portuguese	
922	Any	1399580	Keyboard, Polish	

922	Any	93H8140	Keyboard, Polish (ID 214)	
922	Any	93H8141	Keyboard, Portuguese (ID 163)	
922	Any	1399582	Keyboard, Romania	
922	Any	93H8142	Keyboard, Romania (ID 446)	
922	Any	1399579	Keyboard, Russian	
922	Any	93H8143	Keyboard, Russian (ID 443)	
922	Any	93H8144	Keyboard, Serbian (ID 118)	
922	Any	1399571	Keyboard, Slovak	
922	Any	93H8145	Keyboard, Slovak (ID 245)	
922	Any	1391405	Keyboard, Spanish	
922	Any	93H8123	Keyboard, Spanish (ID 171)	
922	Any	93H8146	Keyboard, Spanish (ID 172)	
922	Any	93H8147	Keyboard, Sweden/Finland (ID 153)	
922	Any	1395881	Keyboard, Swiss-French	
922	Any	93H8148	Keyboard, Swiss French/German (ID 150)	
922	Any	1395882	Keyboard, Swiss-German	
922	Any	93H8157	Keyboard, Thailand (ID 191)	
922	Any	1393286	Keyboard, Turkish (ID 179)	
922	Any	93H8149	Keyboard, Turkish (ID 179)	
922	Any	8125409	Keyboard, Turkish (ID 440)	
922	Any	93H8150	Keyboard, Turkish (ID 440)	
922	Any	1391406	Keyboard, U.K. English	
922	Any	93H8151	Keyboard, Turkish (ID 166)	
922	Any	93H8153	Keyboard, US English ISO9995 (ID 103P)	
922	Any	06H3048	Keyboard, U.S. OEM	
922	Any	93H8154	Keyboard, 106 Japan (ID 194)	

Failing function code 923

The keyboard might be failing.

Use the following table to determine the part number for the field replaceable unit (FRU):

CCIN or FFC	Type and model	Part number	Description	Location code
923	Any	1392090	106 keys International keyboard problem keyboard, Chinese	
923	Any	79F0167	106 keys International keyboard problem keyboard, Japanese-Kanji	
923	Any	66G0507	106 keys International keyboard problem Japanese, Enhanced	
923	Any	06H5286	106 keys International keyboard problem keyboard, Korean	
923	Any	02G7353	106 keys International keyboard problem keyboard, Taiwanese	

Failing function code 925

The mouse might be failing.

Use the following table to determine the part number for the field replaceable unit (FRU):

CCIN or FFC	Type and model	Part number	Description	Location code
925	Any	93H9113	3-button mouse	
925	Any	76H5084	3-button mouse	

Failing function code 926

The tablet might be failing.

Use the following table to determine the part number for the field replaceable unit (FRU):

CCIN or FFC	Type and model	Part number	Description	Location code
926	Any	6247450	Tablet, 5083 model 21	
926	Any	74F3130	Tablet, 6093 model 11	

Failing function code 927

The tablet might be failing.

Use the following table to determine the part number for the field replaceable unit (FRU):

CCIN or FFC	Type and model	Part number	Description	Location code
927	Any	6247452	Tablet, 5083 model 22	
927	Any	74F3140	Tablet, 6093 model 12	
927	Any	93H7714	Tablet, 6093 model 21	

Failing function code 929

The cable might be failing.

Use the following table to determine the part number for the field replaceable unit (FRU):

CCIN or FFC	Type and model	Part number	Description	Location code
929	Any	39F8227	Dials, 6094 model 10 cable, serial attachment, power	
929	Any	39F8302	Dials, 6094 model 10 cable, serial attachment, power	

Failing function code 930

The keyboard might be failing.

Use the following table to determine the part number for the field replaceable unit (FRU):

CCIN or FFC	Type and model	Part number	Description	Location code
930	Any	39F8226	Lighted program function keyboard (LPFK), 6094 model 20	
930	Any	39F8302	Cable, serial attachment, power	

Failing function code 935

The diskette drive might be failing.

Use the following table to determine the part number for the field replaceable unit (FRU):

CCIN or FFC	Type and model	Part number	Description	Location code
935	Any	93F2361	1.44 MB 3.5-inch white diskette drive	
935	Any	76H4091	1.44 MB 3.5-inch black diskette drive	
935	Any	07L7814	1.44 MB 3.5-inch diskette drive	

Failing function code 938

The adapter might be failing.

Use the following table to determine the part number for the field replaceable unit (FRU):

CCIN or FFC	Type and model	Part number	Description	Location code
	Any		Serial HIPPI PCI adapter Notes: 1. Use the number printed above the bar code to order this part. 2. The FRU part number of the wrap plug used with this adapter is 21H3547.	

Failing function code 946

Standard system port 3 adapter problem.

Use the following table to determine the part number for the field replaceable unit (FRU):

CCIN or FFC	Type and model	Part number	Description	Location code
946	9117-MMA	39J0780	Standard system port 3 adapter problem, passthru card	
946	9117-MMA	10N8752	Standard system port 3 adapter problem, I/O backplane	

Failing function code 947

The 1000 MB 16-bit disk drive might be failing.

Use the following table to determine the part number for the field replaceable unit (FRU):

CCIN or FFC	Type and model	Part number	Description	Location code
947	Any	84G3491	1000 MB, 16-bit disk drive	

Failing function code 950

Unknown SCSI device is missing.

Use the following table to determine the part number for the field replaceable unit (FRU):

CCIN or FFC	Type and model	Part number	Description	Location code
950	Any		Unknown SCSI device is missing.	

Failing function code 951

The 670 MB SCSI disk drive might be failing.

Use the following table to determine the part number for the field replaceable unit (FRU):

CCIN or FFC	Type and model	Part number	Description	Location code
951	Any	53F3429	670 MB SCSI Disk Drive	
951	Any	6373521	Disk drive logic Card	

Failing function code 952

The 355 MB SCSI disk drive might be failing.

Use the following table to determine the part number for the field replaceable unit (FRU):

CCIN or FFC	Type and model	Part number	Description	Location code
952	Any	53F3427	355 MB SCSI disk drive Note: Exchange the complete drive whenever possible. If extreme data saving measures are necessary, exchange the logic card.	
952	Any	6373521	Logic card Note: Exchange the complete drive whenever possible. If extreme data saving measures are necessary, exchange the logic card.	

Failing function code 953

The 320 MB SCSI disk drive might be failing.

Use the following table to determine the part number for the field replaceable unit (FRU):

CCIN or FFC	Type and model	Part number	Description	Location code
953	Any	93X0961	320 MB SCSI disk drive Note: Exchange the complete drive whenever possible. Exchange the logic card only when the data on the disk must be saved.	

953	Any	93X0901	Logic card and frame assembly Note: Exchange the complete drive whenever possible. Exchange the logic card only when the data on the disk must be saved.	
-----	-----	---------	--	--

Failing function code 954

The 400 MB SCSI disk drive might be failing.

Use the following table to determine the part number for the field replaceable unit (FRU):

CCIN or FFC	Type and model	Part number	Description	Location code
954	Any	00G1948	400 MB SCSI disk drive Note: Exchange the complete drive whenever possible. Exchange the logic card only when the data on the disk must be saved.	
954	Any	73F8994	Logic card and frame assembly Note: Exchange the complete drive whenever possible. Exchange the logic card only when the data on the disk must be saved.	

Failing function code 955

The 857 MB SCSI disk drive might be failing.

Use the following table to determine the part number for the field replaceable unit (FRU):

CCIN or FFC	Type and model	Part number	Description	Location code
955	Any	45G9502	857 MB SCSI disk drive	

Failing function code 956

The 355/670 MB logic card might be failing.

Use the following table to determine the part number for the field replaceable unit (FRU):

CCIN or FFC	Type and model	Part number	Description	Location code
-------------	----------------	-------------	-------------	---------------

956	Any	6373521	355/670 MB logic card	
-----	-----	---------	-----------------------	--

Failing function code 959

The 160 MB SCSI disk drive might be failing.

Use the following table to determine the part number for the field replaceable unit (FRU):

CCIN or FFC	Type and model	Part number	Description	Location code
959	Any	81F8085	160MB SCSI disk drive	

Failing function code 960

The 1.37 GB SCSI disk drive assembly might be failing.

Use the following table to determine the part number for the field replaceable unit (FRU):

CCIN or FFC	Type and model	Part number	Description	Location code
960	Any	52G0061	1.37 GB SCSI disk drive assembly Note: Logic card stocking is limited; special ordering is required. Check RETAIN® for logic card availability. Exchange the complete drive assembly when possible. Exchange the logic card when the data on the disk must be saved.	
960	Any	31G9756	logic card Note: Logic card stocking is limited; special ordering is required. Check RETAIN for logic card availability. Exchange the complete drive assembly when possible. Exchange the logic card when the data on the disk must be saved.	

Failing function code 962

The machine type 3161 device might be failing.

Use the following table to determine the part number for the field replaceable unit (FRU):

CCIN or FFC	Type and model	Part number	Description	Location code
962	Any		A machine type 3161 device is attached, use device documentation.	

Failing function code 963

The machine type 3163 device might be failing.

Use the following table to determine the part number for the field replaceable unit (FRU):

CCIN or FFC	Type and model	Part number	Description	Location code
963	Any		A machine type 3163 device is attached, use device documentation.	

Failing function code 964

The tape drive might be failing.

Use the following table to determine the part number for the field replaceable unit (FRU):

CCIN or FFC	Type and model	Part number	Description	Location code
964	Any	59H2839	20 GB 8 mm SE SCSI tape drive (internal,white)	
964	Any	59H4120	20 GB 8 mm SE SCSI tape drive (internal, black)	
964	Any	59H2835	20 GB 8 mm Diff SCSI tape drive (external/white)	
964	Any	59H2842	400 GB 8 mm Diff tape autoloader (No LCD in bezel/ white)	

Failing function code 966

The audio/video decoder adapter might be failing.

Use the following table to determine the part number for the field replaceable unit (FRU):

CCIN or FFC	Type and model	Part number	Description	Location code
966	Any	93H2136	MediaStreamer [®] audio/video decoder adapter	

Failing function code 968

The 1 GB SCSI SE disk drive might be failing.

Use the following table to determine the part number for the field replaceable unit (FRU):

CCIN or FFC	Type and model	Part number	Description	Location code
968	Any	55F9902	1 GB SCSI SE disk drive Note: Check RETAIN for frame logic card availability. Exchange the complete drive assembly when possible. Exchange the logic card when the data on the disk must be saved.	
968	Any	55F9909	single-ended frame electronics Note: Check RETAIN for frame logic card availability. Exchange the complete drive assembly when possible. Exchange the logic card when the data on the disk must be saved.	

Failing function code 970

The 1/2-inch 9-track tape drive might be failing.

Use the following table to determine the part number for the field replaceable unit (FRU):

CCIN or FFC	Type and model	Part number	Description	Location code
970	Any		1/2-inch 9-track tape drive, use device documentation	

Failing function code 971

The 150 MB 1/4 inch tape drive might be failing.

Use the following table to determine the part number for the field replaceable unit (FRU):

CCIN or FFC	Type and model	Part number	Description	Location code
971	Any	16G8423	150 MB 1/4 inch tape drive	

Failing function code 972

The 2.3 GB 8 mm tape drive might be failing.

Use the following table to determine the part number for the field replaceable unit (FRU):

CCIN or FFC	Type and model	Part number	Description	Location code
-------------	----------------	-------------	-------------	---------------

972	Any	16G8421	2.3 GB 8 mm tape drive	
-----	-----	---------	------------------------	--

Failing function code 973

The SCSI tape drive might be failing.

Use the following table to determine the part number for the field replaceable unit (FRU):

CCIN or FFC	Type and model	Part number	Description	Location code
973	Any		Other SCSI tape drive	

Failing function code 974

The CD-ROM drive might be failing.

Use the following table to determine the part number for the field replaceable unit (FRU):

CCIN or FFC	Type and model	Part number	Description	Location code
974	Any	88G3929	CD-ROM drive (Type A or Type B bezel)	

Failing function code 980

The machine type 4216 device might be failing.

Use the following table to determine the part number for the field replaceable unit (FRU):

CCIN or FFC	Type and model	Part number	Description	Location code
980	Any		Machine type 4216, use device documentation	

Failing function code 981

The 540 MB SCSI-2 Single-Ended disk drive might be failing.

Use the following table to determine the part number for the field replaceable unit (FRU):

CCIN or FFC	Type and model	Part number	Description	Location code
981	Any	51G8237	540 MB SCSI-2 Single-Ended Disk Drive	

Failing function code 982

The machine type 3852 device might be failing.

Use the following table to determine the part number for the field replaceable unit (FRU):

CCIN or FFC	Type and model	Part number	Description	Location code
-------------	----------------	-------------	-------------	---------------

982	Any		Machine type 3852, use device documentation	
-----	-----	--	---	--

Failing function code 983

The machine type 4201 device might be failing.

Use the following table to determine the part number for the field replaceable unit (FRU):

CCIN or FFC	Type and model	Part number	Description	Location code
983	Any		Machine type 4201, use device documentation	

Failing function code 984

The 1 GB 8-bit disk drive might be failing.

Use the following table to determine the part number for the field replaceable unit (FRU):

CCIN or FFC	Type and model	Part number	Description	Location code
984	Any	45G9467	1 GB 8-bit disk drive	

Failing function code 986

The 2.4 GB SCSI disk drive might be failing.

Use the following table to determine the part number for the field replaceable unit (FRU):

CCIN or FFC	Type and model	Part number	Description	Location code
986	Any	36G0454	2.4 GB SCSI Disk Drive	

Failing function code 987

The 600 MB CD-ROM-2 disk drive might be failing.

Use the following table to determine the part number for the field replaceable unit (FRU):

CCIN or FFC	Type and model	Part number	Description	Location code
987	Any	73H1513	600 MB CD-ROM-2 Disk Drive	

Failing function code 989

The 200 MB SCSI disk drive might be failing.

Use the following table to determine the part number for the field replaceable unit (FRU):

CCIN or FFC	Type and model	Part number	Description	Location code
989	Any	43G1842	200 MB SCSI Disk Drive	

Failing function code 990

The 2.0 GB SCSI-2 SE disk drive might be failing.

Use the following table to determine the part number for the field replaceable unit (FRU):

CCIN or FFC	Type and model	Part number	Description	Location code
990	Any	86F0118	2.0 GB SCSI-2 SE Disk Drive	

Failing function code 991

The 525 MB 1/4-inch SCSI tape drive might be failing.

Use the following table to determine the part number for the field replaceable unit (FRU):

CCIN or FFC	Type and model	Part number	Description	Location code
991	Any	46G2700	525 MB 1/4-Inch SCSI Tape Drive	

Failing function code 992

The machine type 5202 might be failing.

Use the following table to determine the part number for the field replaceable unit (FRU):

CCIN or FFC	Type and model	Part number	Description	Location code
992	5202		Use the service documentation for the 5202	

Failing function code 993

The machine type 5204 might be failing.

Use the following table to determine the part number for the field replaceable unit (FRU):

CCIN or FFC	Type and model	Part number	Description	Location code
993	5204		Use the service documentation for the 5204	

Failing function code 994

The 5/10 GB 8 mm internal tape drive might be failing.

Use the following table to determine the part number for the field replaceable unit (FRU):

CCIN or FFC	Type and model	Part number	Description	Location code
994	5202	59H3159	5/10 GB 8 mm Internal Tape Drive	

Failing function code 995

The 1.2 GB 1/4 inch cartridge tape drive might be failing.

Use the following table to determine the part number for the field replaceable unit (FRU):

CCIN or FFC	Type and model	Part number	Description	Location code
995	Any	21H5155	1.2 GB 1/4 inch cartridge tape drive	

Failing function code 998

The 2.0 GB 4 mm SCSI tape drive might be failing.

Use the following table to determine the part number for the field replaceable unit (FRU):

CCIN or FFC	Type and model	Part number	Description	Location code
998	Any	8191193	2.0 GB 4 mm SCSI tape drive	

Failing function code 999

The machine type 3514, 7137 disk array subsystems might be failing.

Use the following table to determine the part number for the field replaceable unit (FRU):

CCIN or FFC	Type and model	Part number	Description	Location code
999	Any		Machine type 3514, 7137 Disk array subsystems Note: Refer to the 3514 or 7137 documentation	

Failing function code B08

The ethernet 10 base twisted-pair transceiver might be failing.

Use the following table to determine the part number for the field replaceable unit (FRU):

CCIN or FFC	Type and model	Part number	Description	Location code
B08	Any	02G7431	Ethernet 10 base twisted-pair transceiver	

Failing function code B09

The ethernet/ISO 8802.3 transceiver might be failing.

Use the following table to determine the part number for the field replaceable unit (FRU):

CCIN or FFC	Type and model	Part number	Description	Location code
B09	Any	02G7437	Ethernet/ISO 8802.3 transceiver (formerly IEEE 802.3)	

Failing function code B10

Thermal fuse problem.

Use the following table to determine the part number for the field replaceable unit (FRU):

CCIN or FFC	Type and model	Part number	Description	Location code
B10	Any	03N6902	System board PTC (thermal fuse) Note: If a thermal fuse has opened, it should reset within ten minutes after turning the power off. If the thermal fuse does not reset, a faulty device may be drawing excessive power through the fuse.	

Failing function code B31

Unknown keyboard type.

Use the following table to determine the part number for the field replaceable unit (FRU):

CCIN or FFC	Type and model	Part number	Description	Location code
B31	Any		Unknown keyboard type	

Failing function code B3A

Unidentifiable backplane tied to a SCSI RAID adapter.

Use the following table to determine the part number for the field replaceable unit (FRU):

CCIN or FFC	Type and model	Part number	Description	Location code
B3A	Any		Unidentifiable backplane tied to a SCSI RAID adapter	

Failing function code B54

The 128-port async controller cable might be failing.

Use the following table to determine the part number for the field replaceable unit (FRU):

CCIN or FFC	Type and model	Part number	Description	Location code
B54	Any	43G0936	128-port async controller cable, 0.2m (9 in.)	
B54	Any	43G0937	128-port async controller cable, 4.6m (15 ft.)	

Failing function code B69

The coprocessor multiport adapter might be failing.

Use the following table to determine the part number for the field replaceable unit (FRU):

CCIN or FFC	Type and model	Part number	Description	Location code
B69	Any	33F8967	Coprocessor multiport adapter, model 2 (0 MB)	

Failing function code B71

The 8-port EIA-232-D multiport model 2 interface card might be failing.

Use the following table to determine the part number for the field replaceable unit (FRU):

CCIN or FFC	Type and model	Part number	Description	Location code
B71	Any	53F2612	8-Port EIA-232-D multiport, model 2 interface card	

Failing function code B72

The 8-port EIA-422-A multiport model 2 interface card might be failing.

Use the following table to determine the part number for the field replaceable unit (FRU):

CCIN or FFC	Type and model	Part number	Description	Location code
B72	Any	53F2615	8-Port EIA-422-A multiport, model 2 interface card	

Failing function code B73

The 6-port V.35 multiport model 2 interface card might be failing.

Use the following table to determine the part number for the field replaceable unit (FRU):

CCIN or FFC	Type and model	Part number	Description	Location code
B73	Any	72F0164	6-port V.35 multiport, model 2 interface card	

Failing function code B74

The 6-port V.21 multiport model 2 interface card might be failing.

Use the following table to determine the part number for the field replaceable unit (FRU):

CCIN or FFC	Type and model	Part number	Description	Location code
-------------	----------------	-------------	-------------	---------------

B74	Any	04G5500	6-Port V.21 multiport, model 2 interface card	
-----	-----	---------	---	--

Failing function code B77

The coprocessor 1 MB memory module might be failing.

Use the following table to determine the part number for the field replaceable unit (FRU):

CCIN or FFC	Type and model	Part number	Description	Location code
B77	Any	53F2662	Coprocessor 1 MB memory module	

Failing function code B81

The coprocessor multiport interface cable might be failing.

Use the following table to determine the part number for the field replaceable unit (FRU):

CCIN or FFC	Type and model	Part number	Description	Location code
B81	Any	40F9897	Coprocessor multiport interface cable	

Failing function code B82

The coprocessor multiport V.35 cable might be failing.

Use the following table to determine the part number for the field replaceable unit (FRU):

CCIN or FFC	Type and model	Part number	Description	Location code
B82	Any	71F0162	Coprocessor multiport V.35 cable	

Failing function code B83

The problem is a PCI 64-bit fibre channel adapter.

The FRU part number is 80P4384.

Use the following table to determine the part number for the field replaceable unit (FRU):

CCIN or FFC	Type and model	Part number	Description	Location code
B83	Any	71F0164	Coprocessor multiport X.21 cable	

Failing function code B88

The SCSI I/O controller might be failing.

Use the following table to determine the part number for the field replaceable unit (FRU):

CCIN or FFC	Type and model	Part number	Description	Location code
-------------	----------------	-------------	-------------	---------------

B88	Any		<p>Generic SCSI I/O controller</p> <p>Notes:</p> <ol style="list-style-type: none"> 1. If the failing FRU for this FFC is PCI(x), where x is the PCI bus number, 0, 1, ..., refer to FFC 221. 2. Use the location code to identify the failing FRU. Determine if the failing FRU is integrated on the system board. If the failing FRU is integrated use FFC 221. If the failing FRU is not integrated replace the FRU identified by its description that is shown with the location code for SCSI and SCSI-2 adapter. Choose the FFC for the appropriate SCSI I/O controller. 3. Check the SCSI controller fuse or PTC resistor before exchanging the system board. Refer to SCSI-2 Single-Ended Adapter PTC Failure Isolation Procedure in SCSI service hints. 4. Check that the SCSI disable jumper is in the enabled position. 5. Check the FRU number of the installed external terminator: Low density - 51G7736 High density - 51G7737 	
-----	-----	--	---	--

Failing function code C11

The 2.4 GB SCSI disk drive assembly might be failing.

Use the following table to determine the part number for the field replaceable unit (FRU):

CCIN or FFC	Type and model	Part number	Description	Location code
C11	Any	36G4280	2.4 GB SCSI disk drive field repair assembly Note: The field repair assembly includes one disk drive, the electronics planar, and the 5-1/4 inch form factor cage. The remaining good drive is removed from the failed disk drive assembly and installed in the field repair assembly to create a complete dual-disk drive assembly. If saving data is critical, try installing the faulty drive in place of one of the two good drives in the now-complete field repair assembly. If the faulty drive operates satisfactorily, the problem was probably in the electronics planar.	

Failing function code C22

The RJ-45 to DB25 converter cable might be failing.

Use the following table to determine the part number for the field replaceable unit (FRU):

CCIN or FFC	Type and model	Part number	Description	Location code
C22	Any	94H0779	RJ-45 to DB25 converter cable kit	

Failing function code C24

The fiber optic cable for the PCI fibre channel adapter might be failing.

Use the following table to determine the part number for the field replaceable unit (FRU):

CCIN or FFC	Type and model	Part number	Description	Location code
-------------	----------------	-------------	-------------	---------------

C24	Any	54G3384	Fiber optic cable for PCI Fibre Channel adapter (6.7 m)	
C24	Any	55G3384	Fiber optic cable for PCI Fibre Channel adapter (12.8 m)	

Failing function code C33

The GPSS card might be failing.

Use the following table to determine the part number for the field replaceable unit (FRU):

CCIN or FFC	Type and model	Part number	Description	Location code
C33	Any	73H4034	GPSS card	

Failing function code C34

The RSS card might be failing.

Use the following table to determine the part number for the field replaceable unit (FRU):

CCIN or FFC	Type and model	Part number	Description	Location code
C34	Any	11H8490	RSS card (without memory sockets)	

Failing function code C35

The VOO card might be failing.

Use the following table to determine the part number for the field replaceable unit (FRU):

CCIN or FFC	Type and model	Part number	Description	Location code
C35	Any	65G4887	VOO card	

Failing function code C36

The attachment adapter cable might be failing.

Use the following table to determine the part number for the field replaceable unit (FRU):

CCIN or FFC	Type and model	Part number	Description	Location code
C36	Any	65G4892	Attachment adapter cable	

Failing function code C44

The VOO/RSS crossover cable might be failing.

Use the following table to determine the part number for the field replaceable unit (FRU):

CCIN or FFC	Type and model	Part number	Description	Location code
-------------	----------------	-------------	-------------	---------------

C44	Any	65G4894	VOO/RSS crossover cable	
-----	-----	---------	-------------------------	--

Failing function code C45

The 12M VRAM memory module might be failing.

Use the following table to determine the part number for the field replaceable unit (FRU):

CCIN or FFC	Type and model	Part number	Description	Location code
C45	Any	65G4889	12M VRAM memory module	

Failing function code C46

The 16M VRAM memory module might be failing.

Use the following table to determine the part number for the field replaceable unit (FRU):

CCIN or FFC	Type and model	Part number	Description	Location code
C46	Any	65G4890	16M VRAM memory module	

Failing function code C47

The 16M DRAM memory module might be failing.

Use the following table to determine the part number for the field replaceable unit (FRU):

CCIN or FFC	Type and model	Part number	Description	Location code
C47	Any	65G4891	16M DRAM memory module	

Failing function code C48

The RSS/GPSS crossover card might be failing.

Use the following table to determine the part number for the field replaceable unit (FRU):

CCIN or FFC	Type and model	Part number	Description	Location code
C48	Any	65G4893	RSS/GPSS crossover card	

Failing function code C94

The 4 MB memory module might be failing.

Use the following table to determine the part number for the field replaceable unit (FRU):

CCIN or FFC	Type and model	Part number	Description	Location code
C94	Any	68X6356	IBM ARTIC960 4 MB memory module	

Failing function code C95

The 4-port selectable interface board might be failing.

Use the following table to determine the part number for the field replaceable unit (FRU):

CCIN or FFC	Type and model	Part number	Description	Location code
C95	Any	87H3413	IBM ARTIC960 4-port selectable interface board	
C95	Any	87H3428	IBM ARTIC960 4-port T1/E1 interface card	
C95	Any	87H3701	IBM ARTIC960Hx DSP interface card	
C95	Any	11K0790	IBM ARTIC960 quad T1/E1 interface card	
C95	Any	51H8702	IBM ARTIC960 PCI adapter interface board	

Failing function code C97

Wrap plug.

Use the following table to determine the part number for the field replaceable unit (FRU):

CCIN or FFC	Type and model	Part number	Description	Location code
C97	Any	87H3502	IBM ARTIC960 4-port T1/E1 interface card wrap plug Note: A wrap plug is shipped with each adapter and cable.	
C97	Any	87H3311	IBM ARTIC960 4-port selectable interface board wrap plug Note: A wrap plug is shipped with each adapter and cable.	
C97	Any	5605670	ESCON wrap plug Note: A wrap plug is shipped with each adapter and cable.	

Failing function code C98

The cable might be failing.

Use the following table to determine the part number for the field replaceable unit (FRU):

CCIN or FFC	Type and model	Part number	Description	Location code
-------------	----------------	-------------	-------------	---------------

C98	Any	87H3405	IBM ARTIC960 4-port selectable EIA-232 cable Note: A wrap plug is shipped with each adapter and cable.	
C98	Any	87H3396	IBM ARTIC960 4-port selectable RS-449 cable Note: A wrap plug is shipped with each adapter and cable.	
C98	Any	87H3408	IBM ARTIC960 4-port selectable X.21 cable Note: A wrap plug is shipped with each adapter and cable.	
C98	Any	87H3399	IBM ARTIC960 4-port selectable V.35 cable Note: A wrap plug is shipped with each adapter and cable.	
C98	Any	87H3402	IBM ARTIC960 4-port selectable EIA-530 cable Note: A wrap plug is shipped with each adapter and cable.	
C98	Any	87H3518	IBM ARTIC960 4-port T1 RJ-45 cable Note: A wrap plug is shipped with each adapter and cable.	
C98	Any	87H3515	IBM ARTIC960 4-port E1 RJ-45 cable Note: A wrap plug is shipped with each adapter and cable.	

Failing function code D01

L2 cache problem.

Use the following table to determine the part number for the field replaceable unit (FRU):

CCIN or FFC	Type and model	Part number	Description	Location code
D01	Any	10N9146	Generic L2 cache problem, 3.5 GHz POWER6, 2 Core Processor Card	

D01	Any	10N9144	Generic L2 cache problem, 4.2 GHz POWER6, 2 Core Processor Card	
D01	Any	10N9139	Generic L2 cache problem, 4.7 GHz POWER6, 2 Core Processor Card	

Failing function code D06

The 64 port to 128 port converter might be failing.

Use the following table to determine the part number for the field replaceable unit (FRU):

CCIN or FFC	Type and model	Part number	Description	Location code
D06	Any	88G3650	64 Port to 128 port converter kit (four to a pack) Note: Converter part number is 88G3651	

Failing function code D07

The processor card might be failing.

Use the following table to determine the part number for the field replaceable unit (FRU):

CCIN or FFC	Type and model	Part number	Description	Location code
D07	Any	10N9146	3.5 GHz POWER6, 2 Core Processor Card	
D07	9117-MMA	10N9144	4.2 GHz POWER6, 2 Core Processor Card	
D07	9117-MMA	10N9139	4.7 GHz POWER6, 2 Core Processor Card	

Failing function code D08

The fan assembly might be failing.

Use the following table to determine the part number for the field replaceable unit (FRU):

CCIN or FFC	Type and model	Part number	Description	Location code
D08	7134	88G5722	7134, DC Fan assembly	

Failing function code D46

The cable might be failing.

Use the following table to determine the part number for the field replaceable unit (FRU):

CCIN or FFC	Type and model	Part number	Description	Location code
-------------	----------------	-------------	-------------	---------------

D46	Any	6339098	Token-ring 9-pin D-shell cable, 3m (10 ft.)	
D46	Any	60G1063	Token-ring RJ-45 STP cable, 3m (10 ft.) Note: Not used with the high-speed token-ring PCI adapter	
D46	Any	93H8894	RJ-45 to 9-pin D-shell token-ring conversion cable Note: Not used with the high-speed token-ring PCI adapter	
D46	Any	OEM cable	Standard UTP RJ-45 cable	

Failing function code D50

See failing function code 190.

Use the following table to determine the part number for the field replaceable unit (FRU):

CCIN or FFC	Type and model	Part number	Description	Location code
D50	Any		See FFC 190	

Failing function code D56

The printer/terminal serial cable might be failing.

Use the following table to determine the part number for the field replaceable unit (FRU):

CCIN or FFC	Type and model	Part number	Description	Location code
D56	Any	10N6535	EIA-232E printer/terminal serial cable	

Failing function code D57

The 8-port multiport interface cable ISA async adapter might be failing.

Use the following table to determine the part number for the field replaceable unit (FRU):

CCIN or FFC	Type and model	Part number	Description	Location code
D57	Any	07L9822	8-Port multiport interface cable ISA async adapter	

Failing function code D59

The TP PCI ethernet adapter might be failing.

Use the following table to determine the part number for the field replaceable unit (FRU):

CCIN or FFC	Type and model	Part number	Description	Location code
D59	Any	93H7766	TP PCI Ethernet adapter	

Failing function code D60

The T2 PCI ethernet adapter might be failing.

Use the following table to determine the part number for the field replaceable unit (FRU):

CCIN or FFC	Type and model	Part number	Description	Location code
D60	Any	93H1902	T2 PCI Ethernet adapter	

Failing function code D66

The machine type 7250 RSS card might be failing.

Use the following table to determine the part number for the field replaceable unit (FRU):

CCIN or FFC	Type and model	Part number	Description	Location code
D66	Any	11H4436	Machine type 7250, RSS card (with memory sockets)	

Failing function code D67

The memory module might be failing.

Use the following table to determine the part number for the field replaceable unit (FRU):

CCIN or FFC	Type and model	Part number	Description	Location code
D67	Any	see system unit parts	8 MB, ECC, 50 nsec memory module	

Failing function code D68

The memory module might be failing.

Use the following table to determine the part number for the field replaceable unit (FRU):

CCIN or FFC	Type and model	Part number	Description	Location code
D68	Any	see system unit parts	16 MB, ECC, 50 nsec memory module	

Failing function code D69

The memory module might be failing.

Use the following table to determine the part number for the field replaceable unit (FRU):

CCIN or FFC	Type and model	Part number	Description	Location code
D69	Any	see system unit parts	32 MB, ECC, 50 nsec memory module	

Failing function code D70

The memory module might be failing.

Use the following table to determine the part number for the field replaceable unit (FRU):

CCIN or FFC	Type and model	Part number	Description	Location code
D70	Any	see system unit parts	64 MB, ECC, 50 nsec memory module	

Failing function code D71

The memory module might be failing.

Use the following table to determine the part number for the field replaceable unit (FRU):

CCIN or FFC	Type and model	Part number	Description	Location code
D71	Any	42H2771	8 MB, ECC, 60 nsec memory module	

Failing function code D72

The memory module might be failing.

Use the following table to determine the part number for the field replaceable unit (FRU):

CCIN or FFC	Type and model	Part number	Description	Location code
D72	Any	42H2772	16 MB, ECC, 60 nsec memory module	

Failing function code D73

The memory module might be failing.

Use the following table to determine the part number for the field replaceable unit (FRU):

CCIN or FFC	Type and model	Part number	Description	Location code
D73	Any	42H2773	32 MB, ECC, 60 nsec memory module	

Failing function code D74

The system memory might be failing.

Use the following table to determine the part number for the field replaceable unit (FRU):

CCIN or FFC	Type and model	Part number	Description	Location code
D74	Any		System memory, see the system unit service guide	

Failing function code D75

The memory module might be failing.

Use the following table to determine the part number for the field replaceable unit (FRU):

CCIN or FFC	Type and model	Part number	Description	Location code
D75	Any	See system unit parts	8 MB, ECC, 70 nsec memory module	

Failing function code D76

The memory module might be failing.

Use the following table to determine the part number for the field replaceable unit (FRU):

CCIN or FFC	Type and model	Part number	Description	Location code
D76	Any	See system unit parts	16 MB, ECC, 70 nsec memory module	

Failing function code D77

The memory module might be failing.

Use the following table to determine the part number for the field replaceable unit (FRU):

CCIN or FFC	Type and model	Part number	Description	Location code
d77	Any	See system unit parts	32 MB, ECC, 70 nsec memory module	

Failing function code D78

The memory module might be failing.

Use the following table to determine the part number for the field replaceable unit (FRU):

CCIN or FFC	Type and model	Part number	Description	Location code
D78	Any	See system unit parts	64 MB, ECC, 70 nsec memory module	

Failing function code D83

The memory module might be failing.

Use the following table to determine the part number for the field replaceable unit (FRU):

CCIN or FFC	Type and model	Part number	Description	Location code
D83	Any	See system unit parts	8 MB, parity, 50 nsec memory module	

Failing function code D84

The memory module might be failing.

Use the following table to determine the part number for the field replaceable unit (FRU):

CCIN or FFC	Type and model	Part number	Description	Location code
D84	Any	See system unit parts	16 MB, parity, 50 nsec memory module	

Failing function code D85

The memory module might be failing.

Use the following table to determine the part number for the field replaceable unit (FRU):

CCIN or FFC	Type and model	Part number	Description	Location code
D85	Any	See system unit parts	32 MB, parity, 50 nsec memory module	

Failing function code D86

The memory module might be failing.

Use the following table to determine the part number for the field replaceable unit (FRU):

CCIN or FFC	Type and model	Part number	Description	Location code
D86	Any	See system unit parts	64 MB, parity, 50 nsec memory module	

Failing function code D87

The memory module might be failing.

Use the following table to determine the part number for the field replaceable unit (FRU):

CCIN or FFC	Type and model	Part number	Description	Location code
D87	Any	See system unit parts	8 MB, parity, 60 nsec memory module	

Failing function code D88

The memory module might be failing.

Use the following table to determine the part number for the field replaceable unit (FRU):

CCIN or FFC	Type and model	Part number	Description	Location code
D88	Any	See system unit parts	16 MB, parity, 60 nsec memory module	

Failing function code D89

The memory module might be failing.

Use the following table to determine the part number for the field replaceable unit (FRU):

CCIN or FFC	Type and model	Part number	Description	Location code
D89	Any	See system unit parts	32 MB, parity, 60 nsec memory module	

Failing function code D90

The memory module might be failing.

Use the following table to determine the part number for the field replaceable unit (FRU):

CCIN or FFC	Type and model	Part number	Description	Location code
D90	Any	See system unit parts	64 MB, parity, 60 nsec memory module	

Failing function code D91

The memory module might be failing.

Use the following table to determine the part number for the field replaceable unit (FRU):

CCIN or FFC	Type and model	Part number	Description	Location code
D91	AnyA	See system unit parts	8 MB, parity, 70 nsec memory module	

Failing function code D92

The memory module might be failing.

Use the following table to determine the part number for the field replaceable unit (FRU):

CCIN or FFC	Type and model	Part number	Description	Location code
D92	Any	See system unit parts	16 MB, parity, 70 nsec memory module	

Failing function code D93

The memory module might be failing.

Use the following table to determine the part number for the field replaceable unit (FRU):

CCIN or FFC	Type and model	Part number	Description	Location code
D93	Any	See system unit parts	32 MB, parity, 70 nsec memory module	

Failing function code D94

The memory module might be failing.

Use the following table to determine the part number for the field replaceable unit (FRU):

CCIN or FFC	Type and model	Part number	Description	Location code
D94	Any	See system unit parts	64 MB, ECC, 70 nsec memory module	

Failing function code D95

The graphics adapter might be failing.

Use the following table to determine the part number for the field replaceable unit (FRU):

CCIN or FFC	Type and model	Part number	Description	Location code
D95	Any	94H0029	GXT550P graphics adapter	

Failing function code D96

The graphics adapter might be failing.

Use the following table to determine the part number for the field replaceable unit (FRU):

CCIN or FFC	Type and model	Part number	Description	Location code
D96	Any	93H6267	GXT255P high performance PCI graphics adapter	

Failing function code D97

The operator panel/speaker assembly might be failing.

Use the following table to determine the part number for the field replaceable unit (FRU):

CCIN or FFC	Type and model	Part number	Description	Location code
D97	8203-E4A, 9407-M15, 9408-M25	10N9737	Operator panel/speaker assembly	U n-E1
D97	8204-E8A, 9409-M50	42R5505	Operator panel/speaker assembly	U n-E1

D97	9117-MMA	93H7439	Operator panel/speaker assembly	
-----	----------	---------	---------------------------------	--

Failing function code E10

The riser card might be failing.

Use the following table to determine the part number for the field replaceable unit (FRU):

CCIN or FFC	Type and model	Part number	Description	Location code
E10		73H4532	Riser card	
E10		73H4532	Riser card	
E10		23L8117	Riser card	
E10			Refer to FFC 227	

Failing function code E11

The memory module might be failing.

Use the following table to determine the part number for the field replaceable unit (FRU):

CCIN or FFC	Type and model	Part number	Description	Location code
E11	Any	See system unit parts	128 MB, ECC, 50 nsec memory module	

Failing function code E12

The memory module might be failing.

Use the following table to determine the part number for the field replaceable unit (FRU):

CCIN or FFC	Type and model	Part number	Description	Location code
E12	Any	93H6821	128 MB, ECC, 60 nsec memory module	
E12	Any	93H6823	128 MB, ECC, 60 nsec memory module	
E12	Any	93H6822	128 MB, ECC, 60 nsec memory module	
E12	Any	93H4702	128 MB, ECC, 60 nsec memory module	

Failing function code E13

The memory module might be failing.

Use the following table to determine the part number for the field replaceable unit (FRU):

CCIN or FFC	Type and model	Part number	Description	Location code
E13	Any		128 MB, ECC, 70 nsec memory module	

Failing function code E14

The memory module might be failing.

Use the following table to determine the part number for the field replaceable unit (FRU):

CCIN or FFC	Type and model	Part number	Description	Location code
E14	Any		128 MB, parity, 50 nsec memory module	

Failing function code E15

The memory module might be failing.

Use the following table to determine the part number for the field replaceable unit (FRU):

CCIN or FFC	Type and model	Part number	Description	Location code
E15	Any		128 MB, parity, 60 nsec memory module	

Failing function code E16

The memory module might be failing.

Use the following table to determine the part number for the field replaceable unit (FRU):

CCIN or FFC	Type and model	Part number	Description	Location code
E16	Any		128 MB, parity, 70 nsec memory module	

Failing function code E17

The memory module might be failing.

Use the following table to determine the part number for the field replaceable unit (FRU):

CCIN or FFC	Type and model	Part number	Description	Location code
E17	Any	19H0288	Memory 16 MB memory module	

Failing function code E18

The memory module might be failing.

Use the following table to determine the part number for the field replaceable unit (FRU):

CCIN or FFC	Type and model	Part number	Description	Location code
E18	Any	35H8751	Memory 64 MB memory module	

Failing function code E19

The power supply sensor failed.

Use the following table to determine the part number for the field replaceable unit (FRU):

CCIN or FFC	Type and model	Part number	Description	Location code
E19	Any	See system unit parts	Power supply sensor failed I/O planar	

Failing function code E1A

The memory card might be failing.

Use the following table to determine the part number for the field replaceable unit (FRU):

CCIN or FFC	Type and model	Part number	Description	Location code
E1A	Any	23L7595 04N5011	4 GB memory card	

Failing function code E22

The video cable might be failing.

Use the following table to determine the part number for the field replaceable unit (FRU):

CCIN or FFC	Type and model	Part number	Description	Location code
E22	Any		Video cable (generic)	

Failing function code E23

The audio cable might be failing.

Use the following table to determine the part number for the field replaceable unit (FRU):

CCIN or FFC	Type and model	Part number	Description	Location code
E23	Any		Audio cable (generic)	

Failing function code E24

The resistor assembly might be failing.

Use the following table to determine the part number for the field replaceable unit (FRU):

CCIN or FFC	Type and model	Part number	Description	Location code
E24	Any	94H0623	Resistor assembly	

Failing function code E26

The power distribution card might be failing.

Use the following table to determine the part number for the field replaceable unit (FRU):

CCIN or FFC	Type and model	Part number	Description	Location code
-------------	----------------	-------------	-------------	---------------

E26	Any	See system unit parts	Power distribution card	
-----	-----	-----------------------	-------------------------	--

Failing function code E29

The cache might be failing.

Use the following table to determine the part number for the field replaceable unit (FRU):

CCIN or FFC	Type and model	Part number	Description	Location code
E29	Any	09L2105	32 MB cache (located on the LVD SCSI RAID adapter) (includes battery)	

Failing function code E2A

The cache might be failing.

Use the following table to determine the part number for the field replaceable unit (FRU):

CCIN or FFC	Type and model	Part number	Description	Location code
E2A	Any	03N7031	128 MB cache, U.S. (includes battery)	
E2A	Any	19K0561	128 MB cache, Japan (includes battery)	

Failing function code E30

The cache battery might be failing.

Use the following table to determine the part number for the field replaceable unit (FRU):

CCIN or FFC	Type and model	Part number	Description	Location code
E30	Any	44H8429	32 MB cache Battery (Located on the LVD SCSI RAID adapter)	

Failing function code E3A

The cache battery might be failing.

Use the following table to determine the part number for the field replaceable unit (FRU):

CCIN or FFC	Type and model	Part number	Description	Location code
E3A	Any	37L6903	128 MB cache battery, U.S.	
E3A	Any	00N9561	128 MB cache battery, Japan	

Failing function code Exx

Refer to the Firmware Checkpoint Three-Digit Error Code section of the service manual.

Use the following table to determine the part number for the field replaceable unit (FRU):

CCIN or FFC	Type and model	Part number	Description	Location code
Exx	Any		(xx represents any character) Refer to the Firmware Checkpoint Three-Digit Error Code section of the service manual.	

Failing function code Fxx

Refer to the Firmware Checkpoint Three-Digit Error Code section of the service manual.

Use the following table to determine the part number for the field replaceable unit (FRU):

CCIN or FFC	Type and model	Part number	Description	Location code
Fxx	Any		(xx represents any character) Refer to the Firmware Checkpoint Three-Digit Error Code section of the service manual.	

Failing items

This information is a list of failing item codes.

The failing items are listed in numerical sequence.

FI00015

FI00015 is not supported on these models. Continue with the next FRU in the list.

FI00017

FI00017 is not supported on these models. Continue with the next FRU in the list.

FI00020

FI00020 is not supported on these models. Continue with the next FRU in the list.

FI00021

FI00021 indicates that the combined function I/O processor (CFIOP) is the failing item.

Note the CFIOP type and refer to Managing PCI adapters to determine the FRU part number to replace.

FI00022

FI00022 indicates that the Licensed Internal Code for the service processor may be the failing item.

Ask your next level of support for assistance.

FI00040

FI00040 indicates that the backplane or a connection to the backplane might be failing.

See the symbolic FRU BACKPLN.

FI00047

FI00047 is not supported on these models. Continue with the next FRU in the list.

FI00050

FI00050 is not supported on these models. Continue with the next FRU in the list.

FI00055

FI00055 indicates that a primary optical link cable is the failing item.

This is either the optical bus cable for the bus you are working with or its paired bus cable on the optical link card.

Note the cable type and refer to Site and hardware planning to determine the FRU part number to replace.

FI00056

FI00056 indicates that any optical bus cable or a missing optical bus wrap connector is the failing item.

Refer to Site and hardware planning for cable FRU part numbers or Managing PCI adapters for wrap connector FRU part numbers to replace.

FI00057

FI00057 indicates that the secondary optical link cable is the failing item.

This is the optical cable that runs between the bus expansion adapter cards in two separate expansion units. Note the cable type and refer to Site and hardware planning to determine the FRU part number to replace.

FI00060

FI00060 is not supported on these models. Continue with the next FRU in the list.

FI00062

FI00062 is not supported on these models. Continue with the next FRU in the list.

FI00065

FI00065 is not supported on these models. Continue with the next FRU in the list.

FI00070

FI00070 indicates that a storage device attached to the IPL device IOP is the failing item.

Determine the IPL device that is failing by doing the following:

1. In the navigation area, open **Systems Management**.
2. Open **Servers**.
3. Click the server on which the logical partition is located.
4. Select the logical partition and click the **Properties** task.

5. In the Properties window, click the **Settings** tab.

Note the IPL storage device type and refer to Finding parts, locations, and addresses to determine the FRU part number to replace.

If the IPL storage device is not the failing item, then any storage device attached to the IPL device IOP might be the failing item.

FI00072

FI00072 indicates that the load-source media is the failing item.

1. Choose from the following options:
 - If the load source is tape, exchange the tape in the alternate IPL tape unit.
 - If the load source is an optical storage unit, exchange the compact disk.
 - If the load source is a hard disk drive, exchange the hard disk drive.
2. If replacing the media does not work, try replacing the drive. Note the device type and refer to Finding parts, locations, and addresses to determine the FRU part number to replace.

FI00090

FI00090 indicates that the removable media device for an alternate IPL is the failing item.

Determine the device that is failing by doing the following:

1. Select function **01** (Select IPL) on the control panel and press **Enter** to verify that the active IPL type is D.
Note: Use the system configuration list to identify the device.
The possible failing devices are the following type numbers: 3490, 3570, 3590, 632x, 6382, 6383, 6386, 6387, 63A0, 7208, 9348, and 9427.
2. Use the service information for the specific removable media unit for an alternate IPL to analyze the device failure.

FI00092

FI00092 indicates that the load source for an alternate IPL or the interface to the load source is the failing item.

Perform the following steps:

1. If the load source is an optical unit, you may need to perform function 3 to IPL the system again. This will make the unit ready.
2. Locate the alternate load source device for the system.
3. Replace the device.

FI00096

FI00096 indicates that the IOP attached to the load-source device is the failing item.

Perform the following steps:

1. Verify that the IPL type is correct by performing one of the following:
 - **If you are using a control panel:** Select function 01 on the control panel and press **Enter** to display the present IPL mode.
 - **If you are using the HMC,** perform the following steps:
 - a. In the Navigation Area, open **Systems Management**.
 - b. Open **Servers**.

- c. Click the server on which the logical partition is located.
 - d. Open **Partitions**.
 - e. Select the logical partition and click the **Properties** task.
 - f. In the Properties window, click the **Settings** tab.
2. The failing IOP might have a removable storage I/O adapter FRU. Replace the storage IOA using symbolic FRU STORIOA.
 3. Locate the alternate load source for a system,
 4. Replace the device.

FI00098

FI00098 indicates that the load-source disk device is the failing item.

Perform the following steps:

1. Determine the disk unit 1 type number. It is printed on a label on the front of the system frame.
2. If the system does not have a label that identifies the disk unit type, you can determine the part number of the disk unit by looking at a label located on the disk unit. You must remove the disk unit to see this label.
3. Replace the disk unit.
4. Locate the alternate load source device for the system.
5. Replace the device.

FI00099

FI00099 indicates that the Licensed Internal Code failed or responded in an unpredictable way.

Ask your next level of support for assistance.

FI00121

FI00121 indicates that any tape or optical storage device attached to the I/O (SCSI) bus of this IOP may be the failing item.

Use the device type to determine the part. Note the device type and refer to Managing devices to determine the FRU part number to replace.

FI00122

FI00122 indicates that a reserved IOA port on the IOP is the failing item.

If the IOP is type 2624, the failing item is type 6146 IOA.

Note the IOA type and refer to Managing PCI adapters to determine the FRU part number to replace.

FI00123

FI00123 indicates that the device terminating plug might be failing.

Go to symbolic FRU DEVTERM.

FI00124

FI00124 is not supported on these models. Continue with the next FRU in the list.

FI00130

FI00130 indicates that the Licensed Internal Code for one of the IOPs or IOAs is the failing item.

Determine the IOP or IOA type and location:

1. Determine the address of the IOP or IOA card. See The system reference code format description.
2. Determine the location of the IOP or IOA card. See Part locations and location codes and get the type from the card in that location or address.
3. Look for PTFs associated with the reference code and the identified hardware type and have the customer apply them.

FI00131

FI00131 indicates that one of the IOPs or IOAs, if active, is the failing item.

Determine the IOP or IOA type and location:

1. Determine the address of the IOP or IOA card. See The system reference code format description.
2. Determine the location of the IOP or IOA card. See Part locations and location codes and get the type from the card in that location or address.
3. Use the IOP or IOA type to determine the part to replace.

FI00132

FI00132 indicates that one of the IOAs is the failing item.

Perform MABIP55 to isolate the failing IOA.

FI00141

FI00141 indicates that the IOP for the 7208 tape drive is the failing item.

The failing IOP is the type 2621 IOP.

Note the IOP type and refer to Managing PCI adapters to determine the FRU part number to replace.

FI00142

FI00142 is not supported on these models. Continue with the next FRU in the list.

FI00180

FI00180 is not supported on these models. Continue with the next FRU in the list.

FI00182

FI00182 indicates that the local optical link card or the SPD optical bus driver might be failing.

For Models 270 and 820, FI00182 indicates that the local optical link card is the failing item. For Models 830, 840, SB2, and SB3, FI00182 indicates that the SPD optical bus driver is the failing item.

- If the fifth character of word 5 (xxxx xxxx) is 1, 5, 9, or D-2686 (266 MB/s)
- If the fifth character of word 5 (xxxx xxxx) is 3, 7, B, or F-2688 (1062 MB/s)

FI00185

FI00185 indicates that the 12-port ASCII workstation attachment cable is the failing item.

Note the cable type and refer to Site and hardware planning to determine the FRU part number to replace.

FI00186

FI00186 indicates that the optical cable might be failing.

- For the Model 270 and 820, FI00186 indicates that the optical cable in the top position (even bus) of the optical link card is the failing item.
- For the Model 830, 840, SB2, and SB3, FI00186 indicates that the optical cable in the top position (lower number bus) of the SPD optical Bus Driver is the failing item.

FI00187

FI00187 is not supported on these models. Continue with the next FRU in the list.

FI00189

FI00189 is not supported on these models. Continue with the next FRU in the list.

FI00200

FI00200 indicates that the ac module or the removable power cable is the failing item.

The following list shows the possible failing ac modules.

- System unit -- part SPNLCRD
- System unit expansion (FC 5070, 5072), storage expansion unit (FC 5080, 5082)
- System unit expansion (FC 5071, 5073), storage expansion tower (FC 5081, 5083)

Note the cable type and refer to Site and hardware planning to determine the FRU part number to replace.

FI00203

FI00203 indicated that the remote bus expansion adapter card or the remote SPD optical bus receiver card might be failing.

For the Models 270 and 820, FI00203 indicates that the remote bus expansion adapter card in the bus expansion unit is the failing item.

Use the adapter card type in the bus expansion unit to determine the part.

For Models 830, 840, SB2, and SB3, FI00203 indicates that the remote SPD optical bus receiver card in the expansion tower is the failing item.

Use the receiver card type in the expansion tower to determine the part.

FI00204

FI00204 indicates that the bus cable between the system unit and an expansion unit or the bus cable between two expansion units is the failing item.

FI00205

FI00205 indicates that the remote bus expansion adapter or the remote SPD optical bus receiver might be failing.

For Models 270 and 830, FI00205 indicates that the remote bus expansion adapter for the paired bus is the failing item. Use the adapter card type in the bus expansion unit to determine the part.

For Models 830, 840, SB2, and SB3, FI00205 indicates that the remote SPD optical bus receiver on the paired bus is the failing item. Use the receiver card type in the expansion unit bus to determine the part.

FI00206

FI00206 is not supported on these models. Continue with the next FRU in the list.

FI00230

FI00230 indicates that the Licensed Internal Code for the failing node is the failing item and needs to be restored.

Determine the type of node and select the Licensed Internal Code load.

- **Primary node** - AJSFDJ04
- **Secondary node** - AJSFDJ05

FI00235

FI00235 indicates that an SPCN cable that connects two frames or a frame to a node is the failing item. This failing item is applicable only if an SPCN cable is installed.

The following list shows the lengths of the possible failing items.

- SPCN cable (6 meters)
- SPCN cable (15 meters)
- SPCN cable (30 meters)
- SPCN cable (60 meters)
- Optical SPCN cable (100 meters)
- SPCN optical adapter
- SPCN port cable (frame-to-node)
- Frame-to-frame cable
- SPCN optical adapter

Note the cable type and refer to the Site and hardware planning to determine the FRU part number to replace.

FI00236

FI00236 is not supported on these models. Continue with the next FRU in the list.

FI00237

FI00237 is not supported on these models. Continue with the next FRU in the list.

FI00238

FI00238 is not supported on these models. Continue with the next FRU in the list.

FI00239

FI00239 is not supported on these models. Continue with the next FRU in the list.

FI00240

FI00240 is not supported on these models. Continue with the next FRU in the list.

FI00244

FI00244 is not supported on these models. Continue with the next FRU in the list.

FI00245

FI00245 indicates that the card enclosure for an unknown unit type is the failing item.

See the symbolic FRU BACKPLN.

FI00246

FI00246 is not supported on these models. Continue with the next FRU in the list.

FI00248

FI00248 is not supported on these models. Continue with the next FRU in the list.

FI00253

FI00253 is not supported on these models. Continue with the next FRU in the list.

FI00255

FI00255 is not supported on these models. Continue with the next FRU in the list.

FI00256

FI00256 is not supported on these models. Continue with the next FRU in the list.

FI00300

FI00300 indicates that media is the failing item.

If the load source is:

- Tape, exchange the tape in the alternate IPL tape unit.
- An optical storage unit, exchange the compact disc.
- A hard disk drive, exchange the hard disk drive. Use the following table to determine the part number for the field replaceable unit (FRU):

CCIN or FFC	Type and model	Part number	Description	Location code
	9406-MMA, 9117-MMA	42R4233	73 GB SAS DASD with tray, 15 K RPM	Un-P3-Dx
	9406-MMA, 9117-MMA	10N7199	73 GB SAS DASD with tray, 15 K RPM	Un-P3-Dx
	9406-MMA, 9117-MMA	42R4234	146 GB SAS DASD with tray, 15 K RPM	Un-P3-Dx
	9406-MMA, 9117-MMA	10N7203	146 GB SAS DASD with tray, 15 K RPM	Un-P3-Dx
	9406-MMA, 9117-MMA	42R5648	300 GB SAS DASD with tray, 15 K RPM	Un-P3-Dx
	9406-MMA, 9117-MMA	10N7207	300 GB SAS DASD with tray, 15 K RPM	Un-P3-Dx
	0595, 5095, 7311-D20	00P3829	18.2 GB 10K RPM SCSI disk drive/carrier	Un-DBx-Dxx
	0595, 5095, 7311-D20	00P3064	18.2 GB 10K RPM SCSI disk drive/carrier	Un-DBx-Dxx

	0595, 5095, 7311-D20	80P3161	36.4 GB 15K RPM Ultra3 SCSI disk drive/carrier	Un-DBx-Dxx
	0595, 5095, 7311-D20	00P2697	36.4 GB 15K RPM Ultra3 SCSI disk drive/carrier	Un-DBx-Dxx
	0595, 5095, 7311-D20	09P3928	73.4 GB 10K RPM, 80-pin SCSI disk drive/carrier	Un-DBx-Dxx
	0595, 5095, 7311-D20	09P4890	73.4 GB 10K RPM, 80-pin SCSI disk drive/carrier	Un-DBx-Dxx
	0595, 5095, 7311-D20	03N5270	300 GB Ultra320 10K rpm 80 pin SCSI disk drive/carrier	Un-DBx-Dxx
	0595, 5095, 7311-D20	03N6335	300 GB Ultra320 10K rpm 80 pin SCSI disk drive/carrier	Un-DBx-Dxx

If installing from:

- Tape, exchange the tape in the alternate IPL tape unit.
- An optical storage unit, exchange the compact disc.

FI00301

FI00301 indicates that the magnetic storage I/O processor (MSIOP) or the combined function I/O processor (CFIOP) is the failing item.

Note the IOP type and refer to Managing PCI adapters to determine the FRU part number to replace.

FI00302

FI00302 indicates that the Licensed Internal Code for the magnetic storage I/O processor (MSIOP) or the combined function I/O processor (CFIOP) is the failing item.

Ask your next level of support for assistance.

FI00310

FI00310 is not supported on these models. Continue with the next FRU in the list.

FI00315

FI00315 indicates that the battery power unit installation time life has been exceeded.

Check any attached units that have battery power units and perform maintenance as needed.

FI00316

FI00316 indicates that no I/O processors were found on the bus.

Verify the configuration information for the system. If a bus is configured to be empty, there is no problem.

FI00317

FI00317 indicates that the I/O processor cards at consecutive direct select addresses appear to be failing.

Check the I/O processor cards to ensure they are properly seated in their connectors and verify that the backplane is not damaged. The I/O processor cards or a damaged backplane could cause this problem.

FI00318

FI00318 indicates that an I/O adapter attached to an I/O processor card on the failing bus is the failing item.

Note the IOA type and refer to Managing PCI adapters to determine the FRU part number to replace.

FI00319

FI00319 indicates that the Licensed Internal Code on an I/O processor is the failing item.

Install a PTF to correct the problem.

Ask your next level of support for assistance.

FI00320

FI00320 indicates that the display station used as the console is the failing item.

FI00350

For Models 830, 840, SB2, and SB3 only, FI00350 indicates that the alternate IPL device is the failing item.

See the service information for the specific device type and model installed on the system to determine the part number.

FI00360

FI00360 indicates that the IPL disk device is the failing item.

Use the following table to determine the part number for the field replaceable unit (FRU):

CCIN or FFC	Type and model	Part number	Description	Location code
	9406-MMA, 9117-MMA	42R4233	73 GB SAS DASD with tray, 15 K RPM	Un-P3-Dx
	9406-MMA, 9117-MMA	10N7199	73 GB SAS DASD with tray, 15 K RPM	Un-P3-Dx
	9406-MMA, 9117-MMA	42R4234	146 GB SAS DASD with tray, 15 K RPM	Un-P3-Dx
	9406-MMA, 9117-MMA	10N7203	146 GB SAS DASD with tray, 15 K RPM	Un-P3-Dx
	9406-MMA, 9117-MMA	42R5648	300 GB SAS DASD with tray, 15 K RPM	Un-P3-Dx
	9406-MMA, 9117-MMA	10N7207	300 GB SAS DASD with tray, 15 K RPM	Un-P3-Dx
	0595, 5095, 7311-D20	00P3829	18.2 GB 10K RPM SCSI disk drive/carrier	Un-DBx-Dxx
	0595, 5095, 7311-D20	00P3064	18.2 GB 10K RPM SCSI disk drive/carrier	Un-DBx-Dxx

	0595, 5095, 7311-D20	80P3161	36.4 GB 15K RPM Ultra3 SCSI disk drive/carrier	Un-DBx-Dxx
	0595, 5095, 7311-D20	00P2697	36.4 GB 15K RPM Ultra3 SCSI disk drive/carrier	Un-DBx-Dxx
	0595, 5095, 7311-D20	09P3928	73.4 GB 10K RPM, 80-pin SCSI disk drive/carrier	Un-DBx-Dxx
	0595, 5095, 7311-D20	09P4890	73.4 GB 10K RPM, 80-pin SCSI disk drive/carrier	Un-DBx-Dxx
	0595, 5095, 7311-D20	03N5270	300 GB Ultra320 10K rpm 80 pin SCSI disk drive/carrier	Un-DBx-Dxx
	0595, 5095, 7311-D20	03N6335	300 GB Ultra320 10K rpm 80 pin SCSI disk drive/carrier	Un-DBx-Dxx

FI00380

FI00380 indicates that the workstation card might be failing.

On the bus with the system console or the failing logical partition's console, the failing item is the first workstation IOP card or the workstation IOA card. The bus with the system console is bus 0001. For systems with multiple logical partitions, the logical partition's console is on bus 0001 and the consoles for other logical partitions are determined by the LPAR configuration.

Note the IOP or IOA type and refer to Managing PCI adapters to determine the FRU part number to replace.

FI00500

FI00500 indicates that the I/O (SCSI) bus cable is the failing item.

See FI01140.

FI00580

FI00580 indicates that any storage device may be the failing item.

The address of the failing storage device cannot be determined.

Note the device type and refer to Finding parts, locations, and addresses to determine the FRU part number to replace.

FI00581

FI00581 indicates that a storage device at the address identified by the problem isolation procedures for the reference code is the failing item.

Use the service information of the I/O device to continue analyzing the problem.

Note the device type and refer to Finding parts, locations, and addresses to determine the FRU part number to replace.

FI00584

FI00584 indicates that any storage device might be the failing item.

The address of the failing storage device cannot be determined.

For device FRU part numbers, refer to Finding parts, locations, and addresses.

FI00601

FI00601 indicates that the display station is the failing item.

If a link protocol converter is used to connect the console to the system, the protocol converter is the failing item.

Refer to the display station or link protocol converter documentation for service information.

FI00602

FI00602 indicates that the cable between the workstation attachment and the device is the failing item.

Note the cable type and refer to Site and hardware planning to determine the FRU part number to replace.

FI00603

FI00603 indicates that the 5299 multiconnector is the failing item.

Note the cable type and refer to Site and hardware planning to determine the FRU part number to replace.

FI00604

FI00604 indicates that a printer is the failing item.

Use the printer device information to analyze the problem.

FI00605

FI00605 indicates that a magnetic stripe reader on a display station is the failing item.

Refer to the documentation for the display station for service information.

FI00606

FI00606 indicates that the storage media is the failing item.

FI00607

FI00607 indicates that a selector light pen attached to a display station is the failing item.

Refer to the documentation for the display station for service information.

FI00608

FI00608 indicates that the link protocol converter is the failing item.

Refer to the documentation for the link protocol converter for service information.

FI00610

FI00610 indicates that the twinaxial workstation IOP or the twinaxial workstation IOA attached to a combined function I/O processor (CFIOP), communications IOP, or combined function IOP is the failing item.

Use the workstation IOP or IOA type to determine the part.

Note the CFIOP or IOA type and refer to Managing PCI adapters to determine the FRU part number to replace.

FI00611

FI00611 is not supported on these models. Continue with the next FRU in the list.

FI00612

FI00612 is not supported on these models. Continue with the next FRU in the list.

FI00613

FI00613 is not supported on these models. Continue with the next FRU in the list.

FI00614

FI00614 indicates that a unit reference code of FFFF was indicated when the user entered the ANZPRB (Analyze Problem) command from a workstation.

The failing items for this error can be identified by running the complete ANZPRB command. The failing items are also in the problem log when the WRKPRB command is entered.

FI00615

FI00615 indicates that the twinaxial workstation attachment cable is the failing item.

Check the twinaxial workstation attachment cable for the FRU part number.

Note the cable type and refer to Site and hardware planning to determine the FRU part number to replace.

FI00616

FI00616 indicates that the 5259 migration data link is the failing item.

Exchange the 5259 migration data link.

Note the cable type and refer to Site and hardware planning to determine the FRU part number to replace.

FI00626

FI00626 indicates that the modem on the failing port is the failing item.

Exchange the modem.

FI00630

FI00630 indicates that the multi-line communications IOP is the failing item.

Note the IOP type and refer to Managing PCI adapters to determine the FRU part number to replace.

FI00631

FI00631 indicates that a cable other than the cable from the workstation IOA to the first device is the failing item.

Note the cable type and refer to Site and hardware planning to determine the FRU part number to replace.

FI00632

FI00632 indicates that the cable from the workstation IOA to the first device is the failing item.

Note the cable type and refer to Site and hardware planning to determine the FRU part number to replace.

FI00700

FI00700 indicates that the remote data terminal equipment (DTE) or an attached device is the failing item.

Report this problem to the operator of the remote equipment.

FI00701

FI00701 indicates that a local communications cable is the failing item.

Use the cable to determine the part.

Note the cable type and refer to Site and hardware planning to determine the FRU part number to replace.

FI00702

FI00702 indicates that the local cable for the automatic call unit is the failing item.

Check the automatic call unit interface cable for the part number.

Note the cable type and refer to Site and hardware planning to determine the FRU part number to replace.

FI00703

FI00703 indicates that the automatic call unit is the failing item.

Refer to the documentation for the automatic call unit for service information.

FI00704

FI00704 indicates that the local data circuit-terminating equipment (DCE) is the failing item.

Refer to the documentation for the DCE for service information.

FI00705

FI00705 indicates that the remote data circuit-terminating equipment (DCE) is the failing item.

Report this problem to the operator of the remote equipment.

FI00708

FI00708 indicates that the local communications cable (X.21 interface) is the failing item.

Check the communications cable for the part number.

Note the cable type and refer to Site and hardware planning to determine the FRU part number to replace.

FI00709

FI00709 indicates that the local communications cable (V.35 interface) is the failing item.

Check the communications cable for the part number.

Note the cable type and refer to Site and hardware planning to determine the FRU part number to replace.

FI00710

FI00710 indicates that the local communications cable (V.24 interface with remote power on) is the failing item.

The remote power-on feature is given support by using an available pin on the EIA-232/V.24 enhanced or EIA-232/V.24 non-enhanced cables. Check the communications cable for the part number.

Note the cable type and refer to Site and hardware planning to determine the FRU part number to replace.

FI00711

FI00711 indicates that the local communications cable (token-ring interface cable) is the failing item.

Note: An IBM[®] Cabling System Patch Cable or a comparable cable might have been supplied by the user to increase the length of this cable. Any cable attached to the token-ring interface cable may also be the failing item.

Note the cable type and refer to Site and hardware planning to determine the FRU part number to replace.

FI00712

FI00712 indicates that the token-ring access unit is the failing item.

Refer to the documentation for the token-ring access unit for service information.

FI00716

FI00716 indicates that the EIA-232/V.24 enhanced cable is the failing item.

Check the communications cable for the part number.

Note the cable type and refer to Site and hardware planning to determine the FRU part number to replace.

FI00717

FI00717 indicates that the EIA-232/V.24 non-enhanced cable is the failing item.

Check the communications cable for the part number.

FI00718

FI00718 indicates that an IOP card is the failing item.

Note the CFIOP type and refer to Managing PCI adapters to determine the FRU part number to replace.

FI00719

FI00719 indicates that an IOA card is the failing item.

1. Is the IOA location information available in the Service Action Log entry, Hardware Service Manager (HSM), or in Service Focal Point on the Hardware Management Console?
 - **Yes:** Exchange the IOA. Note the IOA type and refer to Managing PCI adapters to determine the FRU part number to replace.
 - **No:** Continue with the next step.
2. Determine the address of the IOA card. See The system reference code format description.
3. Determine the location of the IOA card. See Part locations and location codes for the model you are working on and get the type from the card at that address.
4. Exchange the IOA. Note the IOA type and refer to Managing PCI adapters to determine the FRU part number to replace.

FI00720

FI00720 indicates that the ethernet transceiver is the failing item.

Verify that the signal quality error switch in the transceiver that the ethernet is attached to is set to active.

See the transceiver operator's guide for the correct operation or the correct remove and replace procedure.

FI00721

FI00721 indicates that the token-ring IOA card is the failing item.

Note the IOA type and refer to Managing PCI adapters to determine the FRU part number to replace.

FI00722

FI00722 indicates that the cable attached to the local area network IOA is the failing item.

FI00723

FI00723 indicates that the communications two-port adapter cable for the communications IOA card is the failing item.

Exchange the communications two-port adapter cable.

If this does not correct the problem, use the IOA type to determine the part. Note the IOA type and refer to Managing PCI adapters to determine the FRU part number to replace.

FI00725

FI00725 indicates that the ethernet IOA card is the failing item.

Use the IOA type to determine the part. Note the IOA type and refer to Managing PCI adapters to determine the FRU part number to replace.

FI00726

FI00726 indicates that a communications IOA card is the failing item:

Use the IOA type to determine the part. Note the IOA type and refer to Managing PCI adapters to determine the FRU part number to replace.

FI00727

FI00727 indicates that one of the IOAs attached to either a combined function I/O processor (CFIOP), multiline communications IOP or an Integrated xSeries[®] R Server (IXS) for iSeries[®] TM server is the failing item.

Perform MABIP55 to isolate the failing IOA.

FI00728

FI00728 indicates that the local communications cable (RS449/V.36 interface) is the failing item.

Check the communications cable for the part number.

Also, note the cable type and refer to Site and hardware planning to determine the FRU part number to replace.

FI00730

FI00730 indicates that the Licensed Internal Code module for an I/O card may be the failing item.

Ask your next level of support for assistance.

FI00731

FI00731 is not supported on these models. Continue with the next FRU in the list.

FI00732

FI00732 is not supported on these models. Continue with the next FRU in the list.

FI00733

FI00733 is not supported on these models. Continue with the next FRU in the list.

FI00734

FI00734 is not supported on these models. Continue with the next FRU in the list.

FI00735

FI00735 is not supported on these models. Continue with the next FRU in the list.

FI00741

FI00741 indicates that the telephone cable to the wall outlet is the failing item.

Check the cable for the part number.

Note the cable type and refer to Site and hardware planning to determine the FRU part number to replace.

FI00742

FI00742 indicates that the communications coupler is the failing item.

Check the coupler for the part number.

Note the coupler type and refer to Site and hardware planning to determine the FRU part number to replace.

FI00751

FI00751 indicates that the Licensed Internal Code module is the failing item.

Ask your next level of support for assistance.

FI00810

FI00810 indicates that the magnetic tape is the failing item.

Exchange the magnetic tape.

FI00830

FI00830 indicates that the external signal cable is the failing item.

See EXTSCSI for cable part numbers.

FI00832

FI00832 indicates that the external signal cable is the failing item.

See EXTSCSI for cable part numbers.

FI00841

FI00841 indicates that the terminating plug for the attached device is the failing item.

- For tape devices, see FI00880

FI00842

FI00842 indicates that the external signal cable for the attached device is the failing item.

See symbolic FRU EXTSCSI.

FI00844

FI00844 indicates that the device controller for the attached device is the failing item.

- For tape devices, see FI00882

FI00845

FI00845 indicates that the device controller for the attached device is the failing item.

See symbolic FRU EXTSCSI.

FI00850

FI00850 indicates that the interface cables attached to the tape IOP are the failing items.

FI00851

FI00851 indicates that the I/O device attached to the tape IOP is the failing item.

Use the service information of the I/O device to continue analyzing the problem.

Note the device type and refer to Managing devices to determine the FRU part number to replace.

FI00856

FI00856 indicates that an active tape IOP is the failing item.

Use the IOP type to determine the part.

Note the CFIO type and refer to Managing PCI adapters to determine the FRU part number to replace.

FI00870

FI00870 indicates that a storage device is the failing item.

Use the device type to determine the part. If a device location is not listed in the Service Action Log entry or in Hardware Service Manager (HSM), then the failing device is either externally attached or the failing device may be part of an unsupported configuration. If the device is in a 3995 or 3996 optical library, refer to the Maintenance Information for the 3995 or 3996 optical library to replace the failing device.

Note: The 636x tape unit is located in the FC 5032 removable storage unit.

FI00871

FI00871 indicates that the attached tape device is the failing item.

For part number information, refer to the device service information.

- 3490 - External 1/2 inch cartridge drive: Refer to the device information to determine the part number to replace.
- 3570 - External 3570 cartridge drive: Refer to the device information to determine the part number to replace.
- 358x - External Ultrium drive: Refer to the device service information to determine the part number to replace.
- 3590 - External 1/2 cartridge tape drive: Refer to the device service information to determine the part number to replace.
- 3592 - External 1/2 inch cartridge drive: Refer to the device service information to determine the part number to replace.
- 4685 - VXA2 drive.
- 6381 - Internal 1/4 inch cartridge drive with QIC-2GB (DC) on the door.
- 6382 - Internal 1/4 inch cartridge drive with QIC-4GB (DC) on the door.
- 6382 - Internal 1/4 inch cartridge drive with QIC-4GB (DC) on the door.
- 6383 - Internal 1/4 inch cartridge drive with MLR1-S on the front cover.
- 6384 - Internal 1/4 inch cartridge drive with SLR60 on the front cover.
- 6386 - Internal 1/4 inch cartridge drive with MLR3 on the front cover.
- 6387 - Internal 1/4 inch cartridge drive with SLR100 on the front cover.
- 7207 Model 122 - External 1/4 inch cartridge drive with QIC-4GB-DC on the door.
- 7208 - External 8mm tape drive; refer to the device service information to determine the part number(s) to replace.
- 7239 Model 308 - External 1/4 inch cartridge tape library.

- 9348 - External 1/2 inch reel tape unit. Is one of the following status codes displayed anywhere on the 9348 control panel? (x = any number)
 - Exxx
 - Fxxx
 - ***xX
 - *****
 - **No:** Refer to the 9348 Service Information and use the "Running Diagnostic Tests" procedure to run Diagnostic Test 1. If the test fails, use the 9348 Service Information to determine the failing items.
 - **Yes:** Use the "Status Codes" section of the 9348 Service Information to determine the failing items.

FI00872

FI00872 indicates that the interface is the failing item.

- Internal device: See FI01140.
- External device: See symbolic FRU EXTSCSI.

FI00880

FI00880 indicates that a terminating plug on the device bus to this IOP is the failing item.

Note: If the unit is a 9427, an internal terminating plug is used. See the service information for the specific device.

The following list shows the possible failing items:

- Terminating plug for 2440 Tape Unit -- part 79X3795
- Terminating plug for 3490, 3570, 3590, and 7208 Model 342 Tape Units -- part 61G8324
- SCSI differential terminating plug for 3995 iSeries Optical Library Dataserver -- part 79X3795
- SCSI single-ended terminating plug for 3995 iSeries Optical Library Dataserver Models C4x -- part 34H5608
- Terminator for 637x, 638x, and 6390 Tape Units -- Terminator is part of the disk unit backplane. Use the IOA type and see the symbolic FRU DEVTERM to determine the correct part.
- Terminating plug for 63A0 Tape Unit -- See device documentation.
- Terminating plug for 7208 Model 002 Tape Drive -- part 91F0721
- Terminating plug for 7208 Model 012 Tape Drive -- part 46G2599
- Terminating plug for 7208 Model 222 Tape Drive -- part 46G2599
- Terminating plug for 7208 Model 232 Tape Drive -- part 79X3795
- Terminating plug for 7208 Model 234 Tape Drive -- part 79X3795
- Terminating plug for 9348 Tape Unit -- part 79X3795

FI00882

FI00882 indicates that the addressed unit is the failing item.

Determine the address and type of the failing unit. See The system reference code format description.

If one of the following device types is the failing item, see the service information for the device model installed on the system: * 2440 * 3490 * 3570 * 3590 * 3995 * 63A0 * 7208 * 9347* 9348 * 9427.

FI00883

FI00883 indicates that an unaddressed unit might be failing.

A unit attached to the same IOP, other than the addressed unit identified by FI00882, is the failing item.

FI00884

FI00884 indicates that any unit attached to the IOP might be the failing item.

See FI00882 for the list of possible units.

FI01040

FI01040 indicates that you have an OptiConnect system, and the error is on an iSeries or System i[®] server that is connected to it.

FI01101

FI01101 indicates that the addressed IOA card on the I/O processor is the failing item.

Perform the following:

1. Determine the address of the IOA card. See The system reference code format description.
2. Determine the location of the IOA card.
3. Exchange the failing device. Use the device type to determine the part.

FI01103

FI01103 indicates that an attached IOA card is the failing item.

Perform MABIP55 to isolate the failing IOA.

FI01104

FI01104 indicates that an attached IOA card is the failing item.

Perform MABIP55 to isolate the failing IOA.

FI01105

FI01105 indicates that the addressed storage device is the failing item.

Perform the following steps:

1. Is the device location information available in the Service Action Log?
 - **No:** Continue with the next step.
 - **Yes:** Exchange the failing item. See the disk unit recovery procedures.
2. Find the IOP address and the device address. See The system reference code format description.
3. To determine the location of the I/O processor card, see Part locations and location codes. Then find:
 - The IOP card location identified by the direct select address.
 - The addressed storage device location identified by the device address.
4. Exchange the failing device. Use the device type to determine the part.

FI01106

FI01106 indicates that a storage device other than the addressed storage device is the failing item.

1. See FI01105 to find the addressed device. The failing item could be any device with the same IOP address and I/O (SCSI) bus number but with a different device unit number.

2. If the reference code that called out this failing item does not have a problem analysis procedure, perform IOPIP16 to isolate the possible failing device.

FI01107

FI01107 indicates that any storage device attached to the I/O (SCSI) bus of this IOP may be the failing item.

Perform the following:

1. Find the IOP address. See The system reference code format description.
2. To determine the location of the I/O processor card, see Part locations and location codes.
The unit reference code indicates the I/O (SCSI) bus that has the problem:
 - URC 3020, 3100 -- I/O Bus 0
 - URC 3021, 3101 -- I/O Bus 1
 - URC 3022, 3102 -- I/O Bus 2
 - URC 3023, 3103 -- I/O Bus 3
 - Any Other URC -- Any I/O bus on the I/O card
3. See Part locations and location codes to find the diagram of the system unit or the expansion unit and find:
 - The IOP card location identified by the direct select address.
 - All the storage devices on the same I/O (SCSI) bus.
4. Exchange the failing device. Use the device type to determine the part.
5. If the reference code that called out this failing item does not have a problem analysis procedure, perform IOPIP16 to isolate the possible failing device.

FI01108

FI01108 indicates that the I/O (SCSI) bus or power cable is the failing item.

See FI01140 and FI01141.

FI01109

FI01109 indicates that the backplane or a connection to the backplane might be failing.

See the symbolic FRU BACKPLN.

FI01110

FI01110 indicates that the diskette unit is the failing item.

Use the diskette device type to determine the part.

Note the device type and refer to Finding parts, locations, and addresses to determine the FRU part number to replace.

FI01112

FI01112 indicates that the active IOP is the failing item.

1. Find the IOP address. See The system reference code format description.
2. To determine the location of the I/O processor card, see Part locations and location codes and get the type from the card in that location or address.
3. Use the IOP type to determine the part to replace.

FI01117

FI01117 indicates that any IOA, card, cable, or device attached to the IOP may be the failing item.

1. Find the IOP address. See The system reference code format description.
2. To determine the location of the I/O processor card, see Part locations and location codes.
3. Identify the IOAs, cards, cables, and devices attached to the IOP found in the preceding steps.
4. Exchange the IOAs, cards, cables, and devices attached to the IOP one at a time until you have corrected the problem.

FI01119

FI01119 indicates that the backplane or a connection to the backplane might be failing.

See the symbolic FRU BACKPLN.

FI01121

FI01121 is not supported on these models. Continue with the next FRU in the list.

FI01130

FI01130 indicates that the disk unit is the failing item.

Find the disk unit type number in Finding parts, locations, and addresses to determine the part number.

FI01131

FI01131 is not supported on these models. Continue with the next FRU in the list.

FI01132

FI01132 is not supported on these models. Continue with the next FRU in the list.

FI01140

FI01140 indicates that the I/O (SCSI) bus cable is the failing item.

Perform the following steps:

1. Are there external devices attached?
 - **No:** Continue with the next step.
 - **Yes:** Choose from the following options:
 - For SCSI attached external devices, see See the symbolic FRU EXTSCSI.
 - For Fibre Channel attached external devices, see FCCABLE.
2. Find the IOP address. See The system reference code format description.
3. To determine the location of the I/O processor card, see Part locations and location codes and get the type from the card in that location or address.
4. Exchange the failing item associated with the IOP address.

Note: Any of the SCSI cables or backplanes between the IOA and the device could be the failing item.

FI01141

FI01141 indicates that a loss of power to an IOP, to an internal device, or to an external device may have occurred.

Perform the following steps:

1. Are 0000 xxxx, 1xxx xxxx, or A6xx 698x SRCs displayed on the control panel?

- **No:** Continue with the next step.
 - **Yes:** Use the SRC displayed on the control panel to diagnose the problem.
2. Did the SRC that directed you to this FI code involve an externally attached device or an IOP with an externally attached device?
 - **No:** Continue with the next step.
 - **Yes:** Verify that there is no obvious problem with power to the device. If you suspect a power problem with the device, go to the service information for that external device.
 3. The power supply cables or connections to internal disk units, tape units, or optical storage units may be the failing item. For part numbers, see Finding parts, locations, and addresses.

FI01201

FI01201 indicates that the disk drive is the failing item.

Use the disk unit type number to determine the part number.

Note the device type and refer to Finding parts, locations, and addresses to determine the FRU part number to replace.

FI01202

FI01202 indicates that the disk drive is the failing item.

See FI01201.

FI01203

FI01203 indicates that the disk drive is the failing item.

See FI01201.

FI02092

FI02092 indicates that the load source for an alternate IPL or the interface to the load source is the failing item.

See FI00092.

FI02112

FI02112 indicates that the addressed storage device is the failing item.

Perform the following steps:

1. Is the device location information available in the Service Action Log?
 - **No: Continue with the next step.**
 - **Yes: Exchange the failing item.**
2. Find the IOP address and the device address. See The system reference code format description.
3. To determine the location of the I/O processor card, see Part locations and location codes. Then, find:
 - The IOP card location identified by the direct select address.
 - The addressed storage device location identified by the device address.
4. Exchange the failing device. Possible failing addressed devices include disk, tape, optical, device backplane, or Auxiliary Cache IOA. Use the device type to determine the part.

Symbolic FRUs

This information is a list of symbolic field replaceable units (FRUs).

The procedures in this topic are listed alphabetically.

ACMODUL

Your server has suffered a power loss. This procedure will help you determine the source of the power loss condition that brought you here.

If the system or expansion unit that exhibited the power loss powers on normally, or stays powered on after an ac power failure, replacement of parts might not be needed. Power failures can be caused by brown outs, building or room power receptacle power loss, loose or disconnected power cords, or possible hardware conditions.

1. Is the failing unit configured with a redundant power supply option (or dual line cord feature)?
 - **No:** Continue with the next step.
 - **Yes:** A service representative must perform power isolation procedure PWR1911 which is located in the service guide for the system unit.
2. Are all the units powered on?
 - **Yes:** This error might have been caused by an ac power outage. If the system will power on without an error, no parts need to be replaced. **This ends the procedure.**
 - **No:** On the unit that does not power on, verify that the power outlet is supplying the correct power for the unit. Also, ensure that both ends of the power cord (from the unit that does not power on) are connected correctly and securely. If you find a problem, correct the problem, **this ends this procedure.**

If you cannot find the problem, the following steps must be performed by a trained service representative:

- Use a multimeter to measure the voltage at the system end of the power cord.
- Is the voltage correct, refer to the following table?

Model or expansion unit	Correct voltage
5796, 7314-G30, or 8204-E8A, 9409-M50	200V to 240V AC or 200V to 220V DC
8203-E4A, 9117-MMA, 9406-MMA, 9407-M15, 9408-M25, 5802, 7311-D11, or 7311-D20	200V to 240V AC

- **Yes:** Continue with the next step.
- **No:** Go to the step 4.

3. Replace the failing power supply, use the following table to determine the part number for the field replaceable unit (FRU):

CCIN or FFC	Type and model	Part number	Description	Location code
	9406-MMA, 9117-MMA	See Finding parts, locations, and addresses.	Power supply 1	Un-E1
	9406-MMA, 9117-MMA	See Finding parts, locations, and addresses.	Power supply 2	Un-E2
	8203-E4A, 9407-M15, 9408-M25	44V4195	Power supply 1 (ac supply)	Un-E1
	8203-E4A, 9407-M15, 9408-M25	44V4195	Power supply 2 (ac supply)	Un-E2

	8204-E8A, 9409-M50	44V3559	Power supply 1 (ac supply)	Un-E1
	8204-E8A, 9409-M50	44V3559	Power supply 2 (ac supply)	Un-E2
	8204-E8A, 9409-M50	42R6607	Power supply 1 (dc supply)	Un-E1
	8204-E8A, 9409-M50	42R6607	Power supply 2 (dc supply)	Un-E2
	5790, 7311-D11	22R3958	Power supply 1	Un-E1
	5790, 7311-D11	22R3958	Power supply 2	Un-E2
	0595, 5095, 7311-D20	39J2781	Power supply 1	Un-E1
	0595, 5095, 7311-D20	39J2781	Power supply 2	Un-E2
	5796, 7314-G30	42R4491	Power supply 1	Un-E1
	5796, 7314-G30	42R4491	Power supply 2	Un-E2
	5094	39J5273	Power supply 0	Un-P00
	5094	39J5273	Power supply 1	Un-P01
	5094	39J5273	Power supply 2	Un-P02
	5094	39J5273	Power supply 3	Un-P03
	5094	39J5171	AC module A01	Un-A01
	5094	39J5171	AC module A02	Un-A02
	5802	See Finding parts, locations, and addresses.	Power supply 1	Un-E1
	5802	See Finding parts, locations, and addresses.	Power supply 2	Un-E2

4. Perform the following:

- a. Disconnect the power cord from the customer's power outlet.
- b. Use a multimeter to measure the voltage at the customer's power outlet.

Is the voltage correct?

- **Yes:** Exchange the failing power cord. **This ends the procedure.**
- **No:** Perform the following:
 - 1) Inform the customer that the voltage at the power outlet is not correct.
 - 2) After the voltage at the power outlet is correct, reconnect the power cord to the power outlet. **This ends the procedure.**

AIRMOVR

A fan might be failing. Before replacing any field replaceable units (FRUs), ensure the fans and fan trays are fully seated into the fan connectors and that all cables are seated correctly.

Replace the FRUs in order, one at a time, starting with the primary unit and then the secondary units. Use the following table to determine the failing fan and location.

Unit reference code, CCIN, or FFC	Type and model	Part number	Description	Location code
7610, 7611	8203-E4A, 9407-M15, 9408-M25	39J4517	Blower assembly	Un-A4

7620, 7621	8203-E4A, 9407-M15, 9408-M25	39J4517	Blower assembly	Un-A3
7630, 7631	8203-E4A, 9407-M15, 9408-M25	39J4517	Blower assembly	Un-A2
7640, 7641	8203-E4A, 9407-M15, 9408-M25	39J4517	Blower assembly	Un-A1
7610, 7611	8204-E8A, 9409-M50	44V3454	Processor cooling fan	Un-A1
7620, 7621	8204-E8A, 9409-M50	44V3454	Processor cooling fan	Un-A2
7630, 7631	8204-E8A, 9409-M50	44V3454	Processor cooling fan	Un-A3
7640, 7641	8204-E8A, 9409-M50	44V3454	Processor cooling fan	Un-A4
7610, 7611	9406-MMA, 9117-MMA	39J0859	Fan assembly	Un-A1
7620, 7621	9406-MMA, 9117-MMA	39J0859	Fan assembly	Un-A2
7650, 7651	5790, 7311-D11	03N6069	Fan assembly	Un-A1
7610, 7611	0595, 5095, 7310-D20	39J1176	Fan assembly	Un-A1
7620, 7621	0595, 5095, 7310-D20	39J1176	Fan assembly	Un-A2
7630, 7631	0595, 5095, 7310-D20	39J1176	Fan assembly	Un-A3
7640, 7641	0595, 5095, 7310-D20	39J1176	Fan assembly	Un-A4
7610, 7611	5094	39J5235	Air-moving device (fan)	Un-B01
7620, 7621	5094	39J5235	Air-moving device (fan)	Un-B02
7600	5802	See Finding parts, locations, and addresses.	Air-moving device (fan)	Un-E1-A1
7601	5802	See Finding parts, locations, and addresses.	Air-moving device (fan)	Un-E1-A2
7602	5802	See Finding parts, locations, and addresses.	Air-moving device (fan)	Un-E2-A1
7603	5802	See Finding parts, locations, and addresses.	Air-moving device (fan)	Un-E2-A2

AJDG301

Licensed Internal Code is the failing item. Look for PTFs associated with the reference code and have the customer apply them.

AJDGP01

Licensed Internal Code is the failing item. Look for PTFs associated with the reference code and have the customer apply them.

AJEDA00

Licensed Internal Code is the failing item. Look for PTFs associated with the reference code and have the customer apply them.

AJEGP01

Licensed Internal Code is the failing item. Look for PTFs associated with the reference code and have the customer apply them.

AJEQU00

Licensed Internal Code is the failing item. Look for PTFs associated with the reference code and have the customer apply them.

AJGAM01

Licensed Internal Code is the failing item. Look for PTFs associated with the reference code and have the customer apply them.

AJGDF01

Licensed Internal Code is the failing item. Look for PTFs associated with the reference code and have the customer apply them.

AJGFN00

Licensed Internal Code is the failing item. Look for PTFs associated with the reference code and have the customer apply them.

AJGJ601

Licensed Internal Code is the failing item. Look for PTFs associated with the reference code and have the customer apply them.

AJGJQ01

Licensed Internal Code is the failing item. Look for PTFs associated with the reference code and have the customer apply them.

AJGLD01

Licensed Internal Code is the failing item. Look for PTFs associated with the reference code and have the customer apply them.

AJGW701

Licensed Internal Code is the failing item. Look for PTFs associated with the reference code and have the customer apply them.

AJLAF01

Licensed Internal Code is the failing item. Look for PTFs associated with the reference code and have the customer apply them.

AJLAG01

Licensed Internal Code is the failing item. Look for PTFs associated with the reference code and have the customer apply them.

AJLYC01

Licensed Internal Code is the failing item. Look for PTFs associated with the reference code and have the customer apply them.

AJLYD01

Licensed Internal Code is the failing item. Look for PTFs associated with the reference code and have the customer apply them.

AJSDJ01

Licensed Internal Code is the failing item. Look for PTFs associated with the reference code and have the customer apply them.

ALTMANL

An Integrated xSeries server (IXS) for iSeries service call might be needed to fix the problem on the IXS.

Note: An error condition is indicated by the blinking frame ID on the IXS card. When an error occurs, it can take up to ten minutes for the frame ID to start blinking, and up to one minute (after the error is reset) for the frame ID to stop blinking.

Use the following table to find instructions for the reference code you are experiencing

Table 1. Table 1. IXS reference codes and instructions

Reference code	Instructions
1xxx-8910	<p>Check the system error light (amber exclamation point) on the IXS panel.</p> <ul style="list-style-type: none">• If the system error light is on, call the customer's IXS service provider.• If the system error light is not on, see TWRCARD. <p>Note: Removal of the ac line cord on the IXS unit is required to reset the flashing frame-indicating LEDs on the tower card.</p>
1xxx-8920	<p>Call the customer's IXS service provider. Note: Removal of the AC line cord on the IXS unit is required to reset the flashing frame-indicating LEDs on the tower card.</p>

This ends the procedure.

AMBTEMP

The system detected a room ambient over-temperature warning or fault.

1. Is the room temperature less than 35 degrees C or 95 degrees F?
 - **No:** Notify the customer. The customer must bring the room temperature within normal range. Continue with the next step.
 - **Yes:** Continue with the next step.
2. Are the system front and rear doors free of obstructions?
 - **No:** Notify the customer. The system must be free of obstructions for proper air flow. Continue with the next step.
 - **Yes:** Continue with the next step.
3. If applicable, do all the positions in the processor subsystem contain processors or fillers?
 - **Yes:** Continue with the next step.
 - **No:** Fill any open positions with processors or fillers. **This ends the procedure.**
4. Do all the power supply positions contain power supplies or fillers?
 - **Yes:** Continue with the next step.
 - **No:** Fill any open positions with supplies or fan books. **This ends the procedure.**

5. Are you working with reference code 7201?

- **Yes:** This indicates that the room temperature is too high. The customer must bring the room temperature to less than 35 degrees C or 95 degrees F. If the room temperature is less than 35 degrees C or 95 degrees F, continue with the next step. **This ends the procedure.**
- **No:** Continue with the next step.

6. Perform the following:

- **For model 8203-E4A, 9407-M15, 9408-M25,** exchange the control panel. Use the following table to determine the part number for the field replaceable unit (FRU). Then continue with the next step.

CCIN or FFC	Type and model	Part number	Description	Location code
	8203-E4A, 9407-M15, 9408-M25	10N9737	Control (Operator) panel	Un-D1

- **For model 8204-E8A, 9409-M50,** exchange the control panel. Use the following table to determine the part number for the field replaceable unit (FRU). Then continue with the next step.

CCIN or FFC	Type and model	Part number	Description	Location code
	8204-E8A, 9409-M50	42R5505	Operator panel	Un-D1

- **For model 9406-MMA or 9117-MMA,** exchange processor 1 and processor 2, one at a time, until either the problem is resolved or you have replaced both processors. Then continue with the next step.

For each unit, starting with the primary unit and then the secondary units, use the following table to determine the part number for the field replaceable unit (FRU):

CCIN or FFC	Type and model	Part number	Description	Location code
	9406-MMA, 9117-MMA	10N9146	3.5 GHz POWER6 - 2 core processor book	Un-P2-C1
	9406-MMA, 9117-MMA	10N9144	4.2 GHz POWER6 -2 core processor book	Un-P2-C1
	9406-MMA, 9117-MMA	10N9139	4.7 GHz POWER6 -2 core processor card	Un-P2-C1

- **For the 5802 expansion unit,** replace the power supply at location Un-E1. If this does not resolve the problem, replace the power supply at location Un-E2. Use the following table to determine the part number for the field replaceable unit (FRU). Then continue with the next step.

CCIN or FFC	Type and model	Part number	Description	Location code
	5802	See Finding parts, locations, and addresses.	Power supply	Un-E1, Un-E2

7. After each FRU is exchanged, is the error code that sent you to this procedure still reported?

- **No:** The problem has been corrected. **This ends the procedure.**
- **Yes:** Replace the next FRU on the list. If all FRUs on the list have been replaced, call your next level of support. **This ends the procedure.**

AMBTMP1

Ambient air temperature is too high for optimal performance.

Air used for cooling the unit is above the temperature at which the unit is designed to run at maximum performance. The following checks will help determine the problem:

- If the room temperature is above the specified range for the unit reporting this problem, then take steps to lower the room temperature.
- If the air being drawn into the unit is above the specified range, either move the unit to a place where the air is within range, or take steps to reduce the temperature of the air surrounding the unit. This can be accomplished by moving the source of the air that is too warm.
- If the temperature of the air at the unit's air intake is within the range specified contact your next level of support.

AMBTMP2

Ambient air temperature is back within range.

Ambient air temperature entering the system unit has returned to the nominal operational range for maximum performance. This message and/or symbolic FRU results when the temperature of the air entering the unit was previously reported to be above the unit's specified range. This message and/or symbolic FRU is issued when the unit detects that the ambient air temperature has dropped to within the specified range for maximum performance. No action is necessary.

ANYBRDG

Find the location of the card reporting the problem and its corresponding PCI bridge set. Any cable, card, or card enclosure -- not necessarily the card that reported the problem -- connected to the PCI bridge set may be causing the problem.

ANYBUS

Any cable, card, or card enclosure may be causing an IOP-detected bus error, although the IOP that is reporting the problem may not be causing the problem.

ANYFC

Any IOA, hub, gateway, or device attached to the same fibre channel interface may be failing.

ANYPROC

The failing component is one of the system processors.

For each unit, starting with the primary unit and then the secondary units, use the following table to determine the part number for the field replaceable unit (FRU):

CCIN or FFC	Type and model	Part number	Description	Location code
	8203-E4A, 9407-M15, 9408-M25	42R7898	System backplane	U <i>n</i> -P1-C <i>x</i>
53E1	8204-E8A, 9409-M50	10N9377	GHz 4.2 GHz POWER6, 2 Core Processor Card (FC4966)	U <i>n</i> -P1-C <i>x</i>
53E2	8204-E8A, 9409-M50	10N9380	GHz 4.7 GHz POWER6, 2 Core Processor Card (FC4967)	U <i>n</i> -P1-C <i>x</i>
	9406-MMA, 9117-MMA	10N9146	3.5 GHz POWER6, 2 core processor book	U <i>n</i> -P2-C <i>x</i>
	9406-MMA, 9117-MMA	10N9144	4.2 GHz POWER6, 2 core processor book	U <i>n</i> -P2-C <i>x</i>
	9406-MMA, 9117-MMA	10N9139	4.7 GHz POWER6, 2 core processor book	U <i>n</i> -P2-C <i>x</i>

AS4NTDD

The Windows[®] server application processor device driver might be causing the problem.

Refer to the "Windows environment on iSeries[™]" topic in the iSeries Information Center at <http://publib.boulder.ibm.com/infocenter/series/v5r4/index.jsp?topic=/rzahq/rzahqntspo.htm>, or contact your next level of support for assistance.

AUXCBL

Replace the SCSI cable that connects the auxiliary cache I/O adapter to the storage I/O adapter.

1. Find the location of the auxiliary cache I/O adapter:
 - a. Determine the address of the auxiliary cache I/O adapter. See The system reference code format description.
 - b. Determine the location of the auxiliary cache I/O adapter. See Part locations and location codes for the model on which you are working.
2. Replace the SCSI cable that connects the auxiliary cache I/O adapter to the storage I/O adapter. See Finding parts, locations, and addresses for cable part number information.

This ends the procedure.

Note: In order to replace the SCSI cable concurrently, you **must** use concurrent maintenance to power off the auxiliary cache I/O adapter. Replace the cable and then use concurrent maintenance to power on the auxiliary cache I/O adapter. **Do NOT replace the cable when both adapters are powered on.**

AUXIOA

Replace the auxiliary I/O adapter.

Use the location information in the Service Action Log, if it is available. If the location information is not available, determine the address of the auxiliary cache I/O adapter. See The system reference code format description. Use the address to find the location. See Part locations and location codes.

BACKPLN

A backplane or a connection to the backplane might be failing. Use this procedure to identify which backplane might be failing.

Note: Before replacing any parts, verify the connections to the backplane.

1. Were you sent here by a power reference code (1xxxxxx)?
 - **No:** Continue with the next step.
 - **Yes:** Go to SYSBKPL. **This ends the procedure.**
2. Determine the location of the device by performing the following:
 - a. Use the location information in the error log if it is available. If no location information for the device is available, use the location information for the I/O adapter instead.
 - b. If no location information is available for either the device or the I/O adapter, find the address of the device or I/O adapter (see The system reference code format description. Use the address to find the location. See Part locations and location codes.
 - c. Any backplane connecting the device or I/O adapter might be the cause of the problem. Use the location code to determine in which unit the device, cable, and the connected backplane are located. Then use the following table to determine the part number for the field replaceable unit (FRU):

CCIN or FFC	Type and model	Part number	Description	Location code
	8203-E4A, 9407-M15, 9408-M25	42R7898	System backplane	Un-P1
	8204-E8A, 9409-M50	10N9369	System backplane	Un-P1
	9406-MMA, 9117-MMA	42R7352	I/O backplane	Un-P1
28BB	5790, 7311-D11	80P6626	I/O backplane	Un-P1
	0595, 5095, 7311-D20	39J0515	I/O backplane	Un-P1
520C	5796, 7314-G30	See Finding parts, locations, and addresses.	I/O backplane	Un-P1
28B7	5094	39J3058	I/O backplane	Un-CB1

This ends the procedure.

BATCHGR

A battery power unit charger is the failing item.

Exchange the battery power unit charger. See the table below.

Note: When a part number is displayed on the control panel of a system or expansion unit, replace that part first.

Use the following table to determine the part number for the field replaceable unit (FRU):

CCIN or FFC	Type and model	Part number	Description	Location code
	5074, 5079	97H7316	Battery power unit charger	U n-A01

This ends the procedure.

BATRY

A battery is the failing item.

Exchange the battery. See the table below.

Note: When a part number is displayed on the control panel of a system or expansion unit, replace that part first.

Use the following table to determine the part number for the field replaceable unit (FRU):

CCIN or FFC	Type and model	Part number	Description	Location code
	5074, 5079	97H7318	Battery pack	U n-T0 n

This ends the procedure.

BPC

There is an ethernet communications failure on one of the BPCs, or a fault on one of the BPCs.

1. Is the SRC 1xxx8720 or 1xxx8721?

- **No:** Continue with the next step.

- **Yes:**

For 575 (9125-F2A): Ensure all HubA (T5) ethernet cables on the service processors are routed to the same BPA on one side of the system and HubB (T6) cables are routed to the other BPA. If a problem is found, correct it. **This ends the procedure.**

For 595 (9119-FHA): Ensure that the following Ethernet connections are cabled correctly:

On the SC (system controller) at Un-P1-C2: ent0 is connected to J05 on BPH-A, and ent1 is connected to J05 on BPH-B. If a problem is found, correct it. **This ends the procedure.**

On the SC (system controller) at Un-P1-C5: ent0 is connected to J06 on BPH-A, and ent1 is connected to J06 on BPH-B. If a problem is found, correct it. This ends the procedure.

Communications problems will result if cabling is mixed during repair or installation.

If the Ethernet cabling is correct, continue to the next item in the FRU list. **This ends the procedure.**

2. Is the SRC 1xxx8724 or 8725? **No:** Continue with the next step. **Yes:** If the SRC is 1xxx8724, replace BPC A (front). If the SRC is 1xxx8725, replace BPC B (rear). **This ends the procedure.**
3. Use the following table to perform the appropriate action for the SRC you are working

SRC	Replace this FRU	Link to locations information
1xxx8740	BPC A (front)	Part locations and location codes
1xxx8741	BPC B (rear)	

This ends the procedure.

BPCHANG

The system is stopped on one of the base system integrated controller checkpoints.

If the system hangs on one of the base system integrated controller checkpoints, do the following:

1. Remove the AC cord, then reattach it to the system.
2. Watch the control panel display. If 01 appears in the upper left hand corner of the display, power on the system.

If the system continues to hang on a base system controller checkpoint, replace the backplane in the system unit that contains integrated I/O controllers. Use the following table to determine the part number for the field replaceable unit (FRU):

CCIN or FFC	Type and model	Part number	Description	Location code
	8203-E4A, 9407-M15, 9408-M25	42R7898	System backplane	U n-P1
	8204-E8A, 9409-M50	10N9369	System backplane	U n-P1
	9406-MMA, 9117-MMA	42R7352	I/O backplane	U n-P1

This ends this procedure

BRDGSET

The multi-adapter bridge hardware is having a problem with one or more PCI cards or adapters in the PCI bridge set, but the exact card or adapter cannot be identified.

The problem may be with a card, a card slot, or an embedded adapter. The PCI bridge set is indicated by the Direct Select Address (DSA) in word 7 of the reference code. This symbolic FRU only appears in the serviceable event user interface when the LIC could not determine which PCI bridge set has the problem.

1. Are you working from a serviceable event user interface of an operating system, service processor, or the HMC that is giving you a card position or list of card positions for this FRU?
 - **Yes:** Go to step 5. **Note:** When there is a list of locations in this FRU's location code, the card locations will be separated by commas. A range of card positions will show the starting card position, a colon, and the ending card position.
 - **No:** Perform the following:
 - Determine the location of the cards in the group using the DSA. Record the DSA (word 7 of the reference code) from the user interface you are using.
 - Locate the cards specified in the DSA by performing isolation procedure MABIP53. Return here and continue with the next step after locating the card(s).
2. Did isolation procedure MABIP53 identify a single card location?
 - **Yes:** This is the location of the failing item. Go to step 5.
 - **No:** Perform the following (refer to the table below):
 - a. Remove all of the adapter and/or IOP cards in the locations that are identified in the given range of card slots. Do not remove any FRUs with embedded adapters, only FRUs in PCI card slots.
 - b. Replace each card one at a time. **Note:** For IBM i^(R) adapters controlled by IOPs, replace the IOP before any of the adapters. Power on the unit after you replace each card until either the problem reappears or you have replaced each card. Then continue with the next step.
3. Did the problem reappear?
 - **Yes:** The last card that you replaced before the problem reappeared is the failing item. **This ends the procedure.**
 - **No:** Continue with the next step.
4. Did isolation procedure MABIP53 identify a FRU with embedded adapters?
 - **Yes:** The problem is in the FRU with the embedded adapter. Continue with the next step and exchange that FRU using the following table.
 - **No:** The problem may be intermittent. Contact your next level of support. **This ends the procedure.**
5. For each unit, starting with the primary unit and then the secondary units, use the following table to locate and replace the failing item(s):

CCIN or FFC	Type and model	Part number	Description	Location code
	9406-MMA, 9117-MMA	42R7352	I/O backplane, PCI bridge set 1	Un-P1
	9406-MMA, 9117-MMA	42R7352	I/O backplane, PCI bridge set 2	Un-P1, Un-P1-C1, Un-P1-C2
	9406-MMA, 9117-MMA	42R7352	I/O backplane, PCI bridge set 3	Un-P1, Un-P1-C3, Un-P1-C4, Un-P1-C5, Un-P1-C6
	5790, 7311-D11	80P6626	I/O backplane, PCI bridge set 1	Un-P1, Un-P1-C1, Un-P1-C2, Un-P1-C3
	5790, 7311-D11	80P6626	I/O backplane, PCI bridge set 2	Un-P1, Un-P1-C4, Un-P1-C5, Un-P1-C6

CCIN or FFC	Type and model	Part number	Description	Location code
	0595, 5095, 7311-D20	39J0515	I/O backplane, PCI bridge set 1	Un-P1, Un-P1-C01, Un-P1-C02, Un-P1-C03, Un-P1-C04
	0595, 5095, 7311-D20	39J0515	I/O backplane, PCI bridge set 2	Un-P1, Un-P1-C06, Un-P1-C07, Un-P1-C08
	5796, 7314-G30	See Finding parts, locations, and addresses.	I/O backplane, PCI bridge set 1	Un-P1, Un-P1-C1, Un-P1-C2, Un-P1-C3
	5796, 7314-G30	See Finding parts, locations, and addresses.	I/O backplane, PCI bridge set 2	Un-P1, Un-P1-C4, Un-P1-C5, Un-P1-C6
	5094	39J3058	I/O backplane, PCI bridge set 1	Un-CB1-C01, Un-CB1-C02, Un-CB1-C03, Un-CB1-C04
	5094	39J3058	I/O backplane, PCI bridge set 2	Un-CB1-C05, Un-CB1-C06, Un-CB1-C07, Un-CB1-C08, Un-CB1-C09
	5094	39J3058	I/O backplane, PCI bridge set 3	Un-CB1-C11, Un-CB1-C12, Un-CB1-C13, Un-CB1-C14, Un-CB1-C15

BRDGST1

The multi-adapter bridge hardware is having a problem with one or more PCI cards or adapters in the first PCI bridge set in the enclosure, but the exact card or adapter cannot be identified.

The problem can be with a card, a card slot, or an embedded adapter. The PCI bridge set is indicated by the Direct Select Address (DSA) in word 7 of the reference code.

- Are you working from a serviceable event user interface of an operating system, service processor, or the HMC and there is a card position or list of card positions given for this FRU?
 - Yes:** Then the position(s) given is the location of the failing component(s). When there is a list of locations in this FRU's location code, the card locations will be separated by commas. A range of card positions will show the starting card position, a colon, and the ending card position. Go to step 5.
 - No:** Perform the following:
 - Determine the location of the cards in the group using the DSA. Record the DSA, which is word 7 of the reference code, from the user interface you are using.
 - Locate the cards specified in the DSA by performing isolation procedure MABIP53. Return here and continue with the next step after locating the card(s).
- Were you able to identify a single card position by performing MABIP53?
 - Yes:** This is the location of the failing item. Go to step 5.
 - No:** Continue with the next step.
- Perform the following, referring to the removal and replacement procedures for each FRU location you determined:

- a. Remove all of the adapter and/or IOP cards in the locations that are identified in the given range of card slots. Do not remove any FRUs with embedded adapters, only FRUs in PCI card slots.
 - b. Replace each card one at a time. **Note:** For IBM i^(R) adapters controlled by IOPs, replace the IOP before any of the adapters. Power on the unit after you replace each card until either the problem reappears or you have replaced each card.
 - c. Did the problem reappear?
 - **Yes:** The last card that you replaced before the problem appeared again is the failing item. **This ends the procedure.**
 - **No:** Continue with the next step.
4. Did you identify a FRU with embedded adapters when performing isolation procedure MABIP53?
 - **Yes:** The problem is in the FRU with the embedded adapter. Continue with the next step and exchange that FRU.
 - **No:** The problem may be intermittent. Contact your next level of support. **This ends the procedure.**
 5. For each unit, starting with the primary unit and then the secondary units, use the following table to locate and replace the failing item(s):

CCIN or FFC	Type and model	Part number	Description	Location code
	9406-MMA, 9117-MMA	42R7352	I/O backplane, PCI bridge set 1	Un-P1
	5790, 7311-D11	80P6626	I/O backplane, PCI bridge set 1	Un-P1, Un-P1-C1, Un-P1-C2, Un-P1-C3
	0595, 5095, 7311-D20	39J0515	I/O backplane, PCI bridge set 1	Un-P1, Un-P1-C01, Un-P1-C02, Un-P1-C03, Un-P1-C04
	5796, 7311-G30	See Finding parts, locations, and addresses.	I/O backplane, PCI bridge set 1	Un-P1, Un-P1-C1, Un-P1-C2, Un-P1-C3
	5094	39J3058	I/O backplane, PCI bridge set 1	Un-CB1-C01, Un-CB1-C02, Un-CB1-C03, Un-CB1-C04

This ends the procedure.

BRDGST2

PCI I/O card group in the second PCI bridge set (middle adapter card range when there are three PCI bridge sets and high adapter card range when there are two PCI bridge sets), IOAs and/or IOPs.

The multi-adapter bridge hardware is having a problem with one or more PCI cards or adapters in the second PCI bridge set in the enclosure, but the exact card or adapter cannot be identified. The problem can be with a card, a card slot, or an embedded adapter. The PCI bridge set is indicated by the Direct Select Address (DSA) in word 7 of the reference code.

1. Are you working from a serviceable event user interface of an operating system, service processor, or the HMC and there is a card position or list of card positions given for this FRU?
 - **Yes:** Then the position(s) given is the location of the failing component(s). When there is a list of locations in this FRU's location code, the card locations will be separated by commas. A range of card positions will show the starting card position, a colon, and the ending card position. Go to step 5.
 - **No:** Perform the following:

- a. Determine the location of the cards in the group using the DSA. Record the DSA, which is word 7 of the reference code, from the user interface you are using.
 - b. Locate the cards specified in the DSA by performing isolation procedure MABIP53. Return here and continue with the next step after locating the card(s).
2. Were you able to identify a single card position by performing MABIP53?
 - **Yes:** This is the location of the failing item. Go to step 5.
 - **No:** Continue with the next step.
 3. Perform the following, referring to the remove and replace procedures for each FRU location you determined:
 - a. Remove all of the adapter and/or IOP cards in the locations that are identified in the given range of card slots. Do not remove any FRUs with embedded adapters, only FRUs in PCI card slots.
 - b. Replace each card one at a time.

Note: For IBM i adapters controlled by IOPs, replace the IOP before any of the adapters. Power on the unit after you replace each card until either the problem reappears or you have replaced each card.
 - c. Did the problem reappear?
 - **Yes:** The last card that you replaced before the problem appeared again is the failing item. **This ends the procedure.**
 - **No:** Continue with the next step.
 4. Did you identify a FRU with embedded adapters when performing isolation procedure MABIP53?
 - **Yes:** The problem is in the FRU with the embedded adapter. Continue with the next step and exchange that FRU.
 - **No:** The problem may be intermittent. Contact your next level of support. **This ends the procedure.**
 5. For each unit, starting with the primary unit and then the secondary units, use the links in the table below to locate and replace the failing item(s).

CCIN or FFC	Type and model	Part number	Description	Location code
	9406-MMA, 9117-MMA	42R7352	I/O backplane, PCI bridge set 2	Un-P1, Un-P1-C1, Un-P1-C2
	5790, 7311-D11	80P6626	I/O backplane, PCI bridge set 2	Un-P1, Un-P1-C4, Un-P1-C5, Un-P1-C6
	0595, 5095, 7311-D20	39J0515	I/O backplane, PCI bridge set 2	Un-P1, Un-P1-C06, Un-P1-C07, Un-P1-C08
	5796, 7311-G30	See Finding parts, locations, and addresses.	I/O backplane, PCI bridge set 2	Un-P1, Un-P1-C4, Un-P1-C5, Un-P1-C6
	5094	39J3058	I/O backplane, PCI bridge set 2	Un-CB1-C05, Un-CB1-C06, Un-CB1-C07, Un-CB1-C08, Un-CB1-C09

This ends the procedure.

BRDGST3

PCI I/O card group in the third PCI bridge set (highest adapter card range), IOAs and/or IOPs.

The multi-adapter bridge hardware is having a problem with one or more PCI cards or adapters in the third PCI bridge set in the enclosure, but the exact card or adapter cannot be identified. The problem can be with a card, a card slot, or an embedded adapter. The PCI bridge set is indicated by the Direct Select Address (DSA) in word 7 of the reference code.

1. Are you working from a serviceable event user interface of an operating system, service processor, or the HMC, and there is a card position or list of card positions given for this FRU?
 - **Yes:** Then the position(s) given is the location of the failing component(s). When there is a list of locations in this FRU's location code, the card locations will be separated by commas. A range of card positions will show the starting card position, a colon, and the ending card position. Go to step 5.
 - **No:** Perform the following:
 - a. Determine the location of the cards in the group using the DSA. Record the DSA, which is word 7 of the reference code, from the user interface you are using.
 - b. Locate the cards specified in the DSA by performing isolation procedure MABIP53. Return here and continue with the next step after locating the card(s).
2. Were you able to identify a single card position by performing MABIP53?
 - **Yes:** This is the location of the failing item. Go to step 5.
 - **No:** Continue with the next step.
3. Perform the following, referring to the remove and replace procedures for each FRU location you determined:
 - a. Remove all of the adapter and/or IOP cards in the locations that are identified in the given range of card slots. Do not remove any FRUs with embedded adapters, only FRUs in PCI card slots.
 - b. Replace each card one at a time. **Note:** For IBM i adapters controlled by IOPs, replace the IOP before any of the adapters.
Power on the unit after you replace each card until either the problem reappears or you have replaced each card.
 - c. Did the problem reappear?
 - **Yes:** The last card that you replaced before the problem appeared again is the failing item. **This ends the procedure.**
 - **No:** Continue with the next step.
4. Did you identify a FRU with embedded adapters when performing MABIP53?
 - **Yes:** The problem is in the FRU with the embedded adapter. Continue with the next step and exchange that FRU.
 - **No:** The problem may be intermittent. Contact your next level of support. **This ends the procedure.**
5. For each unit, starting with the primary unit and then the secondary units, use the links in the following table below to locate and replace the failing item(s).

CCIN or FFC	Type and model	Part number	Description	Location code
	9406-MMA, 9117-MMA	42R7352	I/O backplane, PCI bridge set 3	U n-P1, U n-P1-C3, U n-P1-C4, U n-P1-C5, U n-P1-C6
	5094	39J3058	I/O backplane, PCI bridge set 3	U n-CB1-C11, U n-CB1-C12, U n-CB1-C13, U n-CB1-C14, U n-CB1-C15

This ends the procedure.

BSTWRPL

This symbolic FRU is no longer supported.

BUSVPD

This is the VPD (vital product data) for a PCI bus at the multi-adapter bridge end of the primary PCI bus.

1. Are you working from the serviceable event view and a card location is listed with this failing item?
 - **Yes:** Then the error is at that card location. Continue with the next step.
 - **No:** Perform the following:
 -
 - a. Record the bus number value (BBBB) from word 7 of the reference code (see Analyzing a RIO/HSL/12X or PCI bus reference code for help in determining the bus number).
 - b. Search for the bus number in the HMC's or operating system's resource and configuration interfaces, or in the system configuration listing, to determine which unit contains the failing item. Record the frame or unit type and then continue with the next step.
2. Use the following table to determine the appropriate service action.

Frame or unit containing the failing item	Go to this symbolic FRU
8203-E4A, 8204-E8A, 9117-MMA, 9406-MMA, 9407-M15, 9408-M25, 9409-M50	SYSBKPL
7311-D10 and 7311-D11	TWRPLNR
7311-D20	TWRPLNR
5094	TWRPLNR
5095, 0595	TWRBKPL
External xSeries [®] server	SIADPCD

CABLCONT

This symbolic FRU is used to show additional locations for the endpoints of cables.

This FRU appears in the serviceable event user interface of an operating system, service processor, or the HMC, and is associated with the cable FRU that precedes it in the list. The location code associated with this FRU is the location of another end of the same cable. Cable FRUs are shown in the display by listing the cable's part number or symbolic FRU first with the location code of one end of the cable. Each additional cable endpoint is represented as a "CBLCONT" FRU with a location code for another endpoint.

Note: If question marks (???) appear at the end of the location code, then the port could not be determined. Use the location code associated with the other end of the cable. If question marks appear for both port locations, use the isolation procedures suggested in the Description/Action column of the reference code table for this SRC.

CABLEH

There may be a problem with the cabling between the system controllers and the BPHs.

Attention:

- Before replacing any cables, ensure that the cables are properly routed and securely plugged.
 - If you are servicing a BPC and get a 1xxx 8720 or 8721 SRC for any BPC, ignore the error until you have the BPC powered on again.
1. Is the SRC 1xxx-8720 or 8721?
 - **Yes:** Continue with the next step.

- **No:** Go to step 3.
2. **Note:** If you are getting a 8720 or 8721 Refcode:
- On a 575 (9125-F2A):**
- Ensure all HubA (System P1-T5) ethernet cables on the Service Processors are routed to the same BPA on one side of the system and HubB (System P1-T6) cables are routed to the other BPA. If a problem is found, correct it. **This ends the procedure.**

For 590 and 595 (9119-FHA):

- Ensure that the following Ethernet connections are cabled correctly:
 - On the SC (system controller) at Un-P1-C2: ent0 is connected to J05 on BPH-A, and ent1 is connected to J05 on BPH-B. If a problem is found, correct it. **This ends the procedure.**
 - On the SC (system controller) at Un-P1-C5: ent0 is connected to J06 on BPH-A, and ent1 is connected to J06 on BPH-B. If a problem is found, correct it. **This ends the procedure.**

Communications problems will result if cabling is mixed during repair or installation.

Next, you will be measuring voltages on the BPR(s). If the SRC is 1xxx8720, you should measure the voltage on BPR-A (front). If the SRC is 1xxx8721, you should measure the voltage on BPR-B (rear). The test points are on the left side of BPR-1 and BPR-2.

Using the labeled test points on the face of the BPR, measure the voltages between the following:

- phase A and phase B
- phase B and phase C
- phase C and phase A

Are all of the meter readings greater than 180 V ac?

- **Yes:** Go to step 4.
 - **No:** Inform the customer that power voltage at the input to the BPR is either missing or too low and needs to be corrected. **This ends the procedure.**
3. Is the SRC 1xxx 8724 or 8725?
- **No:** Go to step 4.
 - **Yes:** SPCN is reporting a mismatch between the machine type/model/serial number (MTMS) of the frame and the MTMS stored in a BPC. Do the following:
 - a. verify that the Ethernet cabling going to and from both BPCs is correct (see step 2 above for instructions on checking the connections between the system controllers and the BPHs. If there is more than one frame, verify that the Ethernet cabling between the frames is correct. If a problem is found, correct it. **This ends the procedure.**
 - b. Verify that the IP addresses shown on the HMC are correct. If a problem is found, correct it. **This ends the procedure.**
 - c. If all of the Ethernet cables are connected correctly, continue to the next FRU in the FRU list. **This ends the procedure.**
4. Use the following table to perform the appropriate action for the SRC with which you are working.

SRC	Action	Link to locations information
1xxx1D04	Replace the cables between the front light strip and the service processors.	Part locations and location codes
1xxx1D05	Replace the cables between the rear light strip and the service processors.	
1xxx8731 1xxx8732 1xxx8733 1xxx8734	Verify that the cabling between the BPA, BPCs, BPH, and the system controllers. If a problem is found, correct it.	Part locations and location codes

CACHBAT

The cache battery pack may be failing.

1. Use the cache battery pack location information in the service action log (SAL) if it is available. If the location is not available, use the address of the storage IOA, see The system reference code format description to find the location code for the storage IOA.

Using the location code, see Part locations and location codes to identify the storage IOA.

2. Using the type number of the storage IOA at the location you found, determine the cache battery pack part number. **Note:** The 571F/575B combination storage and auxiliary cache IOA card set uses two card slot locations. The battery pack is located on the 575B side of the card set, regardless of the location found in the previous steps.
3. Replace the cache battery pack.

This ends the procedure.

CACHE

This symbolic FRU is no longer supported.

CAPACTY

The failing component is the VPD card.

After the part has been replaced and before powering on the system, make sure the system's Vital Product Data (VPD) is restored (see "Setting the system identifiers" in the service guide for the system, or see Programming vital product data). The system will not IPL unless the VPD information is programmed correctly.

Use the following table to determine the part number for the field replaceable unit (FRU):

CCIN or FFC	Type and model	Part number	Description	Location code
52AE	8204-E8A, 9409-M50	10N8696	VPD card	U <i>n</i> -P1-C9
528E	9406-MMA, 9117-MMA	80P5110	VPD card (on the primary unit or any of the secondary units)	U <i>n</i> -P1-T10

CARDFLT

Use this information to perform the appropriate action for the SRC you are working with.

1. Is the failing system a 9119-FHA?

NO: Continue to the next step.

YES: Use the following table to find the appropriate action for the SRC you are working with.

Table 1. 9119-FHA

SRC	Replace this FRU	Link to locations information
	1. System controller at Un-P1-C2 2. System controller at Un-P1-C5	Part locations and location codes
1xxx1D01	1. System controller at Un-P1-C5 2. System controller at Un-P1-C2	

	1. Clock card at Un-P1-C3 2. Clock card at Un-P1-C4	
1xxx1D03	1. Clock card at Un-P1-C4 2. Clock card at Un-P1-C3	
1xxx1D10	1. The node controller at Un-Pm-C41 in the book specified by the location code reported with the SRC. 2. The other node controller at Un-Pm-C42 in the book specified by the location code reported with the SRC.	
1xxx1D11	1. The node controller at Un-Pm-C42 in the book specified by the location code reported with the SRC. 2. The other node controller at Un-Pm-C41 in the book specified by the location code reported with the SRC.	
1xxx1D12	The I/O hub card at Un-Pm-C65 in the book specified by the location code reported with the error.	Part locations and location codes
1xxx1D13	The I/O hub card at Un-Pm-C66 in the book specified by the location code reported with the error.	Part locations and location codes
1xxx1D14	The I/O hub card at Un-Pm-C39 in the book specified by the location code reported with the error.	
1xxx1D15	The I/O hub card at Un-Pm-C40 in the book specified by the location code reported with the error.	
1xxx5000	The system controller at Un-P1-C2	
1xxx5001	The system controller at Un-P1-C5	
1xxx8400	Replace the primary system controller. To determine which SC is the primary, see "Determine which SC is the primary system controller".	
1xxx8409	Replace the primary system controller. To determine which SC is the primary, see "Determine which SC is the primary system controller".	
1xxx8410 through 1xxx8417	Replace the primary system controller. To determine which SC is the primary, see "Determine which SC is the primary system controller".	
1xxx8420 through 1xxx8427	Replace the primary system controller. To determine which SC is the primary, see "Determine which SC is the primary system controller".	
1xxx8470 through 1xxx8477	Replace the primary system controller. To determine which SC is the primary, see "Determine which SC is the primary system controller".	

1xxx8710 through 1xxx871F	Replace the primary system controller. To determine which SC is the primary, see "Determine which SC is the primary system controller".	
1xxx8720, 1xxx8721	Replace the primary system controller. To determine which SC is the primary, see "Determine which SC is the primary system controller".	
1xxx8724, 1xxx8725	Replace the primary system controller. To determine which SC is the primary, see "Determine which SC is the primary system controller".	
1xxx8735	Replace the primary system controller. To determine which SC is the primary, see "Determine which SC is the primary system controller".	

This ends the procedure.

2. The failing system is a 9125-F2A node. Use the table below the find the appropriate action for the SRC you are working with.

Table 2. 9125-F2A

SRC	Replace this FRU	Link to locations information
1xxx1D12	The I/O hub card at Un-Pm-C37 in the book specified by the location code reported with the error.	Part locations and location codes
1xxx1D13	The I/O hub card at Un-Pm-C38 in the book specified by the location code reported with the error.	
1xxx8400	The I/O planar, Un-P1 in the node specified by the location code reported with the error.	
1xxx8409	The I/O planar, Un-P1 in the node specified by the location code reported with the error.	
1xxx8410	The I/O planar, Un-P1 in the node specified by the location code reported with the error.	
1xxx8420	The I/O planar, Un-P1 in the node specified by the location code reported with the error.	
1xxx8470	The I/O planar, Un-P1 in the node specified by the location code reported with the error.	
1xxx8710	The I/O planar, Un-P1 in the node specified by the location code reported with the error.	
1xxx8720, 1xxx8721	The I/O planar, Un-P1 in the node specified by the location code reported with the error.	

1xxx8724, 1xxx8725	The I/O planar, Un-P1 in the node specified by the location code reported with the error.	
1xxx8735	The I/O planar, Un-P1 in the node specified by the location code reported with the error.	

This ends the procedure.

CARDTMP

The cryptographic adapter has detected a voltage and/or temperature change in its physical operating environment.

Correct the voltage and/or temperature condition. Vary off the cryptographic device description associated with the device resource on the adapter resource and vary it back on.

CBLALL

An SPCN cable might be the failing item.

When there is a location and part number displayed on the control panel of a system or expansion tower, replace that FRU first.

Perform the following to determine the part number of the failing part.

1. Is the reference code 1xxx1502, 1xxx1512, 1xxx1522, or 1xxx1532?
 - **No:** Continue with the next step.
 - **Yes:** Exchange the items in the following table one at a time:

CCIN or FFC	Type and model	Part number	Description	Location code
28BB	5790, 7311-D11	23R0181	I/O backplane	Un-P1
	5790, 7311-D11	22R3958	Power supply	Un-Ex
	0595, 5095, 7311-D20	39J0515	I/O backplane	Un-P1
	0595, 5095, 7311-D20	39J2781	Power supply	Un-Ex
520C	5796, 7314-G30	See Finding parts, locations, and addresses.	I/O backplane	Un-P1
	5796, 7314-G30	42R4491	Power supply	Un-Ex

For all other units,

- SPCN cables
- Power distribution card

This ends the procedure.

2. Is the reference code 1xxx2612, 1xxx9012, 1xxx9013, 1xxx90F0, 1xxx9135, or 1xxxC62E?
 - **No:** Continue with the next step.
 - **Yes:** The failing item is the SPCN frame-to-frame cable or adapter. The following list shows the possible failing items, and the cable or adapter lengths when appropriate.
Use the following table to determine the part number for the field replaceable unit (FRU):

CCIN or FFC	Type and model	Part number	Description	Location code
-------------	----------------	-------------	-------------	---------------

1463		09P1251	SPCN cable (2 meters)	
1464		22R5219	SPCN cable (6 meters)	
1465		22R5221	SPCN cable (15 meters)	
1466		22R5222	SPCN cable 30.0 meters	
		21F9360	SPCN cable 60.0 meters	
0369		41U0128	SPCN optical cable (100.0 meters)	
1468		41U0129	Optical SPCN cable (250 meters)	
		39J3865	SPCN optical adapter	

This ends the procedure.

3. Is the reference code 1xxx2613?

- **No:** Continue with the next step.
- **Yes:** If there are two power supplies in the system, verify that both power supplies are plugged into the same line voltage (either 110V ac or 220V ac, or -48V dc if your system is configured to operate with this voltage). If this is not the case, correct it. See "Determine power cord, plug, and receptacle type" in the Planning topic, for the power cable part number for systems in your country or region.

This error code can also be posted if the power supply cannot support the hardware in the system. If there is only one power supply, and it's plugged into 110V ac, inform the customer that the power supply must be plugged into 220V ac. If the customer has two power supplies, the other option is to install the second power supply. **This ends the procedure.**

4. Is the reference code 1xxx6003?

- **No:** Continue with the next step.
- **Yes:** The failing item is the 12X cable attached to the I/O planar in the 5802 expansion unit. Replace the 12X cable going to the I/O planar at location Un-P1. If this does not resolve the problem, replace the I/O planar at location Un-P1.

Use the following table to determine the part number for the field replaceable unit (FRU):

CCIN or FFC	Type and model	Part number	Description	Location code
	5802	See Site and Hardware Planning Guide.	12X cable	
	5802	See Finding parts, locations, and addresses.	I/O planar	Un-P1

This ends the procedure.

5. Is the reference code 1xxx9133?

- **No:** Go to step 8.
- **Yes:** Continue with the next step.

6. Verify that the expansion units are cabled correctly with both RIO/HSL cables and power network connections and that they are powered on and not indicating an error condition. Resolve any problems you discover. Does the SRC persist?

- **No: This ends the procedure.**
 - **Yes:** Continue with the next step.
7. There might be a problem in the power network connection. Check the error log for another 1xxxxxxx SRC that was logged around the same time as the 1xxx9133 SRC. Is such an SRC present?
- **No:** Contact your next level of support. **This ends the procedure.**
 - **Yes:** Return to the "Starting a service call" procedure in the system unit's service guide and service the 1xxxxxxx SRC to resolve this problem. **This ends the procedure.**
8. Is the SRC 1xxx9137 or 1xxx9138?
- **No:** Return to the "Starting a service call" procedure in the system unit's service guide. **This ends the procedure.**
 - **Yes:** Continue with the next step.
- Note:** If you are performing maintenance on your system and as a result are now experiencing a 1xxx9137 or 1xxx9138 reference code, ensure your maintenance actions did not cause the reference codes before replacing any additional parts. Ignore the 1xxx9137 or 1xxx9138 reference codes if you are doing concurrent maintenance on the affected expansion unit, RIO/HSL loop, or 12X HCA loop associated with the affected expansion unit, cable, or adapter.
9. Visually verify the following:
- RIO/HSL or 12X HCA loop cables are connected and seated correctly.
 - If you are servicing a 9406-MMA or 9117-MMA, ensure the flex cables, if present, are connected and seated properly. Note that the flex cables are located on the front and back of the system.
 - All connected expansion units are powered on and not indicating an error condition.
- Note:** If a problem is found during any of these checks, resolve that problem. If your system is still producing an SRC, continue with the next step.
10. If your system produced SRC 1xxx9137, check the error log for SRC B700698x (RIO/HSL) or B70069Ex (12X HCA loop) that was logged around the same time as SRC 1xxx9137. Did your system produce SRC B700698x or B70069Ex?
- **No:** Go to the next step.
 - **Yes:** Return to the "Starting a service call" procedure in the system unit's service guide and resolve SRC B700698x or B70069Ex to solve the problem. **This ends the procedure.** **Note:** If your system produced SRC 1xxx9138, you have a faulty location code or vital product data. Contact your next level of support. **This ends the procedure.**
11. The SPCN firmware found more I/O resources than were found on the RIO/HSL loops and 12X HCA loops. This does not indicate an SPCN failure, even though the SRC was logged by the SPCN firmware; it indicates a problem in a RIO, HSL, or 12X HCA loop.
- A drawer's serial number should have been reported with the 1xxx9137 SRC. Locate this drawer, the RIO/HSL or 12X HCA cables going to it, and the bus adapter in the system unit drawer to which those cables are attached.
- Exchange the following parts, one a time, until the problem is resolved:
- a. The RIO/HSL or 12X HCA cables going to the drawer.
 - b. The RIO/HSL or 12X HCA adapter in the system drawer.
 - c. The RIO/HSL or 12X HCA adapter in the I/O drawer.
- Use the following table to determine the part number for the field replaceable unit (FRU):

CCIN or FFC	Type and model	Part number	Description	Location code
-------------	----------------	-------------	-------------	---------------

	8203-E4A, 8204-E8A, 9117-MMA, 9406-MMA, 9407-M15, 9408-M25, 9409-M50	See description	RIO, HSL, or 12X HCA loop cables. Refer to Site and hardware planning for cable FRU part numbers.	Un-P1-Cx-Ty
	9406-MMA, 9117-MMA	42R7352	I/O backplane	Un-P1
	8203-E4A, 9407-M15, 9408-M25	42R7898	System backplane	Un-P1
	8204-E8A, 9409-M50	10N9369	System backplane	Un-P1
	9406-MMA, 9117-MMA	39J0792	RIO/HSL-2 adapter	Un-P1-C8 or Un-P1-C9
	8203-E4A, 9407-M15, 9408-M25	10N9982	RIO/HSL-2 adapter	Un-P1-C6 or Un-P1-C8
	8204-E8A, 9409-M50	10N6859	RIO/HSL-2 adapter	Un-P1-C7 or Un-P1-C8
	9406-MMA, 9117-MMA	42R6849	Dual-port 12X Host Channel Attachment Adapter	Un-P1-C8 or Un-P1-C9
	8203-E4A, 9407-M15, 9408-M25	44V4645	Dual-port 12X Host Channel Attachment Adapter	Un-P1-C6 or Un-P1-C8
	8204-E8A, 9409-M50	10N9529	Dual-port 12X Host Channel Attachment Adapter	Un-P1-C7 or Un-P1-C8
	5790, 7311-D11	03N5633	RIO/HSL-2 adapter	Un-P1-C7
	0595, 5095, 7311-D20	39J0523	RIO/HSL-2 adapter	Un-P1-C05
	5796, 7314-G30	10N8782	Dual-port 12X HCA	Un-P1-C7

Is the problem resolved?

- **No:** Contact your next level of support. **This ends the procedure.**
- **Yes:** **This ends the procedure.**

CBLCONT

This symbolic FRU is used to show additional locations for the endpoints of cables.

This FRU appears in the serviceable event user interface of an operating system, service processor, or the HMC, and is associated with the cable FRU that precedes it in the list. The location code associated with this FRU is the location of another end of the same cable. Cable FRUs are shown in the display by listing the cable's part number or symbolic FRU first with the location code of one end of the cable. Each additional cable endpoint is represented as a "CBLCONT" FRU with a location code for another endpoint.

Note: If question marks (???) appear at the end of the location code, then the port could not be determined. Use the location code associated with the other end of the cable. If question marks appear for both port locations, use the isolation procedures suggested in the reference code table for this SRC.

CDAWKLD

Too many communications lines are in use.

CDTRAY

This symbolic FRU is not supported.

CHECK

Look here for information about the CHECK symbolic FRU.

If the attached device is an external device, do the following before exchanging any parts:

1. Ensure that the device is powered on.
2. Is there a SCSI interface between the IOP/IOA and the device?
 - **No:** Continue with the next step.
 - **Yes:** Perform the following:
 - If an interposer is required, make sure that it is connected between the I/O processor and the SCSI cable.
 - Ensure that the SCSI cable is seated correctly, and that there are no bent or damaged pins on the SCSI cable.
 - Ensure that a terminating plug is attached to the device end of the SCSI cable.
 - Continue with the next step.
3. Is there a Fibre Channel interface between the IOP/IOA and the device?
 - **No:** Continue with the next step.
 - **Yes:** Perform the following:
 - Verify that any hub or gateway devices are powered on.
 - Verify that the Fibre Channel cable is correctly connected to the ports.
 - If a cleaning kit is available, clean the Fibre Channel cable connectors.
 - Continue with the next step.
4. Perform the verification procedures which are located in the service guide for the system unit to see if the problem was corrected.

This ends the procedure.

CLCKMOD

The logic oscillator is failing.

For each unit, starting with the primary unit and then the secondary units, use the table below to determine which FRU to replace.

CCIN or FFC	Type and model	Part number	Description	Location code
	8203-E4A, 9407-M15, 9408-M25	42R7898	System backplane	U <i>n</i> -P1
	8204-E8A, 9409-M50	10N9369	System backplane	U <i>n</i> -P1
	9406-MMA, 9117-MMA	10N8752	Service processor card	U <i>n</i> -P1-C11
28DA	9406-MMA, 9117-MMA	42R7352	I/O backplane	U <i>n</i> -P1

CLNTSRC

The SRC in the error log is not recognized by the IBM i error analysis diagnostic component.

Unrecognized SRCs can occur when features or device types are installed that are newer than the level of diagnostic code in the version and release of the operating system or firmware that is running. Look up the SRC in the documentation for the version of the operating system or firmware you are running. If you do not find it, look in the documentation for a newer release of the operating system or firmware and follow the service actions listed there.

If you cannot find the SRC documented, contact your next level of support for assistance.

CLRNVRM

A problem might exist with the service processor NVRAM.

Perform the following:

1. Is your system managed by the Hardware Management Console (HMC)?

- **No:** Continue with the next step.
- **Yes:** Continue with step 3.

2. Perform the following:

- a. Power off the system.
- b. Using ASMI, select **System Service Aids > Factory Configuration**.
- c. Select **Continue** to clear the configuration.

Note: Clearing the configuration causes the loss of all the configured system settings (such as the HMC access and ASMI passwords, time of day, network configuration, hardware deconfiguration policies, and so on) that you might have set by using the user interfaces. Also, partition-related information and platform error logs are lost, and the service processor is reset. Before continuing with this operation, make sure that you manually record all settings that you need to preserve.

Ensure that the connection to HMC1 or HMC2 that is not being used to access the ASMI is disconnected from the network. Follow the instructions in the system service publications to configure the network interfaces after the reset.

This ends the procedure.

3. Your system is managed by the HMC. Do not replace the battery! Instead, clear the NVRAM by removing the battery for five minutes and then reinstalling it.

Note: Clearing the configuration causes the loss of all the configured system settings (such as the HMC access and ASMI passwords, time of day, network configuration, hardware deconfiguration policies, and so on) that you might have set by using the user interfaces. Also, partition-related information and platform error logs are lost, and the service processor is reset. Before continuing with this operation, make sure that you manually record all settings that you need to preserve. Ensure that the connection to HMC1 or HMC2 that is not being used to access the ASMI is disconnected from the network. Follow the instructions in the system service publications to configure the network interfaces after the reset.

This ends the procedure.

CMPRES1

The compressed device and the compression IOA are not compatible.

CNVTCRD

The card that converts SATA to IDE might be failing. This procedure will help you determine the failing part.

Use the following table to determine the part number for the field replaceable unit (FRU):

This ends the procedure.

CCIN or FFC	Type and model	Part number	Description	Location code
293D	9406-MMA, 9117-MMA	10N8968	SATA-to-IDE Media Backplane	U n-P4
2D06	8203-E4A, 8204-E8A, 9407-M15, 9408-M25, 9409-M50	10N9512	SATA-to-IDE converter card	U n-P2- C1

CRYPBAT

The batteries for the cryptographic adapter need to be replaced.

Attention: If you remove any of the batteries without first backing up the power with a fresh battery, the data in the card's protected memory could be lost, which would render the cryptographic adapter useless and require its replacement. Because the 4758-023 adapter contains 4 batteries, and the battery replacement kit contains only 2 batteries, *do not* attempt to remove or replace batteries unless you have two battery replacement kits. All other cryptographic adapters contain only 2 batteries, and therefore require only one battery replacement kit.

1. Use the following table to determine the battery kit (FRU) required:

CCIN or FFC	Type and model	Part number	Description	Location code
4758-001	9406-MMA, 9117-MMA	09J8199	PCI cryptographic coprocessor battery kit	U n-P1-C x
4758-023	9406-MMA, 9117-MMA	09J8199	PCI cryptographic coprocessor battery kit	U n-P1-C x
4764-001	9406-MMA, 9117-MMA	41V1061	PCI cryptographic coprocessor battery kit	U n-P1-C x

This ends the procedure.

CRYPTLP

Cryptographic adapter licensed internal code problem.

The licensed internal code for the cryptographic adapter does not ship with the system.

For systems with Licensed Internal Code V5R4M5 or earlier it is contained within the licensed program 5733-CY1 Cryptographic Device Manager. For systems with Licensed Internal Code V6R1M0 or later it is contained within the licensed program 5733-CY2 Cryptographic Device Manager.

Do one of the following:

- **If the SRC is B0136615**, ensure that this licensed program is loaded on the system. If it is not, vary off the cryptographic adapter, apply the licensed program to the system, and then vary on the cryptographic adapter. The vary-on process might take up to 15 minutes.
- **If the SRC is B0136619**, vary off the cryptographic adapter, apply the most recent version of the licensed program to the system, and then vary on the cryptographic adapter. The vary-on process might take up to 15 minutes.

This ends the procedure.

CTLPNCD

This symbolic FRU is not supported on the system. Continue with the next FRU in the failing item list.

CTLPNL

A control panel or display panel might be failing.

Use the following table to determine the part number for the field replaceable unit (FRU):

CCIN or FFC	Type and model	Part number	Description	Location code
	8203-E4A, 9407-M15, 9408-M25	10N9737	Control panel	U n-P2-D1
	8204-E8A, 9409-M50	42R5505	Control panel	U n-P2-D1
28D4	9406-MMA, 9117-MMA	39J3272	Control panel	U n-D1
	0595, 5095, 7311-D20	39J3087	Control panel	U n-L1
247B	5094	39J4611	I/O control panel	U n-NB1

CTPLPDU

The MAXFRAME value in CRTLINETH command is too large.

The configuration parameter that was identified as a possible problem can be verified by displaying the local area network line description with the DSPLIND command.

Vary off the line. Use the CHGLINETH command to reduce the MAXFRAME value. Then vary the line back on.

CTPNADR

The ADPTADR value in CRTLINETH command is specified incorrectly.

The configuration parameter that was identified as a possible problem can be verified by displaying the local area network line description with the DSPLIND command.

Vary off the line. Use the CHGLINETH command to change the ADPTADR value to *ADPT. Then vary the line back on.

DCA

A DCA needs to be replaced.

Use the following table to determine which DCA to replace, and then follow the link to locations information to find the appropriate removal information.

Table 1. Model 575 (9125-F2A)

SRC	FRU to replace	Link to locations information
1xxx8710	DCA at Un-E1	Part locations and location codes

Table 2. Model 590 and 595 (9199-FHA)

SRC	FRU to replace	Link to locations information
1xxx8710	DCA 1 in processor book Un-P2-E2	Part locations and location codes
1xxx8711	DCA 2 in processor book Un-P2-E1	
1xxx8712	DCA 1 in processor book Un-P6-E2	

SRC	FRU to replace	Link to locations information
1xxx8713	DCA 2 in processor book Un-P6-E1	
1xxx8714	DCA 1 in processor book Un-P3-E2	
1xxx8715	DCA 2 in processor book Un-P3-E1	
1xxx8716	DCA 1 in processor book Un-P7-E2	
1xxx8717	DCA 2 in processor book Un-P7-E1	
1xxx8718	DCA 1 in processor book Un-P4-E2	
1xxx8719	DCA 2 in processor book Un-P4-E1	
1xxx871A	DCA 1 in processor book Un-P8-E2	
1xxx871B	DCA 2 in processor book Un-P8-E1	
1xxx871C	DCA 1 in processor book Un-P5-E2	
1xxx871D	DCA 2 in processor book Un-P5-E1	
1xxx871E	DCA 1 in processor book Un-P9-E2	
1xxx871F	DCA 2 in processor book Un-P9-E1	

If the problem persists, check cable routing and connections.

DEVBPLN

A device backplane might be failing.

Perform the following:

- Does the SRC that sent you here begin with 506x, or are you working with an attached 5786 or 5787 disk expansion unit?
 - No:** Continue with the next step.
 - Yes:** Replace the SCSI interface card of the 5786, 5787 Disk Expansion Unit. See the following table for location and part number information. If this does not fix the problem, continue replacing the other failing items in the failing item list. If the other failing items do not fix the problem, replace the disk expansion unit chassis.
- Does the SRC that sent you here begin with a 509A or are you working with an attached 5886 disk expansion unit?
 - No:** Continue with the next step.
 - Yes:** Replace the mid-plane of the 5886 Disk Expansion Unit. See the following table for location and part number information.
- Does the SRC that sent you here begin with a 509D or are you working with an attached 5720 or 7214-1U2 expansion unit?
 - No:** Continue with the next step.
 - Yes:** This failing item is not applicable. Continue with the next item in the failing item list.
- Replace the device backplane, See the following table for location and part number information.

CCIN or FFC	Type and model	Part number	Description	Location code
	5786, 5787		Device backplane	Un-P2
	5886	42R7898	5886 SAS expansion unit midplane	Un-P1

293D	9406-MMA, 9117-MMA	10N8968	Removable media enclosure assembly (includes the media backplane)	Un-P4
------	-----------------------	---------	---	-------

5.

Use the following table to determine the part number for the field replaceable unit (FRU):

CCIN or FFC	Type and model	Part number	Description	Location code
506D	5786, 5787	12R9040	SCSI interface card 1 (top left), SCSI repeater card assembly, dual	Un-C2
506E	5786, 5787	12R9042	SCSI interface card 1 (top left, SCSI repeater card assembly, single)	Un-C2
506D	5786, 5787	12R9040	SCSI interface card 2 (top right), SCSI repeater card assembly, dual	Un-C3
506E	5786, 5787	12R9042	SCSI interface card 2 (top right), SCSI repeater card assembly, single	Un-C3
506D	5786, 5787	12R9040	SCSI interface card 3 (bottom left), SCSI repeater card assembly, dual	Un-C4
506E	5786, 5787	12R9042	SCSI interface card 3 (bottom left), SCSI repeater card assembly, single	Un-C4
506D	5786, 5787	12R9040	SCSI interface card 4 (bottom left), SCSI repeater card assembly, dual	Un-C5
506E	5786, 5787	12R9042	SCSI interface card 4 (bottom left), SCSI repeater card assembly, single	Un-C5
509B	5886	42R7898	5886 SAS expansion unit midplane	Un-P1

DEVICE

The addressed storage device is the failing item.

Perform the following.

1. Is the device location information available in the Service Action Log (SAL)?
 - **No:** Continue with the next step.
 - **Yes:** Exchange the failing item.
2. Find the IOP address and the device address (see The system reference code format description.

3. To determine the location of the I/O processor card, see Part locations and location codes and find the diagram of the system unit or the expansion unit. Then, find:
 - The IOP card location identified by the direct select address.
 - The addressed storage device location identified by the device address.
4. Exchange the failing device. Use the device type to help determine the part number.

This ends the procedure.

DEVTERM

The device terminating plug might be failing.

Perform the following:

1. Find the IOA type:
 - a. Find the IOA location information in the Service Action Log if it is available. If the location is not available, find the address of the IOA. See The system reference code format description. Use the address to find the location. See Part locations and location codes.
 - b. Find the IOA card in the system and read the type number of the card at that location.
2. Use the information in the following list to determine the failing terminating plug:

Storage IOA type	Action
2749	For device types 3490, 3570, 3590, 3995, and 7208, see . For all other devices, use part number 85F7887.
5702	Use part number 19P0874.
All others	The terminator is integrated into the backplane and not a separate failing item.

3. Exchange the failing item. Note: If the terminating plug is located on a backplane, go to symbolic FRU BACKPLN. Follow the procedure until the terminating plug is accessible and then remove or exchange the plug.

This ends the procedure.

DIMM 0

Use this topic to view the locations of DIMM 0, DIMM 1, DIMM 2, and DIMM 3 on the 2890 and 2892 Integrated xSeries Server (IXS) cards.

In the following two figures, the first DIMM from the top of the IXS card (DIMM 0) is the failing item. To determine the part number, go to symbolic FRU MEMORY. **This ends the procedure.**

Figure 1. Locations of DIMM 0, DIMM 1, DIMM 2, and DIMM 3 on 2890 Integrated xSeries Server (IXS) card.

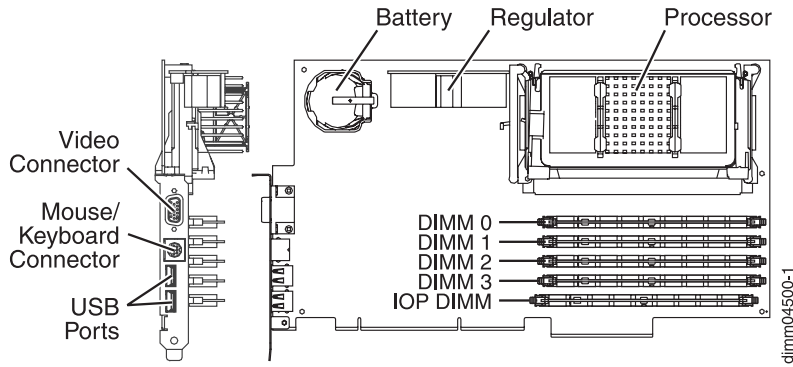

Figure 2. Locations of DIMM 0, DIMM 1, DIMM 2, and DIMM 3 on 2892 Integrated xSeries Server (IXS) card.

DIMM 1

Use this topic to view the locations of DIMM 0, DIMM 1, DIMM 2, and DIMM 3 on the 2890 and 2892 Integrated xSeries Server (IXS) cards.

In the following two figures, the second DIMM from the top of the IXS card (DIMM 1) is the failing item. To determine the part number, go to symbolic FRU MEMORY. **This ends the procedure.**

Figure 1. Locations of DIMM 0, DIMM 1, DIMM 2, and DIMM 3 on 2890 Integrated xSeries Server (IXS) card.

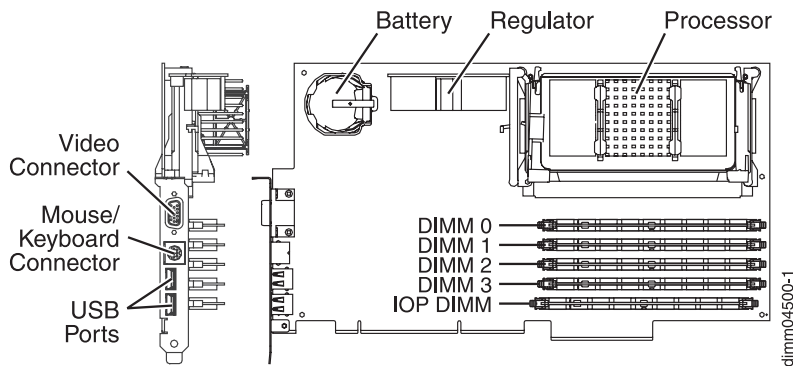

Figure 2. Locations of DIMM 0, DIMM 1, DIMM 2, and DIMM 3 on 2892 Integrated xSeries Server (IXS) card.

DIMM 2

Use this topic to view the locations of DIMM 0, DIMM 1, DIMM 2 and DIMM 3 on the 2890 and 2892 Integrated xSeries Server (IXS) card.

In the following two figures, the third DIMM from the top (DIMM 2) of the IXS card is the failing item. To determine the part number, go to symbolic FRU MEMORY. **This ends the procedure.**

Figure 1. Locations of DIMM 0, DIMM 1, DIMM 2, and DIMM 3 on 2890 Integrated xSeries Server (IXS) card.

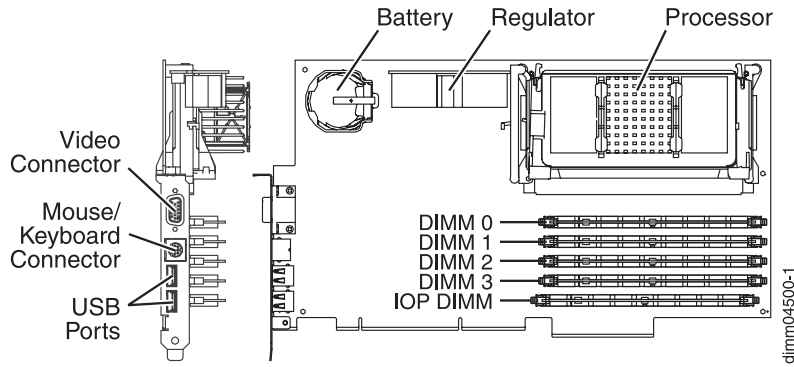

Figure 2. Locations of DIMM 0, DIMM 1, DIMM 2, and DIMM 3 on 2892 Integrated xSeries Server (IXS) card.

DIMM2_3

Use this topic to view the locations of DIMM 0, DIMM 1, DIMM 2 and DIMM 3 on 2892 Integrated xSeries Server (IXS) card.

The third or fourth DIMM from the top (DIMM 2 or DIMM 3) of the IXS card is the failing item. To determine the part number, go to symbolic FRU MEMORY. **This ends the procedure.**

Figure 1. Locations of DIMM 0, DIMM 1, DIMM 2 and DIMM 3 on 2892 Integrated xSeries Server (IXS) card.

DIMM 3

Use this topic to view the locations of DIMM 0, DIMM 1, DIMM 2 and DIMM 3 on the 2890 and 2892 Integrated xSeries Server (IXS) cards.

In the following two figures, the **fourth** DIMM from the top (DIMM 3) of the IXS card is the failing item. To determine the part number, go to symbolic FRU MEMORY.

Figure 1. Locations of DIMM 0, DIMM 1, DIMM 2 and DIMM 3 on 2890 Integrated xSeries Server (IXS) card

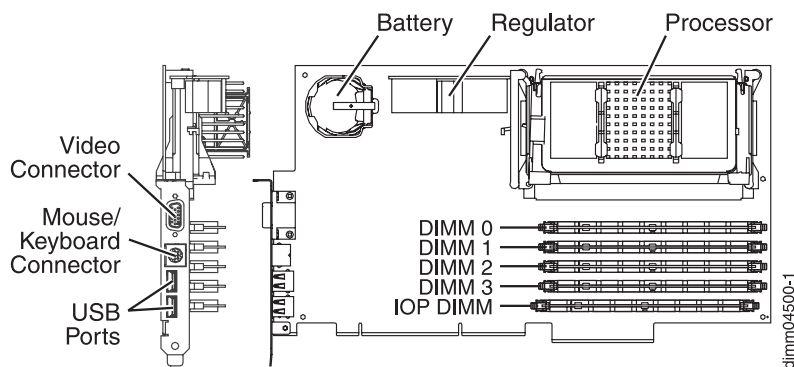

Figure 2. Locations of DIMM 0, DIMM 1, DIMM 2 and DIMM 3 on 2892 Integrated xSeries Server (IXS) card

DIMMO_1

Use this topic to view the locations of DIMM 0, DIMM 1, DIMM 2, and DIMM 3 on 2892 Integrated xSeries Server (IXS) card.

The first or second DIMM from the top (DIMM 0 or DIMM 1) of the IXS card is the failing item. To determine the part number, go to symbolic FRU MEMORY. **This ends the procedure.**

Figure 1. Locations of DIMM 0, DIMM 1, DIMM 2, and DIMM 3 on 2892 Integrated xSeries Server (IXS) card.

DISKDRV

The disk drive might be failing.

Do the following:

1. Is the device location information available in the Service Action Log?
 - **No:** Continue with the next step.
 - **Yes:** Exchange the failing item, to exchange the failing item, see the "Disk unit recovery procedure" in the service guide for the system unit. **This ends the procedure.**
 2. Find the direct select address and the device address. See The system reference code format description.
 3. See Part locations and location codes and find the diagram of the system unit or expansion unit. Use the direct select address and the device address to find the location of the disk unit.
 4. Is the SRC reported on the control panel?
 - **No:** Continue with the next step.
 - **Yes:** See The system reference code format description. The two rightmost characters of word 2 define the SRC format. Use the correct SRC format to locate the function that contains the characters *tttt lmmm*, where:
 - *tttt* = Type number
 - *l* = Level
 - *mmm* = Model
- Then go to step 6.
5. Remove the disk unit to determine the part number. Replace the disk unit. **This ends the procedure.**
 6. Use the drive type to determine the part to replace. If you do not know the type, remove the disk unit to determine the part number. Replace the disk unit. **This ends the procedure.**

DISKFAN

A fan in a 5720, 5786, 5787, 5886, 7031-D24, 7031-T24, or 7214-1U2 expansion unit might be failing.

Do one of the following:

- If the SRC that sent you here is 506x7611 or 506x7614, replace the 5786, 5787, 7031-D24, or 7031-T24 fan located in **Un-A1**. See the table below to find the part number and location of the item to replace. **This ends the procedure.**
- If the SRC that sent you here is 506x7621 or 506x7624, replace the 5786, 5787, 7031-D24, or 7031-T24 fan located in **Un-A2**. See the table below to find the part number and location of the item to replace. **This ends the procedure.**
- If the SRC that sent you here is 506x7631 or 506x7634, replace the 5786, 5787, 7031-D24, or 7031-T24 fan located in **Un-A3**. See the table below to find the part number and location of the item to replace. **This ends the procedure.**

- If the SRC that sent you here is 506x15xx , replace the 5786, 5787, 7031-D24, or 7031-T24 fans located in Un-A1, Un-A2, and Un-A3 one at a time until the problem is resolved. See the table below to find the part number and location of the item to replace. **This ends the procedure.**
- If the SRC that sent you here is 509A7614 or 509A7624, replace the 5886 power supply (internal fan) located in Un-E1. See the table below to find the part number and location of the item to replace. If this does not fix the problem, replace the power supply located in Un-E2 . **This ends the procedure.**
- If the SRC that sent you here is 509A7634 or 509A7644, replace the 5886 power supply (internal fan) located in Un-E2. See the table below to find the part number and location of the item to replace. If this does not fix the problem, replace the power supply located in Un-E1. **This ends the procedure**
- If the SRC that sent you here is 509D7614, replace the 5720 or 7214-1U2 fan located in Un-A1. See the table below to find the part number and location of the item to replace. **This ends the procedure**

Use the following table to determine the part number for the field replaceable unit (FRU):

CCIN or FFC	Type and model	Part number	Description	Location code
	5720 or 7214-1U2	95P4066	Fan	Un-A1
	5786, 5787, 7031-D24, or 7031-T24	12R9950<	Fan 1	Un-A1
	5786, 5787, 7031-D24, or 7031-T24	12R9950	Fan 2	Un-A2
	5786, 5787, 7031-D24, or 7031-T24	12R9950	Fan 3	Un-A3
	5886	39R6547	power supply (internal fan)	Un-E1
	5886	39R6547	power supply (internal fan)	Un-E2

DISKIMG

There may be a problem with the Network Server Description (NWSD).

First, vary off and then vary back on the NWSD. If this does not correct the problem, delete and re-create the NWSD, or call your next level of support.

DISKPWR

A power supply in a 5720, 5786, 5787, 5886, 7031-D24, 7031-T24, or 7214-1U2 expansion unit might be failing.

Do one of the following:

- If the system reference code (SRC) that sent you here is 506x1511 or 506x1515, replace the 5786, 5787, 7031-D24, or 7031-T24 expansion unit power supply located in Un-E1. See the following table for the part number and location of the item to replace. If this does not fix the problem, replace the power supply located in Un-E2. **This ends the procedure.**
- If the SRC that sent you here is 506x1521 or 506x1525, replace the 5786, 5787, 7031-D24, or 7031-T24 expansion unit power supply located in Un-E2. See the following table for the part number and location of the item to replace. If this does not fix the problem, replace the power supply located in Un-E1. **This ends the procedure.**
- If the SRC that sent you here is 509A1511 or 509A1515, replace the 5886 power supply located in Un-E2. See the following table for the part number and location of the item to replace. If this does not fix the problem, replace the power supply located in Un-E1. **This ends the procedure.**

- If the SRC that sent you here is 509A1521 or 509A1525, replace the 5886 power supply located in Un-E2. See the following table for the part number and location of the item to replace. If this does not fix the problem, replace the power supply located in Un-E1. **This ends the procedure.**
- If the SRC that sent you here is 509D1511 or 509D1515, replace the 5720 or 7214-1U2 power supply located in Un-E1. See the following table for the part number and location of the item to replace. If this does not fix the problem, replace the power supply located in Un-E2. **This ends the procedure.**

Use the following table to determine the part number for the field replaceable unit (FRU):

CCIN or FFC	Type and model	Part number	Description	Location code
	5786, 5787, 7031-D24, 7031-T24	12R9078 (966 Watt) 15R7998 (845 Watt) Note: Use with a power supply having the same wattage.	Power supply 1 (left)	Un-E1
	5786, 5787, 7031-D24, 7031-T24	12R9078 (966 Watt) 15R7998 (845 Watt) Note: Use with a power supply having the same wattage.	Power supply 2 (right)	Un-E2
	5886	39R6547	Power supply 1 (left)	Un-E1
	5886	39R6547	Power supply 2 (Right)	Un-E2
	5720, 7214-1U2	95P3651	Power supply	Un-Ex

DSKUNIT

DSKUNIT is similar to the symbolic FRU DISKDRV.

See symbolic FRU DISKDRV.

DPAC

The two-port adapter cable is the failing item.

Use the following table to determine the part number for the field replaceable unit (FRU):

CCIN or FFC	Type and model	Part number	Description	Location code
	8204-E4A, 8204-E8A, 9117-MMA, 9406-MMA, 9407-M15, 9408-M25, 9409-M50	21F9345	Two-port adapter cable	Un -P1-Cx -Ty

DRVSWCH

The address switches on an optical disk drive in the optical library need to be checked and verified.

Refer to the "All 3995 Publications and Documentation" Web site at <http://snjInt02.sanjose.ibm.com/tape/tapetec.nsf/pages/3995pub> for more information.

DISKTRY

This symbolic FRU is no longer supported.

EACODE

An error occurred in the error analysis Licensed Internal Code.

Contact your next level of support for assistance.

EXTREMD

An external removable media storage device might be failing.

1. Perform symbolic FRU CHECK before removing or replacing parts. Return here if no problems are identified.
2. Use the device type and refer to the appropriate service documentation for that device. This documentation will help you determine the part numbers and replacement procedures to use during this repair action.
3. If you are unable to locate the documentation for the specific device, contact your next level of support for assistance.

This ends the procedure.

EXTSCSI

The external signal cable may be failing.

Perform the following:

1. Is more than one device attached?
 - **No:** Continue with the next step.
 - **Yes:** See the device documentation for information about setting the device address. **This ends the procedure.**
2. Is the attached device in the system unit?
 - **No:** Continue with the next step.
 - **Yes:** Use symbolic FRU BACKPLN to determine which signal cables to replace. **This ends the procedure.**
3. Is the attached device a 358x device?
 - **No:** Continue with the next step.
 - **Yes:** For specific 358x attachment cable information, refer to the specific device and model service documentation, or contact your next level of support. **This ends the procedure.**
4. Find the IOA type:
 - a. Find the IOA location.
 - b. Use the location information of the IOA in the Service Action Log if it is available. If the location is not available, find the address. See The system reference code format description. Use the address to find the location. See Part locations and location codes.
 - c. Find the IOA card in the system and read the type number of the card at that location.
5. Find the IOA type, the attached device, the cable length, and the cable part number in the following list.
6. Verify that the part number in the list is the same as the part number on the cable.
7. For external devices that are not found in the following list, use the device type and refer to the appropriate service documentation for that device. The service documentation for that device will help you determine the FRU part numbers and replacement procedures you are to use during this repair action. If you are unable to locate the documentation for your specific device, then contact your next level of support for assistance.

Table 2. Table 1. External device and part numbers

IOP or IOA Type	Device	Lengths	Part Number
2749	3490, 3490/Exx, 3590	2.8 meters	05H4647
2749	3490, 3490/Exx, 3590	4.5 meters	05H4648
2749	3490, 3490/Exx, 3590	12.0 meters	05H4649
2749	3490, 3490/Exx, 3590	18.0 meters	05H4650
2749	3490, 3490/Exx, 3590	25.0 meters	05H4651
2749	3490/Fxx, 3570, 9427, 7208/342	0.5 meters	49G6456 Note: For 9427 see the note following this table.
2749	3490/Fxx, 3570, 9427, 7208/342	4.5 meters	49G6457 Note: For 9427 see the note below this table.
2749	3490/Fxx, 3570, 9427, 7208/342	12.0 meters	49G6458 Note: For 9427 see the note below this table.
2749	3490/Fxx, 3570, 9427, 7208/342	18.0 meters	49G6459 Note: For 9427 see the note below this table.
2749	63A0		See device documentation to determine cable part numbers
2749	7208/012, 7208/222	1.5 meters	52G0174
2749	7208/012, 7208/222	4.0 meters	59H3462
2749	7208/012, 7208/222	12.0 meters	59H3463
2749	7208/232, 7208/234, 9348	0.5 meters	06H6037
2749	7208/232, 7208/234, 9348	4.0 meters	59H3460
2749	7208/232, 7208/234, 9348	12.0 meters	05H5543
2749	3995	12.0 meters	05H5543
2782, 5702, 5703, 571A	7206/VX2, 7207/122, 7208/345, 7210/020, 7210/025	1.5 meters	19P4508, or 19P4506 with 19P0482 interposer cable. For other device types, see the device documentation to determine cable part numbers.
2782, 5702, 5703, 571A	7206/VX2, 7207/122, 7208/345, 7210/020, 7210/025	2.5 meters	19P0279, or 35L1307 with 19P0482 interposer cable. For other device types, see the device documentation to determine cable part numbers.

Table 2. Table 1. External device and part numbers (continued)

IOP or IOA Type	Device	Lengths	Part Number
2782, 5702, 5703, 571A	7206/VX2, 7208/345	4.5 meters	19P0050 For other device types, see the device documentation to determine cable part numbers.
2782, 5702, 5703, 571A	7206/VX2, 7208/345	10 meters	19P0048 For other device types, see the device documentation to determine cable part numbers.
571B, 571F	5786 or 5787 expansion unit	1 meter	36R2585
571B, 571F	5786 or 5787 expansion unit	3 meters	36R2576
571B, 571F	5786 or 5787 expansion unit	5 meters	36R2577
571B, 571F	5786 or 5787 expansion unit	10 meters	36R2578
571B, 571F	5786 or 5787 expansion unit	20 meters	36R2579

Notes:

- All cables for the 9427 tape library must include an interposer (part 05H3834) on the device end of the cable.
- All cables for the 3996 and 399F attachment are the responsibility of the external device service.
- For specific 358X attachment cable information, refer to the specific device and model service documentation, or contact your next level of support.

This ends the procedure.

FCCABLE

The fibre channel cable may be failing.

Use the part number on the cable to determine the part number to replace.

FCCODE

An error has been detected in the fibre channel gateway device licensed internal code.

See the gateway device service documentation for possible corrective actions.

FCDEV

The attached fibre channel device or fiber channel gateway device is the failing item.

Is there a fibre channel gateway device between the fiber channel I/O adapter and the device?

- **No:** See the attached device service documentation to determine the parts to replace. **This ends the procedure.**
- **Yes:** See symbolic FRU FCGATE. **This ends the procedure.**

FCGATE

The fibre channel gateway device is the failing item.

Use the gateway device service documentation to determine the parts to replace.

FCINTF

An error has been detected on the fibre channel interface.

The failure may be any component between and including the fibre channel IOA and the storage device. To continue diagnosis, use existing fibre channel service procedures or contact your next level of support.

FCIOA

The fibre channel I/O adapter is the failing item.

Replace the fibre channel I/O adapter using the I/O adapter location information in the Service Action Log if it is available. If the location is not available, find the address of the I/O adapter, see The system reference code format description. Use the address to find the location. See Part locations and location codes. If an I/O Processor SRC sent you here, replace the fibre channel I/O adapter associated with the I/O processor that logged the SRC.

Use the following table to determine the part number for the field replaceable unit (FRU):

CCIN or FFC	Type and model	Part number	Description	Location code
2787	9406-MMA	80P6417	Fibre Channel IOA (for disk drive attachment only)	U n-P1-C x
280D	9406-MMA	03N5014	4 Gbps Fibre Channel (1 Port) adapter	U n-P1-C x
280E	9406-MMA	03N5016	PCI-X Fibre Channel disk controller	U n-P1-C x
5704	9406-MMA	80P6416	Fibre Channel IOA (for removable media attachment only)	U n-P1-C x
576B	9406-MMA	32N1294	4 Gbps Fibre Channel (2 Port) adapter	U n-P1-C x
5774	9406-MMA	10N7255	Gigabit PCI Express Dual Port Fibre Channel Adapter	U n-P1-C x
57FC	9406-MMA	To determine the FRU part number, remove the adapter from the system.	Fibre Channel IOA	U n-P1-C x

FCPORT

The fibre channel IOA port might be the failing item.

Perform the following:

1. If the system has logical partitions, perform this procedure from the logical partition that reported the problem. To determine if the system has logical partitions, go to Determining if the system has logical partitions before continuing with this procedure.
2. Access SST/DST by doing one of the following:
 - a. If you can enter a command at the console, access system service tools (SST). See "System Service Tools (SST)" in the service guide for the server.
 - b. If you cannot enter a command at the console, perform an IPL to DST. See Performing an IPL to dedicated service tools.
 - c. If you cannot perform a type A or B IPL, perform a type D IPL from removable media.

3. Is a Fibre Channel IOA URC (last four digits of SRC) 3120 or 3121 logged or been logged within 5 minutes of the SRC that sent you to this symbolic FRU?
 - **Yes:** Continue with the next step.
 - **No:** The Fibre Channel IOA port has not failed. See the next FRU in the FRU list. **This ends the procedure.**
4. Did you perform a D IPL to get to DST?
 - **Yes:** Continue with the next step.
 - **No:** Continue with step 6.
This ends the procedure.
5. Use the Product Activity Log to get the resource name for the 3120 or 3121 SRC. See Using the product activity log. Using the resource name, perform the following steps in DST/SST:
 - a. Click **Start a service tool Hardware service manager System bus resources**.
 - b. If the resource is an I/O processor, use "Resources associated with IOP" to find and display detail for the Fibre Channel I/O adapter. If the resource is a Fibre Channel I/O adapter, use "Resources associated with the IOP for all type 2847 I/O processors" to find and display the Fibre Channel I/O adapter.
 - c. Select the **Display additional port information** function key on the Auxiliary Storage Hardware Resource Detail display.
Does the Port status field indicate that the port is active?
Note: If 3120 is logged, check to see if port 0 is active. If 3121 is logged, check to see if port 1 is active.
 - **Yes:** Continue with step 7.
 - **No:** Continue with step 9.
6. Use the Service Action Log to get the resource name for the 3120 SRC. See Searching the service action log. Using the resource name, perform the following steps in DST/SST:
 - a. Click **Start a service tool > Hardware service manager > Locate resource by resource name**.
 - b. Enter the resource name.
 - c. Click the **Display detail** option for the Fibre Channel I/O adapter on the Logical Hardware Resources display.
 - d. Click the **Display additional port information** function key on the Auxiliary Storage Hardware Resource Detail display.
Does the Port status field indicate that the port is "active"? **Note:** If 3120 is logged, check to see if port 0 is active. If 3121 is logged, check to see if port 1 is active.
 - **Yes:** Continue with the next step.
 - **No:** Go to step 9.
7. The port is now active. Has a 1750/2105/2107 3002 SRC occurred around the time the problem was first reported?
 - **Yes:** Continue with the next step.
 - **No:** No further service actions are required. **This ends the procedure.**
8. A 1750/2105/2107 3002 has occurred, and the link has gone from not active to active. The Fibre Channel IOA port is functional. Choose from the following options:
 - If the disk units that reported the 1750/2105/2107 3002 SRC are usable, then no further service actions are required. **This ends the procedure.**
 - If the disk units that reported the 1750/2105/2107 3002 SRC are not usable, then go back to the 1750/2105/2107 3002 FRU list and work with a FRU other than FCPORT. **This ends the procedure.**
9. Clean the Fibre Channel IOA wrap plug using the cleaning kit. Follow the instructions in the *Fiber Optic Cleaning Procedures*, order number SY27-2604. If the wrap plug has been lost, order and clean a new one.

10. Perform the following steps:
 - a. Install the wrap plug on the Fibre Channel IOA.
 - b. After the wrap plug has been installed, wait 5 seconds.
 - c. Choose from the following options:
 - If you are on the Additional Port Information display, use the **Refresh** function key.
 - If you are not already on the Additional Port Information display, use the instructions from step 6

Is the port status now "active"?

 - **Yes:** Continue with the next step.
 - **No:** Replace the Fibre Channel IOA. See symbolic FRU FCIOA for further instructions and the FRU part number. **This ends the procedure.**
11. Ask the customer whether the Fibre Channel IOA will attach devices now or whether the Fibre Channel IOA is to be used at a later time.

Is the Fibre Channel IOA intended to attach devices at this time?

- **No:** The wrap plug remain installed on the Fibre Channel IOA when it is not in use. No further service actions are required. **This ends the procedure.**
- **Yes:** Perform the following steps:
 1. Unplug the wrap plug from the Fibre Channel IOA and wait until the port status becomes "Not active" using the Refresh function key on the Additional Port Information display. The failure has been isolated to the first link, which includes any of the cables or junctions between the Fibre Channel IOA port and the first Fibre Channel hub, switch, gateway, or device.
 2. Use existing Fibre Channel service procedures to continue diagnosis of this first link until the port status becomes active, or contact your next level of support. **This ends the procedure.**

FRPORT

The RIO/HSL/12X controller or adapter on one end of the link might be the failing item.

If you were sent to this procedure as a result of a B700 6985 SRC, and this is the only FRU in the FRU list, then the system cannot sense any I/O units on a RIO/HSL/12X loop and there is at least one cable attached to a port on that loop. In this case, go to Reference codes and look up SRC B700 6985 and work from the full FRU list provided there.

Note: The other end of the link is given in the symbolic FRU TOPORT.

To find the failing RIO/HSL/12X adapter, do the following:

1. Record the bus number (BBBB) in word 7 of the reference code. See Analyzing a RIO/HSL/12X or PCI bus reference code.

Note: If the previous link does not function in your environment, search for the topic in the service guide for server on which you are working.

2. Use one of the following procedures to find the failing RIO/HSL/12X adapter:
 - Finding the failing RIO/HSL/12X adapter using IBM i operating system
 - Finding the failing RIO/HSL/12X adapter using AIX® or Linux®
 - Finding the failing RIO/HSL/12X adapter using the HMC

Finding the failing RIO/HSL/12X adapter using IBM i operating system

1. Sign on to SST or DST if you have not already done so.
2. Select **Start a service tool** → **Hardware service manager** → **Logical hardware resources** → **High-speed link (HSL) resources**.

3. Select **Include non-reporting resources** then click **Display detail** for the RIO/HSL/12X loop that you want to examine. The loop number is the number from word 7 of the reference code above.
4. The display that appears shows the port status of the Network Interface Controller (NIC) for the loop that you selected. Record the resource name, type-model, and serial number.
5. If the status of the "Leading port to next resource" is **operational**, then select **Follow Leading Port**. Repeat this action until the status changes to **failed**. Does the resource name ever match the one recorded in the previous step?
 - **Yes:** You have traveled around the loop and did not find a failed link. **This ends the procedure.**
 - **No:** Continue with the next step.
6. When the status is **failed**, you have found the **from** port.

Note: This screen will be the starting point for symbolic FRU TOPORT.

7. Record the following information of this resource:
 - a. Resource name, card type and model, and part number
 - b. Link status of each port (make sure to note if a port is designated as internal)
8. Select **Cancel** to return to the Work with High-speed link (HSL) resources display.
9. For the loop with the failure, select **Resources associated with loop**.
10. For the RIO/HSL/12X I/O bridge with the resource name that you recorded, select **Associated packaging resources**.
11. Select **Display detail** and record the location for the first failing resource.
12. Replace this FRU, use the following table to determine the failing FRU part number.

CCIN or FFC	Type and model	Part number	Description	Location code
2886	5094, 5096	39J0669	RIO/HSL optical bus adapter	Un-CB1-C10
2887	5094, 5096	39J0527	RIO/HSL2 adapter	Un-CB1-C10
28E7	5094, 5096	39J0523	RIO/HSL2 adapter	Un-CB1-C10
28FF	5790, 7311-D11	03N5633	RIO/HSL2 adapter	Un-P1-C7
28E7	0595, 5095, 7311-D20	39J0523	RIO/HSL2 adapter	Un-P1-C5
520A	5796, 7314-G30	10N8782	Dual-port 12X adapter	Un-P1-C7
	8203-E4A, 9407-M15, 9408-M25	10N9982	RIO-2/HSL-2 adapter	Un-P1-Cx
	8203-E4A, 9407-M15, 9408-M25	44V4645	GX DUAL-PORT 12X HCA	Un-P1-Cx
	8204-E8A, 9409-M50	10N9180	RIO-2/HSL-2 adapter	Un-P1-Cx
	8204-E8A, 9409-M50	10N9533	GX DUAL-PORT 12X HCA	Un-P1-Cx
1800	9406-MMA, 9117-MMA	39J0792	RIO/HSL-2 adapter	Un-P1-Cx
1802	9406-MMA, 9117-MMA	42R6849	GX DUAL-PORT 12X HCA	Un-P1-Cx

This ends the procedure.

Finding the failing RIO/HSL/12X adapter using AIX or Linux

1. Determine on which RIO/HSL/12X loop the failing adapter is located. Refer to Converting the loop number to RIO/HSL/12X port location labels.

Note: If the previous link does not function in your environment, search for the topic in the service guide for the server on which you are working.

2. Identify each unit in the loop by following the cable.
3. Power down the system and remove all expansion units in the loop that starts and ends at the ports given in the previous step.
4. Power on the system to partition standby and check for the same SRC that sent you here. Did the SRC reoccur?
 - **No:** Power down the system and add the next unit in the original loop. Repeat this step.
 - **Yes:** If there are no expansion unit in the loop, replace the controller on the system unit. Otherwise, the RIO/HSL/12X adapter in the last I/O unit added is possibly the failing item. Use the following table to determine the part number for the field replaceable unit (FRU):

CCIN or FFC	Type and model	Part number	Description	Location code
28FF	5790, 7311-D11	03N5633	RIO/HSL2 adapter	Un-P1-C7
28E7	0595, 5095, 7311-D20	39J0523	RIO/HSL2 adapter	Un-P1-C5
520A	5796, 7314-G30	10N8782	Dual-port 12X adapter	Un-P1-C7
	8203-E4A, 9407-M15, 9408-M25	10N9982	RIO-2/HSL-2 adapter	Un-P1-Cx
	8203-E4A, 9407-M15, 9408-M25	44V4645	GX DUAL-PORT 12X HCA	Un-P1-Cx
	8204-E8A, 9409-M50	10N9180	RIO-2/HSL-2 adapter	Un-P1-Cx
	8204-E8A, 9409-M50	10N9533	GX DUAL-PORT 12X HCA	Un-P1-Cx
1800	9406-MMA, 9117-MMA	39J0792	RIO/HSL-2 adapter	Un-P1-Cx
1802	9406-MMA, 9117-MMA	42R6849	GX Dual-Port 12X HCA	Un-P1-Cx

This ends the procedure.

Finding the failing RIO/HSL/12X adapter using the HMC

1. Determine on which RIO/HSL/12X loop the failing adapter is located. Refer to Converting the loop number to RIO/HSL/12X port location labels.

Note: Note: If the previous link does not function in your environment, search for the topic in the service guide for the server on which you are working.

2. Identify each unit in the loop by following the cable.
3. Power down the system and remove all expansion units in the loop that starts and ends at the ports given in the previous step.
4. Power on the system to partition standby and check for the same SRC that sent you here. Did the SRC reoccur?
 - **No:** Power down the system and add the next unit in the original loop. Repeat this step.
 - **Yes:** If there are no expansion unit in the loop, replace the controller on the system unit. Otherwise, the RIO/HSL/12X adapter in the last I/O unit added is possibly the failing item. Use the following table to determine the part number for the field replaceable unit (FRU):

Table 3. Part number and FRU listing

CCIN or FFC	Type and model	Part number	Description	Location code
28FF	5790, 7311-D11	03N5633	RIO/HSL2 adapter	Un-P1-C7

Table 3. Part number and FRU listing (continued)

CCIN or FFC	Type and model	Part number	Description	Location code
28E7	0595, 5095, 7311-D20	39J0523	RIO/HSL2 adapter	Un-P1-C5
520A	5796, 7314-G30	10N8782	Dual-port 12X adapter	Un-P1-C7
	8203-E4A, 9407-M15, 9408-M25	10N9982	RIO-2/HSL-2 adapter	Un-P1-Cx
	8203-E4A, 9407-M15, 9408-M25	44V4645	GX DUAL-PORT 12X HCA	Un-P1-Cx
	8204-E8A, 9409-M50	10N9180	RIO-2/HSL-2 adapter	Un-P1-Cx
	8204-E8A, 9409-M50	10N9533	GX DUAL-PORT 12X HCA	Un-P1-Cx
1800	9406-MMA, 9117-MMA	39J0792	RIO/HSL-2 adapter	Un-P1-Cx
1802	9406-MMA, 9117-MMA	42R6849	GX Dual-Port 12X HCA	Un-P1-Cx

This ends the procedure.

FWADIPL

Look here for information about FWADIPL symbolic FRU.

Perform the following:

1. Contact your network administrator to verify that the bootp server is correctly configured for this client.
2. Check the network connection. If the network connections are OK, retry the operation. If there is no network connection, contact the network administrator.
3. If there are no problems with the bootp server or the network connections, replace the adapter from which you are trying to boot. See Managing PCI adapters for the adapter FRU part number.

This ends the procedure.

FWCD1

Look here for information about FWCD1 symbolic FRU.

Perform the following procedure.

1. If the problem persists, the CD in the USB CDROM drive might not be readable. Remove the CD and insert another CD.
2. If the problem persists after replacing the CD, replace the USB CDROM drive.
3. Replace the USB adapter to which the drive is attached. Use the following table to determine the part number for the field replaceable unit (FRU):

CCIN or FFC	Type and model	Part number	Description	Location code
28EF	8203-E4A, 8204-MMA, 9407-M15, 9408-M25, 9406-MMA, 9117-MMA	80P2994	2 Port USB PCI adapter	Un-P1-Cx-Ty

This ends the procedure.

FWCD2

Look here for information about FWCD2 symbolic FRU.

Perform the following procedure.

1. Check for server firmware updates. Apply if available.
2. If the problem persists, replace the USB CD-ROM drive. Note the device type and refer to Managing devices to determine the FRU part number to replace.
3. Replace the USB adapter to which the drive is attached. Use the following table to determine the part number for the field replaceable unit (FRU):

CCIN or FFC	Type and model	Part number	Description	Location code
28EF	8203-E4A, 8204-E8A, 9117-MMA, 9406-MMA, 9407-M15, 9408-M25, 9409-M50	80P2994	2 Port USB PCI adapter	U n-P1-C x-T y

This ends the procedure.

FWCONS

The console display might be failing.

1. If your server has an attached console, but the console display is not working, refer to the documentation for the display or try substituting a known good display for the one that is failing.
2. If you can see selection screens on the terminals, press the appropriate key on the input device within 60 seconds. If the console does not respond to the keystroke:
 - a. If you are selecting the console with a keyboard attached to the system, replace the keyboard, see the service documentation for the system unit for keyboard part numbers. If the keyboard does not fix the problem, replace the service processor. Use the following table to determine the part number for the field replaceable unit (FRU):

CCIN or FFC	Type and model	Part number	Description	Location code
	8203-E4A, 9407-M15, 9408-M25	42R7898	System backplane (integrated service processor card)	U n-P1
	8204-MMA	10N9369	System backplane (integrated service processor card)	U n-P1
	9406-MMA, 9117-MMA	10N8752	Service processor card	U n-P1-C11

- b. If you are selecting the console with an ASCII terminal, suspect the terminal. Use the problem determination procedures for the terminal.

Note: The ASCII terminal settings should be:

- 19,200 baud
- No parity
- 8 data bits
- 1 stop bit

This ends the procedure.

FWENET

This symbolic can help determine a problem with an ethernet adapter.

Perform the following.

1. Verify that the MAC address is properly programmed in the adapter's EPROM.
2. Replace the adapter specified by the location code. See Managing PCI adapters for PCI adapter FRU part numbers.

This ends the procedure.

FWFLASH

Symbolic FRU FWFLASH indicates that you might need to reload the server's firmware.

Perform the following:

1. Reboot the server or partition.
2. Reflash the server firmware. See Updates.
3. Reboot the failing partition.

This ends the procedure.

FWFWPBL

There might be a platform firmware problem.

Look here for information about FWFWPBL symbolic FRU.

Perform the following:

1. Check for platform firmware updates. See Updates.
2. Contact service support.

This ends the procedure.

FWHANG

Symbolic FRU FWHANG is not supported at this time.

FWHOST

Symbolic FRU FWHOST can help in the event that your server appears hung while booting.

If the system is not connected to an active network or if the target server is inaccessible (this can also result from incorrect IP parameters being supplied), the system will still attempt to boot and, because timeout durations are necessarily long to accommodate retries, the system may appear to be hung.

Perform the following:

1. Restart the system and access the SMS utilities.
2. In the utilities menus, check the following:
 - Is the intended boot device correctly specified in the boot list?
 - Are the IP parameters correct?
 - Verify the network connection (the network could be down).
 - Have the network administrator verify the server configuration for this client.
 - Attempt to "ping" the target server using the SMS Ping utility.

This ends the procedure.

FWIDE1

The media or device might be failing.

If you receive symbolic FRU FWIDE1, perform the following:

1. Replace the media in the device specified by the location code.
2. Replace the device specified by the location code. See Managing devices for device FRU part numbers.

This ends the procedure.

FWIDE2

The cables, media or device might be failing.

If you received symbolic FRU FWIDE2, perform the following:

1. Verify that the signal and power cables are properly attached to the device specified by the location code. After they have been verified and repaired if necessary, retry the operation.
2. If the problem persists, the media in the device might not be readable. Remove the media and try another copy.
3. Replace the device specified by the location code. See Managing devices for device FRU part numbers.

This ends the procedure.

FWIPIPL

Network address problem.

If you receive symbolic FRU FWIPIPL, perform the following:

1. Contact your network administrator to verify that the network addresses on the server and gateway are correct.
2. Use the System Management Services menu to correct the network addresses on the server if necessary.

This ends the procedure.

FWLPAR

Look here for information about FWLPAR symbolic FRU.

If you receive symbolic FRU FWLPAR, perform one of the following:

- If a location code was reported with the error, probing failed for the PCI slot connector:
 1. Check for platform firmware updates. Apply the update if there is one available.
 2. Check for adapter firmware updates, apply if available. If there are no updates available, replace the adapter. See Managing PCI adapters for PCI adapter FRU part numbers. If this does not resolve the problem, replace the I/O backplane on which the slot connector is located. Use the following table to determine the part number for the field replaceable unit (FRU):

CCIN or FFC	Type and model	Part number	Description	Location code
	8203-E4A, 9407-M15, 9408-M25	42R7898	System backplane	Un-P1
	8204-E8A, 9409-M50	10N9369	System backplane	Un-P1

	9406-MMA, 9117-MMA	42R7352	I/O backplane	Un-P1
	5790, 7311-D11	80P6626	I/O backplane	Un-P1
	0595, 5095, 7311-D20	39J0515	I/O backplane	Un-P1
	5796, 7314-G30	See Finding parts, locations, and addresses.	I/O backplane	Un-P1

- If no location code was reported with the error, The connector was not found:
 1. Check for platform firmware updates, apply if available.
 2. If no updates are available, contact your next level of support.

This ends the procedure.

FWMBOOT

Look here for information about FWMBOOT symbolic FRU.

This checkpoint appears on the operator panel when partition firmware has entered the boot devices menu in the SMS because the multi-boot flag was turned on.

The firmware is waiting for input from the user. If the firmware console is not open, the user cannot see the boot devices menu. In this case, the user might mistakenly assume that the system is hung. System firmware only progresses past this point when the user provides the required input.

FWNIM

Look here for information about FWNIM symbolic FRU.

If this error occurs during the installation of AIX^(R) via a process called a NIM push, the *set_bootlist* attribute may not have been set correctly on the NIM master.

See the appropriate **AIX 5.x Installation Guide and Reference** for the level of AIX that is being installed for more information.

If this error occurs at any other time, perform the following:

1. Check for platform firmware updates. Apply if available.
2. Call service support.

This ends the procedure.

FWNVR1

Look here for information about FWNVR1 symbolic FRU.

An error reported against the NVRAM can be caused by low battery voltage and (more rarely) power outages that occur during normal system usage.

With the exception of the BA170000 error, these errors are warnings that the NVRAM data content had to be reestablished and do not require a FRU replacement unless the error is persistent. When one of these errors occurs, system customization information (the boot list, for example) has been lost, and the system may need to be re-configured.

If the error is persistent, replace the service processor card. Use the following table to determine the part number for the field replaceable unit (FRU):

CCIN or FFC	Type and model	Part number	Description	Location code
	8203-E4A, 9407-M15, 9408-M25	42R7898	System backplane (integrated service processor card)	U n-P1
	8204-E8A, 9409-M50	10N9369	System backplane, (integrated service processor card)	U n-P1
	9406-MMA, 9117-MMA	10N8752	Service processor card	U n-P1-C11

This ends the procedure.

FWNVR2

Look here for information about FWNVR2 symbolic FRU.

If the error is persistent, replace the service processor. Use the following table to determine the part number for the field replaceable unit (FRU):

CCIN or FFC	Type and model	Part number	Description	Location code
	8203-E4A, 9407-M15, 9408-M25	42R7898	System backplane (integrated service processor card)	Un-P1
	8204-E8A, 9409-M50	10N9369	System backplane, (integrated service processor card)	Un-P1
	9406-MMA, 9117-MMA	10N8752	Service processor card	Un-P1-C11

This ends the procedure.

FWNVR3

Look here for information about FWNVR3 symbolic FRU.

Execution of a command line within the nvram configuration variable **nvramrc(script)** resulted in a "throw" being executed.

This script can be modified by the system firmware SMS utilities, the operating system, PCI adapter ROM code or utility, or an operator (via the open firmware script editing command *nvedit*).

It might not be possible to resolve the problem without a detailed analysis of the NVRAM script, the current system configuration, and the device tree contents.

1. This problem can be caused by a SCSI adapter whose SCSI bus ID has changed from the default setting and the adapter no longer appears in the system. This can be caused either by removing a SCSI adapter, or a problem with a SCSI adapter.
 - a. On the SMS main menu, select **option 5**, Change SCSI settings.
 - b. On the SCSI utilities menu, select **option 2**, Change SCSI ID.
 - 1) Verify the list of SCSI controllers/adapters. If the list is not correct, suspect a problem with adapters that are installed but not listed.
 - 2) Select the option to "Save" the configuration information.
 - 3) Restart the system.

- c. If the problem persists, boot the operating system and verify the SCSI bus IDs of the SCSI controllers, and correct if necessary.
 - d. Restart the system.
2. Contact your service support representative for further assistance.

This ends the procedure.

FWPCI1

Look here for information about FWPCI1 symbolic FRU.

If you receive symbolic FRU FWPCI1, do one of the following:

- If the location code identifies a slot:
 1. Check for adapter firmware updates. Apply the update if one is available.
 2. Replace the adapter. See Managing PCI adapters for PCI adapter FRU part numbers.
 3. Check for platform firmware updates. Apply the update if one is available.
- If the location code identifies an I/O backplane:
 1. Check for platform firmware updates. Apply the update if one is available.
 2. Replace the I/O backplane (system backplane on certain systems). Use the following table to determine the part number for the field replaceable unit (FRU):

CCIN or FFC	Type and model	Part number	Description	Location code
	8203-E4A, 9407-M15, 9408-M25	42R7898	System backplane	Un-P1
	8204-E8A, 9409-M50	10N9369	System backplane	Un-P1
	9406-MMA, 9117-MMA	42R7352	I/O backplane	Un-P1
	5790, 7311-D11	80P6626	I/O backplane	Un-P1
	0595, 5095, 7311-D20	39J0515	I/O backplane	Un-P1
	5796, 7314-G30	See Finding parts, locations, and addresses.	I/O backplane	Un-P1
	5094	39J3058	I/O backplane	Un-CB1

3. Call service support.

This ends the procedure.

FWPCI2

Look here for information about FWPCI2 symbolic FRU.

If you receive FWPCI2 symbolic FRU perform the following procedure.

1. If the location code identifies a slot:
 - a. Check for adapter firmware updates. Apply the update if one is available.
 - b. Check the cabling to the adapter (in particular, the adapters that have serial ports). Serial ports might require null modems or special cabling configurations to avoid connecting driver outputs together. This may create a PCI power problem and force the adapter to be de-configured.
 - c. Use the hot plug service aid to re-seat the adapter specified by the location code. If re-seating the adapter fixes the problem, perform the repair checkout procedure. If the problem is not resolved, go to the next step.

- d. Use the hot plug task to move the adapter to another slot (behind another PCI bridge). PCI adapter placement for machine type 820x and 91xx identifies the PCI Host Bridges (PHB) and associated slots.
2. If the adapter is successfully re-configured in the new slot (behind another PCI host bridge), the slot in which the adapter was originally plugged is bad. Replace the I/O backplane (system backplane on certain systems) assembly that contains the slot in which the adapter was plugged, use the following table to determine the part number for the field replaceable unit (FRU):

CCIN or FFC	Type and model	Part number	Description	Location code
	8203-E4A, 9407-M15, 9408-M25	42R7898	System backplane	Un-P1
	8204-E8A, 9409-M50	10N9369	System backplane	Un-P1
	9406-MMA, 9117-MMA	42R7352	I/O backplane	Un-P1
	5790, 7311-D11	80P6626	I/O backplane	Un-P1
	0595, 5095, 7311-D20	39J0515	I/O backplane	Un-P1
	5796, 7314-G30	See Finding parts, locations, and addresses.	I/O backplane	Un-P1
	5094	39J3058	I/O backplane	Un-CB1

3. Replace the adapter if the adapter does not successfully re-configure into the new slot. **This ends the procedure.**
4. If the adapter is successfully re-configured in the new slot (behind another PCI host bridge), the slot in which the adapter was originally plugged is bad, replace the I/O backplane (system backplane on certain systems), use the following table to determine the part number for the field replaceable unit (FRU):

CCIN or FFC	Type and model	Part number	Description	Location code
	8203-E4A, 9407-M15, 9408-M25	42R7898	System backplane	Un-P1
	8204-E8A, 9409-M50	10N9369	System backplane	Un-P1
	9406-MMA, 9117-MMA	42R7352	I/O backplane	Un-P1
	5790, 7311-D11	80P6626	I/O backplane	Un-P1
	0595, 5095, 7311-D20	39J0515	I/O backplane	Un-P1
	5796, 7314-G30	See Finding parts, locations, and addresses.	I/O backplane	Un-P1
	5094	39J3058	I/O backplane	Un-CB1

5. Replace the adapter if the adapter does not successfully re-configure into the new slot. **This ends the procedure.**

FWPCI3

Look here for information about FWPCI3 symbolic FRU.

If you receive symbolic FRU FWPCI3, do one of the following procedures.

1. If the location code identifies a PCI card slot:

- a. Check the cabling to the adapter (in particular, the adapters that have system ports). System ports might require null modems or special cabling configurations to avoid connecting driver outputs together. This might create a PCI power problem and force the adapter to be de-configured.
- b. Move the adapter to another slot (behind another PCI bridge). PCI adapter placement for machine type 820x and 91xx identifies the PCI Host Bridges (PHB) and associated slots.
- c. Check for adapter firmware updates. Apply the update if one is available.
- d. Replace the adapter. See Managing PCI adapters for PCI adapter FRU part numbers.
- e. Check for platform firmware updates. Apply the update if one is available.
- f. Replace the I/O backplane (system backplane on certain systems), use the following table to determine the part number for the field replaceable unit (FRU):

CCIN or FFC	Type and model	Part number	Description	Location code
	8203-E4A, 9407-M15, 9408-M25	42R7898	System backplane	Un-P1
	8204-E8A, 9409-M50	10N9369	System backplane	Un-P1
	9406-MMA, 9117-MMA	42R7352	I/O backplane	Un-P1
	5790, 7311-D11	80P6626	I/O backplane	Un-P1
	0595, 5095, 7311-D20	39J0515	I/O backplane	Un-P1
	5796, 7314-G30	See Finding parts, locations, and addresses.	I/O backplane	Un-P1
	5094	39J3058	I/O backplane	Un-CB1

2. If the location identifies an I/O backplane:
 - a. Check for platform firmware updates. Apply the update if one is available.
 - b. Replace the I/O backplane (system backplane on certain systems), use the following table to determine the part number for the field replaceable unit (FRU):

CCIN or FFC	Type and model	Part number	Description	Location code
	8203-E4A, 9407-M15, 9408-M25	42R7898	System backplane	Un-P1
	8204-E8A, 9409-M50	10N9369	System backplane	Un-P1
	9406-MMA, 9117-MMA	42R7352	I/O backplane	Un-P1
	5790, 7311-D11	80P6626	I/O backplane	Un-P1
	0595, 5095, 7311-D20	39J0515	I/O backplane	Un-P1
	5796, 7314-G30	See Finding parts, locations, and addresses.	I/O backplane	Un-P1
	5094	39J3058	I/O backplane	Un-CB1

This ends the procedure.

FWPCI4

Look here for information about FWPCI4 symbolic FRU.

If you receive the FWPCI4 symbolic FRU, perform the following.

1. If a location code is associated with the checkpoint, replace the adapter identified by the location code.
2. If no location code is specified, go to PFW1542: I/O problem isolation procedure.

This ends the procedure.

FWPCI5

Look here for information about FWPCI5 symbolic FRU.

If you receive symbolic FRU FWPCI5, perform the following procedure:

1. Is a location code associated with the checkpoint?
 - **No:** Go to PFW1548: Memory and processor subsystem problem isolation procedure. **This ends the procedure.**
 - **Yes:** Continue with the next step.
2. Replace the following, one at a time, until the problem is resolved:
 - a. The FRU identified by the location code, see the system unit service guide for the FRU part numbers.
 - b. I/O backplane, use the following table to determine the part number for the field replaceable unit (FRU):

CCIN or FFC	Type and model	Part number	Description	Location code
	8203-E4A, 9407-M15, 9408-M25	42R7898	System backplane	Un-P1
	8204-E8A, 9409-M50	10N9369	System backplane	Un-P1
	9406-MMA, 9117-MMA	42R7352	I/O backplane	Un-P1
	5790, 7311-D11	80P6626	I/O backplane	Un-P1
	0595, 5095, 7311-D20	39J0515	I/O backplane	Un-P1
	5796, 7314-G30	See Finding parts, locations, and addresses.	I/O backplane	Un-P1
	5094	39J3058	I/O backplane	Un-CB1

This ends the procedure.

FWPCI6

Look here for information about FWPCI6 symbolic FRU.

The last character of the progress code (checkpoint) in which the system is hanging indicates which PCI slot the system was probing at the time the hang occurred. For example, E251 indicates PCI slot 1, E252 indicates slot 2, and so on.

For the PCI slot identified by the progress code, perform the following procedure:

1. Power down the system.
2. Reseat the adapter in the specified slot, then power up the system. Does the problem occur again?
 - **Yes:** Go to the next step.
 - **No:** This ends the procedure.
3. Power down the system and remove the adapter from the specified slot, then power on the system. Does the problem occur again?

- **No:** Replace the adapter that you removed. See Managing PCI adapters for PCI adapter FRU part numbers.
- **Yes:** Replace the backplane that contains the PCI adapter slots. Use the following table to determine the part number for the field replaceable unit (FRU):

CCIN or FFC	Type and model	Part number	Description	Location code
	8203-E4A, 9407-M15, 9408-M25	42R7898	System backplane	Un-P1
	8204-E8A, 9409-M50	10N9369	System backplane	Un-P1
	9406-MMA, 9117-MMA	42R7352	I/O backplane	Un-P1
	5790, 7311-D11	80P6626	I/O backplane	Un-P1
	0595, 5095, 7311-D20	39J0515	I/O backplane	Un-P1
	5796, 7314-G30	See Finding parts, locations, and addresses.	I/O backplane	Un-P1
	5094	39J3058	I/O backplane	Un-CB1

This ends the procedure.

FWPTR

Values normally found in nonvolatile storage that point to the location of an operating system were not found.

This can happen for two reasons: either your operating system doesn't support storing the values, or some events occurred that caused the system to lose non-volatile storage information (drainage or replacement of the battery). If you are running AIX^(R), this information can be reconstructed by running the bootlist command specifying the device that the operating system is installed on. Please refer to your AIX documentation for the syntax and usage of the bootlist command.

In order to boot the operating system so that the above-mentioned values can be reconstructed, power the system down and power it back up again. This should cause the system to look for the operating system in the device contained in the custom boot list or in the default boot list, depending on the condition of the system. If this is not successful, modify the boot sequence (also known as the boot list) to include devices that are known to contain a copy of the operating system. This can be accomplished by using the System Management Services menus. For example, select a hard disk known to have a copy of the operating system as the first and only device in the boot sequence (boot list) and boot the system.

This ends the procedure.

FWPWD

Look here for information about FWPWD symbolic FRU.

If you received the symbolic FRU FWPWD, do the following:

You should be able to see the system prompt on the hardware console.

If your server has an attached console, but the console display is not functioning correctly, refer to the the documentation for the display. If you cannot adjust the display, replace the display with one that is known to be functional.

This ends the procedure.

FWRIPL

The FWRIPL procedures can help if a system or a partition will not boot.

If a supported adapter is installed, perform the following:

1. Replace the adapter. For adapter FRU part numbers, see Managing PCI adapters.
2. Replace the I/O backplane (system backplane on certain systems) in the unit in which the adapter is plugged. Use the following table to determine the part number for the field replaceable unit (FRU):

CCIN or FFC	Type and model	Part number	Description	Location code
	8203-E4A, 9407-M15, 9408-M25	42R7898	System backplane	Un-P1
	8204-E8A, 9409-M50	10N9369	System backplane	Un-P1
	9406-MMA, 9117-MMA	42R7352	I/O backplane	Un-P1
	5790, 7311-D11	80P6626	I/O backplane	Un-P1
	0595, 5095, 7311-D20	39J0515	I/O backplane	Un-P1
	5796, 7314-G30	See Finding parts, locations, and addresses.	I/O backplane	Un-P1

If there are no supported LAN adapters installed in a full system partition, install one and reboot the system. If a supported LAN adapter is not assigned to the partition in a server running multiple partitions, deactivate the partition, assign a supported LAN adapter to the partition, then reactivate the partition.

This ends the procedure.

FWSCSI1

Look here for information about FWSCSI1 symbolic FRU.

If you receive the symbolic FRU FWSCSI1, before replacing any system components do the following:

1. Ensure that the controller and each device on the SCSI bus is assigned a unique SCSI ID.
2. Ensure that the SCSI bus is properly terminated.
3. Ensure that the SCSI signal and power cables are securely connected and are not damaged.

The location code information is required to identify the ID of SCSI device failures as well as to indicate the location of the controller to which the device is attached. Check the system error logs to determine the location code information associated with the error code.

1. Replace the SCSI device. See Finding parts, locations, and addresses for SCSI device FRU part numbers.
2. Replace the SCSI cable. See Finding parts, locations, and addresses for SCSI cabling FRU part numbers.
3. Replace the SCSI controller. See Managing PCI adapters for SCSI PCI adapter FRU part numbers. If the failure is on an integrated SCSI controller, replace the I/O backplane (system backplane on certain systems), use the following table to determine the part number for the field replaceable unit (FRU):

CCIN or FFC	Type and model	Part number	Description	Location code
	9406-MMA, 9117-MMA	42R7352	I/O backplane	Un-P1

This ends the procedure.

FWSCSI2

Look here for information about FWSCSI2 symbolic FRU.

If you receive the symbolic FRU FWSCSI2, before replacing any system components do the following:

1. Ensure that the controller and each device on the SCSI bus is assigned a unique SCSI ID.
2. Ensure that the SCSI bus is properly terminated.
3. Ensure that the SCSI signal and power cables are securely connected and are not damaged.

The location code information is required to identify the ID of SCSI device failures as well as to indicate the location of the controller to which the device is attached. Check the system error logs to determine the location code information associated with the error code.

1. Replace the media (if it is a device with removable media).
2. Replace the SCSI device. See Finding parts, locations, and addresses for SCSI device FRU part numbers.

This ends the procedure.

FWSCSI3

Look here for information about FWSCSI3 symbolic FRU.

If you receive the symbolic FRU FWSCSI3, before replacing any system components do the following:

1. Ensure that the controller and each device on the SCSI bus is assigned a unique SCSI ID.
2. Ensure that the SCSI bus is properly terminated.
3. Ensure that the SCSI signal and power cables are securely connected and are not damaged.

The location code information is required to identify the ID of SCSI device failures as well as to indicate the location of the controller to which the device is attached. Check the system error logs to determine the location code information associated with the error code.

1. Replace the SCSI device. See Finding parts, locations, and addresses for SCSI device FRU part numbers.

This ends the procedure.

FWSCSI4

Look here for information about FWSCSI4 symbolic FRU.

If you receive the symbolic FRU FWSCSI4, before replacing any system components do the following:

1. Ensure that the controller and each device on the SCSI bus is assigned a unique SCSI ID.
2. Ensure that the SCSI bus is properly terminated.
3. Ensure that the SCSI signal and power cables are securely connected and are not damaged.

The location code information is required to identify the ID of SCSI device failures as well as to indicate the location of the controller to which the device is attached. Check the system error logs to determine the location code information associated with the error code.

1. Replace the media (if a device with removable media).
2. Replace the SCSI device. See Finding parts, locations, and addresses for SCSI device FRU part numbers.

This ends the procedure.

FWSCSI5

Look here for information about FWSCSI5 symbolic FRU.

If you receive the symbolic FRU FWSCSI5, before replacing any system components do the following:

1. Ensure that the controller and each device on the SCSI bus is assigned a unique SCSI ID.
2. Ensure that the SCSI bus is properly terminated.
3. Ensure that the SCSI signal and power cables are securely connected and are not damaged.

The location code information is required to identify the ID of SCSI device failures as well as to indicate the location of the controller to which the device is attached. Check the system error logs to determine the location code information associated with the error code.

1. Replace the SCSI device. See Finding parts, locations, and addresses for SCSI device FRU part numbers.
2. Replace the SCSI cable. See Finding parts, locations, and addresses for SCSI cabling FRU part numbers.
3. If the missing SCSI devices are connected to the same backplane, replace the SCSI backplane. Use the following table to determine the part number for the field replaceable unit (FRU):

CCIN or FFC	Type and model	Part number	Description	Location code
	9406-MMA, 9117-MMA	42R6780	Disk drive backplane	Un-P3

4. Replace the SCSI controller. See Managing PCI adapters for SCSI PCI adapter FRU part numbers. If the failure is on an integrated SCSI controller, replace the I/O backplane, use the following table to determine the part number for the field replaceable unit (FRU):

CCIN or FFC	Type and model	Part number	Description	Location code
	9406-MMA, 9117-MMA	42R7352	I/O backplane	Un-P1

This ends the procedure.

FWSCSIH

Look here for information about SCSIH symbolic FRU.

If you receive symbolic FRU FWSCSIH, do one the following:

- If a location code is available, follow the repair actions listed for error code BA090001 (see FWSCSI1).
- If no location code is available, go to PFW1548: Memory and processor subsystem problem isolation procedure.

This ends the procedure.

FWVTHMC

Look here for information about FWVTHMC symbolic FRU.

If you received symbolic FRU FWVTHMC, perform the following procedure:

1. The partition firmware is waiting for a virtual terminal to be opened on the HMC. Open a virtual terminal.
2. If a virtual terminal is open, the user might have entered a CTRL-S key sequence to stop the scrolling of data off the screen. If this is the case, enter a CTRL-Q key sequence to resume scrolling.
3. Check the ethernet connection between the HMC and the managed system.

4. Reboot the HMC.
5. There might be a hardware problem with the HMC. Refer to Hardware Management Console models 7042-CR4, 7042-C06, and 7042-C07 service.
6. There might be a hardware problem with the service processor in the managed system. Check the service action event log in Service Focal Point for error codes that indicate a problem with the ethernet ports on the service processor. Take the appropriate actions based on the error codes that you find.

This ends the procedure.

HCA

The failing component is the 12X host channel adapter (HCA).

Do you have a location code for this FRU?

- **No:** Go to SICNTRL to determine the location of the HCA and replace it.
- **Yes:** Replace the 12X HCA.

Use the following table to determine the part number for the field replaceable unit (FRU):

CCIN or FFC	Type and model	Part number	Description	Location code
	8203-E4A	44V4645	GX Dual-Port 12X HCA	Un-P1-Cx
	8204-E8A	10N9529	GX Dual-Port 12X HCA	Un-P1-Cx
	9406-MMA, 9117-MMA	42R6849	GX Dual-Port 12X HCA	Un-P1-Cx
	7314-G30	10N8782	GX Dual-Port 12X HCA	Un-P1-C7

HEA

The failing component is the host ethernet adapter.

The host ethernet adapter comprises two parts:

1. VPD passthrough card
2. I/O backplane

Replace these parts in the order shown. Use the following table to determine the part number for the field replaceable unit (FRU):

Table 4.

CCIN or FFC	Type and Model	Part number	Description	Location code
	8203-E4A	42R7898	System backplane	Un-P1
	8203-E4A	42R7898	System backplane	Un-P1
	8204-E8A	10N9369	System backplane	Un-P1
	9406-MMA, 9117-MMA	42R6775	Passthrough card (VPD, system ports, SPCN, 1 GB Ethernet)	Un-P1-C10
	9406-MMA, 9117-MMA	42R7000	Passthrough card (VPD, system ports, SPCN, 1 GB Ethernet Quad)	Un-P1-C10

Table 4. (continued)

CCIN or FFC	Type and Model	Part number	Description	Location code
	9406-MMA, 9117-MMA	42R7358	Passthrough card (VPD, system ports, SPCN, 10 GB Ethernet Long Range)	Un-P1-C10
	9406-MMA, 9117-MMA	42R7352	I/O backplane	Un-P1

HMCLIC

Firmware on the Hardware Management Console (HMC) must be replaced.

Refer to Hardware Management Console models 7042-CR4, 7042-C06, and 7042-C07 service to replace the HMC firmware.

HMCMTWK

Multiple connections to peer HMCs have been lost.

1. Perform the following from the HMC reporting the connection errors:
 - a. In the navigation area, click **HMC Management**
 - b. In the right hand pane, click **View Network Topology**.
 - c. Are the peer HMCs with the missing connection present in the topology?
 - **No:** Continue with the next step.
 - **Yes:** The problem was temporary and has resolved itself. **This ends the procedure.**
2. Is the HMC that reported the connection errors also reporting a hardware error with a network adapter?
 - **No:** Continue with the next step.
 - **Yes:** Service this network adapter error. **This ends the procedure.**
3. Verify that each peer HMC with a missing connection is powered on and that its ethernet connections are secure and functioning. Does the problem persist?
 - **No: This ends the procedure.**
 - **Yes:** Continue with the next step.
4. Have the customer verify that their network is operating properly. If the problem still persists, contact your next level of support.

This ends the procedure.

HMCNTWK

A connection to a peer HMC (indicated in the location code) has been lost.

1. Perform the following from the HMC reporting the connection error:
 - a. In the navigation area, click **HMC Management**.
 - b. In the right hand pane, click **View Network Topology**.
 - c. Is the peer HMC with the missing connection present in the topology?
 - **No:** Continue with the next step.
 - **Yes:** The problem was temporary and has resolved itself. **This ends the procedure.**
2. Verify that the peer HMC with the missing connection is powered on and that its ethernet connections are secure and functioning. Does the problem persist?
 - **No: This ends the procedure.**

- **Yes:** Continue with the next step.
3. Is either the HMC that reported the problem or the peer HMC with the missing connection reporting a hardware error with a network adapter?
 - **No:** Continue with the next step.
 - **Yes:** Service this network adapter error. **This ends the procedure.**
 4. Have the customer verify that their network is operating properly. If the problem still persists, contact your next level of support.

This ends the procedure.

HSL1

This is a standard copper HSL/RIO cable at both ends.

Diagnostic code cannot determine the length of the cable. Go to HSL_LNK and follow the appropriate instructions.

This ends the procedure.

HSL1_UN

This is a standard copper HSL/RIO cable at the end where an error was detected.

Diagnostic code cannot determine the length of the cable, or the type of connector at the other end. Go to HSL_LNK and follow the appropriate instructions.

This ends the procedure.

HSL2

This is an HSL2/RIO-G copper HSL/RIO cable at both ends.

Diagnostic code cannot determine the length of the cable. Go to HSL_LNK and follow the appropriate instructions.

This ends the procedure.

HSL2_01

This is an HSL2/RIO-G copper HSL/RIO cable at both ends.

The 01 value indicates the cable is 1 meter long. Go to HSL_LNK and follow the appropriate instructions.

This ends the procedure.

HSL2_03

This is an HSL2/RIO-G copper HSL/RIO cable at both ends.

The 03 value indicates the cable is 3 meters long. Go to HSL_LNK and follow the appropriate instructions.

This ends the procedure.

HSL2_08

This is an HSL2/RIO-G copper HSL/RIO cable at both ends.

The 08 value indicates the cable is 8 meters long. Go to HSL_LNK and follow the appropriate instructions.

This ends the procedure.

HSL2_10

This is an HSL2/RIO-G copper HSL/RIO cable at both ends.

The 10 value indicates the cable is 10 meters long. Go to HSL_LNK and follow the appropriate instructions.

This ends the procedure.

HSL2_15

This is an HSL2/RIO-G copper HSL/RIO cable at both ends.

The 15 value indicates the cable is 15 meters long. Go to HSL_LNK and follow the appropriate instructions.

This ends the procedure.

HSL2_17

This is an HSL2/RIO-G copper HSL/RIO cable at both ends.

The 17 value indicates that the cable is 1.75 meters long. Go to HSL_LNK and follow the appropriate instructions.

This ends the procedure.

HSL2_25

This is an HSL2/RIO-G copper HSL/RIO cable at both ends.

The 25 value indicates that the cable is 2.5 meters long. Go to HSL_LNK and follow the appropriate instructions.

This ends the procedure.

HSL2_xx

This is an HSL2/RIO-G copper HSL/RIO cable at both ends.

The xx value indicates the cable length in meters. Go to HSL_LNK and follow the appropriate instructions.

This ends the procedure.

HSL_I2

The failing item is an HSL2/RIO-G interposer card on machine type 9406.

This interposer card is for copper HSL2/RIO-G cable connectors (black) on the system unit planar in location C08 or C09. Diagnostic code will attempt to include the card's location with the FRU in the serviceable event view. Go to HSL_LNK and follow the appropriate instructions.

This ends the procedure.

HSL_I3

The failing item is an HSL/RIO interposer card on machine type 9406.

This interposer card is for optical HSL/RIO cable connectors on the system unit planar in location C08 or C09. Diagnostic code will attempt to include the card's location with the FRU in the serviceable event view. Go to HSL_LNK and follow the appropriate instructions.

This ends the procedure.

HSL_I4

The failing item is an HSL-2/RIO-2 interposer card on a 7040-61D expansion unit.

This interposer card is for copper HSL-2 or RIO-2 cable connectors (black) on the expansion unit backplane in location -P1-(Riser) or -P2-(Riser). Diagnostic code will attempt to include the card's location with the FRU in the serviceable event view. Go to HSL_LNK and follow the appropriate instructions.

This ends the procedure.

HSL_I5

The failing item is a 12X interposer (riser) card on a 7314-G30 expansion unit or a 5796 expansion unit.

This interposer (riser) card is for 12X cable connectors on the expansion unit backplane in location Un-P1-C7. The diagnostic code will attempt to include the card's location code with the FRU in the serviceable event view. Go to HSL_LNK and follow the appropriate instructions.

This ends the procedure.

HSL_I

This is an HSL/RIO interposer card for copper HSL2/RIO-G (black) connections or optical HSL/RIO connections.

Diagnostic code cannot determine the type of interposer card. Go to HSL_LNK and follow the appropriate instructions.

This ends the procedure.

HSL_IB

This is a 12X cable (green connectors).

Go to HSL_LNK and follow the appropriate instructions.

This ends the procedure.

HSL_Ix

This is an HSL/RIO interposer card for copper HSL2/RIO-G (black) connections or optical HSL/RIO connections.

The "x" value indicates the type of interposer card. Go to HSL_LNK and follow the appropriate instructions.

This ends the procedure.

HSL_LNK

The failing component is the RIO/HSL/12X connection.

Attention: When a RIO/HSL cable is disconnected, it might result in a lost connection between the units even after the cable is reconnected. To fix this problem, you need to power off and power on the unit with the locked RIO/HSL connection. This problem does not occur with 12X cables.

Note: If question marks (???) appear at the end of the location code, then the port could not be determined. Use the location code associated with the other end of the cable. If question marks appear for both port locations, use the isolation procedures suggested in the reference code information for this SRC.

1. Choose from the following:

- If you were sent to this procedure from another symbolic field replaceable unit (FRU), locate that FRU in Table 1 to see the description of the RIO/HSL/12X FRU. Then continue with the next step for more information about the FRU.
- If you are working with this symbolic FRU in the FRU list, the failing component is a RIO/HSL/12X connection. Diagnostic code could not determine what kind of hardware was involved. The RIO/HSL/12X hardware can be any of the following:
 - Cable
 - Embedded RIO/HSL/12X link in a FRU (a backplane, for example)
 - RIO/HSL/12X interposer card

The RIO/HSL/12X link is on or between the other FRU or FRUs listed for the reference code. Continue with the next step.

Table 5. RIO/HSL symbolic FRUs

RIO/HSL FRU	Description
HSL_OPT	This is an optical RIO/HSL cable. When exchanging optical RIO/HSL cables, use the optical cleaning kit and procedures. See symbolic FRU OPT_CLN for details. If an interposer card is called for, be sure the interposer type matches the cable type (optical or copper).
HSL1	There is a standard copper RIO/HSL cable at both ends (yellow connectors).
HSL1_UN	There is a standard copper RIO/HSL cable (yellow connector) at the detecting end, and an unknown connector type at the other end.
HSL2	There is a copper HSL2/RIO-G cable at both ends (black connectors), but the length of the cable could not be sensed.
HSL2_xx	There is a copper HSL2/RIO-G cable at both ends (black connectors). Use the <i>xx</i> value to determine the cable length from this list: <ul style="list-style-type: none"> • HSL2_01 = 1 meter HSL2 cable • HSL2_03 = 3 meter HSL2 cable • HSL2_08 = 8 meter HSL2 cable • HSL2_10 = 10 meter HSL2 cable • HSL2_15 = 15 meter HSL2 cable • HSL2_17 = 1.75 meter HSL2 cable • HSL2_25 = 2.5 meter HSL2 cable

Table 5. RIO/HSL symbolic FRUs (continued)

RIO/HSL FRU	Description
HSL_IB	This is a 12X cable (green connectors)
HSL_I	There is a RIO/HSL interposer card for HSL/RIO cables (yellow connectors), HSL2/RIO-G cables (black connectors), or optical cables. The interposer card type could not be sensed.
HSL_I2 HSL_I3 HSL_I4	There is a RIO/HSL interposer card for HSL/RIO cables (yellow connectors), HSL2/RIO-G cables (black connectors), or RIO/HSL optical cables, or 12X cables. Use the <i>x</i> value to determine the interposer card type from this list: <ul style="list-style-type: none"> • HSL_I2 = Copper HSL2/RIO-G interposer card for HSL2/RIO-G cable connectors (black) in the system unit backplane position C08 or C09 of machine type 9406 model 825. • HSL_I3 = Optical HSL/RIO interposer card for optical RIO/HSL cables in system unit backplane position C08 or C09 of machine type 9406. • HSL_I4 = HSL2/RIO-G interposer/riser card on a 7040-61D I/O unit in location -P1-(Riser) or -P2-(Riser). • HSL_I5 = 12X interposer, passthrough or riser card on an I/O enclosure that attaches with 12X cables.
INT_12X	This is an internal 12X connection in an enclosure. Some units have internal 12X connections to or from 12X adapters in the unit. The internal connection might be contained in a single FRU that has multiple 12X adapters or the internal connection might be part of a FRU to FRU connection in the unit where each FRU has one or more 12X adapters. For the location code of this FRU in a serviceable event error log, diagnostic firmware will provide as much information about the location of the 12X connection as possible for the error.

2. Choose from the following options:

- If you are working from the serviceable event view, the location code or FRU description in the view will help determine the actual RIO/HSL/12X hardware to exchange. Continue with the next step.
- If you are not working from the serviceable event view, or the view does not have a location code or better FRU description, then determine the location code of other FRUs in the FRU list for the error. Then continue with the next step.

3. Use the location code and the information from the preceding table to determine the machine type, model, or unit feature involved in the error. If necessary, use the location code for other FRUs listed in the FRU list for this error to determine the failing RIO/HSL/12X connection and any related FRUs that are part of that connection. Use the following table to determine the part number for the FRU:

Note: If you exchange all of the FRUs in the FRU list, but the problem still exists, contact your next level of support. You might be directed to exchange additional RIO/HSL/12X FRUs. Additional RIO/HSL/12X FRUs has more information about RIO/HSL/12X FRUs on specific models and I/O enclosures. Use this section when you are directed by your next level of support.

Table 6. RIO/HSL/12X FRU parts

CCIN or FFC	Type and model	Part number	Description	Location code
	8203-E4A	See RIO/HSL/12X cables.	RIO/HSL cables	Un-P1-Cx-Ty
	8203-E4A	10N9982	RIO-2/HSL-2 adapter	Un-P1-Cx
	8203-E4A	42R7898	System backplane	Un-P1
	8204-E8A	See RIO/HSL/12X cables.	RIO/HSL cables	Un-P1-Cx-Ty
	8204-E8A	10N6859	RIO-2/HSL-2 adapter	Un-P1-Cx
	8204-E8A	10N9369	System backplane	Un-P1
1816	9119-FHA	See Finding parts, locations, and addresses.	Dual-port 12X HCA	Un-Pm-C37, Un-Pm-C38, Un-Pm-C39, Un-Pm-C40
295B	9119-FHA	See Finding parts, locations, and addresses.	Dual-port 12X HCA	Un-Pm-C37, Un-Pm-C38, Un-Pm-C39, Un-Pm-C40
	9119-FHA	See RIO/HSL/12X cables.	12X cables	Un-Pm-Cx-Ty
	9406-MMA, 9117-MMA	See RIO/HSL/12X cables.	RIO/HSL cables	Un-P1-Cx-Ty
1800	9406-MMA, 9117-MMA	39J0792	RIO/HSL-2 adapter	Un-P1-Cx
	9406-MMA, 9117-MMA	42R7352	I/O backplane	Un-P1
28FF	5790, 7311-D11	03N5633	RIO/HSL adapter	Un-P1-C7
	5790, 7311-D11	80P6626	I/O backplane	Un-P1
2887	0595, 5095, 7311-D20	39J0527	RIO/HSL-2 adapter	Un-P1-C05
28E7	0595, 5095, 7311-D20	39J0523	RIO/HSL adapter	Un-P1-C05
	0595, 5095, 7311-D20	39J0515	I/O backplane	Un-P1
520A	5796, 7314-G30	10N8782	Dual-port 12X channel attach adapter	Un-P1-C7
	5796, 7314-G30	10N7677	I/O backplane	Un-P1
50A2	5802, 5877	See Finding parts, locations, and addresses.	I/O Backplane	Un-P1
50A2	5803, 5873	See Finding parts, locations, and addresses.	I/O Backplane	Un-P1, Un-P2
	5802, 5877	See RIO/HSL/12X cables.	12X cables	Un-P1-Ty
	5803, 5873	See RIO/HSL/12X cables.	12X cables	Un-P1-Ty, Un-P2-Ty

Use the following table to determine FRU part numbers for RIO/HSL cables. To locate part numbers for GX Dual-Port 12X cables and any cables that are not listed here, see Site and hardware planning.

Table 7. Cable part numbers

Description	Part number
RIO/HSL cable (3 meters) (1460)	44L0005
RIO/HSL cable (6 meters) (1461)	97H7490
RIO/HSL cable (15 meters) (1462)	04N7014
RIO/HSL optical cable (6 meters) (1470)	21P5014
RIO/HSL optical cable (30 meters) (1471)	21P5015
RIO/HSL optical cable (100 meters) (1472)	21P5016
RIO/HSL optical cable (250 meters) (1473)	21P6326
RIO/HSL to RIO/HSL-2 (6 meters) (1474)	21P5477
RIO/HSL to RIO/HSL-2 (10 meters) (1475)	21P5458
RIO/HSL-2 (1.2 meters) (1481, 3146)	21P5454
RIO/HSL-2 (1.75 meters) (1307, 3156)	00P5238
RIO/HSL-2 (1.75 meters) (1308, 3158)	00P5239
RIO/HSL-2 (3.5 meters) (1482, 3147)	53P2676
RIO/HSL-2 (10 meters) (1483, 3148)	21P5456
RIO/HSL-2 (15 meters) (1485)	21P5457
RIO/HSL (8 meters) (3170)	12R7503
12X cable (1.5 meters) (1862)	See Site and hardware planning.
12X cable (2.5 meters) (1863)	See Site and hardware planning.
12X cable (3.0 meters) (1864)	See Site and hardware planning.
12X cable (8.0 meters) (1865)	See Site and hardware planning.

Additional RIO/HSL/12X FRUs

The following are RIO/HSL/12X FRUs by model or unit type. For the model or unit type you are working on, there might be additional RIO/HSL/12X FRUs which were not listed in the FRU list of the error. Under the direction of your next level of support, you can try exchanging the additional FRUs.

1. In the following table, locate the unit type(s) on which you are working. Exchange the indicated RIO/HSL/12X loop connections (external or embedded) or RIO/HSL/12X interposer card.

Table 8. RIO/HSL/12X FRU parts

CCIN or FFC	Type and model	Part number	Description	Location code
2886	5094, 5096, 5294, 5296	39J0669	HSL (optical) I/O bridge adapter	Un-CB1-C10
2887	5094, 5096, 5294, 5296	39J0527	HSL I/O bridge adapter	Un-CB1-C10
28E7	5094, 5096, 5294, 5296	39J0523	HSL-2 I/O bridge adapter	Un-CB1-C10
28FF	5790, 7311-D11	03N5633	RIO/HSL adapter	Un-P1-C7
2886	0595, 5095	39J0669	HSL (optical) I/O bridge adapter	Un-P1-C5
2887	0595, 5095, 7311-D20	39J0527	RIO/HSL I/O bridge adapter	Un-P1-C5
28E7	0595, 5095, 7311-D20	39J0523	RIO/HSL-2 I/O bridge adapter	Un-P1-C5

Table 8. RIO/HSL/12X FRU parts (continued)

CCIN or FFC	Type and model	Part number	Description	Location code
520A	5796, 7314-G30	10N8782	Dual-port 12X adapter	Un-P1-C7
	1519	42R4468	Integrated xSeries Adapter	

2. Did the exchange correct the error?

- **Yes:** The FRU you just replaced was the failing item.

This ends the procedure.

- **No:** Call your next level of support.

This ends the procedure.

HSL_OPT

This is an optical HSL/RIO cable.

When connecting or disconnecting these cables, use the optical cleaning kit described in OPT_CLN. Go to HSL_LNK and follow the appropriate instructions.

This ends the procedure.

HSLH

This is a hybrid HSL/RIO to HSL2/RIO-G copper cable.

One end of the cable has an HSL/RIO yellow connector and the other end has an HSL2/RIO-G black connector. Diagnostic code cannot determine the length of the cable. Diagnostic code will attempt to determine the location codes of cable ports at each end of the cable. Go to HSL_LNK and follow the appropriate instructions.

This ends the procedure.

HSLH_06

This is a hybrid HSL/RIO to HSL2/RIO-G copper cable.

One end of the cable has an HSL/RIO yellow connector and the other end has an HSL2/RIO-G black connector. The "06" value indicates the length of the cable is 6 meters. Go to HSL_LNK and follow the appropriate instructions.

This ends the procedure.

HSLH_15

This is a hybrid HSL/RIO to HSL2/RIO-G copper cable.

One end of the cable has an HSL/RIO yellow connector and the other end has an HSL2/RIO-G black connector. The "15" value indicates the length of the cable is 15 meters. Go to HSL_LNK and follow the appropriate instructions.

This ends the procedure.

HSLH_xx

This is a hybrid HSL/RIO to HSL2/RIO-G copper cable.

One end of the cable has an HSL/RIO yellow connector and the other end has an HSL2/RIO-G black connector. The "xx" value indicates the length of the cable in meters. Go to HSL_LNK and follow the appropriate instructions.

This ends the procedure.

I2CBUS

A fault was detected on the I2C bus.

1. Is the reference code of the form 1xxx314x?

- **Yes:** Continue with the next step.
- **No:** Use the following table to determine the FRU to replace. If there are multiple FRUs listed in one row, replace those FRUs one at a time in the order shown.

Reference code	Type and model or feature code	Part number	Description	Location code
3100, 3105	9117-MMA, 9406-MMA, 8234-EMA	10N8752	Primary service processor card	Un-P1-C11
3100, 3104, 3105, 3116, or 3118	5790, 7311-D11	80P6626	I/O backplane	Un-P1
3100, 3104, 3105, 3116, or 3118	0595, 5095, 7311-D20	39J0515	I/O backplane	Un-P1
3100, 3101, 3118, 310A, or 310B	5796, 7314-G30	See Finding parts, locations, and addresses.	1. SPCN card 2. I/O backplane 3. Dual-port 12X Channel Attach adapter	1. Un-P1-C8 2. Un-P1 3. Un-P1-C7
3101, 3115	5790, 7311-D11	1. 22R3958 2. 23R0181	1. Power supply 2. I/O backplane	1. Un-E1 2. Un-P1
3101, 3115	0595, 5095, 7311-D20	1. 53P0330 2. 39J0515 3. 53P0414	1. Control (operator) panel 2. I/O backplane 3. Signal cable that connects the control panel to the I/O backplane	1. Un-NB1 2. Un-P1 3. Un-P1
3102, 3113, 3114	5790, 7311-D11	80P6626	I/O backplane	Un-P1
3102, 3113, 3114	0595, 5095, 7311-D20	39J0515	I/O backplane	Un-P1
3102, 3103, 3104, 3114, 3121, 3122, 2123, 3124	5796, 7314-G30	See Finding parts, locations, and addresses.	1. I/O backplane 2. SPCN card 3. Dual-port 12X Channel Attach adapter	1. Un-P1 2. Un-P1-C8 3. Un-P1-C7
3103, 3112	5790, 7311-D11	80P6626	I/O backplane	Un-P1
3103, 3112	0595, 5095, 7311-D20	1. 39J1695 2. 39J0515	1. Disk drive backplane 2. I/O backplane	1. Un-DBn 2. Un-P1

Reference code	Type and model or feature code	Part number	Description	Location code
3104	0595, 5095, 7311-D20	1. 39J1695 2. 39J0515	1. Disk drive backplane 2. I/O backplane	1. Un-DB1 2. Un-P1
3105, 3125	5796, 7314-G30	See Finding parts, locations, and addresses.	1. Dual-port 12X Channel Attach adapter 2. I/O backplane 3. SPCN card	1. Un-P1-C7 2. Un-P1 3. Un-P1-C8
3106, 3115	5796, 7314-G30	See Finding parts, locations, and addresses.	1. Power supply 2. SPCN card 3. I/O backplane	1. Un-E1 2. Un-P1-C8 3. Un-P1
3114, 3116	8204-E8A, 9509-M50	10N9369	System backplane	Un-P1
3114	9117-MMA, 9406-MMA, 8234-EMA	1. 42R7352 2. 10N8752	1. I/O backplane 2. Primary service processor card	1. Un-P1 2. Un-P1-C11
3116	8203-E4A, 9408-M25	42R7898	System backplane	Un-P1
3121	5790, 7311-D11	1. 03N5633 2. 80P6226	1. RIO/HSL adapter 2. I/O backplane	1. Un-P1-C7 2. Un-P1
3121	0595, 5095, 7311-D20	1. 39J1695 2. 39J0523 3. 39J0515	1. Disk drive backplane 2. RIO/HSL adapter 3. I/O backplane	1. Un-DB1 2. Un-P1-C05 3. Un-P1

This ends the procedure.

2. Is the reference code 1xxx3140?
 - **No:** Continue with the next step.
 - **Yes:** Replace the midplane in the 5802 expansion unit at location Un-P5. **This ends the procedure.**
3. Is the reference code 1xxx3141?
 - **No:** Continue with the next step.
 - **Yes:** If this is your first time here, replace the SAS conduit card in the 5802 expansion unit at location Un-P5. If this is your second time here, replace the midplane in the 5802 expansion unit at location Un-P5. **This ends the procedure.**
4. Is the reference code 1xxx3142?
 - **No:** Continue with the next step.
 - **Yes:** If this is your first time here, replace the DASD backplane in the 5802 expansion unit at location Un-P3. If this is your second time here, replace the SAS conduit card in the 5802 expansion unit at location Un-P4. **This ends the procedure.**
5. Is the reference code 1xxx3143?
 - **No:** Continue with the next step.
 - **Yes:** If this is your first time here, replace the I/O planar in the 5802 expansion unit at location Un-P1. If this is your second time here, replace the midplane in the 5802 expansion unit at location Un-P5. **This ends the procedure.**
6. Is the reference code 1xxx3145?
 - **No:** Continue with the next step.
 - **Yes:** Replace the midplane in the 5802 expansion unit at location Un-P5. **This ends the procedure.**

7. Is the reference code 1xxx3146?
 - **No:** Continue with the next step.
 - **Yes:** Replace the fan in the 5802 expansion unit at location *Un-E1-A1*. If this is your second time here, replace the midplane in the 5802 expansion unit at location *Un-P5*. **This ends the procedure.**
8. Is the reference code 1xxx3147?
 - **No:** Continue with the next step.
 - **Yes:** Replace the fan in the 5802 expansion unit at location *Un-E1-A2*. If this is your second time here, replace the midplane in the 5802 expansion unit at location *Un-P5*. **This ends the procedure.**
9. Is the reference code 1xxx3148?
 - **No:** Continue with the next step.
 - **Yes:** Replace port card 1 in the 5802 expansion unit at location *Un-P3-C1*. If this is your second time here, replace these parts in the 5802 expansion unit in the following order:
 - a. Midplane at location *Un-P5*.
 - b. SAS conduit at location *Un-P4*.
 - c. DASD backplane at location *Un-P3*.**This ends the procedure.**
10. Is the reference code 1xxx3149?
 - **No:** Continue with the next step.
 - **Yes:** Replace port card 2 in the 5802 expansion unit at location *Un-P3-C2*. If this is your second time here, replace these parts in the 5802 expansion unit in the following order:
 - a. Midplane at location *Un-P5*.
 - b. SAS conduit at location *Un-P4*.
 - c. DASD backplane at location *Un-P3*.**This ends the procedure.**
11. Is the reference code 1xxx314A?
 - **No:** Continue with the next step.
 - **Yes:** Replace port card 3 in the 5802 expansion unit at location *Un-P3-C3*. If this is your second time here, replace these parts in the 5802 expansion unit in the following order:
 - a. Midplane at location *Un-P5*.
 - b. SAS conduit at location *Un-P4*.
 - c. DASD backplane at location *Un-P3*.**This ends the procedure.**
12. Is the reference code 1xxx314B?
 - **No:** Continue with the next step.
 - **Yes:** Replace port card 4 in the 5802 expansion unit at location *Un-P3-C4*. If this is your second time here, replace these parts in the 5802 expansion unit in the following order:
 - a. Midplane at location *Un-P5*.
 - b. SAS conduit at location *Un-P4*.
 - c. DASD backplane at location *Un-P3*.**This ends the procedure.**
13. Is the reference code 1xxx3155?
 - **No:** Continue with the next step.
 - **Yes:** If this is your first time here, replace the midplane in the 5802 expansion unit at location *Un-P5*. **This ends the procedure.**
14. Is the reference code 1xxx3156?

- **No:** Continue with the next step.
- **Yes:** If this is your first time here, replace the fan in the 5802 expansion unit at location U_n -E2-A1. If this is your second time here, replace the midplane in the 5802 expansion unit at location U_n -P5. **This ends the procedure.**

15. Is the reference code 1xxx3157?

- **No:** Return to the procedure or symbolic FRU that sent you here.
- **Yes:** If this is your first time here, replace the fan in the 5802 expansion unit at location U_n -E2-A2. If this is your second time here, replace the midplane in the 5802 expansion unit at location U_n -P5. **This ends the procedure.**

IDPART

The configuration ID is incorrect.

Is the reference code 1xxx 840D or 840E?

- **Yes:** Go to PWR1917.
- **No:** The reference code has changed. Return to Starting a service call.

INT_12X

The internal connection between two embedded 12X adapters might be failing.

There is no 12X cable for this 12X internal port. The internal connection location is identified by this FRU in the error log. Replace that FRU if it has not already been replaced.

This ends the procedure.

IO_DEV

A storage device is the failing item.

Perform the following:

1. Is device location information available in the serviceable event view for this FRU?
 - **Yes:** Continue with the next step.
 - **No:** If the adapter controlling this device is listed in the FRU list then use that location code and continue with the next step. Otherwise work with the customer or your next level of support to determine the location of the device or its adapter by using SRC information, failing resource information, device tree or error message information. Then continue with the next step.
2. Use the unit type information in the location code to identify the type of unit where the device or device adapter is located. Then use the following table to exchange the failing item.

Note: The location listed may be a logical path instead of the physical device location. The known device logical location codes are handled in the locations information for each unit type.

FRU name (replace in order, one at a time)	Model, expansion unit, or unit type	Location
Tape drive	8203-E4A	U_n -P2-D1
Disk drive 1	8203-E4A	U_n -P2-D3
Disk drive 2	8203-E4A	U_n -P2-D4
Disk drive 3	8203-E4A	U_n -P2-D5
Disk drive 4	8203-E4A	U_n -P2-D6
Disk drive 5	8203-E4A	U_n -P2-D7
Disk drive 6	8203-E4A	U_n -P2-D8

FRU name (replace in order, one at a time)	Model, expansion unit, or unit type	Location
Tape drive	8204-E8A	Un-P2-D1
Disk drive 1	8204-E8A	Un-P2-D2
Disk drive 2	8204-E8A	Un-P2-D3
Disk drive 3	8204-E8A	Un-P2-D4
Disk drive 4	8204-E8A	Un-P2-D5
Disk drive 5	8204-E8A	Un-P2-D6
Disk drive 6	8204-E8A	Un-P2-D7
Disk drive 1	0595, 5095, 7311-D20	Un-DB1-D01
Disk drive 2	0595, 5095, 7311-D20	Un-DB1-D02
Disk drive 3	0595, 5095, 7311-D20	Un-DB1-D03
Disk drive 4	0595, 5095, 7311-D20	Un-DB1-D04
Disk drive 5	0595, 5095, 7311-D20	Un-DB1-D05
Disk drive 6	0595, 5095, 7311-D20	Un-DB1-D06
Disk drive 7	0595, 5095, 7311-D20	Un-DB2-D07
Disk drive 8	0595, 5095, 7311-D20	Un-DB2-D08
Disk drive 9	0595, 5095, 7311-D20	Un-DB2-D09
Disk drive 10	0595, 5095, 7311-D20	Un-DB2-D10
Disk drive 11	0595, 5095, 7311-D20	Un-DB2-D11
Disk drive 12	0595, 5095, 7311-D20	Un-DB2-D12
Disk drive 1	5094	Un-DB1-D01
Disk drive 2	5094	Un-DB1-D02
Disk drive 3	5094	Un-DB1-D03
Disk drive 4	5094	Un-DB1-D04
Disk drive 5	5094	Un-DB1-D05
Disk drive 6	5094	Un-DB2-D06
Disk drive 7	5094	Un-DB2-D07
Disk drive 8	5094	Un-DB2-D08
Disk drive 9	5094	Un-DB2-D09
Disk drive 10	5094	Un-DB2-D10
Disk drive 11	5094	Un-DB1-D11
Disk drive 12	5094	Un-DB1-D12
Disk drive 13	5094	Un-DB1-D13
Disk drive 14	5094	Un-DB1-D14
Disk drive 15	5094	Un-DB1-D15
Disk drive 16	5094	Un-DB2-D16
Disk drive 17	5094	Un-DB2-D17
Disk drive 18	5094	Un-DB2-D18
Disk drive 19	5094	Un-DB2-D19
Disk drive 20	5094	Un-DB2-D20
Disk drive 21	5094	Un-DB1-D21

FRU name (replace in order, one at a time)	Model, expansion unit, or unit type	Location
Disk drive 22	5094	Un-DB1-D22
Disk drive 23	5094	Un-DB1-D23
Disk drive 24	5094	Un-DB1-D24
Disk drive 25	5094	Un-DB1-D25

CCIN	Description	Model, expansion unit, or unit type	Part number
6607	4 GB disk drive	All	44L0061
6713	9 GB disk drive	All	44L0062
6714	Disk unit and carrier	All	44L0063
6717	Disk unit and carrier	All	97H7332
6718	Disk unit and carrier	All	04N2737
6719	Disk unit and carrier	All	04N4638
	Tape drive, 4 MM 80/160 GB	8203-E4A, 8204-MMA	23R5638
	73 GB disk drive	8203-E4A, 8204-MMA	10N7200 10N7230
	146 GB disk drive	8203-E4A, 8204-MMA	10N7204 10N7232
	300 GB disk drive	8203-E4A, 8204-MMA	10N7208 10N7234
	73.4 GB 15K RPM ultra3 SCSI disk drive/carrier	9406-MMA, 9117-MMA	03N6345 03N5280
	73.4 GB 15K RPM ultra3 SCSI disk drive/carrier	9406-MMA, 9117-MMA	80P3163
	146.8 GB 10K RPM SCSI disk drive/carrier	9406-MMA, 9117-MMA	03N6330
	36.4 GB 15K RPM ultra3 SCSI disk drive/carrier	9406-MMA, 9117-MMA, 7311-D20	03N6340 03N5275
	36.4 GB 15K RPM ultra3 SCSI disk drive/carrier	9406-MMA, 9117-MMA, 7311-D20	80P3159
	73.4 GB 10K RPM 80-pin SCSI disk drive/carrier	9406-MMA, 9117-MMA, 7311-D20	03N5260 03N6325
	18.2 GB 10K RPM SCSI disk drive/carrier Note: The FRU part numbers are interchangeable. Order the FRU part number that matches the FRU part number you are replacing.	9406-MMA, 9117-MMA, 7311-D20	00P3829 00P3064
	36.4 GB 10K RPM SCSI disk drive/carrier	9406-MMA, 9117-MMA	00P3831
	36.4 GB 10K RPM SCSI disk drive/carrier	9406-MMA, 9117-MMA	00P3068

CCIN	Description	Model, expansion unit, or unit type	Part number
	36.4 GB 10K RPM SCSI disk drive/carrier Note: The FRU part numbers are interchangeable. Order the FRU part number that matches the FRU part number you are replacing.	9406-MMA, 9117-MMA, 7311-D20	00P3831 00P3068
	70 GB disk drive	9406-MMA, 9117-MMA	97P2991
	146 GB disk drive	9406-MMA, 9117-MMA, 7031-D24, 7031-T24	03N5285
	146.8 GB 15K RPM Ultra320 SCSI disk drive	9406-MMA, 9117-MMA, 7311-D20, 7031-D24, 7031-T24	03N6350
	146.8 GB 10,000 RPM Ultra320 SCSI disk drive	9406-MMA, 9117-MMA, 7311-D20, 7031-T24, 7031-T24	03N5265
	300 GB disk drive, SCSI	9406-MMA, 9117-MMA, 7311-D20	03N5270
	300 GB 10K RPM Ultra320 SCSI disk drive, 1 inch	9406-MMA, 9117-MMA, 7311-D20, 7031-D24, 7031-T24	03N6335
	300 GB 10K RPM Ultra320 SCSI disk drive/carrier	9406-MMA, 9117-MMA, 7311-D20, 7031-D24, 7031-T24	03N5270

IO HUB

The failing component is the RIO/HSL hub on the IPL path.

Use the following table to determine the part number for the field replaceable unit (FRU):

Type and model	Part number	Description	Location code
8204-E8A	10N9369	System backplane	Un-P1
9406-MMA, 9117-MMA	42R7352	I/O backplane (Primary unit)	Un-P1
9406-MMA, 9117-MMA	42R7352	I/O backplane (Secondary units)	Un-P1

IOA

The I/O adapter might be failing.

Go to FI00719 to determine the field replaceable unit (FRU) part number.

This ends the procedure.

IOACNFG

There is an IOA configuration problem.

Too many communications lines or IOAs are configured using the same IOP.

IOADPTR

The failing component is the adapter in the location specified in the SRC.

1. Are you working from the serviceable event view and is there a card location listed with this FRU?
 - **Yes:** Use Table 1 to replace the adapter identified by this location code. **This ends the procedure.**
 - **No:** Determine the location of the adapter by working with the customer or your next level of support. If you cannot determine the location of the failing adapter by using SRC or resource information or the device tree, then determine the adapter type from the SRC, SRC description, failing resources, or error message you are working with. Make a list of all the adapter locations of that type assigned to the partition. Continue with the next step.

2. Have you identified a single FRU location?

- **Yes:** Use Table 1 to replace the FRU you have identified. **This ends the procedure.**
- **No:** Continue with the next step.

3. Using the location codes you have identified, determine which system unit and expansion units have PCI adapters of this type assigned to the partition you are working with. Starting with the expansion units first, remove all of the PCI adapters of this type from one of the units (use Table 1 to guide you to the correct locations information).

Attention:

- Remove the PCI adapters from the system unit only after you have tried all of the expansion units first.
- Do **not** remove any FRUs with embedded adapters, only FRUs in PCI card slots.

Continue with the next step.

4. Reinstall one of the adapters and power on the unit. Continue with the next step.

5. Does the problem reoccur?

- **Yes:** The adapter you just reinstalled is the failing item and needs to be replaced (use Table 1 to guide you to the correct locations information). **This ends the procedure.**
- **No:** Continue with the next step.

6. Have you reinstalled all of the adapters on the unit you're currently working with?

- **Yes:** Continue with the next step.
- **No:** Return to step 4 and reinstall the next adapter on this unit.

7. Are there any units (including the system unit) on which you have not yet removed and reinstalled the PCI adapters?

- **No:** Continue with the next step.
- **Yes:** Return to step 3 and work with another unit.

8. Go to "Card Positions" in the service guide for the unit on which you are working to determine if system unit or any of the expansion units has an embedded adapter of the type you are working with. Is there such an embedded adapter?

- **No:** The problem might be intermittent. Contact your next level of support. **This ends the procedure.**
- **Yes:** The FRU with the embedded adapter is the failing item and needs to be replaced. Use Table 1 to exchange the FRU at the location specified in the card position table. Repeat this step for each expansion unit with an embedded adapter assigned to the partition, and then for the system unit. **This ends the procedure.**

Table 9. Failing items for symbolic FRU IOADPTR

FRU name (replace in order, one at a time)	Model, expansion unit, or unit type	Location
For each unit, starting with the primary unit and then the secondary units (if applicable):		

Table 9. Failing items for symbolic FRU IOADPTR (continued)

FRU name (replace in order, one at a time)	Model, expansion unit, or unit type	Location
PCI adapter in slot 1	5094	Un-CB1-C01
PCI adapter in slot 2	5094	Un-CB1-C02
PCI adapter in slot 3	5094	Un-CB1-C03
PCI adapter in slot 4	5094	Un-CB1-C04
PCI adapter in slot 5	5094	Un-CB1-C05
PCI adapter in slot 6	5094	Un-CB1-C06
PCI adapter in slot 7	5094	Un-CB1-C07
PCI adapter in slot 8	5094	Un-CB1-C08
PCI adapter in slot 9	5094	Un-CB1-C09
RIO/HSL adapter card	5094	Un-CB1-C10
PCI adapter in slot 11	5094	Un-CB1-C11
PCI adapter in slot 12	5094	Un-CB1-C12
PCI adapter in slot 13	5094	Un-CB1-C13
PCI adapter in slot 14	5094	Un-CB1-C14
PCI adapter in slot 15	5094	Un-CB1-C15
PCI adapter in slot 1	0595, 5095	Un-CB1-C01
PCI adapter in slot 2	0595, 5095	Un-CB1-C02
PCI adapter in slot 3	0595, 5095	Un-CB1-C03
PCI adapter in slot 4	0595, 5095	Un-CB1-C04
RIO/HSL adapter card	0595, 5095	Un-CB1-C05
PCI adapter in slot 6	0595, 5095	Un-CB1-C06
PCI adapter in slot 7	0595, 5095	Un-CB1-C07
PCI adapter in slot 8	0595, 5095	Un-CB1-C08
PCI adapter in slot 1	8204-E4A, 8204-E8A	Un-P1-C1
PCI adapter in slot 2	8204-E4A, 8204-E8A	Un-P1-C2
PCI adapter in slot 3	8204-E4A, 8204-E8A	Un-P1-C3
PCI adapter in slot 4	8204-E4A, 8204-E8A	Un-P1-C4
PCI adapter in slot 5	8204-E4A, 8204-E8A	Un-P1-C5
System backplane	8204-E4A, 8204-E8A	Un-P1
PCI adapter in slot 1	9406-MMA, 9117-MMA	Un-P1-C1
PCI adapter in slot 2	9406-MMA, 9117-MMA	Un-P1-C2
PCI adapter in slot 3	9406-MMA, 9117-MMA	Un-P1-C3
PCI adapter in slot 4	9406-MMA, 9117-MMA	Un-P1-C4
PCI adapter in slot 5	9406-MMA, 9117-MMA	Un-P1-C5
PCI adapter in slot 6	9406-MMA, 9117-MMA	Un-P1-C6
I/O backplane	9406-MMA, 9117-MMA	Un-P1
PCI adapter in slot 1	7311-D11, 7314-G30	Un-P1-C1
PCI adapter in slot 2	7311-D11, 7314-G30	Un-P1-C2
PCI adapter in slot 3	7311-D11, 7314-G30	Un-P1-C3

Table 9. Failing items for symbolic FRU IOADPTR (continued)

FRU name (replace in order, one at a time)	Model, expansion unit, or unit type	Location
PCI adapter in slot 4	7311-D11, 7314-G30	Un-P1-C4
PCI adapter in slot 5	7311-D11, 7314-G30	Un-P1-C5
PCI adapter in slot 6	7311-D11, 7314-G30	Un-P1-C6
I/O backplane	7311-D11, 7314-G30	Un-P1
PCI adapter in slot 1	0595, 5095, 7311-D20	Un-P1-C01
PCI adapter in slot 2	0595, 5095, 7311-D20	Un-P1-C02
PCI adapter in slot 3	0595, 5095, 7311-D20	Un-P1-C03
PCI adapter in slot 4	0595, 5095, 7311-D20	Un-P1-C04
PCI adapter in slot 6	0595, 5095, 7311-D20	Un-P1-C06
PCI adapter in slot 7	0595, 5095, 7311-D20	Un-P1-C07
PCI adapter in slot 8	0595, 5095, 7311-D20	Un-P1-C08
I/O backplane	0595, 5095, 7311-D20	Un-P1

For PCI adapter FRU part numbers, go to Managing PCI adapters. See the following table for embedded controller FRUs:

CCIN or FFC	Type and model	Part number	Description	Location code
	8203-E4A	42R7898	System backplane	Un-P1
	8204-E8A	10N9369	System backplane	Un-P1
	9406-MMA, 9117-MMA	42R7352	I/O backplane	Un-P1
	5790, 7311-D11	80P6626	I/O backplane	Un-P1
	0595, 5095, 7311-D20	39J0515	I/O backplane	Un-P1
	5796, 7314-G30	See Finding parts, locations, and addresses.	I/O backplane	Un-P1

IOBRDG

The failing component is the RIO/HSL I/O bridge on the IPL path.

Use the following table to determine the part number for the field replaceable unit (FRU):

CCIN or FFC	Type and model	Part number	Description	Location code
	8203-E4A	42R7898	System backplane	Un-P1
	8204-E8A	10N9369	System backplane	Un-P1
	9406-MMA, 9117-MMA	42R7352	For each unit, starting with the primary unit and then the secondary units, replace the I/O backplane	Un-P1

This ends the procedure.

IOP

Replace the I/O processor.

Use the I/O processor location information in the service action log if it is available. If the location is not available, find the address of the I/O processor. See Determining system reference code address formats. Use the address to find the location. See the table below.

FRU name	Model, expansion unit, or unit type	Location
IOP	9406-MMA	Un-P1-C1
possible IOP	9406-MMA	Un-P1-C2
IOP	9406-MMA	Un-P1-C3
possible IOP	9406-MMA	Un-P1-C4, Un-P1-C5, Un-P1-C6
IOP or IXS	5094	Un-CB1-C01
possible IOP	5094	Un-CB1-C02, Un-CB1-C03, Un-CB1-C04
IOP or IXS	5094	Un-CB1-C05
possible IOP	5094	Un-CB1-C06, Un-CB1-C07, Un-CB1-C08, Un-CB1-C09
IOP or IXS	5094	Un-CB1-C11
possible IOP	5094	Un-CB1-C12, Un-CB1-C13, Un-CB1-C14, Un-CB1-C15
IOP or IXS	0595, 5095	Un-CB1-C01
possible IOP	0595, 5095	Un-CB1-C02, Un-CB1-C03, Un-CB1-C04
IOP or IXS	0595, 5095	Un-CB1-C06
possible IOP	0595, 5095	Un-CB1-C07, Un-CB1-C08
IOP	0595, 5095, 7311-D20	Un-P1-C01
possible IOP	0595, 5095, 7311-D20	Un-P1-C02, Un-P1-C03, Un-P1-C04
IOP	0595, 5095, 7311-D20	Un-P1-C06
possible IOP	0595, 5095, 7311-D20	Un-P1-C07, Un-P1-C08

LBSADP1

This symbolic FRU is not supported on the system.

Continue with the next FRU in the failing item list.

LBSADP2

This symbolic FRU is not supported on the system.

Continue with the next FRU in the failing item list.

LBSADP3

This symbolic FRU is not supported on the system.

Continue with the next FRU in the failing item list.

LBSADP4

This symbolic FRU is not supported on the system.

Continue with the next FRU in the failing item list.

LBSADP5

This symbolic FRU is not supported on the system.

Continue with the next FRU in the failing item list.

LBUSADP

This symbolic FRU is not supported on the system.

Continue with the next FRU in the failing item list.

LIB3494

The 3494 tape library might be failing.

Refer to the IBM 3494 maintenance information to determine the part(s) to replace.

LICCODE

This symbolic FRU helps determine the preferred method of updating server firmware or Licensed Internal Code.

Note: In this procedure, server firmware is synonymous with Licensed Internal Code.

1. Check the level of the firmware on which the server is running. For information about checking firmware levels, see "Viewing existing firmware (Licensed Internal Code) levels" in the operations guide or service guide that applies to your server.

Note: For information on the latest available firmware levels, refer to Fix Central at <http://www.ibm.com/eserver/support/fixes/>.

Is the server firmware at the latest available level?

- **No:** Continue with the next step.
 - **Yes: This ends the procedure.**
2. Is this the first time you are trying to update the server firmware while working on this problem?
 - **No:** Choose from the following options:
 - If you are a customer, contact your next level of support.
 - If you are a service provider, use a USB flash drive to update the server firmware. Refer to "Using a USB flash drive to update the server firmware" in the service guide for the server. If a USB flash drive is not available, go to symbolic FRU SVCPROC to update the server firmware by replacing the service processor. **This ends the procedure.**
 - **Yes:** Continue with the next step.
 3. Is the system managed by an HMC?
 - **No:** Go to step 5.
 - **Yes:** Continue with the next step.
 4. Refer to one of the following procedures in the service guide for the system unit:
 - "Obtaining server and power subsystem firmware fixes through an HMC with an Internet connection."
 - "Obtaining server firmware and power subsystem firmware fixes through an HMC using a CD-ROM, FTP server, or hard drive."

- "Obtaining server firmware fixes through the IBM i operating system."

Note: The procedure, "Obtaining server firmware fixes through the IBM i operating system" can only be used if the server is a System i with no 24-inch rack bulk power.

This ends the procedure

5. Is the operating system running or is Integrated Virtualization Manager (IVM) available?
 - **No:** Continue with the next step.
 - **Yes:** Go to step 8.
6. Attempt to IPL the system from the side of the service processor from which you are currently booting, and start the operating system or IVM.

Note: For information about how to see from which side of the service processor you are booting, and to find out how to switch to the other side if necessary, see "Working with the temporary and permanent side of the service processor" in the service guide for the server.

Were you successful?

- **No:** Continue with the next step.
 - **Yes:** Go to step 8.
7. Attempt to boot the system from the other side of the service processor, and start the operating system or IVM. Were you successful?
 - **No:** Choose from the following:
 - If you are a customer, contact your next level of support.
 - If you are a service provider, use a USB flash drive to update the server firmware. Refer to "Using a USB flash drive to update the server firmware on a unit that is not responding" in the service guide for the server. If a USB flash drive is not available, go to symbolic FRU SVCPROC to update the server firmware by replacing the service processor. **This ends the procedure.**
 - **Yes:** Go to step 8.
 8. Use the following table to determine the action to take:

Type of partition on which you are working	Action
Integrated Virtualization Manager (IVM) managed system	Update the server firmware using procedures found in the system service guide. Refer to "Getting fixes for the Virtual I/O Server."
AIX	Update the server firmware using procedures found in the system service guide. Refer to "Getting server firmware fixes through AIX or Linux without an HMC."
IBM i operating system	Update the server firmware using procedures found in the system service guide. Refer to "Getting server firmware fixes through the IBM i operating system."
Linux	Update the server firmware using procedures found in the system service guide. Refer to "Getting server firmware fixes through AIX or Linux without an HMC."

If you are still unable to update the server firmware, contact your next level of support.

Attention: Be aware that a newer level of server firmware might already have been downloaded before this problem occurred or when the problem was reported.

This ends the procedure.

LITSTRP

Look here for information about LITSTRP symbolic FRU.

Use the following table to perform the appropriate action for the SRC you are working with.

SRC	Replace this FRU	Link to locations information
1xxx1D04	Light strip (front)	Part locations and location codes
1xxx1D05	Light strip (back)	

LOADCY1

A cryptographic adapter Licensed Internal Code problem occurred.

The Licensed Internal Code for the cryptographic adapter does not ship with the system. The licensed program 5733-CY1 Cryptographic Device Manager contains the Licensed Internal Code for the cryptographic adapter.

- If the SRC is B0136615, do the following:
 1. Vary off the cryptographic adapter.
 2. Apply the licensed program to the system.
 3. Vary on the cryptographic adapter.

Note: The vary on might take up to 15 minutes.

This ends the procedure

- If the SRC is B0136619, do the following:
 1. Vary off the cryptographic adapter.
 2. Apply the most recent version of the licensed program to the system.
 3. Vary on the cryptographic adapter.

Note: The vary on might take up to 15 minutes.

This ends the procedure

LOC_SYS

A problem has occurred on the local (this) system with IBM i HSL OptiConnect.

The IBM i service action log (SAL) code will attempt to identify the HSL/RIO loop number as a portion of the FRU's part description for this symbolic FRU. Search the SAL of this system for hardware and Licensed Internal Code problems. Correct any problems that you find with License Internal Code or Network Interface Controller (NIC) / RIO controller hardware.

This ends the procedure.

LPARCFG

There is a configuration problem with the system or a logical partition.

Perform any actions listed in the "Description/Action" column in the unit reference code table for the reference code.

Have the customer check processor and memory allocations of the system or to the partition. The customer must ensure that there are enough functioning processor and memory resources in the system for all the partitions. Processor or memory resources that failed during system IPL could have caused the IPL problem in the partition.

Have the customer check the bus and I/O processor allocations for the partition. The customer must ensure that the partition has load source and console I/O resources.

Have the customer check the IPL mode of the system or failing partition.

For further assistance, the customer should contact their software service provider, or see Logical partitioning for additional support.

This ends the procedure.

LPARSUP

There is either an IPL problem, a main storage dump problem, or a software error with a partition.

Perform any actions listed in the "Description/Action" column in the SRC table.

During the IPL or main storage dump of a partition, a complex problem was detected. The serviceable event view on the HMC has to be searched or the SRC history list on the HMC for the partition with the problem has to be analyzed in sequence. If the partition is a "Guest" partition, then the SRC history list of the "Hosting" partition must be analyzed.

Contact your next level of hardware support.

LSERROR

An error occurred when the platform Licensed Internal Code attempted to locate the IBM i partition's load source.

Choose from the following:

- If the load source is a tape or optical device, exchange the media. If replacing the media does not work, look in the serviceable event view for other errors.
- If the load source is a disk drive, perform a D-mode IPL. Correct any errors found.

This ends the procedure.

MA_BRDG

The problem is the multi-adapter bridge hardware on a system bus.

Perform the following:

1. Is the location information for this failing component available in the problem view you are working with of the serviceable event user interface of an operating system, service processor, or Hardware Management Console (HMC)?
 - **No:** Record the bus number value, BBBB, in word 7 of the reference code and continue with the next step.
 - **Yes:** Use this location information and continue with the next step.
2. The failing component is the FRU containing the multi-adapter bridge. Use the following table to identify the name of the FRU that is indicated by the location in the user interface you are working with, or by using the bus number you obtained previously in this procedure to exchange the FRU.

CCIN or FFC	Type and model	Part number	Description	Location code
	8203-E4A	42R7898	System backplane	Un-P1
	8204-E8A	10N9369	System backplane	Un-P1
	9406-MMA, 9117-MMA	42R7352	I/O backplane	Un-P1
	5790, 7311-D11	80P6626	I/O backplane	Un-P1
	0595, 5095, 7311-D20	39J0515	I/O backplane	Un-P1

CCIN or FFC	Type and model	Part number	Description	Location code
	5796, 7314-G30	See Finding parts, locations, and addresses.	I/O backplane	Un-P1
	5094	39J3058	I/O backplane	Un-CB1

This ends procedure.

MABRCFG

The multi-adapter bridge hardware detected a configuration problem.

In some cases, the user interface view of the serviceable event will list more than one card position for this FRU's location. The problem might be with any one of the FRUs in those locations. When there is a list of locations in this FRU's location code, the card locations will be separated by commas. A range of card positions will show the starting card position, a colon, and the ending card position.

- Are you working from the service event user interface from an operating system, service processor, or the HMC and there is a card position(s) listed with this failing item?
 - Yes:** The listed card position(s) is where the error is located. Continue with the next step.
 - No:** Go to MABIP53 to determine the card location where the multi-adapter bridge configuration error exists. Return here after locating the card, and continue with the next step.
- Use the following table to determine the corrective action.

Table 10. Multi-adapter bridge errors

Problem or message (these appear in uppercase in the console)	Meaning or corrective action
Multi-adapter bridge has no IOP for the I/O adapters.	<ol style="list-style-type: none"> System code detected one or more I/O adapters under the multi-adapter bridge specified in the DSA, but no I/O processor to control them. The I/O adapters are not available to the system. The problem view lists the card locations controlled by the multi-adapter bridge. If you do not have the card locations listed in the problem view, find them by continuing with the next step. Otherwise, go to step 3. To locate the I/O adapters, search for the card locations controlled by the multi-adapter bridge. The multi-adapter bridge number is in the DSA (go to DSA translation. To determine all the card locations controlled by the multi-adapter bridge, see Card positions. To make the I/O adapters available to the system, install an I/O processor in a card slot controlled by the multi-adapter bridge or move the I/O adapters to a multi-adapter bridge with an I/O processor. When adding an IOP, place it in a card position that is ahead of the IOAs according to the "IOA Assignment Rules" table located in the Part locations and location codes.

Table 10. Multi-adapter bridge errors (continued)

Problem or message (these appear in uppercase in the console)	Meaning or corrective action
Card type not supported in this slot.	<p>System code detected a card type that is not supported in the multi-adapter bridge card location in which it is installed. Move the card to a location that will support that card type (check the installation instructions for the card to determine which card locations can support it).</p> <p>For reference codes where word 1 is B6006964 and word 4 is xxxx2015, if the SAL does not show a card position for this error, then the card position can be determined by creating a Direct Select Address (DSA) from information in the reference code. To create the DSA, use the first 5 digits of word 7 and the 6th digit of word 5 followed by two zeros. Using this DSA, go to MABIP53 to determine the position of the card that is not supported in that slot.</p>
I/O processor removed from multi-adapter bridge card slot.	System code detected that an I/O processor card was located in that card location on the previous IPL. The I/O processor is no longer installed in that location.
I/O adapter unavailable due to moved I/O processor card.	System code detected that the I/O processor which controlled the I/O adapter card specified in the DSA has been moved since the last IPL. The I/O adapter card is unavailable to the system.
IOA removed from multi-adapter bridge slot.	System code detected that the card location specified in the DSA had an I/O adapter installed on the previous IPL. The I/O adapter is no longer installed in that card location.
I/O adapter replaced by I/O processor card.	System code detected that the card location specified in the DSA had an I/O adapter installed on the previous IPL. The I/O adapter has been replaced by an I/O processor.
Multi-adapter bridge configuration change or error.	System code has detected a change in the multi-adapter bridge configuration or a configuration error since the last IPL.

Table 10. Multi-adapter bridge errors (continued)

Problem or message (these appear in uppercase in the console)	Meaning or corrective action
<p>PCI I/O processor rejected assignment or removal of an IOA.</p>	<p>The I/O processor's (IOP) Licensed Internal Code has rejected the assignment of an I/O adapter (IOA) to that IOP, or the IOP's Licensed Internal Code has rejected the removal of an IOA that the IOP owns.</p> <p>Word 5 of the reference code is the Direct Select Address (DSA) of the IOP. Word 7 of is the DSA of the IOA. To find the IOP and IOA, go to MABIP53 using the DSA.</p> <p>Use Hardware Service Manager (HSM) concurrent maintenance functions to assign or remove the IOA.</p> <p>Assignment failures can result from either of the following conditions:</p> <ul style="list-style-type: none"> • The IOP is already at its capacity to accept IOA assignments. • The IOA is not a type supported by the IOP. <p>Corrective action:</p> <ul style="list-style-type: none"> • Add another IOP for Licensed Internal Code to assign the IOA to if necessary. • Reassign the IOA to another IOP using concurrent maintenance. <p>Removal failures:</p> <ul style="list-style-type: none"> • This is a Licensed Internal Code problem and should be reported. • Call your next level of support.
<p>The partition that owns the card position does not support IOPs.</p>	<p>An IOP card was found in a PCI bridge set that is allocated to a partition that does not support IOPs. The IOP will not be supported in this card position.</p>

This ends the procedure.

MAILBOX

Connection monitoring errors have been detected, indicating mailbox failures.

1. Are there any B1xxxxxx or B7xxxxxx SRCs from the system?
 - **No:** Continue with the next step.
 - **Yes:** Follow the service action for the first SRC that is listed. **This ends the procedure.**
2. There might be firmware fixes for this problem. Load and apply any platform firmware fixes or new levels of firmware using symbolic FRU LICCODE. Does the problem persist after updating the firmware?
 - **No: This ends the procedure.**
 - **Yes:** Continue to the next FRU in the list. **This ends the procedure.**

MASBUS

The multi-adapter bridge detected a problem with a connection to a PCI adapter that it controls either in a physical card location or embedded in a FRU.

The problem is either in the bus between the multi-adapter bridge and the adapter, or with the card slot. The card location might or might not have an installed card.

1. Are you working from the serviceable event view and a card location is listed with this FRU?
 - **No:** Record the bus number value, BBBB, in word 7 of the reference code. Word 7 of the reference code allows you to determine the correct bus number, bus type, multi-adapter bridge number, multi-adapter bridge function number, and logical card number from the Direct Select Address (DSA), see DSA translation. Continue with the next step.
 - **Yes:** Then the listed card location is where the error is located. Continue with the next step.
2. The failing component is the FRU containing the physical or embedded card slot that is controlled by the multi-adapter bridge. Identify the system model, I/O unit, or machine type that is indicated by the location in the serviceable event view, or by using the bus number.

Use the following table to determine the part number for the field replaceable unit (FRU):

Table 11. Failing component service information for MASBUS

CCIN or FFC	Type and model	Part number	Description	Location code
	8203-E4A	42R7898	System backplane	Un-P1
	8204-E8A	10N9369	System backplane	Un-P1
	9406-MMA, 9117-MMA	42R7352	I/O backplane	Un-P1
	5790, 7311-D11	80P6626	I/O backplane	Un-P1
	0595, 5095, 7311-D20	39J0515	I/O backplane	Un-P1
	5796, 7314-G30	See Finding parts, locations, and addresses.	I/O backplane	Un-P1
	5094, 5096, 5294, 5296	39J3058	I/O backplane	Un-CB1

This ends the procedure.

MEDIA

The drive or media might be dirty, or the media might be defective.

1. Is the drive in a 3995 or 3996 optical library?
 - **Yes:** Try a different media. **This ends the procedure.**
 - **No:** Continue with the next step.
2. If the drive is a 6330 DVD-RAM, clean the drive. The part number for the DVD cleaning kit is 19P0489.
3. If it is a tape media, clean the recording head in the tape unit.
4. Attempt the failing operation again. Does the operation complete successfully?
 - **No:** Replace the media. **This ends the procedure.**
 - **Yes:** The problem has been corrected. **This ends the procedure.**

MEMBRD

The failing component is the board the memory DIMMs plug into.

Use the following table to determine which FRU to replace.

Note: To simplify this information, secondary units on the MMA server are numbered 1 through 3. Secondary unit 1 is nearest to the primary unit. Secondary unit 3 is farthest away from the primary unit.

Use the following table to determine the part number for the field replaceable unit (FRU):

CCIN or FFC	Type and model	Part number	Description	Location code
	8203-E4A	42R7898	System backplane	Un-P1
53E1	8204-E8A	10N9377	GHz 4.2 GHz POWER6, 2 Core Processor Card (FC4966)	Un-P1-C x
53E2	8204-E8A	10N9380	GHz 4.7 GHz POWER6, 2 Core Processor Card (FC4967)	Un-P1-C x
	9406-MMA, 9117-MMA	10N9146	3.5 GHz POWER6, 2 Core Processor Card	Un-P2-C x
	9406-MMA, 9117-MMA	10N9144	4.2 GHz POWER6, 2 Core Processor Card	Un-P2-C x
	9406-MMA, 9117-MMA	10N9139	4.7 GHz POWER6, 2 Core Processor Card	Un-P2-C x

MEMCTLR

The failing component is one of the memory controllers.

For each unit, starting with the primary unit and then the secondary units, use the following table to determine the part number for the field replaceable unit (FRU):

CCIN or FFC	Type and model	Part number	Description	Location code
	8203-E4A	42R7898	System backplane	Un-P1
53E1	8204-E8A	10N9377	4.2 GHz POWER6, 2 Core Processor Card (FC4966)	Un-P1-Cx
53E2	8204-E8A	10N9380	4.7 GHz POWER6, 2 Core Processor Card (FC4967)	Un-P1-Cx
	9406-MMA, 9117-MMA	10N9146	3.5 GHz POWER6, 2 Core Processor Card	Un-P1-Cx
	9406-MMA, 9117-MMA	10N9144	4.2 GHz POWER6, 2 Core Processor Card	Un-P1-Cx
	9406-MMA, 9117-MMA	10N9139	4.7 GHz POWER6, 2 Core Processor Card	Un-P1-Cx

This ends the procedure.

MEMDIMM

The failing component is one of the memory DIMMs.

Use the following table to determine which FRU to replace. The locations information will give the location code for the memory module. Replace the memory DIMM for each processor card (starting with processor card 1) on each unit (on multiple-drawer servers, start with the primary unit and then the secondary units):

Table 12. 8203-E4A

FRU name (replace in order, one at a time)	Location
Memory module 1	Un-P1-C14
Memory module 2	Un-P1-C15
Memory module 3	Un-P1-C16
Memory module 4	Un-P1-C17
Memory module 5	Un-P1-C21
Memory module 6	Un-P1-C22
Memory module 7	Un-P1-C23
Memory module 8	Un-P1-C24

Table 13. 8204-E8A

FRU name (replace in order, one at a time)	Location
Memory module 1 on processor card 1	Un-P1-C13-C1
Memory module 2 on processor card 1	Un-P1-C13-C2
Memory module 3 on processor card 1	Un-P1-C13-C3
Memory module 4 on processor card 1	Un-P1-C13-C4
Memory module 5 on processor card 1	Un-P1-C13-C6
Memory module 6 on processor card 1	Un-P1-C13-C7
Memory module 7 on processor card 1	Un-P1-C13-C8
Memory module 8 on processor card 1	Un-P1-C13-C9
Memory module 1 on processor card 2	Un-P1-C14-C1
Memory module 2 on processor card 2	Un-P1-C14-C2
Memory module 3 on processor card 2	Un-P1-C14-C3
Memory module 4 on processor card 2	Un-P1-C14-C4
Memory module 5 on processor card 2	Un-P1-C14-C6
Memory module 6 on processor card 2	Un-P1-C14-C7
Memory module 7 on processor card 2	Un-P1-C14-C8
Memory module 8 on processor card 2	Un-P1-C14-C9
Memory module 1 on processor card 3	Un-P1-C15-C1
Memory module 2 on processor card 3	Un-P1-C15-C2
Memory module 3 on processor card 3	Un-P1-C15-C3
Memory module 4 on processor card 3	Un-P1-C15-C4
Memory module 5 on processor card 3	Un-P1-C15-C6
Memory module 6 on processor card 3	Un-P1-C15-C7
Memory module 7 on processor card 3	Un-P1-C15-C8
Memory module 8 on processor card 3	Un-P1-C15-C9
Memory module 1 on processor card 4	Un-P1-C16-C1
Memory module 2 on processor card 4	Un-P1-C16-C2
Memory module 3 on processor card 4	Un-P1-C16-C3
Memory module 4 on processor card 4	Un-P1-C16-C4
Memory module 5 on processor card 4	Un-P1-C16-C6

Table 13. 8204-E8A (continued)

FRU name (replace in order, one at a time)	Location
Memory module 6 on processor card 4	Un-P1-C16-C7
Memory module 7 on processor card 4	Un-P1-C16-C8
Memory module 8 on processor card 4	Un-P1-C16-C9

Table 14. 9406-MMA or 9117-MMA Primary and secondary units

FRU name (replace in order, one at a time)	Location
Memory module 1	Un-P2-C1-C1
Memory module 2	Un-P2-C1-C2
Memory module 3	Un-P2-C1-C3
Memory module 4	Un-P2-C1-C4
Memory module 5	Un-P2-C1-C5
Memory module 6	Un-P2-C1-C6
Memory module 7	Un-P2-C1-C7
Memory module 8	Un-P2-C1-C8
Memory module 9	Un-P2-C1-C9
Memory module 10	Un-P2-C1-C10
Memory module 11	Un-P2-C1-C11
Memory module 12	Un-P2-C1-C12
Memory module 1	Un-P2-C2-C1
Memory module 2	Un-P2-C2-C2
Memory module 3	Un-P2-C2-C3
Memory module 4	Un-P2-C2-C4
Memory module 5	Un-P2-C2-C5
Memory module 6	Un-P2-C2-C6
Memory module 7	Un-P2-C2-C7
Memory module 8	Un-P2-C2-C8
Memory module 9	Un-P2-C2-C9
Memory module 10	Un-P2-C2-C10
Memory module 11	Un-P2-C2-C11
Memory module 12	Un-P2-C2-C12

Use the following table to determine the part number for the field replaceable unit (FRU):

Table 15. Part Number table

CCIN or FFC	Type and model	Part number	Description	Location code
4520	8203-E4A, 8204-E8A	77P6497	512 GB DDR2 memory DIMM	Un-P1-Cx-Cx
4521	8203-E4A, 8204-E8A	77P6498	1 GB DDR2 memory DIMM	Un-P1-Cx-Cx
4522	8203-E4A, 8204-E8A	77P6499	2 GB DDR2 memory DIMM	Un-P1-Cx-Cx

Table 15. Part Number table (continued)

CCIN or FFC	Type and model	Part number	Description	Location code
4523	8203-E4A, 8204-E8A	77P6500	4 GB DDR2 memory DIMM	Un-P1-Cx-Cx
2947	8203-E4A, 8204-E8A	87H3621	8 GB DDR1 memory DIMM	Un-P1-Cx-Cx
4524	8203-E4A, 8204-E8A	77P7504	16 GB DDR2 memory DIMM	Un-P1-Cx-Cx
	9406-MMA, 9117-MMA	15R7433	512 MB DDR2 memory DIMM	Un-P2-Cx
	9406-MMA, 9117-MMA	15R7436	1 GB DDR2 memory DIMM	Un-P2-Cx
	9406-MMA, 9117-MMA	15R7439	2 GB DDR2 memory DIMM	Un-P2-Cx
	9406-MMA, 9117-MMA	15R7445	4 GB DDR1 memory DIMM	Un-P2-Cx
	9406-MMA, 9117-MMA	15R7448	8 GB DDR2 memory DIMM	Un-P2-Cx

This ends the procedure.

MEMORY

Use this topic to view memory and location information for the 2890 and 2892 Integrated xSeries Server (IXS) cards.

Memory for 2890 Integrated xSeries Server (IXS) card

Figure 1. Locations of DIMM 0, DIMM 1, DIMM 2 and DIMM 3 on 2890 Integrated xSeries Server (IXS) card.

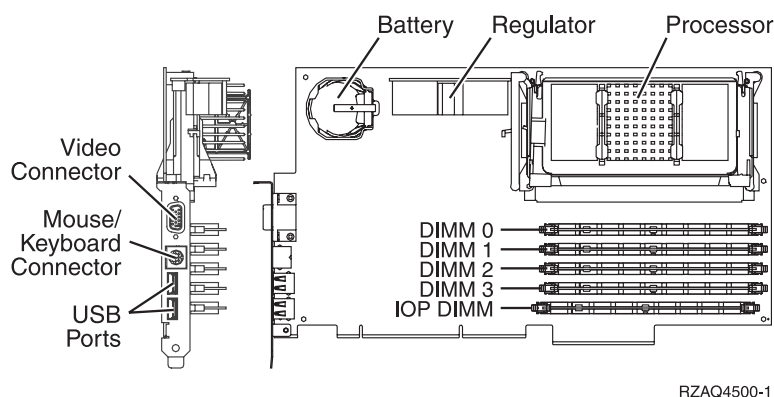

One of the Pentium® memory modules (DIMM 0, DIMM 1, DIMM 2, or DIMM 3) may be the failing item (see Finding parts, locations, and addresses).

Feature	Size
2795/2895	128 MB
2796/2896	256 MB
2797/2897	1 GB

Notes:

1. At least 1 Pentium memory module is required in positions DIMM 0, DIMM 1, DIMM 2 or DIMM 3.
2. An IXS adapter card IOP (see Finding parts, locations, and addresses) is required in the IOP DIMM position. This IOP memory module is NOT interchangeable with the Pentium memory module(s) in positions DIMM 0, DIMM 1, DIMM 2 or DIMM 3.

Memory for 2892 Integrated xSeries Server (IXS) card

Figure 2. Locations of DIMM 0, DIMM 1, DIMM 2 and DIMM 3 on 2892 Integrated xSeries Server (IXS) card

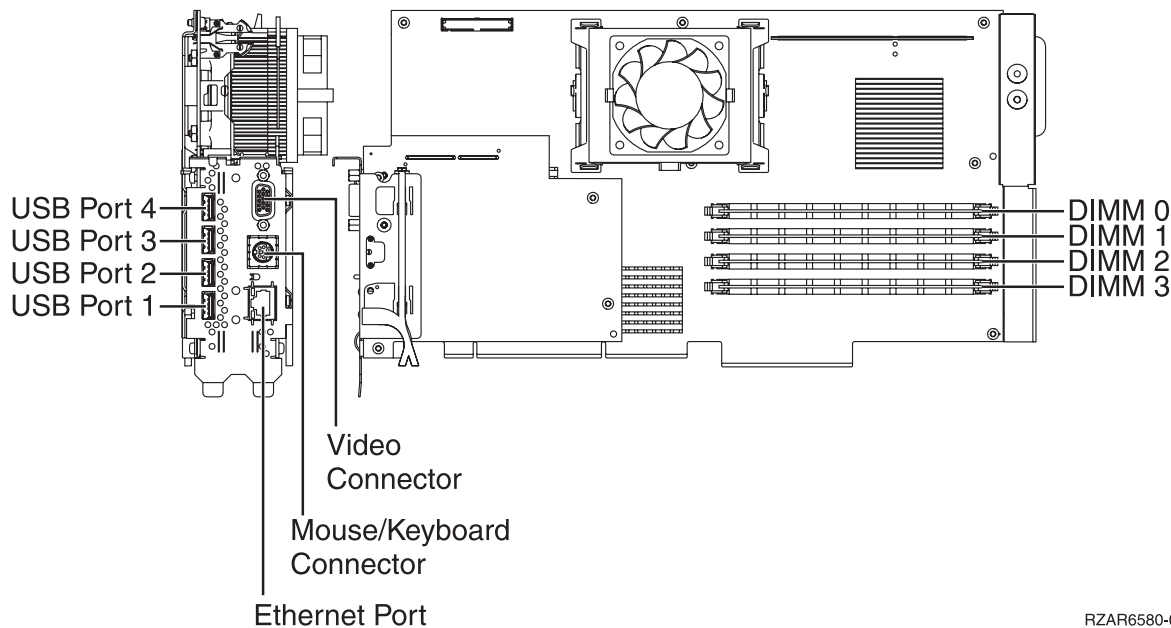

One of the Pentium memory modules (DIMM 0, DIMM 1, DIMM 2, or DIMM 3) may be the failing item (see Finding parts, locations, and addresses).

Feature	Size
0426/0446	512 MB
0427/0447	1 GB

Note: At least **two** Pentium memory modules are required in positions DIMM 0 and DIMM 1, or positions DIMM 2 and DIMM 3.

MESSAGE

Messages provided with this symbolic FRU's description appear in the IBM i service action log (SAL).

If the word MESSAGE is listed in the IBM i SAL as a part number, the description field provides information regarding proper handling of the error.

This ends the procedure.

MOVEIOA

An incorrect hardware configuration was detected.

The I/O adapter used by a guest partition is on the same PCI bridge set as an I/O processor in another partition. Guest partition data may be lost if any of the following occur:

- A primary partition type D IPL is performed.
- The I/O adapter is moved to an IBM i partition.
- An error causes the logical partition (LPAR) configuration to not be used.

To correct the hardware configuration, either the I/O adapter or the I/O processor must be moved to a new card location. Use the LPAR Validation Tool (LVT) to create a valid configuration. For more information about the LPAR Validation Tool, see "Dynamic Logical Partitioning" at www.ibm.com/eserver/series/lpar/.

MSG0001

Resolve all B6006906 (or B7006906) errors before this one.

MSG0002

For HSL-1 I/O expansion units the problem might be that the RIO/HSL adapter got out of sync with the system.

Before exchanging FRUs, attempt to recover the I/O expansion unit by powering off and powering on the expansion unit. If the problem persists, exchange parts.

MSG0003

Replace the FRUs one at a time.

MSG0005

The operating system that controls these card locations does not support I/O processors.

NETSERV

The Integrated xSeries[®] Server (IXS) might be the failing item.

Call your Integrated xSeries Server (IXS) service provider.

NEXTLVL

Contact your next level of support.

NO_PNUM

Diagnostic firmware could not determine a part number for the FRU.

To determine the part number, exchange procedure, and other service information, do the following:

1. Record the location of the FRU from the user interface with which you are working.
2. Go to Part locations and location codes.
3. Use the location information to identify the name of the part in the "Locations" information.
4. Go to the Finding parts, locations, and addresses and determine the Field Replaceable Unit (FRU) part number for the part.

This ends the procedure.

NODECR

There is a problem with the node controller in a 9119-FHA processor book.

1. Is the SRC 1xxx1D10?

- **No:** Continue to the next step.
- **Yes:** Replace the node controller (NC) at Un-Pm-C41, in the book specified by the location code that was reported with the error.

2. Is the SRC 1xxx1D11?

- **No:** Return to the error log and look for another 1xxx yyyy SRC and follow the action for that SRC.
- **Yes:** Replace the node controller (NC) at Un-Pm-C42, in the book specified by the location code that was reported with the error.

NODEPL

The system processor backplane might be failing.

Use the following table to determine which FRU to replace.

Note: To simplify this information, secondary units on the 9406-MMA and the 9117-MMA are numbered 1 through 3. Secondary unit 1 is nearest to the primary unit. Secondary unit 3 being farthest away from the primary unit.

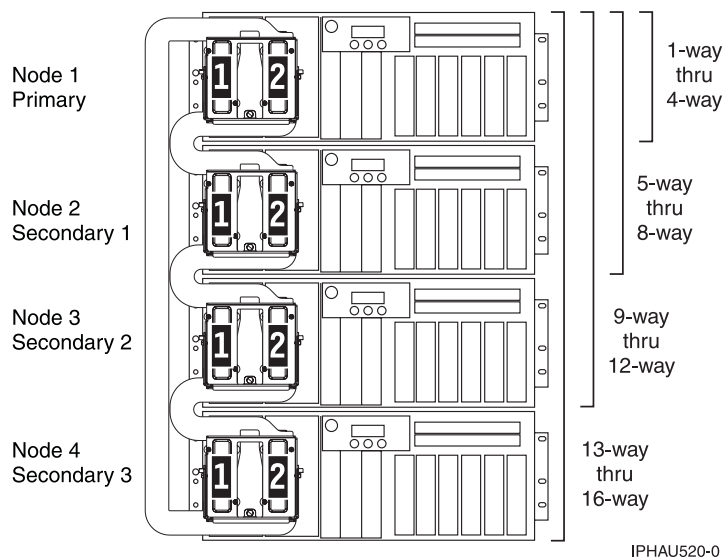

FRU name (replace in order, one at a time)	Location
For each unit, starting with the primary unit and then the secondary units:	
Primary unit, system processor backplane.	Un-P2
Secondary unit 1, system processor backplane (node backplane)	Un-P2
Secondary unit 2, system processor backplane (node backplane)	Un-P2
Secondary unit 3, system processor backplane (node backplane)	Un-P2

Use the following table to determine the part number for the field replaceable unit (FRU):

CCIN or FFC	Type and model	Part number	Description	Location code
	8203-E4A	42R7898	System backplane	Un-P1

	8204-E8A	10N9369	System backplane	Un-P1
27B0	9406-MMA, 9117-MMA	03N6902	System processor backplane	Un-P2

NOFRUS

No failing items are identified for the reference code.

NSCABLE

The cable between the Integrated xSeries[®] Adapter (IXA) card and the RS-485 port on the Integrated xSeries Server (IXS) is the failing item.

See Site and hardware planning.

NTDEVDR

The Windows server device driver might be causing the problem.

Refer to "Windows environment on iSeries" topic in the iSeries Information Center at <http://publib.boulder.ibm.com/infocenter/series/v5r4/index.jsp?topic=/rzahq/rzahqntspo.htm>, or contact your next level of support for assistance.

NTLANDD

The Windows server virtual LAN device driver might be causing the problem.

Refer to the "Windows environment on iSeries" topic in the iSeries Information Center at <http://publib.boulder.ibm.com/infocenter/series/v5r4/index.jsp?topic=/rzahq/rzahqntspo.htm>, or contact your next level of support for assistance.

NTOPSYS

The Windows server operating system may be causing the problem.

Refer to the "Windows environment on iSeries" document in the iSeries Information Center at <http://publib.boulder.ibm.com/infocenter/series/v5r4/index.jsp?topic=/rzahq/rzahqntspo.htm>, or contact your next level of support for assistance.

NTUSER

Windows server user problem.

This problem might be caused by:

- User-initiated action
- A Windows user application
- No keyboard or mouse attached to the Integrated xSeries Server (IXS)

Refer to the "Windows environment on iSeries" document in the iSeries Information Center at <http://publib.boulder.ibm.com/infocenter/series/v5r4/index.jsp?topic=/rzahq/rzahqntspo.htm>, or contact your next level of support for assistance.

NTVSCSI

The Windows server virtual SCSI device driver might be causing the problem.

Refer to the "Windows environment on iSeries" document in the iSeries Information Center at <http://publib.boulder.ibm.com/infocenter/series/v5r4/index.jsp?topic=/rzahq/rzahqntspo.htm>, or contact your next level of support for assistance.

OPT_CLN

The fiber channel connections need to be cleaned.

Use the fiber optic cleaning kit (part number 46G6844) and the fiber optic cleaning procedures in "SY27-2604 Fiber Optic Cleaning Procedures" for all fiber channel connections such as those used in optical high speed link (HSL) connections or fibre channel attached devices.

OPTLCBL

The cabling for an optical disk drive in the optical library needs to be checked.

The cabling may be incorrectly installed, or it may be defective.

For more information, refer to the 3995 Publications and Documentation Web site at <http://snjln02.sanjose.ibm.com/tape/tapetec.nsf/pages/3995pub>.

OPTLDRV

An optical disk drive in the optical library is failing.

For more information, refer to the 3995 Publications and Documentation Web site at <http://snjln02.sanjose.ibm.com/tape/tapetec.nsf/pages/3995pub>.

OPUSER

The failing item indicates that the operator of the system console or the control panel performed an incorrect action.

For more information, refer to the 3995 Publications and Documentation Web site at <http://snjln02.sanjose.ibm.com/tape/tapetec.nsf/pages/3995pub>.

OSLIC

An operating system has experienced a fatal error.

If the SRC that sent you here is of the form B6xx xxxx, then check for an IBM i PTF to correct the problem.

If the SRC that sent you here is of the form BAxx xxxx, then check for an AIX or Linux code patch to correct the problem.

If you need help finding the correct patches, or if this does not correct the problem, contact your next level of support.

OSTERM

The operating system in a partition has terminated abnormally.

Use the HMC to look for a partition that has failed. It should have the same SRC in the SRC display history for the failed partition. Use the SRC given in this error to resolve the problem.

Note: This error has not been automatically sent to your service provider.

If problems continue, call your next level of support.

PGDPART

Look here for information about PGDPART symbolic FRU.

1. Power off the server. For information about how to power off the server, see the service guide for the server on which you are working.
2. Verify that the service processor card, if present, is connected and seated correctly. See TWRCARD.
3. Verify that the power supplies are connected and seated properly. See PWRSPPLY.
4. Power on the server.
5. Is there a reference code 1xxx2600?
 - **No: Go to the next step.**
 - **Yes:** Exchange the following FRUs one at a time:
 - SPCN card, service processor card, or system backplane (as appropriate for the server, see the following tables for FRUs for the server on which you are working):
 - Power supplies
 - Memory DIMMs
 - Processor cards
 - Backplane

Use the following tables to determine the part number for the field replaceable unit (FRU):

8203-E4A, 9407-M15, 9408-M25

CCIN or FFC	Type and model	Part number	Description	Location code
	8203-E4A, 9407-M15, 9408-M25	42R7898	System backplane	Un-P1
	8203-E4A, 9407-M15, 9408-M25	44V4195	Power supplies, ac	Un-Ex
4520	8203-E4A, 9407-M15, 9408-M25	77P6497	512MB DDR2 memory card	Un-P1-Cx
4521	8203-E4A, 9407-M15, 9408-M25	77P6498	1GB DDR2 memory card	Un-P1-Cx
4522	8203-E4A, 9407-M15, 9408-M25	77P6499	2GB DDR2 memory card	Un-P1-Cx
4523	8203-E4A, 9407-M15, 9408-M25	77P6500	4GB DDR2 memory card	Un-P1-Cx
4524	8203-E4A, 9407-M15, 9408-M25	87H3621	8GB DDR2 memory card	Un-P1-Cx
2947	8203-E4A, 9407-M15, 9408-M25	77P7504	16GB DDR2 memory card	Un-P1-Cx

8204-E8A, 9409-M50

CCIN or FFC	Type and model	Part number	Description	Location code
	8204-E8A, 9409-M50	10N9369	System backplane	Un-P1
	8204-E8A, 9409-M50	44V3559	Power supplies, ac	Un-Ex
	8204-E8A, 9409-M50	42R6607	Power supplies, dc	Un-Ex
4520	8204-E8A, 9409-M50	77P6497	512MB DDR2 memory card	Un-P1-Cx-Cy
4521	8204-E8A, 9409-M50	77P6498	1GB DDR2 memory card	Un-P1-Cx-Cy

4522	8204-E8A, 9409-M50	77P6499	2GB DDR2 memory card	Un-P1-Cx-Cy
4523	8204-E8A, 9409-M50	77P6500	4GB DDR2 memory card	Un-P1-Cx-Cy
4524	8204-E8A, 9409-M50	87H3621	8GB DDR2 memory card	Un-P1-Cx-Cy
2947	8204-E8A, 9409-M50	77P7504	16GB DDR2 memory card	Un-P1-Cx-Cy
	8204-E8A, 9409-M50	10N9377	4.2 GHz POWER6, 2 Core Processor Card	Un-P1-Cx
	8204-E8A, 9409-M50	10N9380	4.7 GHz POWER6, 2 Core Processor Card	Un-P1-Cx

9406-MMA, 9117-MMA

CCIN or FFC	Type and model	Part number	Description	Location code
	9406-MMA, 9117-MMA	10N8752	Service processor card (the SPCN function is built into the service processor card for this system)	Un-P1-C11
	9406-MMA, 9117-MMA	See Finding parts, locations, and addresses.	Power supplies	Un-Ex
319B	9406-MMA, 9117-MMA	15R7433	512MB DDR2 memory card	Un-P2-Cx-Cy
319C	9406-MMA, 9117-MMA	15R7436	1GB DDR2 memory card	Un-P2-Cx-Cy
319E	9406-MMA, 9117-MMA	15R7439	2GB DDR2 memory card	Un-P2-Cx-Cy
319D	9406-MMA, 9117-MMA	15R7445	4GB DDR2 memory card	Un-P2-Cx-Cy
319F	9406-MMA, 9117-MMA	15R7448	8GB DDR2 memory card	Un-P2-Cx-Cy
	9406-MMA, 9117-MMA	10N9146	3.5 GHz POWER6, 2 Core Processor Card	Un-P2-Cx
	9406-MMA, 9117-MMA	10N9144	4.2 GHz POWER6, 2 Core Processor Card	Un-P2-Cx
	9406-MMA, 9117-MMA	10N9139	4.7 GHz POWER6, 2 Core Processor Card	Un-P2-Cx
	9406-MMA, 9117-MMA	42R7352	I/O Backplane	Un-P1
	9406-MMA, 9117-MMA	10N8550	System processor backplane	Un-P2

5790, 7311-D11

CCIN or FFC	Type and model	Part number	Description	Location code
	5790, 7311-D11	22R3958	Power supplies	Un-Ex
	5790, 7311-D11	80P6626	I/O drawer backplane	Un-P1

0595, 5095, 7311-D20

CCIN or FFC	Type and model	Part number	Description	Location code
	0595, 5095, 7311-D20	39J2781	Power supplies	Un-Ex
	0595, 5095, 7311-D20	39J0515	I/O drawer backplane	Un-P1

5796, 7314-G30

CCIN or FFC	Type and model	Part number	Description	Location code
	5796, 7314-G30	10N8867	SPCN Card	Un-P1-C8
	5796, 7314-G30	42R4491	Power supplies	Un-Ex
	5796, 7314-G30	See Finding parts, locations, and addresses.	I/O drawer backplane	Un-P1

6. Is there a reference code 1xxx 2602?

- **No: Go to the next step.**
- **Yes:** Exchange the following FRUs one at a time:
 - Service processor card
 - Voltage regulators
 - Backplane

Use the following tables to determine the part number for the field replaceable unit (FRU):

9406-MMA, 9117-MMA

CCIN or FFC	Type and model	Part number	Description	Location code
	9406-MMA, 9117-MMA	10N8752	Service processor card (the SPCN function is built into the service processor card for this system)	Un-P1-C11
	9406-MMA, 9117-MMA	42R8325	Voltage regulators	Un-P2-Cx (where x is equal to 3, 4, or 5)
	9406-MMA, 9117-MMA	42R7352	I/O Backplane	Un-P1

5790, 7311-D11

CCIN or FFC	Type and model	Part number	Description	Location code
	5790, 7311-D11	22R3958	Power supplies	Un-Ex
	5790, 7311-D11	80P6626	I/O drawer backplane	Un-P1

0595, 5095, 7311-D20

CCIN or FFC	Type and model	Part number	Description	Location code
	0595, 5095, 7311-D20	39J2781	Power supplies	Un-Ex
	0595, 5095, 7311-D20	39J0515	I/O drawer backplane	Un-P1

5796, 7314-G30

CCIN or FFC	Type and model	Part number	Description	Location code
	5796, 7314-G30	42R4491	Power supplies	Un-Ex
	5796, 7314-G30	10N8867	SPCN Card	Un-P1-C8
	5796, 7314-G30	See Finding parts, locations, and addresses.	I/O drawer backplane	Un-P1

7. Is there a reference code 2603?

- **No: This ends the procedure.**
- **Yes:** Exchange the following FRUs one at a time:
 - Service processor card
 - Power supplies
 - Backplane

Use the following tables to determine the part number for the field replaceable unit (FRU):

8203-E4A, 9407-M15, 9408-M25

CCIN or FFC	Type and model	Part number	Description	Location code
	8203-E4A, 9407-M15, 9408-M25	42R7898	System backplane (the service processor is part of the system backplane for this server)	Un-P1
	8203-E4A, 9407-M15, 9408-M25	44V4195	Power supplies, ac	Un-Ex

8204-E8A, 9409-M50

CCIN or FFC	Type and model	Part number	Description	Location code
	8204-E8A, 9409-M50	10N9369	System backplane (the service processor is part of the system backplane for this server)	Un-P1
	8204-E8A, 9409-M50	44V3559	Power supplies, ac	Un-Ex
	8204-E8A, 9409-M50	42R6607	Power supplies, dc	Un-Ex

9406-MMA, 9117-MMA

CCIN or FFC	Type and model	Part number	Description	Location code
	9406-MMA, 9117-MMA	10N8752	Service processor card (the SPCN function is built into the service processor card for this server)	Un-P1-C11
	9406-MMA, 9117-MMA	See Finding parts, locations, and addresses.	Power supplies	Un-Ex
	9406-MMA, 9117-MMA	42R7352	I/O Backplane	Un-P1

5790, 7311-D11

CCIN or FFC	Type and model	Part number	Description	Location code
	5790, 7311-D11	22R3958	Power supplies	Un-Ex
	5790, 7311-D11	80P6626	I/O drawer backplane	Un-P1

0595, 5095, 7311-D20

CCIN or FFC	Type and model	Part number	Description	Location code
	0595, 5095, 7311-D20	39J2781	Power supplies	Un-Ex
	0595, 5095, 7311-D20	39J0515	I/O drawer backplane	Un-P1

5796, 7314-G30

CCIN or FFC	Type and model	Part number	Description	Location code
	5796, 7314-G30	10N8867	SPCN Card	Un-P1-C8
	5796, 7314-G30	42R4491	Power supplies	Un-Ex
	5796, 7314-G30	See Finding parts, locations, and addresses.	I/O drawer backplane	Un-P1

PIOCARD

The hardware that controls PCI adapters and PCI card slots detected an error.

The failing component is the adapter in the location specified by the Direct Select Address (DSA) in the reference code. When possible, the diagnostic code will determine the FRU location for the serviceable event view.

1. Are you working from the serviceable event view and a PCI adapter or IOP card location is listed with this FRU?
 - **No:** Perform the following:
 - a. Record the DSA, which is word 7 of the reference code.
 - b. Locate the card specified in the DSA by performing the MABIP53 isolation procedure. Use the MABIP53 procedure to determine a card position when no location is given for a PCI adapter or IOP card FRU (MABIP53 is also available in the service guide for the server). Return here after locating the FRU and continue with the next step.
 - **Yes:** The error is located at the listed PCI adapter or IOP card location. Go to step 5.
2. Did you identify a single FRU location by using MABIP53 isolation procedure?
 - **No:** Continue with the next step.
 - **Yes:** This is the location of the failing item. Go to step 5.
3. Perform the following for each FRU location that you determined in the previous step:
 - a. Remove all of the adapter or IOP cards in the locations that are identified in the given range of PCI adapter or IOP card slots. Do not remove any FRUs with embedded adapters, only FRUs in PCI adapter or IOP card slots.
 - b. Replace each card one at a time.

Note: For IBM i[®] adapters controlled by IOPs, replace the IOP before any of the adapters. Power on the unit after you replace each card until either the problem reappears or you have replaced each card.

- c. Did the problem reappear?
- **No:** Continue with the next step.
 - **Yes:** The last card that you replaced before the problem appeared again is the failing item. Replace the PCI adapter or IOP card. **This ends the procedure.**
4. Did you identify a FRU with embedded adapters (for example a system backplane or an I/O backplane) when performing the MABIP53 isolation procedure?
- **No:** The problem might be intermittent. Contact your next level of support. **This ends the procedure.**
 - **Yes:** The problem is in the FRU with the embedded adapter. Continue with the next step and exchange that FRU.
5. Use the table below to locate the failing item(s).
- Note:** For multiple-drawer servers, each unit, starting with the primary unit and then the secondary units, use the following table to determine the part number for the field replaceable unit (FRU):

Table 16. Table 1. Failing items for symbolic FRU PIOCARD

CCIN or FFC	Type and model	Part number	Description	Location code
	8203-E4A, 9407-M15, 9408-M25	See description	PCI adapter or IOP. If you have detected a failing PCI adapter or IOP in a PCI slot of a system unit drawer, see Card positions to help identify the PCI slot that holds the failing adapter. Replace the PCI adapter or IOP that is in the failing slot.	U n-P1-C x
	8204-E8A, 9409-M50	See description	PCI adapter or IOP. If you have detected a failing PCI adapter or IOP in a PCI slot of a system unit drawer, see Card positions to help identify the PCI slot that holds the failing adapter. Replace the PCI adapter or IOP that is in the failing slot.	U n-P1-C x
	9406-MMA, 9117-MMA	See description	PCI adapter or IOP. If you have detected a failing PCI adapter or IOP in a PCI slot of a system unit drawer, see Card positions to help identify the PCI slot that holds the failing adapter. Replace the PCI adapter or IOP that is in the failing slot.	U n-P1-C x

Table 16. Table 1. Failing items for symbolic FRU PIOCARD (continued)

	5790, 7311-D11	See description	PCI adapter or IOP. If you have detected a failing PCI adapter or IOP in a PCI slot of an I/O expansion drawer, see Card positions to help identify the PCI slot that holds the failing adapter. Replace the PCI adapter or IOP that is in the failing slot.	U n-P1-C x
	0595, 5095, 7311-D20	See description	PCI adapter or IOP. If you have detected a failing PCI adapter or IOP in a PCI slot of an I/O expansion drawer, see Card positions to help identify the PCI slot that holds the failing adapter. Replace the PCI adapter or IOP that is in the failing slot.	U n-P x-C y
	5796, 7314-G30	See description	PCI adapter or IOP. If you have detected a failing PCI adapter or IOP in a PCI slot of an I/O expansion drawer, see Card positions to help identify the PCI slot that holds the failing adapter. Replace the PCI adapter or IOP that is in the failing slot.	U n-P x-C y
	5094, 5096, 5294, 5296	See description	PCI adapter or IOP. If you have detected a failing PCI adapter or IOP in a PCI slot of an I/O expansion drawer, see Card positions to help identify the PCI slot that holds the failing adapter. Replace the PCI adapter or IOP that is in the failing slot.	U n-P x-C y

Table 16. Table 1. Failing items for symbolic FRU PIOCARD (continued)

	8203-E4A, 9407-M15, 9408-M25	42R7898	System backplane. If you detected a failing I/O adapter that is embedded on a system backplane, replace the system backplane.	U n-P1
	8204-E8A, 9409-M50	10N9369	System backplane. If you detected a failing I/O adapter that is embedded on a system backplane, replace the system backplane.	U n-P1
	9406-MMA, 9117-MMA	42R7352	I/O backplane. If you detected a failing I/O adapter that is embedded on a system unit's I/O backplane, replace the I/O backplane.	U n-P1

This ends the procedure.

PLDUMP

A platform dump occurred.

1. Find the SRC that occurred with the platform dump.
 - a. On the command line, enter the Start System Service Tools command STRSST. If you cannot get to SST, use function 21 to get to the Dedicated Service Tools (DST). Go to Dedicated Service Tools in the Service functions section of the system's service guide.
 - b. On the **Start Service Tools Sign On** display, type in a user ID with QSRV authority and password.
 - c. Select **Start a service tool > Main storage dump manager > Work with copies of main storage dumps**.
 - d. Display the platform dump summary for the time that the platform dump occurred.
 - e. The SRC is the value in the "SRC word 1" field of the Platform Dump Summary screen.
2. Use the SRC from the Platform Dump Summary screen and find the SRC in the Service action log, see Searching the service action log. Using the Service Action Log is also available in the service guide for the system unit. Search for an entry in the Service Action Log (SAL) that matches the time, reference code, or resource of the reported problem. The SRC occurred at or before the time that the platform dump occurred.
3. Did you find the SRC in the service action log?
 - **Yes:** Use the SRC to service the system. **This ends the procedure.**
 - **No:** The dump should be sent back to development for analysis, if it has not already been sent. **This ends the procedure.**

PLUS

The list of possible failing items that are displayed online is not complete.

There is not enough space to display all of the failing items. See the complete list of possible failing items in the appropriate unit reference code table in Reference codes.

PPCIMIN

The affected component is a primary PCI bus in an I/O unit.

Use symbolic FRU PRI_PCI to determine the FRU(s) and service information.

This ends the procedure.

PPCISYS

The failing component is the primary PCI bus in a system unit.

Use symbolic FRU PRI_PCI to determine the FRU(s) and service information.

This ends the procedure.

PPCITWR

The failing component is the primary PCI bus under an HSL I/O bridge or RIO adapter in an I/O unit.

Use symbolic FRU PRI_PCI to determine the FRU(s) and service information.

PRI_PCI

The primary PCI bus generated under a RIO/HSL/12X adapter I/O bridge might be failing.

This bus can be in a system unit or I/O unit, and on some units this bus connects two FRUs.

1. Are you working from the serviceable event view and a card location is listed with this failing item?
 - **No:** Record the bus number value, BBBB, in word 7 of the reference code. Word 7 of the reference code allows you to determine the correct bus number, bus type, multi-adapter bridge number, multi-adapter bridge function number, and logical card number from the Direct Select Address (DSA), see DSA translation. Continue with the next step.
 - **Yes:** The listed card location is where the error is located. Continue with the next step.
2. Use the following table to determine the appropriate action:

Table 17. Symbolic FRU to perform for PRI_PCI

Type and model of unit containing the failing item	Action
8203-E4A, 8204-E8A, 9117-MMA, 9406-MMA, 9407-M15, 9408-M25, 9409-M50	Perform SYSBKPL.
5790, 7311-D11	There are two potential failing items. Perform SIADPCD. If the problem persists after powering on the frame or unit, then perform TWRPLNR. Attention: To prevent system VPD problems, do not replace both FRUs at the same time.
0595, 5095, 7311-D20	There are two potential failing items. Perform SIADPCD. If the problem persists after powering on the frame or unit, then perform TWRPLNR. Attention: To prevent system VPD problems, do not replace both FRUs at the same time.
5796, 7314-G30	There are two potential failing items. Perform SIADPCD. If the problem persists after powering on the frame or unit, then perform TWRPLNR. Attention: To prevent system VPD problems, do not replace both FRUs at the same time.

This ends the procedure.

PRIMIOA

Replace the storage I/O adapter to which the auxiliary cache I/O adapter is connected.

1. Find the location of the auxiliary cache I/O adapter:
 - a. Determine the address of the auxiliary cache I/O adapter. See The system reference code format description.
 - b. Determine the location of the auxiliary cache I/O adapter. See Part locations and location codes.
2. Are you working on a 571F/575B combination storage and auxiliary cache IOA card set (uses two card slot locations)?
 - **Yes:** Replace the entire card set. **This ends the procedure.**
 - **No:** Continue with the next step.
3. Trace the SCSI cable from the auxiliary cache I/O adapter to the storage I/O adapter. This is the storage I/O adapter that you should replace.
4. Replace the storage I/O adapter that you just identified.

This ends the procedure.

PSI_LNK

The path to the service processor might be the failing item.

Do one of the following:

- **For the 9406-MMA or 9117-MMA**, replace the service processor (SVCPROC) if you have not previously done so. If that does not resolve the problem, replace the backplane (SYSBKPL). If that does not resolve the problem, replace the processor card(s) (ANYPROC).
- **For the 8203-E4A, 8204-E8A, 9407-M15, 9408-M25, 9409-M50**, replace the system backplane (SYSBKPL). If that does not resolve the problem, replace the processor card(s) (ANYPROC).

PTFSRCH

Licensed Internal Code is the failing item.

Look for fixes (PTFs) associated with the reference code and have the customer apply them.

PTNNTWK

One or more connections to a partition have been lost.

1. Is the HMC reporting any other reference codes that indicate a loss of communication with other partitions?
 - **No:** Choose from the following:
 - If the partition is running IBM i, go to step 2.
 - If the partition is running AIX or Linux, go to step 3.
 - **Yes:** Resolve the first of these reference codes. **This ends the procedure.**
2. Open a 5250 console to the partition. There should be seven jobs running:
 - 4 of these jobs start with QCST*
 - 2 of these jobs start with QYUS*
 - 1 of these jobs start with QSVRM*Are all seven of these jobs running?
 - **Yes:** Go to step 4.
 - **No:** End all of those jobs that are still running and then issue the following command:

```
SBMJOB CMD(CALL PGM(QSYS/QCSTCTSRCD)) JOBD(QSYS/QCSTSRCD)
PRTDEV(*JOB) OUTQ(*JOB)
USER(*JOB) PRTTXT(*JOB) RTGDТА(RUNPTY50)
```

This ends the procedure.

3. Perform the following:
 - a. Open a virtual terminal console to the partition.
 - b. Verify that Service Resource Manager (SRM) is running properly by entering the following command:

```
lssrc -a |grep ServiceRM
```

If the state given for SRM is "inactive" then SRM is not running and needs to be restarted. If the state given is "active", then go to step 4.

4. Has the partition logged any LAN adapter or other LAN reference codes?
 - **No:** Work with the customer to find and resolve any network problems between the HMC and the partition. **This ends the procedure.**
 - **Yes:** Resolve these reference codes. **This ends the procedure.**

PWRCBL

The failing item is the SPCN frame-to-frame cable or adapter.

Use the following table to determine the part number for the field replaceable unit (FRU):

CCIN or FFC	Type and model	Part number	Description	Location code
1464, 6008	Any	22R5219	SPCN cable (6 meters)	
1465, 6007	Any	22R5221	SPCN cable (15 meters)	
1466, 6029	Any	22R5222	SPCN cable (30 meters)	
0369	Any	41U0128	Optical SPCN cable (100 meters)	
	Any	39J3865	SPCN optical adapter	

PWROC

This is not a valid symbolic FRU for this machine type.

PWRSPLY

A power supply might be the failing item.

Attention: When replacing a redundant power supply, a 1xxx1504, 1xxx1514, 1xxx1524, or 1xxx1534 reference code may surface in the error log. If you just removed and replaced the power supply in the location associated with this reference code, and the power supply became ready (ac power good LED is illuminated) after the install, disregard this reference code. If you had not previously removed and replaced a power supply, the power supply did not become ready after installation, or there are repeated fan fault errors after the power supply replacement, continue to follow this procedure.

Note: The following table provides information about power supply LEDs.

LED	Description
AC input good	This LED is green and will be on (lit) if the ac input voltage is present and off (not lit) if the ac input voltage is not present. For normal system operation, this LED will be on solid.
DC good	This LED is green and will be on solid if the power supply output voltages are correct. If the power supply control voltage is present and the power supply outputs are not powered up, the power supply is in standby and the dc good LED will blink at a rate of 1-3 times per second. The dc good LED will be off if both the power supply control voltage and the output voltages are bad. For normal system operation, this LED will be on solid.
Identify	The identify LED is amber and will be toggled on and off at a 4 second rate, ten seconds after the application of input power to the supply, if serial communication isn't established with the service processor. For normal system operation, this LED will be off.

1. Is the reference code 1xxx15xx 1xxx60x6, or 1xxx71xx?
 - **No:** Continue with the next step.
 - **Yes:** Perform the following:
 - a. Find the unit reference code in the following table to determine the FRU part number and location for the failing power supply.
 - b. Ensure that the power cables to the power supply are properly connected and seated. The green Power Good LED on the power supply will illuminate when power is correctly connected to the power supply.
 - c. Is the reference code 1xxx1510 or 1xxx1520 and is the failing unit configured with a redundant power supply option (or dual line cord feature)?
 - **Yes:** Before replacing any parts, perform isolation procedure PWR1911.
 - **No:** Continue with step 1.d.
 - d. Replace the failing power supply (see the following table to determine which power supply to replace and its location). **Attention:** For reference codes 1xxx1510 and 1xxx1520 before replacing any parts on a dual line cord system, perform isolation procedure PWR1911. Before replacing parts on a single line cord system, check the ac jumper to the power supply.
 - e. Perform the following if the new power supply does not fix the problem:
 - 1) Reinstall the original power supply.
 - 2) Try the new power supply in each of the other positions listed in the table.
 - 3) If the problem still is not fixed, reinstall the original power supply and go to the next FRU in the list.
 - 4) For reference codes 1xxx1510 and 1xxx1520 if a problem persists after replacing the power supply, exchange the power distribution backplane, contact your next level of support.
 - f.

Use the following table to determine the part number for the field replaceable unit (FRU):

Unit reference code	Type-model or feature code	Part number	Description	Location code
1510, 1511, 1512, 1513, 1514, 7110	8203-E4A, 9407-M15, 9408-M25	44V4195	Power supply, ac	Un-E1

1520, 1521, 1522, 1523, 1524, 7120	8203-E4A, 9407-M15, 9408-M25	44V4195	Power supply, ac	Un-E2
1510, 1511, 1512, 1513, 1514, 7110	8204-E8A, 9409-M50	44V3559	Power supply, ac	Un-E1
1520, 1521, 1522, 1523, 1524, 7120	8204-E8A, 9409-M50	44V3559	Power supply, ac	Un-E2
1510, 1511, 1512, 1513, 1514, 7110	8204-E8A, 9409-M50	42R6607	Power supply, dc	Un-E1
1520, 1521, 1522, 1523, 1524, 7120	8204-E8A	42R6607	Power supply, dc	Un-E2
1510, 1511, 1512, 1513, 1514, 7110	9406-MMA, 9117-MMA	See Finding parts, locations, and addresses.	Power supply	Un-E1
1520, 1521, 1522, 1523, 1524, 7120	9406-MMA, 9117-MMA	See Finding parts, locations, and addresses.	Power supply	Un-E2
1510, 1511, 1512, 1513, 1514, 1516, 1517	5790, 7311-D11	22R3958	Power supply	Un-E1
1520, 1521, 1522, 1523, 1524, 1526, 1527	5790, 7311-D11	22R3958	Power supply	Un-E2
1510, 1511, 1512, 1513, 1514, 1516, 1517	0595, 5095, 7311-D20	39J2781	Power supply	Un-E1
1520, 1521, 1522, 1523, 1524, 1526, 1527	0595, 5095, 7311-D20	39J2781	Power supply	Un-E2
1510, 1511, 1512, 1513, 1514, 1516, 1517	5796, 7314-G30	42R4491	Power supply	Un-E1
1520, 1521, 1522, 1523, 1524, 1526, 1527	5796, 7314-G30	42R4491	Power supply	Un-E2
1510, 1511, 1512, 1513, 1514, 1516, 1517	5094	39J5273	Power supply	Un-P01
1520, 1521, 1522, 1523, 1524, 1526, 1527	5094	39J5273	Power supply	Un-P02
1530, 1531, 1532, 1533, 1534, 1536, 1537	5094	39J5273	Power supply	Un-P03
1507, 1510, 1511, 1512, 6006	5802	See Finding parts, locations, and addresses.	Power supply (DCA), ac	Un-E1
1517, 1520, 1521, 1522, 6016	5802	See Finding parts, locations, and addresses.	Power supply (DCA), ac	Un-E2

This ends the procedure.

2. Is the reference code 1xxx2600, 1xxx2601, 1xxx2603, 1xxx2605, or 1xxx2606?

- **No:** Continue with the next step.
- **Yes:** Perform the following:
 - a. Find the unit reference code in the following table to determine the FRU part number and location for the failing power supply.
 - b. Replace the failing power supply.
 - c. Perform the following if the new power supply does not fix the problem:
 - 1) Reinstall the original power supply.

- 2) Try the new power supply in each of the other positions listed in the table.
- 3) If the problem still is not fixed, reinstall the original power supply and go to the next FRU in the list.

Use the following table to determine the part number for the field replaceable unit (FRU):

Unit reference code	Type-model or feature code	Part number	Description	Location code
2600, 2601, 2603, 2605, or 2606	9406-MMA, 9117-MMA	See Finding parts, locations, and addresses.	Power supply	Un-E1 or Un-E2
2600, 2601, 2603, 2605, or 2606	5790, 7311-D11	22R3958	Power supply	Un-E1 or Un-E2
2600, 2601, 2603, 2605, or 2606	0595, 5095, 7311-D20	39J2781	Power supply	Un-E1 or Un-E2
2600, 2601, 2603, 2605, or 2606	5796, 7314-G30	42R4491	Power supply	Un-E1 or Un-E2
2600, 2601, 2603, 2605, or 2606	5094	39J5273	Power supply	Un-P1, Un-P2, or Un-P3

This ends the procedure.

3. Is the reference code 1xxx1601, 1xxx8455, or 1xxx8456?
 - **No:** Continue with the next step.
 - **Yes:** One of the power supplies is missing, and must be installed. Use the following table to determine which power supply is missing, and install the power supply.

Reference code	Missing power supply
1xxx1601	Un-E1 or Un-E2
1xxx8455	Un-E1
1xxx8456	Un-E2

4. Is the reference code 1xxx314x, 1xxx3156, or 1xxx3157?
 - **No:** Continue with the next step.
 - **Yes:** Replace the power supply (DCA) at location Un-E1 in the 5802 expansion unit. If that does not resolve the problem, replace the power supply (DCA) at location Un-E2 in the 5802 expansion unit. **This ends the procedure.**
5. Is the reference code 1xxx3154 or 1xxx3155?
 - **No:** Return to the "Starting a service call" procedure. **This ends the procedure.**
 - **Yes:** Replace the power supply (DCA) at location Un-E2 in the 5802 expansion unit. If that does not resolve the problem, replace the power supply (DCA) at location Un-E1 in the 5802 expansion unit. **This ends the procedure.**

PWRVPD

Use ASMI to set the configuration ID and MTMS value.

To perform this operation, verify that the following prerequisites have been met:

- The server must be powered on to firmware standby or firmware running state.
- The expansion unit must be correctly installed in the system configuration and have ac power.
- Your authority level must be one of the following:
 - Administrator
 - Authorized service provider

1. Login in to the Advanced System Management Interface (ASMI).
2. Expand **System Configuration**.
3. Select **Configure I/O Enclosures**.
4. Select **Clear inactive enclosures**.
5. If you were directed here from a FRU replacement procedure, the FRU that was replaced contained non-volatile storage where information about the expansion unit's machine type-model-serial (MTMS) was stored. It is necessary to restore the expansion unit's MTMS now. It might also be necessary to set or change the expansion unit's configuration ID (power control network identifier). The non-volatile storage in which the expansion unit's MTMS value is stored in a new replacement FRU is uninitialized. When power is first applied, the system detects the uninitialized value and assigns an obvious, temporary unique value of the form TMP x.xxx.xxxxxxx, where x can be any character 0-9 and A-Z. As a result, the initial location code of the expansion unit is set to UTMP x.xxx.xxxxxxx. To perform power off procedures or to change settings for an expansion unit that contains uninitialized non-volatile storage, you must first use the new UTMP x.xxx.xxxxxxx location code (see the list below) when selecting the expansion unit in the ASMI menus.

Notes:

- a. Do not remove the ac power cord after powering off the expansion unit.
 - b. If the expansion unit does not immediately appear on the service utility used to power off the expansion unit, refresh the utility periodically for up to ten minutes until it does. If it still does not appear, return to step 1 and repeat this procedure.
 - c. If you were directed here from a replacement procedure, remember to use the new UTMP x.xxx.xxxxxxx location code when selecting the expansion unit to power off.
 - d. If you were instructed by the procedure that sent you here when you were powering off the expansion unit to use panel function 69 to power on the expansion unit, perform panel function 69 now (with the control panel set to manual mode) from the system unit control panel (even though the expansion unit is already on).
6. From the ASMI utility, expand **System Configuration**.
 7. Select **Configure I/O Enclosures**.
 8. Compare the power control network identifier value shown for the expansion unit you are working with to the power control network identifier (configuration ID) values in the following list. Compare the type-model and serial number values shown for the expansion unit you are working with to the type, model, and serial values on the label on the expansion unit. If any changes must be made, go to step 9. Otherwise go to step 21.
- Note:** Serial numbers are case sensitive. (All alpha characters contained in the serial number must be entered as a capital letter.)
- 88 for 7311-D11 expansion units.
 - 8C for 7311-D20 expansion units.
 - 8D for the 7314-G30 expansion units.
9. If the server is powered on to firmware running state, go to the next step. If the server is powered on to firmware standby state go to step 11.
 10. See the following notes, then go to "Powering off an expansion unit" in the service guide for the system unit. Then continue with step 11.

Notes[®]:

- a. Do not disconnect the ac power cables after powering off the expansion unit.
- b. If the expansion unit does not immediately appear on the service utility used to power off the expansion unit, refresh the utility periodically for up to ten minutes until it does. If it still does not appear, go step 1 and repeat this procedure.
- c. Remember to use the new UTMP x.xxx.xxxxxxx location code when selecting the expansion unit to power off if you were directed here from a replacement procedure.

- d. If you were instructed by the procedure that sent you here when you were powering off the expansion unit to use panel function 69 to power on the expansion unit, perform panel function 69 now (with the control panel set to manual mode) from the system unit control panel (even though the expansion unit is already on).
11. From the ASMI utility, expand **System Configuration**.
12. Select **Configure I/O Enclosure**.
13. Select the expansion unit with which you are working.
14. Select **Change settings**.
15. If in step 8 you determined that the power control network identifier value is not correct, enter the correct value now.
16. If in step 8 you determined that the type-model and serial number values are not correct, enter the correct values now.
Note: Serial numbers are case sensitive. (All alpha characters contained in the serial number must be entered as a capital letter.)
17. Click **Save settings** to complete the operation
18. Verify that the values you just entered are reflected in the power control network identifier, type-model, serial number, and location code columns for the expansion unit with which you are working. Do not use the browser back button to do this. Rather, expand **System Configuration**. Then select **Configure I/O Enclosures**.
Note: Serial numbers are case sensitive. All alpha characters contained in the serial number must be entered as a capital letter.
19. If the server is powered on to firmware standby state and you entered a new power control network identifier in step 15, the expansion unit will power off and back on automatically. If this is the case, go to step 21. Otherwise go to the next step.
20. Power on the expansion unit.
 - If the system is not HMC-managed, disconnect all ac power to the expansion unit by disconnecting the ac cables from the power supplies on the expansion unit. Wait for the display panel to go off, and then reconnect the ac power cables. The expansion unit will power on automatically.
 - If the system is HMC-managed, power on the expansion unit using the Power On/Off unit utility. If the values you just entered are not immediately reflected in the location code of the expansion unit in the Power On/Off unit utility, restart the utility periodically for up to ten minutes until the values you entered are reflected. For information about powering on an expansion unit, go to "Powering on an expansion unit" in the system unit's service guide, then continue with the next step.
21. Log off and close ASMI.
22. Return to the procedure that sent you here.

QDCCRLS

Licensed Internal Code is the failing item.

Look for PTFs associated with the reference code and have the customer apply them.

QSYSOPR

Look here for information about QSYSOPR symbolic FRU.

Look in the System Operator message queue for a message with the same date and time as the problem. Perform any actions defined in the message.

REFER

Look here for information about REFER symbolic FRU.

If the first four characters of the SRC are 3995, consult the All 3995 Publications and Documentation Web site at <http://snjInt02.sanjose.ibm.com/tape/tapetec.nsf/pages/3995pub>. If the first four characters of the SRC are 3996, consult the 3996 Maintenance Information shipped with the 3996 Optical Library.

REM_NIC

Look here for information about REM_NIC symbolic FRU.

One end of the failed link is a system unit other than the one reporting this error.

In a cluster, all system units should send a warning to the other system units in the cluster when they are about to perform a controlled power down. This error could occur when a system unit leaves the cluster without issuing any warning to other system units. If the system unit is not reporting due to a failed cable or HSL hardware, replacing the FRUs in this error log entry will correct the problem.

However, the system unit may have been powered down immediately, or powered down because of an error. If this is the case, service any errors in the other system unit, or power the other system unit back on. When the other system unit reports in, the loop will be complete and this error can be closed.

This ends the procedure.

REM_SYS

Look here for information about REM_SYS symbolic FRU.

A problem has occurred in a remote system that is in an IBM i[®] HSL OptiConnect loop.

If the value of the first half of word 7 in the reference code is greater than or equal to 0680, then this value is the hexadecimal RIO/HSL loop number. The Service Action Log (SAL) code will attempt to identify the RIO/HSL loop number of the local system and the serial number of the remote system as a portion of the part description for this symbolic FRU. If the SAL could not identify the serial number of the remote system, then check all the systems which are connected to the local RIO/HSL loop identified in the reference code or the SAL. Search the SAL of the remote system(s) for hardware and LIC problems. Correct any problems you find with LIC or Network Interface Controller (NIC) / RIO controller hardware.

This ends the procedure.

SASCABL

The SAS device cable might be failing.

If the device is an internal device (not in an external disk expansion unit), there is no cable. Continue with the next failing item in the failing item list. **This ends the procedure.**

If the device is in an external expansion unit, ensure the cables are connected correctly. If they are not connected correctly, fix the cable connection problem. If they are already connected correctly, replace the cables. See "Serial attached SCSI cable planning," in Site and hardware planning for cable FRU part numbers. **This ends the procedure.**

SASEXP

The expander or ESM (Enclosure Services Manager) might be failing.

Perform the following:

1. Does the SRC that sent you here begin with 509A?
 - **No:** Go to step step 3.
 - **Yes:** Continue with the next step.
2. Find the resource name that this error was logged against. This can be obtained from the Service Action Log (see Searching the service action log). Then, using the resource name, perform the following:
 - a. Access SST or DST.
 - b. Select **Start a Service Tool**.
 - c. Select **Hardware Service Manager**.
 - d. Select **Locate resource by resource name**.
 - e. Enter the resource name that this error was logged against.
 - f. Select the **Associated packaging resource(s) option for the expander**.
 - g. Select the **Display detail for the expander/ESM** option to display its physical location.

Replace the expander/ESM at the location displayed.

CCIN or FFC	Type and model	Part number	Description	Location code
	8203-E4A, 9407-M15, 9408-M25	07P6910	Media and Disk drive backplane	U n-P2
	8203-E4A, 9407-M15, 9408-M25	44V4270	Media and Disk drive backplane with port expander	U n-P2
	8204-E8A, 9409-M50	10N9532	Media and Disk drive backplane	U n-P2
	8204-E8A, 9409-M50	10N9664	Media and Disk drive backplane with port expander	U n-P2
293D	9406-MMA, 9117-MMA	10N8968	Removable media enclosure assembly (includes the media backplane)	U n-P3
	9406-MMA, 9117-MMA	10N9088	Disk drive backplane	U n-P3
	5720, 7214-1U2	95P4036	Electronics tray, also known as the Enclosure Services Manager (ESM)	U n-P1
509A	5886	44V3937	Enclosure Services Manager (ESM)	U n-C1, U n-C2

This ends the procedure.

3. Is the device an internal device (not in an external expansion unit)?
 - **No:** Replace the expanders/ESMs in the external expansion unit one at a time until the problem is resolved. **This ends the procedure.**
 -

CCIN or FFC	Type and model	Part number	Description	Location code
-------------	----------------	-------------	-------------	---------------

	5720, 7214-1U2	95P4036	Electronics tray, also known as the Enclosure Services Manager (ESM)	U n-P1
509A	5886	44V3937	Enclosure Services Manager (ESM)	U n-C1, U n-C2

- **Yes:** The expander is integrated into the device backplane.

If you have not replaced the device backplane, replace it. Use the following table to determine the part number for the field replaceable unit (FRU). If you have already replaced the device backplane, continue with the next failing item in the failing item list. **This ends the procedure.**

CCIN or FFC	Type and model	Part number	Description	Location code
	8203-E4A, 9407-M15, 9408-M25	07P6910	Media and Disk drive backplane	U n-P2
	8203-E4A, 9407-M15, 9408-M25	44V4270	Media and Disk drive backplane with port expander	U n-P2
	8204-E8A, 9409-M50	10N9532	Media and Disk drive backplane	U n-P2
	8204-E8A, 9409-M50	10N9664	Media and Disk drive backplane with port expander	U n-P2
293D	9406-MMA, 9117-MMA	10N8968	Removable media enclosure assembly (includes the media backplane)	U n-P3
	9406-MMA, 9117-MMA	10N9088	Disk drive backplane	U n-P3

SI_CARD

The failing component is the RIO/HSL or 12X adapter card in the system unit.

Use the following table to determine the part number for the field replaceable unit (FRU):

CCIN or FFC	Type and model	Part number	Description	Location code
	8203-E4A, 9407-M15, 9408-M25	10N9982	RIO-2/HSL-2 adapter	U n-P1-C x
	8203-E4A, 9407-M15, 9408-M25	44V4645	GX DUAL-PORT 12X HCA	U n-P1-C x
	8204-E8A, 9409-M50	10N6859	RIO-2/HSL-2 adapter	U n-P1-C x
	8204-E8A, 9409-M50	10N9529	GX DUAL-PORT 12X HCA	U n-P1-C x
	9406-MMA, 9117-MMA	39J0792	RIO-2/HSL-2 adapter	U n-P1-C x
	9406-MMA, 9117-MMA	10N8782	GX DUAL-PORT 12X HCA	U n-P1-C x

This ends the procedure.

SI_PHB

The HSL I/O bridge/RIO adapter hardware in a system or I/O unit is failing.

Follow this procedure to identify the failing component to exchange.

1. Are you working from the serviceable event view and a card location is listed with this FRU?
 - **Yes:** Then the listed card location is where the error is located. Continue with the next step.
 - **No:** Record the bus number value, BBBB, in word 7 of the reference code. Word 7 of the reference code allows you to determine the correct bus number, bus type, multi-adapter bridge number, multi-adapter bridge function number, and logical card number from the Direct Select Address (DSA). See the section entitled, "Breaking down a RIO/HSL or PCI bus reference code" in the service guide for the system unit on which you are working. Search for the decimal bus number, using one of the following, to determine which frame or I/O unit contains the failing item.
 - the HMC's system configuration user interface (if an HMC is controlling the system)
 - IBM i Hardware Service Manager (HSM)
 - or the System Configuration Listing

Record the unit type or feature and continue with the next step.

2. Use the following table to determine the part number for the field replaceable unit (FRU):

CCIN or FFC	Type and model	Part number	Description	Location code
	8203-E4A, 9407-M15, 9408-M25	42R7898	System backplane	U n-P1
	8204-E8A, 9409-M50	10N9369	System backplane	U n-P1
	9406-MMA, 9117-MMA	42R7352	I/O backplane	U n-P1
	5790, 7311-D11	03N5633	RIO/HSL adapter	U n-P1-C7
	0595, 5095, 7311-D20	39J0523	RIO/HSL adapter	U n-P1-C05
	5796, 7314-G30	10N8782	RIO/HSL adapter	U n-P1-C7

This ends the procedure.

SIADPCD

The failing component is the HSL I/O bridge card, RIO adapter card, or a Dual-port 12X HCA in an I/O unit

Use the following table to determine the part number for the field replaceable unit (FRU):

CCIN or FFC	Type and model	Part number	Description	Location code
2886	5094, 5096, 5294, 5296	39J0669	RIO/HSL-2 adapter	Un-CB1-C10
2887	5094, 5096, 5294, 5296	39J0527	RIO/HSL-2 adapter	Un-CB1-C10
28E7	5094, 5096, 5294, 5296	39J0523	RIO-2/HSL-2 adapter	Un-CB1-C10
	5790, 7311-D11	03N5633	RIO/HSL-2 adapter	Un-P1-C7
	0595, 5095, 7311-D20	39J0523	RIO/HSL-2 adapter	Un-P1-C05
	5796, 7314-G30	10N8782	Dual-port 12X HCA	Un-P1-C7

SICNTRL

The failing component is the RIO, HSL, or 12X controller.

1. Do you have a location code for this FRU in the serviceable event view?

- **No:** Continue with the next step.
 - **Yes:** Go to step 4.
2. Is the first half of word 7 of the reference code greater than or equal to 0680?
 - **No:** Continue with the next step.
 - **Yes:** This is a valid loop number and can be correlated to an adapter location in the server using the procedure Converting the loop number to RIO/HSL/12X port location labels. Record the location code and go to step 4.
 3. Because the first four characters of word 7 are less than 0680, they represent the system bus number. Do you have access to a system configuration listing?
 - **No:** Contact your next level of support. **This ends the procedure.**
 - **Yes:** Use the system configuration listing to determine which HSL, RIO, or 12X loop number the system bus is connected to then determine the FRU location code using the tables in Converting the loop number to RIO/HSL/12X port location labels. Once you have the FRU's location, continue with the next step.
 4. Use the following table to find the replacement FRU part number for the FRU location identified previously in this procedure.

CCIN or FFC	Type and model	Part number	Description	Location code
	8203-E4A, 9407-M15, 9408-M25	10N9982	RIO-2/HSL-2 adapter	U n-P1-C x
	8203-E4A, 9407-M15, 9408-M25	44V4645	GX DUAL-PORT 12X HCA	U n-P1-C x
	8204-E8A, 9409-M50	10N9180	RIO-2/HSL-2 adapter	U n-P1-C x
	8204-E8A, 9409-M50	10N9533	GX DUAL-PORT 12X HCA	U n-P1-C x
	9406-MMA, 9117-MMA	39J0792	RIO-2/HSL-2 adapter	U n-P1-C x
	9406-MMA, 9117-MMA	42R6849	GX DUAL-PORT 12X HCA	U n-P1-C x
	8203-E4A, 9407-M15, 9408-M25	42R7898	System backplane	U n-P1
	8204-E8A, 9409-M50	10N9369	System backplane	U n-P1
	9406-MMA, 9117-MMA	42R7352	I/O backplane	U n-P1

This ends the procedure.

SIIOADP

The RIO adapter/HSL I/O bridge might be failing.

Note: In the following procedures, the term **RIO adapter** refers to either a RIO adapter or an HSL I/O bridge, depending on the server to which it applies.

1. Is a location for this FRU given in the serviceable event view?
 - **Yes:** Use that location and Table 2 to find and replace the failing part. **This ends the procedure.**
 - **No:** Continue with the next step. **Note:** In most circumstances, the SRC logged by the system firmware calls out a FRU list. In very few circumstances (as in the following examples), the failure requires immediate system termination. **Example: Symptoms**
 - 1 B7006981 RIO/HSL (bridge) bus adapter failure SRC
 - 2 XXXXX62 SRC Format 62
 - 3 00010002 Component ID field must be an exact match

```

4 14993203 Code Model and PRC must be an exact match
5 FRUCALLO Decode this when the SRC is 6906 or 6907
6 FRUCALLO Decode this when the SRC is 6981
7 00000000

```

Example: SRC 6981

```

1 B7006981
2 00000062
3 00010002
4 14993203
6 00044000
7 00000000

```

When immediate termination occurs, the SRC does not provide a FRU callout. The following steps describe how to determine the FRU callout.

2. Isolate the RIO adapter FRU indicated by the data in word 5 (when the SRC is 6906 or 6907) or word 6 (when the SRC is 6981) of the SRC by completing the following steps: **Note:** Replace only the FRU with the RIO/HSL adapter FRU.
 - a. Use the following example as a guide to locate and record the following binary values from word 5 or word 6 of the SRC:
 - RIO hub ID
 - RIO port pair ID
 - RIO loop position

Example: Decoding FRU Callout 00044000

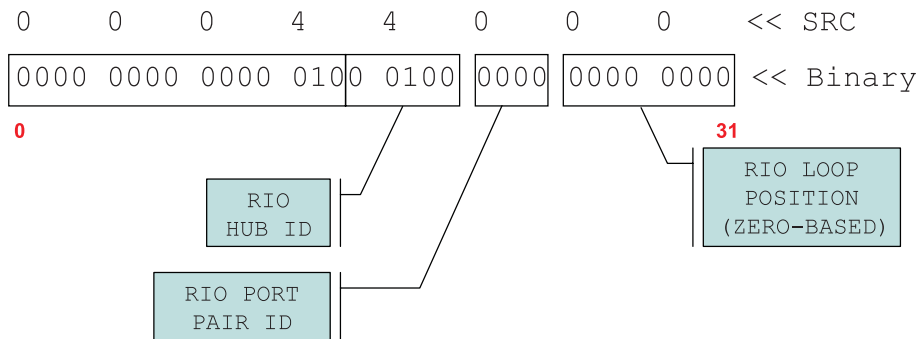

Figure 3. Decoding FRU Callout 00044000

- b. Convert the binary values for the RIO hub ID, the RIO port pair ID, and the RIO loop position to decimal. Record these values for later use.
3. Each RIO hub controls two RIO loops, specified as the **first** and **second** loop. Use the following list to determine and record which of these two RIO loops is indicated in word 6 of the SRC:
 - When the binary value of the RIO port pair ID is 0000, the SRC indicates the **first** RIO loop
 - When the binary value of the RIO port pair ID is 0001, the SRC indicates the **second** RIO loop
4. To isolate the failing RIO adapter, you will walk the cabling for the specified RIO loop from the leading port to the trailing port. To determine the RIO loop number and RIO port location code for the leading port, do the following:
 - a. Make sure you have the following values at hand, then continue with the next step.
 - The decimal value for the RIO hub ID
 - The RIO loop indicated by the RIO port pair ID

- b. Compare the values from the previous step to the location tables and graphics for your server below. Record the values for the RIO loop number and the RIO port location code. Then continue with the next step.

Loop location information and diagram for 8203-E4A, 9407-M15, 9408-M25

Table 18. 8203-E8A SIIOADP RIO loop location information

Hub (decimal)	Loop number(hex / dec)	Location code for leading port of the loop
1	0686/1670	P1-C8-T2
1	0781/1921	P1-C8-T2
2	0688/1672	P1-C6-T2
2	0782/1922	P1-C6-T2

8203-E4A, 9407-M15, 9408-M25 RIO loop diagram

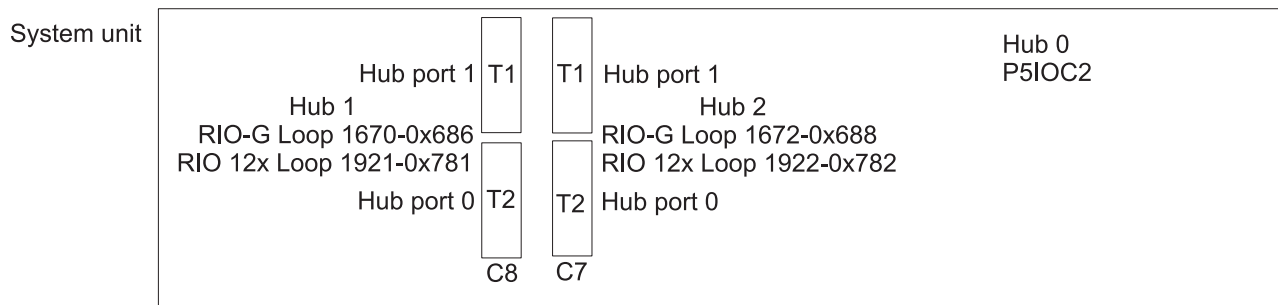

Figure 4. 8203-E4A, 9407-M15, 9408-M25 RIO loop diagram

Loop location information and diagram for 8204-E8A, 9409-M50

Table 19. 8204-E8A, 9409-M50 SIIOADP RIO loop location information

Hub (decimal)	Loop number(hex / dec)	Location code for leading port of the loop
1	0686/1670	P1-C8-T2
1	0781/1921	P1-C8-T2
2	0688/1672	P1-C7-T2
2	0782/1922	P1-C7-T2

8204-E8A, 9409-M50 RIO loop diagram

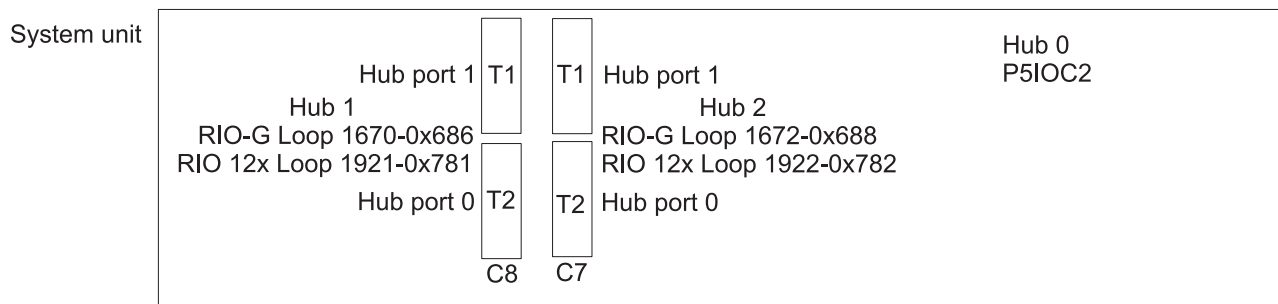

Figure 5. 8204-E8A, 9409-M50 RIO loop diagram

Loop location information and diagram for 9117-MMA and 9406-MMA

Table 20. 9117-MMA, 9406-MMA SIIODP RIO loop location information

System unit drawer	Hub (decimal)	Loop number(hex / dec)	Location code for leading port of the loop
0	1	0686/1670	P1-C8-T2
0	1	0781/1921	P1-C8-T2
0	2	0688/1672	P1-C9-T2
0	2	0782/1922	P1-C9-T2
1	9	0696/1686	P1-C8-T2
1	9	0789/1929	P1-C8-T2
1	10	078A/1930	P1-C9-T2
1	10	0698/1688	P1-C9-T2
2	17	06A6/1702	P1-C8-T2
2	17	0791/1937	P1-C8-T2
2	18	06A8/1704	P1-C9-T2
2	18	0792/1938	P1-C9-T2
3	25	06B6/1718	P1-C8-T2
3	25	0799/1945	P1-C8-T2
3	26	06B8/1720	P1-C9-T2
3	26	079A/1946	P1-C9-T2

9406-MMA and 9117-MMA RIO loop diagram

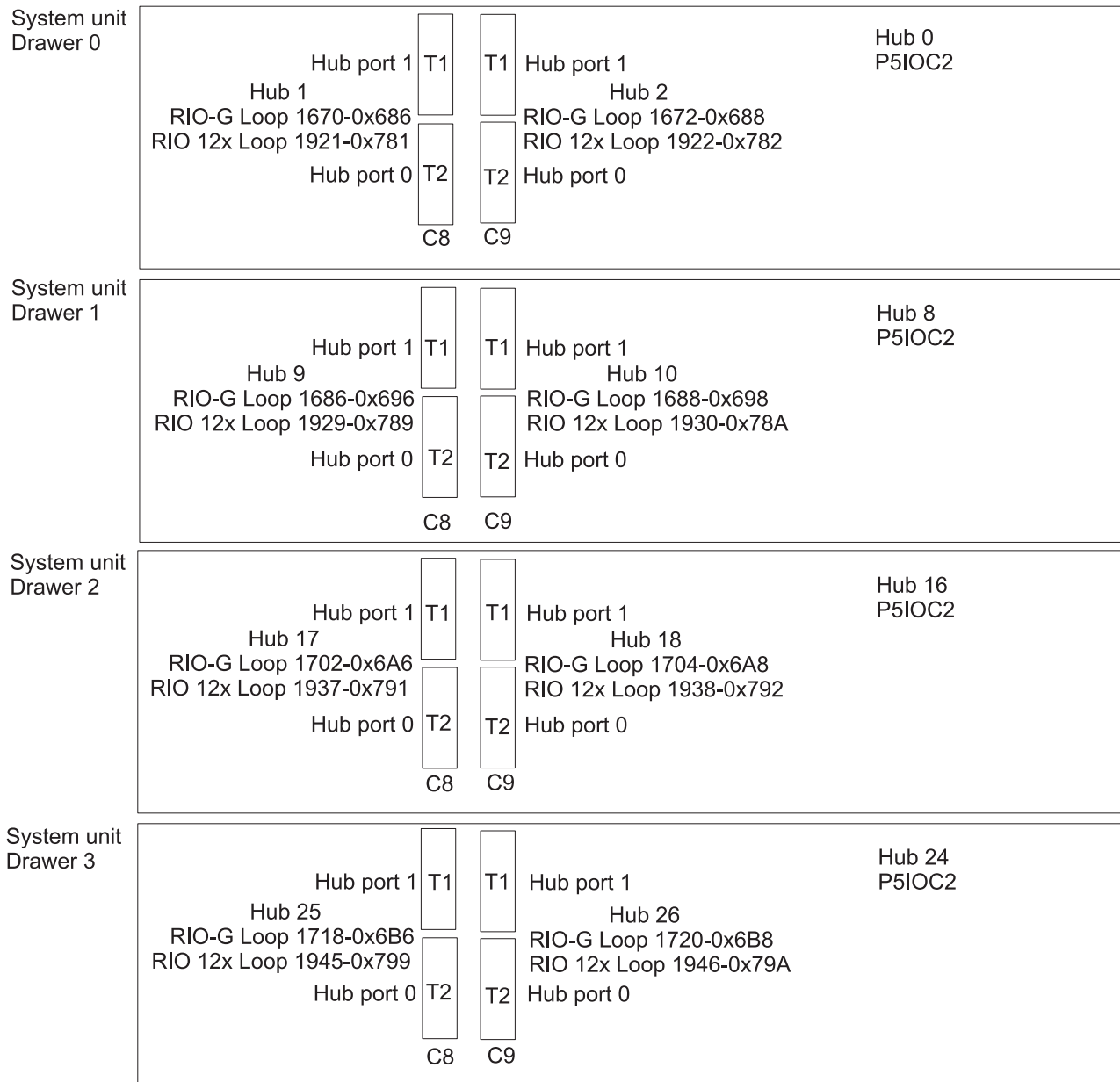

Figure 6. 9406-MMA and 9117-MMA RIO loop diagram

5. Isolate the failing RIO adapter by walking the cabling for the specified RIO loop from the leading port to the trailing port. Do the following:
 - a. Begin walking the cabling by starting at the RIO loop number and RIO port location code that you recorded in step 4.b.
 - b. Starting with 0 (zero) for the first RIO adapter on the loop, follow the loop cabling and count each RIO adapter in the order it is cabled. For example, the first RIO adapter is 0, the next is 1, the next is 2, and so on.
 - c. Continue this process until you count up to the decimal value of the RIO loop position. The RIO adapter that corresponds to the value of the RIO loop position is the failing RIO adapter.

Note: Concurrent maintenance requires that you make a change to the previous procedure for counting the RIO adapters on the loop. If concurrent maintenance was performed to attach one or more additional RIO adapters to this loop and the server has not been IPL'ed after the adapters were

added, then **exclude the added RIO adapters as you make the initial count**. If the RIO loop position exceeds the number of RIO adapters, continue by counting the added RIO adapters in the order they were added to the loop.

- Exchange the failing RIO adapter. To determine the FRU part number and the FRU location, use the following table to find and replace the failing part. **This ends the procedure.**

Table 21. SIIOADP FRU part numbers

CCIN or FFC	Type and model	Part number	Description	Location code
1800	9406-MMA, 9117-MMA	39J0792	RIO-2/HSL-2 adapter	Un-P1-Cx
1802	8203-E4A, 9407-M15, 9408-M25	10N9982	RIO-2/HSL-2 adapter	Un-P1-Cx
1802	8204-E8A, 9409-M50	10N6859	RIO-2/HSL-2 adapter	Un-P1-Cx
2886	5094, 5096, 5294, 5296	39J0669	HSL (optical) I/O bridge adapter	Un-CB1-C10
2887	5094, 5096, 5294, 5296	39J0527	HSL I/O bridge adapter	Un-CB1-C10
28E7	5094, 5096, 5294, 5296	39J0523	HSL-2 I/O bridge adapter	Un-CB1-C10
28FF	5790, 7311-D11	03N5633	RIO/HSL-2 adapter card	Un-P1-C7
2886	0595, 5095, 7311-D20	39J0669	RIO/HSL (optical) adapter card	Un-P1-C05
2887	0595, 5095, 7311-D20	39J0527	RIO/HSL adapter card	Un-P1-C05
28E7	0595, 5095, 7311-D20	39J0523	RIO/HSL-2 adapter card	Un-P1-C05
50A2	5802, 5877	See Finding parts, locations, and addresses.	I/O backplane	Un-P1
50A2	5803, 5873	See Finding parts, locations, and addresses.	I/O backplane	Un-P1, Un-P2
520A	5796, 7314-G30	10N8782	Dual-port 12X adapter	Un-P1-C7
	1519	42R4468	Integrated xSeries ^(R) adapter (IXA)	

SIRGCBL

This symbolic FRU is not supported on the system. Continue with the next FRU in the failing item list.

SIRGCFG

An invalid configuration was detected on an HSL/RIO loop during IPL.

The four rightmost characters of word 4 in the reference code represent the Program Return Code (PRC), which describes the problem detected. The four leftmost digits of word 7 represent the loop number in hexadecimal format. Convert the loop number to decimal format before comparing it to loop numbers shown in serviceable event views and service tools.

To determine the problem, find the PRC in the table below.

Note: The FRU description in the serviceable event view may already contain a message that identifies the problem.

Table 22. Table 1. Correcting an invalid configuration on an HSL/RIO loop

PRC	Problem identified	Corrective action
xxxx 0008	System serial number not set	Set the serial number on the system unit. See "Accessing the Advanced System Management Interface" in the service guide for the system unit. If the problem persists contact your next level of support.
xxxx 3200	Clustered system(s) on loop with SPD migrated tower	Migration towers are not supported; remove them.
xxxx 3201	Clustered systems on multiple HSL/RIO loops	Ensure all clustered systems are on the same HSL/RIO loop.
xxxx 3202	Multiple SPD migrated towers detected	Migration towers are not supported; remove them.
xxxx 3207	SPD migrated tower not on first HSL/RIO loop	Migration towers are not supported; remove them.
xxxx 3212	NIC/RIO controller level does not support OptiConnect	The NIC/RIO controller hardware component does not support HSL OptiConnect. The FRU containing the NIC/RIO controller component must be upgraded to a level that supports HSL OptiConnect. Examine the Service Action Log (SAL) of the system on this loop for the same error. The SAL will call out the correct FRU to replace. Use the service tools and information for that system to correct the problem and close the problem on this system.

This ends the procedure.

SIRSTAT

A status indication for a RIO/HSL loop is identified in the reference code.

Use the table below to determine if the status indication requires a service action. Record the rightmost four characters of word 4 of the reference code. These characters are the program return code (PRC), which indicates the RIO/HSL status. The leftmost four characters of word 7 indicate the RIO/HSL loop number (in hexadecimal format).

Table 23. Table 1. Status indicated by the PRC

PRC	Indicated status
3204	<p>A RIO error was detected, indicating that a RIO link failed.</p> <ol style="list-style-type: none"> 1. To diagnose the error read through the transport manager flight recorder. 2. Check the failing link. If the link shows not to have failed, check the devices connected to either end of the link.

Table 23. Table 1. Status indicated by the PRC (continued)

PRC	Indicated status
3205	<p>During IPL, LIC determined that the loop was not complete.</p> <ul style="list-style-type: none"> • This is expected if there are no I/O units on the loop. • This error can also occur when an I/O unit, shared I/O unit, or another system on the loop did not complete powering on by the time this system's LIC checked the loop for completeness. As a result, you may see this error in the serviceable event view you are working with. • When you find the same reference code logged from the same IPL against the same resource with a PRC of 3206 or 3208, the problem no longer exists. This can happen because the error was recovered when RIO/HSL hardware came on line, was properly configured, or the diagnostic code determined that there was not a problem based on the combination of machine types, features, configuration, and topology. In this case, you may close the problem entry. • In IBM i, this error may also appear in the serviceable event view if any I/O units were removed from the loop without deleting the RIO/HSL I/O bridge resources of those units from Hardware Service Manager (HSM). The service procedure identified with the reference code that sent you here will help you determine if the loop is functioning correctly or if service is required. • This error may also be caused by a problem in a rack, frame, or unit connected to the RIO/HSL loop if the problem prevents the unit from powering on or being detected by LIC. Follow the service procedures for this reference code. When necessary, you may be directed to work on other reference codes before returning to this procedure.
3206	During normal operation an RIO/HSL loop recovered its redundant path. The loop is now complete.
3208	During normal operation an RIO/HSL I/O bridge recovered a failed link on the loop.
3209	See indicated status for PRC 3209 below.
3210	<p>An RIO/HSL link switched to a slower speed. The link is designed to run at a faster speed based on the link's hardware and LIC levels at both ends. If there is a FRU list in the serviceable event view, use it to complete the repair action. If not, perform the following sections of this procedure below:</p> <ol style="list-style-type: none"> 1. Determining the RIO/HSL port label 2. Replacing the link's failing end point FRUs (replace only the "From Frame ID" end point FRU)

Determining the RIO/HSL port label

Retrieve and record the following information:

- **Loop number.** The loop number is displayed in hexadecimal format as the four leftmost digits of word 7 in the reference code. Convert the loop number to decimal format using DSA translation. If the loop is an internal loop on (loops 0680, 0683, 0686, 0689 hexadecimal or 1664, 1667, 1670, 1673 decimal), then record "Internal".
- **Frame ID.** The frame ID is displayed in hexadecimal format as the four leftmost digits of word 5 of the reference code. You must convert the frame ID to decimal format to match what is displayed in user interfaces and problem views. Record both the hexadecimal and decimal formats of the frame ID. If the frame ID is not zero, then translate the frame ID into the correct machine type, model, and serial number by performing the following:
 1. Log on to SST/DST. **Attention:** Do not IPL to DST.
 2. Select Hardware Service Manager.
 3. Select Packaging resources.
 4. Selecting Display details for each unit listed until the frame ID matches the ID you are working with. Once you find the matching frame ID, record the unit's machine type, model, and serial number.

Note: The frame has an ID of 0000 at this point in the procedure. A frame ID of zero is indicating the NIC/RIO controller in a system unit.
- **Port number indicator.** The port number indicator is the four rightmost digits of word 5 of the reference code.

Use the frame ID and port number indicator in the following table to determine the RIO/HSL port label. If you are referred to Converting the loop number to NIC port location labels, the failing item is in a system unit. You will need the RIO/HSL loop number to determine the FRU.

The following tables provide hub, port, and location code information the model MMA. This data is used to determine which RIO loop to use for the B7006981. The asterisk in the "Port indicator number" column indicates the leading port of the port pair.

Table 24. Table 2. Determining which RIO/HSL port label to use on a MMA

Model number	Loop number	CEC	Hub	Port indicator number	Location code
MMA	1668	0	0	0*	"Internal" (Top CEC)
				1	"Internal"
	1669	0	0	2*	P1-T8
				3	P1-T9
	1676	0	4	0*	P1-C7-T2
				1	P1-C7-T1
MMA	1684	1	8	0*	"Internal" (Second down)
				1	"Internal"
	1685	1	8	2*	P1-T8
				3	P1-T9
	1692	1	12	0	P1-C7-T2
				1	P1-C7-T1
MMA	1700	2	16	0*	"Internal" (Third down)
				1	"Internal"
	1701	2	16	2*	P1-T8

Table 24. Table 2. Determining which RIO/HSL port label to use on a MMA (continued)

Model number	Loop number	CEC	Hub	Port indicator number	Location code
				3	P1-T9
	1708	2	20	0	P1-C7-T2
				1	P1-C7-T1
MMA	1716	3	24	0*	"Internal" (Fourth down)
				1	"Internal"
	1717	3	24	2*	P1-T8
				3	P1-T9
	1724	3	28	0	P1-C7-T2
				1	P1-C7-T1

Note:

For MMA, exchange the FRU on the correct unit (primary or secondary) by matching the serial number (if available in the FRU list on the serviceable event view) or by matching the loop number to the correct unit using Converting the loop number to RIO/HSL/12X port location labels.

Determining if the cable is the cause of the problem

If there is a cable attached to the failing port:

- If the cable is optical, it is possible the optical connections need cleaning. You can choose either to clean the cable connections at each end without exchanging the cable, or to exchange the cable. Use symbolic FRU OPT_CLN for information on cleaning the connections.
- If the cable is copper, examine the screws that hold the connector at the end of the cable identified in the reference code or the first cable location listed in the serviceable event view entry. It is possible to get CRC errors when the connector screws are not tight. You can choose to tighten the cable connector screws without exchanging the cable only if they are loose. Otherwise, you must exchange the cable.
- If neither of these actions resolves the problem, replace the cable. Perform isolation procedure RIOIP08 (see the service guide for the system unit on which you are working) to determine the frame ID and RIO/HSL port label of the other end of the cable you will be exchanging (if you do not already know). Does this correct the problem?
 - **Yes: This ends the procedure.**
 - **No:** Continue with replacing the FRUs that the cable is connected to, starting with the FRU listed first.

Replacing the link’s failing end point FRUs

Use the following table to determine the end point FRUs on the "From Frame ID" port. Replace the FRUs one at a time.

If replacing the end point FRUs for the "From Frame ID" port does not resolve the error, use the table below to replace the end point FRUs at the other end of the cable. Perform RIOIP08 (see the system unit’s service guide for the procedure) to determine the system or I/O unit frame ID and RIO/HSL port label of the other end of the cable (if you do not already know).

Table 25. Table 3. End point FRUs

Model	Loop number (hexadecimal / decimal)	End point FRUs
MMA	0680 / 1664	The loop is embedded in the system unit planar. Exchange the system unit planar using symbolic FRU SYSBKPL.
MMA	0681 / 1665	For all port number values, the loop's NIC/RIO controller is embedded in the system unit planar. Exchange the system unit planar using symbolic FRU SYSBKPL.
MMA	0682 / 1666	For all port number values, the loop's NIC/RIO controller is in the NIC/RIO controller card. Exchange the NIC/RIO controller using symbolic FRU SICNTRL.
MMA	0683 / 16670686 / 16700689 / 1673	The loop is embedded in the system unit planar. Exchange the system unit planar using symbolic FRU SYSBKPL. Note: Exchange the FRU on the correct unit (primary or secondary) by matching the serial number (if available in the FRU list on the serviceable event view) or by matching the loop number to the correct unit using Converting the loop number to RIO/HSL/12X port location labels.

This ends the procedure.

SLOTERR

The multi-adapter bridge detected a problem with a card location that it controls.

The problem is in the controls for the card slot. The card location may or may not have an installed card. If there is a card installed in that location, it may be the source of the problem. In some cases, the user interface view of the serviceable event will list more than one card position for this FRU's location. The problem may be with any one of the FRU's in those locations. When there is a list of locations in this FRU's location code, the card locations will be separated by commas. A range of card positions will show the starting card position, a colon, and the ending card position.

Note: Any IOPs plugged into slots owned by a Linux[®] partition will not power on. This error will be logged. Correct the situation by removing the IOP cards.

1. Is there a single card position listed in the serviceable event user interface of an operating system, service processor, or the HMC for this failing item?
 - **No:** Continue with the next step.
 - **Yes:** Go to step 5.
2. Is there a range of card positions (PCI bridge set) listed in the problem view for this failing item?
 - **No:** Continue with the next step.
 - **Yes:** LIC could not identify the slot with the error. Perform MABIP50 to determine the card position with the failure.

This ends the procedure.

3. Record the Direct Select Address (DSA), which is word 7 of the reference code from the problem view display.
4. Examine the multi-adapter bridge function number in the DSA. See DSA translation.
Is the multi-adapter bridge function number less than or equal to 7?
 - **Yes:** Go to procedure MABIP53 to locate the card, and then continue with the next step.
 - **No:** LIC could not identify the slot with the error. Perform MABIP50 to determine the card position with the failure.
This ends the procedure.
5. Does the reference code that sent you here appear more than once, or does another reference code with this symbolic FRU appear from the same IPL and against the same resource?
 - **Yes:** The failure is at the multi-adapter bridge. Do not use this symbolic FRU; instead, go to the next failing item in the list.
This ends the procedure.
 - **No:** Locate the message in the following table to determine the problem and necessary corrective action.

Table 26. Table 1. Card slot errors

Problem or message	Meaning or corrective action
Slot unavailable due to 64-bit card in adjacent slot.	<p>The card location specified in the DSA is unavailable for the card installed there. Do not use that card location.</p> <p>The card location with a multi-adapter bridge function number one less than the multi-adapter bridge function number in the DSA has a 64-bit card installed. The 64-bit card is using the 32-bit PCI bus of the card location specified in the DSA.</p> <p>To determine the multi-adapter bridge function numbers and the card locations they specify, see DSA translation.</p>
LED control failure, do not use slot.	System code has detected a problem with the controls for the LED at the card location specified by the DSA. Do not use that card location.
Power control failure, do not use slot.	System code has detected a problem with the power controls at the card location specified by the DSA. Do not use that card location.
Multi-adapter bridge card slot error, do not use card slot.	System code has detected a problem with the controls at the card location specified by the DSA. Do not use that card location.

This ends the procedure.

SLOTUSE

The card in the given slot is not available for use.

1. Is the SRC B2002250 or B2002300?
 - **No:** Continue with step 3.
 - **Yes:** The first two characters in word 4 of the reference code will identify the platform LIC component that has control of the slot. Continue with the next step.
2. What is the value of the first two characters of word 4 of the reference code?
 - **81:** The component that has control of the slot is concurrent maintenance. The concurrent maintenance procedure must complete before the partition will IPL. **This ends the procedure.**

- **02 or 03:** The component that has control of the slot is HMC service or HMC configuration. Make sure that HMC functions are not using the slot. **This ends the procedure.**
 - **Other:** Contact your next level of support. **This ends the procedure.**
3. Is the SRC B2002475?
 - **No:** Contact your next level of support. **This ends the procedure.**
 - **Yes:** Continue with the next step.
 4. Look in the serviceable event view for part numbers and location codes associated with the card slot.

Note: There will not be a part number if the card slot is empty. If the reference code is on the control panel, look in the FRU callout section of the reference code for the location of the card slot. Check the server to see if a card is physically present in the card slot. Is a card physically present?

 - **No:** Use symbolic FRU LPARCFG to reconfigure the card slot so that it is not a required resource to IPL the partition. **This ends the procedure.**
 - **Yes:** Exchange the failing card. **This ends the procedure.**

SNSDATA

Look here for information about SNSDATA symbolic FRU.

This is a portion of the SCSI sense data associated with the unit reference code (URC); it is not a failing item in and of itself. This data is referenced by certain failure isolation procedures within the All 3995 Publications and Documentation at <http://snjInt02.sanjose.ibm.com/tape/tapetec.nsf/pages/3995pub> or the 3996 Maintenance Information shipped with the 3996 Optical Library.

SPBUS

The path to the service processor might be the failing item.

Look in the serviceable event view. Fix all B700 697x errors that occurred at approximately the same time. One of them will implicate the hardware that communicates with the service processor.

SPNETWK

A connection between an HMC and a service processor has been lost.

The location code will identify the unit to which contact was lost.

1. Is the system receiving power?
 - **No:** Take the necessary action to restore power to the system. **This ends the procedure.**
 - **Yes:** Continue with the next step.
2. Verify the network connection between the service processor and the HMC. See the table below for location information.

FRU name (check in order, one at a time)	Location
8203-E4A, 9407-M15, 9408-M25 Service processor to HMC cable, Ethernet cable	U n-P1-T5
8204-E8A, 9409-M50 Service processor to HMC cable, Ethernet cable	U n-P1-T7
9117-MMA or 9406-MMA Service processor to HMC cable, Ethernet cable	U n-P1-C11-T3

3. Does the problem persist?
 - **No:** **This ends the procedure.**
 - **Yes:** Continue with the next step.

4. Shut down the operating system for the server in preparation to reboot the server. Reapply the power and boot the server. Does the problem persist?
 - **No: This ends the procedure.**
 - **Yes:** Continue with the next step.
5. Use SVCPROC to replace the service processor. If the problem persists, contact your next level of support. **This ends the procedure.**

SPNLCRD

This symbolic FRU is no longer supported.

SRCTB1X

There is a failure detected by the power subsystem.

The complete FRU part number, procedure ID, or symbolic FRU could not be determined by the power subsystem firmware. This FRU in the serviceable event view might have a partial or complete location code that will assist you in the repair action. Go to Reference codes and look up the SRC.

Read the SRC description and perform any actions indicated.

STORIOA

The storage I/O adapter might be failing.

Use the I/O adapter location information in the Service Action Log if it is available. If the location is not available, find the address of the I/O adapter. See The system reference code format description. Use the address to find the location and part number from the table below.

Use the following table to determine the part number for the field replaceable unit (FRU):

CCIN or FFC	Type and model	Part number	Description	Location code
	8203-E4A, 9407-M15, 9408-M25	42R7898	System backplane (embedded SAS controller)	Un-P1
57B8	8203-E4A, 9407-M15, 9408-M25	44V3298	SAS RAID enablement card	Un-P1
	8204-E8A, 9409-M50	10N9369	System backplane (embedded SAS controller)	Un-P1
57B8	8204-E8A, 9409-M50	44V3298	SAS RAID enablement card	Un-P1
	9406-MMA, 9117-MMA	42R7352	I/O backplane (embedded SAS controller)	Un-P1
572A	All	44V3296	PCI-X DDR external dual-4x port SAS adapter	Un-P1-Cx
5703	All	39J5105	Storage IOA	Un-P1-Cx
		42R5070	Cache battery pack for 5703	
571A	All	42R4860	Storage IOA	Un-P1-Cx
571B	All	42R4855	Storage IOA	Un-P1-Cx

		39J5555	Cache battery pack for 571B	
2757	All	39J5581	Storage IOA	Un-P1-Cx
		53P0941	Cache battery pack for 2757	
2780	All	39J5581	Storage IOA	Un-P1-Cx
		39J5554	Cache battery pack for 2780	
571E	All	42R5130	Storage IOA	Un-P1-Cx
574F	All	42R5133	PCI-X DDR auxiliary cache adapter card for 571E	Un-P1-Cx
	All	42R4053	Cable connection to 571E	Un-P1-Cx
		39J5554	Cache battery pack for 574F	
571F	All	42R6578	Combination storage and auxiliary cache (571F, 571B)	Un-P1-Cx
		42R3965	Cache battery pack for 571F	

SVCDOCS

Look here for information about SVCDOCS symbolic FRU.

This symbolic FRU means that the service action is to read the description of the system reference code (SRC) and perform any actions indicated there. If you have already read and performed the actions in the description, then go the next failing item in the failing item list.

If you cannot return to the SRC description, go to Reference codes and look up the SRC.

Read the SRC description and perform any actions indicated.

SVCPROC

The service processor might be failing.

Use the table below to determine the FRU part number for the service processor. Some units have the service processor built into the system backplane.

Note: After you replace the part and before attempting to power up the server, set the configuration ID for the SPCN. Otherwise, the server will not IPL. For information about setting the configuration ID, see PWR1917.

If the server is a multiple-drawer 9406-MMA or 9117-MMA server and the SRC is a B1 xx SRC, use the last byte in word 3 of the primary SRC to determine which service processor card to replace:

- If the last byte is a 10, replace the primary unit's service processor card.
- If the last byte is a 20, replace the secondary unit 1, service processor card.

If you don't have access to word 3 of the primary SRC, you can also determine which service processor card to replace by using either of the following methods:

- If you have access to the Advanced System Management Interface (ASMI), log on and display the details of the service processor error log. Using the Platform Event Log id (shown in the first table of each detail of the log), look at the first byte.
 - If the first byte is a 50, then replace the primary unit service processor.
 - If the first byte is a 51, then replace the secondary unit 1 service processor.
- If you have access to a Hardware Management Console (HMC), log in as PE user and bring up Manage Serviceable Events under the Service Focal Point screen. Display the events for the corresponding service processor system, then double-click the system to see the details. Look at the Field Platform log ID, which contains a decimal value that you need to convert to a hexadecimal value.
 - If the first byte is a 50, then replace the primary unit service processor.
 - If the first byte is a 51, then replace the secondary unit 1 service processor.

Use the following table to determine the part number for the field replaceable unit (FRU):

CCIN or FFC	Type and model	Part number	Description	Location code
	8203-E4A, 9407-M15, 9408-M25	42R7898	System backplane (service processor is part of the system backplane for the 8203-E4A, 9407-M15, 9408-M25)	U n-P1
	8204-E8A, 9409-M50	10N9369	System backplane (service processor is part of the system backplane for the 8204-E8A, 9409-M50)	U n-P1
	9406-MMA, 9117-MMA	10N8752	Service processor card (service interface card)	U n-P1-C11

This ends the procedure.

SYSBKP2

The failing component is the system backplane.

After you have replaced the part, set the enclosure serial number before powering up, otherwise the machine will not IPL. See the system unit service guide for more information regarding setting the enclosure serial number.

Use the table below to find the service information for the specified FRU.

Use the following table to determine the part number for the field replaceable unit (FRU):

CCIN or FFC	Type and model	Part number	Description	Location code
	8203-E4A, 9407-M15, 9408-M25	42R7898	System backplane	U n-P1
	8204-E8A, 9409-M50	10N9369	System backplane	U n-P1
	9406, 9117-MMA	03N6902	System backplane	U n-P2

This ends the procedure.

SYSBKPL

The backplane might be failing.

The failing component is the system backplane (I/O backplane for 9406-MMA or 9117-MMA).

Use the table below to find the service information for the specified FRU.

Note: After you have replaced the part, make sure to set the enclosure serial number before powering up, otherwise the machine will not IPL. For more information, see "Setting the system enclosure type" in the operations guide for the server.

If the server is a multiple-drawer 9406-MMA or 9117-MMA server and the SRC is a B1 xx SRC, use the last byte in word 3 of the primary SRC to determine which backplane to replace:

- If the last byte is a 10, then replace the primary unit, I/O backplane.
- If the last byte is a 20, then replace the secondary unit 1, I/O backplane.

If you don't have access to word 3 of the primary SRC, you can also determine which backplane to replace by using either of the following methods:

- If you have access to the Advanced System Management Interface (ASMI), log on and display the details of the service processor error log. Using the Platform Event Log id (shown in the first table of each detail of the log), look at the first byte.
 - If the first byte is a 50, then replace the primary unit I/O backplane.
 - If the first byte is a 51, then replace the secondary unit 1 I/O backplane.
- If you have access to a Hardware Management Console (HMC), log in as PE user and bring up Manage Serviceable Events under the Service Focal Point screen. Display the events for the corresponding service processor system, then double-click the system to see the details. Look at the Field Platform log ID, which contains a decimal value that you need to convert to a hexadecimal value.
 - If the first byte is a 50, then replace the primary unit I/O backplane.
 - If the first byte is a 51, then replace the secondary unit 1 I/O backplane.

Use the following table to determine the part number for the field replaceable unit (FRU):

CCIN or FFC	Type and model	Part number	Description	Location code
	8203-E4A, 9407-M15, 9408-M25	42R7898	System backplane	U n-P1
	8204-E8A, 9409-M50	10N9369	System backplane	U n-P1
	9406-MMA, 9117-MMA	42R7352	I/O backplane	U n-P1

This ends the procedure.

SYSBP

The backplane might be failing.

Replace the system backplane according to the following table:

Failing MTM	Replace this FRU	Link to locations information
9117-FHA	Un-P1	Part locations and location codes
9125-F2A	BPC B (rear)	Part locations and location codes

SYSNTWK

There has been a network adapter failure on this HMC.

1. Check the amber port LEDs. Are all of the amber LEDs blinking?
 - **Yes:** One of the ports is not properly configured. Go to Configuring the HMC. **This ends the procedure.**
 - **No:** The port with the unlit amber LED is experiencing the problem. Continue with the next step.
2. Ensure that the port is properly defined.
3. Run PC Doctor diagnostics to determine which resource is failing, and then replace that failing resource. See Hardware Management Console models 7042-CR4, 7042-C06, and 7042-C07 service for HMC diagnostic and parts information.

This ends the procedure.

TAPCLN

Clean the tape unit.

TAPCNFG

Look here for information about TAPCNFG symbolic FRU.

One of the following configuration problems was detected:

- Tape and disk devices are attached to an I/O processor or IOA that does not support tape and disk devices at the same time.
- An unsupported device type or model is attached.

Correct the configuration problem before exchanging any parts.

TOD

The battery for the time-of-day battery is low or failing.

See symbolic FRU TOD_BAT.

TOD_BAT

The battery for the time-of-day battery is low or failing.

Use the table below to find the service information for the specified FRU.

For B1xx SRCs:

To determine which Time-of-day (TOD) battery to replace on a 9406-MMA or 9117-MMA, use the last byte in word 3 of the primary SRC.

- If the last byte is a 10, then replace the TOD battery on the primary unit, service processor for a 9406-MMA or 9117-MMA.
- If the last byte is a 20, then replace the TOD battery on the secondary unit 1, service processor for a 9406-MMA or 9117-MMA.
- If the last byte is a 30, use one of the following methods to determine which TOD battery you need to replace:
 - If you have access to the Advanced System Management Interface (ASMI), log on and display the details of the service processor error log. Using the Platform Event Log id (shown in the first table of each detail of the log), look at the first byte.
 -

- If the first byte is a 50, then replace the TOD battery on the primary unit service processor for a 9406-MMA or 9117-MMA.
- If the first byte is a 51, then replace the TOD battery on the secondary unit 1 service processor for a 9406-MMA or 9117-MMA.
- If you have access to a Hardware Management Console (HMC), log in as PE user and bring up Manage Serviceable Events under the Service Focal Point screen. Display the events for the corresponding service processor system, then double-click the system to see the details. Look at the Field Platform log ID, which contains a decimal value that you need to convert to a hexadecimal value.
-
- If the first byte of the hexadecimal value is a 50, then replace the TOD battery on the primary unit service processor for a 9406-MMA or 9117-MMA.
- If the first byte of the hexadecimal value is a 51, then replace the TOD battery on the secondary unit 1 service processor for a 9406-MMA or 9117-MMA.

Use the following table to determine the part number for the field replaceable unit (FRU):

CCIN or FFC	Type and model	Part number	Description	Location code
	8203-E4A, 9407-M15, 9408-M25	44V4359	System unit, Time-of-day (TOD) battery	U n-P1-E1
	8204-E8A, 9409-M50	16G8095	system unit, Time-of-day (TOD) battery	U n-P1-E1
	9406-MMA or 9117-MMA	16G8095	Primary unit, Time-of-day (TOD) battery	U n-P1-C11-E1
	9406-MMA or 9117-MMA	16G8095	Secondary unit 1, Time-of-day (TOD) battery	U n-P1-C11-E1

This ends the procedure.

TOPORT

The RIO/HSL/12X adapter or controller on one end of the link might be the failing item.

If you were sent to this procedure as a result of a B700 6985 SRC, and this is the only FRU in the FRU list, then the following conditions have occurred:

- The system cannot see any I/O expansion units on a RIO/HSL/12X loop
- At least one cable is attached to a port on that loop

In this case, go to Reference codes and look up SRC B700 6985 and work from the full FRU list provided there.

Note: The other end of the link might be given in the symbolic FRU FRPORT.

To find the failing RIO/HSL/12X adapter, do the following:

1. Record the bus number (BBBB) in word 7 of the reference code (see Analyzing a RIO/HSL/12X or PCI bus reference code).

Note: If the previous link does not function in your environment, search for the topic in the service guide for the server on which you are working.

2. Use one of the following procedures to find the failing RIO/HSL/12X adapter:

- Finding the failing RIO/HSL/12X adapter using IBM i
- Finding the failing RIO/HSL/12X adapter using AIX or Linux
- Finding the failing RIO/HSL/12X adapter using the HMC

Finding the failing RIO/HSL adapter using IBM i

1. Sign on to SST or DST if you have not already done so.
2. Select **Start a service tool** → **Hardware service manager** → **Logical hardware resources** → **High-speed link (HSL) resources**.
3. Select **Include non-reporting resources** then click **Display detail** for the RIO/HSL/12X loop that you want to examine. The loop number is the number from word 7 of the reference code above.
4. The display that appears shows the port status of the Network Interface Controller (NIC) for the loop that you selected. Record the resource name, type-model, and serial number.
5. If the status of the "Leading port to next resource" is **operational**, then select **Follow Leading Port**. Repeat this action until the status changes to **failed**. Does the resource name ever match the one recorded in the previous step?
 - **Yes:** You have traveled around the loop and did not find a failed link. **This ends the procedure.**
 - **No:** Continue with the next step.
6. When the status is **failed**, you have found the **from** port. Select **Follow Leading Port** one more time, which moves to the **to** port.
7. Record the following information of this resource:
 - a. Resource name, card type and model, and part number
 - b. Link status of each port (make sure to note if a port is designated as internal)
8. Select **Cancel** to return to the Work with High-speed link (HSL) resources display.
9. For the loop with the failure, select **Resources associated with loop**.
10. For the RIO/HSL/12X I/O bridge with the resource name that you recorded, select **Associated packaging resources**.
11. Select **Display detail** and record the location for the first failing resource.
12. Replace this FRU, use the following table to determine the failing FRU part number. **This ends the procedure.**

CCIN or FFC	Type and model	Part number	Description	Location code
2886	5094, 5096	39J0669	RIO/HSL optical bus adapter	Un-CB1-C10
2887	5094, 5096	39J0527	RIO/HSL2 adapter	Un-CB1-C10
28E7	5094, 5096	39J0523	RIO/HSL2 adapter	Un-CB1-C10
28FF	5790	03N5633	RIO/HSL2 adapter	Un-P1-C7
28E7	0595, 5095	39J0523	RIO/HSL2 adapter	Un-P1-C5
520A	5796	10N8782	Dual-port 12X adapter	Un-P1-C7
	8203-E4A, 9407-M15, 9408-M25	10N9982	RIO-2/HSL-2 adapter	Un-P1-Cx
	8203-E4A, 9407-M15, 9408-M25	44V4645	GX DUAL-PORT 12X HCA	Un-P1-Cx
	8204-E8A, 9409-M50	10N6859	RIO-2/HSL-2 adapter	Un-P1-Cx
	8204-E8A, 9409-M50	10N9529	GX DUAL-PORT 12X HCA	Un-P1-Cx
1800	9406-MMA, 9117-MMA	39J0792	RIO/HSL-2 adapter	Un-P1-Cx

CCIN or FFC	Type and model	Part number	Description	Location code
1802	9406-MMA, 9117-MMA	42R6849	GX DUAL-PORT 12X HCA	Un-P1-Cx

This ends the procedure.

Finding the failing RIO/HSL/12X adapter using AIX or Linux

1. Determine on which RIO/HSL/12X loop the failing adapter is located. Refer to Converting the loop number to NIC port location labels.

Note: If the previous link does not function in your environment, search for the topic in the service guide for the server on which you are working.

2. Identify each unit in the loop by following the cable.
3. Power down the system and remove all expansion units in the loop that starts and ends at the ports given in the previous step.
4. Power on the system to partition standby and check for the same SRC that sent you here. Did the SRC reoccur?
 - **No:** Power down the system and add the next unit in the original loop. Repeat this step.
 - **Yes:** If there are no expansion units in the loop, replace the controller on the system unit. Otherwise, the RIO/HSL/12X adapter in the last I/O unit added is possibly the failing item. Use the following table to determine the part number for the field replaceable unit (FRU):

CCIN or FFC	Type and model	Part number	Description	Location code
28FF	5790, 7311-D11	03N5633	RIO/HSL2 adapter	Un-P1-C7
28E7	0595, 5095, 7311-D20	39J0523	RIO/HSL2 adapter	Un-P1-C5
520A	5796, 7314-G30	10N8782	Dual-port 12X adapter	Un-P1-C7
	8203-E4A, 9407-M15, 9408-M25	10N9982	RIO-2/HSL-2 adapter	Un-P1-Cx
	8204-E8A, 9409-M50	44V4645	GX DUAL-PORT 12X HCA	Un-P1-Cx
	8204-E8A, 9409-M50	10N6859	RIO-2/HSL-2 adapter	Un-P1-Cx
	8204-E8A, 9409-M50	10N9529	GX DUAL-PORT 12X HCA	Un-P1-Cx
1800	9406-MMA, 9117-MMA	39J0792	RIO/HSL-2 adapter	Un-P1-Cx
1802	9406-MMA, 9117-MMA	42R6849	GX DUAL-PORT 12X HCA	Un-P1-Cx

Finding the failing RIO/HSL/12X adapter using the HMC

1. From the HMC, expand **Systems Management** then expand **Servers**. Select the server on which you are working then expand **Hardware Information**, then click **View RIO-12X Topology**.
2. In the Current Topology area, scroll down until you find data for the RIO/HSL/12X loop number with which you are working.
3. Each line in that RIO/HSL/12X loop represents a RIO/HSL/12X adapter or controller. Find the first one with a trailing port status of **failed**. Replace the failing adapter or controller. Use the following table to determine the part number for the field replaceable unit (FRU):

Table 27. Part number and FRU listing

CCIN or FFC	Type and model	Part number	Description	Location code
28FF	5790, 7311-D11	03N5633	RIO/HSL2 adapter	Un-P1-C7
28E7	0595, 5095, 7311-D20	39J0523	RIO/HSL2 adapter	Un-P1-C5
520A	5796, 7314-G30	10N8782	Dual-port 12X adapter	Un-P1-C7
	8203-E4A, 9407-M15, 9408-M25	10N9982	RIO-2/HSL-2 adapter	Un-P1-Cx
	8203-E4A, 9407-M15, 9408-M25	44V4645	GX DUAL-PORT 12X HCA	Un-P1-Cx
	8204-E8A, 9409-M50	10N6859	RIO-2/HSL-2 adapter	Un-P1-Cx
	8204-E8A, 9409-M50	10N9529	GX DUAL-PORT 12X HCA	Un-P1-Cx
1800	9406-MMA, 9117-MMA	39J0792	RIO/HSL-2 adapter	Un-P1-Cx
1802	9406-MMA, 9117-MMA	42R6849	GX DUAL-PORT 12X HCA	Un-P1-Cx

This ends the procedure.

TWRBKPL

The failing item is the tower card in an I/O unit.

- Are you working from the serviceable event view and a card location is listed with this failing item?
 - Yes:** Then the listed card location is where the error is located. Continue with the next step.
 - No:** Record the bus number value, BBBB, in word 7 of the reference code (see DSA translation). Search for the bus number in the HMC's or operating system's resource and configuration interfaces or the System Configuration Listing to determine which unit contains the failing item. Continue with the next step.
- The failing item is built into the I/O backplane of the I/O unit. Use the following table to determine the part number for the field replaceable unit (FRU):

CCIN or FFC	Type and model	Part number	Description	Location code
	5790, 7311-D11	80P6626	I/O backplane	Un-P1
28BE	0595, 5095, 7311-D20	39J0515	I/O backplane	Un-P1
	5796, 7314-G30	See Finding parts, locations, and addresses.	I/O backplane	Un-P1
	5094	39J3058	I/O backplane	Un-CB1

This ends the procedure.

TWRCARD

An SPCN card might be failing.

The SPCN card can be on either an adapter style card or integrated on the system backplane or an I/O backplane in an attached I/O expansion unit.

Perform the following to service this FRU.

1. Is the system reference code (SRC) 1xxx00AD?

- **No:** Go to step 3.
- **Yes:** The 1xxx00AD SRC might be caused by the service processor being intentionally reset. An intentional reset is caused by an action such as a pin hole reset, ASMI menu selection, or part replacement. An intentional reset requires no service action. If your system produced the 1xxx00AD SRC and an intentional reset was not the cause, use the following table to determine the part number of the field replaceable unit (FRU):

CCIN or FFC	Type and model	Part number	Description	Location code
	9117-FHA	60H3873	Primary system controller	Un-P1-C2 or Un-P1-C5
6319	9125-F2A	45D2193	I/O assembly without PCI capability	Un-P1
6399	9125-F2A	45D2188	I/O assembly with PCI and I/O Drawer Attachment Capability	Un-P1

2. Is the system reference code (SRC) 1xxx5000 or 1xxx5001?

- **No:** Continue to the next step.
- **Yes:**
 - For SRC 1xxx5000 do one of the following:
 - For model 8203-E4A, 9407-M15, 9408-M25, replace the system backplane, use the following table to determine the part number for the field replaceable unit (FRU):

CCIN or FFC	Type and model	Part number	Description	Location code
	8203-E4A, 9407-M15, 9408-M25	42R7898	System backplane	Un-P1

- For model 8204-E8A, 9409-M50, replace the system backplane, use the following table to determine the part number for the field replaceable unit (FRU):

CCIN or FFC	Type and model	Part number	Description	Location code
	8204-E8A, 9409-M50	10N9369	System backplane	Un-P1

- For model 9406-MMA or 9117-MMA, replace the service processor card in the top drawer of a multiple-drawer system (unit 0), use the following table to determine the part number for the field replaceable unit (FRU):

CCIN or FFC	Type and model	Part number	Description	Location code
	9406-MMA, 9117-MMA	10N8752	Service processor card	Un-P1-C11

- For SRC 1xxx5001:
 - For model 9406-MMA or 9117-MMA, replace the service processor card in the second drawer of a multiple-drawer system (unit 1), use the following table to determine the part number for the field replaceable unit (FRU):

CCIN or FFC	Type and model	Part number	Description	Location code
	9406-MMA, 9117-MMA	10N8752	Service processor card	Un-P1-C11

3. Verify that all cables are seated correctly.

4. Examine the location code of this FRU in the serviceable event view you are working with to determine the unit's type and model. Is the failing SPCN component in the system unit?

- **No:** Go to step 6.
- **Yes:**
 - For model 8203-E4A, 9407-M15, 9408-M25, the SPCN component is part of the system backplane, replace the system backplane. Use the following table to determine the part number for the field replaceable unit (FRU):

CCIN or FFC	Type and model	Part number	Description	Location code
	8203-E4A, 9407-M15, 9408-M25	42R7898	System backplane	Un-P1

- For model 8204-E8A, 9409-M50, the SPCN component is part of the system backplane, replace the system backplane. Use the following table to determine the part number for the field replaceable unit (FRU):

CCIN or FFC	Type and model	Part number	Description	Location code
	8204-E8A, 9409-M50	10N9369	System backplane	Un-P1

- For model 9406-MMA or 9117-MMA, replace the service processor card in the top drawer of a multiple-drawer system (unit 0), use the following table to determine the part number for the field replaceable unit (FRU):

CCIN or FFC	Type and model	Part number	Description	Location code
	9406-MMA, 9117-MMA	10N8752	Service processor card	Un-P1-C11

5. Does the reference code still occur?

- **No: This ends the procedure.**
- **Yes:**
 - For model 8203-E4A, 8204-E8A, 9407-M15, 9408-M25, or 9409-M50, contact your next level of support. **This ends the procedure.**
 - On a model 9406-MMA or 9117-MMA, replace the I/O backplane, use the following table to determine the part number for the field replaceable unit (FRU):

CCIN or FFC	Type and model	Part number	Description	Location code
	9406-MMA, 9117-MMA	42R7352	I/O backplane	Un-P1

6. The failing SPCN component is in an I/O expansion drawer. Use the following table to determine the part number for the field replaceable unit (FRU):

CCIN or FFC	Type and model	Part number	Description	Location code
	5790, 7311-D11	80P6626	The SPCN components are part of the I/O backplane, replace the I/O backplane	Un-P1
	0595, 5095, 7311-D20	39J0515	The SPCN components are part of the I/O backplane, replace the I/O backplane	Un-P1

	5796, 7314-G30	41L6022	SPCN card	Un-P1-C8
	5094	39J3058	The SPCN components are part of the I/O backplane, replace the I/O backplane	Un-CB1
	1519	42R4468	Integrated xSeries adapter	
	5802	See Finding parts, locations, and addresses.	The SPCN components are part of the EMC card. Replace the EMC card.	Un-P2

This ends the procedure.

TWRPLNR

The failing component is in the PCI I/O backplane of an I/O unit.

- Are you working from the serviceable event view and a card location is listed with this failing item, or do you already know the unit or feature type where the failure is?
 - Yes:** The listed card location is where the error is located. Continue with the next step.
 - No:** Record the bus number value, BBBB, in word 7 of the reference code. Word 7 of the reference code allows you to determine the correct bus number, bus type, multi-adapter bridge number, multi-adapter bridge function number, and logical card number from the Direct Select Address (DSA), see DSA translation. Continue with the next step.
- Use the following table to determine the part number for the field replaceable unit (FRU):

CCIN or FFC	Type and model	Part number	Description	Location code
	5790, 7311-D11	80P6626	I/O backplane	Un-P1
	0595, 5095, 7311-D20	39J0515	I/O backplane	Un-P1
	5796, 7314-G30	See Finding parts, locations, and addresses.	I/O backplane	Un-P1
	5094, 5294, 5096, 5296	39J3058	I/O backplane	Un-CB1
	5802	See Finding parts, locations, and addresses.	I/O planar	Un-P1

This ends the procedure.

UC235

The problem may be that the card (a resource) was removed from the card enclosure without updating the system configuration records.

Note: If the system has OptiConnect, verify that the remote system was powered on at the time of the failure.

To update the system configuration records select **Hardware System Manager** → **Logical Hardware Resources** → **System Bus Resources** → **Non-reporting Resources** → **Remove**.

This ends the procedure.

UC236

The problem might be that the card (a resource) is not correctly plugged into the card enclosure.

Use the location information associated with this failing component in the Service Action Log entry and verify that the card is installed properly.

UG3LB

Communications problem analysis has completed successfully.

The results have been recorded in the problem log. You can keep this information for future reference, or you can delete the problem record using the delete problem (DLTPRB) command. The problem record can also be deleted by selecting option 4 from the work with problem display for the problem.

If you choose to keep the problem information, you can run the procedure again by selecting option 8 to work with the problem.

This ends the procedure.

UG3AS

An error has been detected in the licensed internal code.

Contact your next level of support for possible corrective actions.

UJ0E2

The problem has been isolated to the remote data terminal equipment.

Local System

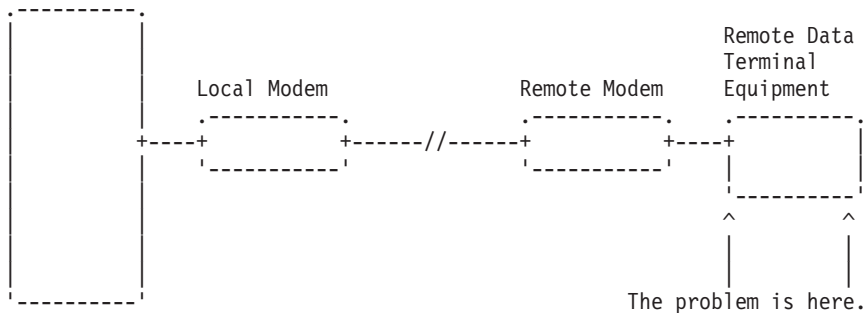

UJ0E3

The problem has been isolated to the local modem or the hardware that links to the remote end.

Local System

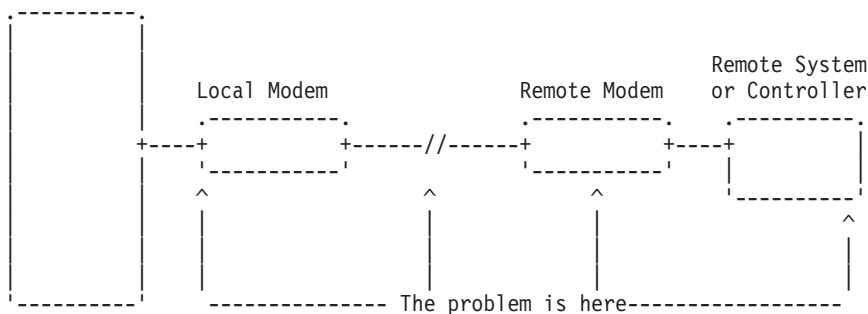

UJ0E6

The problem has been isolated to the remote modem, or the remote system or controller.

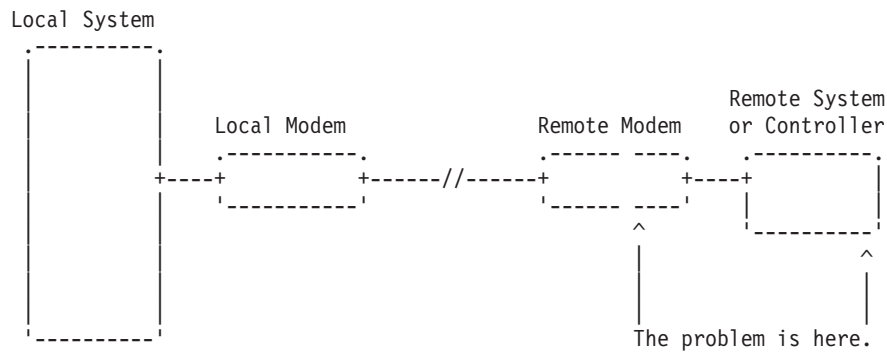

UJ0E7

The problem has been isolated to the telephone line equipment that links the local and the remote equipment.

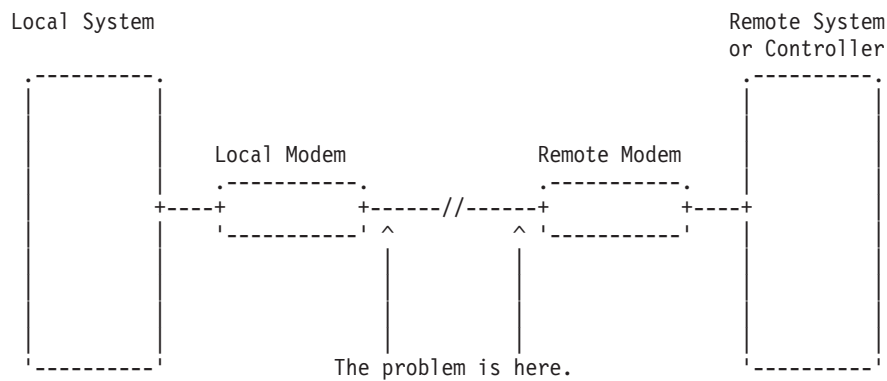

UJ0E9

The problem has been isolated to the X.25 network.

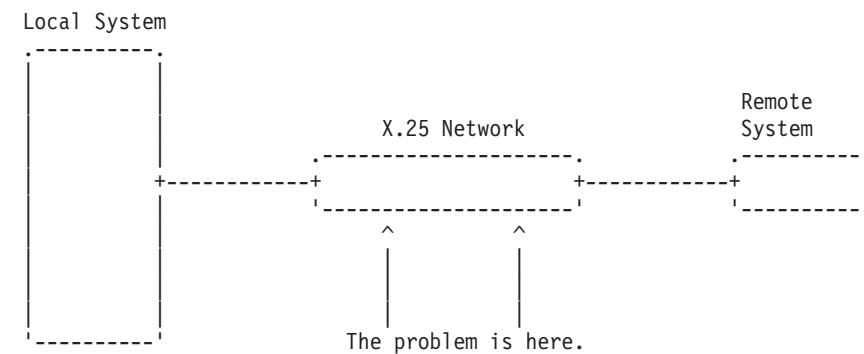

UJ6P3

An error occurred in the Facsimile Support/400 Licensed Program.

Please contact your next level of support for possible corrective actions.

Find additional information on Facsimile Support for OS/400® in the Application System Facsimile Support for OS/400 User's Guide.

UJ9GC

The configuration for the wireless network has been identified as a cause of the problem.

The following parameters must be the same for the entire network:

- Frequency
- Data rate
- Radio system identifier

The configuration for one or more of the following will need to be changed:

- IBM i line description
- Access points
- Remote devices

UJA32

The communication line or the automatic call unit is already being used.

Perform the following:

1. Use the documentation that came with your automatic call unit to verify that the unit is configured correctly.
2. Make sure that the telephone line attached to your automatic call unit is not being used by another job.

This ends the procedure.

UJA33

The problem can be caused by too many active lines using the same input/output processor (IOP) card or by setting the line speed too high.

Perform the following to find which active lines use the same IOP, and to correct the problem:

1. Vary off the failing line using the VRYCFG command.
2. Vary the line on again, with the reset option of the VRYCFG command set to **Yes**. The active lines using that IOP will be displayed with their line speeds.
3. Determine if there are too many lines using the IOP, or if the line speeds are too high.
4. Correct the configuration as needed.

This ends the procedure.

UJA34

A configuration parameter might be incorrect.

To determine the configuration parameter that was identified as a possible problem, search for the error in the Service Action Log and display the failing item information for the error. The failing item description associated with this symbolic FRU identifies the parameter that may be the problem.

The line configuration parameter that was identified as a possible problem can be changed by using the WRKLIND command. Determine if the suspected configuration parameter is wrong and change if necessary. For more information about commands related to communications, see the "CL command finder" document in the iSeries Information Center at <http://publib.boulder.ibm.com/infocenter/iseres/v5r4/index.jsp?topic=/clfinder/finder.htm>.

Some software problems can be temporarily solved by changing the configuration parameter, even if the original value was correct. Report this problem to your service representative if you use this temporary change.

UJA35

A configuration parameter might be incorrect.

To determine the configuration parameter that was identified as a possible problem, search for the error in the Service Action Log and display the failing item information for the error. The failing item description associated with this symbolic FRU identifies the parameter that may be the problem.

The configuration parameter that was identified as a possible problem can be verified by displaying the synchronous data link control (SDLC) controller description with the DSPCTLD command.

The controller description was created by the CRTCTLAPPC, CRTCTLFNC, CRTCTLHOST, or CRTCTLRWS command. You may need to review the appropriate command information to determine if the configuration parameter is wrong.

For more information about commands related to communications, see the "CL command finder" document in the iSeries Information Center at <http://publib.boulder.ibm.com/infocenter/iseres/v5r4/index.jsp?topic=/clfinder/finder.htm>.

Some software problems can be temporarily solved by changing the configuration parameter, even if the original value was correct. Report this problem to your service representative if you use this temporary change.

UJA36

A configuration parameter might be incorrect.

To determine the configuration parameter that was identified as a possible problem, search for the error in the Service Action Log and display the failing item information for the error. The failing item description associated with this symbolic FRU identifies the parameter that may be the problem.

The configuration parameter that was identified as a possible problem can be verified by displaying the X.25 line description with the DSPLIND command.

The line description was created by the CRTLINX25 command. You may need to review the appropriate command information to determine if the configuration parameter is wrong.

For more information about commands related to communications, see the "CL command finder" document in the iSeries Information Center at <http://publib.boulder.ibm.com/infocenter/iseres/v5r4/index.jsp?topic=/clfinder/finder.htm>.

Some software problems can be temporarily solved by changing the configuration parameter, even if the original value was correct. Report this problem to your service representative if you use this temporary change.

UJB35

A configuration parameter might be incorrect.

To determine the configuration parameter that was identified as a possible problem, search for the error in the Service Action Log and display the failing item information for the error. The failing item description associated with this symbolic FRU identifies the parameter that may be the problem.

The configuration parameter that was identified as a possible problem can be verified by displaying the binary synchronous line description with the DSPLIND command.

The line description was created by the CRTLINBSC command. You may need to review the appropriate command information to determine if the configuration parameter is wrong.

For more information about commands related to communications, see the "CL command finder" document in the iSeries Information Center at <http://publib.boulder.ibm.com/infocenter/iseres/v5r4/index.jsp?topic=/clfinder/finder.htm>.

Some software problems can be temporarily solved by changing the configuration parameter, even if the original value was correct. Report this problem to your service representative if you use this temporary change.

UJB36

A configuration parameter might be incorrect.

To determine the configuration parameter that was identified as a possible problem, search for the error in the Service Action Log and display the failing item information for the error. The failing item description associated with this symbolic FRU identifies the parameter that may be the problem.

The configuration parameter that was identified as a possible problem can be verified by displaying the binary synchronous control unit description with the DSPCTLD command.

The controller description was created by the CRTCTLBSC command. You may need to review the appropriate command information to determine if the configuration parameter is wrong.

For more information about commands related to communications, see the "CL command finder" document in the iSeries Information Center at <http://publib.boulder.ibm.com/infocenter/iseres/v5r4/index.jsp?topic=/clfinder/finder.htm>.

Some software problems can be temporarily solved by changing the configuration parameter, even if the original value was correct. Report this problem to your service representative if you use this temporary change.

UJB37

A configuration problem occurred.

The problem might be caused by too many jobs running at the same time.

To display all active jobs, and the system resources being used by the jobs, use the display active job command (WRKACTJOB).

To display how the system is being used and how the system memory is allocated, use the display system status command (WRKSYSSTS).

You may need to cancel some jobs or wait until some jobs complete before you run your communications job.

This ends the procedure.

UJC35

A configuration parameter might be incorrect.

To determine the configuration parameter that was identified as a possible problem, search for the error in the Service Action Log and display the failing item information for the error. The failing item description associated with this symbolic FRU identifies the parameter that may be the problem.

The configuration parameter that was identified as a possible problem can be verified by displaying the IDLC line description with the DSPLINID command.

The line description was created by the CRTLINASC command. You may need to review the CRTLINASC command information to determine if the configuration parameter is wrong.

Information about commands related to communications can be found in the following manuals:

- CL Programming, SC41-5721-03
- Communications Configuration, SC41-5401-00

Some software problems can be temporarily solved by changing the configuration parameter, even if the original value was correct. Report this problem to your service representative if you see this temporary change.

UJC36

A configuration parameter might be incorrect.

To determine the configuration parameter that was identified as a possible problem, search for the error in the Service Action Log and display the failing item information for the error. The failing item description associated with this symbolic FRU identifies the parameter that may be the problem.

The configuration parameter that was identified as a possible problem can be verified by displaying the asynchronous control unit description with the DSPCTLD command.

The control unit description was created by the CRTCTLASC command. You may need to review the CRTCTLASC command information to determine if the suspected configuration parameter is wrong.

Information about commands related to communications can be found in the following manuals:

- CL Programming, SC41-5721-03
- Communications Configuration, SC41-5401-00

Some software problems can be temporarily solved by changing the configuration parameter, even if the original value was correct. Report this problem to your service representative if you see this temporary change.

UJC37

A configuration problem occurred.

Verify that the configuration parameters for your asynchronous equipment are correct by doing the following:

- Display the line description with the DSPLIND command (created by the CRTLINASC command).
- Display the controller description with the DSPCTLD command (created by the CRTCTLASC command).
- Display the remote device description with the DSPDEVVD command (created by the CRTDEVASC command).

Some software problems can be temporarily solved by changing the configuration parameter, even if the original value was correct.

Report this problem to your service representative if you use this temporary change.

This ends the procedure.

UJC38

The communications line or the automatic call unit is already being used.

Do the following:

- Use the documentation that came with your automatic call unit to verify that the unit is configured correctly.
- Make sure that the telephone line attached to your automatic call unit is not being used by another job.

This ends the procedure.

UJE31

There might be a problem with the Token-Ring Network Manager program.

Contact the token-ring administrator responsible for your network.

UJE32

There might be a problem with the Token-Ring Network Management function.

Contact the token-ring administrator responsible for your network.

UJE33

The token-ring adapter returned status information because it has received a beacon frame from the token-ring network.

The line is still operational; however, if this problem occurs often it could be because of electrical noise on the network. To learn more about electrical requirements and noise problem considerations, refer to Site and hardware planning.

UJE34

The error message might have been logged from a temporary error that is not caused by equipment failure.

This type of error message sometimes contains information about system performance. See the original system message for cause and recovery information about the error.

UJE35

A configuration parameter might be incorrect.

To determine the configuration parameter that was identified as a possible problem, search for the error in the Service Action Log and display the failing item information for the error. The failing item description associated with this symbolic FRU identifies the parameter that may be the problem.

The configuration parameter that was identified as a possible problem can be verified by displaying the local area network line description with the DSPLIND command.

The line description was created by the CRTLINTRN, CRTLINETH, or CRTLINDDI command. You might need to review the appropriate command information to determine if the configuration parameter is wrong.

For more information about commands related to communications, see the "CL command finder" document in the iSeries Information Center at <http://publib.boulder.ibm.com/infocenter/iseres/v5r4/index.jsp?topic=/clfinder/finder.htm>.

Some software problems can be temporarily resolved by changing the configuration parameter, even if the original value was correct. Report this problem to your service representative if you use this temporary change.

UJE36

A configuration parameter may be incorrect.

To determine the configuration parameter that was identified as a possible problem, search for the error in the Service Action Log and display the failing item information for the error. The failing item description associated with this symbolic FRU identifies the parameter that may be the problem.

The configuration parameter that was identified as a possible problem can be verified by displaying the local area network control unit description with the DSPCTLD command.

The controller description was created by the CRTCTLAPPC, CRTCTLHOST, or CRTCLRWS command. You may need to review the appropriate command information to determine if the configuration parameter is wrong.

For more information about commands related to communications, see the "CL command finder" document in the iSeries Information Center at <http://publib.boulder.ibm.com/infocenter/iseres/v5r4/index.jsp?topic=/clfinder/finder.htm>.

Some software problems can be temporarily solved by changing the configuration parameter, even if the original value was correct. Report this problem to your service representative if you use this temporary change.

UJE37

The problem might be at the remote site.

Perform the following:

1. Ask the remote site operator to verify the following:
 - The remote equipment is powered on and ready.
 - The configuration values are correct.
 - The local area network cables are securely connected and are not damaged.
2. If the problem continues, run all available diagnostic tests on the remote equipment and perform the repair action specified.

This ends the procedure.

UJE38

Too many jobs are running that use the communications controller.

Before you can run your communications job, you must do one or more of the following:

- End any diagnostic program that may be running, such as the Communications Trace Program.
- Vary off a line that is using the controller.
- Lower the speed of a line that uses the controller.

Perform the following to find which lines are using the controller:

1. Vary off the failing line using the VRYCFG command.
2. Vary the line on again, with the reset option of the VRYCFG command set to **Yes**. The names of the lines using the controller will be displayed.

This ends the procedure.

UJE39

The problem might be at the remote site.

Perform the following:

1. Ask the remote site operator to verify the following:
 - The remote equipment is powered on and ready.
 - The configuration values are correct.
2. If the problem continues, run all available diagnostic tests on the remote equipment and perform the repair action specified.

This ends the procedure.

UJE40

The problem might be at the remote site or on the network media.

Perform the following:

1. Ask the remote site operator to verify the following:
 - The remote equipment is powered on and ready.
 - The configuration values are correct.
 - The local area network cables are securely connected and are not damaged.
2. If the problem continues, run all available diagnostic tests on the remote equipment and perform the repair action specified.

This ends the procedure.

UJJ35

A configuration parameter might be incorrect.

To determine the configuration parameter that was identified as a possible problem, search for the error in the Service Action Log and display the failing item information for the error. The failing item description associated with this symbolic FRU identifies the parameter that may be the problem.

The configuration parameter that was identified as a possible problem can be verified by displaying the X.25 line description with the DSPLIND command.

The line description was created by the CRTLINX25 command. You may need to review the appropriate command information to determine if the configuration parameter is wrong.

For more information about commands related to communications, see the "CL command finder" document in the iSeries Information Center at <http://publib.boulder.ibm.com/infocenter/iseres/v5r4/index.jsp?topic=/clfinder/finder.htm>.

Some software problems can be temporarily solved by changing the configuration parameter, even if the original value was correct. Report this problem to your service representative if you use this temporary change.

UJJ36

A configuration parameter might be incorrect.

To determine the configuration parameter that was identified as a possible problem, search for the error in the Service Action Log and display the failing item information for the error. The failing item description associated with this symbolic FRU identifies the parameter that may be the problem.

The configuration parameter that was identified as a possible problem can be verified by displaying the X.25 control unit description with the DSPCTLD command.

The controller description was created by the CRTCTLAPPC, CRTCTLFNC, CRTCTLHOST, CRTCTLRWS, or CRTCTLASC command. You may need to review the appropriate command information to determine if the configuration parameter is wrong.

For more information about commands related to communications, see the "CL command finder" document in the iSeries Information Center at <http://publib.boulder.ibm.com/infocenter/iseriess/v5r4/index.jsp?topic=/clfinder/finder.htm>.

Some software problems can be temporarily solved by changing the configuration parameter, even if the original value was correct. Report this problem to your service representative if you use this temporary change.

UJJ37

The error message might have been logged from a temporary error that is not caused by equipment failure.

This type of error message sometimes contains information about system performance. See the original system message for cause and recovery information about the error.

UJJ38

A user specified X.25 facility, such as packet size, window size, reverse charging, or closed user group, might not have been correctly assigned.

UJJ39

Look here for information about UJJ39 symbolic FRU.

Refer to the "Configure your iSeries server for communications" document in the IBM eServer™ iSeries Information Center at <http://publib.boulder.ibm.com/infocenter/iseriess/v5r4/index.jsp?topic=/rzajt/rzajtrzajtconas400.htm>

UJP37

A configuration problem occurred.

The problem might be caused by one of the following:

- Too many active lines are using the same I/O processor (IOP).
- The line speeds are set too high.

To find the lines using the same IOP, do the following:

- Vary off the failing line (VRYCFG command).
- Vary the line back on, with the reset option of the VRYCFG command set to Yes.
- The active lines using that IOP will be displayed with their line speeds. Determine if there are too many lines using the IOP, or if the line speeds are set too high. Correct the configuration as needed.

This ends the procedure.

ULNZ3

The problem might be a communications line problem.

When a workstation is attached to the system through modems, it may fail or lose communication with the system for various lengths of time. This is due to a communications line problem. Refer to the modem service information to determine how to test the modems and verify that the communications line between the modems is working correctly.

ULNZ4

Independent workstation and SDLC support.

The system considers an independent workstation to be an attached remote system when it is attached using PC Support asynchronous communications on an ASCII workstation controller.

Perform the following:

- See the *ASCII Work Station Reference*, SA41-3130-00 information for instructions on how to verify that the remote system (independent workstation) that is attached to the failing port is a supported device.
- See the device hardware maintenance and service information for instructions on how to verify that the device is working correctly.

UNM31

A configuration parameter might be incorrect.

To determine the configuration parameter that was identified as a possible problem, search for the error in the Service Action Log and display the failing item information for the error. The failing item description associated with this symbolic FRU identifies the parameter that may be the problem.

The configuration parameter that was identified as a possible problem can be verified by displaying the ISDN network interface description with the DSPNWIISDN command.

The line description was created by the CRTNWIISDN command. You may need to review the appropriate command information to determine if the configuration parameter is wrong.

For more information about commands related to communications, see the "CL command finder" document in the iSeries™ Information Center at <http://publib.boulder.ibm.com/infocenter/iseriess/v5r4/index.jsp?topic=/clfinder/finder.htm>.

Some software problems can be temporarily solved by changing the configuration parameter, even if the original value was correct. Report this problem to your service representative if you use this temporary change.

UNM32

The licensed internal code of the communications I/O card cannot obtain a necessary resource because of a heavy workload.

This can be caused by too many configured stations, too many users, maximum inbound or outbound data sizes, as well as other considerations.

Try to reduce the total workload on the communications I/O controller card by performing one of the following:

- Change the communications configuration
- Vary off any unused lines
- End any service functions that are not needed

UNM35

There could be a problem at the remote U interface, between the NT1 node and the Integrated Services Digital Network (ISDN).

This interface is a 2-wire connection between the NT1 node and the ISDN. Contact your ISDN provider and have them verify the proper operation of the interface.

UNM36

There might be a problem in the Integrated Services Digital Network (ISDN).

Contact your ISDN service provider and report the problem

UNM38

The required program temporary fix (PTF) is not installed.

To use the specified network type, you must first install a PTF. If the PTF has not been previously installed, install it and try the operation again.

UNP20

The internal code of the I/O card that detected the error might be defective.

Perform the following:

1. Replace the suspected card.
2. If the failure occurs again, contact your next level of support and report the problem.

This ends the procedure.

UNU01

Electrical noise in the local environment can cause performance degradation or loss of an ISDN communications link.

Motors, electrical devices, power cables, communications cables, radio transmitters, and magnetic devices can cause noise or electrical interference.

Perform the following:

1. Inspect ISDN cables or wiring located near a source of possible noise or electrical interference.
2. Inspect ISDN cables for damage, incorrect connections, or loose connections.
3. Consult your local ISDN network provider or service representative for assistance in correcting the problem.

This ends the procedure.

UNU02

The problem may be at the remote location.

Perform the following:

1. Have the remote site operator verify that the remote equipment is powered on and ready, and that the remote configuration values are correct and compatible with the local configuration.
2. If the problem continues, determine if data is being transferred over the remote ISDN interface. This can be done by either using a communications trace (STRSST), or attaching a protocol analyzer to the line.

- If a line trace reveals that no data is being transferred, then run hardware and diagnostic tests on the remote equipment.
- If data is crossing the ISDN interface, analyze the failing protocol procedures to determine which configuration parameters to change. Consult your service representative for help with this analysis.

This ends the procedure.

UNU31

A configuration parameter might be incorrect.

To determine the configuration parameter that was identified as a possible problem, search for the error in the service action log and display the failing item information for the error. The failing item description associated with this symbolic FRU identifies the parameter that might be the problem.

The configuration parameter that was identified as a possible problem can be verified by displaying the IDLC line description with the DSPLINIDLC command.

The line description was created by the CRTLINIDLC command. You may need to review the appropriate command information to determine if the configuration parameter is incorrect.

Some software problems can be temporarily solved by changing the configuration parameter, even if the original value was correct. Report this problem to your service representative if you use this temporary change.

UNU32

A configuration parameter might be incorrect.

To determine the configuration parameter that was identified as a possible problem, search for the error in the service action log and display the failing item information for the error. The failing item description associated with this symbolic FRU identifies the parameter that might be the problem.

The configuration parameter that was identified as a possible problem can be verified by displaying the IDLC controller description with the DSPCTLD command.

The controller description was created by the CRTCTLHOST, CRTCTLAPPC, or CRTCTLRWS command. You might need to review the appropriate command information to determine if the configuration parameter is incorrect.

Some software problems can be temporarily solved by changing the configuration parameter, even if the original value was correct. Report this problem to your service representative if you use this temporary change.

UPLF1

The system might not have been able to complete the Advanced Peer-to-Peer Networking (APPN) session initiation due to the number of jobs that were active when the timeout occurred.

The timeout condition could have been caused by a system performance problem. System performance could be impacted by the capacity of the system. System performance can also be impacted by processing requests from other systems in the network.

UPLF2

A request was sent to one or more systems in the network, but the local system did not receive the response in the allotted time.

The timeout might be caused by a network performance problem. Possible causes for network performance problems are:

- Network congestion
- Capacity of some systems in the network exceeded
- Software problem in one or more systems might have caused the requests to be lost

Contact the remote operators to determine if any software problems related to Advanced Peer-to-Peer Networking (APPN) have been reported. Take any steps necessary to correct the problem.

This ends the procedure.

UPLF3

A timeout condition might have occurred because the system was not able to activate a switched link to a remote control point.

A possible cause is that a message was issued to the QSYSOPR message queue that pertains to the controller description selected by Advanced Peer-to-Peer Networking (APPN). However, no response to the message was provided.

This timeout also might have occurred because a previous session initiation request for the same local location, remote location, and mode name failed during the switched link activation.

This ends the procedure.

UPLF4

The session initiation attempt might have failed because of a route selection problem.

Advanced Peer-to-Peer Networking (APPN) transmission groups and nodes with acceptable class-of-service characteristics might need to be activated in the intermediate routing portion of the network.

If the operating systems involved are IBM i operating systems, this might require varying on line descriptions and controller descriptions in the network. It might also indicate that one or more communication lines between some of the systems in the network are not operating.

This ends the procedure.

UPLF5

The session initiation attempt might have failed because of a route selection problem.

The available nodes and transmission groups in the Advanced Peer-to-Peer Networking (APPN) topology might be unacceptable for the class-of-service being requested. A possible solution is to select a different class-of-service for the session initiation request so that the existing network topology is considered acceptable.

The class-of-service used for the session initiation requests in an IBM i operating system is specified in the mode description. Have the user select a mode description that specifies an acceptable class-of-service, or change the mode description so that it specifies an acceptable class-of-service.

This ends the procedure.

UPLF6

The session initiation attempt might have failed because of a route selection problem.

Transmission groups and nodes with acceptable class-of-service characteristics might need to be defined in the intermediate routing portion of the network. It is suggested that the correct documentation be referenced to determine how to define nodes and transmission groups with acceptable class-of-service characteristics.

This ends the procedure.

UPSUNIT

The uninterruptible power supply (UPS) might be the failing component.

Perform the following:

1. Is the problem that the system has a UPS reference code, but the UPS does not have a fault code?
 - **Yes:** Continue with the next step.
 - **No:** Go to step 3.
2. Remove the UPS signal cable from the system connector. Does the system report a UPS reference code now?
 - **No:** Continue with the next step.
 - **Yes:** Replace the following, one at a time, until the problem is resolved, use the following table to determine the part number for the field replaceable unit (FRU): **CCIN or FCC Type and model**

CCIN or FCC	Type and model	Part number	Description	Location code
	8203-E4A	42R7898	System backplane	Un-P1
	8204-E8A	10N9369	System backplane	Un-P1
	9406-MMA, 9117-MMA	10N8752	Service processor card (SPCN function for the system unit)	Un-P1-C11
	UPS		Remote power controller (RPC)	

This ends the procedure.

3. Perform the following:
 - a. Verify the UPS signal cable, between the UPS and the system, is connected and seated properly.
 - b. Have the customer call the UPS provider for service if a problem is found.
 - c. Call service support if the problem is not resolved after the UPS is verified as working correctly.

This ends the procedure.

USER

A system operator error or user error occurred.

See the system operator information.

UX201

The printer definition table might be causing the problem.

See the original system message for cause and recovery information about the error.

UX202

A problem was detected while downloading a device Licensed Internal Code change to the device.

See the original system message for cause and recovery information about the error.

UY1Z1

There might be a cable problem.

Problems that are associated with noise might cause a workstation to fail or lose communication with the system for various lengths of time. A motor or any device that is a source of electrical radiation might cause noise or electrical interference. The following are common causes for noise problems:

- The cables are located near a source of electrical interference.
- The cables are loose, damaged, or not correctly connected.

UY1Z2

This error might occur if you attempted to activate more workstations than the amount allowed.

Perform one of the following to correct the problem:

- Turn off the power for the workstation that caused the error, or connect the workstation to a different controller.
- Turn off the power for a different workstation that is connected to the same workstation controller.

See the local workstation diagrams for the physical location of workstations.

This ends the procedure.

UY1Z3

This error might be caused by a workstation that is connected to the port.

1. Perform the following:
 - a. Turn off the power for one workstation on the port
 - b. Check if the other workstations operate correctly.
 - c. Repeat this for each workstation on the port.
 - d. The workstation that causes the problem is the one that is turned off when the others are working correctly.
 - e. If you did not find the problem, continue with the next step.
2. Perform the following:
 - a. Turn off the power for all workstations on the port.
 - b. Turn on one workstation to check if it works when all other workstations are turned off.
 - c. Repeat this for each workstation on the port. The workstation that causes the problem is the one that works when all other workstations are turned off.

This ends the procedure.

UY1Z4

An error occurred with the pass-through command between the workstation controller and the workstation.

A failure in the Licensed Internal Code in either the workstation or the workstation controller causes this type of error.

UY1Z5

The communication between the workstation controller and a workstation was interrupted during an active session.

Possible causes include:

- The power for the workstation was turned off and then turned on.
- A temporary loss of power to the workstation occurred.

VPDPART

Look here for information about VPDPART symbolic FRU.

1. Is the reference code 1xxx8402?

- **No:** Continue with the next step.
- **Yes:** Prior to exchanging any parts, verify that the processors cards are installed. If you are in test mode and have removed all of the processor cards, disregard this reference code. Otherwise, verify that the processor cards are installed correctly. If the processor cards are installed correctly, exchange the service processor card (in certain systems, the service processor function is built into the system backplane). Use the following table to determine the part number for the field replaceable unit (FRU):

Note: If the reference code is associated with an I/O expansion unit, replace the I/O backplane in the I/O expansion unit.

CCIN or FFC	Type and model	Part number	Description	Location code
	8203-E4A, 9407-M15, 9408-M25	42R7898	System backplane	Un-P1
28A3	8204-E8A, 9409-M50	10N9369	System backplane	Un-P1
	9406-MMA, 9117-MMA	10N8752	Service processor card	Un-P1-C11
	5790, 7311-D11	80P6626	I/O backplane	Un-P1
	9119-FHA	60H3873	Primary system controller card. (This card might also be referred to as an FSP card.)	Un-P1-C2 Un-P1-C5
6319	9125-F2A	45D2193	I/O assembly without PCI capability	Un-P1
6399	9125-F2A	45D2188	I/O assembly with PCI and I/O Drawer Attachment Capability	
	0595, 5095, 7311-D20	39J0515	I/O backplane	Un-P1
	5796, 7314-G30	See Finding parts, locations, and addresses.	I/O backplane	Un-P1
	5094	39J3058	I/O backplane	Un-CB1

This ends the procedure.

2. Is the reference code 1xxx8404, 1xxx8405, or 1xxx8406?

- **No:** Continue with the next step.
- **Yes:** Use the following table to find the correct action to take.

Reference code	Action
1xxx8404	Processor card mismatch. Exchange processor card 2 in the primary drawer (top drawer). See Table 28 on page 314 to determine the part number for the field replaceable unit.

Reference code	Action
1xxx8405	Processor card mismatch. Exchange processor card 1 in a secondary unit. See Table 28 on page 314 to determine the part number for the field replaceable unit.
1xxx8406	Processor card mismatch. Exchange processor card 2 in a secondary unit. See Table 28 on page 314 to determine the part number for the field replaceable unit.

This ends the procedure.

3. Is the reference code 1xxx8409?
 - **No:** Continue with the next step.
 - **Yes:** No processor cards are installed. If you are in test mode and have removed all of the processor cards, disregard this reference code. Otherwise, correct the processor cards:
 - If a 9119-FHA processor book reported this SRC, replace the processor book. **This ends the procedure.**
 - If a 9125-F2A node reported this SRC, replace the processor board, Un-P2. If that does not fix the problem, replace the I/O unit, Un-P1. **This ends the procedure.**
 - For all other models, If the processor cards are installed correctly, exchange all processor cards, use the table of processor card FRU part numbers at the end of this page to determine the part number for the field replaceable unit. **This ends the procedure.**
4. Is the failing system a node in a 9125-F2A?
 - **NO:** Continue with the next step.
 - **YES:** Is the reference code 1xxx8410, 1xxx8420, or 1xxx8470?
 - **NO:** Continue with the next step.
 - **YES:** Replace the processor board, Un-P2, in the 9125-F2A node. This ends the procedure.
5. Is the failing system a processor book in a 9119-FHA?
 - **NO:** Continue with the next step.
 - **YES :** Go to step 13 below.
6. Is the reference code 1xxx8413, 1xxx8414, 1xxx8415, or 1xxx8416?
 - **No:** Continue with the next step.
 - **Yes:** Use the reference code in the following table to find the FRU.

Reference code	Action
1xxx8413	Exchange processor card 1. See Table 28 on page 314 to determine the part number for the field replaceable unit.
1xxx8414	Exchange processor card 2. See Table 28 on page 314 to determine the part number for the field replaceable unit.
1xxx8415	Exchange processor card 3. See Table 28 on page 314 to determine the part number for the field replaceable unit.
1xxx8416	Exchange processor card 4. See Table 28 on page 314 to determine the part number for the field replaceable unit.

This ends the procedure.

7. Is the reference code 1xxx8423 or 1xxx8424?
 - **No:** Continue with the next step.

- **Yes:** Use the reference code in the following table to find the FRU part number.

Reference code	Action
1xxx8423	Exchange processor 1. See Table 28 on page 314 to determine the part number for the field replaceable unit.
1xxx8424	Exchange processor 2. See Table 28 on page 314 to determine the part number for the field replaceable unit.

If this replacement does not fix the problem, replace the system or I/O backplane. Use the following table to determine the part number for the field replaceable unit (FRU):

CCIN or FFC	Type and model	Part number	Description	Location code
	8203-E4A, 9407-M15, 9408-M25	42R7898	System backplane	Un-P1
28A3	8204-E8A, 9409-M50	10N9369	System backplane	Un-P1
	9406-MMA, 9117-MMA	42R7352	I/O backplane	Un-P1

- Is the reference code 1xxx911C?
 - **No:** Continue with the next step.
 - **Yes:** Two of the drawers in the multiple-drawer server have the same VPD information. Reset the system unique identifier in one of the drawers to resolve the problem. **This ends the procedure.**
- Is the reference code 1xxx84A1?
 - **No:** Continue with the next step.
 - **Yes:** The wrong regulator backplane (system processor backplane) is installed or the VPD is not correct. Replace the system backplane.

Use the following table to determine the part number for the field replaceable unit (FRU)

CCIN or FFC	Type and model	Part number	Description	Location code
	8234-EMA, 9406-MMA, 9117-MMA	03N6902	System backplane	Un-P2

This ends the procedure.

- Is the reference code 1xxx84A2?
 - **No:** Continue with the next step.
 - **Yes:** The system backplane in the failing drawer is not the same part number as the system backplane in the primary drawer (top drawer). Replace the system backplane.

Use the following table to determine the part number for the field replaceable unit (FRU):

CCIN or FFC	Type and model	Part number	Description	Location code
	9406-MMA, 9117-MMA	03N6902	System backplane	Un-P2

This ends the procedure.

- Is the reference code 1xxx84A3?
 - **No:** Continue with the next step.
 - **Yes:** The wrong service processor card is installed or the VPD is not correct. Replace the service processor card in the failing drawer.

Use the following table to determine the part number for the field replaceable unit (FRU):

CCIN or FFC	Type and model	Part number	Description	Location code
-------------	----------------	-------------	-------------	---------------

	9406-MMA, 9117-MMA	10N8752	Service processor assembly	Un-P1-C11
--	-----------------------	---------	-------------------------------	-----------

This ends the procedure.

12. Is the reference code 1xxx84A4?

- **No:** Return to Starting a service call and look for a 1xxxyyyy SRC. Follow the actions for that SRC. This ends the procedure.
- **Yes:** The service processor card in the failing drawer is not the same part number as the service processor card in the primary drawer (top drawer). Replace the service processor card in the failing drawer with a service processor card that has the same FRU part number as the service processor card in the primary drawer (top drawer). Use the following table to determine the part number for the field replaceable unit (FRU):

CCIN or FFC	Type and model	Part number	Description	Location code
	9406-MMA, 9117-MMA	10N8752	Service processor assembly	Un-P1-C11

This ends the procedure.

13. Do the last four characters of the SRC have the format 84x0, where x is not equal to 0?

- **YES:** Replace node book Un-P9. **This ends the procedure.**
- **NO:** Continue to the next step.

14. Do the last four characters of the SRC have the format 84x1?

- **YES:** Replace node book Un-P5. **This ends the procedure.**
- **NO:** Continue to the next step.

15. Do the last four characters of the SRC have the format 84x2?

- **YES:** Replace node book Un-P6. **This ends the procedure.**
- **NO:** Continue to the next step.

16. Do the last four characters of the SRC have the format 84x3?

- **YES:** Replace node book Un-P2. **This ends the procedure.**
- **NO:** Continue to the next step.

17. Do the last four characters of the SRC have the format 84x4?

- **YES:** Replace node book Un-P7. **This ends the procedure.**
- **NO:** Continue to the next step.

18. Do the last four characters of the SRC have the format 84x5?

- **YES:** Replace node book Un-P8. **This ends the procedure.**
- **NO:** Continue to the next step.

19. Do the last four characters of the SRC have the format 84x6?

- **YES:** Replace node book Un-P3. **This ends the procedure.**
- **NO:** Continue to the next step.

20. Do the last four characters of the SRC have the format 84x7?

- **YES:** Replace node book Un-P4. **This ends the procedure.**
- **NO:** Continue to the next step.

21. Is the reference code 1xxx1507, 1xxx1517, or 1xxx6000?

- **YES:** Replace the midplane at location Un-P5 in the 5802 expansion unit. **This ends the procedure.**
- **NO:** Continue to the next step.

22. Is the reference code 1xxx6001?

- **YES:** Replace the SAS conduit at location Un-P4 in the 5802 expansion unit. **This ends the procedure.**
 - **NO:** Continue to the next step.
23. Is the reference code 1xxx6002?
- **YES:** Replace the DASD backplane at location Un-P3 in the 5802 expansion unit. **This ends the procedure.**
 - **NO:** Continue to the next step.
24. Is the reference code 1xxx6004?
- **YES:** Replace the I/O planar at location Un-P1 in the 5802 expansion unit. **This ends the procedure.**
 - **NO:** Continue to the next step.
25. Is the reference code 1xxx6009?
- **YES:** Replace port card 1 at location Un-P3-C1 in the 5802 expansion unit. **This ends the procedure.**
 - **NO:** Continue to the next step.
26. Is the reference code 1xxx600A?
- **YES:** Replace port card 2 at location Un-P3-C2 in the 5802 expansion unit. **This ends the procedure.**
 - **NO:** Continue to the next step.
27. Is the reference code 1xxx600B?
- **YES:** Replace port card 3 at location Un-P3-C3 in the 5802 expansion unit. **This ends the procedure.**
 - **NO:** Continue to the next step.
28. Is the reference code 1xxx600C?
- **YES:** Replace port card 4 at location Un-P3-C4 in the 5802 expansion unit. **This ends the procedure.**
 - **NO:** Return to Starting a service call and look for a 1xxxyyyy SRC. Follow the actions for that SRC. **This ends the procedure.**

Processor card FRU table

Use the following table to determine the part number for the field replaceable unit (FRU) as directed from previous procedures. The processor cards shown can be installed any any of the processor card slots:

Table 28. Processor card FRU table

CCIN or FFC	Type and model	Part number	Description	Location code
53E1	8204-E8A, 9409-M50	10N9377	4.2 GHz POWER6, 2 Core Processor Card	Un-P1-Cx
53E2	8204-E8A, 9409-M50	10N9380	4.7 GHz POWER6, 2 Core Processor Card	Un-P1-Cx
	9406-MMA, 9117-MMA	10N9146	3.5 GHz POWER6, 2 Core Processor Card	Un-P2-Cx
	9406-MMA, 9117-MMA	10N9144	4.2 GHz POWER6, 2 Core Processor Card	Un-P2-Cx
	9406-MMA, 9117-MMA	10N9139	4.7 GHz POWER6, 2 Core Processor Card	Un-P2-Cx

VRMOD

The system detected a voltage problem.

Perform the following to service this FRU:

1. Power off the system.
2. Unplug the AC.
3. Reseat the VRMs. Refer to Part locations and location codes for voltage regulator modules. Does that resolve the problem?
 - **Yes: This ends the procedure.**
 - **No:** Continue with the next step.
4. Replace the VRMs. Use the following table to determine the part number for the field replaceable unit (FRU):

CCIN or FFC	Type and model	Part number	Description	Location code
	8203-E4A	44V3845	Voltage regulators for processor 1	Un-P1-C13
	8203-E4A	44V3841	Voltage regulator for processor 1	Un-P1-C18
	8203-E4A	44V3845	Voltage regulators for processor 2	Un-P1-C19
	8203-E4A	44V3841	Voltage regulator for processor 2	Un-P1-C20
	8204-E8A		Voltage regulator assembly	Un-P1-C13-C10 through Un-P1-C16-C10
	8204-E8A		Voltage regulator assembly	Un-P1-C13-C5
	9406-MMA, 9117-MMA	42R7459	Voltage regulator assembly	Un-P2-C3
	9406-MMA, 9117-MMA	42R7459	Voltage regulator assembly	Un-P2-C4
	9406-MMA, 9117-MMA	42R7459	Voltage regulator assembly	Un-P2-C5

This ends the procedure.

Appendix. Notices

This information was developed for products and services offered in the U.S.A.

The manufacturer may not offer the products, services, or features discussed in this document in other countries. Consult the manufacturer's representative for information on the products and services currently available in your area. Any reference to the manufacturer's product, program, or service is not intended to state or imply that only that product, program, or service may be used. Any functionally equivalent product, program, or service that does not infringe any intellectual property right of the manufacturer may be used instead. However, it is the user's responsibility to evaluate and verify the operation of any product, program, or service.

The manufacturer may have patents or pending patent applications covering subject matter described in this document. The furnishing of this document does not grant you any license to these patents. You can send license inquiries, in writing, to the manufacturer.

The following paragraph does not apply to the United Kingdom or any other country where such provisions are inconsistent with local law: THIS INFORMATION IS PROVIDED "AS IS" WITHOUT WARRANTY OF ANY KIND, EITHER EXPRESS OR IMPLIED, INCLUDING, BUT NOT LIMITED TO, THE IMPLIED WARRANTIES OF NON-INFRINGEMENT, MERCHANTABILITY OR FITNESS FOR A PARTICULAR PURPOSE. Some states do not allow disclaimer of express or implied warranties in certain transactions, therefore, this statement may not apply to you.

This information could include technical inaccuracies or typographical errors. Changes are periodically made to the information herein; these changes will be incorporated in new editions of the publication. The manufacturer may make improvements and/or changes in the product(s) and/or the program(s) described in this publication at any time without notice.

Any references in this information to Web sites not owned by the manufacturer are provided for convenience only and do not in any manner serve as an endorsement of those Web sites. The materials at those Web sites are not part of the materials for this product and use of those Web sites is at your own risk.

The manufacturer may use or distribute any of the information you supply in any way it believes appropriate without incurring any obligation to you.

Any performance data contained herein was determined in a controlled environment. Therefore, the results obtained in other operating environments may vary significantly. Some measurements may have been made on development-level systems and there is no guarantee that these measurements will be the same on generally available systems. Furthermore, some measurements may have been estimated through extrapolation. Actual results may vary. Users of this document should verify the applicable data for their specific environment.

Information concerning products not produced by this manufacturer was obtained from the suppliers of those products, their published announcements or other publicly available sources. This manufacturer has not tested those products and cannot confirm the accuracy of performance, compatibility or any other claims related to products not produced by this manufacturer. Questions on the capabilities of products not produced by this manufacturer should be addressed to the suppliers of those products.

All statements regarding the manufacturer's future direction or intent are subject to change or withdrawal without notice, and represent goals and objectives only.

The manufacturer's prices shown are the manufacturer's suggested retail prices, are current and are subject to change without notice. Dealer prices may vary.

This information is for planning purposes only. The information herein is subject to change before the products described become available.

This information contains examples of data and reports used in daily business operations. To illustrate them as completely as possible, the examples include the names of individuals, companies, brands, and products. All of these names are fictitious and any similarity to the names and addresses used by an actual business enterprise is entirely coincidental.

If you are viewing this information in softcopy, the photographs and color illustrations may not appear.

The drawings and specifications contained herein shall not be reproduced in whole or in part without the written permission of the manufacturer.

The manufacturer has prepared this information for use with the specific machines indicated. The manufacturer makes no representations that it is suitable for any other purpose.

The manufacturer's computer systems contain mechanisms designed to reduce the possibility of undetected data corruption or loss. This risk, however, cannot be eliminated. Users who experience unplanned outages, system failures, power fluctuations or outages, or component failures must verify the accuracy of operations performed and data saved or transmitted by the system at or near the time of the outage or failure. In addition, users must establish procedures to ensure that there is independent data verification before relying on such data in sensitive or critical operations. Users should periodically check the manufacturer's support websites for updated information and fixes applicable to the system and related software.

Trademarks

IBM, the IBM logo, and ibm.com are trademarks or registered trademarks of International Business Machines Corp., registered in many jurisdictions worldwide. Other product and service names might be trademarks of IBM or other companies. A current list of IBM trademarks is available on the Web at Copyright and trademark information at www.ibm.com/legal/copytrade.shtml.

Intel, Intel logo, Intel Inside, Intel Inside logo, Intel Centrino, Intel Centrino logo, Celeron, Intel Xeon, Intel SpeedStep, Itanium, and Pentium are trademarks or registered trademarks of Intel Corporation or its subsidiaries in the United States and other countries.

Linux is a registered trademark of Linus Torvalds in the United States, other countries, or both.

Microsoft, Windows, Windows NT, and the Windows logo are trademarks of Microsoft Corporation in the United States, other countries, or both.

Red Hat, the Red Hat "Shadow Man" logo, and all Red Hat-based trademarks and logos are trademarks or registered trademarks of Red Hat, Inc., in the United States and other countries.

Other company, product, or service names may be trademarks or service marks of others.

Electronic emission notices

Class A Notices

The following Class A statements apply to the IBM servers that contain the POWER6 processor.

Federal Communications Commission (FCC) statement

Note: This equipment has been tested and found to comply with the limits for a Class A digital device, pursuant to Part 15 of the FCC Rules. These limits are designed to provide reasonable protection against harmful interference when the equipment is operated in a commercial environment. This equipment generates, uses, and can radiate radio frequency energy and, if not installed and used in accordance with the instruction manual, may cause harmful interference to radio communications. Operation of this equipment in a residential area is likely to cause harmful interference, in which case the user will be required to correct the interference at his own expense.

Properly shielded and grounded cables and connectors must be used in order to meet FCC emission limits. IBM is not responsible for any radio or television interference caused by using other than recommended cables and connectors or by unauthorized changes or modifications to this equipment. Unauthorized changes or modifications could void the user's authority to operate the equipment.

This device complies with Part 15 of the FCC rules. Operation is subject to the following two conditions: (1) this device may not cause harmful interference, and (2) this device must accept any interference received, including interference that may cause undesired operation.

Industry Canada Compliance Statement

This Class A digital apparatus complies with Canadian ICES-003.

Avis de conformité à la réglementation d'Industrie Canada

Cet appareil numérique de la classe A respecte est conforme à la norme NMB-003 du Canada.

European Community Compliance Statement

This product is in conformity with the protection requirements of EU Council Directive 2004/108/EC on the approximation of the laws of the Member States relating to electromagnetic compatibility. IBM cannot accept responsibility for any failure to satisfy the protection requirements resulting from a non-recommended modification of the product, including the fitting of non-IBM option cards.

This product has been tested and found to comply with the limits for Class A Information Technology Equipment according to European Standard EN 55022. The limits for Class A equipment were derived for commercial and industrial environments to provide reasonable protection against interference with licensed communication equipment.

European Community contact:
IBM Technical Regulations
Pascalstr. 100, Stuttgart, Germany 70569
Tele: 0049 (0)711 785 1176
Fax: 0049 (0)711 785 1283
E-mail: tjahn@de.ibm.com

Warning: This is a Class A product. In a domestic environment, this product may cause radio interference, in which case the user may be required to take adequate measures.

VCCI Statement - Japan

この装置は、情報処理装置等電波障害自主規制協議会（VCCI）の基準に基づくクラスA情報技術装置です。この装置を家庭環境で使用すると電波妨害を引き起こすことがあります。この場合には使用者が適切な対策を講ずるよう要求されることがあります。

The following is a summary of the VCCI Japanese statement in the box above.

This product is a Class A Information Technology Equipment and conforms to the standards set by the Voluntary Control Council for Interference by Information Technology Equipment (VCCI). In a domestic environment, this product may cause radio interference, in which case the user may be required to take adequate measures.

Electromagnetic Interference (EMI) Statement - People's Republic of China

声 明

此为A级产品,在生活环境中,该产品可能会造成无线电干扰。在这种情况下,可能需要用户对其干扰采取切实可行的措施。

Declaration: This is a Class A product. In a domestic environment this product may cause radio interference in which case the user may need to perform practical action.

Electromagnetic Interference (EMI) Statement - Taiwan

警告使用者：

這是甲類的資訊產品，在居住的環境中使用時，可能會造成射頻干擾，在這種情況下，使用者會被要求採取某些適當的對策。

The following is a summary of the EMI Taiwan statement above.

Warning: This is a Class A product. In a domestic environment this product may cause radio interference in which case the user will be required to take adequate measures.

IBM Taiwan Contact Information:

台灣IBM 產品服務聯絡方式：
台灣國際商業機器股份有限公司
台北市松仁路7號3樓
電話：0800-016-888

Electromagnetic Interference (EMI) Statement - Korea

이 기기는 업무용으로 전자파적합등록을 한 기기이오니 판매자 또는 사용자는 이점을 주의하시기 바라며, 만약 잘못 판매 또는 구입하였을 때에는 가정용으로 교환하시기 바랍니다.

Please note that this equipment has obtained EMC registration for commercial use. In the event that it has been mistakenly sold or purchased, please exchange it for equipment certified for home use.

Germany Compliance Statement

Deutschsprachiger EU Hinweis: Hinweis für Geräte der Klasse A EU-Richtlinie zur Elektromagnetischen Verträglichkeit

Dieses Produkt entspricht den Schutzanforderungen der EU-Richtlinie 2004/108/EG zur Angleichung der Rechtsvorschriften über die elektromagnetische Verträglichkeit in den EU-Mitgliedsstaaten und hält die Grenzwerte der EN 55022 Klasse A ein.

Um dieses sicherzustellen, sind die Geräte wie in den Handbüchern beschrieben zu installieren und zu betreiben. Des Weiteren dürfen auch nur von der IBM empfohlene Kabel angeschlossen werden. IBM übernimmt keine Verantwortung für die Einhaltung der Schutzanforderungen, wenn das Produkt ohne Zustimmung der IBM verändert bzw. wenn Erweiterungskomponenten von Fremdherstellern ohne Empfehlung der IBM gesteckt/eingebaut werden.

EN 55022 Klasse A Geräte müssen mit folgendem Warnhinweis versehen werden:

"Warnung: Dieses ist eine Einrichtung der Klasse A. Diese Einrichtung kann im Wohnbereich Funk-Störungen verursachen; in diesem Fall kann vom Betreiber verlangt werden, angemessene Maßnahmen zu ergreifen und dafür aufzukommen."

Deutschland: Einhaltung des Gesetzes über die elektromagnetische Verträglichkeit von Geräten

Dieses Produkt entspricht dem "Gesetz über die elektromagnetische Verträglichkeit von Geräten (EMVG)". Dies ist die Umsetzung der EU-Richtlinie 2004/108/EG in der Bundesrepublik Deutschland.

Zulassungsbescheinigung laut dem Deutschen Gesetz über die elektromagnetische Verträglichkeit von Geräten (EMVG) (bzw. der EMC EG Richtlinie 2004/108/EG) für Geräte der Klasse A.

Dieses Gerät ist berechtigt, in Übereinstimmung mit dem Deutschen EMVG das EG-Konformitätszeichen - CE - zu führen.

Verantwortlich für die Konformitätserklärung nach des EMVG ist die IBM Deutschland GmbH, 70548 Stuttgart.

Generelle Informationen:

Das Gerät erfüllt die Schutzanforderungen nach EN 55024 und EN 55022 Klasse A.

Electromagnetic Interference (EMI) Statement - Russia

ВНИМАНИЕ! Настоящее изделие относится к классу А.
В жилых помещениях оно может создавать радиопомехи, для снижения которых необходимы дополнительные меры

Terms and conditions

Permissions for the use of these publications is granted subject to the following terms and conditions.

Personal Use: You may reproduce these publications for your personal, noncommercial use provided that all proprietary notices are preserved. You may not distribute, display or make derivative works of these publications, or any portion thereof, without the express consent of the manufacturer.

Commercial Use: You may reproduce, distribute and display these publications solely within your enterprise provided that all proprietary notices are preserved. You may not make derivative works of these publications, or reproduce, distribute or display these publications or any portion thereof outside your enterprise, without the express consent of the manufacturer.

Except as expressly granted in this permission, no other permissions, licenses or rights are granted, either express or implied, to the publications or any data, software or other intellectual property contained therein.

The manufacturer reserves the right to withdraw the permissions granted herein whenever, in its discretion, the use of the publications is detrimental to its interest or, as determined by the manufacturer, the above instructions are not being properly followed.

You may not download, export or re-export this information except in full compliance with all applicable laws and regulations, including all United States export laws and regulations.

THE MANUFACTURER MAKES NO GUARANTEE ABOUT THE CONTENT OF THESE PUBLICATIONS. THESE PUBLICATIONS ARE PROVIDED "AS-IS" AND WITHOUT WARRANTY OF ANY KIND, EITHER EXPRESSED OR IMPLIED, INCLUDING BUT NOT LIMITED TO IMPLIED WARRANTIES OF MERCHANTABILITY, NON-INFRINGEMENT, AND FITNESS FOR A PARTICULAR PURPOSE.

BULL CEDOC
357 AVENUE PATTON
B.P.20845
49008 ANGERS CEDEX 01
FRANCE

REFERENCE
86 A1 99FA 01