

E5-700 Rack features and installing systems or expansion units into a rack

ESCALA Power7



REFERENCE
86 A1 14FF 02

ESCALA Power7

E5-700 Rack features and installing systems or expansion units into a rack

This publication concerns the following models:

- Bull Escala E5-700 (Power 750 / 8233-E8B)
- Bull Escala M6-700 (Power 770 / 9117-MMB)
- Bull Escala M7-700 (Power 780 / 9179-MHB)
- Bull Escala E1-700 (Power 710 / 8231-E2B)
- Bull Escala E2-700 / E2-700T (Power 720 / 8202-E4B)
- Bull Escala E3-700 (Power 730 / 8231-E2B)
- Bull Escala E4-700 / E4-700T (Power 740 / 8205-E6B)

References to Power 755 / 8236-E8C models are irrelevant.

Hardware

September 2010

BULL CEDOC
357 AVENUE PATTON
B.P.20845
49008 ANGERS CEDEX 01
FRANCE

REFERENCE
86 A1 14FF 02

The following copyright notice protects this book under Copyright laws which prohibit such actions as, but not limited to, copying, distributing, modifying, and making derivative works.

Copyright © Bull SAS 2007-2010

Printed in France

Suggestions and criticisms concerning the form, content, and presentation of this book are invited. A form is provided at the end of this book for this purpose.

To order additional copies of this book or other Bull Technical Publications, you are invited to use the Ordering Form also provided at the end of this book.

Trademarks and Acknowledgements

We acknowledge the right of proprietors of trademarks mentioned in this book.

The information in this document is subject to change without notice. Bull will not be liable for errors contained herein, or for incidental or consequential damages in connection with the use of this material.

Contents

| | |
|---|------------|
| Safety notices | vii |
| Chapter 1. Racks, rack features, and installing systems or expansion units into a rack | 1 |
| Chapter 2. What's new in Racks, rack features, and installing systems or expansion units into a rack | 3 |
| Chapter 3. Installing the rack. | 5 |
| Installing the 7014-T00 or 7014-T42 racks | 5 |
| Completing a parts inventory | 5 |
| Positioning the rack | 5 |
| Leveling the rack | 6 |
| Attaching the stabilizer brackets | 7 |
| Attaching the rack to a concrete floor | 8 |
| Attaching the rack to the concrete floor beneath a raised floor | 13 |
| Connecting the power distribution system | 17 |
| Checking the ac outlets | 17 |
| Attaching the front or back ac electrical outlet | 18 |
| Installing the ac outlet-mounting plates with ac outlets | 18 |
| Installing the ac outlet-mounting plate without ac outlets | 20 |
| Connecting a dc power source | 21 |
| Chapter 4. Installing a system or expansion unit into a rack. | 27 |
| Installing the model 8233-E8B, 8236-E8C, 9117-MMB, or 9179-MHB into a rack | 27 |
| Determining the location | 29 |
| Marking the location | 30 |
| Attaching the 8233-E8B and 8236-E8C mounting hardware to the rack | 31 |
| Installing the cable-management arm | 38 |
| Connecting the power cables to the system | 39 |
| Installing the model 5802 or 5877 into a rack | 40 |
| Determining the location | 41 |
| Marking the location | 42 |
| Attaching the mounting hardware to the rack | 43 |
| Installing the 5802 or 5877 on the rail assembly | 46 |
| Installing the model 5886 into a rack | 48 |
| Determining the location | 50 |
| Marking the location | 51 |
| Attaching the mounting hardware to the rack | 52 |
| Installing the 5886 on the rail assembly | 54 |
| Installing the 5796 or 7314-G30 expansion unit in a rack | 56 |
| Powering off the system and removing power | 58 |
| Marking the location | 58 |
| Installing the standard (fixed length) rails | 59 |
| Installing the expandable rails and extension bracket into the rack | 60 |
| Installing the shell | 61 |
| Installing the expansion unit | 63 |
| Attaching the power controller (SPCN), and power cables | 65 |
| Powering on the system | 65 |
| Installing the model 5786 or 7031-D24 into a rack | 65 |
| Completing a parts inventory | 66 |
| Determining the location | 67 |
| Marking the location | 68 |
| Attaching the mounting hardware to the rack | 68 |
| Installing the 5786 or 7031-D24 on the rail assembly | 70 |

| | |
|---|------------|
| Attaching the cable-management arm to the standard rails | 73 |
| Chapter 5. Removing and replacing 7014-T00 or 7014-T42 side panels | 75 |
| Replacing a 7014-T00 or 7014-T42 side panel | 75 |
| Chapter 6. Removing and replacing 7014-T00 or 7014-T42 trim panels | 77 |
| Replacing the 7014-T00 or 7014-T42 trim panels | 77 |
| Chapter 7. Attaching the rack doors | 79 |
| Attaching a high-perforation front door | 79 |
| Rack safety notices | 80 |
| Chapter 8. Installing the rack security kit | 83 |
| Chapter 9. Ruggedized kit | 87 |
| Releasing the ruggedized brace | 88 |
| Releasing the side panel with a ruggedized kit | 88 |
| Chapter 10. Connecting multiple racks with rack-to-rack attachment kit. | 91 |
| Chapter 11. Rack status beacon | 95 |
| Installing the rack status beacon | 95 |
| Connecting multiple junction boxes | 97 |
| Chapter 12. Installing or removing a rack-mounted system-unit latch bracket | 99 |
| Chapter 13. Removing and replacing the rack top cover | 101 |
| Removing the rack top cover | 101 |
| Replacing the rack top cover | 103 |
| Chapter 14. Power distribution unit plus. | 107 |
| Installing the PDU+ in the side of a rack | 107 |
| Installing the PDU+ horizontally in a rack. | 109 |
| Setting up power monitoring using the PDU+ | 113 |
| Using the IBM DPI Configuration Utility | 113 |
| Connecting the console | 114 |
| Using HyperTerminal. | 114 |
| Configuration Utility menu options | 114 |
| Setting the IP address | 115 |
| Using the Web interface | 115 |
| Starting the Web interface | 115 |
| Modifying the basic settings | 115 |
| Changing the superuser name and password | 116 |
| Identifying the PDU+ and Web/SNMP card | 116 |
| Adding users | 116 |
| Changing the date and time | 116 |
| Changing event alerts | 116 |
| Changing the network information | 117 |
| Changing the network configuration. | 117 |
| History and event log summaries. | 117 |
| Viewing the history log | 117 |
| Viewing the event log | 117 |
| Chapter 15. Removing and replacing the expansion unit cover or door | 119 |
| Removing the front cover on the 7314-G30 or 5796 | 119 |
| Installing the front cover on the 7314-G30 or 5796 | 119 |
| Chapter 16. Removing and replacing covers on the 8233-E8B or 8236-E8C system | 121 |

| | |
|---|-----|
| Removing the service access cover from an 8233-E8B or 8236-E8C system | 121 |
| Installing the service access cover on an 8233-E8B or 8236-E8C system | 122 |
| Removing the front cover from an 8233-E8B or 8236-E8C system | 122 |
| Installing the front cover on an 8233-E8B or 8236-E8C system | 123 |
| Installing the front cover on the 7314-G30 or 5796 | 124 |

Chapter 17. Placing the rack-mounted 8233-E8B or 8236-E8C system into the service position or operating position 127

| | |
|---|-----|
| Placing the rack-mounted system or expansion unit in the service position | 127 |
| Placing the rack-mounted system or expansion unit in the operating position | 130 |
| Placing a 8233-E8B or 8236-E8C in the service position | 131 |
| Placing the 8233-E8B or 8236-E8C in the operating position | 134 |

Appendix. Notices 137

| | |
|---------------------------------------|-----|
| Trademarks | 138 |
| Electronic emission notices | 138 |
| Class A Notices. | 138 |
| Terms and conditions. | 142 |

Safety notices

Safety notices may be printed throughout this guide:

- **DANGER** notices call attention to a situation that is potentially lethal or extremely hazardous to people.
- **CAUTION** notices call attention to a situation that is potentially hazardous to people because of some existing condition.
- **Attention** notices call attention to the possibility of damage to a program, device, system, or data.

World Trade safety information

Several countries require the safety information contained in product publications to be presented in their national languages. If this requirement applies to your country, a safety information booklet is included in the publications package shipped with the product. The booklet contains the safety information in your national language with references to the U.S. English source. Before using a U.S. English publication to install, operate, or service this product, you must first become familiar with the related safety information in the booklet. You should also refer to the booklet any time you do not clearly understand any safety information in the U.S. English publications.

German safety information

Das Produkt ist nicht für den Einsatz an Bildschirmarbeitsplätzen im Sinne § 2 der Bildschirmarbeitsverordnung geeignet.

Laser safety information

IBM[®] servers can use I/O cards or features that are fiber-optic based and that utilize lasers or LEDs.

Laser compliance

IBM servers may be installed inside or outside of an IT equipment rack.

DANGER

When working on or around the system, observe the following precautions:

Electrical voltage and current from power, telephone, and communication cables are hazardous. To avoid a shock hazard:

- Connect power to this unit only with the IBM provided power cord. Do not use the IBM provided power cord for any other product.
- Do not open or service any power supply assembly.
- Do not connect or disconnect any cables or perform installation, maintenance, or reconfiguration of this product during an electrical storm.
- The product might be equipped with multiple power cords. To remove all hazardous voltages, disconnect all power cords.
- Connect all power cords to a properly wired and grounded electrical outlet. Ensure that the outlet supplies proper voltage and phase rotation according to the system rating plate.
- Connect any equipment that will be attached to this product to properly wired outlets.
- When possible, use one hand only to connect or disconnect signal cables.
- Never turn on any equipment when there is evidence of fire, water, or structural damage.
- Disconnect the attached power cords, telecommunications systems, networks, and modems before you open the device covers, unless instructed otherwise in the installation and configuration procedures.
- Connect and disconnect cables as described in the following procedures when installing, moving, or opening covers on this product or attached devices.

To Disconnect:

1. Turn off everything (unless instructed otherwise).
2. Remove the power cords from the outlets.
3. Remove the signal cables from the connectors.
4. Remove all cables from the devices

To Connect:

1. Turn off everything (unless instructed otherwise).
2. Attach all cables to the devices.
3. Attach the signal cables to the connectors.
4. Attach the power cords to the outlets.
5. Turn on the devices.

(D005)

DANGER

Observe the following precautions when working on or around your IT rack system:

- Heavy equipment—personal injury or equipment damage might result if mishandled.
- Always lower the leveling pads on the rack cabinet.
- Always install stabilizer brackets on the rack cabinet.
- To avoid hazardous conditions due to uneven mechanical loading, always install the heaviest devices in the bottom of the rack cabinet. Always install servers and optional devices starting from the bottom of the rack cabinet.
- Rack-mounted devices are not to be used as shelves or work spaces. Do not place objects on top of rack-mounted devices.



- Each rack cabinet might have more than one power cord. Be sure to disconnect all power cords in the rack cabinet when directed to disconnect power during servicing.
- Connect all devices installed in a rack cabinet to power devices installed in the same rack cabinet. Do not plug a power cord from a device installed in one rack cabinet into a power device installed in a different rack cabinet.
- An electrical outlet that is not correctly wired could place hazardous voltage on the metal parts of the system or the devices that attach to the system. It is the responsibility of the customer to ensure that the outlet is correctly wired and grounded to prevent an electrical shock.

CAUTION

- Do not install a unit in a rack where the internal rack ambient temperatures will exceed the manufacturer's recommended ambient temperature for all your rack-mounted devices.
- Do not install a unit in a rack where the air flow is compromised. Ensure that air flow is not blocked or reduced on any side, front, or back of a unit used for air flow through the unit.
- Consideration should be given to the connection of the equipment to the supply circuit so that overloading of the circuits does not compromise the supply wiring or overcurrent protection. To provide the correct power connection to a rack, refer to the rating labels located on the equipment in the rack to determine the total power requirement of the supply circuit.
- *(For sliding drawers.)* Do not pull out or install any drawer or feature if the rack stabilizer brackets are not attached to the rack. Do not pull out more than one drawer at a time. The rack might become unstable if you pull out more than one drawer at a time.
- *(For fixed drawers.)* This drawer is a fixed drawer and must not be moved for servicing unless specified by the manufacturer. Attempting to move the drawer partially or completely out of the rack might cause the rack to become unstable or cause the drawer to fall out of the rack.

(R001)

CAUTION:

Removing components from the upper positions in the rack cabinet improves rack stability during relocation. Follow these general guidelines whenever you relocate a populated rack cabinet within a room or building:

- Reduce the weight of the rack cabinet by removing equipment starting at the top of the rack cabinet. When possible, restore the rack cabinet to the configuration of the rack cabinet as you received it. If this configuration is not known, you must observe the following precautions:
 - Remove all devices in the 32U position and above.
 - Ensure that the heaviest devices are installed in the bottom of the rack cabinet.
 - Ensure that there are no empty U-levels between devices installed in the rack cabinet below the 32U level.
- If the rack cabinet you are relocating is part of a suite of rack cabinets, detach the rack cabinet from the suite.
- Inspect the route that you plan to take to eliminate potential hazards.
- Verify that the route that you choose can support the weight of the loaded rack cabinet. Refer to the documentation that comes with your rack cabinet for the weight of a loaded rack cabinet.
- Verify that all door openings are at least 760 x 230 mm (30 x 80 in.).
- Ensure that all devices, shelves, drawers, doors, and cables are secure.
- Ensure that the four leveling pads are raised to their highest position.
- Ensure that there is no stabilizer bracket installed on the rack cabinet during movement.
- Do not use a ramp inclined at more than 10 degrees.
- When the rack cabinet is in the new location, complete the following steps:
 - Lower the four leveling pads.
 - Install stabilizer brackets on the rack cabinet.
 - If you removed any devices from the rack cabinet, repopulate the rack cabinet from the lowest position to the highest position.
- If a long-distance relocation is required, restore the rack cabinet to the configuration of the rack cabinet as you received it. Pack the rack cabinet in the original packaging material, or equivalent. Also lower the leveling pads to raise the casters off of the pallet and bolt the rack cabinet to the pallet.

(R002)

(L001)



(L002)



(L003)

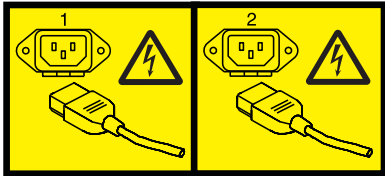

or



All lasers are certified in the U.S. to conform to the requirements of DHHS 21 CFR Subchapter J for class 1 laser products. Outside the U.S., they are certified to be in compliance with IEC 60825 as a class 1 laser product. Consult the label on each part for laser certification numbers and approval information.

CAUTION:

This product might contain one or more of the following devices: CD-ROM drive, DVD-ROM drive, DVD-RAM drive, or laser module, which are Class 1 laser products. Note the following information:

- Do not remove the covers. Removing the covers of the laser product could result in exposure to hazardous laser radiation. There are no serviceable parts inside the device.
- Use of the controls or adjustments or performance of procedures other than those specified herein might result in hazardous radiation exposure.

(C026)

CAUTION:

Data processing environments can contain equipment transmitting on system links with laser modules that operate at greater than Class 1 power levels. For this reason, never look into the end of an optical fiber cable or open receptacle. (C027)

CAUTION:

This product contains a Class 1M laser. Do not view directly with optical instruments. (C028)

CAUTION:

Some laser products contain an embedded Class 3A or Class 3B laser diode. Note the following information: laser radiation when open. Do not stare into the beam, do not view directly with optical instruments, and avoid direct exposure to the beam. (C030)

Power and cabling information for NEBS (Network Equipment-Building System) GR-1089-CORE

The following comments apply to the IBM servers that have been designated as conforming to NEBS (Network Equipment-Building System) GR-1089-CORE:

The equipment is suitable for installation in the following:

- Network telecommunications facilities
- Locations where the NEC (National Electrical Code) applies

The intrabuilding ports of this equipment are suitable for connection to intrabuilding or unexposed wiring or cabling only. The intrabuilding ports of this equipment *must not* be metallically connected to the interfaces that connect to the OSP (outside plant) or its wiring. These interfaces are designed for use as intrabuilding interfaces only (Type 2 or Type 4 ports as described in GR-1089-CORE) and require isolation from the exposed OSP cabling. The addition of primary protectors is not sufficient protection to connect these interfaces metallically to OSP wiring.

Note: All Ethernet cables must be shielded and grounded at both ends.

The ac-powered system does not require the use of an external surge protection device (SPD).

The dc-powered system employs an isolated DC return (DC-I) design. The DC battery return terminal *shall not* be connected to the chassis or frame ground.

Chapter 1. Racks, rack features, and installing systems or expansion units into a rack

Learn about the procedures used to install racks. Also detailed procedures are provided for installing rack features, systems and expansion units into a rack.

You can perform these tasks or contact a service provider to perform the tasks for you. You might be charged a fee by the service provider for this service.

Chapter 2. What's new in Racks, rack features, and installing systems or expansion units into a rack

Read about new or significantly changed information in Racks, rack features, and installing systems or expansion units into a rack since the previous update of this topic collection.

September 2010

Content updates include the following:

- Added procedures for Installing the model 8231-E2B into a rack.
- Added procedures for Installing the model 8202-E4B or 8205-E6B into a rack.
- Added procedures for Chapter 6, "Removing and replacing 7014-T00 or 7014-T42 trim panels," on page 77.

Chapter 3. Installing the rack

This section describes all the tasks required to install 7014-T00 or 7014-T42 racks. The full spectrum of related tasks is described, from completing a parts inventory to finally connecting to a dc power source.

Installing the 7014-T00 or 7014-T42 racks

Use this information to install the 7014-T00 or 7014-T42 racks.

If you are installing a rack security kit in this rack, see Chapter 8, “Installing the rack security kit,” on page 83 after you have installed the rack.

Before installing a rack, read the “Rack safety notices” on page 80.

Completing a parts inventory

Before beginning the rack installation it is a good idea to do a parts inventory. This section guides you in performing this task.

If you have not done so, complete a parts inventory before installing the unit in the rack:

1. Locate the kitting report in an accessory box.
2. Ensure that you received all of the features that you ordered and all of the parts on the kitting report.

If there are incorrect, missing, or damaged parts, contact:

- Your IBM reseller
- IBM support (see Directory of worldwide contacts Web site at <http://www.ibm.com/planetwide>  for contact information for your country)
- IBM Rochester Manufacturing Automated Information Line at 1-800-300-8751 (United States only)

Positioning the rack

Proper rack positioning is needed to comply with safety and regulatory requirements. Use the procedure in this section to perform this task.

After the rack has been placed into its location on the floor, lock each caster by tightening the locking screw. See the following illustration for the locking screw location (2). Remove all the tape and packing materials from the rack.

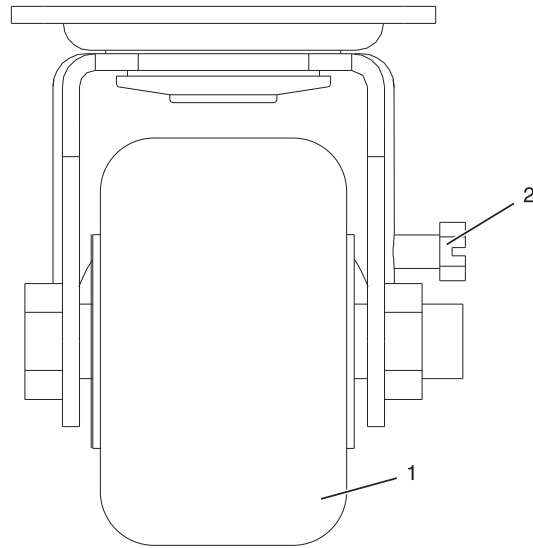

- 1 Caster
- 2 Locking screw

Figure 1. Tightening the locking screw

Use the following to determine the next step:

- To bolt the rack to a concrete floor, go to “Attaching the rack to a concrete floor” on page 8.
- To bolt the rack to a concrete floor beneath a raised floor, go to “Attaching the rack to the concrete floor beneath a raised floor” on page 13.
- To attach the rack to the floor, go to “Leveling the rack.”

Leveling the rack

If you need to level the rack, use the procedure described in this section.

To level the rack, complete the following steps:

1. Loosen the jam nut on each leveling foot.
2. Rotate each leveling foot downward until it contacts the surface on which the rack is placed.
3. Adjust the leveling feet downward as needed until the rack is level. When the rack is level, tighten the jam nuts against the base.

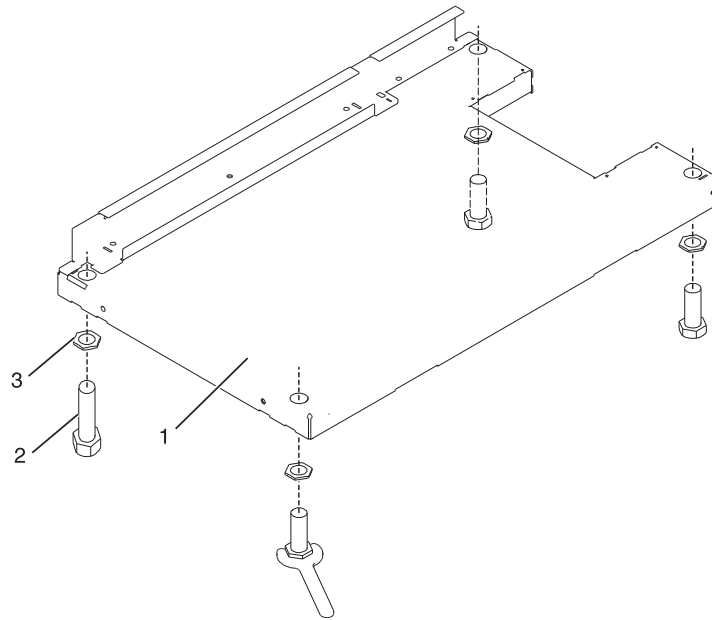

- 1 Rack Front (base)
- 2 Leveling Foot (quantity 4)
- 3 Jam Nut (quantity 4)

Figure 2. Adjusting the leveling feet

Attaching the stabilizer brackets

You might need to attach the stabilizer brackets to the rack. This section helps you determine whether stabilizer brackets are necessary and describes how to attach them if needed.

If the front or back ac electrical outlets are going to be installed in the rack, you cannot attach the stabilizer brackets. The rack must be bolted to the floor. Stabilizer brackets are used only if you will not be bolting the rack to the floor. If you are going to bolt the rack to the floor, go to “Attaching the rack to a concrete floor” on page 8.

To attach the stabilizer brackets to the bottom of the rack, do the following:

Note: Before installing the stabilizer brackets, see “Attaching the front or back ac electrical outlet” on page 18 for instruction on installing the ac outlet-mounting plates.

1. Align the slots of one of the stabilizer brackets with the mounting holes at the bottom front of the rack.
2. Install the two mounting screws.
3. Ensure that the base of the stabilizer bracket rests firmly on the floor. Use the Allen wrench that was supplied with the rack to tighten the mounting screws alternately until they are tight.

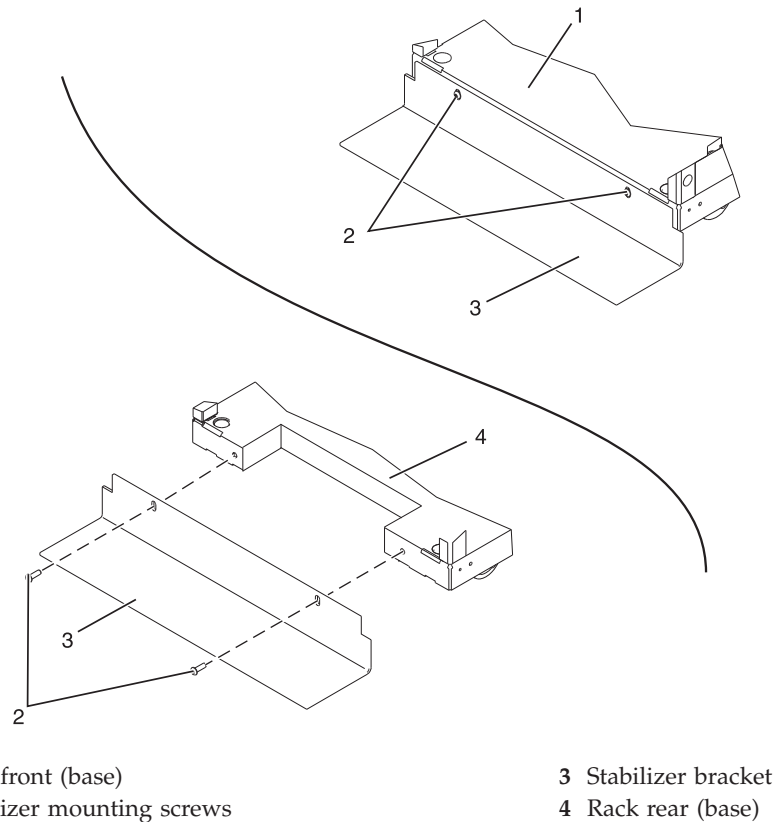

Figure 3. Attaching the stabilizer brackets

4. To install the second stabilizer bracket on the back of the rack, repeat steps 1 through 3.

Attaching the rack to a concrete floor

If you plan to install the front or back ac electrical outlets in the rack, the rack must be bolted to the floor. This section describes how to perform this task for a concrete floor.

Obtain the services of a mechanical contractor to attach the rack-mounting plates to the concrete floor. The mechanical contractor must determine that the hardware being used to secure the rack-mounting plates to the concrete floor is sufficient to meet the requirements for the installation.

To attach the rack to a concrete floor, do the following:

1. Put the rack in its predetermined location, and tighten the locking screws on the casters.
2. If they are installed, remove the top, left, and right trim panels. The trim panels are held in place with spring clips. See the following illustration.

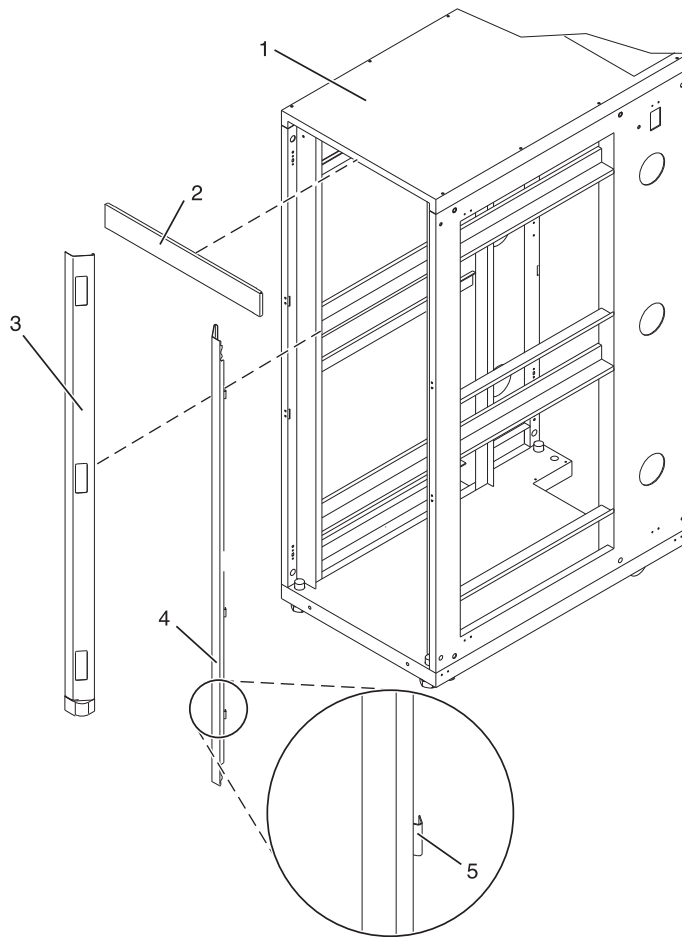

- 1 Rack chassis
- 2 Top trim panel
- 3 Left-side trim panel

- 4 Right-side trim panel
- 5 Spring clip

Figure 4. Removing the trim panels

3. If they are installed, remove the front and back doors. After the rack doors have been removed, go to the next substep. To remove a rack door:
 - a. Unlock and open the door.
 - b. Grasp the door firmly with both hands and pull it away from the hinges.
4. Locate the hardware mounting kit and the two mounting plates. Refer to the following illustration when reviewing the contents of the hardware mounting kit. The hardware mounting kit contains the following:
 - 4 Rack-mounting bolts
 - 4 Thin washers
 - 8 Plastic isolator bushings
 - 4 Thick washers
 - 4 Spacers
5. If you are installing an ac-powered rack, temporarily install the lower plastic isolator bushings to help you locate the mounting locations for the stabilizer bracket. After the stabilizer bracket has been

correctly located, remove the lower plastic isolator bushings.

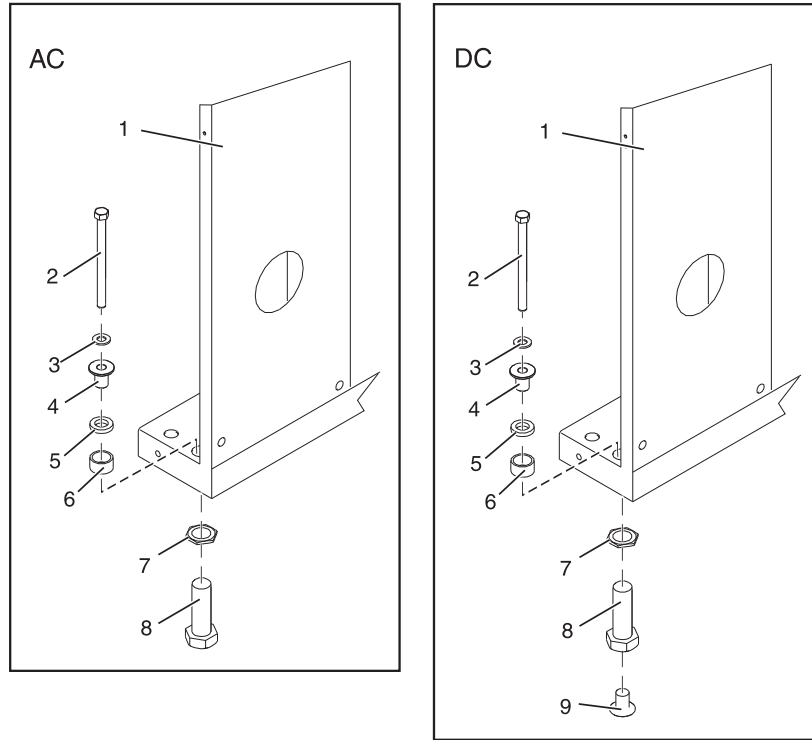
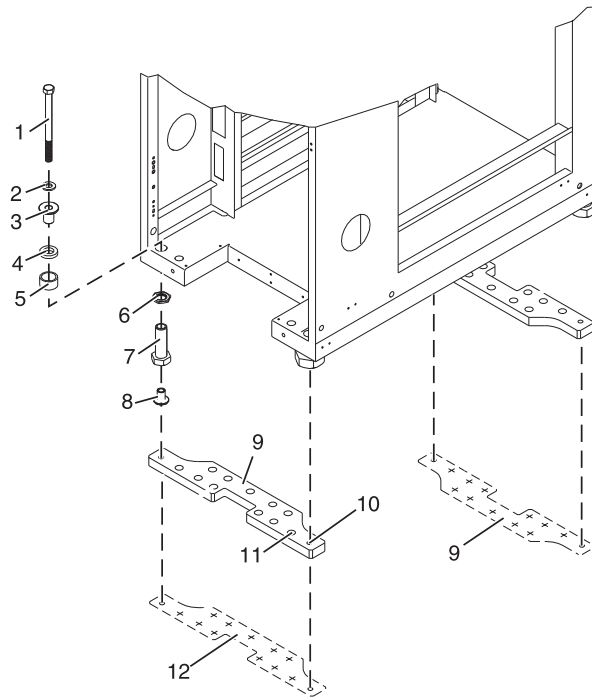

Figure 5. Installing ac-power mounting plates

- | | |
|--------------------------------|--|
| 1 Rack chassis | 7 Jam nut |
| 2 Rack-mounting bolt | 8 Leveling foot |
| 3 Thin washer | 9 Lower plastic isolator bushing (used only on dc powered systems) |
| 4 Top plastic isolator bushing | AC Typical leveling foot installation for an ac-powered rack |
| 5 Thick washer | DC Typical leveling foot installation for a dc-powered rack |
| 6 Spacer | |

6. Position the two mounting plates in the approximate mounting location under the rack.
7. Create a rack-mounting bolt assembly by adding the following items, in the order listed, to each rack-mounting bolt.
 - a. Thin washer
 - b. Top plastic isolator bushing
 - c. Thick flat washer
 - d. Spacer
8. Insert a rack-mounting bolt assembly through each of the leveling feet.
9. Reposition the rack-mounting plates under the four rack-mounting bolts so that the mounting bolts are centered directly over the threaded bolt holes.
10. Turn the rack-mounting bolts four complete turns into the mounting plate's threaded bolt holes.



- | | |
|--------------------------------|--|
| 1 Rack-mounting bolt | 7 Leveling foot |
| 2 Thin washer | 8 Lower plastic isolator bushing (Used only on dc powered systems) |
| 3 Top plastic isolator bushing | 9 Mounting plate |
| 4 Thick washer | 10 Threaded hole (Used to secure the rack to stabilizer bracket.) |
| 5 Spacer | 11 Anchor bolt hole |
| 6 Jam nut | 12 Traced pattern (Pattern to be traced onto the floor using the stabilizer bracket as a template) |

Figure 6. Securing the rack to the floor

11. Mark the floor around the edges of both stabilizer brackets.
12. Mark the plate bolt-down holes that are accessible through the opening in the rear of the rack.
13. Remove the rack-mounting bolt assemblies.
14. If you are installing an ac-powered rack, remove the bottom isolator bushing from each of the leveling feet.
15. Remove the stabilizer brackets from the marked locations.
16. Loosen each of the locking screws on the casters.
17. Move the rack so that it is clear of both areas that were marked on the floor for the stabilizer bracket locations.
18. Reposition the stabilizer brackets within the marked areas.
19. Mark the floor at the center of all holes in both stabilizer brackets.
20. Remove the two rack-mounting plates from the marked areas.
21. At the marked location of the threaded rack-mounting bolt holes, drill four clearance holes into the concrete floor. Each clearance hole should be approximately 1-inch deep. This depth allows the rack-mounting bolts enough room to protrude past the thickness of the stabilizer brackets.

Note: You *must* use a minimum of two anchor bolts for each rack-mounting plate to securely attach the plate to the concrete floor. Because some of the holes in each rack-mounting plate might align with concrete reinforcement rods embedded in the concrete, some of the rack-mounting plate holes might not be usable.

22. Select at least two suitable hole locations for each stabilizer bracket bolt. The selected locations should be as close to the threaded bolt holes as possible. Be sure that the holes selected at the back of the rack are accessible. Drill holes at the selected locations into the concrete floor.
23. Position the stabilizer brackets over the concrete anchors.
24. Securely bolt the front stabilizer bracket to the concrete floor.
25. Position the stabilizer bracket over the concrete anchors.
26. Securely bolt the back stabilizer bracket to the concrete floor.

Note: The size of the anchor bolts and concrete anchors *must* be determined by the mechanical contractor who will be installing the rack-mounting plate.

27. Position the rack over the stabilizer bracket.
28. Insert each of the stabilizer bracket bolts through a flat washer, a plastic isolator bushing and a thick washer, and through a leveling foot.
29. Align the four stabilizer brackets bolts with the four tapped holes in the two mounting plates and turn three to four rotations.
30. Tighten the locking screw on each caster.
31. Adjust the leveling feet downward as needed until the rack is level. When the rack is level, tighten the jam nuts against the base of the rack.

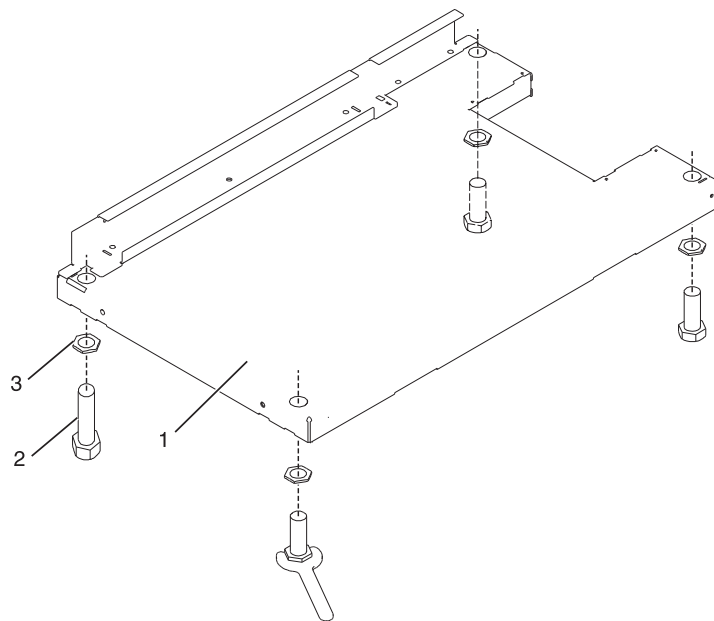

- 1 Rack front (base)
- 2 Leveling foot (quantity 4)
- 3 Jam nut (quantity 4)

Figure 7. Adjusting the leveling feet

32. If you have multiple racks that are connected in a suite (bolted to each other), go to Chapter 10, "Connecting multiple racks with rack-to-rack attachment kit," on page 91. Otherwise, torque the four bolts to 40-50 ft-lbs (54-67 nm).

33. If you are not installing doors on your rack, install the top, left, and right trim panel.
34. Connect the power distribution system as described in “Connecting the power distribution system” on page 17.
35. After all racks are bolted down, go to “Attaching the front or back ac electrical outlet” on page 18.
36. If you are not going to attach a front electrical outlet and you are installing rack doors, go to Chapter 7, “Attaching the rack doors,” on page 79

Attaching the rack to the concrete floor beneath a raised floor

If you plan to install front or back ac electrical outlets in the rack, the rack must be bolted to the floor. When you attach the rack to a concrete floor, which lays beneath a raised floor, follow the procedure described in this section.

Obtain the services of a mechanical contractor to attach the rack-mounting plates to the concrete floor. The mechanical contractor needs to determine that the hardware being used to secure the rack-mounting plates to the concrete floor is sufficient to meet the requirements for the installation.

To attach the rack to a concrete floor beneath a raised floor, do the following:

1. Put your rack in its predetermined location and tighten the locking screws on the casters.
2. If installed, remove the top, left and right trim panels. The trim panels are held in place with spring clips. See the following illustration.

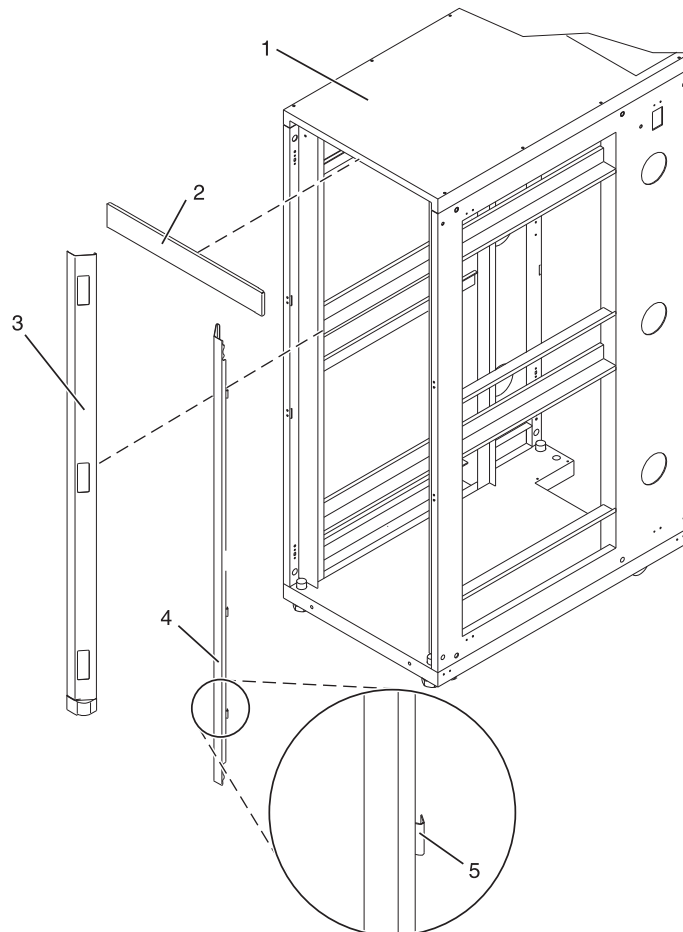

- 1 Rack chassis
- 2 Top trim panel
- 3 Left-side trim panel

- 4 Right-side trim panel
- 5 Spring clip

Figure 8. Removing the trim panels

3. If installed, remove the front and rear doors. To remove a rack door, go to . After the rack doors have been removed, go to the next substep.
4. Locate the hardware mounting kit and the two mounting plates. Refer to the following illustration when reviewing the contents of the hardware mounting kit. The hardware mounting kit contains the following:
 - Four rack-mounting bolts
 - Four thin washers
 - Eight plastic isolator bushings
 - Four thick washers
 - Four spacers
5. If you are installing an ac-powered rack, temporarily install the lower plastic isolator bushings to help you locate the rack-mounting plate. After the mounting plate has been correctly located, remove the lower plastic isolator bushings.

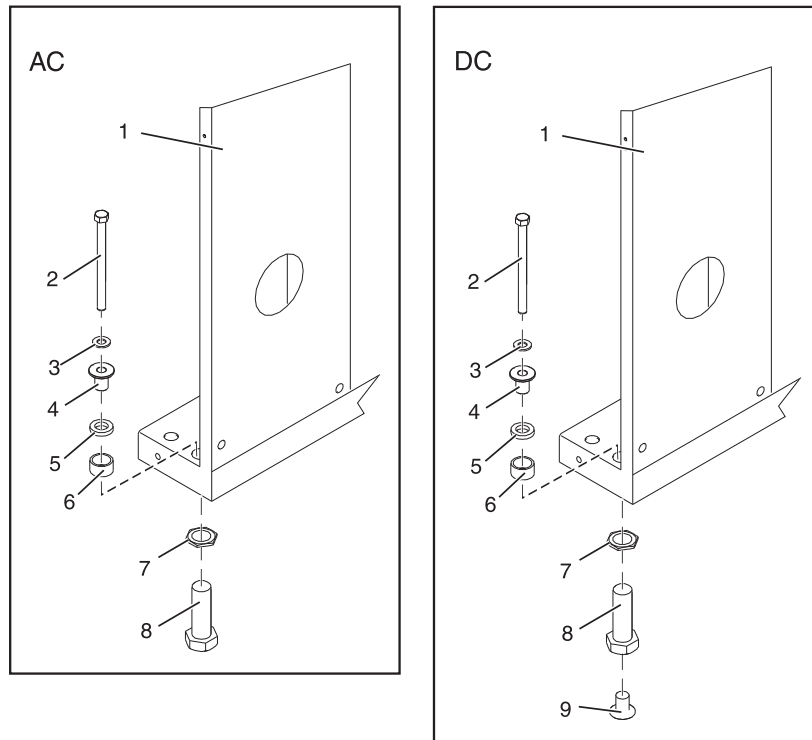

Figure 9. Installing the ac power-mounting plates

- | | |
|--------------------------------|--|
| 1 Rack chassis | 7 Jam nut |
| 2 Rack-mounting bolt | 8 Leveling foot |
| 3 Thin washer | 9 Lower plastic isolator bushing (used only on dc powered systems) |
| 4 Top plastic isolator bushing | AC Typical leveling foot installation for an ac-powered rack |
| 5 Thick washer | DC Typical leveling foot installation for an dc-powered rack |
| 6 Spacer | |

6. Position the two mounting plates in the approximate mounting location under the rack.
7. Create a rack-mounting bolt assembly by adding the following items, in the order listed, to each rack-mounting bolt.
 - a. Thin washer
 - b. Top plastic isolator bushing
 - c. Thick flat washer
 - d. Spacer
8. Insert a rack-mounting bolt assembly through each of the leveling feet.
9. Reposition the rack-mounting plates under the four rack-mounting bolts so that the mounting bolts are centered directly over the threaded bolt holes.
10. Turn the rack-mounting bolts four complete turns into the mounting plate's threaded bolt holes.
11. Mark the raised-floor panel around the edges of front and back rack-mounting plates.
12. Mark the plate bolt-down holes that are accessible through the opening in the back of the rack.
13. Remove the rack-mounting bolt assemblies.
14. If you are installing an ac-powered rack, remove the bottom isolator bushing from each of the leveling feet.
15. Remove the rack-mounting plates from the marked locations.
16. Loosen each of the locking screws on the casters.
17. Move the rack so that it is clear of both areas that were marked on the floor for the rack-mounting plate locations.
18. Reposition the mounting plates within the marked areas.
19. Mark the raised-floor panel at the center of each hole in the rack-mounting plates (including the tapped holes).
20. Remove the two rack-mounting plates from the marked locations on the raised floor panel.
21. Drill two clearance holes on each end of each rack-mounting plate. The drilled holes should be approximately 1-inch deep. This depth will accommodate any rack-mounting bolt extending past the rack-mounting plate when securing the rack to the rack-mounting plate.
22. For each rack-mounting plate, select at least two suitable hole locations. Select the hole locations as close to the threaded hole areas as possible. Be sure the hole locations selected at the back of the rack are accessible.
23. Drill pass-through holes in the raised-floor panel. The pass-through holes allow the anchor bolts to be inserted into the rack-mounting plate and pass through the raised floor panel to the concrete floor.

Note: You *must* use a minimum of two anchor bolts for each rack-mounting plate to securely attach the rack-mounting plate through the raised-floor panel to the concrete floor. Because some of the holes in each rack-mounting plate may align with concrete reinforcement rods imbedded in the concrete, some of the rack-mounting plate holes may not be usable.

24. Transfer the locations of the anchor bolt holes (exclude the clearance holes drilled for the rack-mounting bolts) from the raised-floor panel to the concrete floor directly beneath, and mark the hole locations on the concrete floor.
25. Drill holes in the concrete floor to secure the anchor bolts.
26. Position the raised-floor panel back into position over the anchor bolt holes.
27. Position the front stabilizer bracket within the marked area on the raised-floor panel.
28. Using your anchor bolts, secure the front stabilizer brackets on top of the raised floor and through to the concrete floor.
29. Position the rear stabilizer brackets within the marked area on the raised-floor panel.

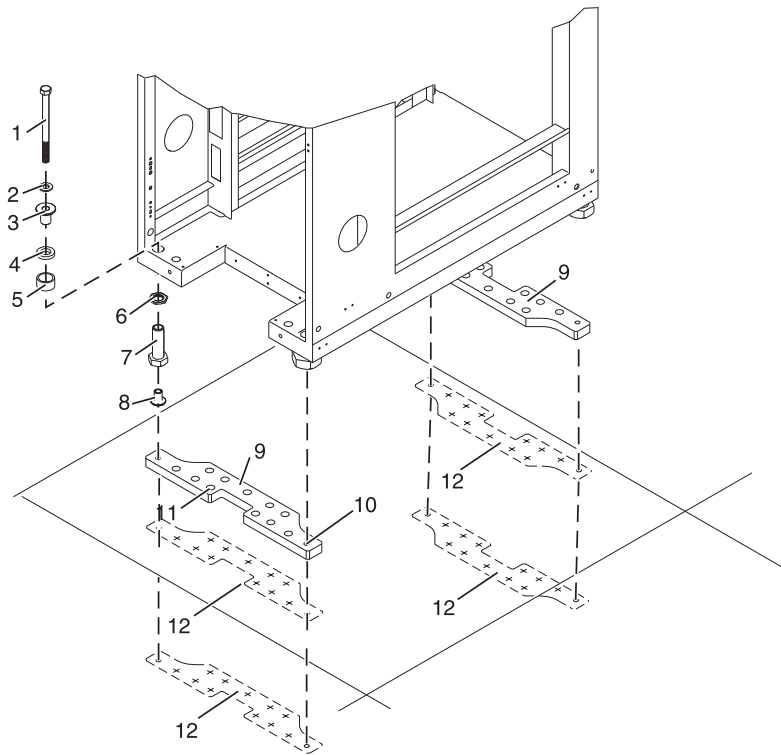

- | | |
|--------------------------------|--|
| 1 Rack-mounting bolt | 7 Leveling foot |
| 2 Thin washer | 8 Lower plastic isolator bushing (used only on dc-powered systems) |
| 3 Top plastic isolator bushing | 9 Stabilizer brackets |
| 4 Thick washer | 10 Threaded hole (used to secure the rack to mounting plate.) |
| 5 Spacer | 11 Anchor bolt hole |
| 6 Jam nut | 12 Traced pattern (pattern to be traced onto the floor using the mounting plate as a template) |

Figure 10. Securing the rack to the floor

30. Using your anchor bolts, secure the back stabilizer bracket on top of the raised floor and through to the concrete floor.
31. Replace all raised-floor panels that may have been removed when aligning and securing the anchor bolts to the concrete floor.
32. Align the rack over the front and back stabilizer brackets.
33. Insert each of the bolt assemblies through a leveling foot.
34. Align the rack-mounting bolts with the threaded holes in each stabilizer bracket. Turn each bolt three to four rotations.
35. Tighten the locking screw on each caster.
36. Adjust the leveling feet downward as needed until the rack is level. When the rack is level, tighten the jam nuts against the base of the rack.
37. If you have multiple racks that are connected as a suite (bolted to each other), go to Chapter 10, "Connecting multiple racks with rack-to-rack attachment kit," on page 91. Otherwise, torque the four bolts to 40-50 ft-lbs (54-67 nm).
38. If you are not installing doors on your rack, install the top, left, and right trim panel.

39. Connect the power distribution system as described in "Connecting the power distribution system."
40. After the rack is bolted down and you are going to attach a front electrical outlet, go to "Attaching the front or back ac electrical outlet" on page 18.
41. If you are not going to attach a front electrical outlet and you are installing rack doors, go to Chapter 7, "Attaching the rack doors," on page 79.

Connecting the power distribution system

You can use a power distribution system to monitor the individual power loads of the devices that are plugged into it. Use the procedure in this section to connect this system.

To connect a Power Distribution Unit, see Chapter 14, "Power distribution unit plus," on page 107.

Checking the ac outlets

To help ensure safety and reliable operation, you should check the ac outlets. Use the procedure in this section to perform this task.

Before you begin, ensure that you have a multimeter to check voltages and an appropriately approved ground-impedance tester to test the grounding resistances.

Note: Use only an appropriately approved ground-impedance tester to test the grounding resistances. Do not use a multimeter to measure grounding resistance.

Before plugging the rack into the ac power source, complete the following checks on the ac power source:

1. Turn off the branch circuit breaker for the ac power outlet that the rack will plug into. To the circuit breaker switch, attach tag S229-0237, which reads "Do Not Operate."

Note: All measurements are made with the receptacle faceplate in the usual installed position.

2. Some receptacles are enclosed in metal housings. For this type of receptacle, do the following steps:
 - a. Using a multimeter, check for less than 1 volt from the receptacle case to any grounded metal structure in the building, such as a raised-floor metal structure, water pipe, building steel, or similar structure.
 - b. Using a multimeter, check for less than 1 volt from the receptacle ground pin to a grounded point in the building.

Note: If the receptacle case or faceplate is painted, be sure the probe tip penetrates the paint and makes good electrical contact with the metal.

- c. Using a multimeter, check the resistance from the receptacle ground pin to the receptacle case. Check resistance from the ground pin to the building ground. The readings should be less than 1.0 ohm, which indicates the presence of a continuous grounding conductor.
3. If any of the checks made in step 2 are not correct, remove the power from the branch circuit and make the wiring corrections. Recheck the receptacle after the wiring is corrected.
4. Using a ground-impedance tester, check for infinite resistance between the ground pin of the receptacle and each of the phase pins. This is a check for a wiring short to ground or a wiring reversal.
5. Using a ground-impedance tester, check for infinite resistance between the phase pins. This is a check for a wiring short.
6. Turn on the branch circuit breaker.
7. Using a multimeter, measure for the appropriate voltages between phases. If no voltage is present on the receptacle case or grounded pin, the receptacle is safe to touch.
8. Using a multimeter, verify that the voltage at the ac outlet is correct.

Attaching the front or back ac electrical outlet

If you need to attach an ac outlet, you can use the procedure in this section to perform this task.

Attention: The front and back ac outlet-mounting plates mount through the same mounting holes in that secure the stabilizer brackets to the rack chassis. Therefore, if the rack must be bolted to the floor, the stabilizer brackets must be removed.

Install the ac outlet-mounting plates only after the rack has been bolted to the floor and the stabilizer brackets have been removed.

The following items are installed at the customer's site:

- The ac outlet-mounting plates for installing customer-supplied ac electrical outlets on the front or back of the rack. The ac outlet-mounting plate provides the mounting location for an ac electrical outlet.
- The brass ground lug for an electrostatic discharge (ESD) connection.

Note: The customer is responsible for providing both the outlets and the power cables that attach to the power source. The customer is also responsible for connecting the ac outlet correctly. These items are not field-replaceable units (FRUs).

Installing the ac outlet-mounting plates with ac outlets

If you choose to install ac mounting plates, you can follow the procedure detailed in this section to perform this task. This section also includes illustrations of the related hardware components and shows how these components relate to each other.

If you do not want ac outlets installed on the rack, go to “Installing the ac outlet-mounting plate without ac outlets” on page 20.

If you want ac outlets installed on the front or back ac outlet-mounting plate, do the following:

1. Determine the number of ac outlets that you are installing.
2. Confirm with your contractor that the number and location of ac outlets to be installed are correct.
3. Remove the blank filler plates from the ac outlet-mounting plates for the number of ac outlets being installed.
4. Install the ac outlets on the ac outlet-mounting plate.
5. Install the ground lug in the ac outlet-mounting plate using only one nut, as shown in the following illustration.
6. Securely tighten the one nut on the ground lug.
7. Locate the "Y"-shaped ground cable supplied with the mounting plate.

Note: The remaining steps can be used to install ac outlets on the front or the back of the rack.

8. Place the star washer onto the ground lug of the front ac outlet-mounting plate.
9. Place the lug on the long end of the ground cable onto the ground lug.
10. Place a ground lug nut onto the ground lug and securely tighten it.
11. Position the front ac outlet-mounting plate onto the rack frame with the ground lug fully inserted through the mounting holes in the rack.
12. Route the cable under the rack.
13. Place the star washer onto the ground lug of the back ac outlet-mounting plate.
14. Place the lug on the short end of the ground cable onto the ground lug.
15. Place a ground lug nut onto the ground lug and securely tighten it.

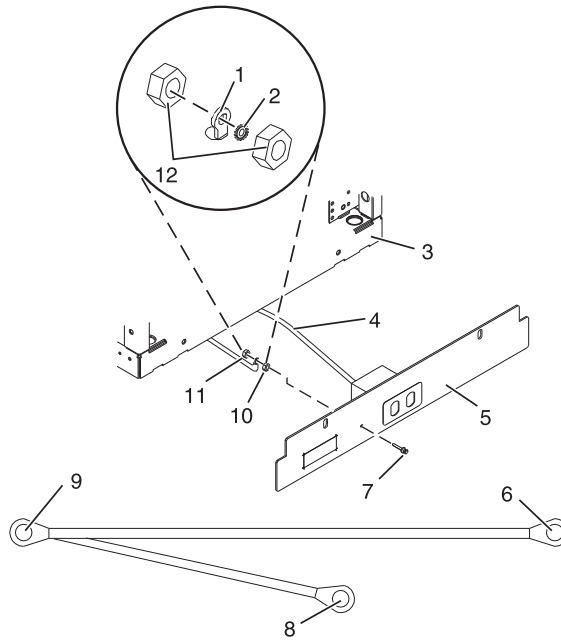

- | | |
|-------------------------------------|--|
| 1 Ground cable lug | 7 Ground lug |
| 2 Star washer | 8 Ground connector (short end of ground cable) |
| 3 Front of rack | 9 "Y" End of ground cable |
| 4 Power cable from the power source | 10 Ground lug nut (quantity 2) |
| 5 Mounting plate | 11 Long end of ground cable |
| 6 Long end of ground cable | 12 Ground lug nut (quantity 2) |

Figure 11. Installing the ground lug

16. Position the back ac outlet-mounting plate onto the rack frame with the ground lug fully inserted through the mounting holes in the rack.
17. Install the front ac outlet-mounting plate screws (stabilizer mounting screws) into the mounting plate and through the mounting holes in the rack. Securely tighten the screws.

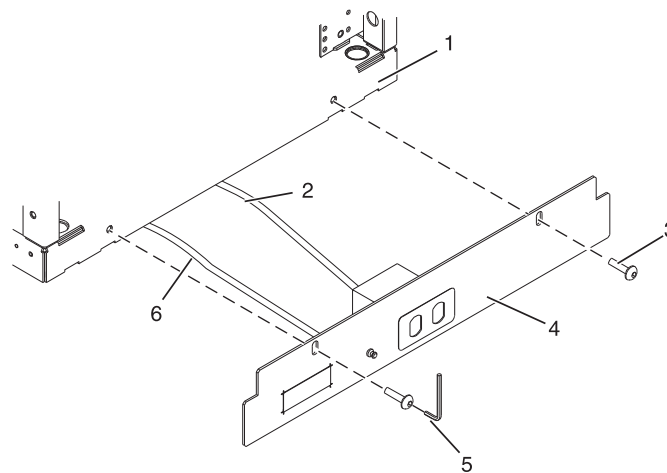

- | | |
|---|------------------|
| 1 Front or back of rack (as applicable) | 4 Mounting plate |
| 2 Power cable from power source | 5 Allen wrench |

3 Button-head screw

6 Long end of ground cable

Figure 12. Installing the front mounting plate

18. Connect the "Y"-shaped end of the ground cable to the rack frame, either near the center in the back of the rack or to the ground bus bar at the back of the rack.
19. Install the back ac outlet-mounting plate screws (stabilizer mounting screws) into the mounting plate and through the mounting holes in the rack. Securely tighten the screws.

Note: The bus bar might be located at either the top or bottom of the rack.

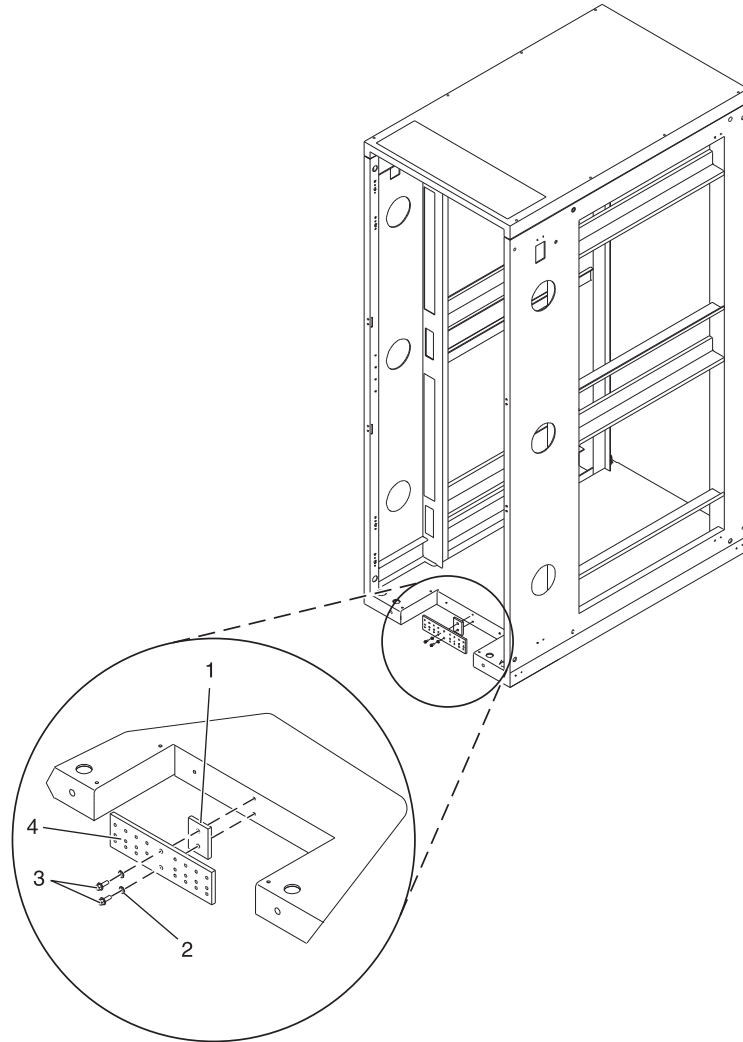

1 Bus bar mounting plate
2 Lock washer (quantity 2)

3 Hex screws (M5 x 20) (quantity 2)
4 Ground bus bar

Figure 13. Installing the back mounting plate

Installing the ac outlet-mounting plate without ac outlets

If you choose to install an outlet plate without the outlets, use the procedure in this section to perform this task.

If you do not want any ac outlets installed on the front or rear ac outlet-mounting plate, perform only “Attaching the rack to the concrete floor beneath a raised floor” on page 13 through “Connecting the power distribution system” on page 17.

For front or rear ac outlet-mounting plates, refer to “Installing the ac outlet-mounting plates with ac outlets” on page 18.

Connecting a dc power source

Some rack models (such as the 7014-T00) can support a dc power configuration for systems that require dc power. If you decide to connect a dc power source to the rack, you can use the procedure in this section to perform this task. This section also includes illustrations of the related hardware components and shows how these components relate to each other.

Note: The customer is responsible for providing and connecting the -48 V dc power source and -48 V dc power return cables from the customer's source -48 V dc to the bus bars in the power distribution panel. The customer is also responsible for connecting the ground cable to the rack frame. This procedure provides information about accessing the power distribution panel.

1. Remove the six mounting screws from the top cover of the dc power distribution panel and remove the top cover.
2. If they are installed, remove the four screws from the cable channel cover.
3. Remove the cable channel cover.

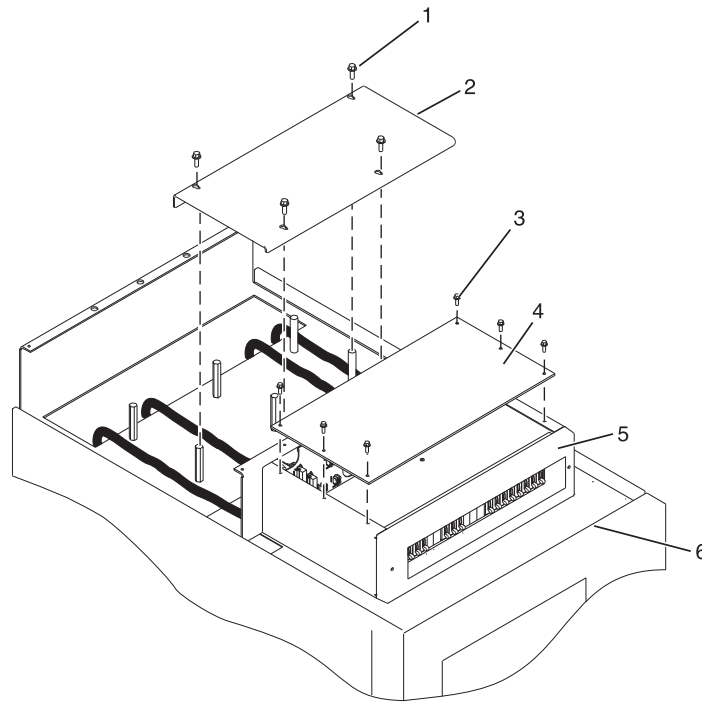

- | | |
|---|----------------------------|
| 1 Cable channel cover retaining screw | 5 Shield |
| 2 Cable channel cover | 6 Power distribution panel |
| 3 Power distribution panel top cover retaining screws | |
| 4 Power distribution panel top cover | |

Figure 14. Removing the cable channel cover

4. Remove the -48 V dc bus bar shield from the power distribution panel.

Attention: The bus bar shield must be correctly reinstalled over the -48 V dc return bus bars to protect against injury while servicing the power distribution panel.

5. Ensure that the following steps are performed when connecting the dc power source.
 - a. At -48 V dc power source, turn off any -48 V dc power sources that will be connected to the power distribution panel.
 - b. After the -48 V dc power sources are turned off, be sure there is a tag or label over the power source switches or fuses (lock-out/tag-out) to indicate that the power source is turned off intentionally.

Note: Ensure that any oxidation on the copper bus bars is removed.

- c. If this is a raised-floor installation and you are working at the back of the rack, route the power cables up the rack's right side.
- d. Ensure that the external -48 V dc power cable is connected correctly to the -48 V dc bus bar.
- e. Ensure that the external -48 V dc return cable is routed correctly and installed on the return bus bar.

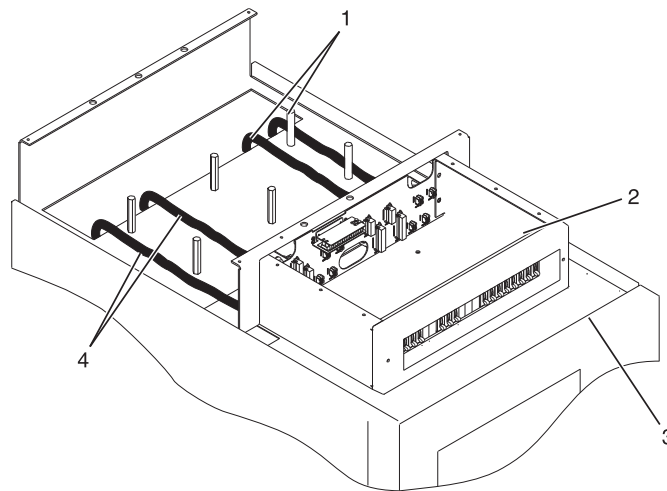

- 1 -48 V dc power cable and return power cable
- 2 Power distribution panel
- 3 Front of rack
- 4 -48 V dc power cable and return power cable

Figure 15. Routing the power cables

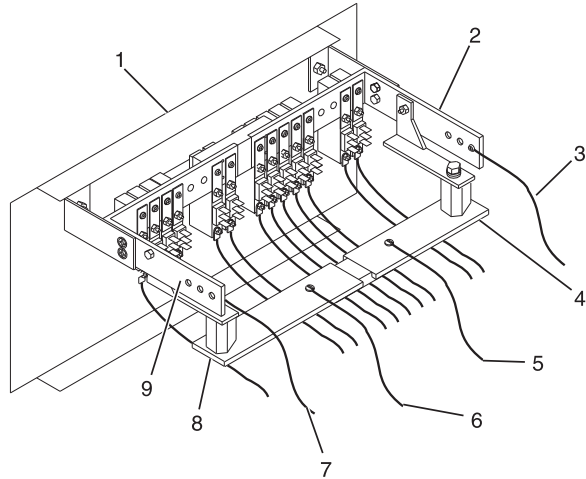

- | | |
|-------------------------------------|--------------------------------|
| 1 Front of power distribution panel | 6 (B) Return (-) power cable |
| 2 (A) -48 V dc (-) bus bar | 7 (B) -48 V dc (-) power cable |
| 3 (A) -48 V dc (-) power cable | 8 (B) Return (-) bus bar |
| 4 (A) Return (-) bus bar | 9 (B) -48 V dc (-) bus bar |
| 5 (A) Return (-) power cable | |

Figure 16. Return bus bar

- f. If you want to install a power status alarm, connect the alarm cable to the terminal board on the back cover of the dc power distribution panel.

Note: Ensure that you remove the oxidation on the copper bus bars.

- g. Ensure that the power-source ground cable is routed correctly and connects the power-source ground cable to the copper bar at the lower-back or upper-back center of the rack.
- h. If the rack is on a raised floor, attach the -48 V dc power source cables to the back of the rack with cable-restraint straps.

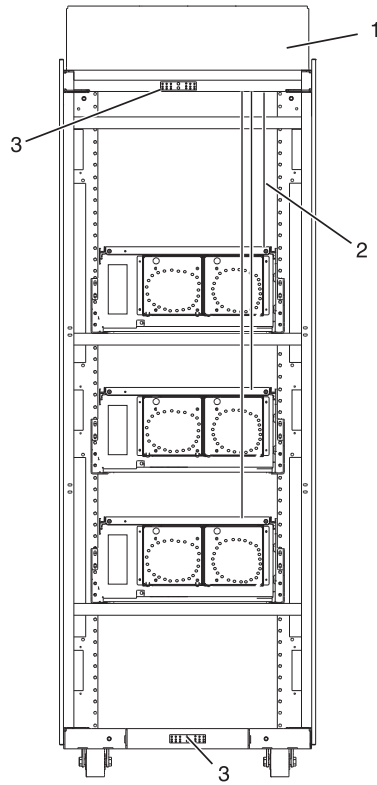

- 1 Back view of rack (dc)
- 2 Power cable, power return cable, and ground
- 3 Ground cable (Install at either top or bottom of the rack)

Figure 17. Cable locations

- 6. Reinstall the -48 V dc bus bar shield.
- 7. Reinstall the top cover on the dc power distribution panel.
- 8. Reinstall the cable channel cover.

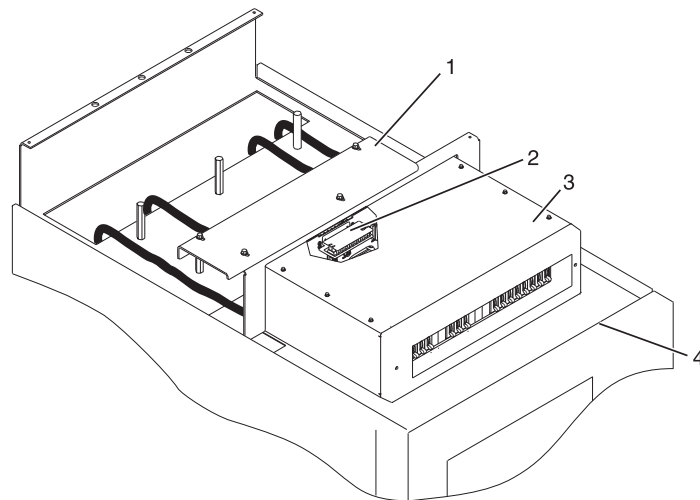

- 1 Cable channel cover

- 2 Terminal block (both sides)
- 3 Power distribution panel
- 4 Front of rack

Figure 18. Reinstalling the cable channel cover

Chapter 4. Installing a system or expansion unit into a rack

You might need to install a system or expansion unit into a rack. In addition to important related safety information, this section provides procedures that you can follow to perform these tasks. This section also includes illustrations of the related hardware components and shows how these components relate to each other.

The following procedures describe how to install system units or expansion units into a rack. You can perform this task or contact a service provider to perform the task for you. You might be charged a fee by the service provider for this service.

Installing the model 8233-E8B, 8236-E8C, 9117-MMB, or 9179-MHB into a rack

You might need to install the system into a rack. Use the procedure in this section to perform this task. In addition to information intended to promote safety and reliable operation, this section also includes illustrations of the related hardware components and shows how these components relate to each other.

This is a customer task. You can perform this task yourself, or contact a service provider to perform the task for you. You might be charged a fee by the service provider for this service.

Important: To complete this procedure, it is suggested that you use two people to attach the rail assembly to the rack, one in front of the rack and one at the back of the rack. You will need three people to lift the system unit onto the rack.

This procedure assumes that you are installing the system into an existing rack. If the rack is not installed, go to the instructions for Chapter 3, "Installing the rack," on page 5 and then return to this procedure for instructions on installing the system unit in a rack.

Note: This procedure applies only to the models that are designed to be mounted in a rack. Do not attempt to install a stand-alone model in a rack.

To install the model 8233-E8B, 8236-E8C, 9117-MMB, or 9179-MHB into a rack, complete the following steps:

CAUTION:

Installing the rails in the rack is a complex procedure. To install the rails correctly, you must perform each task in the following order. Failure to do so might cause rail failure and potential danger to yourself and the system unit.

1. Read the "Rack safety notices" on page 80.
2. If you have not already done so, refer to Figure 19 on page 28 and complete a parts inventory.

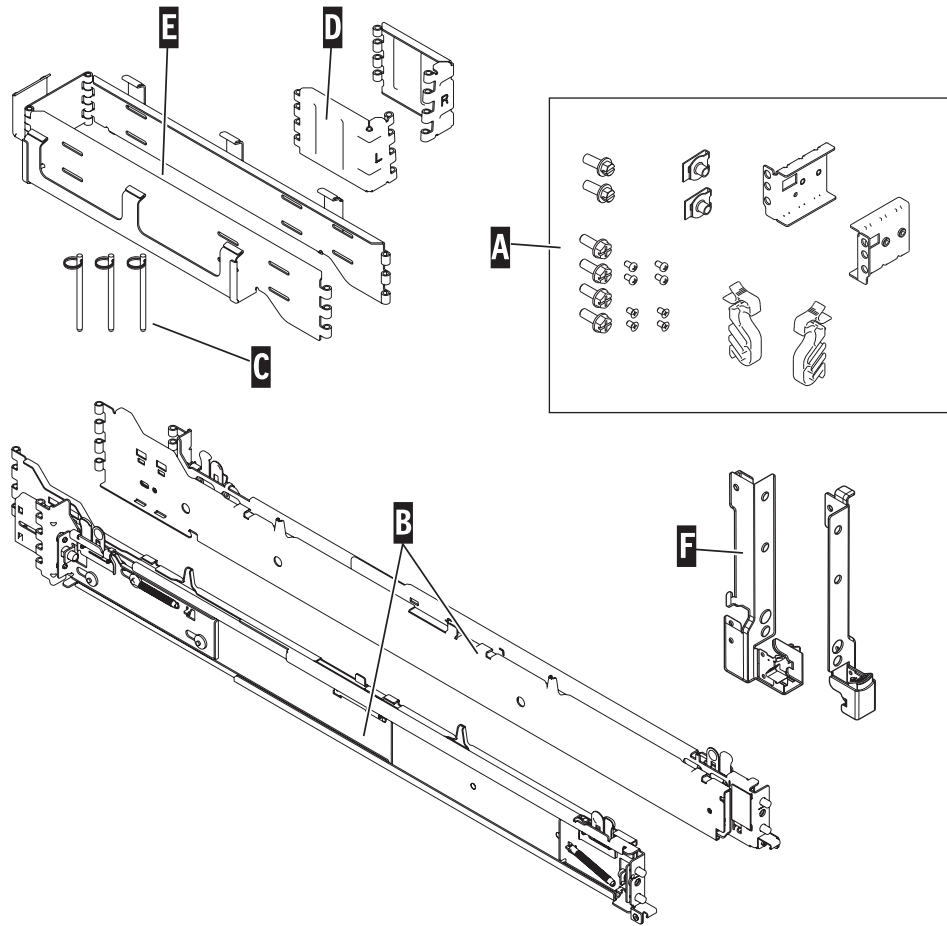

AREBW508-1

Figure 19. Rack-mounting kit

- **A** Rack-mounting hardware kit
 - Four large retaining screws
 - Two medium-sized screws
 - Two nut clips
 - Eight small retaining screws
 - Two rail support brackets
 - Two cable-restraint brackets
- **B** Left and right rack rails with rack brackets
- **C** Cable-management arm pins
- **D** Two cable-management arm brackets (one for left-side installation, one for right-side installation)
- **E** Cable-management arm
- **F** Two rack latches

If there are incorrect, missing, or damaged parts, contact:

- Your IBM reseller
- IBM Rochester Manufacturing Automated Information Line at 1-800-300-8751 (United States only)
- Directory of worldwide contacts Web site at <http://www.ibm.com/planetwide>  (Locate your service and support telephone numbers.)

3. Locate the rack-mounting hardware kit **(A)**, and the rack rails **(B)** that were included with your system unit as shown in Figure 19 on page 28.

The system rails **(B)** are front-to-back and left-to-right side dependent. The rails are labeled left and right to indicate their placement when you face the front of the rack. The back of each rail has two large latch assemblies. These latch assemblies go in the back of the rack.

4. Determine where you will locate the system unit in the rack. See “Determining the location.”
5. Next, you must attach mounting hardware to the rack. For more information, see Attach the mounting hardware to the rack.

Determining the location

You might need to determine where to install the system in the rack. Use this procedure to perform this task.

Before installing the system unit into a rack, complete the following steps:

1. Read the “Rack safety notices” on page 80.
2. Plan where to place the units. Place the larger and heavier units in the lower part of the rack.
This system unit is four Electronic Industries Alliance (EIA) units high. An EIA unit is 1.75 in. (44.45 mm) in height. The rack contains three mounting holes for each EIA unit of height. This system unit therefore is 7 in. (177.8 mm) high and covers 12 mounting holes in the rack.
3. If necessary, remove the filler panels to allow access to the inside of the rack enclosure where you plan to place the unit.

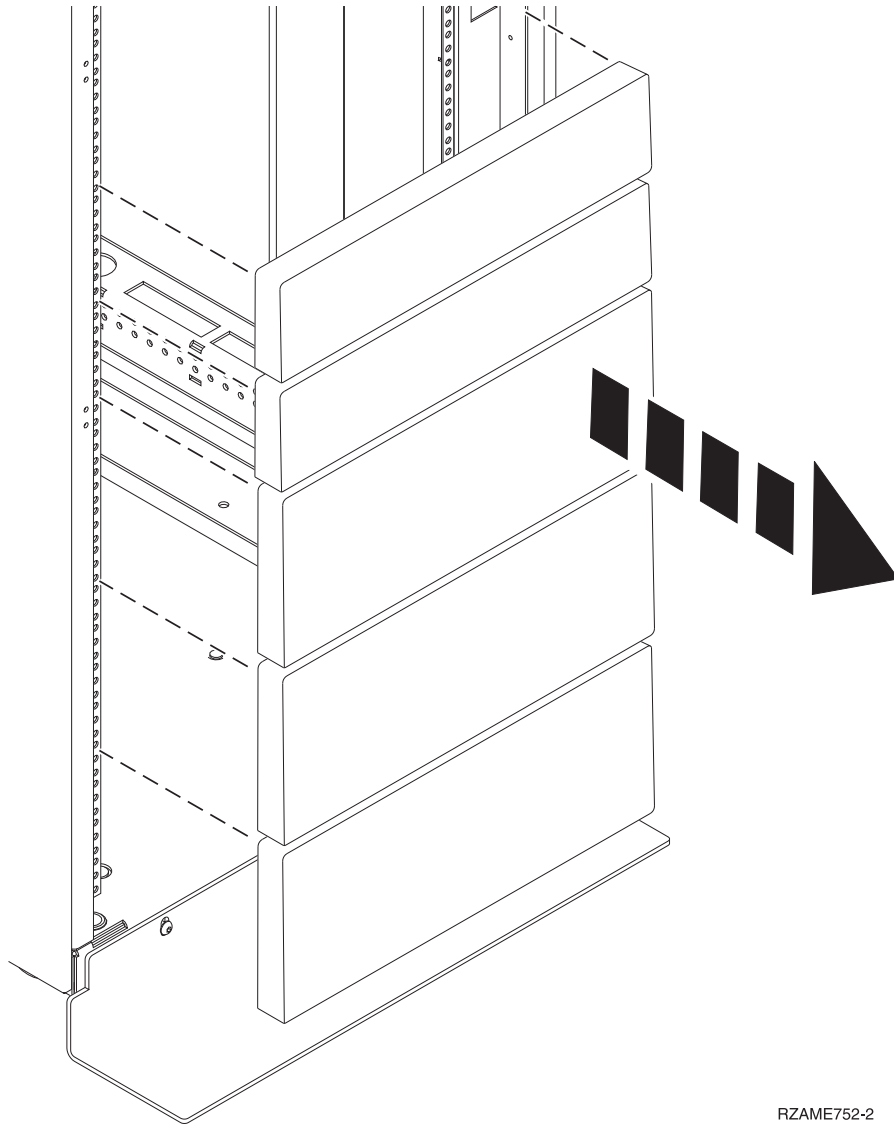

RZAME752-2

Figure 20. Removing the filler panels

4. If necessary, remove the front and back rack doors.

Marking the location

You might need to mark the installation location. Use this procedure to perform this task.

To mark the installation location and install the nut clips into a rack, complete the following steps:

1. Determine where in the rack to place the system. Install units in the lower part of the rack first. Place larger and heavier units in the lower part of the rack. Record the EIA location. The system is four Electronic Industries Alliance (EIA) units high. An EIA unit is 1.75 in. (44.45 mm) in height. The rack contains three mounting holes for each EIA unit of height. This system therefore is 7 in (177.8 mm) high and covers 12 mounting holes in the rack.
2. Face the front of the rack and work from the right side. Use tape, a marker, or a pencil to mark the holes. Mark the middle hole **A** of the bottom EIA unit of the four EIA units that you are using for this system unit. You need to identify the marked hole from both the front and back of the rack.

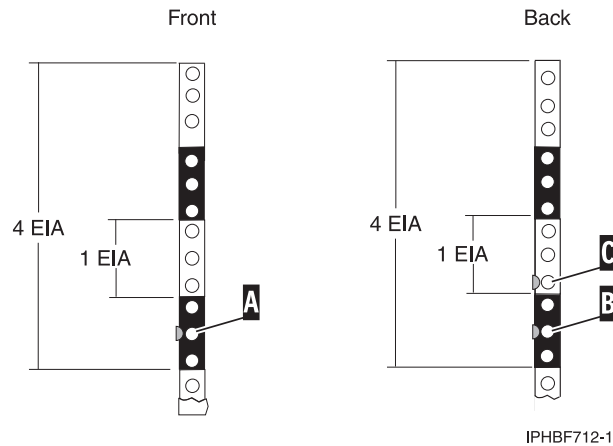

Figure 21. Marking holes on the front and back of the rack frame

3. Mark the middle hole of the bottom EIA unit on the left side of the rack (**A**) as shown in Figure 21.
4. Go to the back of the rack. On the right side, find the EIA unit that corresponds to the bottom EIA unit marked on the front of the rack.
5. Mark the middle hole of the bottom EIA unit (**B**) as shown in Figure 21.
6. Mark the bottom hole of the next (higher) EIA unit (**C**) as shown in Figure 21.
7. Mark the corresponding holes on the left side of the rack.

Attaching the 8233-E8B and 8236-E8C mounting hardware to the rack

You might need to attach the mounting hardware to the rack. Use the procedure in this section to perform this task. The information provided is intended to promote safety and reliable operation. This section also includes illustrations of the related hardware components and shows how these components relate to each other.

Attention: To avoid rail failure and potential danger to yourself and to the unit, ensure that you have the correct rails and fittings for your rack. If your rack has square support flange holes or screw-thread support flange holes, ensure that the rails and fittings match the support flange holes used on your rack. Do not install mismatched hardware using washers or spacers. If you do not have the correct rails and fittings for your rack, contact your IBM reseller. Also, to install the rails correctly, perform each task in the following order.

To install the rack-mounting hardware into the rack, complete the following steps:

1. With the right rail, twist the latch assembly release tab (**A**) in Figure 22 on page 32. Slide release tab (**B**) back to the retracted position and lock the latch assembly. The back-alignment pins must be fully retracted.
2. After the alignment pins are retracted, insert the right side rail front-alignment pin, as shown in Figure 22 on page 32, into the rack front flange hole. This hole is identified by the mark that you previously made. Have a second person hold the rail securely in the front hole.

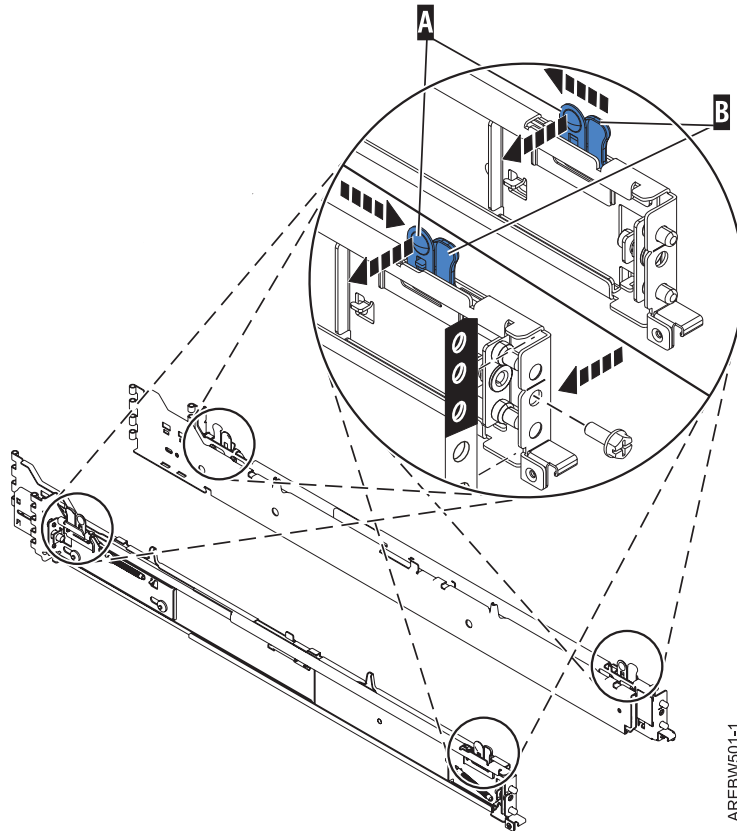
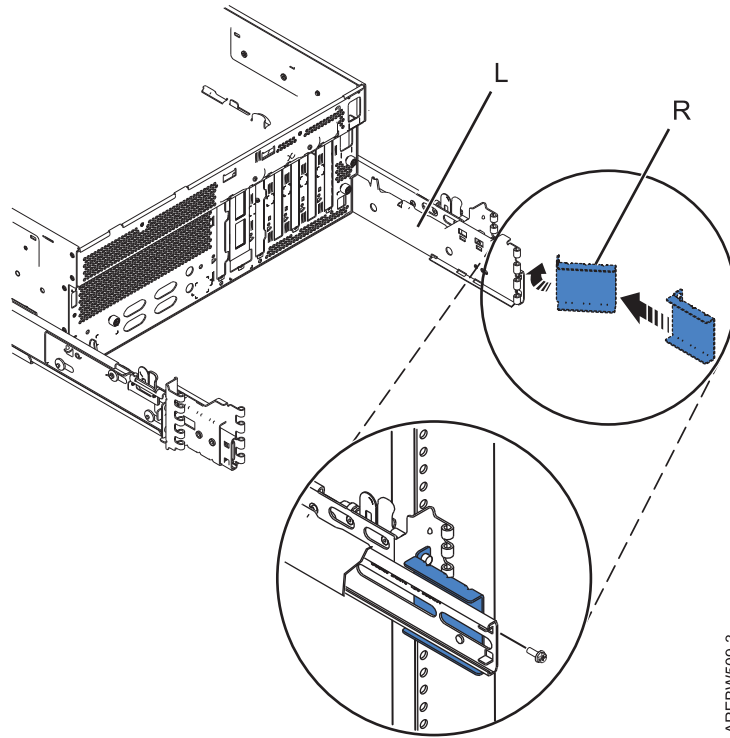

Figure 22. Front slide rail alignment pin, retaining screws, and latch bracket

3. Align the back-alignment pins of the rail with the holes at the back of the rack. The holes are identified by the marks on the back of the rack. Ensure that the rails are level.
4. Slide the release tab **(B)** to extend the two back-alignment pins into the back of the rack. Ensure that the pins have passed through the correct holes in the rack frame.
5. From the back of the rack, as shown in Figure 23 on page 33, install the rail support bracket on the alignment pins. Then insert a large rail-retaining screw into the hole located between the two back alignment pins. Partially tighten the screw. Do not tighten completely at this time.

Note: The brackets are labeled LEFT and RIGHT.



AREBW509-3

Figure 23. Installing the rail support brackets

6. Repeat steps 1 on page 31 through 5 on page 32 for the left side rail.
7. Locate the two latch brackets (F) in Figure 19 on page 28. To install the rack latches, use the following procedure:
 - a. Rotate the top of the bracket out as shown in Figure 24 on page 34.

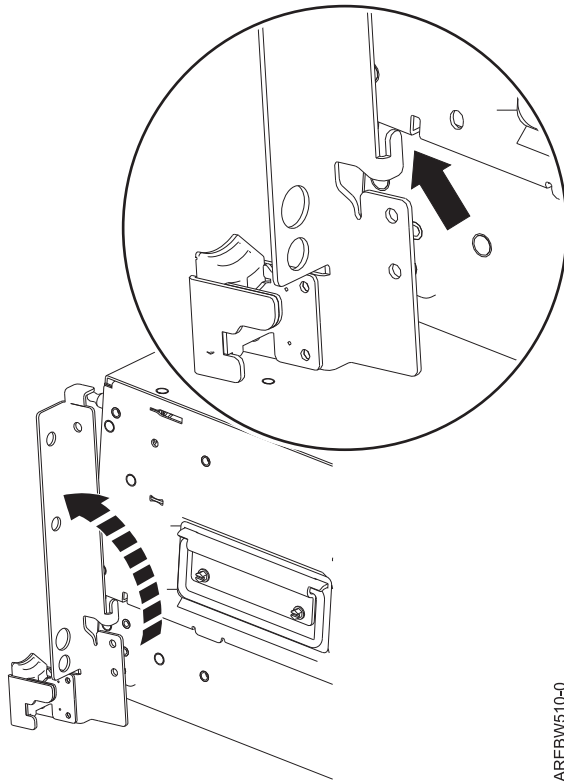

AREBW510-0

Figure 24. Rotate out the top of the bracket

- b. Align the bracket with the slot on the side of the system as shown in Figure 25 on page 35.

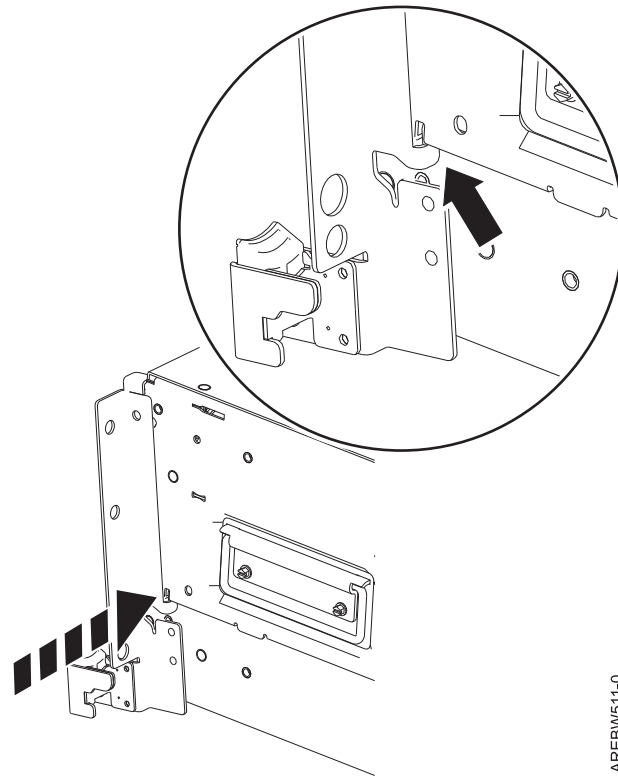

Figure 25. Align the bracket with the slot on the side of the system

- c. Move the bracket up to engage the tab as shown in Figure 26.

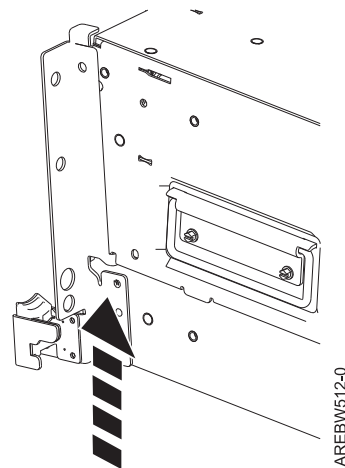

Figure 26. Move the bracket up to engage the tab

- d. Rotate the top of the bracket back so that the top tab is on top of the system. Then install the screws as shown in Figure 27 on page 36.

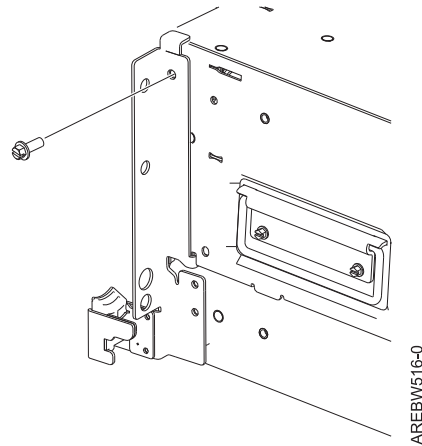

Figure 27. Rotate the top of the bracket back so that the top tab is on top of the system

8. Extend the inner rails by pulling out the rails. They must be extended from the frame like the rails shown in Figure 28.
9. Using three people, grasp the two handles located on each side of the system, and place the system onto the inner rail. Align tab **A** with slot **B** as indicated by the vertical dashed line shown in Figure 28.

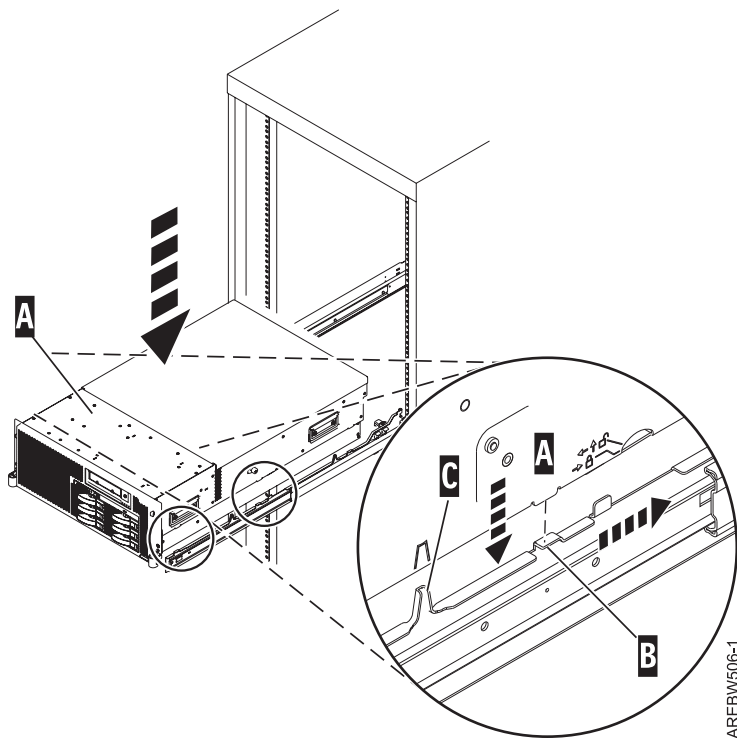
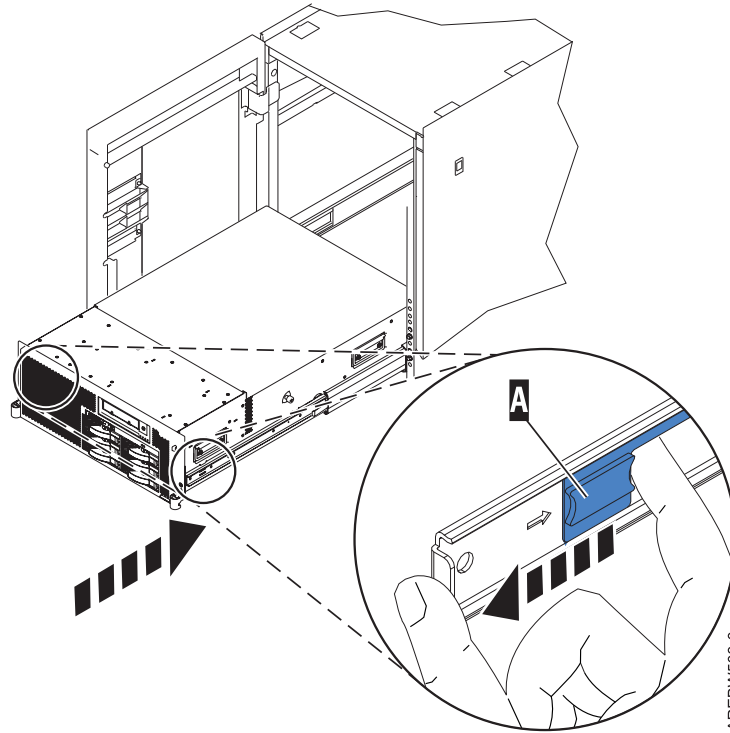

Figure 28. Place system onto the rails

10. Simultaneously press the safety latches and push the system into the rack until it locks as shown in Figure 29 on page 37.



AREBW603-0

Figure 29. Inner rail extended

11. Install and position the nut clips before inserting the screws. Use the retaining screws to attach the system to the rack as shown in Figure 30 on page 38.

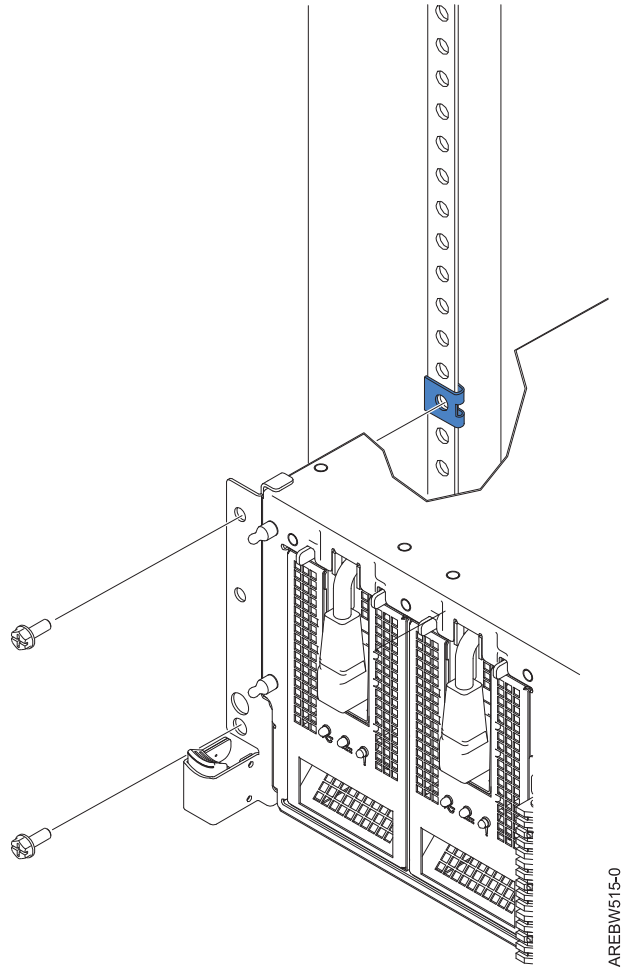

Figure 30. Secure system to rack through rack latches

12. After both rails have been installed, ensure that none of the rail retaining screws are more than finger tight. The rails must be level from front to back and from left to right.
13. Next, you must install the cable-management arm. For more information, see “Installing the cable-management arm.”

Installing the cable-management arm

You might need to install the cable-management arm. Use this procedure to perform this task.

To install the cable-management arm, complete the following steps:

1. Determine on which side of the rack you want to install the cable-management arm.
2. Place the correct arm bracket (Left or Right) with the cable-management arm.
3. Use the pin (F) to pin the cable-management arm (E) to the rack frame (D) as shown in Figure 31 on page 39.

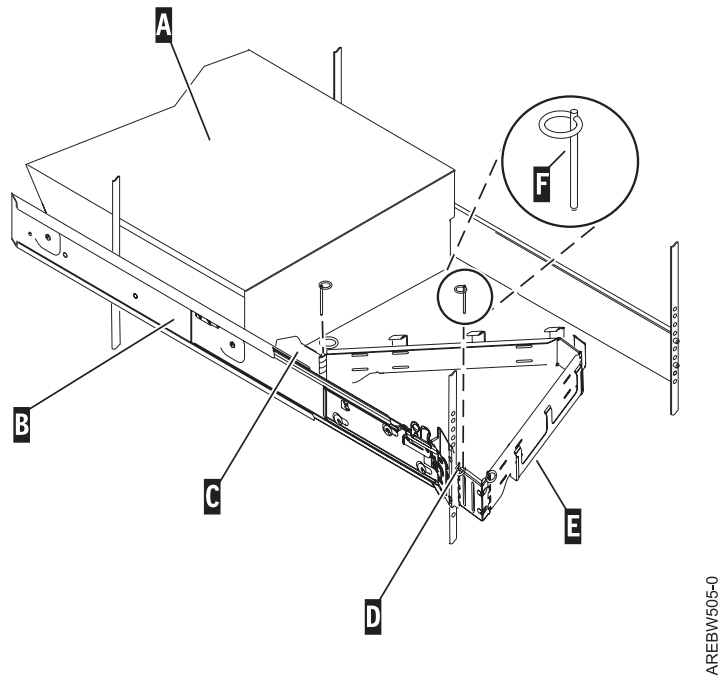

Figure 31. Attaching the cable-management arm.

Tip: If access to the back of the rack is obscured by many existing cables, it might be easier to remove the small connecting hinge from the cable-management arm and attach it first. Then, you can attach the remaining section of the cable-management arm to the connecting hinge.

4. Use the second pin (F) to pin the other end of the cable-management arm to the flange (C) that is attached to the sliding portion of the left system rail assembly (B) as shown in Figure 31.

Connecting the power cables to the system

You might need to connect power cables to the system. Use this procedure to perform this task.

To connect power cables to the system, follow these steps:

1. While facing the rear of the system unit, note the bottom tab of the cable-restraint bracket. Turn the cable-restraint bracket counter-clockwise to a horizontal position, and insert the bottom tab of the cable-restraint bracket into the bottom hole in the rail. Then rotate the cable-restraint bracket clockwise to the vertical position as shown in Figure 32 on page 40. Insert the system power cord through the cable-restraint bracket as shown in this figure. Then press down on the top of the bracket and insert the top tab into the top hole.

Note: There are two sets of holes on the rail where the cable-restraint bracket can be installed. These sets of holes are about 25.4 mm (1 inch) apart. Install the bracket in the rear most set of holes.

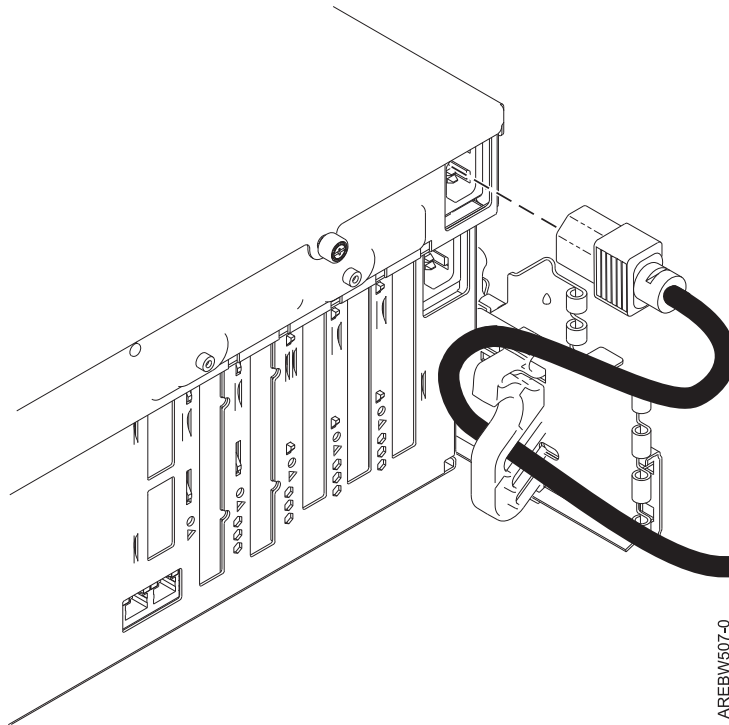

Figure 32. Routing system power cord

2. Plug the power cord into the system unit.

Note: If the system is equipped with two power supplies, each must have its own power cord plugged in.

3. Plug the system power cord and the power cords for any printers or displays into the alternating current (AC) power source.
4. Power on the system unit and any devices connected to the system unit.

For instructions on how to connect and configure the expansion unit after installation, see Enclosures and expansion units.

Installing the model 5802 or 5877 into a rack

This procedure can be used to install the 5802 or 5877 disk drive enclosure into a rack. The procedure includes information intended to promote safety and reliable operation, and provides illustrations on how hardware components relate to each other.

- This procedure assumes that you are installing the 5796 or 7314-G30 expansion unit into an existing rack. If the rack is not installed, you must perform the procedure for Chapter 3, “Installing the rack,” on page 5 before performing this procedure to install the expansion unit into the rack.

Note: This procedure applies only to the models that are designed to be mounted in a rack. Do not attempt to install a stand-alone model in a rack.

- Read the “Rack safety notices” on page 80.
- For instructions related to installing, removing, and replacing a disk drive, disk-drive backplane, or enclosure, see Disk drives.

To install the model 5802 or 5877 into a rack, complete these steps:

CAUTION:

Installing the rails in the rack is a complex procedure. To install the rails correctly, you must perform each task in the following order. Failure to do so might cause rail failure and potential danger to yourself and the system unit.

Attention: Installing the rails in the rack is a complex procedure. To install the rails correctly, you must perform each task in order. Failure to do so might cause rail failure and potential danger to yourself and the expansion unit. Also, note that for the 5802 and 5877, three people are required to safely lift the system. Using fewer than three people to lift the system can result in injury.

1. Complete a parts inventory. Refer to the kitting list provided with the rack installation kit, and see “Completing a parts inventory” on page 66.
2. Locate the rack-mounting hardware kit and the system rail assemblies that were included with your expansion unit.
3. Determine where to locate the expansion unit in the rack. See “Determining the location.” This expansion unit is four Electronic Industries Alliance (EIA) units high. An EIA unit is 1.75 in (44.45 mm) in height. The rack contains three mounting holes for each EIA unit of height.
4. Mark the location. See “Marking the location” on page 42.

Determining the location

You might need to determine where to install an expansion unit in the rack. Use this procedure to perform this task.

Before installing the expansion unit into a rack, complete the following steps:

1. Determine where in the rack to place the expansion unit in relation to other system hardware. As you prepare, organize larger and heavier units into the lower part of the rack, and plan to install units into the lower part of the rack first. Record the EIA locations in your plan.

Note: These expansion units are four Electronic Industries Alliance (EIA) units high. An EIA unit is 1.75 in. (44.50 mm) in height. The rack contains three mounting holes for each EIA unit of height. This system unit, therefore, is 7 in. (177.8 mm) high and covers 12 mounting holes in the rack.

2. If necessary, remove the filler panels to allow access to the inside of the rack enclosure where you plan to place the expansion unit.

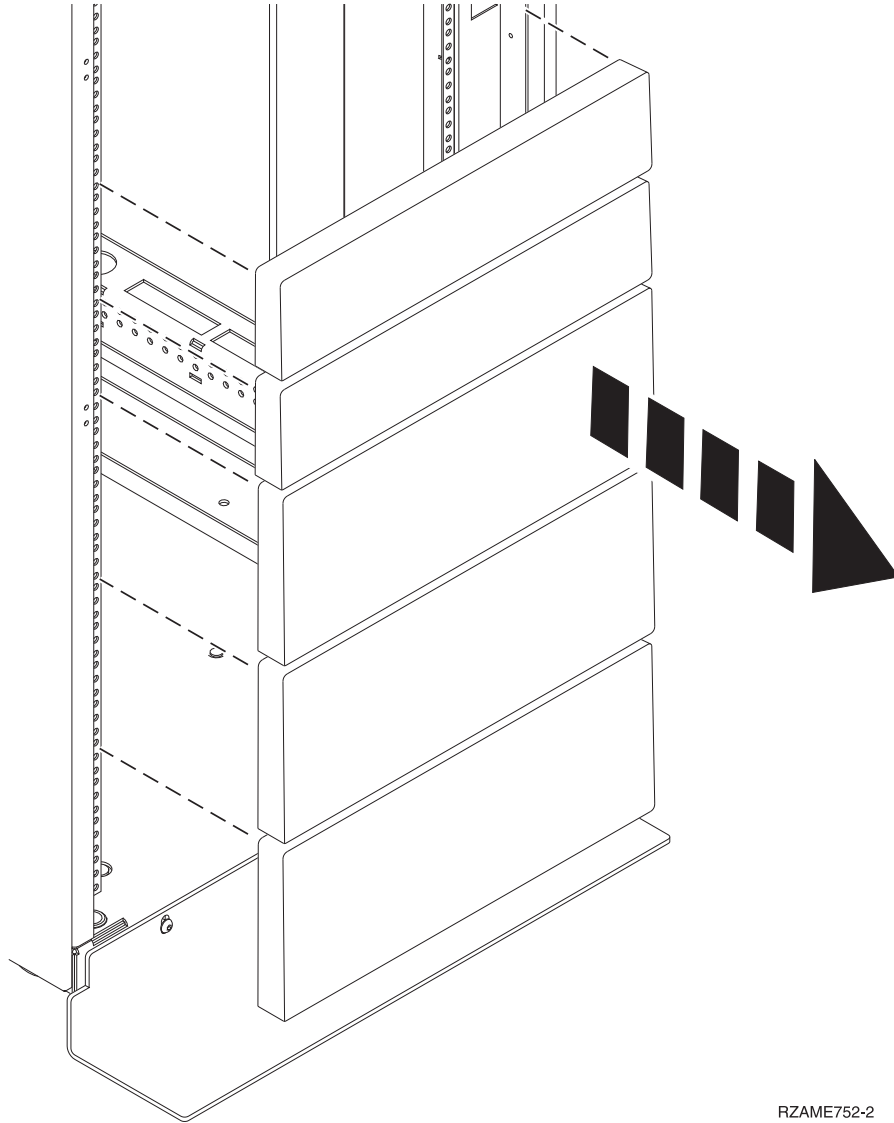

RZAME752-2

Figure 33. Removing the filler panels

3. If necessary, remove the front and back rack doors.
4. Mark the location where you intend to install the disk drive enclosure.
 - a. If you have a rack-mounting template, use it to mark the location.
 - b. If you do not have a rack-mounting template, see “Marking the location.”

Marking the location

You might need to mark the installation location. Use the procedure in this section to perform this task.

To mark the installation location and the position for installing the nut clips into a rack, complete these steps:

1. Determine where in the rack to place the expansion unit in relation to other system hardware. As you plan, keep the following in mind:
 - a. Organize larger and heavier units into the lower part of the rack.
 - b. Plan to install units into the lower part of the rack first.
 - c. Record the EIA locations in your plan.

Note: These expansion units are four Electronic Industries Alliance (EIA) units high. An EIA unit is 1.75 in. (44.50 mm) in height. The rack contains three mounting holes for each EIA unit of height. This system unit, therefore, is 7 in. (177.8 mm) high and covers 12 mounting holes in the rack.

2. Face the front of the rack and work from the left side. Make a note of both the lowest and highest EIA units to be used for the expansion unit. Use tape, a marker, or pencil to mark the bottom mounting hole (**A**) of the highest EIA unit. Then mark the top mounting hole (**B**) of the lowest EIA unit. Mark the rack so that the mark can also be seen from the rear of the rack.

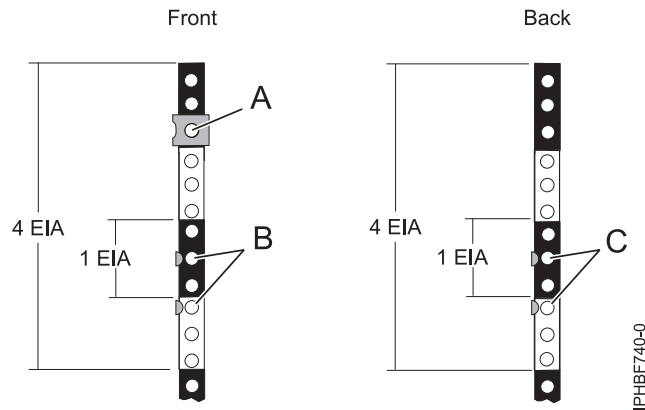

Figure 34. Marking the installation locations

3. On the left rail, count up two mounting holes from where you placed the mark for mounting hole (**B**) in step “Marking the location” on page 42 and place another mark next to that mounting hole (**B**). Mark the rack so that the mark can also be seen from the rear of the rack. You now have two (**B**) marks on the rack, with one mounting hole between the marks.
4. Repeat steps 2 and 3 to place three marks on the corresponding mounting holes on the front-right rail.
5. Go to the back of the rack. On the left side, find the EIA unit that corresponds to the lowest EIA unit marked on the front of the rack.
6. Place a mark at the top hole (**C**) of the lowest EIA unit. Mark the rack so that the mark can be seen from the rear of the rack.
7. Count up two mounting holes from where you placed the mark in step 6 and place another mark next to that mounting hole (**C**).
8. Repeat steps 6 and 7 to place two marks on the corresponding mounting holes on the rear-right rail.

Attaching the mounting hardware to the rack

You might need to attach mounting hardware to the rack. Use the procedure in this section to perform this task. This section also includes information intended to promote safety and reliable operation, and illustrations of the hardware components.

CAUTION:

Installing the rails in the rack is a complex procedure. To install the rails correctly, you must perform each task in the following order. Failure to do so might cause rail failure and potential danger to yourself and the system unit.

To install the mounting hardware into the rack, follow these steps:

1. Rotate down the front and back clamps (**C**) on the left and right rails.
2. On each rail, remove the tape holding the spring (**B**) to the rail. Hook the end of the spring around the circular standoff on the rail.

3. Start at the front of the rack. Extend the right rail and insert the rail pins (D) into the marked locations in the rack so that the rail is facing upward. Rotate up the front clamp (C) to secure the rail in place.

Notes:

- If your rack has the square mounting holes, remove the rail pins (D) from the rail. Install the larger rail pins provided with the rack installation kit.
- The rail installation can be completed by one person. However, the installation is easier if one person is positioned at the front of the rack and one person is positioned at the back of the rack.

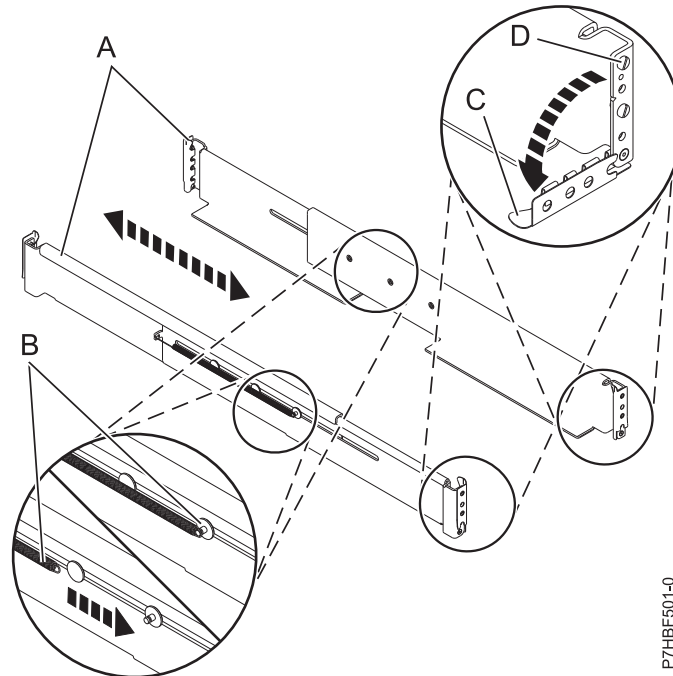

Figure 35. Installing the rails

4. Extend the left rail and insert the rail pins (D) into the marked locations. Rotate up the front clamp (C) to secure the rail in place.
5. Move to the back of the rack, extend the right rail, and insert the rail pins (D) into the marked locations. Rotate up the back clamp (C) to secure the rail in place.
6. Extend the left rail and insert the rail pins (D) into the marked locations. Rotate up the back clamp (C) to secure the rail in place.
7. At the back of the rack, use two M5 screws (E), one below each rail pin (D), to secure the left rail to the back of the rack.
8. Use two M5 screws (E), one below each rail pin (D), to secure the right rail to the back of the rack.
9. Move to the front of the rack. Use one M5 screw (E) below the top rail pin to secure the left rail to the front of the rack.

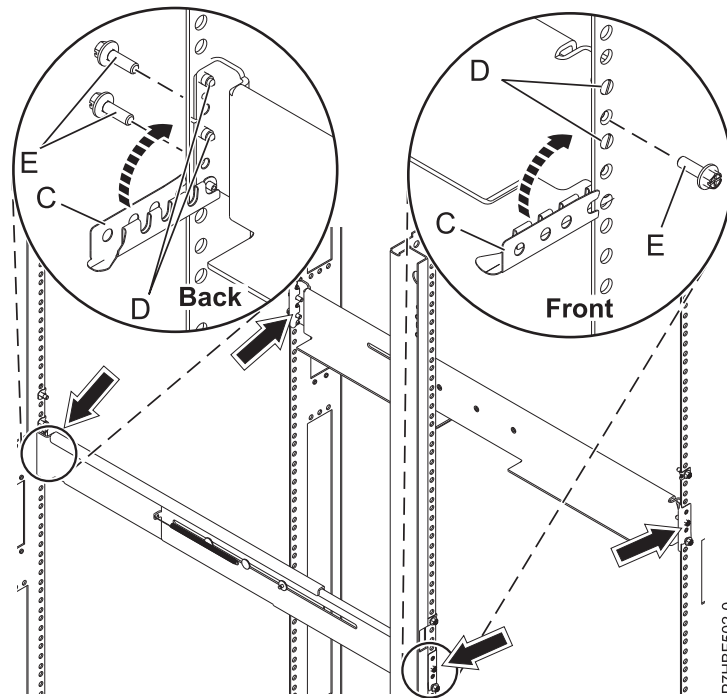

Figure 36. Attaching the rails

10. Use one M5 screw (E), below the top rail pin (D), to secure the right rail to the front of the rack.
11. Insert one nut clip at the marked location (A) on the front-left rail.
12. Insert one nut clip at the marked location (A) on the front-right rail.
13. Insert one nut clip (F) on the right side of the rack as shown in Figure 37 on page 46.
14. Insert one nut clip (F) on the left side of the rack as shown in Figure 37 on page 46.
15. From the back of the rack, insert two nut clips (F) on the right side of the rack as shown in Figure 37 on page 46.

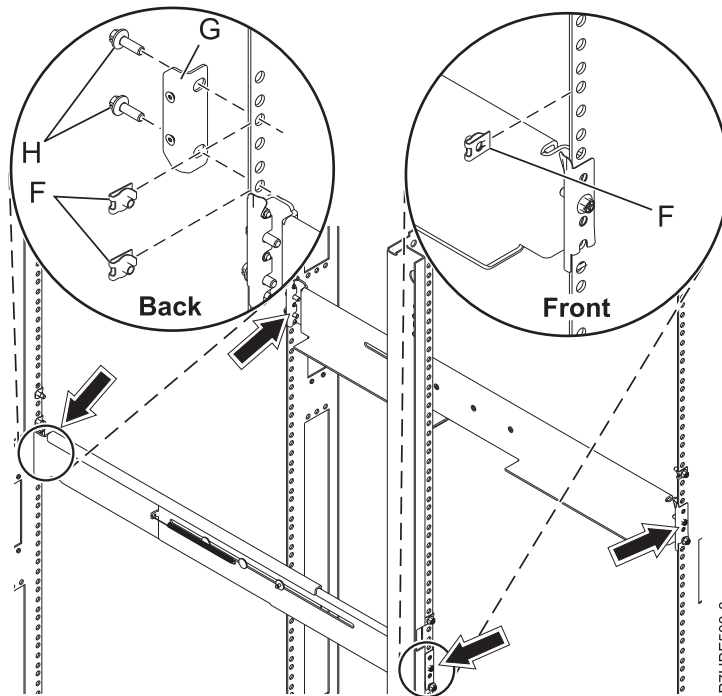

Figure 37. Installing the retention bracket

16. Use two M5 screws (H) to attach the retention bracket (G) to the rack on the right side.
17. Insert two nut clips (F) on the left side of the rack as shown in Figure 37.
18. Use two M5 screws (H) to attach the retention bracket (G) to the rack on the left side.

Note: For references to marked location (A) on the front-left rail and front-right rail, see Marking the installation locations.

Installing the 5802 or 5877 on the rail assembly

You might need to install the expansion unit on the rail assembly. Use the procedure in this section to perform this task. In addition to related safety information, this section also includes illustrations of the related hardware components and shows how these components relate to each other.

1. Before installing the expansion unit on the rail assembly, ensure that the stabilizers are extended and the tip plate is attached to the bottom front of the rack to prevent the rack from falling forward when the rails are pulled out of the rack. Refer to “Rack safety notices” on page 80.

To install the expansion unit on the rail assembly, follow these steps:

1. To remove the shipping cover from the back of the expansion unit, remove the four thumb screws that are used to secure it. Pull off the cover.

Note: There are two thumb screws at the top of the cover and one on each side.

2. If the bezel is installed on the front of the system, remove it by using these steps:
 - a. Remove the two M5 securing screws (A) as shown in Figure 38 on page 47.
 - b. Remove the service information holder from the slot in the bezel.
 - c. Using the two blue touch points on each side of the expansion unit, pull the bezel straight out to remove the bezel from the front of the expansion unit.
 - d. Remove the two nut clips that were used to secure the bezel to the expansion unit from the EIA flange.

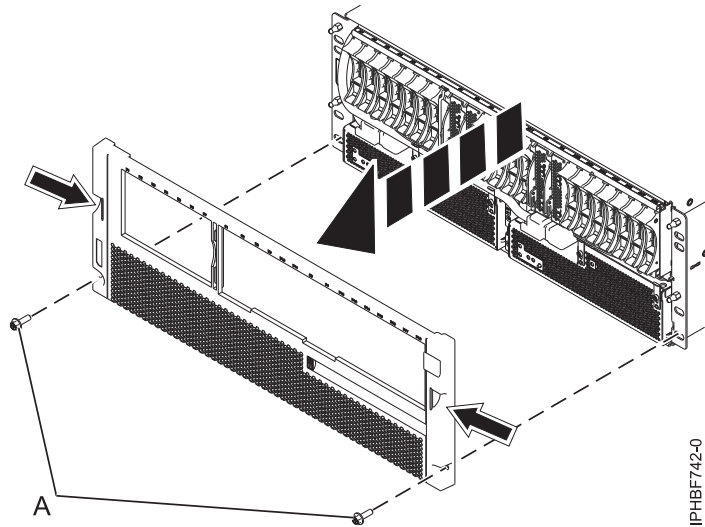

Figure 38. Removing the service information holder and bezel

- Using three people, hold onto the four handles (**I**), as shown in the following figure, to lift the expansion unit and position it over the front of the rails.

Attention: Three people are required to safely lift the expansion unit. Using fewer than three people to lift the expansion unit can result in injury.

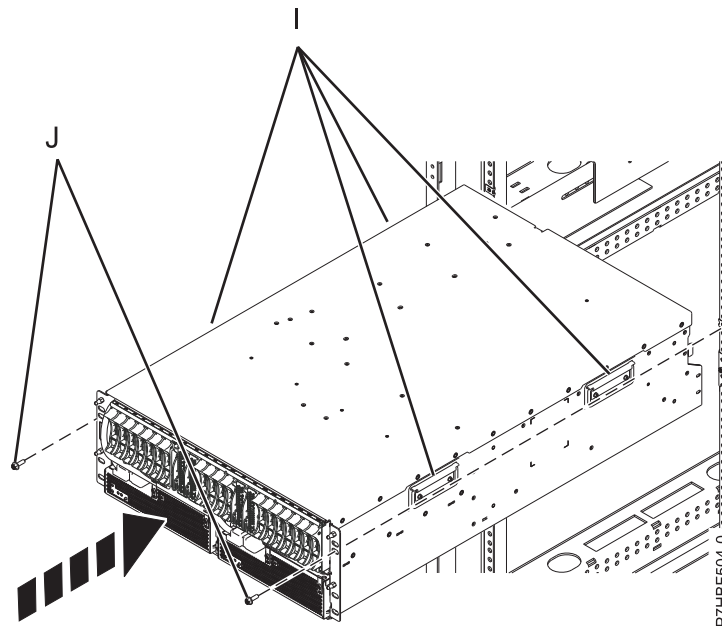

Figure 39. Installing the expansion unit into a rack

- Slide the expansion unit into the rack.
- Install the two M5 securing screws (**J**) through the expansion unit and into the nut clips on the left and right rails.
- Install the bezel (**L**) onto the expansion unit. Press the bezel into place and secure it with two M5 screws (**M**) on the left and right rails.

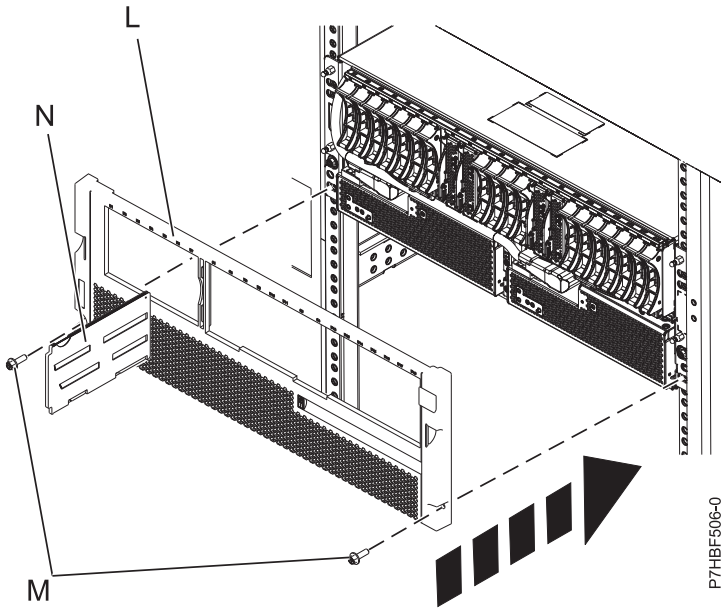
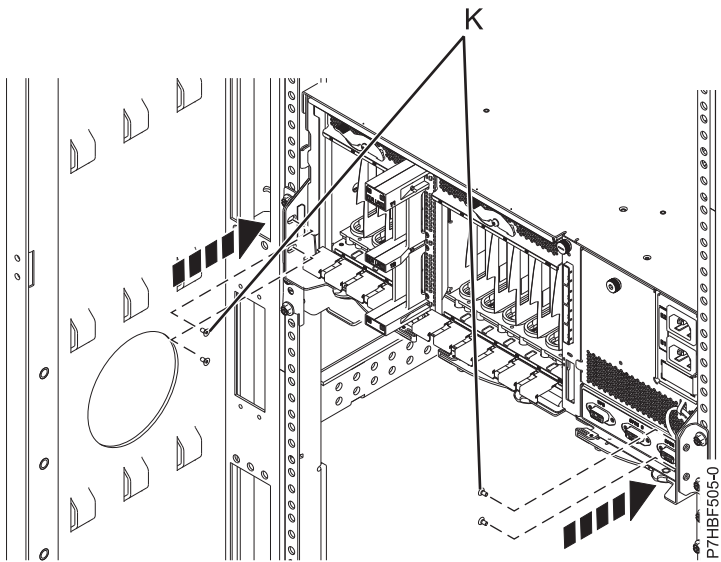

Figure 40. Installing the bezel and service information holder

7. Insert the service information holder (N) into the slot in the bezel.
8. At the back of the system, install the four securing screws (K) through the expansion unit and retention brackets on the left and right rails.



For instructions on how to connect and configure the expansion unit after installation, see Enclosures and expansion units.

Installing the model 5886 into a rack

This procedure can be used to install the 5886 disk drive enclosure into a rack. The procedure includes information intended to promote safety and reliable operation, and provides illustrations on how hardware components relate to each other.

- This procedure assumes that you are installing the 5886 disk drive enclosure into an existing rack. If the rack is not installed, you must perform the procedure for Chapter 3, “Installing the rack,” on page 5 before performing this procedure to install the disk drive enclosure into the rack.

Note: This procedure applies only to the models that are designed to be mounted in a rack. Do not attempt to install a stand-alone model in a rack.

- Read the “Rack safety notices” on page 80.

Installing the disk drive enclosure into a rack is a customer task. You can perform this task yourself, or contact a service provider to perform the task for you. You might be charged a fee by the service provider for this service.

Important: To complete this procedure, it is suggested that you use two people to attach the rail assembly to the rack. Position one person in front of the rack and one person at the back of the rack.

To install the model 5886 into a rack, complete these steps:

CAUTION:

Installing the rails in the rack is a complex procedure. To install the rails correctly, you must perform each task in the following order. Failure to do so might cause rail failure and potential danger to yourself and the system unit.

1. Complete a parts inventory, if you have not done so.

Note: For this installation you will need a 5 mm (3/16-in.) flat-blade screwdriver during the installation. A #2 Phillips screwdriver and an 8 mm wrench are optional.

Here is a list of items that you need to install the unit in the rack cabinet:

- Rail assembly, right (1)
- Rail assembly, left (1)
- M5 screws (8)
- Small diameter spacers (8) (these come installed, four in each rail)
- Large diameter spacers (8)

Note: These are used with square mount racks only.

- M4 pan-head screws (2)
- 15 mm (0.60 in.) diameter washers (6)

Note: These are used with square mount racks only.

If there are incorrect, missing, or damaged parts, contact:

- Your IBM reseller
 - IBM Rochester Manufacturing Automated Information Line at 1-800-300-8751 (United States only)
 - Directory of worldwide contacts Web site at <http://www.ibm.com/planetwide>  (Locate your service and support telephone numbers.)
2. Locate the rack-mounting hardware kit and the system rail assemblies that were included with your disk drive enclosure.
The rails are front-to-back and left-to-right side dependent.
 3. Determine where you will locate the disk drive enclosure in the rack. See “Determining the location” on page 50.

Determining the location

You might need to determine where to install the disk drive enclosure into the rack. Follow this procedure to perform this task.

Read the “Rack safety notices” on page 80.

Before installing the disk drive enclosure into a rack, complete the following steps:

1. Determine where in the rack to place the disk drive enclosure in relation to other system hardware. As you plan, keep the following in mind:
 - a. Organize larger and heavier units into the lower part of the rack.
 - b. Plan to install units into the lower part of the rack first.
 - c. Record the EIA locations in your plan.

Note: The 5886 disk drive enclosure is two Electronic Industries Alliance (EIA) units high. An EIA unit is 1.75 in. (44.50 mm) in height. The rack contains three mounting holes for each EIA unit of height. This system unit, therefore, is 3.5 in. (89 mm) high and covers 6 mounting holes in the rack.

2. If necessary, remove the filler panels to allow access to the inside of the rack enclosure where you plan to place the disk drive enclosure.

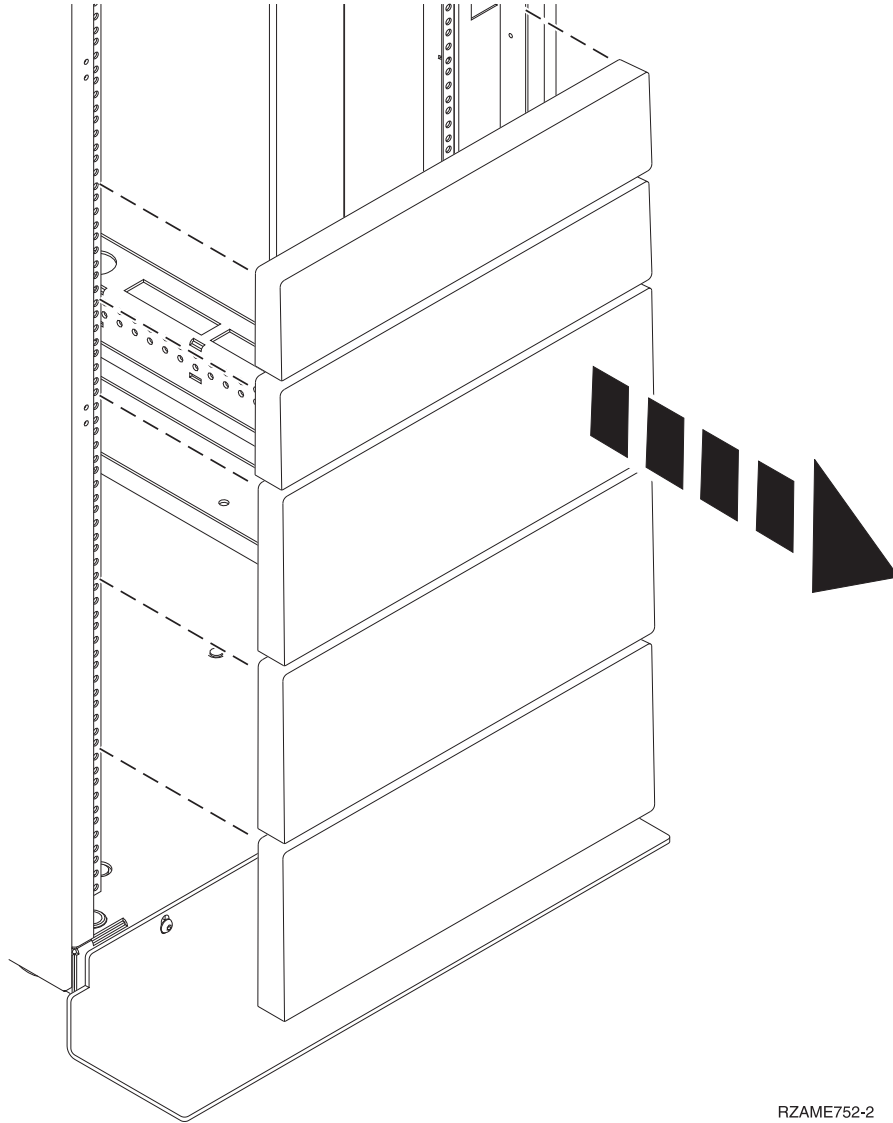

RZAME752-2

Figure 41. Removing the filler panels

3. If necessary, remove the front and back rack doors.
4. Mark the location where you intend to install the disk drive enclosure.
 - a. If you have a rack-mounting template, use it to mark the location.
 - b. If you do not have a rack-mounting template, see “Marking the location.”

Marking the location

You might need to mark the location for rack installation. Follow these steps to perform this task.

To mark the installation location and install the nut clips into a rack, complete the following steps:

1. Determine where in the rack to place the disk drive enclosure in relation to other system hardware. As you plan, keep the following in mind:
 - a. Organize larger and heavier units into the lower part of the rack.
 - b. Plan to install units into the lower part of the rack first.
 - c. Record the EIA locations in your plan.

Note: The 5886 disk drive enclosure is two Electronic Industries Alliance (EIA) units high. An EIA unit is 1.75 in. (44.50 mm) in height. The rack contains three mounting holes for each EIA unit of height. This system unit, therefore, is 3.5 in. (89 mm) high and covers 6 mounting holes in the rack.

2. Face the front of the rack and work from the right side of the rack. Mark the middle hole of the bottom EIA unit (**A**) in Figure 42. Identify the marked hole from both the front and back of the rack.
3. Mark the middle hole of the bottom EIA unit on the left side of the rack.
4. Go to the back of the rack. On the right side, find the EIA unit that corresponds to the bottom EIA unit marked on the front of the rack.

Note: The following figure is an example of how the EIA units appear, you might have a different configuration or placement.

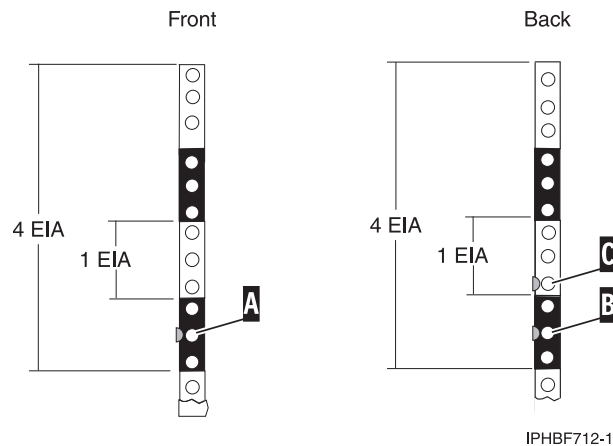

Figure 42. Marking holes on the front and back of the rack frame

5. Mark the middle hole of the bottom EIA unit. See **B** in Figure 42.
6. Mark the bottom hole of the next (higher) EIA unit. See **C** in Figure 42.
7. Mark the corresponding holes on the left side of the rack.

Attaching the mounting hardware to the rack

You might need to attach mounting hardware to the rack. Follow these steps to perform this task. In addition to information intended to promote safety and reliable operation, this section also includes illustrations of the related hardware components and shows how these components relate to each other.

CAUTION:

Installing the rails in the rack is a complex procedure. To install the rails correctly, you must perform each task in the following order. Failure to do so might cause rail failure and potential danger to yourself and the system unit.

To install the mounting hardware into the rack, follow these steps:

1. Loosen the two rail-adjustment screws on one rail just enough to enable the rails to slide.

Note: The rails are marked with an **L** or **R** on the front brackets.

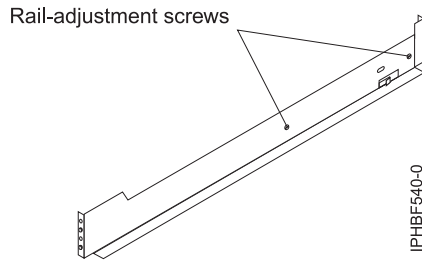
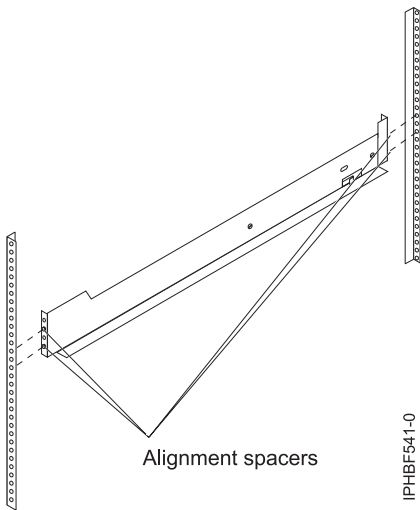

Figure 43. Extending the rails

- Align the rail with the inside of the front and rear of the rack cabinet. The bottom of the rail support ledge should be slightly above the U mark on the rack flange.

The rail comes with two spacers in the front bracket and two spacers in the rear bracket. If the rack has round holes, the spacers on the rail brackets fit into the round holes in the rack flanges. If the rack has square holes, replace the set of small spacers on the front and rear of the rail with the larger spacers that come with the rail kit.



- Secure the rail to the front of the rack cabinet with one M5 screw in the top hole of the bracket. For racks with square holes, add one washer between the M5 screw and the rail bracket.

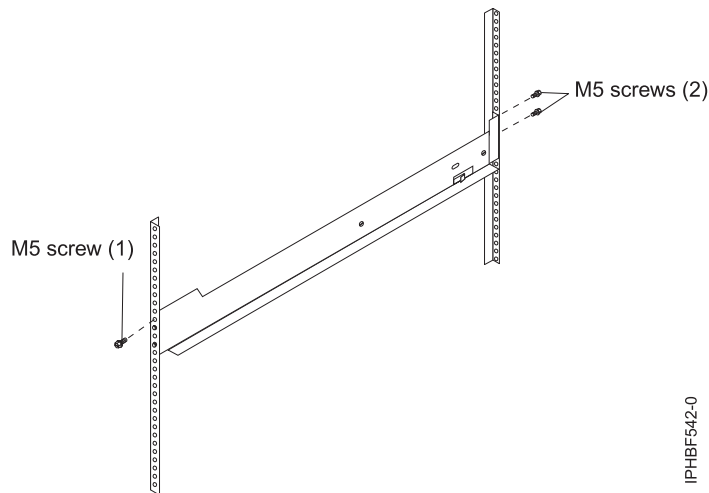

Figure 44. Attaching the rails

4. Secure the rail to the rear of the rack cabinet with two M5 screws in the top and bottom holes in the rear rail bracket. For racks with square holes, add one washer between each M5 screw and the rail bracket.
5. Tighten the rail-adjustment screws.
6. Repeat step 1 through step 5 for the other rail.

Installing the 5886 on the rail assembly

You might need to install the expansion unit on the rail assembly. Use the steps detailed in this procedure to perform this task. In addition to related safety information, illustrations of the related hardware components are provided.

1. Before installing the expansion unit on the rail assembly, ensure that the stabilizers are extended and the tip plate is attached to the bottom front of the rack to prevent the rack from falling forward when the rails are pulled out of the rack. Refer to “Rack safety notices” on page 80.

To install the disk drive enclosure on the rail assembly, follow these steps:

1. To reduce the weight of the unit for easier installation in the rack cabinet, remove the power supplies. To remove a power supply, complete the following steps:
 - a. On the left side of a power supply, press the orange release tab to the right just enough to release the handle [no more than 6.4 mm (0.24 in.)] as you rotate the handle downward.

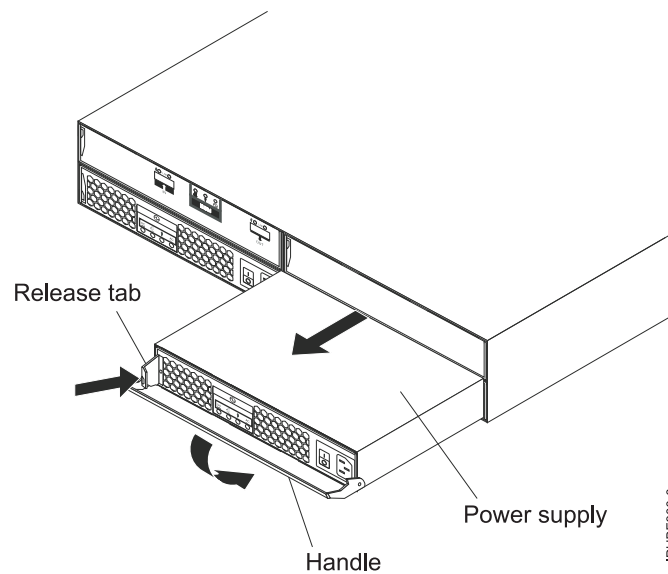

Figure 45. Removing power supplies

- b. Carefully slide the power supply out of the unit.
 - c. Repeat this step for the other power supply; then, set both units aside for later installation.
2. To reduce the weight of the unit for easier installation in the rack cabinet, remove the hard disk drives. To remove a hard disk drive, press the latch and pull out the handle; then, carefully pull the drive from the unit. Repeat this step for all hard disk drives.

Note:

- a. Before you remove any hard disk drives, make sure that you mark their locations so that you can reinstall them in the same locations.
- b. Handle hard disk drives gently and do not stack them. Follow all precautions for static-sensitive devices.

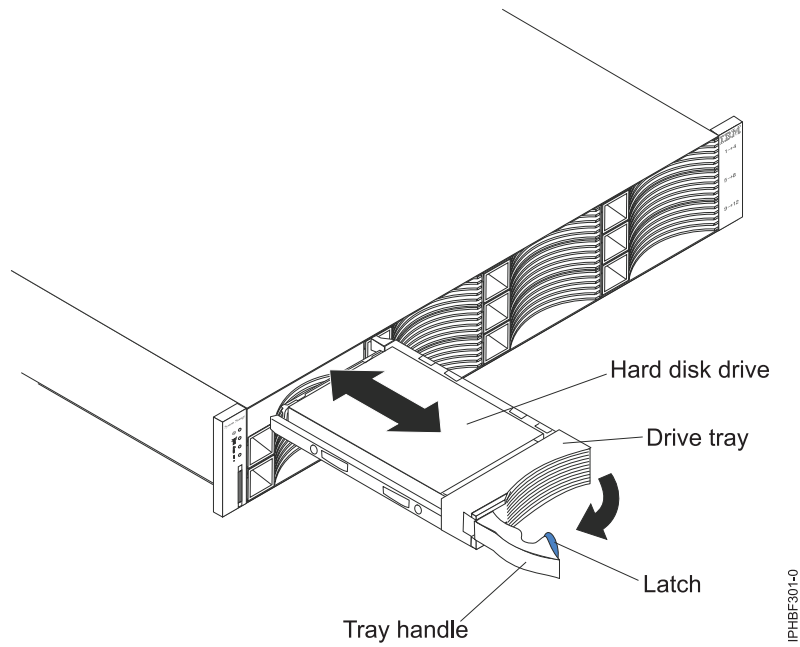
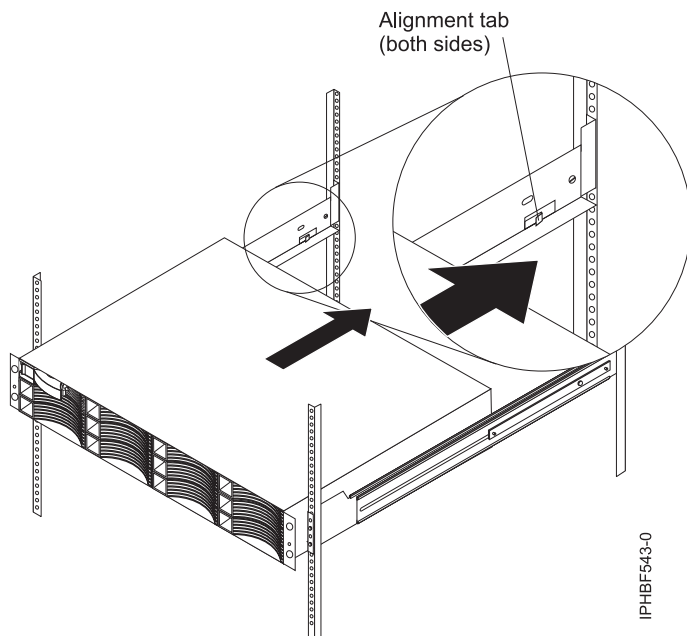

Figure 46. Removing disk drives

3. Lift the disk drive enclosure and position it over the front of the rails.

Attention: For the 5886, two people are required to lift the disk drive enclosure safely. Using fewer than two people to lift the disk drive enclosure can result in injury.

4. Slide the disk drive enclosure into the rack cabinet, making sure that it slides into the tabs on the rear of the rail.



5. Secure the front of the disk drive enclosure to the rack cabinet with one M5 screw in the open hole in each bracket (no washer is required).

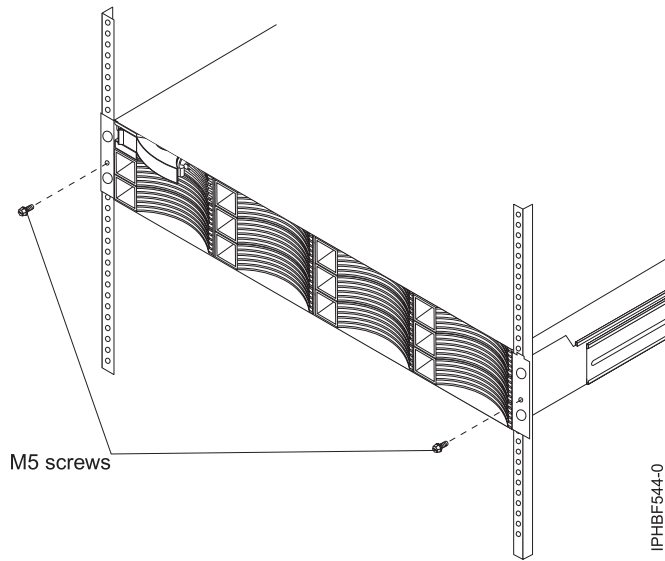
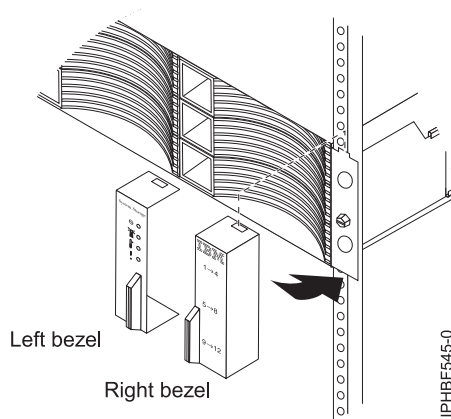

Figure 47. Installing the securing screws

6. Secure the rear of the disk drive enclosure to each rail assembly with one M4 pan-head screw in the slotted hole on the outside of the storage enclosure chassis wall.
7. Reverse the procedures in step 1 and step 2 to reinstall the power supplies and hard disk drives.
8. Connect a power cord to each power supply. Use the power-cord guide for strain relief to prevent the power cord from disconnecting accidentally.
9. Install the left bezel that has the LEDs, and then install the right bezel. Fit the cutout on the top of the bezel over the tab on the chassis flange. Rotate the bezel down until it snaps into place. Make sure that the inside surface of the bezel is flush with the chassis.



For instructions on how to connect and configure the expansion unit when you have completed installing the expansion unit into the rack, see Enclosures and expansion units.

Installing the 5796 or 7314-G30 expansion unit in a rack

This procedure can be used to install the 5796 or 7314-G30 expansion unit into a rack. The procedure includes information intended to promote safety and reliable operation, and provides illustrations on how hardware components relate to each other.

- This procedure assumes that you are installing the 5796 or 7314-G30 expansion unit into an existing rack. If the rack is not installed, you must perform the procedure for Chapter 3, “Installing the rack,” on page 5 before performing this procedure to install the expansion unit into the rack.

Note: This procedure applies only to the models that are designed to be mounted in a rack. Do not attempt to install a stand-alone model in a rack.

- Read the “Rack safety notices” on page 80.

To install the model 5796 or 7314-G30 into a rack, complete these steps:

CAUTION:

Installing the rails in the rack is a complex procedure. To install the rails correctly, you must perform each task in the following order. Failure to do so might cause rail failure and potential danger to yourself and the system unit.

1. Complete a parts inventory.
 - Locate the kitting report in an accessory box.
 - Ensure that you received all the parts that you ordered. There are two types of rail kits for this system.
 - Two expandable rails with extension brackets

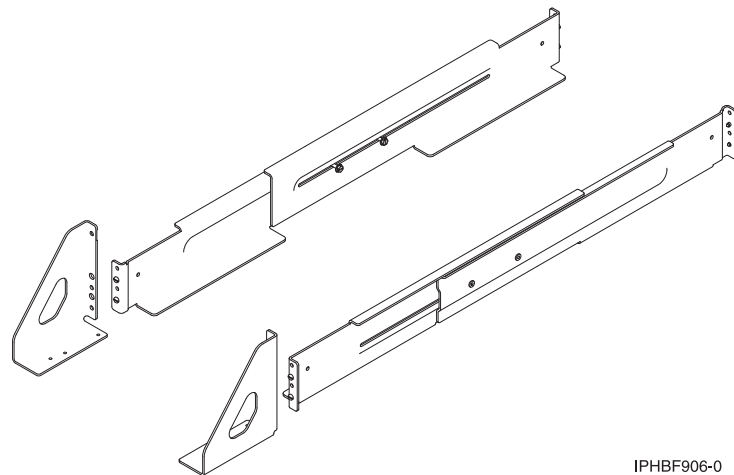

Figure 48. Expandable rails with extension brackets

Note:

- The 5796 and 7314-G30 do not use extension brackets.
- There are two versions of the rail kits for the 5796 and 7314-G30.

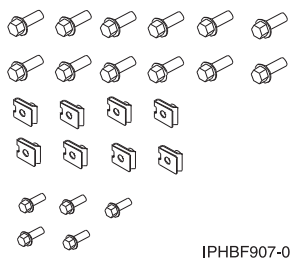

Figure 49. Rack-mounting kit

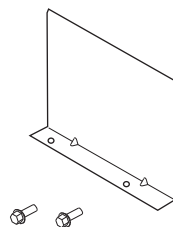

Figure 50. Filler plate and screws

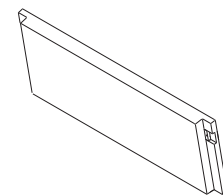



Figure 51. Front bezel

If there are incorrect, missing, or damaged parts, contact:

- Your IBM reseller
- IBM Rochester Manufacturing Automated Information Line at 1-800-300-8751 (United States only).

- Directory of worldwide contacts Web site at <http://www.ibm.com/planetwide>  (Locate your service and support telephone numbers.)
2. Ensure that there is an empty slot in an existing shell or that there is enough room in the rack to install a new shell.

Powering off the system and removing power

You might need to power off the system and remove power. Use the procedure in this section to perform this task.

1. Ensure that the system you are attaching to is running the latest level of firmware. For information on checking or upgrading the firmware level or your system, refer to the firmware updates section of your system's installation information.
2. After ensuring that your firmware is at the latest level, shut down and power off the system that you are attaching to. For information about shutting down and powering off the system, see the documentation provided with your expansion unit.
3. If you are installing an expansion unit into an existing shell, continue with "Installing the expansion unit" on page 63. Otherwise, refer to "Marking the location."

Marking the location

You might need to mark the location. Use the procedure in this section to perform this task.

To mark the installation location and install the nut clips into a rack, complete the following steps:

1. Determine where in the rack to place the expansion unit in relation to other system hardware. As you plan, keep the following in mind:
 - a. Organize larger and heavier units into the lower part of the rack.
 - b. Plan to install units into the lower part of the rack first.
 - c. Record the EIA locations in your plan.

Note: These expansion units are four Electronic Industries Alliance (EIA) units high. An EIA unit is 1.75 in. (44.50 mm) in height. The rack contains three mounting holes for each EIA unit of height. This system unit, therefore, is 7 in. (177.8 mm) high and covers 12 mounting holes in the rack.

The following illustration shows a 1-EIA unit and a 4-EIA unit. Depending on the rack manufacturer, the EIA units might be separated either by color or by a line. The holes along the EIA strip are not evenly spaced. If your rack has no color or line separation between EIAs, assume that each EIA section begins where the hole spacing is closest together.

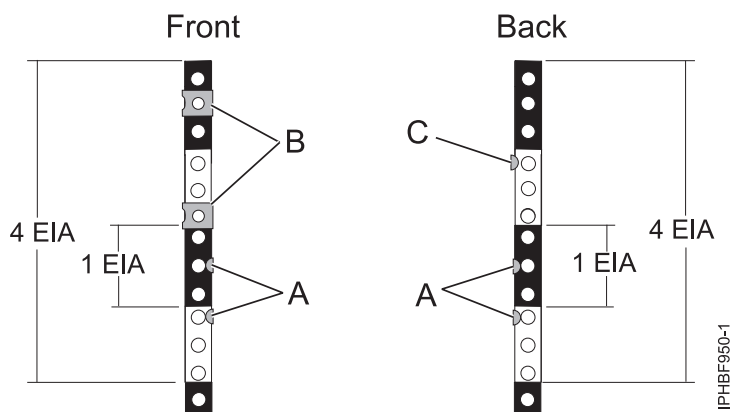

Figure 52. EIA units with expandable rails for the 5796 expansion unit

- A** Placement mark
- B** Nut clip

2. Facing the front of the rack and working from the right side, locate the bottom EIA unit that your expansion unit uses. Make a note of the EIA location. Use tape, a marker, or a pencil to mark the top hole of this EIA unit (**B**). Mark the rack so the mark can also be seen from the rear of the rack.
3. Begin with the hole identified by the mark placed in step 2; count up two holes and place a second mark. Mark the rack so the mark can also be seen from the rear of the rack.
4. Begin with the hole identified in substep 3, count up six holes and place a nut clip. The nut clip (**B**) aids in securing your expansion unit to the rack.
5. Begin with the hole identified in substep 3, count up two holes and place a nut clip. The nut clip (**B**) aids in securing your expansion unit to the rack.
6. Repeat steps 2 through 5 on the left side of the rack.
7. Facing the back of the rack and working from the right side, locate the bottom EIA unit that your expansion unit uses. Make a mark (**A**) next to the top hole of this EIA unit.
8. Begin with the hole identified by the mark placed in step 7 and count up two holes and place the second mark next to the hole.

Installing the standard (fixed length) rails

You might need to install standard (fixed length) rails into the rack. Use the procedure in this section to perform this task. In addition to related safety information, this section also includes illustrations of the related hardware components and shows how these components relate to each other.

Attention: To avoid rail failure and potential danger to yourself and to the expansion unit, ensure that you have the correct rails and fittings for your rack. If your rack has square support flange holes or screw-thread support flange holes, ensure that the rails and fittings match the support flange holes used on your rack. Do not install mismatched hardware using washers or spacers. If you do not have the correct rails and fittings for your rack, contact your IBM reseller. Also, to install the rails correctly, perform each task in the following order.

To install the standard (fixed length) rails, complete the steps in this section. If you have the expandable rail set, refer to “Installing the expandable rails and extension bracket into the rack” on page 60.

1. From the back of the rack, note the position of the two marks (**B**) previously marked on the front Electronic Industries Alliance (EIA) EIA strips. Install the rack-alignment pins for the left rail into the corresponding EIA holes located in the left front EIA strip (**A**).
2. From the back of the rack, align the rails with the two marks (**B**) previously marked on the front EIA strips. Loosely thread two retaining screws (**C**) into each rail, at the corresponding EIA strip holes.

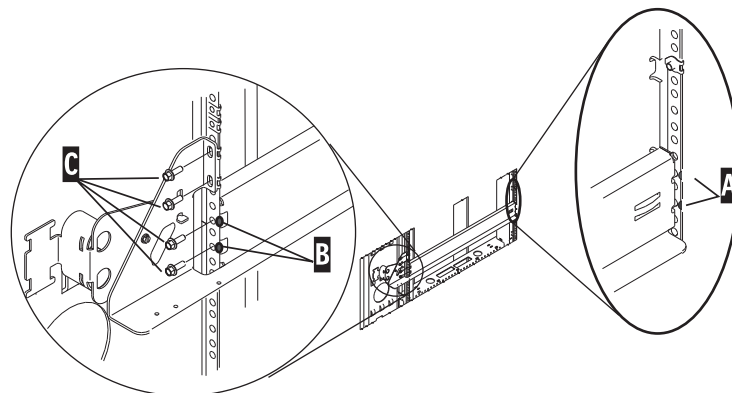

- A** Two front placement marks per rail
- B** Two back placement marks per rail
- C** Four retaining screws per rail

Figure 53. Installing the rails

3. Loosely thread two retaining screws into the back EIA strips where the nut clips were previously installed.
4. Repeat steps 1 through 3 for the right rail.
5. Tighten all screws.

Installing the expandable rails and extension bracket into the rack

You might need to install rails into the rack. Use the procedure in this section to perform this task. In addition to related safety information, this section also includes illustrations of the related hardware components and shows how these components relate to each other.

Attention: Installing the rails in the rack is a complex procedure. To install the rails correctly, you must perform each task in the following order. Failure to do so might cause rail failure and potential danger to yourself and the system unit.

To install the expandable rails into the rack, complete the following steps:

1. Loosen the two screws (**B**) in the middle of both rails (**A**) to allow each rail to extend.

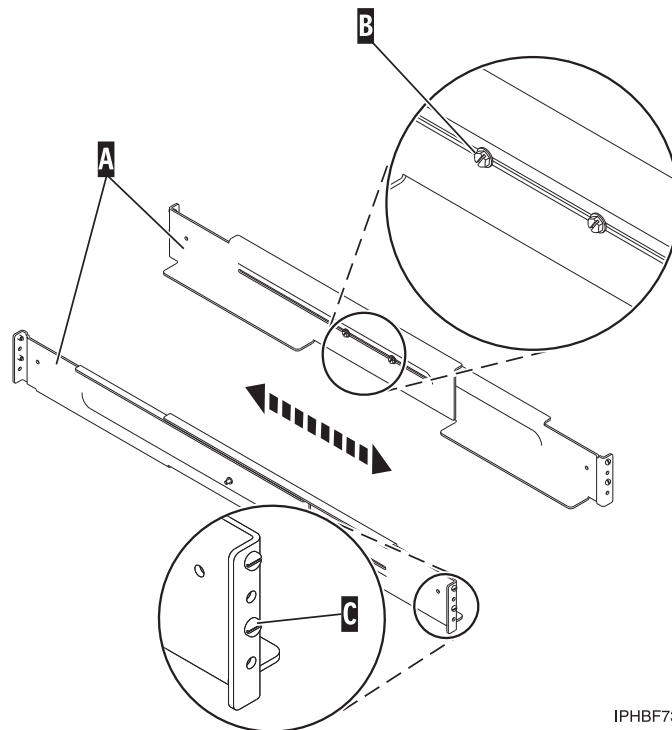

IPHBF731-0

Figure 54. Extending the rails

2. Starting at the back of the rack, extend the left rail. Insert the rail pins (**C**) into the marked locations on the rack so that it is facing upward (L shape).
3. From the back of the rack, extend the right rail and insert the rail pins (**C**) into the marked locations.

4. Move to the front of the rack, extend the left rail and insert the rail pins (C) into the marked locations.
5. Extend the right rail and insert the rail pins (C) into the marked locations.
6. Using one M5 screw (D), secure the left rail to the front of rack into the lower location (E).
7. Using one M5 screw (D), secure the right rail to the front of the rack into the lower location (E).
8. Insert two nut clips at the marked location on the front-left rail of the rack.
9. Insert two nut clips at the marked locations on the front-right rail of the rack.
10. Move to the back of the rack and insert two nut clips at the marked locations on the back-left rail of the rack.
11. Insert two nut clips at the marked location on the back-right rail of the rack.
12. Use three M5 screws (G) to secure each rail arm and bracket (F) to the rack.

Note: Each bracket will face inward.

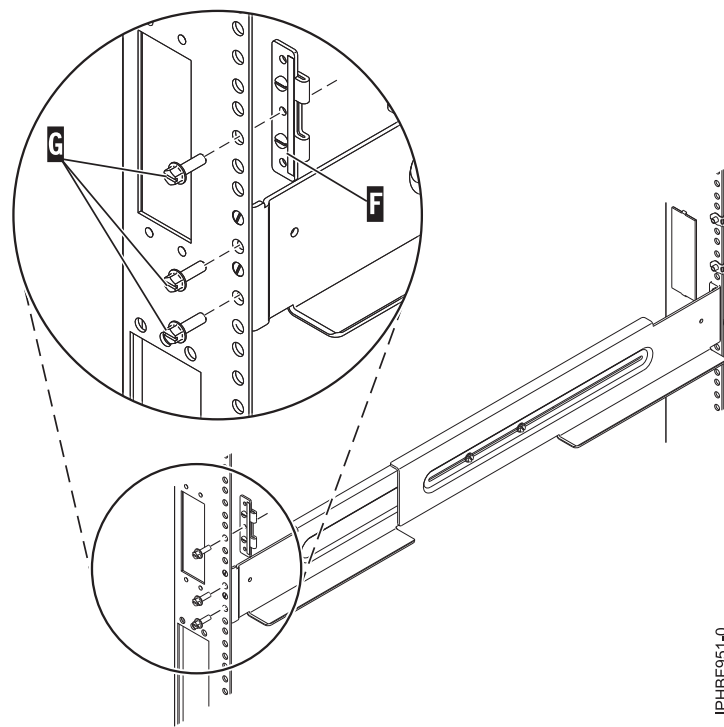

Figure 55. Attaching the rails to the back of the rack

13. Tighten the two screws (B) in the middle of the left rail and the two screws (B) in the middle of the right rail. Refer to Figure 54 on page 60.

Installing the shell

You might need to install the shell. Use the procedure in this section to perform this task. This section also includes illustrations of the related hardware components and shows how these components relate to each other.

Note: Before installing the shell, ensure that the rails are level from side to side and from front to back.

To install the shell, complete the following steps:

1. From the front of the rack, place the shell (A) on the rails and slide it into the rack.

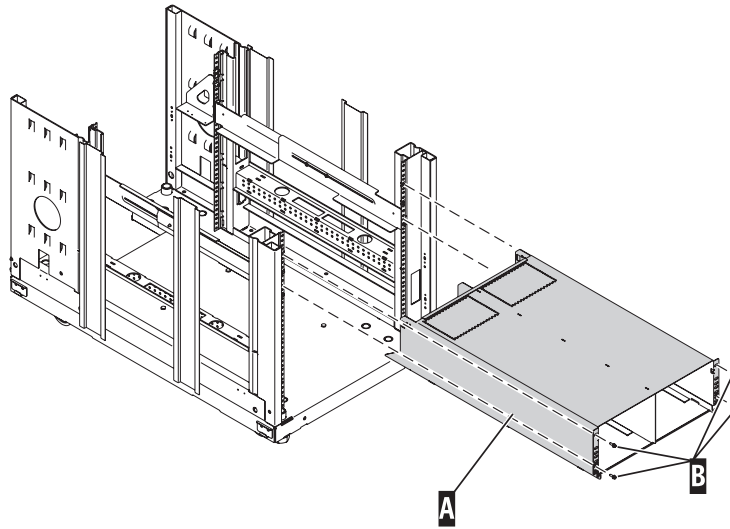

IPHBF903-2

Figure 56. Installing the shell into the rack on the expandable rails

- A** Shell
- B** Retaining screws (four)

2. Install and tighten the four retaining screws (**B**) into the front of the shell, securing the shell (**A**) to the rack.
3. If you are only installing one expansion unit, move to the back of the rack and secure the shell (**A**) with the retaining screw (**C**). Ensure that screw **C** is attached to the slot of the shell opposite of the slot in which you intend to place the expansion unit.

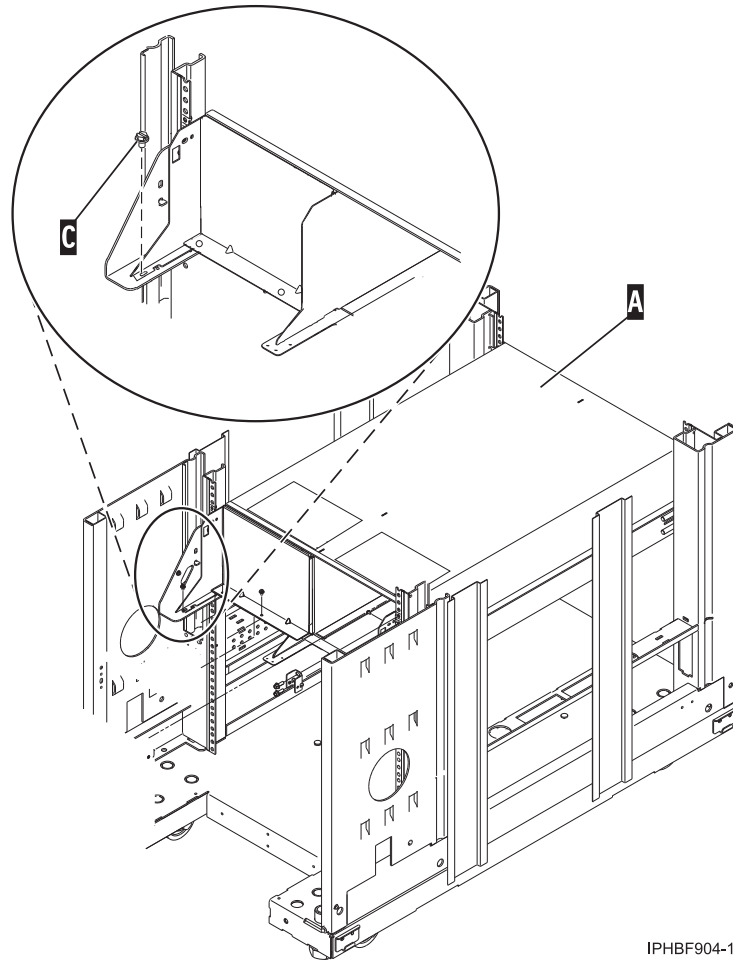

Figure 57. Securing the shell to the rack with the expandable rails

- A** Shell
- C** Retaining screws (four)

Installing the expansion unit

You might need to install the expansion unit into the rack. Use the procedure in this section to perform this task. This section also includes illustrations of the related hardware components and shows how these components relate to each other.

To install the expansion unit into a rack, complete the following steps:

1. If you are installing a 5796 or 7314-G30 expansion unit into the rack, slide the unit in from the front of the shell.

Important: When installing the 5796 or 7314-G30, first remove the front and back shipping covers. These shipping covers are secured by four thumb screws each. Two screws are located on the top of the cover and two are located on the sides of the cover.

2. If you are installing a expansion unit (**H**) into an existing shell (**G**), remove the filler plate (**F**) by pressing down the tops tabs and pulling it out.

Note: Your shell may have one or two filler plates. If there is a filler plate where you want to install your drawer, you need to remove the filler plate.

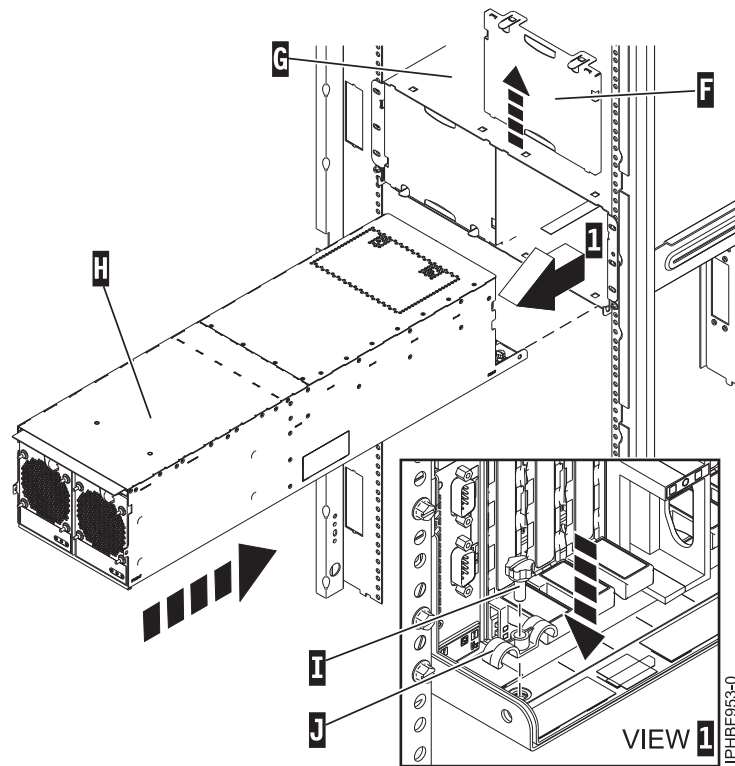

- F** Filler plate
- G** Shell
- H** Drawer
- I** Thumb screw
- J** Cable retention bracket

Figure 58. Removing the filler plate

3. Carefully move any existing cables that are blocking the expansion unit location.
4. Slide the expansion unit (**H**) into the shell.
5. If you are installing a 5796, use a thumb screw (**I**) to install the cable retention bracket (**J**).
6. If you are installing two expansion units, repeat steps 1 through 5. If there is only one expansion unit installed in the shell, ensure that the filler plate (**N**) is installed in the blank slot.
7. To install the filler plate (**N**) in the blank slot in the shell beside a 5796, slide the filler plate up under the top tab of the shell. Gently press the filler plate into place.

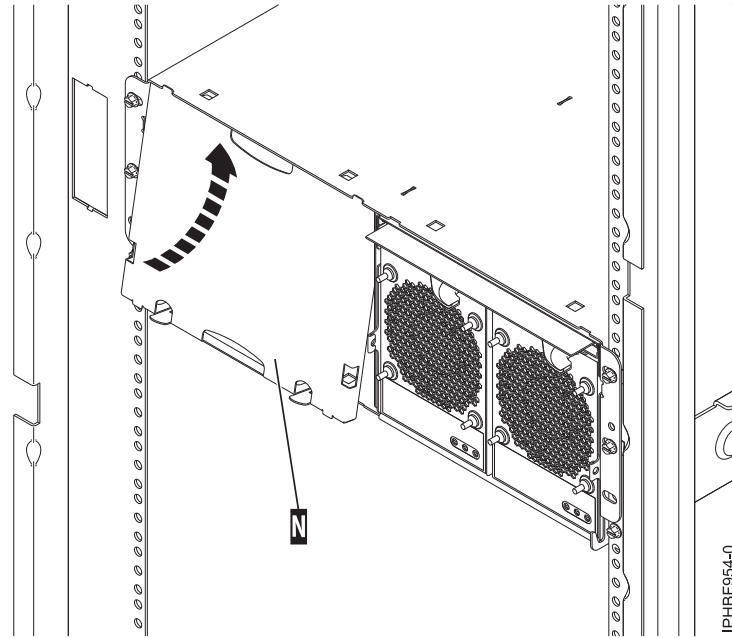

N Filler plate

8. Attach the front cover. See “Installing the front cover on the 7314-G30 or 5796” on page 119.

Attaching the power controller (SPCN), and power cables

You might need to attach the System Power Control Network (SPCN) and power cables to the expansion unit. Use the procedure in this section to perform this task.

For instructions on cabling and connecting your expansion units, see Enclosures and expansion units.

Powering on the system

You might need to power on the expansion unit. For information about powering on the expansion unit, refer to Start the system or logical partition.

Installing the model 5786 or 7031-D24 into a rack

You might need to install the expansion unit into a rack. This section includes procedures so that you can perform these tasks.

This procedure assumes that you are installing the expansion unit into an existing rack. If the rack is not installed, follow the instructions in Chapter 3, “Installing the rack,” on page 5. Return to this procedure for instructions on installing the expansion unit into the rack.

When you have installed the expansion unit into the rack, you will need the instructions in Disk drives, to connect and configure the 7031-D24 or 5786.

Note: This procedure applies only to the models that are designed to be mounted into a rack.

To install the expansion unit into a rack, perform the following steps:

Attention: Installing the rails in the rack is a complex procedure. To install the rails correctly, you must perform each task in order. Failure to do so might cause rail failure and potential danger to yourself and the expansion unit.

1. Read the "Rack safety notices" on page 80. Failure to read these notices could cause damage to the equipment or injury to the installer.
2. Complete a parts inventory (See "Completing a parts inventory").
3. Locate the rack-mounting hardware kit (A) and the system rail assemblies (B) that were included with your expansion unit. See Figure 59 for the relative locations of these items. The system rails are identical.

Note: An 8 mm nut driver and a flat-blade screwdriver, represented in the following diagram, are not listed in the inventory or included in the parts shipped. These tools assist you in completing the installation.

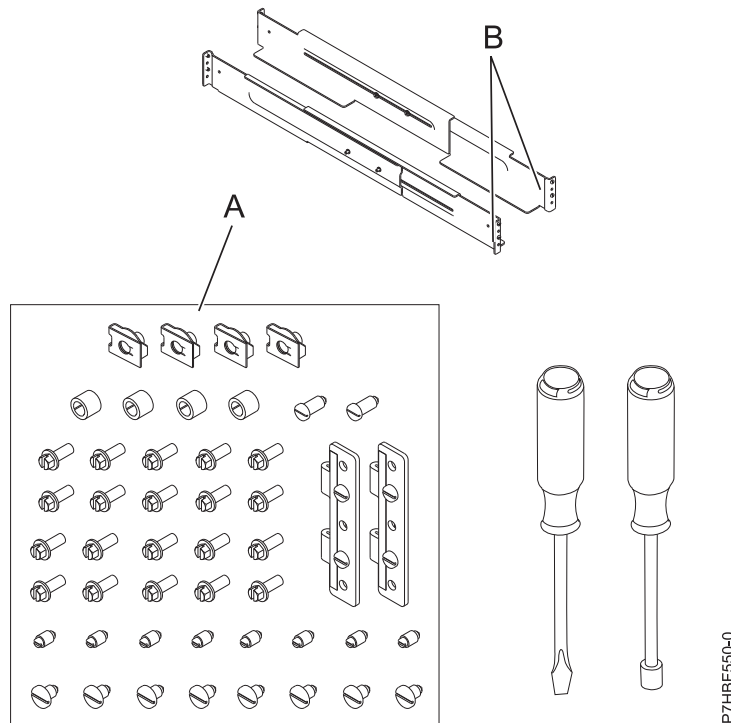

Figure 59. Parts inventory

4. Determine where you will locate the expansion unit in the rack. See "Determining the location" on page 67. This expansion unit is 4 Electronic Industries Alliance (EIA) units high. An EIA unit is 1.75 in (44.45 mm) in height. The rack contains three mounting holes for each EIA unit of height.
5. To mark the location, see "Marking the location" on page 68.

Completing a parts inventory

You might need to complete a parts inventory. Use the procedure in this section to perform this task.

If you have not done so, complete a parts inventory before proceeding with the installation:

1. Locate the kitting report in an accessory box.
2. Ensure that you received all the parts that were ordered.

If there are incorrect, missing or damaged parts, contact:

- Your IBM reseller
- IBM Rochester Manufacturing Automated Information Line at 1-800-300-8751 (United States only)

- Directory of worldwide contacts Web site at <http://www.ibm.com/planetwide>  (Locate your service and support telephone numbers.)

Determining the location

You might need to determine where to install an expansion unit in the rack. Use this procedure to perform this task.

Before installing the expansion unit into a rack, complete the following steps:

1. Read the “Rack safety notices” on page 80.
2. Plan where you will place the units. Place the larger and heavier units in the lower part of the rack. These expansion units are four Electronic Industries Alliance (EIA) units high. The rack contains three mounting holes for each EIA unit of height. Each of these units therefore is 7 in. (177.8 mm) high and covers 12 mounting holes in the rack.
3. Remove the filler panels to allow access to the inside of the rack enclosure where you plan to place the unit.

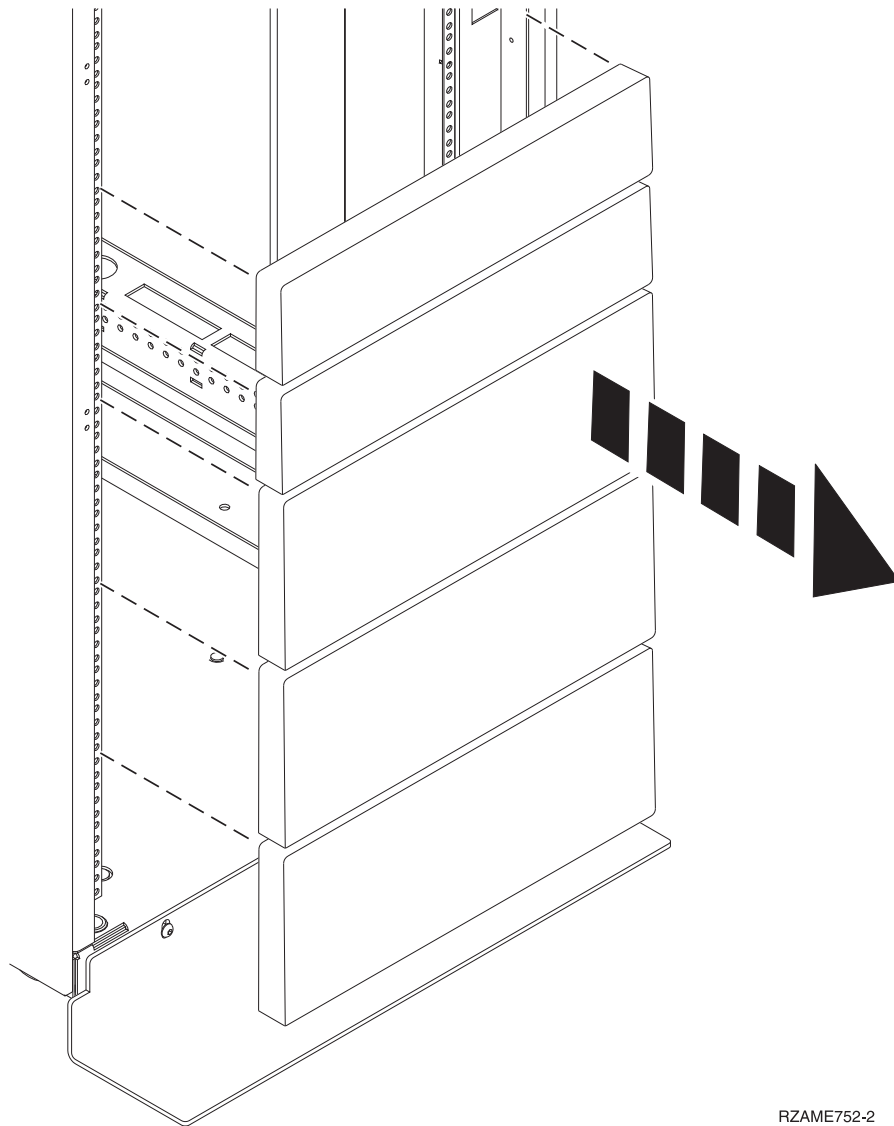

RZAME752-2

Figure 60. Removing the filler panels

4. Remove the front and back rack doors if necessary.
5. To mark the location, see “Marking the location.”

Marking the location

You might need to mark the location for the rack installation. Use the procedure in this section to perform this task.

To mark the installation location and install the nut clips into a rack, complete these steps:

1. Determine where in the rack to place the unit and make note of the location numbers. This unit is four Electronic Industries Alliance (EIA) units high. An EIA unit is 1.75 in. (44.45 mm) in height. The rack contains three mounting holes for each EIA unit of height. This unit therefore is 7 in. (177.8 mm) high and covers 12 mounting holes in the rack.
2. Facing the front of the rack and working from the left side, locate the lowest EIA unit that your unit uses. Make a note of the EIA location. Use tape, a marker, or a pencil to mark the top mounting hole **(B)** of this EIA unit. Mark the rack so that the mark can be seen from the rear of the rack.

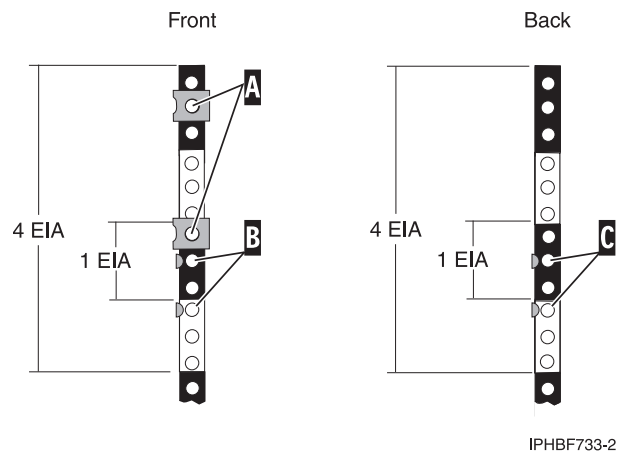

Figure 61. Marking the installation locations

3. On the left rail, count up two mounting holes from where you placed the mark in step 2 and place another mark next to that mounting hole **(B)**. Mark the rack so that the mark can be seen from the rear of the rack. You now have two marks on the rack, with one mounting hole between the marks.
4. Repeat steps 2 and 3 to place two marks on the corresponding mounting holes on the front-right rail.
5. Go to the back of the rack. On the left side, find the EIA unit that corresponds to the lowest EIA unit marked on the front of the rack.
6. Place a mark at the top hole **(C)** of the lowest EIA unit. Mark the rack so that the mark can be seen from the rear of the rack.
7. Count up two mounting holes from where you placed the mark in step 6 and place another mark next to that mounting hole **(C)**.
8. Repeat steps 6 and 7 to place two marks on the corresponding mounting holes on the rear-right rail.

Attaching the mounting hardware to the rack

You might need to attach mounting hardware to the rack. Use the procedure in this section to perform this task. In addition to information intended to promote safety and reliable operation, this section also includes illustrations of the related hardware components and shows how these components relate to each other.

CAUTION:

Installing the rails in the rack is a complex procedure. To install the rails correctly, you must perform each task in the following order. Failure to do so might cause rail failure and potential danger to yourself and the system unit.

To install the mounting hardware into the rack, follow these steps:

1. Loosen the two screws (B) in the middle of both rails (A) to allow each rail to extend.

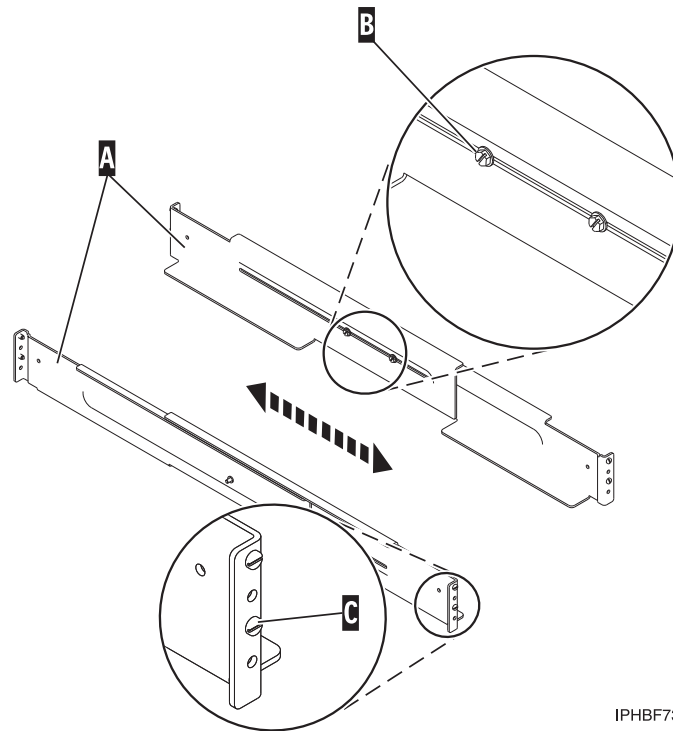

IPHBF731-0

Figure 62. Extending the rails

2. Starting at the back of the rack, extend the left rail and insert the rail pins (C) into the marked locations the rack so that the rail is facing upward.

Note: Although the rail installation can be completed by one person, the installation will be easier if one person is positioned at the front of the rack and one person is positioned at the back of the rack.

3. From the back of the rack, extend the right rail and insert the rail pins (C) into the marked locations.
4. Moving to the front of the rack, extend the left rail and insert the rail pins (C) into the marked locations.
5. Extend the right rail and insert the rail pins (C) into the marked locations.
6. Using two M5 screws (D), secure the left rail to the front of rack below each rail pin (C).

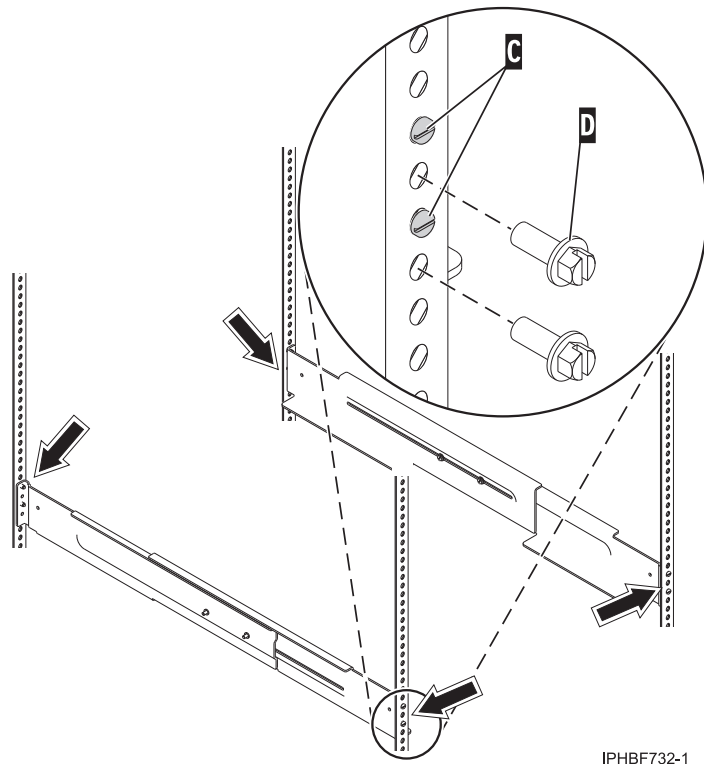

Figure 63. Attaching the system rails

7. Using two M5 screws (D), secure the right rail to the front of the rack.
8. Moving to the back of the rack and using two M5 screws (D), secure the left rail to the back of the rack.
9. Using two M5 screws (D), secure the right rail to the back of the rack.
10. Tighten the two screws in the middle of the left rail and the two screws in the middle of the right rail. Refer to Figure 63.
11. Insert two nut clips at the marked location on the front-left rail.
12. Insert two nut clips at the marked locations on the front-right rail.

Installing the 5786 or 7031-D24 on the rail assembly

You might need to install the expansion unit on the rail assembly. Use the procedure in this section to perform this task. In addition to related safety information, this section also includes illustrations of the related hardware components and shows how these components relate to each other.

Before installing the expansion unit on the rail assembly, ensure that the stabilizers are extended and the tip plate is attached to the bottom front of the rack to prevent the rack from falling forward when the rails are pulled out of the rack. Refer to “Rack safety notices” on page 80.

To install the expansion unit on the rail assembly, follow these steps:

1. If the bezel is installed on the front of the expansion unit, remove it by pressing in on the two release buttons.

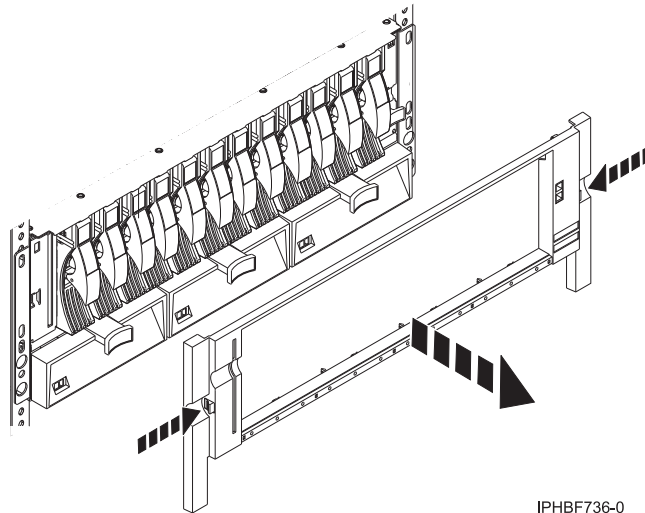

Figure 64. Removing the bezel

2. Using three people, lift the expansion unit and position it over the front of the rails.

Attention: Three people are required to safely lift the expansion unit. Using fewer than three people to lift the expansion unit can result in injury.
3. Push the expansion unit into the rack until it is completely installed into the rack.
4. Determine whether the securing plates are preinstalled on the back of the expansion unit. If not, attach the plates to the back left and back right of the expansion unit. The securing plates are illustrated in Figure 66 on page 72.
5. Install the two M5 securing screws **A** through the chassis and into the nut clips **(B)** on the left and right rail.

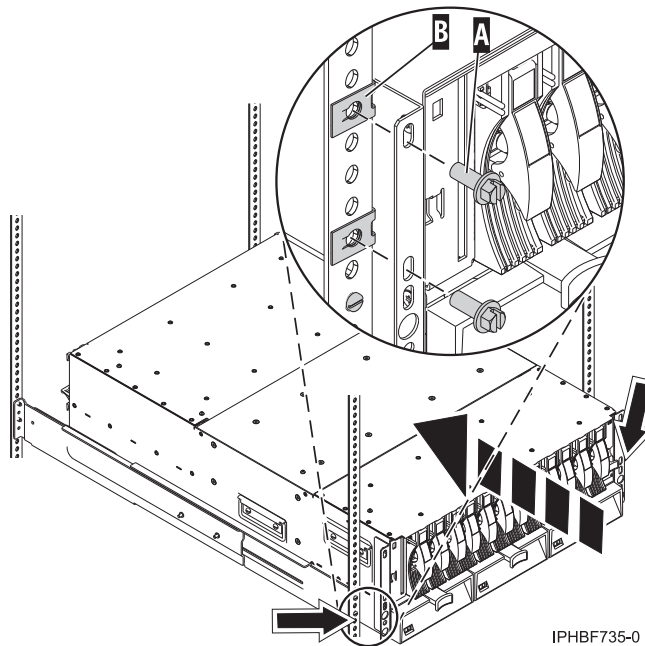
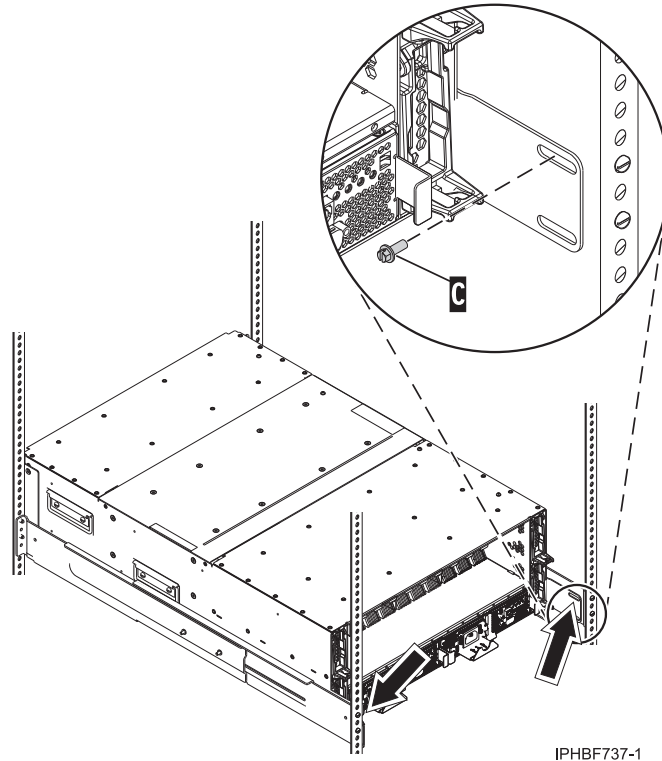

Figure 65. Installing the securing screws

- At the back of the rack, install two M5 securing screws (C) through the back of both the left and right securing plates and into the rack rail.



IPHBF737-1

Figure 66. Securing the expansion unit to the back of the rack

- Install the bezel onto the expansion unit.

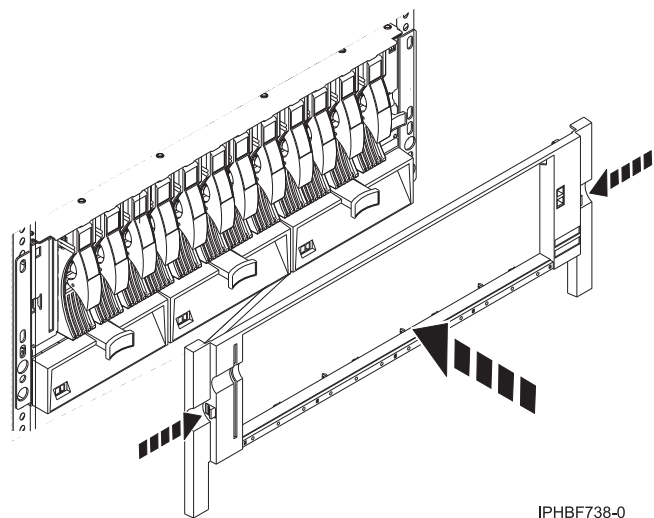

IPHBF738-0

Figure 67. Installing the bezel

For instructions on how to connect and configure the expansion unit when you have completed installing the 5786 or 7031-D24 into the rack, see Enclosures and expansion units.

Attaching the cable-management arm to the standard rails

You might need to attach the cable-management arm. Use the procedure in this section to perform this task.

If standard (fixed length) rails were included with the expansion unit, and the cable-management arm is not attached to the rails, complete the following steps. Otherwise, go to “Determining the location” on page 67.

1. Insert the cable-management arm rail tab (**B**) into the rail.
2. Rotate the cable-management arm (**A**) as shown in the following illustration.

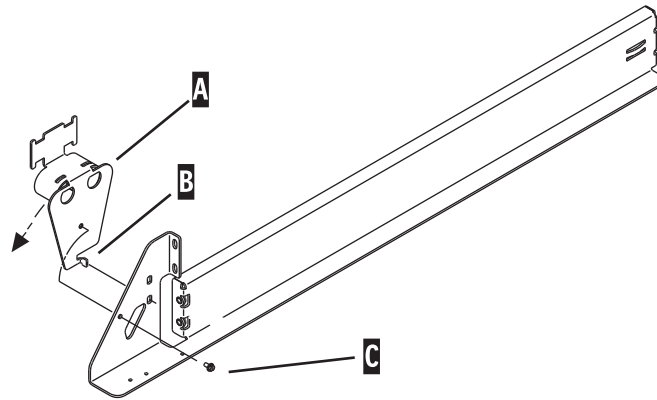

Figure 68. Rotating the cable-management arm

3. Secure the cable-management arm (**A**) with the retaining screw (**C**).
4. Repeat steps 1 through 3 for the other rail.

Chapter 5. Removing and replacing 7014-T00 or 7014-T42 side panels

You might need to remove and replace a side panel on a rack. Use the procedure in this section to perform this task.

The rack might have optional side panels. To remove and replace a side panel, complete the following procedure:

1. Unlock the side panels by pressing down on both locking latches to release the latches.

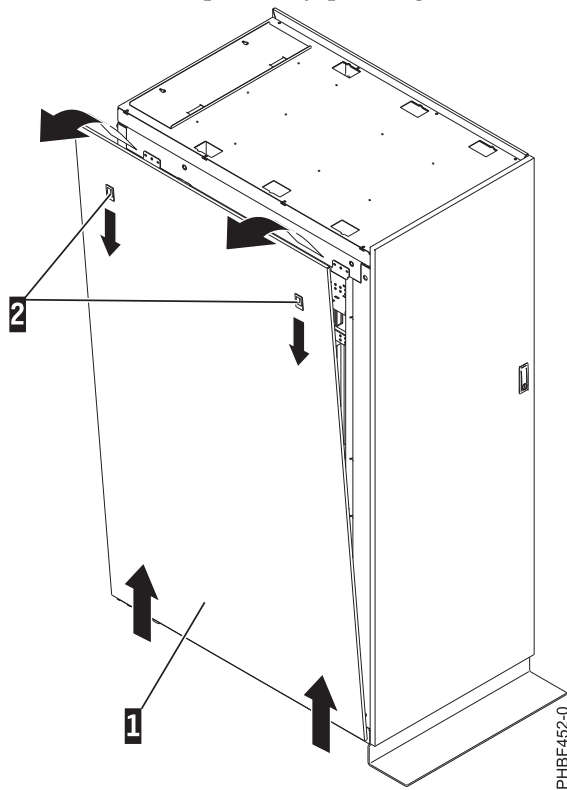

Figure 69. Removing the side panel

Note: If your rack uses a ruggedized kit, you must remove the securing screw to allow each side panel to be removed. Refer to “Releasing the side panel with a ruggedized kit” on page 88.

2. Tilt the top of the side panel slightly toward you.
3. Lift the side panel away from the ridge on the bottom of the rack.
4. Repeat this procedure for the other side panel.

Replacing a 7014-T00 or 7014-T42 side panel

You might need to replace a side panel on a rack. Use the procedure in this section to perform this task.

To replace a side panel, complete the following procedure:

1. Tilt the top of the side panel slightly toward you.

2. Place the bottom of the side panel onto the ridge on the bottom of the rack.

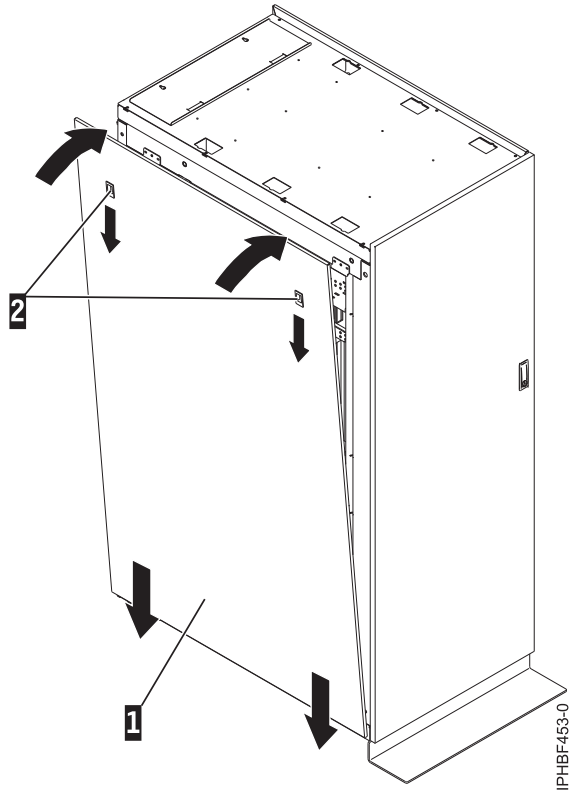

Figure 70. Replacing the side panel

3. Slide the top of the side panel into place and close the locking latches.

Note: If your rack uses ruggedized kit, you must install a securing screw into each side panel that was installed. Refer to Chapter 9, "Ruggedized kit," on page 87.

Chapter 6. Removing and replacing 7014-T00 or 7014-T42 trim panels

Racks that are installed with multiple processor drawer systems can use front trim panels in lieu of doors. For racks that use trim panels, a reduced-interference panel type must be installed when certain expansion unit models are present. Use the procedure in this section to remove the existing trim panels from the rack and replace it with the reduced-interference panel type.

To remove the existing rack trim panels, complete the following procedure:

1. Place both hands on the center of the right side trim panel.

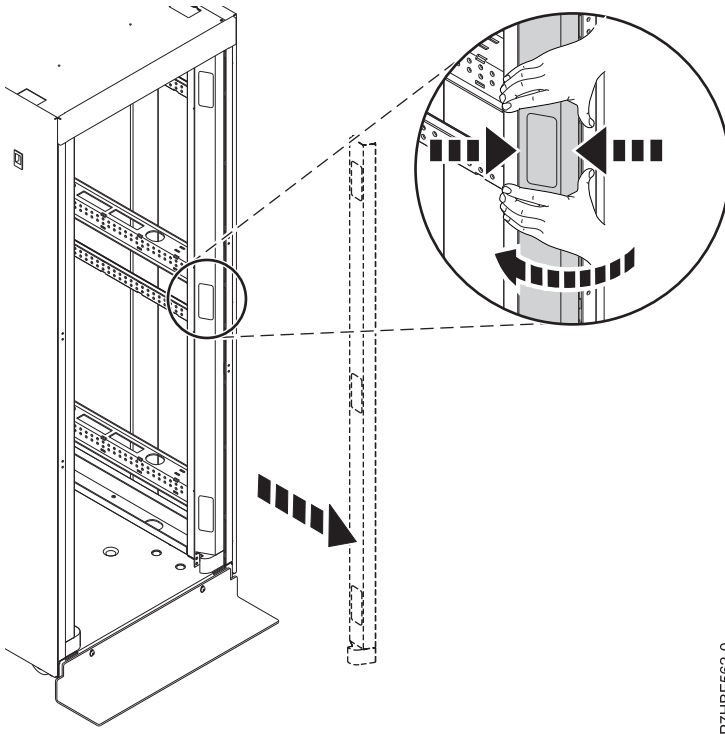

P7HBF562-0

Figure 71. Removing the rack trim panel

2. Squeeze inward firmly with your fingertips, to release the spring clips that hold the panel in place.
3. Rotate your hands in slightly until the panel is disengaged.
4. Lift the panel out and set it aside.
5. Repeat this procedure to remove the left side trim panel.

Replacing the 7014-T00 or 7014-T42 trim panels

For racks that use trim panels in lieu of doors, a reduced-interference panel type must be installed when certain expansion unit models are present. Use the procedure in this section to perform this task.

To install the trim panels, complete the following procedure:

1. Align the bottom plate (A) of the right side trim panel to the bottom of the rack

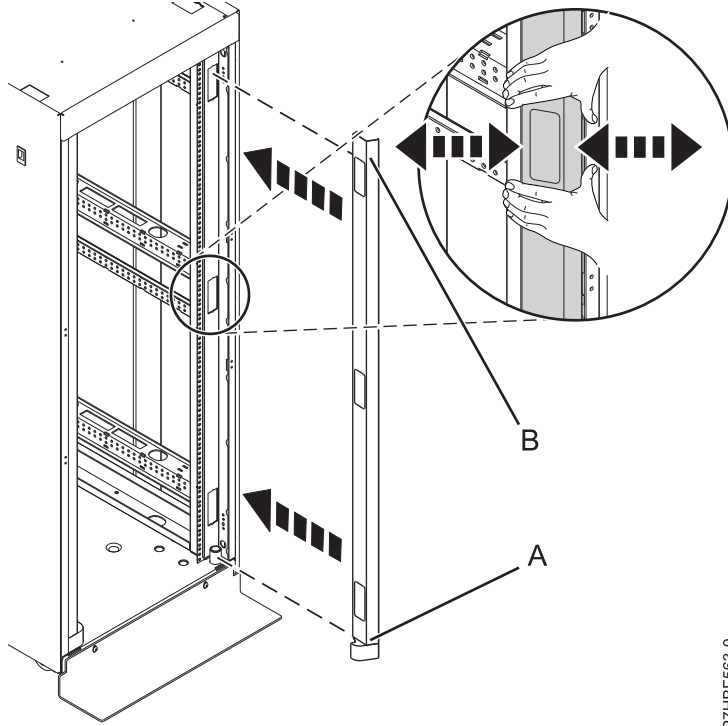

P7HBF563-0

Figure 72. Installing the rack trim panel

2. Align the top of the trim panel (B) and squeeze slightly with your fingertips.
3. Once the trim panel is in the proper location, release the pressure to allow the spring clips to hold the panel in place.
4. Repeat this procedure to install the left side trim panel.

Chapter 7. Attaching the rack doors

You might need to attach the rack doors. Use this procedure to perform this task.

Depending on the model of the rack, the front door of a rack might be an optional feature. If your system already has the front door installed, or does not have a front door to install, skip this step.

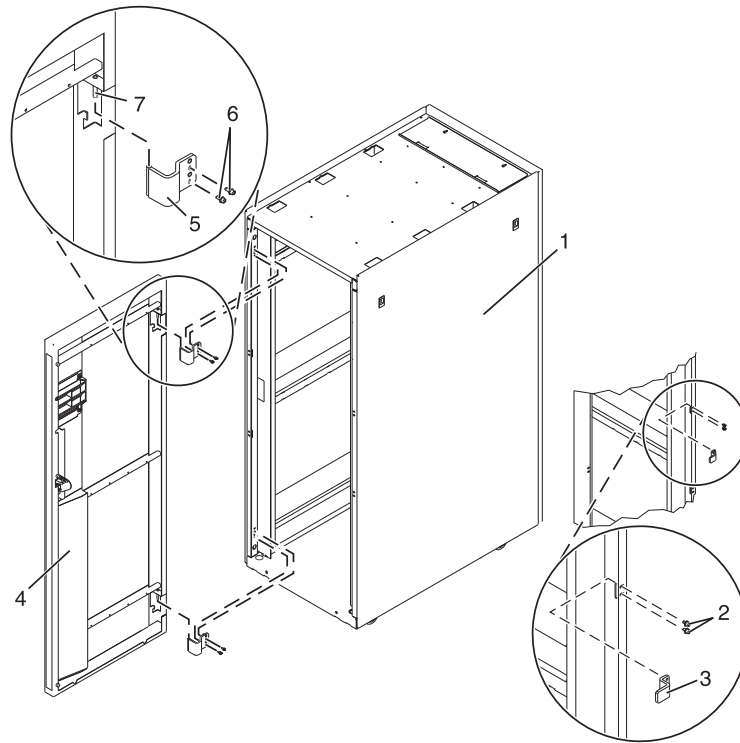

Figure 73. Attaching the rack door

Attaching a high-perforation front door

You might need to attach a front door to the rack. Use the procedure in this section to perform this task.

To install the high-perforation front door, do the following:

1. Read the "Rack safety notices" on page 80.
2. Remove the top, left, and right trim panels. For details on removing the left and right trim panels from a7014-T00 or 7014-T42 rack, see Chapter 6, "Removing and replacing 7014-T00 or 7014-T42 trim

panels,” on page 77.

Figure 74. Removing the trim panels

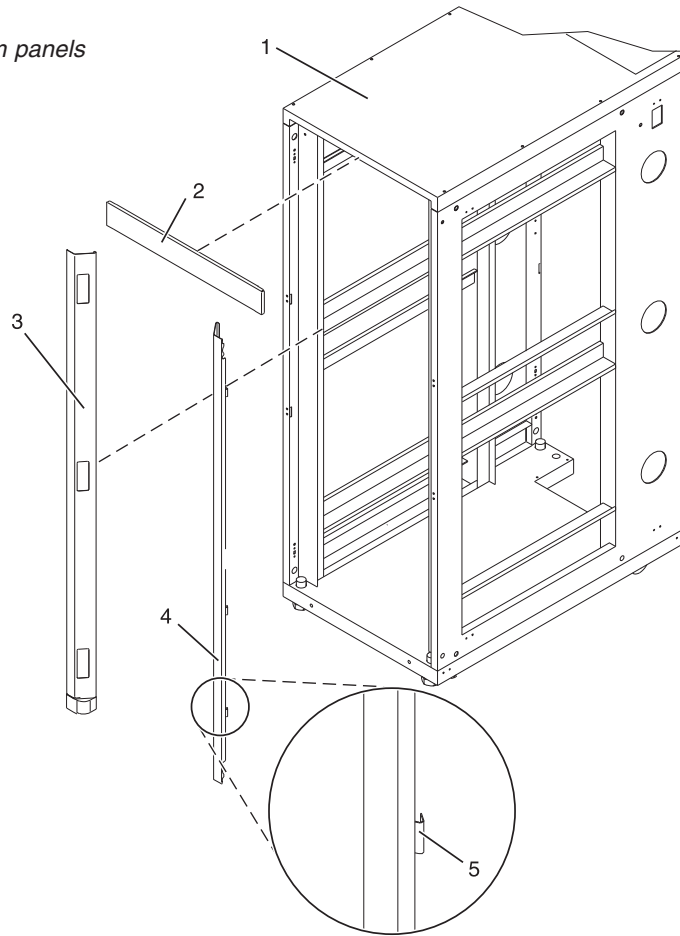

- 1 Rack chassis
- 2 Top trim panel
- 3 Left-side trim panel

- 4 Right-side trim panel
- 5 Spring clip

3. Install the door latch on the right and the door hinges on the left.
4. For a high-perforation front door, align the door over the rack hinge, then move up the hinge pin on the door, and lower the hinge pin into the hinge.
5. Adjust the latch so the door latches securely.

Rack safety notices

You need to read the rack safety notices before installing equipment.

Before installing a rack, rack features, or a system or expansion unit into a rack, read the following safety information.

Attention: If you are installing equipment into a non-IBM rack, the rack must comply with the Electronics Industries Association (EIA) 310D specifications. If you do not have a rail kit designed for the equipment in the non-IBM rack, do not install the equipment into the rack as damage to the equipment or personal injury could occur.

DANGER

Observe the following precautions when working on or around your IT rack system:

- Heavy equipment—personal injury or equipment damage might result if mishandled.
- Always lower the leveling pads on the rack cabinet.
- Always install stabilizer brackets on the rack cabinet.
- To avoid hazardous conditions due to uneven mechanical loading, always install the heaviest devices in the bottom of the rack cabinet. Always install servers and optional devices starting from the bottom of the rack cabinet.
- Rack-mounted devices are not to be used as shelves or work spaces. Do not place objects on top of rack-mounted devices.



- Each rack cabinet might have more than one power cord. Be sure to disconnect all power cords in the rack cabinet when directed to disconnect power during servicing.
- Connect all devices installed in a rack cabinet to power devices installed in the same rack cabinet. Do not plug a power cord from a device installed in one rack cabinet into a power device installed in a different rack cabinet.
- An electrical outlet that is not correctly wired could place hazardous voltage on the metal parts of the system or the devices that attach to the system. It is the responsibility of the customer to ensure that the outlet is correctly wired and grounded to prevent an electrical shock.

CAUTION

- Do not install a unit in a rack where the internal rack ambient temperatures will exceed the manufacturer's recommended ambient temperature for all your rack-mounted devices.
- Do not install a unit in a rack where the air flow is compromised. Ensure that air flow is not blocked or reduced on any side, front, or back of a unit used for air flow through the unit.
- Consideration should be given to the connection of the equipment to the supply circuit so that overloading of the circuits does not compromise the supply wiring or overcurrent protection. To provide the correct power connection to a rack, refer to the rating labels located on the equipment in the rack to determine the total power requirement of the supply circuit.
- *(For sliding drawers.)* Do not pull out or install any drawer or feature if the rack stabilizer brackets are not attached to the rack. Do not pull out more than one drawer at a time. The rack might become unstable if you pull out more than one drawer at a time.
- *(For fixed drawers.)* This drawer is a fixed drawer and must not be moved for servicing unless specified by the manufacturer. Attempting to move the drawer partially or completely out of the rack might cause the rack to become unstable or cause the drawer to fall out of the rack.

(R001)

Lift precautions:



18-32 kg (39.7-70.5 lbs)



32-55 kg (70.5-121.2 lbs)



≥ 55 kg (≥121.2 lbs)

IP-HBF443-0

Chapter 8. Installing the rack security kit

You might need to install the rack security kit. Use the procedure in this section to perform this task. This section also includes illustrations of the related hardware components and shows how these components relate to each other.

To install a rack security kit (feature 6580) that consists of the security lock and security slide bars, complete the following procedure:

1. Read the "Rack safety notices" on page 80.
2. Verify the inventory in the rack security kit.

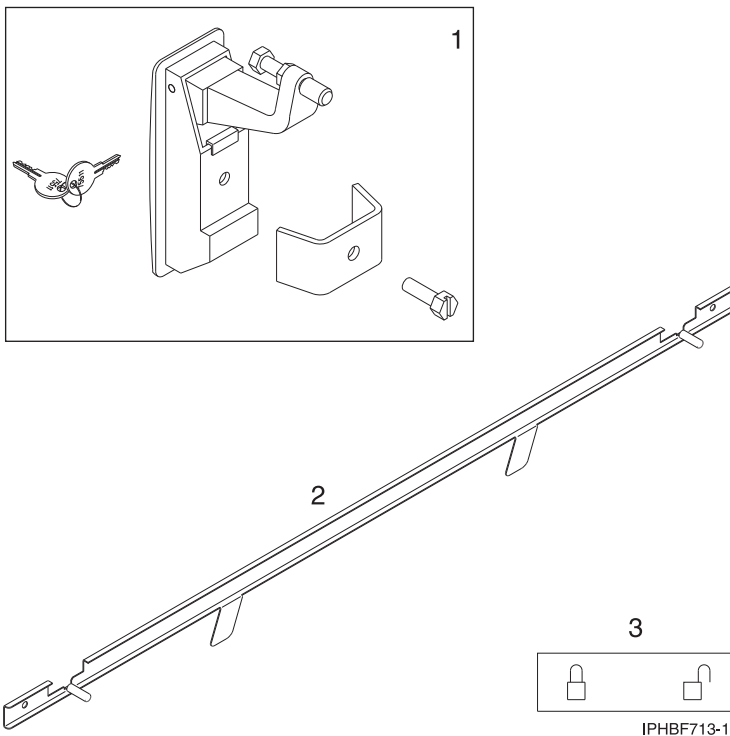

-
- 1** Two lock hardware kits. Each kit contains:
 - Rack lock
 - Bracket
 - Screw
 - Two keys
 - 2** Two security slide bars
 - 3** Two locked/unlocked stickers

Figure 75. Rack security kit inventory

3. Remove the existing door latch.

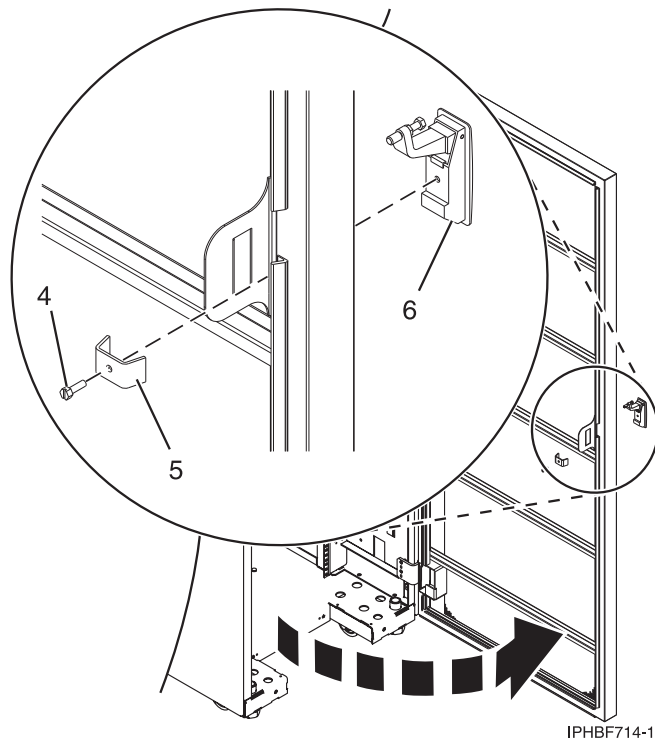

Figure 76. Removing the existing door latch

- a. Open the front rack door.
- b. On the inside of the door, remove the screw (4) in Figure 76, that secures the lock to the rack door.
- c. Remove the bracket (5).
- d. From the outside of the door, remove the door latch (6).

Note: If the rack is equipped with the ruggedized kit, remove the jam nut and hex nut from the existing door latch and reinstall both nuts on the new door lock latch.

4. Install the locking latch.
 - a. Insert the keyed rack lock into the latch slot on the front of the door (6) in Figure 76.
 - b. Secure the lock by attaching the lock bracket (5) with the screw (4), on the inside of the door.
5. Repeat steps 3 on page 83 and 4 to install the second lock on the back rack door.
6. Install a security slide bar on the right side of the rack.

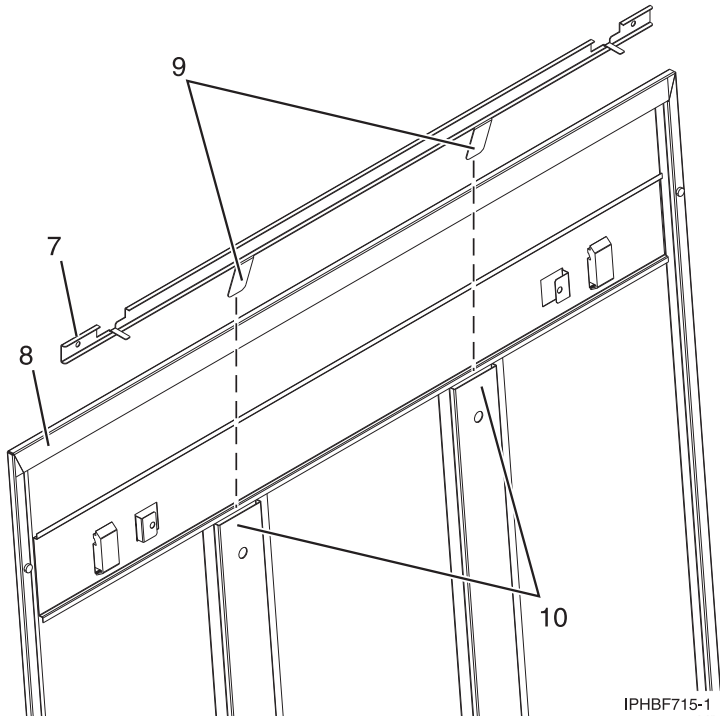

Figure 77. Installing a security slide bar

Note: Each slide bar rail has two long tabs on the bottom of the rail. The slide bar rails are identical and can be installed on either the right or left side cover panel.

- a. Unlatch right-side cover panel and lean the panel back so that you can access the top of the panel.
- b. With the flat side of the slide bar rail (7) in Figure 77, facing the inside of the cover panel (8), insert the two tabs (9), on the slide bar rail into the two vertical support channels (10) on the side cover panel.

Note: When installed correctly, the slide rail moves from front to back.

- c. Reinstall the side panel cover on to the rack.
- d. Lock the side panel covers by sliding the bars to the front of the rack.
- e. Place a locked/unlocked sticker on the inside of the cover panel so that when the slide bar is in the locked position, the tab is over the locked symbol (11), as shown in Figure 78 on page 86, and over the unlocked symbol (12), when the slide bar is unlocked.

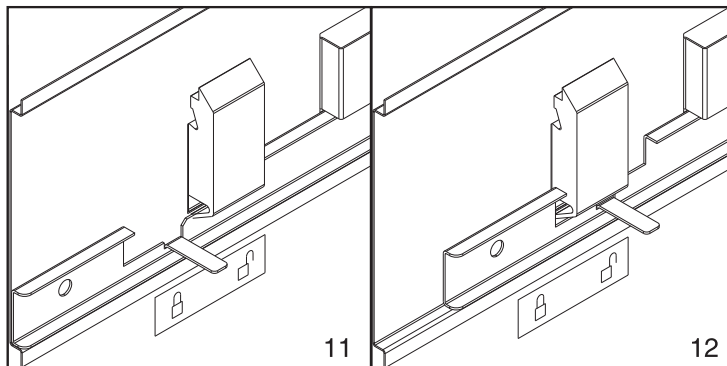

IPHBF716-1

Figure 78. Placing the locked/unlocked sticker on the cover panel

- f. Repeat the procedure for the left side of the rack.

Chapter 9. Ruggedized kit

You might need to remove or replace a part in the ruggedized kit. This section includes procedures so that you can perform these tasks.

The ruggedized kit, feature code 6080, should be ordered at the same time the rack is ordered. The ruggedized kit brackets are installed at the manufacturer.

Note: If you are installing a rack with the ruggedized kit and need to secure the rack to the floor, refer to Chapter 3, “Installing the rack,” on page 5.

The following illustration highlights the contents of the kit and the approximate location of each bracket and hinges in the event that you need to uninstall and reinstall a part.

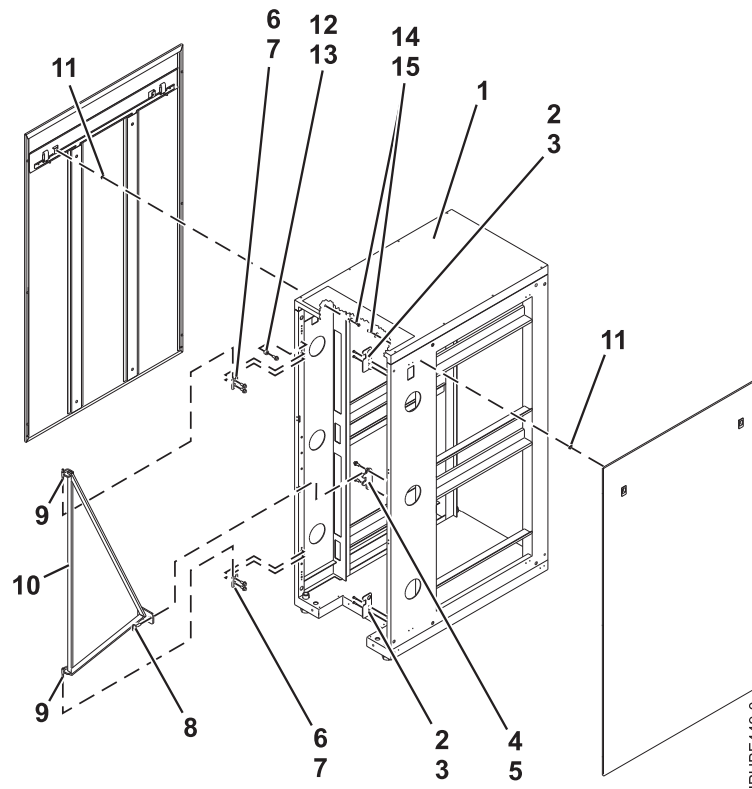

Figure 79. Ruggedized kit parts

- | | |
|------------------------------|--|
| 1 Rack | 9 Brace hinges |
| 2 Spacer | 10 Brace |
| 3 Brace hinge | 11 Side-door securing screw mount |
| 4 Hinge pivot studs | 12 Spacer |
| 5 Brace latch bracket | 13 Screw |
| 6 Spacer | 14 Washer |
| 7 Screw | 15 Side door securing screw |
| 8 Brace thumbscrew | |

Releasing the ruggedized brace

You might need to release the ruggedized brace. Use the procedure in this section to perform this task.

To access the back of a system that is installed in a rack with a ruggedized kit, complete the following steps to release the ruggedized brace:

1. Remove the brace thumbscrew (8).

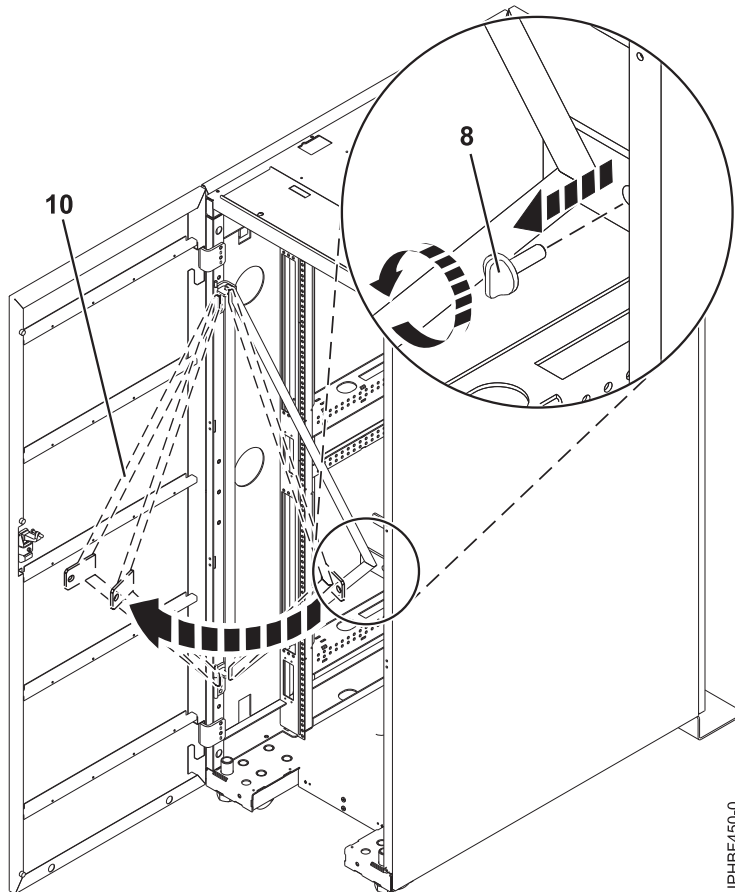

Figure 80. Releasing the brace to access systems

2. Swing the brace (10) out of the rack.
3. Access the system and reinstall the brace.

Releasing the side panel with a ruggedized kit

You might need to release the side panel on the rack. Use this procedure to perform this task.

The ruggedized kit contains securing screws that secure the side panels to the rack. To remove a securing screw, complete the following steps:

1. If necessary, open or remove the back rack door.
2. Locate the securing screw mount (11) for the side door that will be removed.

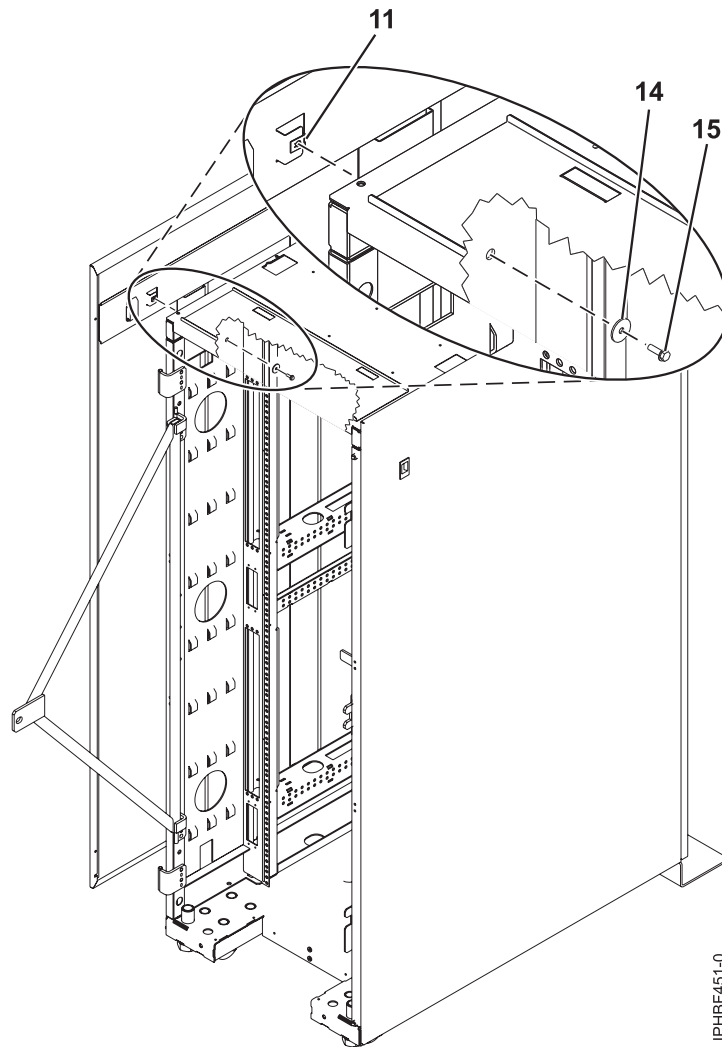

IPHBF451-0

Figure 81. Removing the securing screws on the side panel

3. Using a screwdriver, remove the securing screw (15) and washer (14) from the side panel. To remove the side panel, see Chapter 5, “Removing and replacing 7014-T00 or 7014-T42 side panels,” on page 75.

Chapter 10. Connecting multiple racks with rack-to-rack attachment kit

You might need to connect multiple racks together. Use the procedure in this section to perform this task.

This topic describes how to connect multiple racks to each other using a rack-to-rack attachment kit. To do this, you will need the rack-to-rack attachment kit (feature 7840).

To connect multiple racks with the rack-to-rack attachment kit follow this procedure:

1. Read the "Rack safety notices" on page 80.
2. If they are installed, remove the side panels from each rack. Remove side panels only from the sides that will be attached to each other. To do this:
 - a. Lift up the two panel-release tabs.
 - b. Pull the panel up and away from the rack chassis. This motion will release the panel from the two lower J brackets.
 - c. Store the side panels.
3. Remove the two Z brackets and the two J brackets. These brackets are used to hang the side panels.
4. Install the first two standoffs in the upper-left and lower-right corners of the first rack as shown in Figure 82 on page 92.
5. Install the second two standoffs in the upper-left and lower-right corners of the second rack as shown in Figure 82 on page 92.
6. Attach the long foam as shown in Figure 82 on page 92. For a model T42 rack, join the short foam to the end of the long foam, and adhere it to the frame length of the rack.
7. Position the racks together.
8. Align the standoff holes. You might need to adjust the leveling feet to do this.
9. Install a screw and washer into all four positions, but do not tighten.

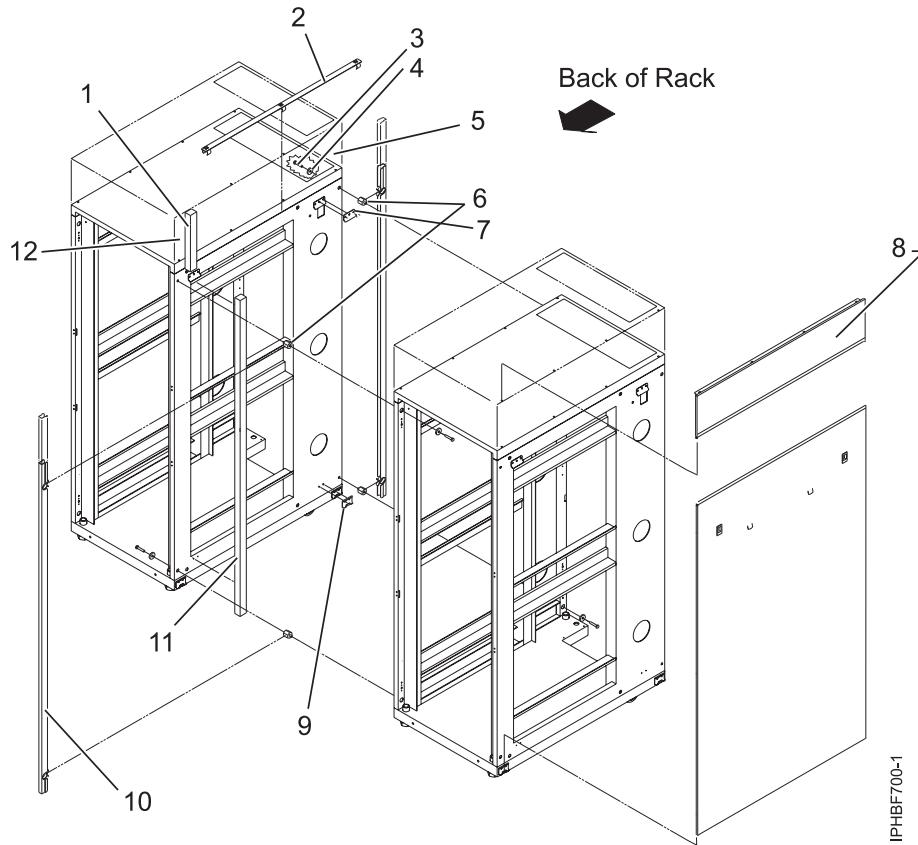

Figure 82. Removing the side panels, Z and J brackets, and installing standoffs and long foam to connect multiple racks

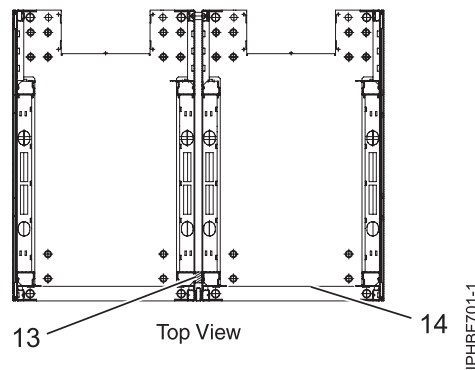

Figure 83. Location of foam strips (top view)

10. After all racks are bolted together, level the racks.
11. Tighten all four screws.
12. Snap on the trim pieces that go between the front and back racks.
13. Snap on the trim piece that goes on top and between the racks.
14. Install rack filler panels to cover the open areas at the front of the racks. All the gaps in the front of the rack must also be sealed, including the gaps between equipment. This step ensures that proper airflow within the rack is maintained.
15. Connect the cables that go between the racks.

16. If you are installing tip plates, go to step 5 in Chapter 3, “Installing the rack,” on page 5.

Chapter 11. Rack status beacon

The rack status beacon is placed on top of a rack and cabled to multiple system units inside the rack. The server firmware illuminates the rack status beacon in response to any detected problems in the status. This helps you locate the problem more quickly.

This is a customer task. You can perform this task yourself, or contact an service provider to perform the task for you. The service provider might charge you for this service.

These procedures assume that the system units have been installed into the rack and have been connected to the power supply. If the system units have not been installed, refer to the installation instructions for your system unit.

Installing the rack status beacon

You might need to install the rack status beacon. Use the procedure in this section to perform this task.

To install the rack status beacon, you need the following:

- Rack status beacon assembly.
- Two or more rack status beacon cables. You need one cable to connect the beacon to the junction box and one for each system unit that you want to connect to the beacon.
- One or two power cords.
- One or more junction boxes for the rack status beacon.
- One or more junction box cables.

To install the rack status beacon, follow these steps:

1. Place the rack status beacon (**A**), on top of the rack so that the light is pointing to the front of the rack.

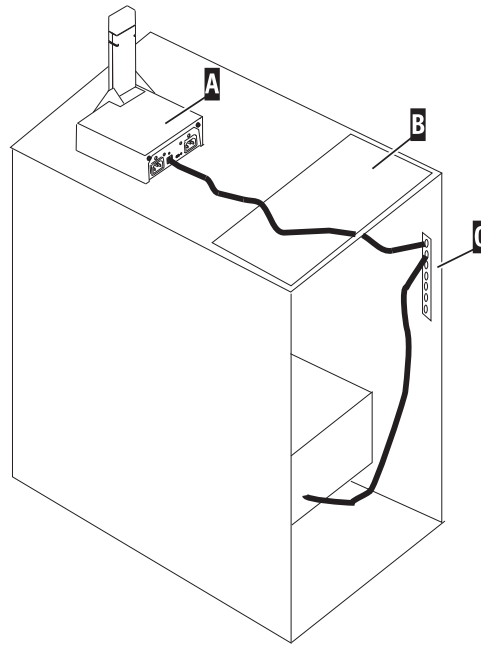

- A** Rack Beacon
- B** Cable Access Cover
- C** Junction Box

IPHBF702-0

Figure 84. Connecting the rack status beacon to the system unit through the junction box

2. Plug one end of the rack status beacon cable (1) into the port on the back of the rack status beacon assembly.

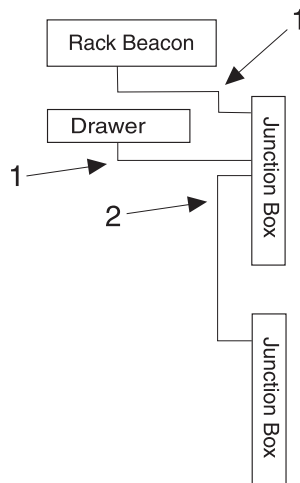

IPHBF703-0

Figure 85. Connecting the rack status beacon and system unit to the junction box

3. Thread the rack status beacon cable through the rack's cable access cover, (B).
4. Plug the other end of the rack status beacon cable into the output port on the junction box, (C).
5. To connect the junction box to the system unit, plug one end of a rack status beacon cable (1), into an input port on the junction box.

6. Plug the other end of the second rack status beacon cable into the beacon port on the system unit. This port is labeled with a beacon symbol.

Note: On some system units, the orientation of the port is rotated.

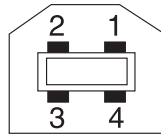

IPHBF704-0

Figure 86. Rack status beacon port

7. To add additional system units to this rack status beacon, repeat steps 4 and 5 for each additional system unit. You can connect multiple junction boxes to add additional system units. Refer to “Connecting multiple junction boxes.”
8. Plug the power cords into the rack status beacon assembly. Only one power cord is required, but you can use two power cords for backup.
9. Plug the other end of the power cords into the rack power supply.

If you install the rack status beacon during initial system setup, the initial program load (IPL) will read the rack identification information. If you install the rack status beacon on system units that are running, you will need to start the system again.

Connecting multiple junction boxes

You might need to connect multiple junction boxes. This section includes procedures so that you can perform these tasks.

You can connect multiple junction boxes so that additional system units can be added to the rack status beacon.

To connect multiple junction boxes, you need the following additional equipment:

- One or more rack status beacon junction boxes.
 - One or more junction box cables. You need a junction box cable for each junction box that you want to add.
1. Plug the one end of the junction box cable (2), into an input port on the first junction box.

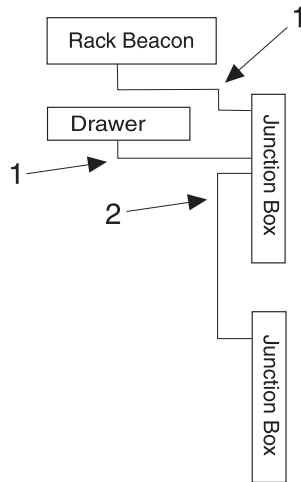

IPHBF703-0

Figure 87. Connect the rack status beacon and system unit to the junction box

2. Plug a junction box cable into the output port of the additional junction box.
3. Connect additional system units to the additional junction box as described in “Installing the rack status beacon” on page 95.
4. Repeat steps 1 - 3 for each additional junction box.

Chapter 12. Installing or removing a rack-mounted system-unit latch bracket

You might need to install or remove a latch bracket. Use the procedure in this section to perform this task.

These procedures describe how to install or remove the rack-mounted system-unit latch bracket. You can perform this task yourself, or contact a service provider to perform the task for you. The service provider might charge you for this service.

To install or remove a latch bracket, complete the following steps:

Note: The illustrations in these procedures may differ from your machine type and model.

1. Read the “Rack safety notices” on page 80.
2. Open the front rack door.
3. Push the latch bracket (A) or (B) into place on the side of the system unit.

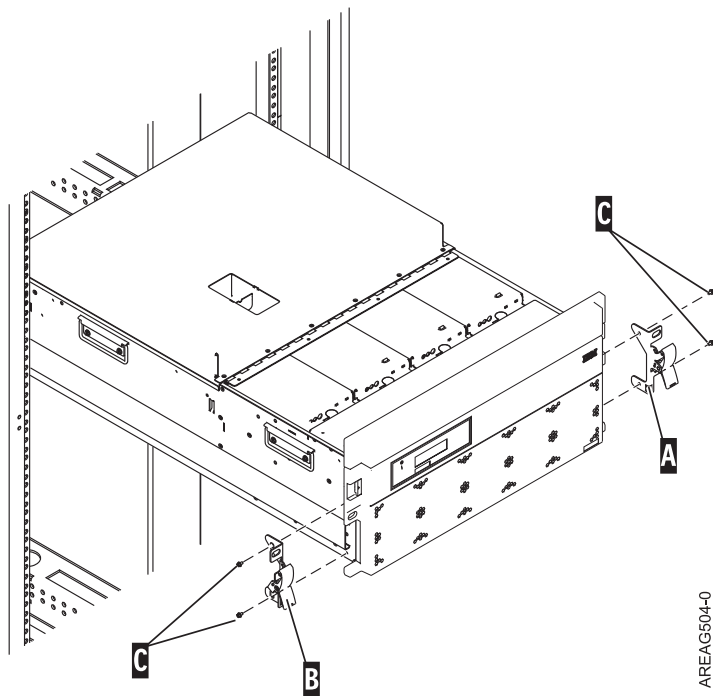

Figure 88. Reinstalling the latch brackets

4. Secure the latch bracket with two retaining screws (C) on the side of the latch bracket.
5. Replace the front cover. See Chapter 16, “Removing and replacing covers on the 8233-E8B or 8236-E8C system,” on page 121.
6. Close the front rack door.

To remove a latch bracket, complete the following steps:

1. Remove the cover from the front of the system. See Chapter 16, “Removing and replacing covers on the 8233-E8B or 8236-E8C system,” on page 121.
2. Place the system in the service position. See the service information for your model.

3. Remove the retaining screws (C) located on the side of the latch bracket (A) or (B).

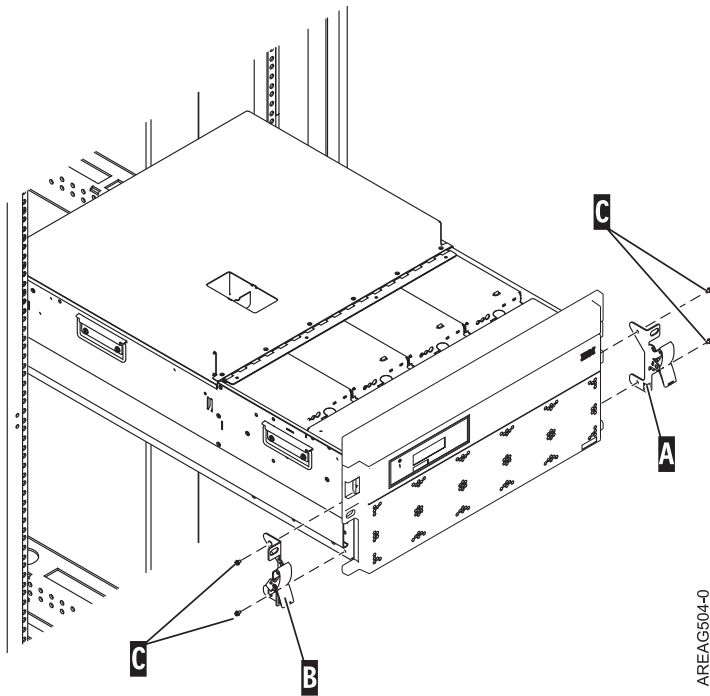

Figure 89. Removing the retaining screws

4. Remove the latch bracket from the system unit.

Chapter 13. Removing and replacing the rack top cover

You might need to remove or replace the rack top cover. Use these procedures to perform these tasks.

Removing the rack top cover

You might need to remove the rack top cover. Use this procedure to perform this task.

Note: A 10 mm box socket with an extension bar is required to remove the screws from the top cover. Other tools might cause the screw heads to become rounded and unremovable.

To remove the rack cover from the rack, do the following steps:

1. Remove the front door.

Note: If the rack is locked, unlock the doors. Then unlock the side panels by removing the locking bars from both sides of the top rear of the rack. Slide the locking bars out from the rack at the top of each side of the rack from the rear. The locking bars can be removed from each side of the front of the rack if the rack space in the locking bars area is open and the bars are easily accessible.

2. Remove the top, left, and right trim panels.
3. Remove the side panels. For more information, see Chapter 5, "Removing and replacing 7014-T00 or 7014-T42 side panels," on page 75.
4. Remove one screw from the right side of the top cover and one screw from the left side of the top cover. Do for both front and rear.
5. Locate the front **(A)** and back **(C)** rack braces that were provided in the shipping container. Fasten each rack brace at the top of the front and rear of the rack, just below the top cover.
6. Use the four screws **(B)** that were removed from the top cover to secure each rack brace to the rack, as shown in Figure 90 on page 102.

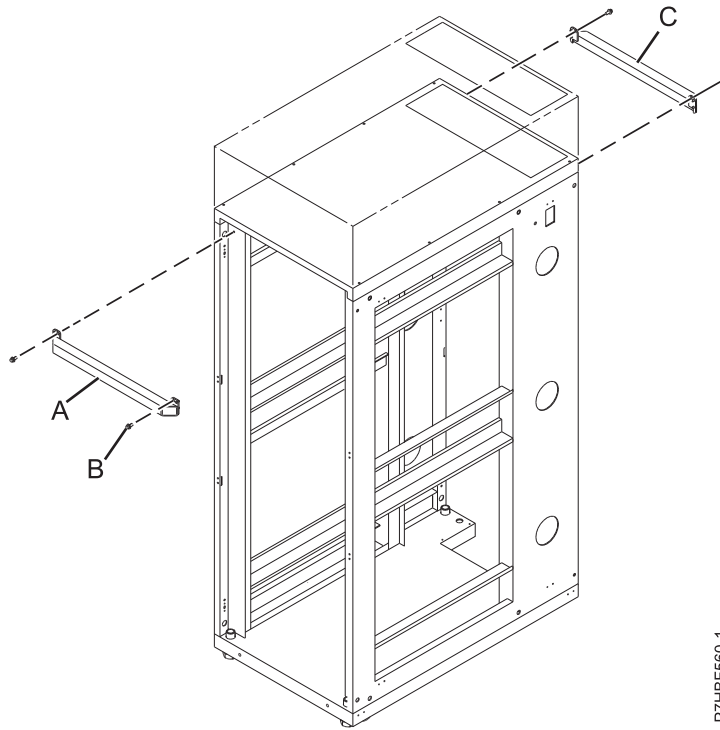

P7HBF560-1

Figure 90. Securing the rack brace

- A Front rack brace
- B Retaining screws (2 screws for each brace)
- C Back rack brace

7. Remove the remaining six screws from the left and right sides of the top cover (D).

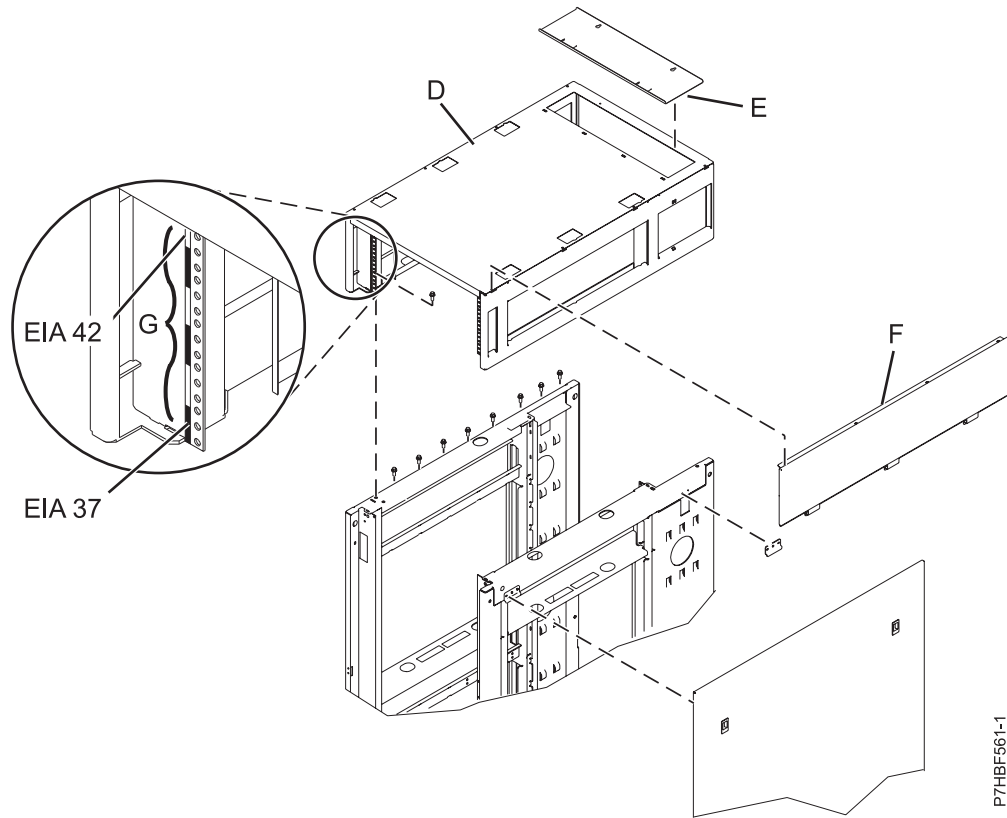

Figure 91. Removing the top cover

- D Top cover
- E Cable access cover
- F Side cover (quantity 2)
- G EIA label

8. Lift off the top cover.

Replacing the rack top cover

You might need to replace the rack top cover. Use this procedure to perform this task.

Note: A 10 mm box socket with an extension bar is required to replace the screws into the rack top cover. Other tools might cause the screw heads to become rounded and unable to be removed again.

To replace the rack top cover onto the rack, do the following:

1. Position the rack top cover (**D**) on the rack.
2. Install the six screws at the left and right sides of the rack top cover.

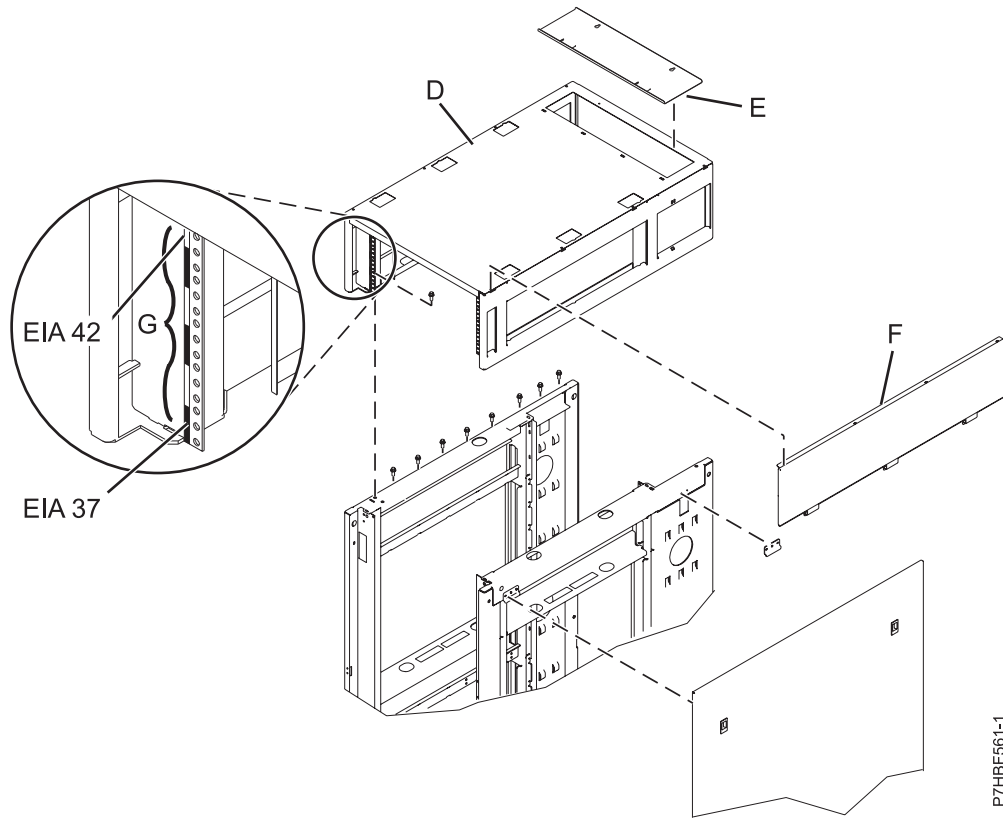

P7HBF561-1

Figure 92. Removing the top cover

- D Top cover
- E Cable access cover
- F Side cover (quantity 2)
- G EIA label

Note: A 10 mm box socket with an extension bar is required to replace the screws into the rack top cover. Other tools might cause the screw heads to become rounded and unable to be removed again.

3. Remove the rack braces (A) and (C) by unfastening them at the top of the rack, just below the top cover. Remove the braces at the front and rear of the rack.

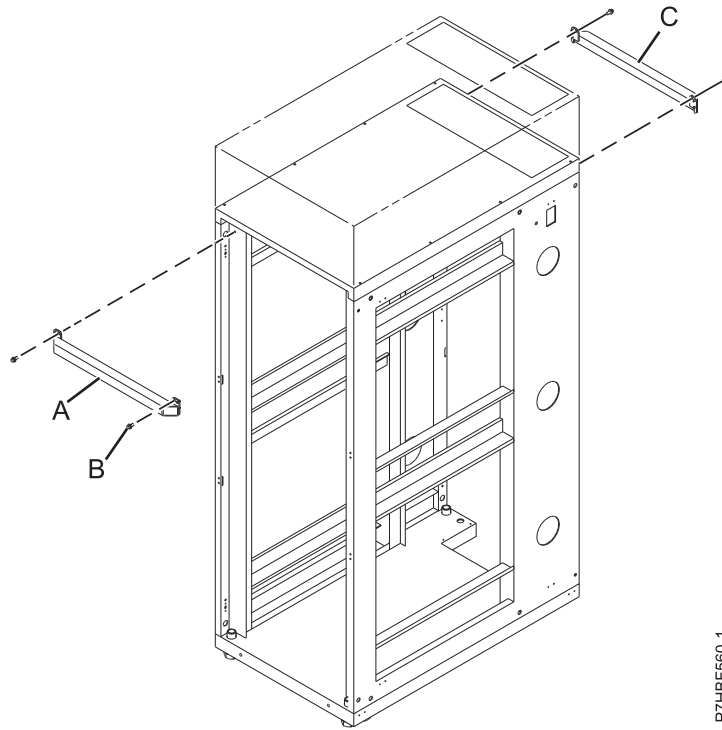

P7HBF560-1

Figure 93. Removing the top cover

- A Front rack brace
- B Retaining screws (quantity 2 for each brace)
- C Back rack brace

4. Install the screws (B) you removed from the rack braces at the right and left side of the top cover. Install the screws for both the front and rear of the rack.
5. Install rack filler panels to cover open areas at the front of the rack. Seal all gaps in the front of the rack, including the gaps between pieces of equipment. This step ensures that proper airflow within the rack is maintained.

Chapter 14. Power distribution unit plus

The power distribution unit plus (PDU+) can be installed in the 7014-T00 and 7014-T42 racks. It allows you to monitor the individual power loads of the devices that are plugged into it.

Installing the PDU+ in the side of a rack

Learn how to install the power distribution unit plus (PDU+) in the side of a rack.

Tip: Removing the rack doors and side panels might make installation easier.

Important: You must use clip nuts to install the mounting brackets. Clip nuts are provided with the PDU+ and install on the rack-mounting flanges.

To install the PDU+ in the 1U mounting space in the side of a rack, complete the following steps

1. Read the "Rack safety notices" on page 80.
2. Align the vertical-mounting brackets to the front of the PDU+. Make sure that you attach the brackets so that the power outlets face the rear of the rack.

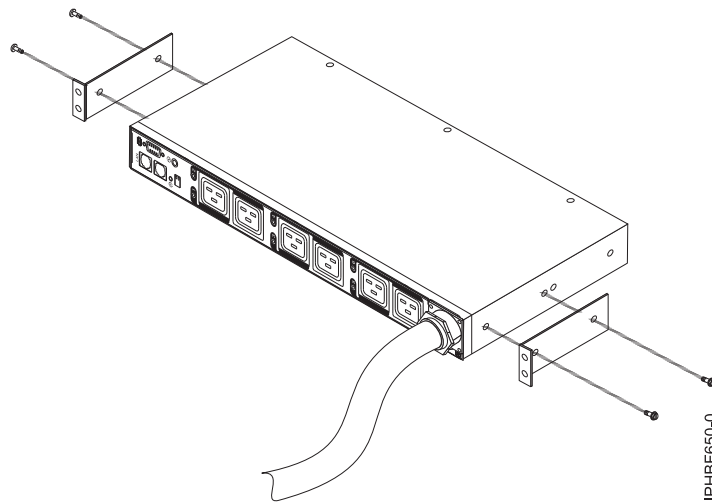
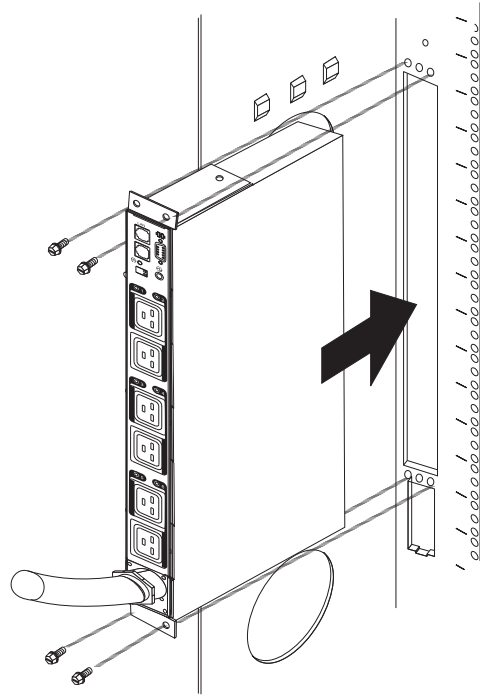

Figure 94. Aligning the vertical-mounting brackets to the front of the PDU+

3. Attach the brackets to the PDU+ with two M3x5 screws per bracket. Use the screws that were provided with the PDU+.
4. Align the PDU+ with the opening in the side of the rack. Then, while holding the PDU+ in place, attach the brackets to the rack-mounting flanges with four clip nuts and four M5 screws that were provided with the PDU+.



IPHBF651-0

Figure 95. Aligning the PDU+ with the opening in the side of the rack

Attention: You must disconnect the main input power before connecting or disconnecting the input power cord from the PDU+.

5. If the PDU+ was provided with a detached power cord, connect the power cord now. Align the connector on the power cord that was provided with the PDU+ with the connector on the front of the PDU+, turning as necessary for key alignment. Then, turn the twist-lock on the connector clockwise until it locks into place.

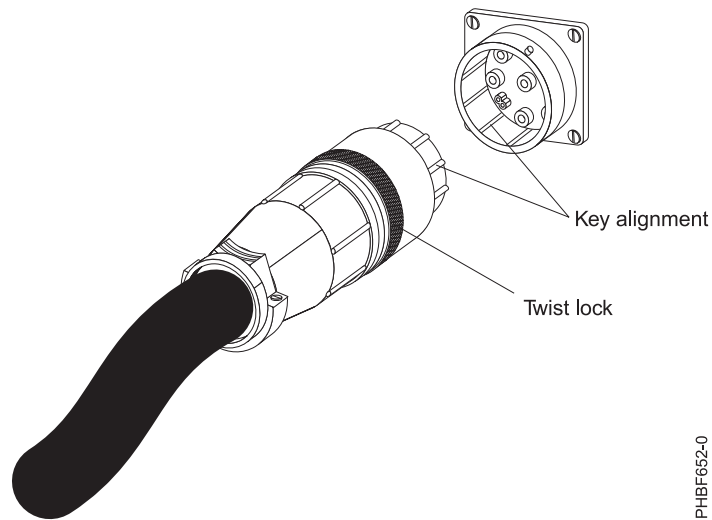

IPHBF652-0

Figure 96. Aligning the connector on the power cord with the PDU+

6. Route the power cord from the PDU+ toward the rack side braces. Then, route the power cord along a side brace toward the back of the rack and secure the power cord with the cable straps that are provided with the PDU+.
7. Route the power cord toward a dedicated power source. Use the provided cable straps to secure the power cord along the way. Use the openings in the rack, if the power cord must exit the rack to connect to a power source.

Attention: To prevent damage to a power device and other connected devices, always connect the power device to an authorized power source for that device.

8. Connect the power cord to a properly wired and grounded dedicated power source. Then, you can connect servers or rack PDUs in the rack to the power outlets on the PDU+.
9. Route all of the other power cables neatly and secure the power cables with cable straps.

Related concepts

“Setting up power monitoring using the PDU+” on page 113

You can monitor the power status for any device that is connected to the power distribution unit plus (PDU+), either manually or remotely, through the PDU+ Web interface. You can use the IBM DPI® Configuration Utility to initially set up the PDU+ and to configure PDU+ settings such as network parameters, access control table, and trap receivers table.

Installing the PDU+ horizontally in a rack

You might need to install the PDU horizontally, use the instructions in this section to complete this task.

Tip: Removing the rack doors and side panels might make installation easier.

Important: Use cage nuts for rack cabinets with square holes, and use clip nuts for rack cabinets with round holes. If your rack cabinet requires cage nuts, use a cage-nut-insertion tool or a flat-blade screwdriver to install them..

To install the PDU+ in the rack, complete the following steps

1. Read the “Rack safety notices” on page 80.
2. Align the vertical-mounting brackets to the front of the PDU+. Make sure that you attach the brackets so that the power outlets face the rear of the rack.

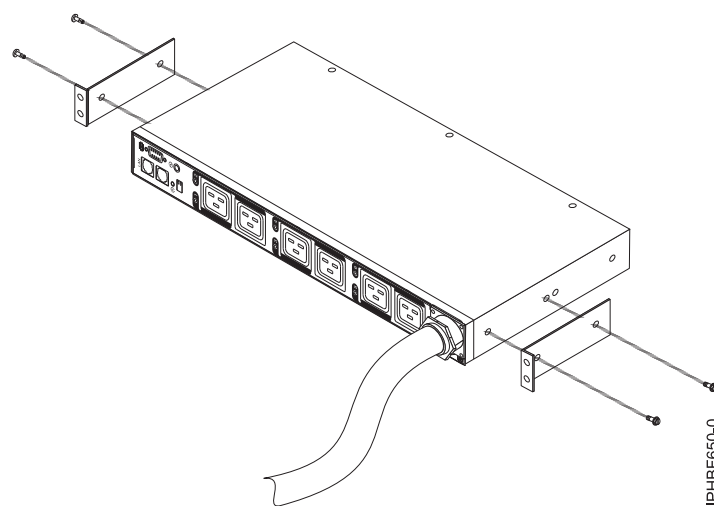
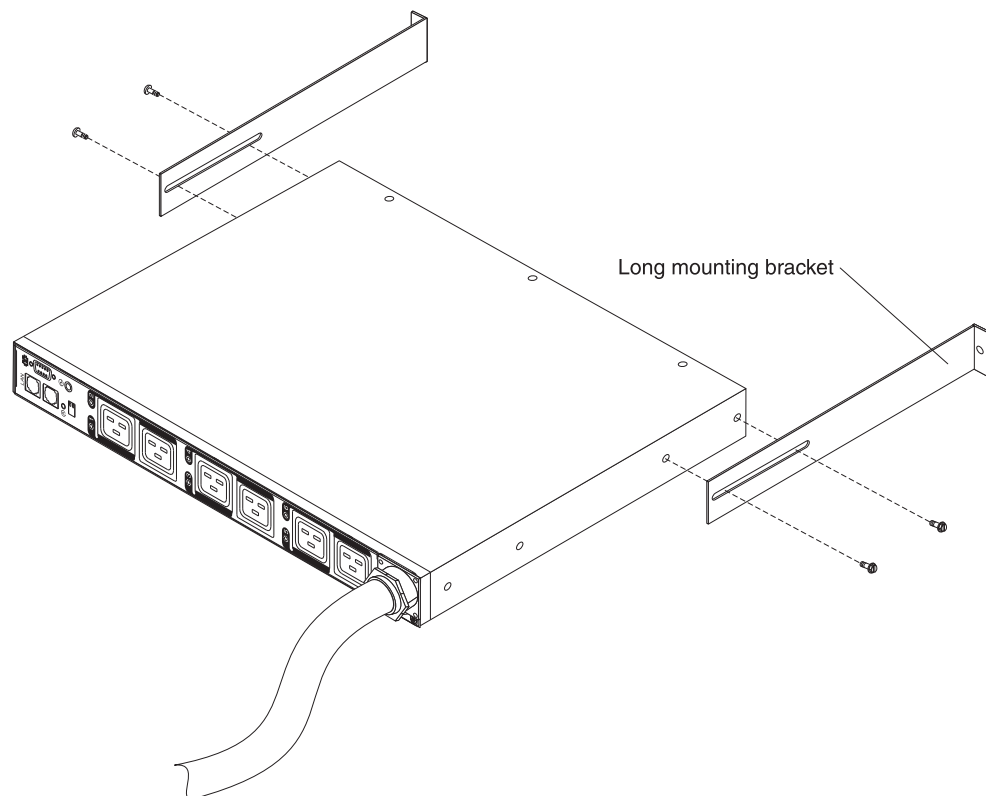

Figure 97. Aligning the vertical-mounting brackets to the front of the PDU+.

3. Align the long mounting-brackets with the holes in the rear of the PDU+ and attach the brackets to the PDU+ with two M3 pan-head screws with captive lock washers per bracket. Use the screws that

come with the rack-mounting kit.



4. Hold the PDU+ at a slight angle and carefully insert it into the 1-U mounting space in the rack cabinet. Pushing in slightly on both of the long mounting-brackets helps clear the brackets from the rack flanges.

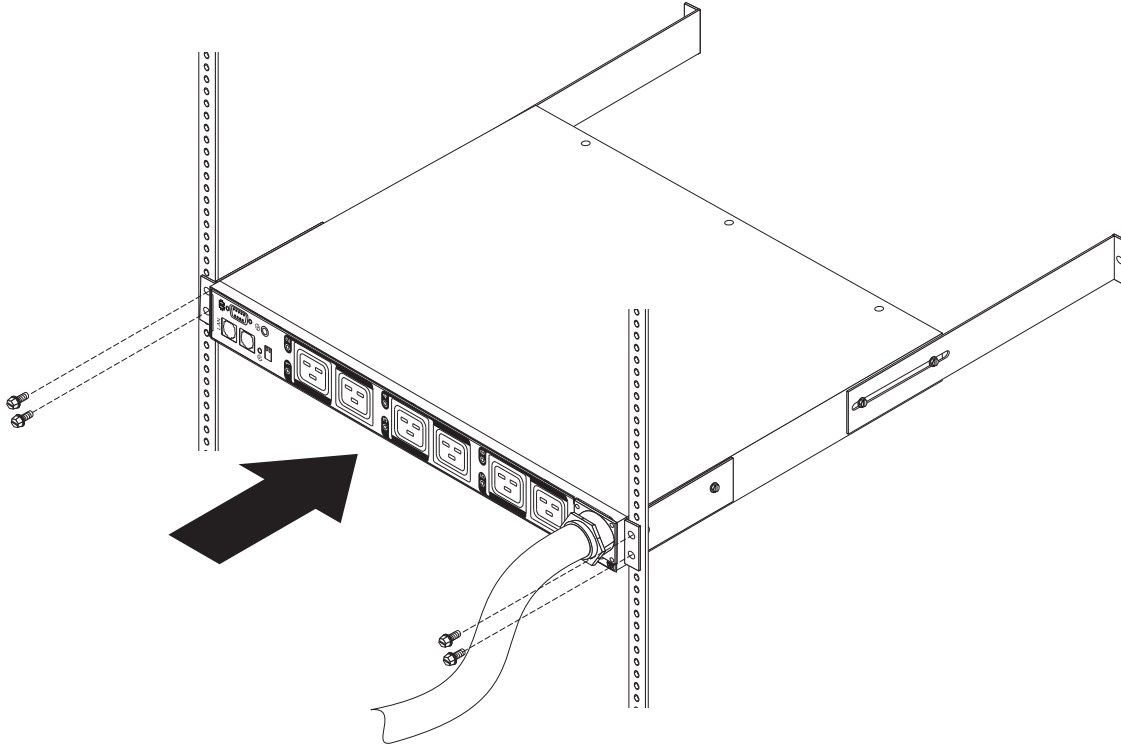
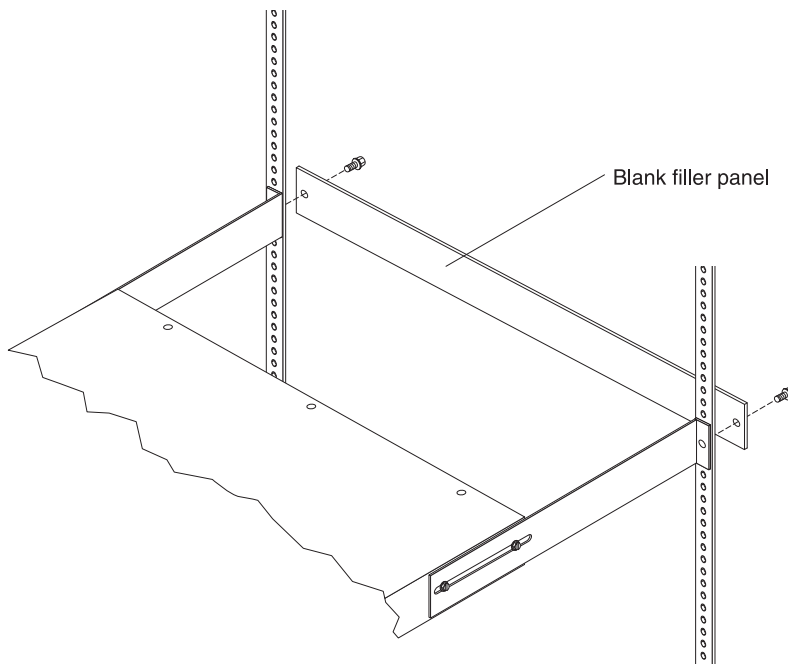

Figure 98. Aligning the PDU+ with the opening in the rack.

Attention: You must disconnect the main input power before connecting or disconnecting the input power cord from the PDU+.

5. Secure the end of the PDU+ that has the short mounting-brackets to the rack cabinet first. Make sure that the short mounting-brackets are aligned with the outside of the rack flanges. Attach the brackets to the rack flanges with two M6 screws and two cage nuts or clip nuts per bracket. Use the cage nuts or clip nuts and the screws that come with the rack-mounting kit.
6. Secure the long mounting-brackets and the 1-U blank filler panel to the rack cabinet by doing the following steps:



- a. Adjust the long mounting-brackets to fit the depth of the rack cabinet.
 - b. Make sure that the long mounting-brackets are aligned with the inside of the rack flanges.
 - c. Align the blank filler panel on the outside of the rack flanges.
 - d. Attach the filler panel to the rack flanges and then to the long mounting-bracket with one M6 screw per bracket.
 - e. Tighten the M3 pan-head screws that secure the long mounting-brackets to the PDU.
7. Secure the end of the PDU+ that has the short mounting-brackets to the rack cabinet first. Make sure that the short mounting-brackets are aligned with the outside of the rack flanges. Attach the brackets to the rack flanges with two M6 screws and two cage nuts or clip nuts per bracket. Use the cage nuts or clip nuts and the screws that come with the rack-mounting kit.
 8. If the PDU+ was provided with a detached power cord, connect the power cord now. Align the connector on the power cord that was provided with the PDU+ with the connector on the front of the PDU+, turning as necessary for key alignment. Then, turn the twist-lock on the connector clockwise until it locks into place.

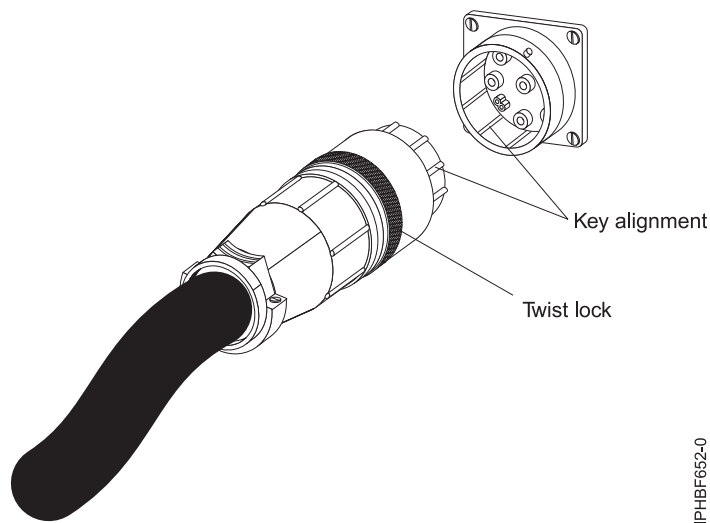

Figure 99. Aligning the connector on the power cord with the PDU+

9. Route the power cord from the PDU+ toward the rack side braces. Then, route the power cord along a side brace toward the back of the rack and secure the power cord with the cable straps that are provided with the PDU+.
10. Route the power cord toward a dedicated power source. Use the provided cable straps to secure the power cord along the way. Use the openings in the rack, if the power cord must exit the rack to connect to a power source.

Attention: To prevent damage to a power device and other connected devices, always connect the power device to an authorized power source for that device.
11. Connect the power cord to a properly wired and grounded dedicated power source. Then, you can connect servers or rack PDUs in the rack to the power outlets on the PDU+.
12. Route all of the other power cables neatly and secure the power cables with cable straps.

Setting up power monitoring using the PDU+

You can monitor the power status for any device that is connected to the power distribution unit plus (PDU+), either manually or remotely, through the PDU+ Web interface. You can use the IBM DPI Configuration Utility to initially set up the PDU+ and to configure PDU+ settings such as network parameters, access control table, and trap receivers table.

Note: All of the Configuration Utility configuration options are available through the Web interface after the PDU+ is set up on the local network.

Related tasks

“Installing the PDU+ in the side of a rack” on page 107

Learn how to install the power distribution unit plus (PDU+) in the side of a rack.

Using the IBM DPI Configuration Utility

Learn how to use the IBM DPI Configuration Utility to configure the power distribution unit plus (PDU+) settings, such as the IP address, network parameters, access control table, and trap receivers table.

Connecting the console

You can configure the PDU+ using a workstation or notebook computer that is connected to the PDU+. Connect the DB9-to-RJ-45 cable that is shipped with the PDU+ to the RJ-45 console connector on the PDU+, and to a RS-232 serial (COM) connector on a workstation or notebook computer.

Using HyperTerminal

HyperTerminal is a terminal program in a Microsoft® Windows® operating system that enables you to configure or control a device using command line parameters. You can configure the PDU+ parameters and its outlets using numeric commands from a keyboard. You can also use Telnet or any other terminal program to configure the PDU+ after the IP address is set.

To start HyperTerminal and communicate with the PDU+, complete the following steps:

1. Click **Start** → **Programs** → **Accessories** → **Communications** → **HyperTerminal**. The Connection Description window is displayed.
2. Type the name for the connection in the **Name** field and select an icon for the connection.
3. Click **OK**. The Connect To window is displayed.
4. In the **Connect using** field, select the COM port that is connected to the PDU+.
5. Click **OK**. The Properties window is displayed.
6. Click **Restore Defaults** to use the default settings. Make sure that the **Bits per second** field is 9600 and that the **Flow control** field is None.
7. Click **OK**.
8. Press any key. The Configuration Utility main menu is displayed.
9. Type the default password, passw0rd (all lowercase letters with a zero, not O), and press Enter.
10. Enter the menu option that you want. For descriptions of the options, see “Configuration Utility menu options.”

Configuration Utility menu options

The following options are on the Configuration Utility main menu:

IBM DPI Settings

When you select IBM DPI Settings, the IBM DPI Configuration Utility window is displayed with the following options:

Set the IP Address, Gateway Address and MIB System Group

View and change the IP address, date, time, and MIB system information.

Set IBM DPI Control Group

Set the administrator user name, password, and access protocols.

Set Write Access Managers

Set up a list of users who can access and control the PDU+.

Set Trap Receivers

Configure remote network management system (NMS) servers to receive traps.

Set Date and Time

Adjust the date and time information for the PDU+.

Set Superuser Name and Password

Set the user name and password of the administrator who will use a Web browser to configure the PDU+.

E-mail Notification

Set up a list of users who will be alerted with event messages if an unusual event is triggered on the PDU+ system.

Set Multi-Users

Configure other user and password logins and the read and write access levels.

Set IBM DPI Information

Configure the PDU+ logging interval, refresh rate, and custom name fields for the load groups.

Settings and Event Log Summary

View all PDU+ configuration settings.

Reset Configuration to Default

Reset all system settings to their factory default values.

Restart HD-PDU

Restart the PDU+.

Setting the IP address

Important: You must set the IP address before you can use the Web interface or access the PDU+ in an IP network (LAN/WAN). Contact your system administrator if you do not know the IP address.

To set the IP address, complete the following steps:

1. In the Configuration Utility main menu, enter the menu option for **IBM DPI Settings**.
2. Enter the menu option for **Set the IP Address, Gateway Address and MIB System Group**.

Using the Web interface

Learn how to use the Web interface to configure and monitor the power distribution unit plus (PDU+) remotely. The PDU+ provides a graphical user interface that you can view from a Web browser. Using a Web browser, you can access and monitor the PDU+ power outlets and output devices remotely from a workstation or notebook computer.

Starting the Web interface

To start the Web interface, complete the following steps:

1. Start a Web browser from a workstation or notebook computer, and enter the IP address of the PDU+ in the **address** field. The **Connect to** window is displayed.

Note: For more information about setting the IP address of the system, see "Setting the IP address."

2. In the **User name** field, type USERID (all uppercase letters).
3. In the **Password** field, type passw0rd (all lowercase letters with a zero, not O).
4. Click **OK**. The main status page is displayed.

The main status page displays a graphical representation of the PDU+ power outlets and input status:

- The left pane displays the menus and submenus for the PDU+. Click a menu to display the menu options, expand the menu items, and modify the menu options as required.
- The graphic displayed in the right pane shows the status of the outlets, input voltage, output voltage, frequency, current and power, watt-hour consumption, and cumulative kilowatt hour power consumption. If you connect an optional environmental monitored probe, the temperature and humidity environment conditions are displayed.

Each menu page provides online help to assist you with configuring the PDU+. Click the **Help** icon at the top of each page to view the help.

Modifying the basic settings

Use the System menu to configure the PDU+ system parameters such as the superuser name, password, IP address, date, and time.

Changing the superuser name and password:

You can set the user name and password of the administrator who will use a Web browser to configure the PDU+ on the Configuration Utility page.

To change the superuser name and password, complete the following steps:

1. From the main status page, in the left navigation pane, click **System**.
2. Click **Configuration** to view and modify the system configuration and superuser user name and password.

Identifying the PDU+ and Web/SNMP card:

You can view the PDU+ and Web/SNMP card information on the Identification of Power Management page.

To view the power management information of the PDU+ and Web/SNMP card, complete the following steps:

1. From the main status page, in the left navigation pane, click **System**.
2. Click **Identification** to view the PDU+ and Web/SNMP card information.

Adding users:

You can add users who can access and control the PDU+ on the Multi-User Configuration page.

To create a list of users who can access and control the PDU+, complete the following steps:

1. From the main status page, in the left navigation pane, click **System**.
2. Click **Multi-User** to add users who can only view the PDU+ status or users who can change the PDU+ settings.

Changing the date and time:

You can change the date and time of the PDU+ on the Date and Time page.

Important: Changing the PDU+ date and time affects other system settings such as e-mail, traps, and logs.

To change the date and time, complete the following steps:

1. From the main status page, in the left navigation pane, click **System**.
2. Click **Date and Time** to view and modify the system date and time. You can set the date and time manually, synchronize it with the computer time, or synchronize it with an NTP server.

Changing event alerts:

You can change event alerts on the SNMP Trap Receivers page.

To configure the PDU+ to send e-mail or SNMP trap alerts to specified users when specific events occur, complete the following steps:

1. From the main status page, in the left navigation pane, click **System**.
2. Click **Trap Receivers** to create a list of users or workstations who will be alerted with an SNMP trap message. You can specify the IP addresses of up to eight trap receivers, the community information, type of trap, severity of trap, and description of the events that cause the traps.

3. Click **Email Notification** under **System** to create a list of up to four users who will be alerted with an e-mail. Use this menu to specify the mail server, user account, DNS, and other information necessary to set up a mail server for sending mail alerts. Use the Email Receivers Table to add the e-mail addresses.

Changing the network information

Use the Network menu to change the network information for the PDU+, for example, the IP address.

Changing the network configuration:

You can view or change the network configuration on the Network Configuration page.

To view or change the network configuration of the PDU+, complete the following steps:

1. From the main status page, in the left navigation pane, click **Network**.
2. Click **Configuration** to set the PDU+ IP address, gateway address, subnet mask, and Domain Name System (DNS) address.
3. Click **Control** to configure TCP/IP settings.
4. Click **Access Control** to set access control to prevent unauthorized users from accessing the PDU+.

History and event log summaries

The Logs menu provides a detailed description of all events and a record of the PDU+ status. System administrators can use this page to analyze problems with network equipment.

Viewing the history log:

You can view the complete history of the PDU+ inputs and outputs on the History Log page.

To view the history of the PDU+, complete the following steps:

1. From the main status page, in the left navigation pane, click **Logs**.
2. Click **History**. Each event log file shows the time, date, and description of all the events occurring on the PDU+.

Viewing the event log:

You can view the complete record of the PDU+ events on the Event Log page.

To view the complete record of the PDU+ events, complete the following steps:

1. From the main status page, in the left navigation pane, click **Logs**.
2. Click **Events**. Each log file shows a record of the input power and output power of each outlet.

Chapter 15. Removing and replacing the expansion unit cover or door

You might need to remove, replace, or install covers or doors on an expansion unit as a part of accessing components or performing a service action.

Removing the front cover on the 7314-G30 or 5796

You might need to remove the front cover to perform service to the system.

To remove the front cover, follow these steps:

1. Remove the two thumbscrews (**B**) located on the left and right of the cover.

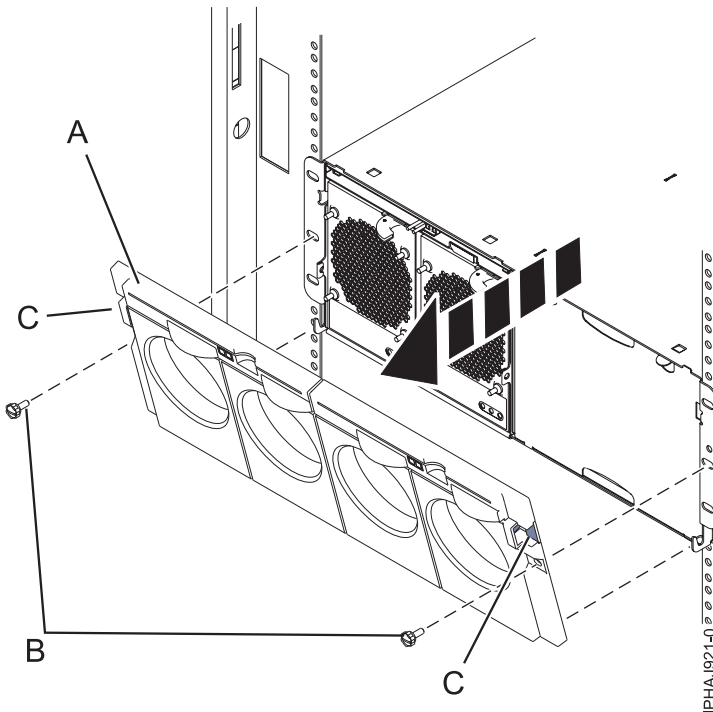

Figure 100. Remove the front cover for model 7314-G30 or 5796

2. Press in on the two latches (**C**) located left and right of the cover to release the cover.
3. Lift out the cover (**A**) and away from the chassis.

Tip: If an airflow block is present on an unpopulated side of the chassis do not remove it unless you are populating that side of the chassis.

Installing the front cover on the 7314-G30 or 5796

Use this procedure to install the front cover after installing the system or performing a service action.

If you only have one side of the chassis populated, ensure that the airflow block is present on the unpopulated side.

1. Insert the posts on the bottom of the cover (**A**) into the hooks on the chassis of the enclosure.
2. Press in on the two latches (**C**) on the right and left of the front cover.

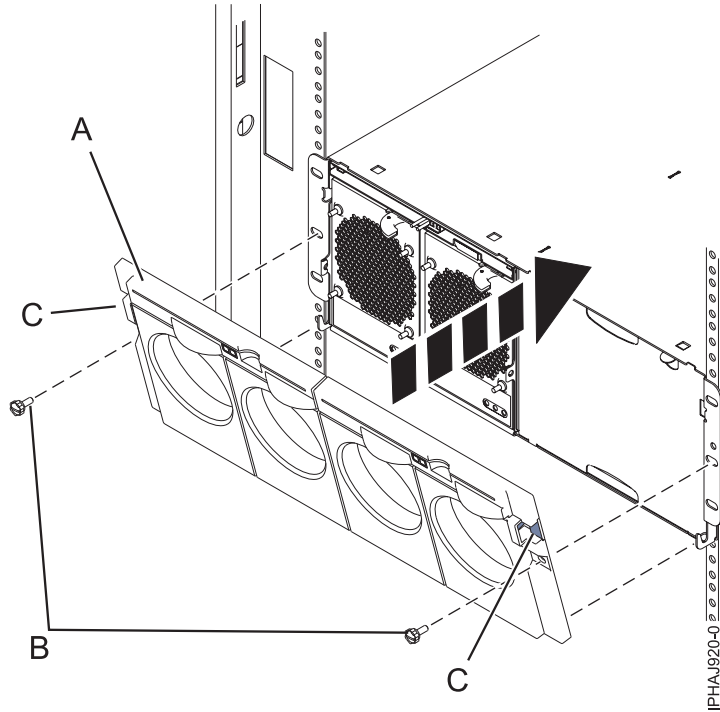

Figure 101. Front cover on a model 7314-G30 or 5796

3. Press the cover onto the chassis and release the latches. The cover securely snaps into place.
4. Replace the two thumbscrews (**B**) into the slots on the left and right of the front cover.

Chapter 16. Removing and replacing covers on the 8233-E8B or 8236-E8C system

Use these instructions to remove, replace, or install covers to access components or perform service.

Removing the service access cover from an 8233-E8B or 8236-E8C system

Use this procedure to remove the service access cover to perform service or to gain access to internal components.

To remove the service access cover, follow these steps:

1. Place the system into the service position. For instructions, see “Placing a 8233-E8B or 8236-E8C in the service position” on page 131.
2. Loosen the two thumbscrews (**A**) located at the back of the cover.
3. Slide the cover (**B**) toward the back of the system unit. When the front of the service access cover clears the upper frame ledge, lift the cover up and off the system unit.

Attention: For proper cooling and airflow, install the cover before starting the system. Operating the system without the cover for more than 30 minutes could damage the system components.

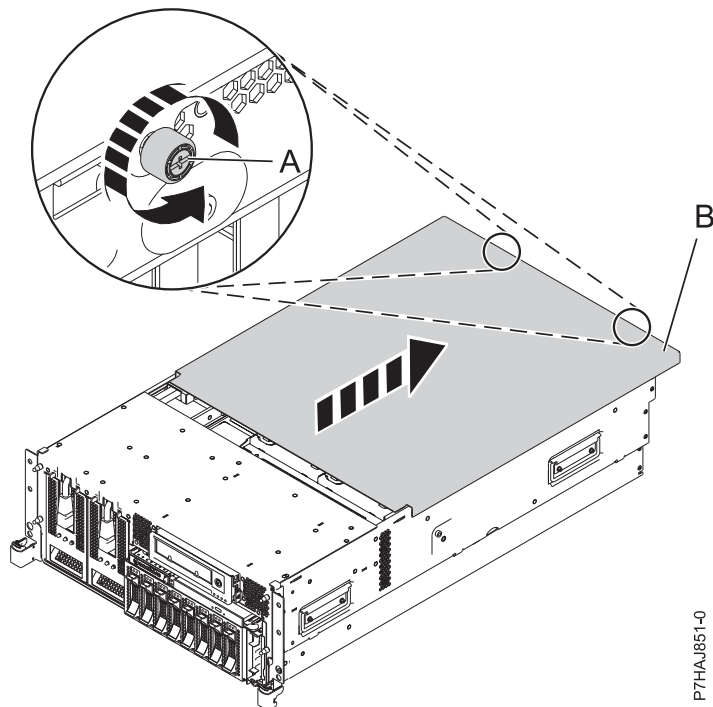

P7HAJ851-0

Figure 102. Removing the service access cover

Installing the service access cover on an 8233-E8B or 8236-E8C system

Use this procedure to install the service access cover after performing service or accessing internal components.

To install the service access cover, follow these steps:

1. Place the service access cover **(A)** on the top of the system unit, approximately 25 mm (1 in.) from the front of the system unit.
2. Hold the service access cover against the system unit, and slide it toward the front of the system.
The tabs on the service access cover slide beneath the upper chassis ledge, and the two screws align with the screw holes at the back of the system unit.

Important: Ensure that the fan LED cables do not get caught on the front edge of the service access cover as you move it forward.

3. Tighten the screws **(B)** located at the back of the cover.

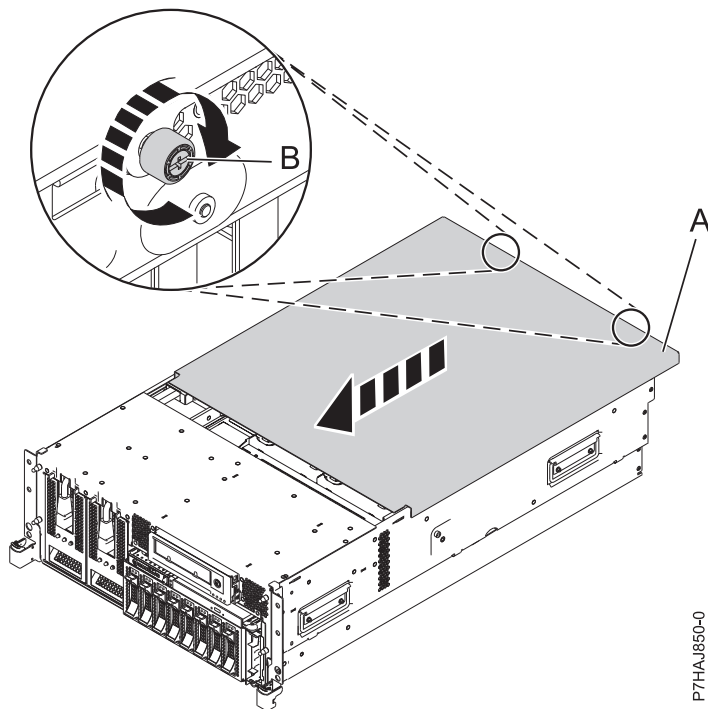

Figure 103. Installing the service access cover

Removing the front cover from an 8233-E8B or 8236-E8C system

Use this procedure to remove the cover to access components or perform service.

To remove the front cover, follow these steps:

1. Remove the two screws **(A)** that secure the system to the rack **(B)** as shown in the following figure.
2. Pull the cover away from the system. The cover has an indentation where you can hold onto it more easily.

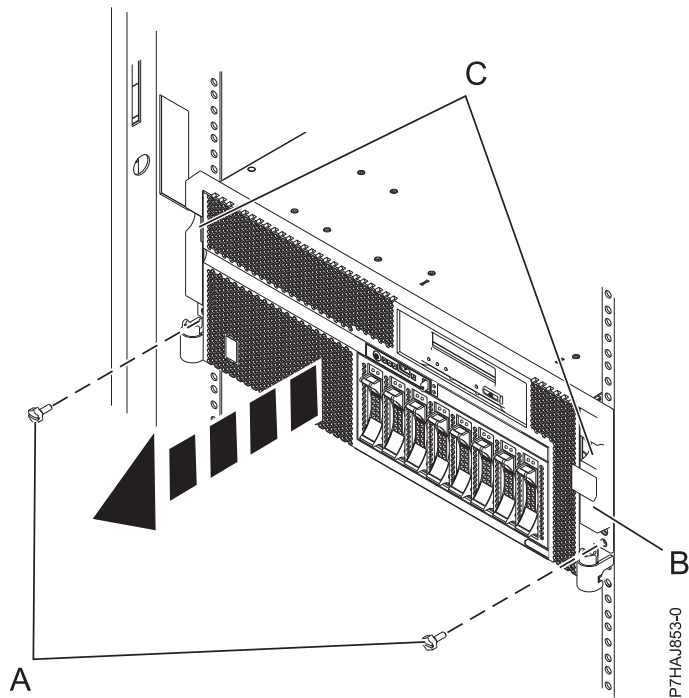

Figure 104. Removing the front cover

Installing the front cover on an 8233-E8B or 8236-E8C system

Use this procedure to install the cover after accessing components or performing service.

To install the front cover, follow these steps:

1. Align the cover with the system.
2. Gently push the cover in until the four cover clips are seated in their respective mounting posts (**B**) on the system.
3. Replace the two screws (**C**) that secure the system to the rack (**A**).

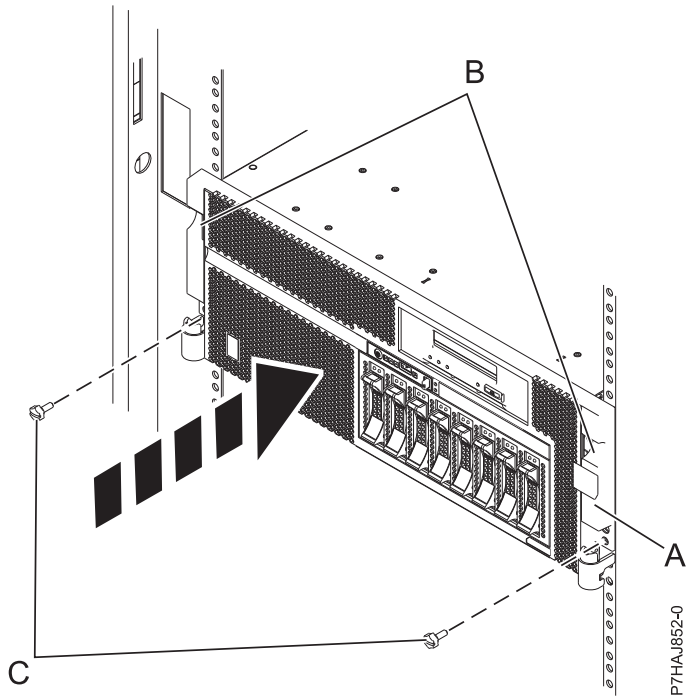

Figure 105. Installing the front cover

Installing the front cover on the 7314-G30 or 5796

Use this procedure to install the front cover after installing the system or performing a service action.

If you only have one side of the chassis populated, ensure that the airflow block is present on the unpopulated side.

1. Insert the posts on the bottom of the cover (A) into the hooks on the chassis of the enclosure.
2. Press in on the two latches (C) on the right and left of the front cover.

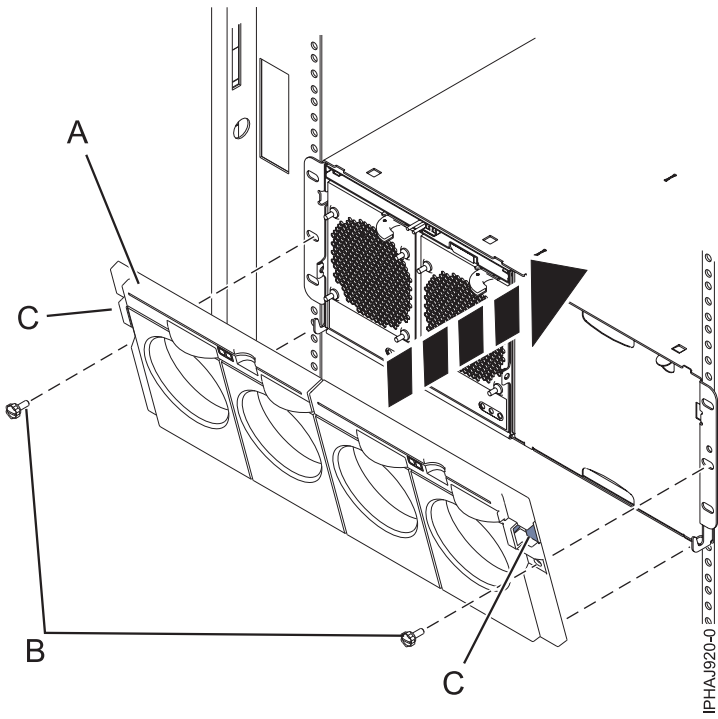

Figure 106. Front cover on a model 7314-G30 or 5796

3. Press the cover onto the chassis and release the latches. The cover securely snaps into place.
4. Replace the two thumbscrews **(B)** into the slots on the left and right of the front cover.

Chapter 17. Placing the rack-mounted 8233-E8B or 8236-E8C system into the service position or operating position

Use these procedures to place a system into the service position or operating position to perform service or to gain access to internal components.

Placing the rack-mounted system or expansion unit in the service position

Use this procedure to perform service or gain access to internal components by placing the rack-mounted system or expansion unit in the service position.

Note: Some of the figures in these procedures might not look exactly like the system or expansion unit that you have. However, the steps to perform the task are the same.

DANGER

When working on or around the system, observe the following precautions:

Electrical voltage and current from power, telephone, and communication cables are hazardous. To avoid a shock hazard:

- Connect power to this unit only with the IBM provided power cord. Do not use the IBM provided power cord for any other product.
- Do not open or service any power supply assembly.
- Do not connect or disconnect any cables or perform installation, maintenance, or reconfiguration of this product during an electrical storm.
- The product might be equipped with multiple power cords. To remove all hazardous voltages, disconnect all power cords.
- Connect all power cords to a properly wired and grounded electrical outlet. Ensure that the outlet supplies proper voltage and phase rotation according to the system rating plate.
- Connect any equipment that will be attached to this product to properly wired outlets.
- When possible, use one hand only to connect or disconnect signal cables.
- Never turn on any equipment when there is evidence of fire, water, or structural damage.
- Disconnect the attached power cords, telecommunications systems, networks, and modems before you open the device covers, unless instructed otherwise in the installation and configuration procedures.
- Connect and disconnect cables as described in the following procedures when installing, moving, or opening covers on this product or attached devices.

To Disconnect:

1. Turn off everything (unless instructed otherwise).
2. Remove the power cords from the outlets.
3. Remove the signal cables from the connectors.
4. Remove all cables from the devices

To Connect:

1. Turn off everything (unless instructed otherwise).
2. Attach all cables to the devices.
3. Attach the signal cables to the connectors.
4. Attach the power cords to the outlets.
5. Turn on the devices.

(D005)

DANGER

Observe the following precautions when working on or around your IT rack system:

- Heavy equipment—personal injury or equipment damage might result if mishandled.
- Always lower the leveling pads on the rack cabinet.
- Always install stabilizer brackets on the rack cabinet.
- To avoid hazardous conditions due to uneven mechanical loading, always install the heaviest devices in the bottom of the rack cabinet. Always install servers and optional devices starting from the bottom of the rack cabinet.
- Rack-mounted devices are not to be used as shelves or work spaces. Do not place objects on top of rack-mounted devices.



- Each rack cabinet might have more than one power cord. Be sure to disconnect all power cords in the rack cabinet when directed to disconnect power during servicing.
- Connect all devices installed in a rack cabinet to power devices installed in the same rack cabinet. Do not plug a power cord from a device installed in one rack cabinet into a power device installed in a different rack cabinet.
- An electrical outlet that is not correctly wired could place hazardous voltage on the metal parts of the system or the devices that attach to the system. It is the responsibility of the customer to ensure that the outlet is correctly wired and grounded to prevent an electrical shock.

CAUTION

- Do not install a unit in a rack where the internal rack ambient temperatures will exceed the manufacturer's recommended ambient temperature for all your rack-mounted devices.
- Do not install a unit in a rack where the air flow is compromised. Ensure that air flow is not blocked or reduced on any side, front, or back of a unit used for air flow through the unit.
- Consideration should be given to the connection of the equipment to the supply circuit so that overloading of the circuits does not compromise the supply wiring or overcurrent protection. To provide the correct power connection to a rack, refer to the rating labels located on the equipment in the rack to determine the total power requirement of the supply circuit.
- *(For sliding drawers.)* Do not pull out or install any drawer or feature if the rack stabilizer brackets are not attached to the rack. Do not pull out more than one drawer at a time. The rack might become unstable if you pull out more than one drawer at a time.
- *(For fixed drawers.)* This drawer is a fixed drawer and must not be moved for servicing unless specified by the manufacturer. Attempting to move the drawer partially or completely out of the rack might cause the rack to become unstable or cause the drawer to fall out of the rack.

(R001)

To place a rack-mounted system or expansion unit into the service position, follow these steps:

1. If necessary, open the front rack door.
2. Remove the two screws **(A)** that secure the system or expansion unit **(B)** to the rack as shown in the following figure.

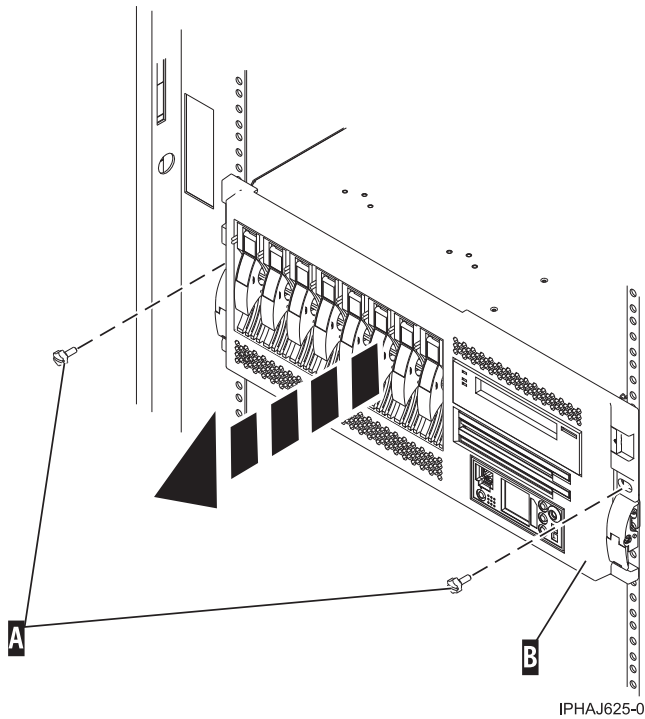

Figure 107. Removing the screws from the system and rack

3. Release the rack latches (A) on both the left and right sides as shown in the following figure.

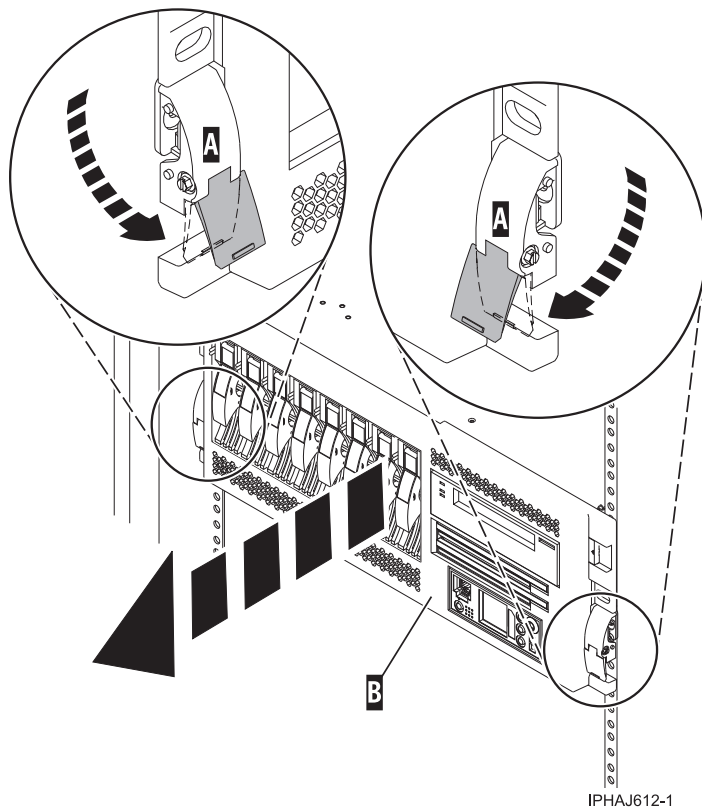

Figure 108. Releasing the rack latches

4. Read the following note, and then slowly pull the system or expansion unit out from the rack until the rails are fully extended and locked.

Remember:

- If the procedure you are performing requires you to unplug cables from the back of the system or expansion unit, do so before you pull the unit out from the rack.
- Ensure that the cables at the rear of the system or expansion unit do not catch or bind as you pull the unit out from the rack.
- Ensure the rails are fully extended. When the rails are fully extended, the rail safety latches lock into place. This action prevents the system or expansion unit from being pulled out too far.

Placing the rack-mounted system or expansion unit in the operating position

Use this procedure to place the rack-mounted system or expansion unit in the operating position to make the unit available for use.

Tip: Some of the figures in these procedures might not look exactly like the system or expansion unit that you have. However, the steps to perform the task are the same.

To place the rack-mounted system or expansion unit into the operating position, follow these steps:

1. Simultaneously release the blue rail safety latches (A), located near the front of each rail, and push the system or expansion unit into the rack as shown in the following figure.

Note: Ensure that the cables at the rear of the system or expansion unit do not catch or bind as you push the unit back into the rack.

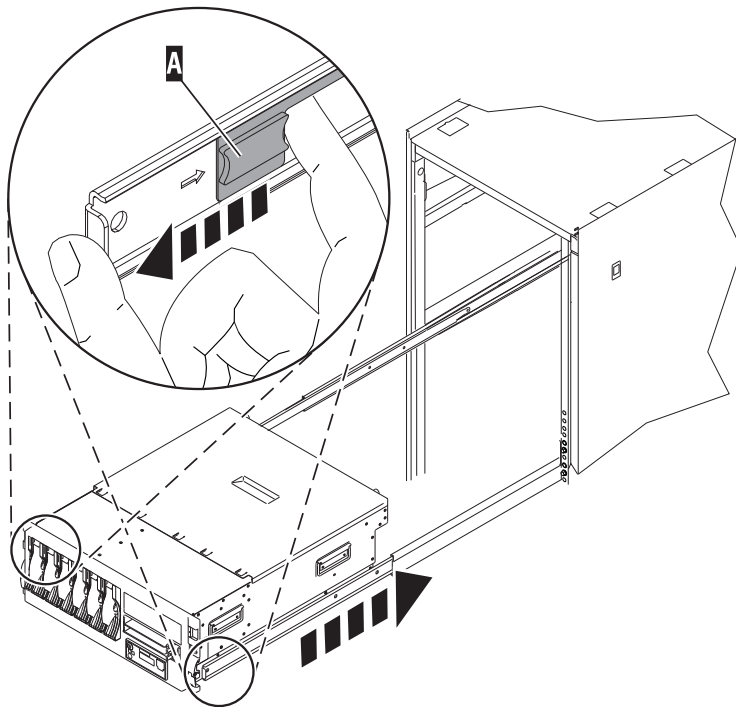

IPHBF509-1

Figure 109. Releasing the rail safety latches

2. Replace and tighten the two screws (C) that secure the system or expansion unit (A) to the rack as shown in the following figure.

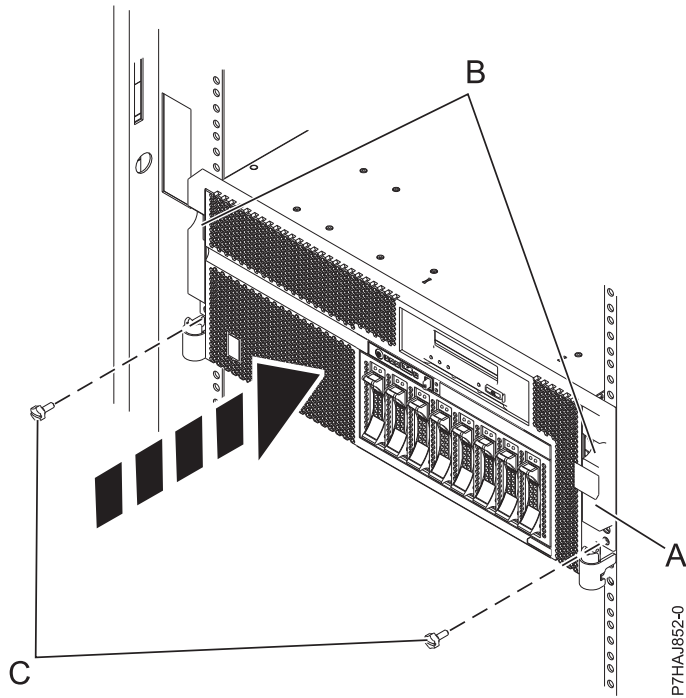

Figure 110. Pushing the system into the rack and attaching the screws

3. Close the front rack door.

Placing a 8233-E8B or 8236-E8C in the service position

Use this procedure to perform service or gain access to internal components by placing the rack-mounted system or expansion unit in the service position.

Note: Some of the figures in these procedures might not look exactly like the system or expansion unit that you have. However, the steps to perform the task are the same.

DANGER

When working on or around the system, observe the following precautions:

Electrical voltage and current from power, telephone, and communication cables are hazardous. To avoid a shock hazard:

- Connect power to this unit only with the IBM provided power cord. Do not use the IBM provided power cord for any other product.
- Do not open or service any power supply assembly.
- Do not connect or disconnect any cables or perform installation, maintenance, or reconfiguration of this product during an electrical storm.
- The product might be equipped with multiple power cords. To remove all hazardous voltages, disconnect all power cords.
- Connect all power cords to a properly wired and grounded electrical outlet. Ensure that the outlet supplies proper voltage and phase rotation according to the system rating plate.
- Connect any equipment that will be attached to this product to properly wired outlets.
- When possible, use one hand only to connect or disconnect signal cables.
- Never turn on any equipment when there is evidence of fire, water, or structural damage.
- Disconnect the attached power cords, telecommunications systems, networks, and modems before you open the device covers, unless instructed otherwise in the installation and configuration procedures.
- Connect and disconnect cables as described in the following procedures when installing, moving, or opening covers on this product or attached devices.

To Disconnect:

1. Turn off everything (unless instructed otherwise).
2. Remove the power cords from the outlets.
3. Remove the signal cables from the connectors.
4. Remove all cables from the devices

To Connect:

1. Turn off everything (unless instructed otherwise).
2. Attach all cables to the devices.
3. Attach the signal cables to the connectors.
4. Attach the power cords to the outlets.
5. Turn on the devices.

(D005)

DANGER

Observe the following precautions when working on or around your IT rack system:

- Heavy equipment—personal injury or equipment damage might result if mishandled.
- Always lower the leveling pads on the rack cabinet.
- Always install stabilizer brackets on the rack cabinet.
- To avoid hazardous conditions due to uneven mechanical loading, always install the heaviest devices in the bottom of the rack cabinet. Always install servers and optional devices starting from the bottom of the rack cabinet.
- Rack-mounted devices are not to be used as shelves or work spaces. Do not place objects on top of rack-mounted devices.



- Each rack cabinet might have more than one power cord. Be sure to disconnect all power cords in the rack cabinet when directed to disconnect power during servicing.
- Connect all devices installed in a rack cabinet to power devices installed in the same rack cabinet. Do not plug a power cord from a device installed in one rack cabinet into a power device installed in a different rack cabinet.
- An electrical outlet that is not correctly wired could place hazardous voltage on the metal parts of the system or the devices that attach to the system. It is the responsibility of the customer to ensure that the outlet is correctly wired and grounded to prevent an electrical shock.

CAUTION

- Do not install a unit in a rack where the internal rack ambient temperatures will exceed the manufacturer's recommended ambient temperature for all your rack-mounted devices.
- Do not install a unit in a rack where the air flow is compromised. Ensure that air flow is not blocked or reduced on any side, front, or back of a unit used for air flow through the unit.
- Consideration should be given to the connection of the equipment to the supply circuit so that overloading of the circuits does not compromise the supply wiring or overcurrent protection. To provide the correct power connection to a rack, refer to the rating labels located on the equipment in the rack to determine the total power requirement of the supply circuit.
- *(For sliding drawers.)* Do not pull out or install any drawer or feature if the rack stabilizer brackets are not attached to the rack. Do not pull out more than one drawer at a time. The rack might become unstable if you pull out more than one drawer at a time.
- *(For fixed drawers.)* This drawer is a fixed drawer and must not be moved for servicing unless specified by the manufacturer. Attempting to move the drawer partially or completely out of the rack might cause the rack to become unstable or cause the drawer to fall out of the rack.

(R001)

To place the rack-mounted system or expansion unit into the service position, follow these steps:

1. If necessary, open the front rack door.
2. Remove the two screws **(A)** that secure the system unit to the rack as shown in the following figure.
3. Release the rack latches **(B)** on both the left and right sides as shown in the following figure.

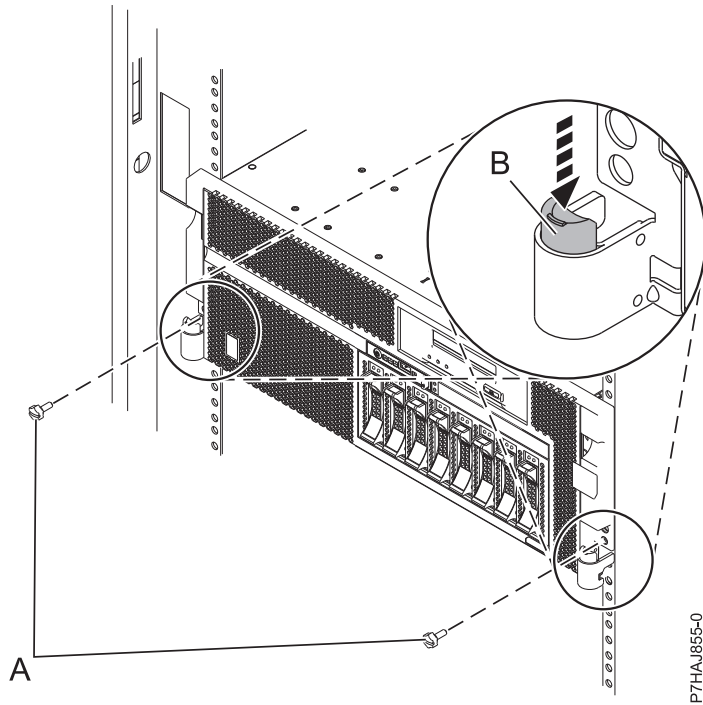

Figure 111. Releasing the rack latches

4. If required, unplug the cables from the back of the system or expansion unit before you pull the unit out from the rack. Ensure that the cables at the rear of the system or expansion unit do not catch or bind as you pull the unit out from the rack.
5. Slowly pull the system or expansion unit out from the rack until the rails are fully extended and locked. Ensure that the rails are fully extended. When the rails are fully extended, the rail safety latches lock into place. This action prevents the system or expansion unit from being pulled out too far.

Placing the 8233-E8B or 8236-E8C in the operating position

Use this procedure to place the system or expansion unit in the operating position to make the unit available for use.

To place the system into the operating position follow these steps:

Tip: Some of the figures in these procedures might not look exactly like the system or expansion unit that you have. However, the steps to perform the task are the same.

1. Simultaneously release the blue rail safety latches (**B**), located near the front of each rail, and push the system or expansion unit into the rack as shown in the following figure.

Note: Ensure that the cables at the rear of the system or expansion unit do not catch or bind as you push the unit back into the rack.

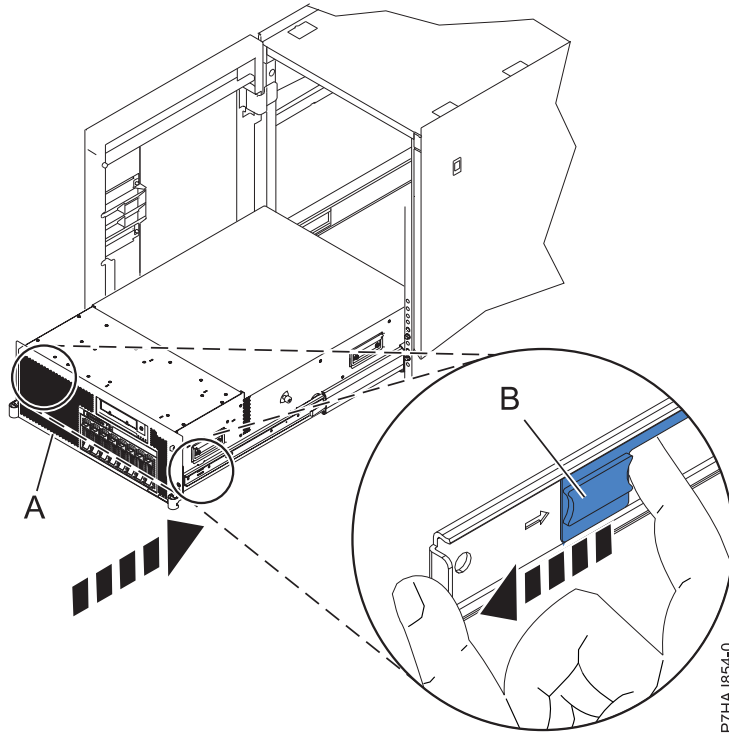

Figure 112. Releasing the rail safety latches

2. Replace and tighten the two thumbscrews (C) that secure the system or expansion unit (A) to the rack as shown in the following figure.

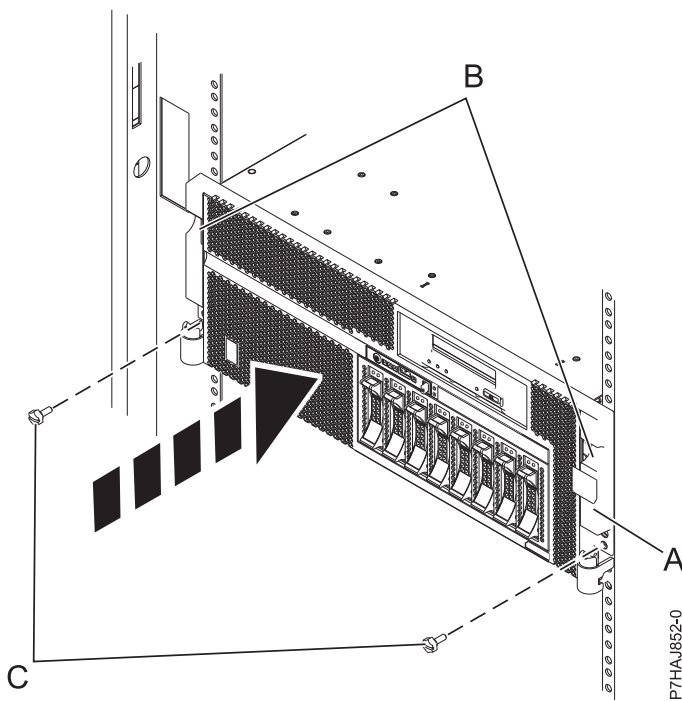

Figure 113. Replacing the thumbscrews

3. Close the front rack door.

Appendix. Notices

This information was developed for products and services offered in the U.S.A.

The manufacturer may not offer the products, services, or features discussed in this document in other countries. Consult the manufacturer's representative for information on the products and services currently available in your area. Any reference to the manufacturer's product, program, or service is not intended to state or imply that only that product, program, or service may be used. Any functionally equivalent product, program, or service that does not infringe any intellectual property right of the manufacturer may be used instead. However, it is the user's responsibility to evaluate and verify the operation of any product, program, or service.

The manufacturer may have patents or pending patent applications covering subject matter described in this document. The furnishing of this document does not grant you any license to these patents. You can send license inquiries, in writing, to the manufacturer.

The following paragraph does not apply to the United Kingdom or any other country where such provisions are inconsistent with local law: THIS INFORMATION IS PROVIDED "AS IS" WITHOUT WARRANTY OF ANY KIND, EITHER EXPRESS OR IMPLIED, INCLUDING, BUT NOT LIMITED TO, THE IMPLIED WARRANTIES OF NON-INFRINGEMENT, MERCHANTABILITY OR FITNESS FOR A PARTICULAR PURPOSE. Some states do not allow disclaimer of express or implied warranties in certain transactions, therefore, this statement may not apply to you.

This information could include technical inaccuracies or typographical errors. Changes are periodically made to the information herein; these changes will be incorporated in new editions of the publication. The manufacturer may make improvements and/or changes in the product(s) and/or the program(s) described in this publication at any time without notice.

Any references in this information to Web sites not owned by the manufacturer are provided for convenience only and do not in any manner serve as an endorsement of those Web sites. The materials at those Web sites are not part of the materials for this product and use of those Web sites is at your own risk.

The manufacturer may use or distribute any of the information you supply in any way it believes appropriate without incurring any obligation to you.

Any performance data contained herein was determined in a controlled environment. Therefore, the results obtained in other operating environments may vary significantly. Some measurements may have been made on development-level systems and there is no guarantee that these measurements will be the same on generally available systems. Furthermore, some measurements may have been estimated through extrapolation. Actual results may vary. Users of this document should verify the applicable data for their specific environment.

Information concerning products not produced by this manufacturer was obtained from the suppliers of those products, their published announcements or other publicly available sources. This manufacturer has not tested those products and cannot confirm the accuracy of performance, compatibility or any other claims related to products not produced by this manufacturer. Questions on the capabilities of products not produced by this manufacturer should be addressed to the suppliers of those products.

All statements regarding the manufacturer's future direction or intent are subject to change or withdrawal without notice, and represent goals and objectives only.

The manufacturer's prices shown are the manufacturer's suggested retail prices, are current and are subject to change without notice. Dealer prices may vary.

This information is for planning purposes only. The information herein is subject to change before the products described become available.

This information contains examples of data and reports used in daily business operations. To illustrate them as completely as possible, the examples include the names of individuals, companies, brands, and products. All of these names are fictitious and any similarity to the names and addresses used by an actual business enterprise is entirely coincidental.

If you are viewing this information in softcopy, the photographs and color illustrations may not appear.

The drawings and specifications contained herein shall not be reproduced in whole or in part without the written permission of the manufacturer.

The manufacturer has prepared this information for use with the specific machines indicated. The manufacturer makes no representations that it is suitable for any other purpose.

The manufacturer's computer systems contain mechanisms designed to reduce the possibility of undetected data corruption or loss. This risk, however, cannot be eliminated. Users who experience unplanned outages, system failures, power fluctuations or outages, or component failures must verify the accuracy of operations performed and data saved or transmitted by the system at or near the time of the outage or failure. In addition, users must establish procedures to ensure that there is independent data verification before relying on such data in sensitive or critical operations. Users should periodically check the manufacturer's support websites for updated information and fixes applicable to the system and related software.

Trademarks

IBM, the IBM logo, and ibm.com are trademarks or registered trademarks of International Business Machines Corp., registered in many jurisdictions worldwide. Other product and service names might be trademarks of IBM or other companies. A current list of IBM trademarks is available on the Web at Copyright and trademark information at www.ibm.com/legal/copytrade.shtml.

Microsoft and Windows are trademarks of Microsoft Corporation in the United States, other countries, or both.

Other company, product, or service names may be trademarks or service marks of others.

Electronic emission notices

Class A Notices

The following Class A statements apply to the IBM servers that contain the POWER7 processor and its features unless designated as electromagnetic compatibility (EMC) Class B in the feature information.

Federal Communications Commission (FCC) statement

Note: This equipment has been tested and found to comply with the limits for a Class A digital device, pursuant to Part 15 of the FCC Rules. These limits are designed to provide reasonable protection against harmful interference when the equipment is operated in a commercial environment. This equipment generates, uses, and can radiate radio frequency energy and, if not installed and used in accordance with the instruction manual, may cause harmful interference to radio communications. Operation of this equipment in a residential area is likely to cause harmful interference, in which case the user will be required to correct the interference at his own expense.

Properly shielded and grounded cables and connectors must be used in order to meet FCC emission limits. IBM is not responsible for any radio or television interference caused by using other than recommended cables and connectors or by unauthorized changes or modifications to this equipment. Unauthorized changes or modifications could void the user's authority to operate the equipment.

This device complies with Part 15 of the FCC rules. Operation is subject to the following two conditions: (1) this device may not cause harmful interference, and (2) this device must accept any interference received, including interference that may cause undesired operation.

Industry Canada Compliance Statement

This Class A digital apparatus complies with Canadian ICES-003.

Avis de conformité à la réglementation d'Industrie Canada

Cet appareil numérique de la classe A est conforme à la norme NMB-003 du Canada.

European Community Compliance Statement

This product is in conformity with the protection requirements of EU Council Directive 2004/108/EC on the approximation of the laws of the Member States relating to electromagnetic compatibility. IBM cannot accept responsibility for any failure to satisfy the protection requirements resulting from a non-recommended modification of the product, including the fitting of non-IBM option cards.

This product has been tested and found to comply with the limits for Class A Information Technology Equipment according to European Standard EN 55022. The limits for Class A equipment were derived for commercial and industrial environments to provide reasonable protection against interference with licensed communication equipment.

European Community contact:
IBM Deutschland GmbH
Technical Regulations, Department M456
IBM-Allee 1, 71139 Ehningen, Germany
Tele: +49 7032 15-2937
e-mail: tjahn@de.ibm.com

Warning: This is a Class A product. In a domestic environment, this product may cause radio interference, in which case the user may be required to take adequate measures.

VCCI Statement - Japan

この装置は、クラスA 情報技術装置です。この装置を家庭環境で使用すると電波妨害を引き起こすことがあります。この場合には使用者が適切な対策を講ずるよう要求されることがあります。

VCCI-A

The following is a summary of the VCCI Japanese statement in the box above:

This is a Class A product based on the standard of the VCCI Council. If this equipment is used in a domestic environment, radio interference may occur, in which case, the user may be required to take corrective actions.

**Japanese Electronics and Information Technology Industries Association (JEITA)
Confirmed Harmonics Guideline (products less than or equal to 20 A per phase)**

高調波ガイドライン適合品

**Japanese Electronics and Information Technology Industries Association (JEITA)
Confirmed Harmonics Guideline with Modifications (products greater than 20 A per phase)**

高調波ガイドライン準用品

Electromagnetic Interference (EMI) Statement - People's Republic of China

声 明

此为 A 级产品,在生活环境中,
该产品可能会造成无线电干扰。
在这种情况下,可能需要用户对其
干扰采取切实可行的措施。

Declaration: This is a Class A product. In a domestic environment this product may cause radio interference in which case the user may need to perform practical action.

Electromagnetic Interference (EMI) Statement - Taiwan

警告使用者：

這是甲類的資訊產品，在
居住的環境中使用時，可
能會造成射頻干擾，在這
種情況下，使用者會被要
求採取某些適當的對策。

The following is a summary of the EMI Taiwan statement above.

Warning: This is a Class A product. In a domestic environment this product may cause radio interference in which case the user will be required to take adequate measures.

IBM Taiwan Contact Information:

台灣IBM 產品服務聯絡方式：
台灣國際商業機器股份有限公司
台北市松仁路7號3樓
電話：0800-016-888

Electromagnetic Interference (EMI) Statement - Korea

이 기기는 업무용으로 전자파적합등록을 한 기기이오니 판매자 또는 사용자는 이점을 주의하시기 바라며, 만약 잘못 판매 또는 구입하였을 때에는 가정용으로 교환하시기 바랍니다.

Please note that this equipment has obtained EMC registration for commercial use. In the event that it has been mistakenly sold or purchased, please exchange it for equipment certified for home use.

Germany Compliance Statement

Deutschsprachiger EU Hinweis: Hinweis für Geräte der Klasse A EU-Richtlinie zur Elektromagnetischen Verträglichkeit

Dieses Produkt entspricht den Schutzanforderungen der EU-Richtlinie 2004/108/EG zur Angleichung der Rechtsvorschriften über die elektromagnetische Verträglichkeit in den EU-Mitgliedsstaaten und hält die Grenzwerte der EN 55022 Klasse A ein.

Um dieses sicherzustellen, sind die Geräte wie in den Handbüchern beschrieben zu installieren und zu betreiben. Des Weiteren dürfen auch nur von der IBM empfohlene Kabel angeschlossen werden. IBM übernimmt keine Verantwortung für die Einhaltung der Schutzanforderungen, wenn das Produkt ohne Zustimmung von IBM verändert bzw. wenn Erweiterungskomponenten von Fremdherstellern ohne Empfehlung von IBM gesteckt/eingebaut werden.

EN 55022 Klasse A Geräte müssen mit folgendem Warnhinweis versehen werden:

"Warnung: Dieses ist eine Einrichtung der Klasse A. Diese Einrichtung kann im Wohnbereich Funk-Störungen verursachen; in diesem Fall kann vom Betreiber verlangt werden, angemessene Maßnahmen zu ergreifen und dafür aufzukommen."

Deutschland: Einhaltung des Gesetzes über die elektromagnetische Verträglichkeit von Geräten

Dieses Produkt entspricht dem "Gesetz über die elektromagnetische Verträglichkeit von Geräten (EMVG)". Dies ist die Umsetzung der EU-Richtlinie 2004/108/EG in der Bundesrepublik Deutschland.

Zulassungsbescheinigung laut dem Deutschen Gesetz über die elektromagnetische Verträglichkeit von Geräten (EMVG) (bzw. der EMC EG Richtlinie 2004/108/EG) für Geräte der Klasse A

Dieses Gerät ist berechtigt, in Übereinstimmung mit dem Deutschen EMVG das EG-Konformitätszeichen - CE - zu führen.

Verantwortlich für die Einhaltung der EMV Vorschriften ist der Hersteller:
International Business Machines Corp.

New Orchard Road
Armonk, New York 10504
Tel: 914-499-1900

Der verantwortliche Ansprechpartner des Herstellers in der EU ist:
IBM Deutschland GmbH
Technical Regulations, Abteilung M456
IBM-Allee 1, 71139 Ehningen, Germany
Tel: +49 7032 15-2937
e-mail: tjahn@de.ibm.com

Generelle Informationen:

Das Gerät erfüllt die Schutzanforderungen nach EN 55024 und EN 55022 Klasse A.

Electromagnetic Interference (EMI) Statement - Russia

**ВНИМАНИЕ! Настоящее изделие относится к классу А.
В жилых помещениях оно может создавать
радиопомехи, для снижения которых необходимы
дополнительные меры**

Terms and conditions

Permissions for the use of these publications is granted subject to the following terms and conditions.

Personal Use: You may reproduce these publications for your personal, noncommercial use provided that all proprietary notices are preserved. You may not distribute, display or make derivative works of these publications, or any portion thereof, without the express consent of the manufacturer.

Commercial Use: You may reproduce, distribute and display these publications solely within your enterprise provided that all proprietary notices are preserved. You may not make derivative works of these publications, or reproduce, distribute or display these publications or any portion thereof outside your enterprise, without the express consent of the manufacturer.

Except as expressly granted in this permission, no other permissions, licenses or rights are granted, either express or implied, to the publications or any information, data, software or other intellectual property contained therein.

The manufacturer reserves the right to withdraw the permissions granted herein whenever, in its discretion, the use of the publications is detrimental to its interest or, as determined by the manufacturer, the above instructions are not being properly followed.

You may not download, export or re-export this information except in full compliance with all applicable laws and regulations, including all United States export laws and regulations.

THE MANUFACTURER MAKES NO GUARANTEE ABOUT THE CONTENT OF THESE PUBLICATIONS. THESE PUBLICATIONS ARE PROVIDED "AS-IS" AND WITHOUT WARRANTY OF ANY KIND, EITHER EXPRESSED OR IMPLIED, INCLUDING BUT NOT LIMITED TO IMPLIED WARRANTIES OF MERCHANTABILITY, NON-INFRINGEMENT, AND FITNESS FOR A PARTICULAR PURPOSE.