

5786, 5787 and 7031
models D24 and T24
removal and replacement
procedures



ESCALA Power7

5786, 5787 and 7031 models D24 and T24 removal and replacement procedures

This publication concerns the following models:

- Bull Escala E5-700 (Power 750 / 8233-E8B)
- Bull Escala M6-700 (Power 770 / 9117-MMB)
- Bull Escala M7-700 (Power 780 / 9179-MHB)
- Bull Escala E1-700 (Power 710 / 8231-E2B)
- Bull Escala E2-700 / E2-700T (Power 720 / 8202-E4B)
- Bull Escala E3-700 (Power 730 / 8231-E2B)
- Bull Escala E4-700 / E4-700T (Power 740 / 8205-E6B)

References to Power 755 / 8236-E8C models are irrelevant.

Hardware

May 2011

BULL CEDOC
357 AVENUE PATTON
B.P.20845
49008 ANGERS CEDEX 01
FRANCE

REFERENCE
86 A1 57FF 03

The following copyright notice protects this book under Copyright laws which prohibit such actions as, but not limited to, copying, distributing, modifying, and making derivative works.

Copyright © Bull SAS 2007-2011

Printed in France

Suggestions and criticisms concerning the form, content, and presentation of this book are invited. A form is provided at the end of this book for this purpose.

To order additional copies of this book or other Bull Technical Publications, you are invited to use the Ordering Form also provided at the end of this book.

Trademarks and Acknowledgements

We acknowledge the right of proprietors of trademarks mentioned in this book.

The information in this document is subject to change without notice. Bull will not be liable for errors contained herein, or for incidental or consequential damages in connection with the use of this material.

Contents

Safety notices	v
5786, 5787, 7031-D24, and 7031-T24 removal and replacement procedures	1
Reference information	3
Disk drive	8
Replacing the disk drive by using IBM i.	16
Deactivating a disk drive by using AIX	16
Adding a disk drive as a resource by using AIX	17
Deactivating a disk drive by using Linux	18
Adding a disk drive as a resource by using Linux	19
Rebuild data on a replacement disk drive using Linux	19
Fan	20
Power supply	21
SCSI repeater card	23
Chassis assembly (chassis, enclosure backplane, and VPD card)	25
Problem determination procedures	27
Disk drive module power-on self-tests	27
SCSI card power-on self-tests	27
Component and attention LEDs	28
Maintenance analysis procedures	33
MAP 2010: 7031-D24 or 7031-T24 START	34
MAP 2020: 7031-D24 or 7031-T24 Power.	36
MAP 2022: 7031-D24 or 7031-T24 Power-on.	38
MAP 2030: 7031-D24 or 7031-T24 power control	40
MAP 2340: 7031-D24 or 7031-T24 SCSI bus	41
MAP 2410: Repair verification	42
Notices	43
Trademarks	44
Electronic emission notices	44
Class A Notices	44
Terms and conditions	48

Safety notices

Safety notices may be printed throughout this guide:

- **DANGER** notices call attention to a situation that is potentially lethal or extremely hazardous to people.
- **CAUTION** notices call attention to a situation that is potentially hazardous to people because of some existing condition.
- **Attention** notices call attention to the possibility of damage to a program, device, system, or data.

World Trade safety information

Several countries require the safety information contained in product publications to be presented in their national languages. If this requirement applies to your country, a safety information booklet is included in the publications package shipped with the product. The booklet contains the safety information in your national language with references to the U.S. English source. Before using a U.S. English publication to install, operate, or service this product, you must first become familiar with the related safety information in the booklet. You should also refer to the booklet any time you do not clearly understand any safety information in the U.S. English publications.

German safety information

Das Produkt ist nicht für den Einsatz an Bildschirmarbeitsplätzen im Sinne § 2 der Bildschirmarbeitsverordnung geeignet.

Laser safety information

IBM® servers can use I/O cards or features that are fiber-optic based and that utilize lasers or LEDs.

Laser compliance

IBM servers may be installed inside or outside of an IT equipment rack.

DANGER

When working on or around the system, observe the following precautions:

Electrical voltage and current from power, telephone, and communication cables are hazardous. To avoid a shock hazard:

- Connect power to this unit only with the IBM provided power cord. Do not use the IBM provided power cord for any other product.
- Do not open or service any power supply assembly.
- Do not connect or disconnect any cables or perform installation, maintenance, or reconfiguration of this product during an electrical storm.
- The product might be equipped with multiple power cords. To remove all hazardous voltages, disconnect all power cords.
- Connect all power cords to a properly wired and grounded electrical outlet. Ensure that the outlet supplies proper voltage and phase rotation according to the system rating plate.
- Connect any equipment that will be attached to this product to properly wired outlets.
- When possible, use one hand only to connect or disconnect signal cables.
- Never turn on any equipment when there is evidence of fire, water, or structural damage.
- Disconnect the attached power cords, telecommunications systems, networks, and modems before you open the device covers, unless instructed otherwise in the installation and configuration procedures.
- Connect and disconnect cables as described in the following procedures when installing, moving, or opening covers on this product or attached devices.

To Disconnect:

1. Turn off everything (unless instructed otherwise).
2. Remove the power cords from the outlets.
3. Remove the signal cables from the connectors.
4. Remove all cables from the devices

To Connect:

1. Turn off everything (unless instructed otherwise).
2. Attach all cables to the devices.
3. Attach the signal cables to the connectors.
4. Attach the power cords to the outlets.
5. Turn on the devices.

(D005)

DANGER

Observe the following precautions when working on or around your IT rack system:

- Heavy equipment—personal injury or equipment damage might result if mishandled.
- Always lower the leveling pads on the rack cabinet.
- Always install stabilizer brackets on the rack cabinet.
- To avoid hazardous conditions due to uneven mechanical loading, always install the heaviest devices in the bottom of the rack cabinet. Always install servers and optional devices starting from the bottom of the rack cabinet.
- Rack-mounted devices are not to be used as shelves or work spaces. Do not place objects on top of rack-mounted devices.



- Each rack cabinet might have more than one power cord. Be sure to disconnect all power cords in the rack cabinet when directed to disconnect power during servicing.
- Connect all devices installed in a rack cabinet to power devices installed in the same rack cabinet. Do not plug a power cord from a device installed in one rack cabinet into a power device installed in a different rack cabinet.
- An electrical outlet that is not correctly wired could place hazardous voltage on the metal parts of the system or the devices that attach to the system. It is the responsibility of the customer to ensure that the outlet is correctly wired and grounded to prevent an electrical shock.

CAUTION

- Do not install a unit in a rack where the internal rack ambient temperatures will exceed the manufacturer's recommended ambient temperature for all your rack-mounted devices.
- Do not install a unit in a rack where the air flow is compromised. Ensure that air flow is not blocked or reduced on any side, front, or back of a unit used for air flow through the unit.
- Consideration should be given to the connection of the equipment to the supply circuit so that overloading of the circuits does not compromise the supply wiring or overcurrent protection. To provide the correct power connection to a rack, refer to the rating labels located on the equipment in the rack to determine the total power requirement of the supply circuit.
- *(For sliding drawers.)* Do not pull out or install any drawer or feature if the rack stabilizer brackets are not attached to the rack. Do not pull out more than one drawer at a time. The rack might become unstable if you pull out more than one drawer at a time.
- *(For fixed drawers.)* This drawer is a fixed drawer and must not be moved for servicing unless specified by the manufacturer. Attempting to move the drawer partially or completely out of the rack might cause the rack to become unstable or cause the drawer to fall out of the rack.

(R001)

CAUTION:

Removing components from the upper positions in the rack cabinet improves rack stability during relocation. Follow these general guidelines whenever you relocate a populated rack cabinet within a room or building:

- Reduce the weight of the rack cabinet by removing equipment starting at the top of the rack cabinet. When possible, restore the rack cabinet to the configuration of the rack cabinet as you received it. If this configuration is not known, you must observe the following precautions:
 - Remove all devices in the 32U position and above.
 - Ensure that the heaviest devices are installed in the bottom of the rack cabinet.
 - Ensure that there are no empty U-levels between devices installed in the rack cabinet below the 32U level.
- If the rack cabinet you are relocating is part of a suite of rack cabinets, detach the rack cabinet from the suite.
- Inspect the route that you plan to take to eliminate potential hazards.
- Verify that the route that you choose can support the weight of the loaded rack cabinet. Refer to the documentation that comes with your rack cabinet for the weight of a loaded rack cabinet.
- Verify that all door openings are at least 760 x 230 mm (30 x 80 in.).
- Ensure that all devices, shelves, drawers, doors, and cables are secure.
- Ensure that the four leveling pads are raised to their highest position.
- Ensure that there is no stabilizer bracket installed on the rack cabinet during movement.
- Do not use a ramp inclined at more than 10 degrees.
- When the rack cabinet is in the new location, complete the following steps:
 - Lower the four leveling pads.
 - Install stabilizer brackets on the rack cabinet.
 - If you removed any devices from the rack cabinet, repopulate the rack cabinet from the lowest position to the highest position.
- If a long-distance relocation is required, restore the rack cabinet to the configuration of the rack cabinet as you received it. Pack the rack cabinet in the original packaging material, or equivalent. Also lower the leveling pads to raise the casters off of the pallet and bolt the rack cabinet to the pallet.

(R002)

(L001)



(L002)



(L003)

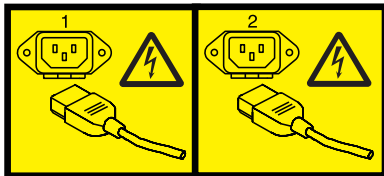

or



All lasers are certified in the U.S. to conform to the requirements of DHHS 21 CFR Subchapter J for class 1 laser products. Outside the U.S., they are certified to be in compliance with IEC 60825 as a class 1 laser product. Consult the label on each part for laser certification numbers and approval information.

CAUTION:

This product might contain one or more of the following devices: CD-ROM drive, DVD-ROM drive, DVD-RAM drive, or laser module, which are Class 1 laser products. Note the following information:

- Do not remove the covers. Removing the covers of the laser product could result in exposure to hazardous laser radiation. There are no serviceable parts inside the device.
- Use of the controls or adjustments or performance of procedures other than those specified herein might result in hazardous radiation exposure.

(C026)

CAUTION:

Data processing environments can contain equipment transmitting on system links with laser modules that operate at greater than Class 1 power levels. For this reason, never look into the end of an optical fiber cable or open receptacle. (C027)

CAUTION:

This product contains a Class 1M laser. Do not view directly with optical instruments. (C028)

CAUTION:

Some laser products contain an embedded Class 3A or Class 3B laser diode. Note the following information: laser radiation when open. Do not stare into the beam, do not view directly with optical instruments, and avoid direct exposure to the beam. (C030)

Power and cabling information for NEBS (Network Equipment-Building System) GR-1089-CORE

The following comments apply to the IBM servers that have been designated as conforming to NEBS (Network Equipment-Building System) GR-1089-CORE:

The equipment is suitable for installation in the following:

- Network telecommunications facilities
- Locations where the NEC (National Electrical Code) applies

The intrabuilding ports of this equipment are suitable for connection to intrabuilding or unexposed wiring or cabling only. The intrabuilding ports of this equipment *must not* be metallically connected to the interfaces that connect to the OSP (outside plant) or its wiring. These interfaces are designed for use as intrabuilding interfaces only (Type 2 or Type 4 ports as described in GR-1089-CORE) and require isolation from the exposed OSP cabling. The addition of primary protectors is not sufficient protection to connect these interfaces metallically to OSP wiring.

Note: All Ethernet cables must be shielded and grounded at both ends.

The ac-powered system does not require the use of an external surge protection device (SPD).

The dc-powered system employs an isolated DC return (DC-I) design. The DC battery return terminal *shall not* be connected to the chassis or frame ground.

5786, 5787, 7031-D24, and 7031-T24 removal and replacement procedures

Use the removal and replacement procedures when exchanging, maintaining or repairing your I/O enclosure parts.

Before you begin a replacement procedure, perform these tasks:

- If you are performing a replacement procedure that might put your data at risk, ensure, if possible, that you have a current backup of your system or logical partition (including operating systems, licensed programs, and data). For information about backing up your system or logical partition, go to <http://www.ibm.com/systems/i/infocenter>
- Review the installation or replacement procedure for the feature or part.
- Note the significance of color on your system. Blue or terra-cotta on a part of the hardware indicates a touch point where you can grip the hardware to remove it from or install it in the system, open or close a latch, and so on. terra-cotta might also indicate that the part can be removed and replaced with the system or logical partition power on.
- Ensure that you have access to a medium, flat-blade screwdriver.
- If parts are incorrect, missing, or visibly damaged, contact the provider of your parts, or your next level of support.

DANGER

When working on or around the system, observe the following precautions:

Electrical voltage and current from power, telephone, and communication cables are hazardous. To avoid a shock hazard:

- Connect power to this unit only with the IBM provided power cord. Do not use the IBM provided power cord for any other product.
- Do not open or service any power supply assembly.
- Do not connect or disconnect any cables or perform installation, maintenance, or reconfiguration of this product during an electrical storm.
- The product might be equipped with multiple power cords. To remove all hazardous voltages, disconnect all power cords.
- Connect all power cords to a properly wired and grounded electrical outlet. Ensure that the outlet supplies proper voltage and phase rotation according to the system rating plate.
- Connect any equipment that will be attached to this product to properly wired outlets.
- When possible, use one hand only to connect or disconnect signal cables.
- Never turn on any equipment when there is evidence of fire, water, or structural damage.
- Disconnect the attached power cords, telecommunications systems, networks, and modems before you open the device covers, unless instructed otherwise in the installation and configuration procedures.
- Connect and disconnect cables as described in the following procedures when installing, moving, or opening covers on this product or attached devices.

To Disconnect:

1. Turn off everything (unless instructed otherwise).
2. Remove the power cords from the outlets.
3. Remove the signal cables from the connectors.
4. Remove all cables from the devices

To Connect:

1. Turn off everything (unless instructed otherwise).
2. Attach all cables to the devices.
3. Attach the signal cables to the connectors.
4. Attach the power cords to the outlets.
5. Turn on the devices.

(D005)

Attention:

Failure to follow the step-by-step sequence for FRU removal or installation might result in FRU or system damage.

Use the following precautions whenever you handle electronic components or cables.

- The electrostatic discharge (ESD) kit and the ESD wrist strap must be used when handling logic cards, SCMs, MCMs, electronic boards, and disk drives.
- Keep all electronic components in the shipping container or envelope until you are ready to install them.
- If you remove, then reinstall an electronic component, temporarily place the component on an ESD pad or blanket.

Reference information

Provides reference information such as size and capacity of power supplies, cooling fans, and Ultra 320 small computer system interface (SCSI) connections for the 5786, 5787, 7031-D24, and 7031-T24 I/O enclosures.

I/O enclosure overview

The following System i[®] models are available:

- 5786 - Rack-installable drawer model
- 5787 - Deskside (Tower) model

The following System p[®] models are available:

- 7031-D24 - Rack-installable drawer model
- 7031-T24 - Deskside (Tower) model

Note: The remainder of this topic collection refers to the 5786, 5787, 7031-D24, and 7031-T24 as either "your I/O enclosure" or "the I/O enclosure."

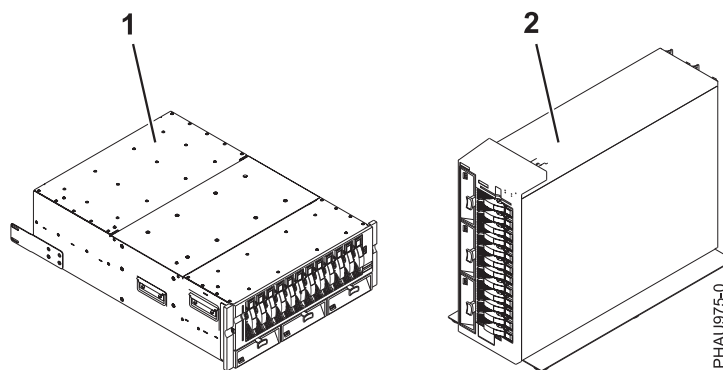

Index number	Description
1	5786, 7031-D24 disk I/O enclosure
2	5787, 7031-T24 disk I/O enclosure

Note: Only 12 disk drives are allowed per SCSI. The front and rear disk drives cannot be on the same SCSI.

The disk drives are organized in four independent SCSI groups of six drives in each group. With the use of up to four SCSI repeater cards, you can use either of the following host SCSI bus connection options:

- A single initiator to each SCSI group
- A high-availability dual initiator feature that allows the connection of two adapters to a SCSI group

The high-availability SCSI connection feature can be used on any or all of the drive groups in the enclosure and together with other drive groups in the enclosure, using the standard connection option. Power is provided through ac power cords. Either model can be set up to use 100-127 V ac or 200-240 V ac.

Power and fault indicators

Light emitting diodes (LEDs) are located either on or near the major serviceable components in the enclosure. When it is lit, the LEDs emit either a green or amber light.

When it is lit, a green LED indicates either of the following:

- Electric power is present.
- Activity is occurring on a link. (The enclosure could be sending or receiving information.)

When it is lit, an amber LED indicates a fault or identify condition. If the enclosure or one of the components on your system has an amber LED turned on solid (not blinking) or blinking, identify the problem and take the appropriate action to restore the component to a normal operating condition.

For more information about specific LEDs found on or near the major serviceable components in your enclosure, see "Component and attention LEDs" on page 28.

Storage

Storage is accomplished through the use of standard size SCSI U320 (LVD) disk drives. The disk drives must be housed in a U3 disk carrier with a standard interposer card (part number 24L0787). Light pipes located on the disk carriers transmit light from LEDs located on the disk-drive backplane. The LEDs are used to aid in the identification and failure diagnostics of each disk drive. For more information concerning disk-drive LEDs used by this enclosure, see "Component and attention LEDs" on page 28. The following disk drive sizes and speeds are available:

10,000 revolution per minute (RPM) disk drives	15,000 RPM disk drives
<ul style="list-style-type: none">• 73.4 GB Ultra320, height =1 inch• 146.8 GB Ultra320, height =1 inch• 300 GB Ultra320, height =1 inch	<ul style="list-style-type: none">• 36.4 GB Ultra320, height =1 inch• 73.4 GB Ultra320, height =1 inch• 146.8 GB Ultra320, height =1 inch• 300 GB Ultra320, height =1 inch
For an updated listing of supported disk drive sizes, contact your sales representative or next level of support.	

The chassis of your I/O enclosure contains 24 hot-plug disk-drive bays. Twelve of the disk-drive bays are located in the front and twelve disk-drive bays are located in the back of the enclosure. Any disk drive bay not populated with a disk drive *must* contain a "dummy carrier" to control the airflow within the enclosure. The dummy carrier does not contain light pipes or electrical connection, so enclosure services cannot determine whether it is installed.

Attention: To avoid overheating of the enclosure components, you must install dummy carriers in empty disk-drive bays.

The following illustrations show the front and back of the enclosure's disk-drive bay locations. On System i enclosures, each disk-drive bay contains a LED used to identify the bay. A specific disk-drive bay LED will be lit as you follow the steps in performing a concurrent removal or replacement procedure on that bay. The identify LED is amber colored. For more information concerning these LEDs, see "Component and attention LEDs" on page 28.

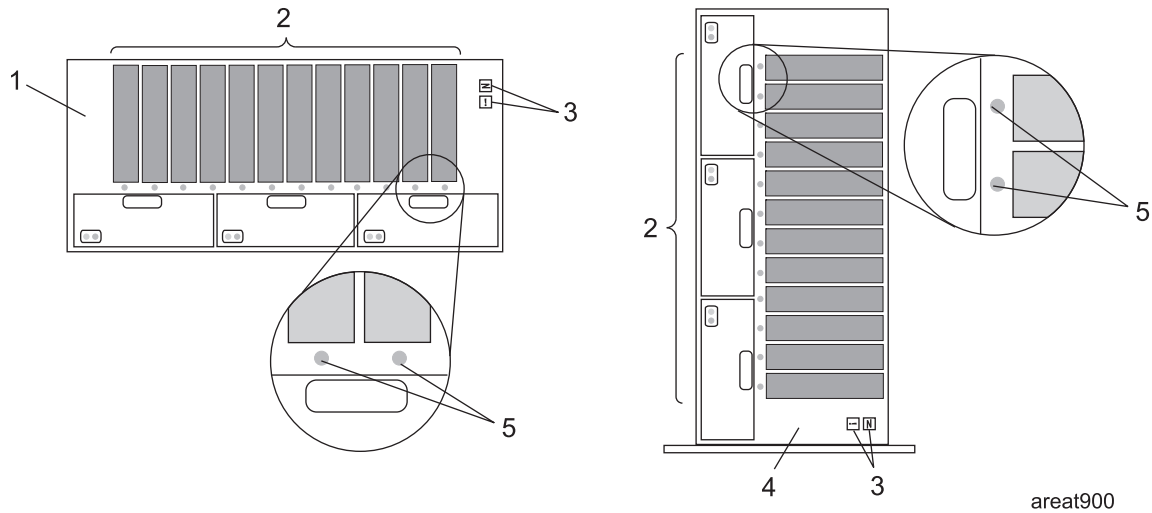

Figure 1. Front view of your I/O enclosure

Index number	Description
1	5786, 7031-D24 disk I/O enclosure (front of rack drawer configuration)
2	Shows 12 disk-bay location
3	Enclosure status panel
4	5787, 7031-T24 disk I/O enclosure (front of deskside configuration)
5	Disk drive bay identify LED locations-front (on System i models only)

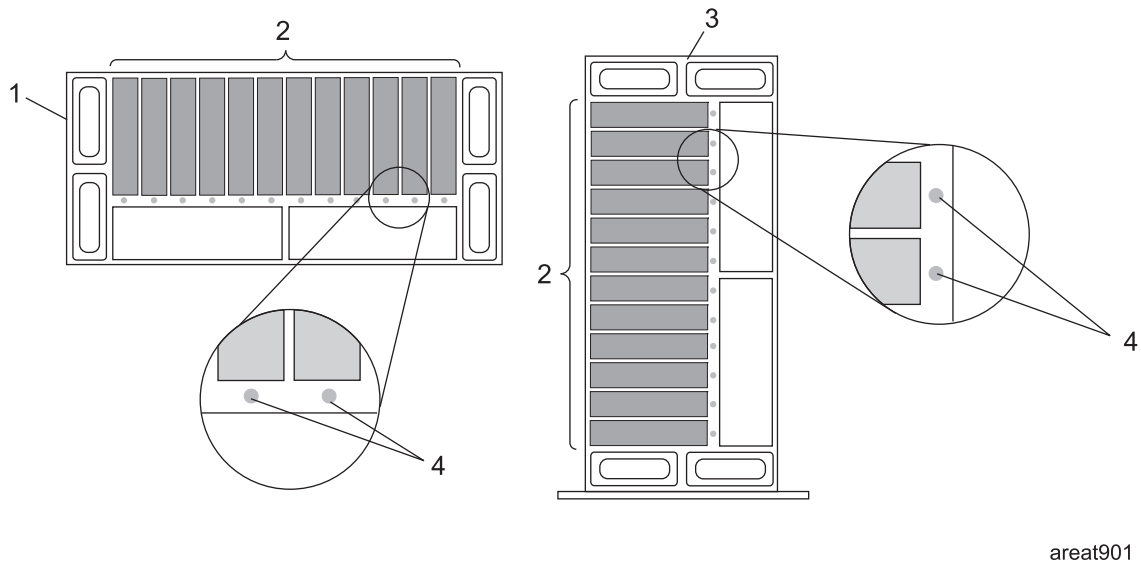

Figure 2. Back view of your I/O enclosure

Index number	Description
1	5786, 7031-D24 disk I/O enclosure (back of rack drawer configuration)
2	Shows 12 disk-bay location
3	5787, 7031-T24 disk I/O enclosure (back of deskside configuration)
4	Disk drive bay identify LED locations-back (on System i models only)

Power

The base model enclosure contains one power supply. If your system contains only a single power supply, you *must* have installed a power supply filler assembly in order to control airflow and EMC wave leakage from your enclosure. If necessary, see System parts for the power supply filler part number.

To enable redundant power supply, you can install a second power supply in the enclosure. If your enclosure contains two power supplies, either of the power supplies can provide the necessary voltages and currents, independent of each other. Having redundant power supplies enables you to remove a power supply without powering off the system. When operating correctly, each supply shares the current load when powered on. If one of the power supplies goes into a fault state, an amber LED, located on the faulted power supply, will be lit indicating a fault condition. The other operating power supply will supply enough power to the system until the faulty supply can either be powered on or replaced.

The power supply assembly has the following LEDs:

- Two green LEDs (ac power good and dc power good)
- Two amber LEDs (the far right LED indicates the power supply status)

To better understand the LEDs located on your power supply, see the table in “Component and attention LEDs” on page 28.

The following illustration identifies the location of the power supplies and the power supply LEDs.

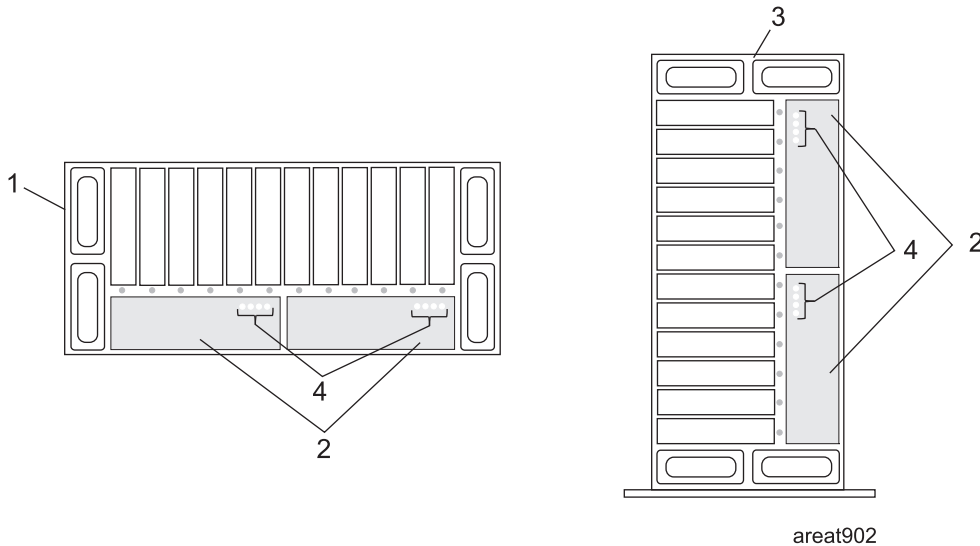

Figure 3. Back view of your I/O enclosure showing power supplies

Index number	Description
1	5786, 7031-D24 disk I/O enclosure (back of rack drawer configuration)
2	Power supply bay locations
3	5787, 7031-T24 disk I/O enclosure (back of deskside configuration)
4	Power supply power, identify/fault LED locations

Cooling

Component cooling is provided by the following methods:

- 6 Removal and replacement procedures

5786, 7031-D24

Three fans located on the front bottom of the chassis

5787, 7031-T24

Three fans located on the front-left side of the chassis

If a fan fails, the other two fans accelerate so that they cool all components. Fan speeds also increase if a power supply fails. Each fan has a green and amber LED located on the front of the unit. A solidly lit (not blinking) amber LED indicates a fault or identify condition with the fan. A solidly lit (not blinking) green LED indicates that the fan is operating correctly.

If your fan is not turning fast enough, the amber LED will be lit. The fan will require servicing.

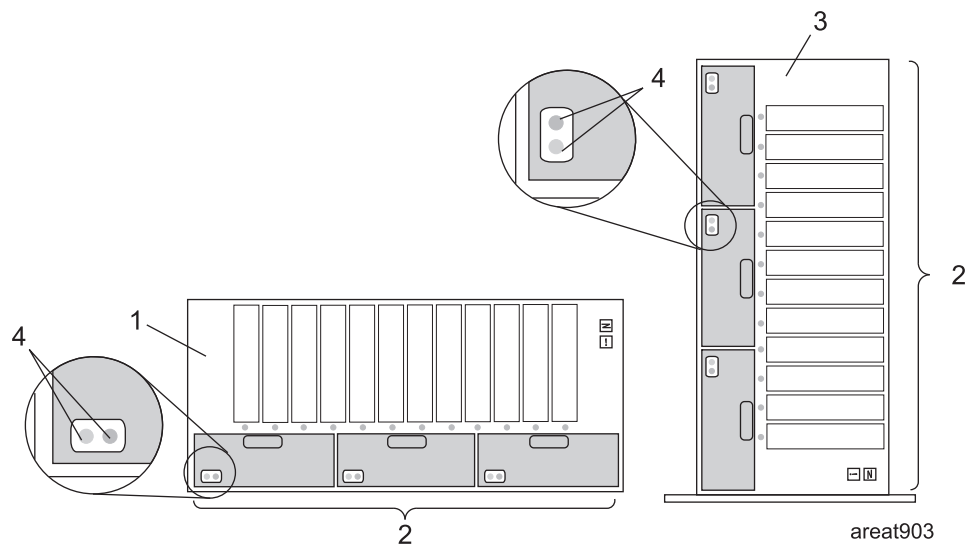

Figure 4. Cooling Fan locations on the front of your I/O enclosure

Index number	Description
1	5786, 7031-D24 disk I/O enclosure (front of rack drawer configuration)
2	Fan (blower) locations
3	5787, 7031-T24 disk I/O enclosure (front of deskside configuration)

SCSI

SCSI connections are provided by using up to four SCSI repeater cards for each I/O enclosure. The SCSI repeater cards are available in both single and dual initiator versions. Each SCSI repeater card contains a differential SCSI repeater, host terminators, system enclosure services (SES) module, SCSI drive terminators (for termination at both ends of the SCSI bus), VPD modules, and controls for both power and cooling. The SCSI repeater cards can be serviced concurrently, (with the system and I/O enclosure power on), or nonconcurrently, (with the system powered off). The repeater card provides the following functions to the I/O enclosure:

- Provide SCSI enclosure services at the SCSI address F (E and F for dual initiator version)
- Read the power supply unit vital product data (VPD) information
- Monitor the fan and power supply fault lines
- Drive the fan unit fault LEDs
- Drive the chassis fault LED
- Monitor the early power off warning (EPOW) signal from the power supplies

- Support the hot plugging of disk drives
- Control the fan speed
- Provide chassis power on signal
- Provide redrive capabilities to the SCSI host bus
- Provide termination for host and drive buses
- Detect the disk drive and the disk drive operating condition

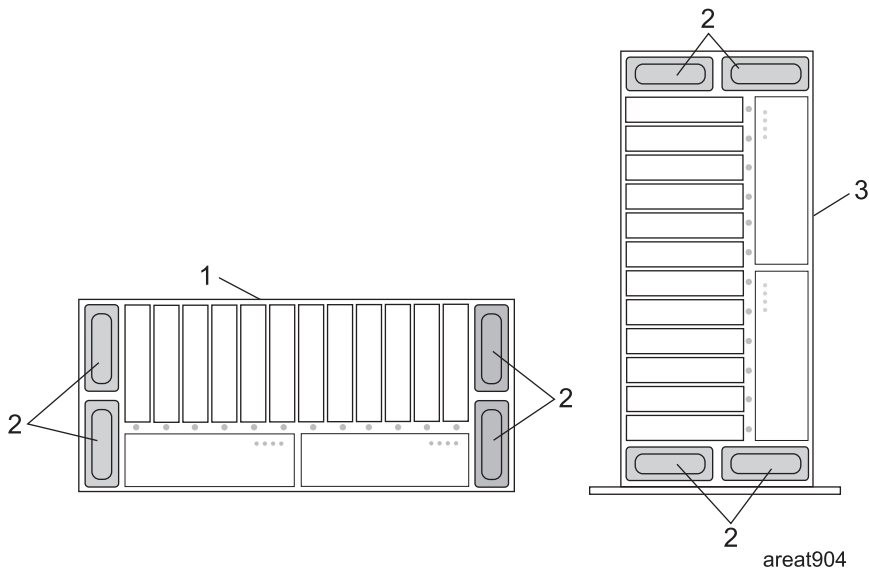

Figure 5. SCSI repeater card locations, located on the back of your I/O enclosure

Index number	Description
1	5786, 7031-D24 disk I/O enclosure (back of rack drawer configuration)
2	SCSI repeater card locations
3	5787, 7031-T24 disk I/O enclosure (back of desk side configuration)

Cabling

The cables that connect the enclosures allow some flexibility in placing the drawer and desk side unit. Up to two disk drive enclosures can be connected to a system unit. For cabling information and specifications, go to cables.

Disk drive

Use this procedure to remove and replace a disk drive.

Your system can be powered off or powered on while you replace the disk drive. If the system is running, you can replace a disk drive with the power on. If the system is not running, or if the disk drive to be replaced is in the AIX® or Linux root volume group (rootvg) and it is not protected with either a redundant array of independent disks (RAID) or mirroring, use the procedure for replacing the disk drive with the power off.

1.

Do you want to replace the disk drive concurrently with system operations and the system unit powered on?

Yes No
↓ Go to step 3.

2.

Choose the procedure for the operating system running in the partition to which the disk drive resource is assigned.

For AIX, go to “Deactivating a disk drive by using AIX” on page 16.

For Linux, go to “Deactivating a disk drive by using Linux” on page 18.

For IBM i, go to “Replacing the disk drive by using IBM i” on page 10.

3.

The component will not be serviced concurrently. If this system is powered on, power it off before continuing.

When the system is powered off, disconnect the ac input source from the enclosure being serviced. Do not apply power to the enclosure until directed to do so in this procedure.

4.

Access the unit:

1. If necessary, open the front rack door or rear rack door. This is dependent on the location of the disk drive you are servicing.
 2. If necessary, when servicing a disk drive located in the front of your server or enclosure, remove the front cover, also referred to as the front bezel.
-

5.

Remove the disk drive by:

1. Unlock the disk drive handle by squeezing it and pulling it out toward you as shown.
2. Support the bottom of the disk drive as you slide it out of the system or expansion unit. Do not hold the disk drive by the handle.

The concurrent maintenance light for the slot turns off when you remove the disk drive.

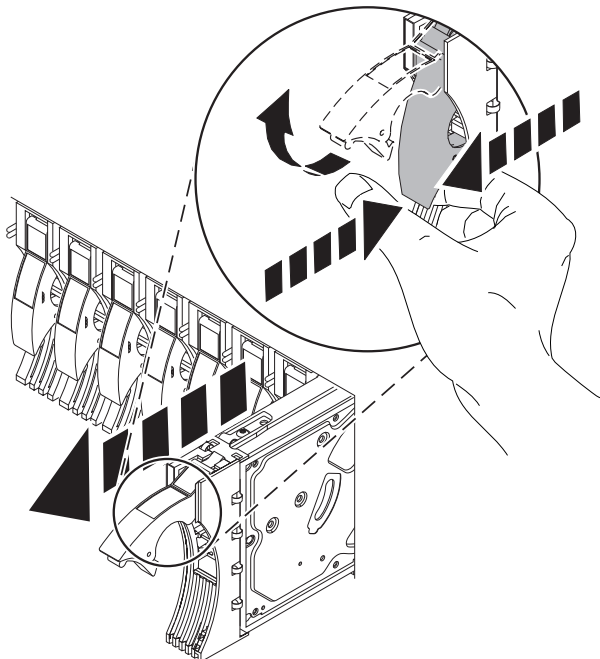

6.

Install the new disk drive:

1. Find the package that contains the new disk drive.
Attention: Disk drives are fragile. Handle with care.
2. Remove the disk drive from its static protective package.
3. Unlock the handle of the replacement disk drive by squeezing and pulling it out toward you. If the handle is not all the way out, the disk drive will not slide into the system.
4. Attach the disk drive bezel A to the replacement disk drive as shown.
5. Press in and then tighten the thumbscrew B to secure the bezel to the disk drive.

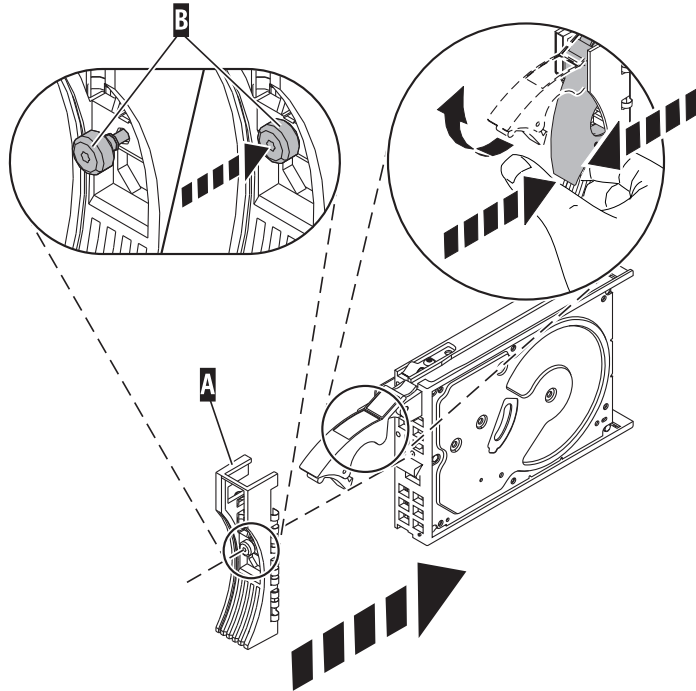

7.

Support the bottom of the disk drive as you align it with the guide rails in the system unit. Do not hold the disk drive by the handle.

8.

Slide the disk drive into the system until it stops.

9.

Push the disk drive handle in until it locks.

Note: Ensure that when you are installing a disk drive, that the drive is fully seated and all the way into the system.

10.

Reconnect the power source if you performed this procedure nonconcurrently (with the power off).

11.

Add the disk drive as a resource. Use the appropriate procedure:

- "Adding a disk drive as a resource by using AIX" on page 17
 - "Adding a disk drive as a resource by using Linux" on page 19
-

Replacing the disk drive by using IBM i

Use this procedure to remove and replace a disk drive concurrently with the IBM i operating system.

1.

Access the unit by:

1. If necessary, open the front rack door or rear rack door. This is dependent on the location of the disk drive you are servicing.
 2. If necessary, when servicing a disk drive located in the front of your server or enclosure, remove the front cover, also referred to as the front bezel.
-

2.

To recover any data that might be lost when a disk drive is replaced, you must know if the disk drive has data protection.

Do you know the protection status of the disk drive to be removed?

No: Continue with the next step.

Yes: If the disk drive is mirrored, record the status of both disk drives in the mirrored pair and go to step 5 on page 12. If the disk drive is parity protected, go to step 8 on page 13.

3.

Determine the protection status of the disk drive to be removed:

1. Sign on the operator console with at least service level authority.
2. Type `strsst` on the command line of the IBM i session and press Enter.
3. Type your service tools user ID and service tools password on the Start Service Tools (STRSST) Sign On display. Press Enter.
4. Select **Work with disk units** from the System Service Tools (SST) display. Press Enter.
5. Select **Display Disk Configuration** from the Work with Disk Units display. Press Enter.
6. Select **Display Disk Configuration Status** from the Display Disk Configuration display. Press Enter.
A list of each auxiliary storage pool (ASP) displays, showing the disk drives that are members of the ASPs.
7. Is the status of the failing disk drive **Mirrored**?

No: Continue with the next step.

Yes: Record the status of both disk drives in the mirrored pair and continue at step 5 on page 12.

4.

Determine if the failing disk drive is parity protected:

Note: An ASP with a status of Unprotected might contain disk drives that are device parity protected.

Check the status of the failing disk drive for one of the following:

- DPY/Active
- DPY/Failed
- DPY/HDW Failure
- DPY/Degraded
- DPY/Power Loss
- DPY/Not Ready
- DPY/Unknown

If the status of the failing disk drive and all other disk drives in the array is shown in the preceding list, the failing disk drive is parity protected.

Is the failing disk drive parity protected?

Yes: Go to step 8 on page 13.

No: The DASD can not be replaced concurrently. Go to "Disk drive" on page 8.

5.

Does the disk drive you are replacing have a status of Suspended?

Yes: Go to step 8 on page 13.

No: Check the status of the disk drive that is mirrored to the disk drive you are replacing. If it is Suspended, go to step 7. If it is Active, continue with the next step.

6.

Suspend the disk drive that you are replacing by performing the following:

1. Press F3 from the Display Disk Configuration display to return to the Work with Disk Units display.
 2. Select **Work with Disk Unit Recovery** from the Work with Disk Units display and press Enter.
 3. Select **Suspend mirrored protection** from the Work with Disk Unit Recovery display and press Enter.
 4. Select the option to suspend the disk drive that you are replacing from the Suspend Mirrored Protection display and press Enter.
 5. Go to step 8 on page 13
-

7.

The suspended mirrored pair of the failing drive has also failed and must be replaced.

Note: Performing a backup is a customer task. Refer to the system's operations information for instructions.

Perform a backup of the data in the failing ASP.

Go to step 8 on page 13 to replace the failing mirrored disk.

Return to the beginning of this procedure to replace the disk that you originally intended to replace.

8.

Select Device Concurrent Maintenance from the Hardware Service Manager display by:

1. Press F3 until the main SST menus is displayed.
 2. Select option 1 (Start a service tool). Press Enter
 3. Select option 7 (Hardware Service Manager). Press Enter
 4. Select option 8 (Device Concurrent Maintenance). Press Enter
 5. Enter the location code of the disk drive being replaced in the form of: U787A.001.AAAXXXX-P3-D4
 6. Select option 1 (Remove device) for the **Action to be performed**.
 7. Set the time delay for one minute: 01. **Important:** Do not press Enter at this time.
 8. Locate the concurrent maintenance light that corresponds to the position of the disk drive that you are replacing
Note: When you press Enter, after a one minute delay, this light comes on and begins to blink rapidly. You then have nine seconds to remove the disk drive.
 9. Press Enter on the console.
 10. When the light blinks rapidly, perform the next step to remove the disk drive within 9 seconds.
-

9.

Remove the disk drive by:

1. Unlock the disk drive handle by squeezing it and pulling it out toward you as shown.
2. Support the bottom of the disk drive as you slide it out of the system or expansion unit. Do not hold the disk drive by the handle.

The concurrent maintenance light for the slot turns off when you remove the disk drive.

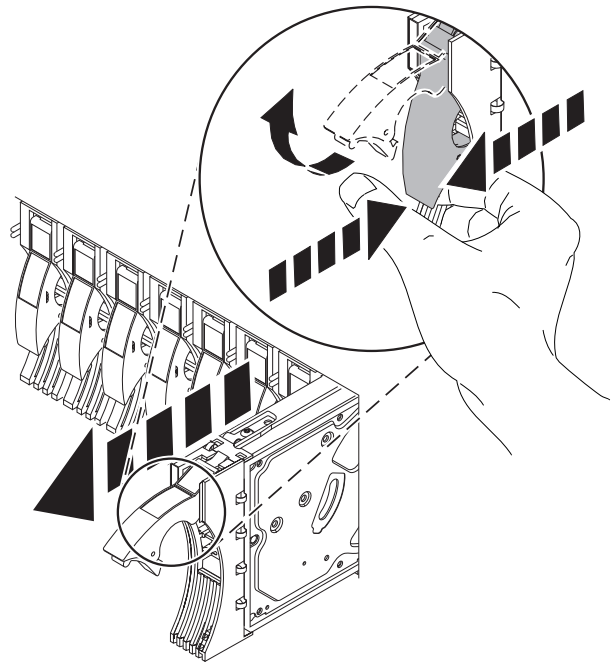

10.

Loosen and pull out on the thumbscrew B to release the disk-drive bezel C from the disk drive, as shown in the graphic.

Continue with the next step.

11.

Install the bezel on the new disk drive:

1. Find the package that contains the new disk drive.
Attention: Disk drives are fragile. Handle with care.
2. Remove the disk drive from its static protective package.
3. Unlock the handle of the replacement disk drive by squeezing and pulling it out toward you. If the handle is not all the way out, the disk drive will not slide into the system.
4. Attach the disk drive bezel A to the replacement disk drive as shown.
5. Press in and then tighten the thumbscrew B to secure the bezel to the disk drive.

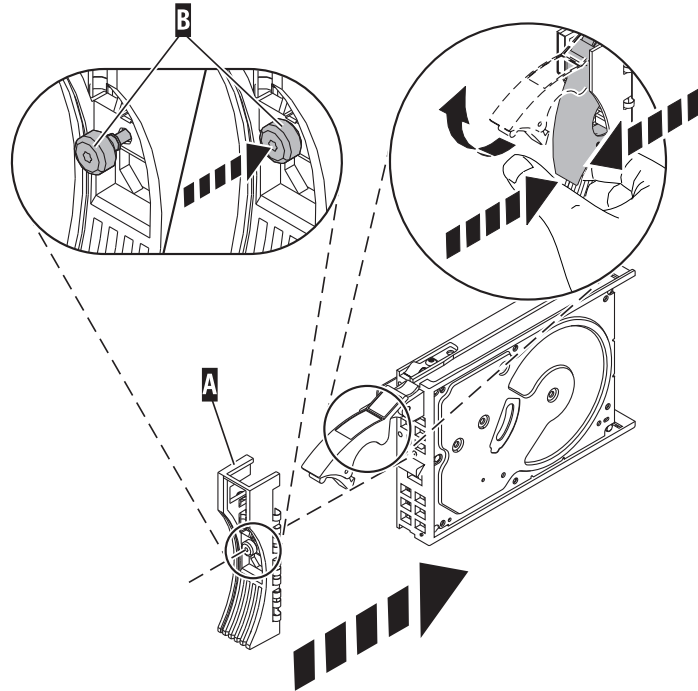

12.

1. Return to the console and wait until the Concurrent Maintenance Results display is shown. Press F12.
2. The physical locations you entered in step 6 of this procedure might still appear on the display. If not, retype the physical location where you will be installing the new disk drive.
3. Select option 2 (Install device) for the **Action to be performed**.
4. Set the time delay for one minute: 01.
Important: Do not press Enter at this time.
5. Locate the concurrent maintenance light that corresponds to the position of the disk drive that you are replacing
Important: When you press Enter, after a one minute delay, this light comes on and begins to blink rapidly. You then have nine seconds to install the disk drive.
6. Continue with the next step.

13.

Install the disk drive:

1. Support the bottom of the disk drive as you align it with the guide rails in the system unit. Do not hold the disk drive by the handle.
2. Slide the disk drive into the system until it stops.
3. Press Enter on the console.
4. When the light blinks rapidly, perform the next step to install the disk drive within 9 seconds.
5. Push the disk drive handle in until it locks.
Note: It is important to ensure that when installing a disk drive, that the drive is fully seated and all the way into the system.
6. Continue with the next step.

14.

1. If you removed a front cover, install the front cover
 2. Install or close the system, expansion unit or rack front door.
 3. Return to the console and wait until the Concurrent Maintenance Results display is shown. Press Enter.
 4. If you return to the Service Action Log display, exit the service action log.
 5. When the Hardware Service Manager display is shown, press F3.
 6. Continue with the next step.
-

15.

Rebuild the data on the replacement disk drive by:

1. If necessary, start System Service Tools (SST) by typing strsst on the command line of the IBM i session and pressing Enter.
2. Type your service tools user ID and service tools password on the Start Service Tools (STRSST) Sign On display. Press Enter. **Note:** The service tools password is case sensitive.
3. Select **Work with disk units** from the Start System Service Tools (SST) display. Press Enter.

Was the failing disk drive mirrored?

Yes: Go to step 19 on page 16.

No: Continue with the next step.

16.

Did the array have a hot spare installed before the failure occurred?

No: Go to step 18.

Yes: Continue with the next step.

17.

Perform the following:

1. Select **Non-configured disk units** from the Work with Disk Units display. Press Enter.
 2. Is the new disk unit displayed with a status of non-configured?
Note: It may take several minutes for the new disk drive to be displayed.
No: Contact your next level of support.
Yes: Continue with the next step.
 3. Press F3 to return to the Work with Disk Units display.
 4. Select **Work with disk unit recovery** from the Work with Disk Units display. Press Enter.
 5. Select **Disk unit problem recovery procedure**. Press Enter.
 6. Select **Initialize and format disk unit**. Press Enter.
 7. Select the new disk and press Enter.
Note: This will take several minutes to complete.
 8. When the disk drive is initialized and formatted, press F3 to return to the Work with Disk Units display.
 9. Select **Start hot spare**. Press Enter.
 10. Select the IOA with the new disk. Press Enter and press Enter again.
Note: This will take several minutes to complete.
 11. Press F3 (Exit) to return to the System service tools display.
 12. Press F3 (Exit) to return to the Exit SST display and press Enter. **This completes this procedure.**
-

18.

Perform the following:

1. Press F3 to return to the Work with Disk Units display.
 2. Select **Work with disk unit recovery** from the Work with Disk Units display. Press Enter.
 3. Select **Rebuild disk unit data** on the Work with Disk unit recovery display. Press Enter.
 4. Select 1 to rebuild the disk drive displayed (the disk drive displayed is the disk drive that you removed) on the Rebuild Disk Unit Data display. Press Enter.
 5. Press Enter on the Confirm Rebuild Disk Unit Data display. The rebuild process might take several minutes to complete.
 6. Press F5 to refresh the display until the **Percent complete** shows 5%.
 7. When the display shows at least 5% complete, you can either continue to monitor this display to completion, or press F3 (Exit) to return to the Work with disk units display.
 8. Press F3 (Exit) to return to the System service tools display.
 9. Press F3 (Exit) to return to the Exit SST display and press Enter.
-

19.

1. Select **Work with disk unit recovery** from the Work with Disk Units display. Press Enter.
 2. Select **Replace configured unit** on the Work with Disk unit recovery display. Press Enter.
 3. Select the configured disk drive that you are exchanging (suspended drive) on the Select Configured Unit to Replace display. Press Enter.
 4. Select the disk drive that you just installed on the Select Replacement Unit display. This drive has a non-configured status.
Note: In some cases, it might take several minutes for a new disk drive to display. Repeat these steps until the new drive is shown.
Press Enter.
 5. Press Enter on the Confirm Replace of Configured Unit display to confirm your choice for replacement.
The replacement process might take several minutes to complete.
When the process is complete, the Work with Disk unit recovery display is shown.
 6. Press F3 (Exit) to return to the Work with disk units display.
 7. Select **Display disk configuration** on the Work with disk units display.
 8. Select **Display disk configuration status** on the Display Disk Configuration display.
Mirrored status shows Resuming. When complete, the mirrored status shows Active. This process might take several minutes to complete. You can either monitor this display to completion, or press **F3** (Exit) three times, and then press Enter to return to the main menu.
-

20.

Go to “MAP 2410: Repair verification” on page 42 to verify the repair. For a server-level repair verification, go to your host server's service information. **This completes this procedure.**

Deactivating a disk drive by using AIX

Concurrent maintenance can be accomplished on disk drives without removing power to either the enclosure or the server. Use the following procedure in conjunction with the removal and replacement procedures to concurrently remove or replace a disk drive using the AIX operating system.

To deactivate the disk drive and disk drive slot and do concurrent maintenance on your disk drives, do the following steps:

1. Log in as root user or use CE Login.
2. At the command line, type **diag** and press Enter.
3. Press Enter to continue.

4. On the Function Selection display, select **Task Selection**.
5. Select **Hot Plug Task**.
6. Select **RAID Hot Plug Devices**.
7. Select the adapter that is connected to the array that contains the disk drive you want to deactivate and press Enter.
8. Select **Commit**.
9. On the Identify and Remove Resources display, select **Identify**.
10. Select the disk drive you want to remove and press Enter.
The disk drive slot enters the Identify state. The concurrent maintenance light for the slot begins flashing. Verify that the flashing light corresponds to the location for the disk drive you want to deactivate, and press Enter.
The disk drive slot exits the Identify state.
11. On the Identify and Remove Resources display, select **Remove**.
A list of the disk drives that you can remove is displayed. If the disk drive is not displayed in the list, ask your system administrator to put the disk drive in the Failed state before continuing with this procedure. For information, see the system-management topics in the IBM System p and AIX Information Center at: <http://publib.boulder.ibm.com/infocenter/pseries/v5r3>
12. Select the disk drive you want to deactivate and press Enter.
The disk drive slot enters the Remove state and power is removed from the slot. The concurrent maintenance light for the slot begins flashing rapidly.
13. If you are removing a disk drive from your system, go back to Disk drive and complete the disk drive hardware removal portion of this procedure.

Adding a disk drive as a resource by using AIX

After replacing or installing a disk drive, use this procedure to have the system add the disk drive as a resource.

After replacing or installing a disk drive, you *must* add the new disk drive as a resource. To add the disk drive as a resource, do the following steps:

1. Press Enter.
The disk drive slot exits the Remove state and enters the Normal state.
2. Exit to the RAID Hot-Plug Devices menu. Press the F3 or simultaneously press Esc+3.
3. Exit to the Task selection display.
4. Select **Log Repair Action**.
5. Select the disk drive that you replaced and then press Enter.
6. Select **Commit** and then press Enter.
7. Exit to the command line.
8. Go to Verify a repair in your host server's service information. **This completes this procedure.**

Note: To rebuild data on the replacement disk drive, refer to the information for the controller to which the disk drive is attached.

- If the disk drive is attached to a PCI-X SCSI RAID controller, see the *PCI-X SCSI RAID Controller Reference Guide for AIX*.
- If the disk drive is attached to a PCI SCSI RAID adapter (feature code 2498), see the *PCI 4-Channel Ultra3 SCSI RAID Adapter Reference Guide*.

Deactivating a disk drive by using Linux

Concurrent maintenance can be accomplished on disk drives without removing power to either the enclosure or the server. Use the following procedure in conjunction with the removal and replacement procedures to concurrently remove or replace a disk drive using Linux.

You must have the Linux 2.6 kernel installed.

1. Log in as root user.
2. Type `iprconfig` on the command line of the Linux session and press Enter.
The IBM Power RAID Configuration Utility opens.
3. Select **Analyze log** and press Enter. The Kernel Messages Log display is shown.
4. Select **View most recent ipr error messages** from the Kernel Messages Log display. Press Enter.
5. Find the entry in the log for the disk drive you want to deactivate.
6. Record the location information for the disk drive.

Note: The location information has the form of 2:0:8:0. In this example, 2 is the SCSI host number, 0 is the SCSI bus, 8 is the SCSI target ID, and 0 is the LUN (logical unit).

7. Return to the command line.
8. Type the following code phrase:
`ls -ld /sys/class/scsi_host/host#/device`
where # is the SCSI host number. Press Enter.
9. Record the PCI location information.

Note: The PCI location information has the form of 61:01:0:2.

10. Type `iprconfig` on the command line and press Enter.
The IBM Power RAID Configuration Utility display opens.
11. Select **Display hardware status** from the IBM Power RAID Configuration Utility display. Press Enter.
The Display Hardware Status display is shown.
12. Look for the disk drive at the PCI location you recorded. The disk drive might have a Failed status.
13. If the disk drive you want to deactivate is unprotected or in use, move the data from the disk drive before continuing with this procedure.
For information, see the *PCI-X SCSI RAID Controller Reference Guide for Linux*.
14. Type option 1 (Display hardware resource information details) next to the disk drive you want to deactivate. Press Enter.
Disk Hardware Resource Information Details display.
15. Record the physical location information.
16. Return to the IBM Power RAID Configuration Utility display.
17. From the IBM Power RAID Configuration Utility display, select **Work with disk unit recovery**. Press Enter.
18. From the Work with Disk Unit Recovery display, select **Concurrent remove device**. Press Enter. A Concurrent Device Remove display is shown.
19. Select option 1 next to the location for the disk drive you want to deactivate. Press Enter.
20. The Verify Device Concurrent Remove display is shown. The concurrent maintenance light turns on for that disk drive slot.
21. On the Verify Device Concurrent Remove display, verify that the selected disk drive is the disk drive you want to deactivate, then press Enter. The identify light turns on for the disk drive.
Attention: Ensure that the disk drive is not in use to prevent loss of data.
The Complete Device Concurrent Remove display is shown.

Attention:

- Attach a wrist strap to an unpainted surface of your hardware to prevent electrostatic discharge (ESD) from damaging your hardware.
 - When using a wrist strap, follow all electrical safety procedures. A wrist strap is for static control. It does not increase or decrease your risk of receiving electric shock when using or working on electrical equipment.
 - If you do not have a wrist strap, just prior to removing the product from ESD packaging and installing or replacing hardware, touch an unpainted surface of the system for a minimum of 5 seconds.
22. Press Enter on the IBM Power RAID Configuration Utility to indicate that you have deactivated the disk drive.
 23. If you are removing a disk drive from your system, go back to Disk drive and complete the disk drive hardware removal portion of this procedure.

Adding a disk drive as a resource by using Linux

After replacing or installing a disk drive, use this procedure to have the system add the disk drive as a resource.

After replacing or installing a disk drive you *must* add the new disk drive as a resource.

To add the disk drive as a resource using Linux, do the following steps:

1. From the IBM Power RAID Configuration Utility display, select **Work with disk unit recovery**. Press Enter.
2. From the Work with Disk Unit Recovery display, select **Concurrent add device**. Press Enter. A Concurrent Device Add displays.
3. Type select 1 next to the location from which you removed the disk drive. The Verify Device Concurrent Add display is shown.
4. Press Enter on the Verify Device Concurrent Add display. The Complete Device Concurrent Add display is shown.
5. Press Enter on the Complete Device Concurrent Add display to indicate that the disk drive is installed.
6. Rebuild the data on the replacement disk drive. For instructions, go to Rebuild data on a replacement disk drive by using Linux.
7. Go to Verify a repair. **This completes this procedure.**

Rebuild data on a replacement disk drive using Linux

You can rebuild data on the replacement disk drive that was replaced because of a failed disk drive or a new installation.

For an unprotected disk drive

If the disk drive you are replacing is in a RAID Level 0 disk array or in a failed RAID Level 5 or RAID Level 10 disk array, perform these tasks:

1. Re-create the disk array.
2. Re-create the file systems on the disk array.
3. Copy the data back to the restored disk array from your backup media.

For information on these tasks, see the *PCI-X SCSI RAID Controller Reference Guide for Linux*. This guide is available from the SCSI PCI Adapters web page.

For a disk drive in a RAID Level 5 or RAID Level 10 disk array, select the appropriate procedure.

Fan

Use this procedure to service the fan.

You can service the fan concurrently (powered on) or non-concurrently (powered off). To service the fan concurrently, go to step 1, otherwise go to step 2.

1.

The component will be serviced concurrently. Power should not be removed from the unit containing the FRU in the location field above during this procedure. Go to step 3.

2.

The failing component will not be replaced concurrently. Power should be removed from the enclosure containing the FRU in the location field above. If this enclosure is powered on, power it off now. Do not apply power to the enclosure until directed to do so in this procedure.

3.

Attention: Failure to follow the step-by-step sequence for this FRU removal or installation may result in FRU or system damage.

Use the following precautions whenever you handle electronic components or cables.

- Attach a wrist strap to an unpainted metal surface of your hardware to prevent electrostatic discharge from damaging your hardware.
 - If you do not have a wrist strap, just prior to removing the product from ESD packaging and installing or replacing hardware, touch an unpainted metal surface of the system for a minimum of 5 seconds.
 - Keep all electronic components in the shipping container or envelope until you are ready to install them.
 - If you remove, then re-install an electronic component, temporarily place the component on an ESD pad or blanket, if available.
-

4.

1. Loosen the screws and move the slider bar to the left. Press down on the handle (A) of the failing fan unit to release it from its slot in the system unit.
2. Pull gently on the fan handle until the fan is dislodged from the system.
3. Grasp the front of the fan and pull it out from the system unit, supporting the bottom of the fan as you do this.

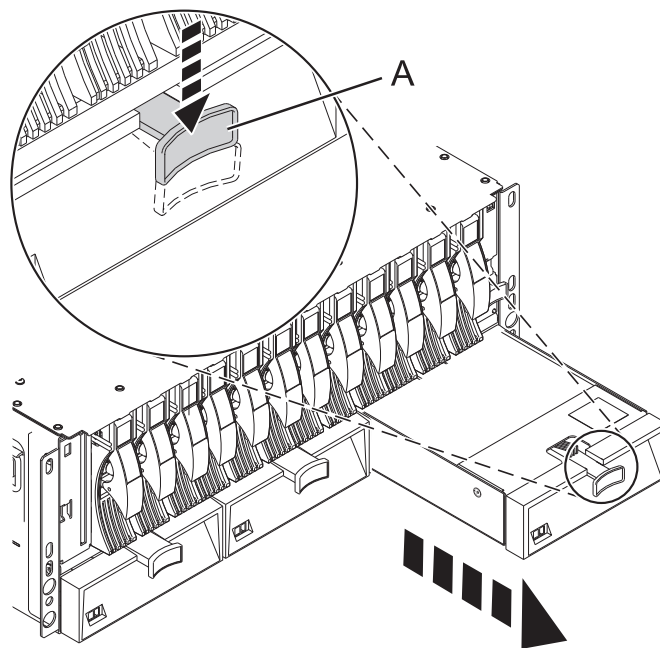

5.
 1. Align the fan with its slot in the system unit.
 2. Gently push the fan into the system unit.
 3. Press on the fan to ensure that it is completely seated. The fan starts to run when it is correctly installed.
 4. Move the slider bar to the right and tighten the screws.

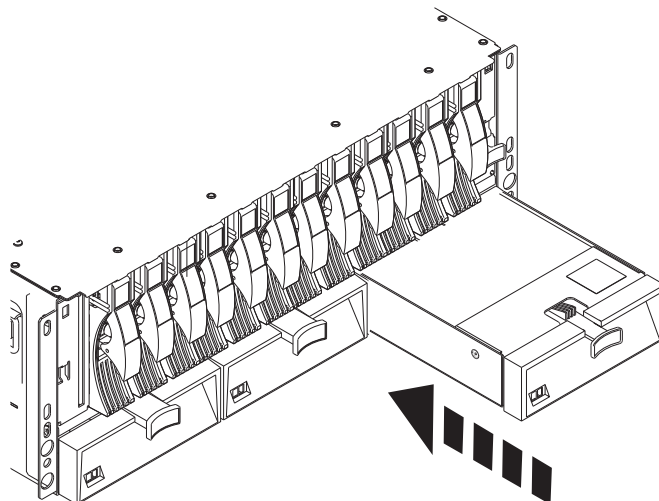

-
6. Go to “MAP 2410: Repair verification” on page 42 to verify the repair. For a server level repair verification, go to your host server's service guide. **This completes this procedure.**

Power supply

Use this procedure to service the power supply.

- 1.

You may service the power supply concurrently or non-concurrently. To service the power supply concurrently, begin with Step 2. Otherwise, begin with Step 3.

- 2.

The component will be serviced concurrently. Power should not be removed from the unit containing the FRU in the location field above during this procedure. Go to step 4.

- 3.

The failing component will not be replaced concurrently. Power should be removed from the enclosure containing the FRU in the location field above. If this enclosure is powered on, power it off now. Do not apply power to the enclosure until directed to do so in this procedure.

- 4.

Attention: Failure to follow the step-by-step sequence for this FRU removal or installation may result in FRU or system damage.

Use the following precautions whenever you handle electronic components or cables.

- Attach a wrist strap to an unpainted metal surface of your hardware to prevent electrostatic discharge from damaging your hardware.
 - If you do not have a wrist strap, just prior to removing the product from ESD packaging and installing or replacing hardware, touch an unpainted metal surface of the system for a minimum of 5 seconds.
 - Keep all electronic components in the shipping container or envelope until you are ready to install them.
 - If you remove, then re-install an electronic component, temporarily place the component on an ESD pad or blanket, if available.
-

5.

1. Press the power switch (A) on the left side of the cable.
2. Release the power cable lock by pushing the bracket (C) down.
3. Unplug and remove the power cable from the system.
4. Lift the release tab (D) until the power supply is unseated.
Note: If service is being done concurrently, the second power supply remains connected to its power source. If service is not being done concurrently, and the system has a second power supply installed, ensure that the power source to the second power has also been disconnected.
5. Gently pull the power supply out of the system.

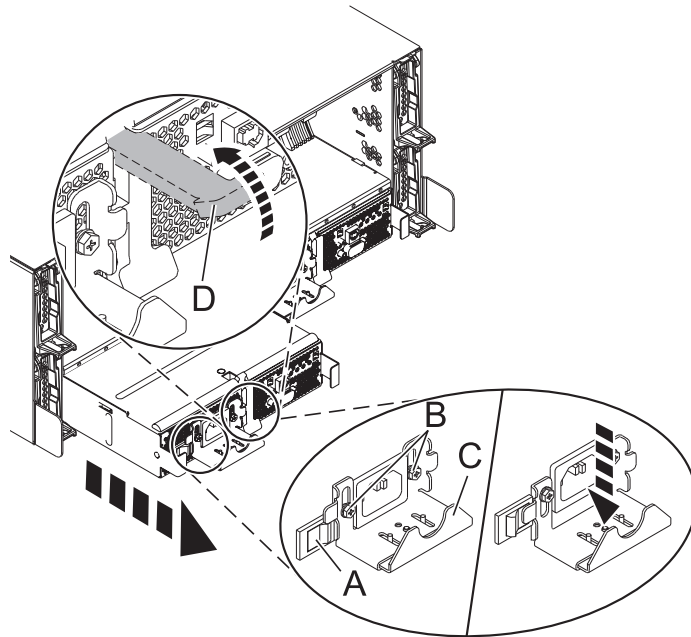

6.

1. Align the power supply with its bay in the rear of the system.
2. Slowly push the power supply all the way into the system.
3. Push down on the power supply release tab (D) to secure the power supply.
4. Reconnect the power cable into the back of the replacement power supply.
5. Lift up on the cable bracket (C) and if necessary, tighten the screws (B).
6. Press the power switch (A) to lock the cable bracket into place.

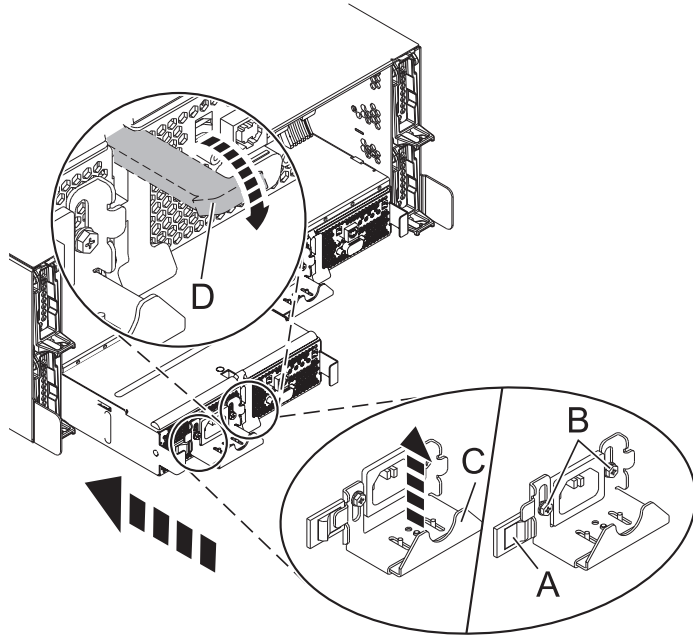

Note the state of the LEDs on the power supply. If the LEDs indicate that the power supply is not operating normally, that is, both of the green LEDs are on solid (not blinking), remove the power supply from the system and re-install it. Do not proceed until the LEDs indicate that the new power supply is operating normally.

7. Ensure the system cables are routed correctly through the cable-management arm.
8. Reconnect any remaining cables.

-
7. Go to “MAP 2410: Repair verification” on page 42 to verify the repair. For a server level repair verification, go to your host server's service guide. **This completes this procedure.**
-

SCSI repeater card

Use this procedure to service the SCSI repeater card.

Before you remove and replace a SCSI repeater card, follow the instructions for your operating system to save any jobs. For IBM i, power off the partition to save any jobs.

Important: The I/O adapter (IOA) needs to be powered off before disconnecting or reconnecting cables or before removing or replacing the repeater card. The IOA can be powered off by powering off the IOA slot or the logical partition. Depending on the disk protection level, the system or logical partition might be affected during the service procedure. For additional information, see *Installing PCI adapters*.

Restriction: You must replace the repeater card with the same type of card to continue. If you are changing card configurations from single repeater cards to dual repeater cards, stop here and follow the instructions in *Connecting the 5786, 5787, 7031-D24, or 7031-T24 to a system that has an AIX operating system* or *Connecting and configuring the disk drive enclosure in a system that has a Linux operating system*.

The disk drive enclosure SCSI repeater card can be removed and replaced with the system and enclosure power on. To avoid errors, you must power off the adapter that connects the disk drive enclosure to your system.

To remove and replace a SCSI repeater card, complete the following steps.

- 1.

Attention: Failure to follow the step-by-step sequence for this FRU removal or installation may result in FRU or system damage.

Use the following precautions whenever you handle electronic components or cables.

- Attach a wrist strap to an unpainted metal surface of your hardware to prevent electrostatic discharge from damaging your hardware.
 - If you do not have a wrist strap, just prior to removing the product from ESD packaging and installing or replacing hardware, touch an unpainted metal surface of the system for a minimum of 5 seconds.
 - Keep all electronic components in the shipping container or envelope until you are ready to install them.
 - If you remove, then re-install an electronic component, temporarily place the component on an ESD pad or blanket, if available.
-

2.

Note: Before removing the SCSI cables from a dual ported SCSI repeater card, note the location of each cable.

1. Remove all SCSI cables (A) from the SCSI repeater card that you are servicing.
2. Lift up on the tab located on the bottom of the locking latch (B) that frames the outer edge of the SCSI repeater card. This action pulls the SCSI repeater card out of its connector on the disk drive backplane.
3. After the SCSI repeater card is fully loose, pull it out from the system unit.

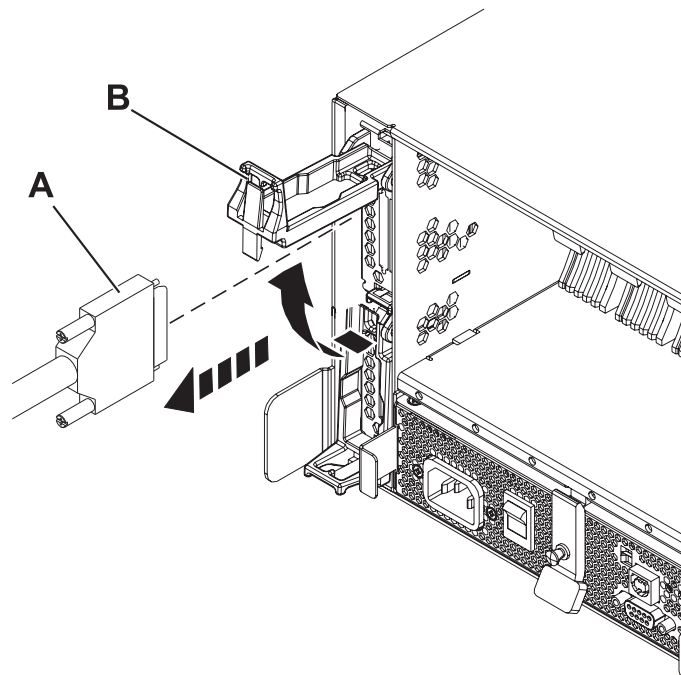

3.

1. Align the SCSI repeater card with its slot in the system unit.
2. Make sure that the locking latch (B) is raised in the unlocked position.
3. Push the SCSI repeater card fully into the system.
4. Make sure that it is fully seated, with a firm connection to the disk drive backplane.
5. Push down on the locking latch (B) to secure the SCSI repeater card in position.
6. Reconnect the SCSI cable (A) to the SCSI repeater card in the attached server.

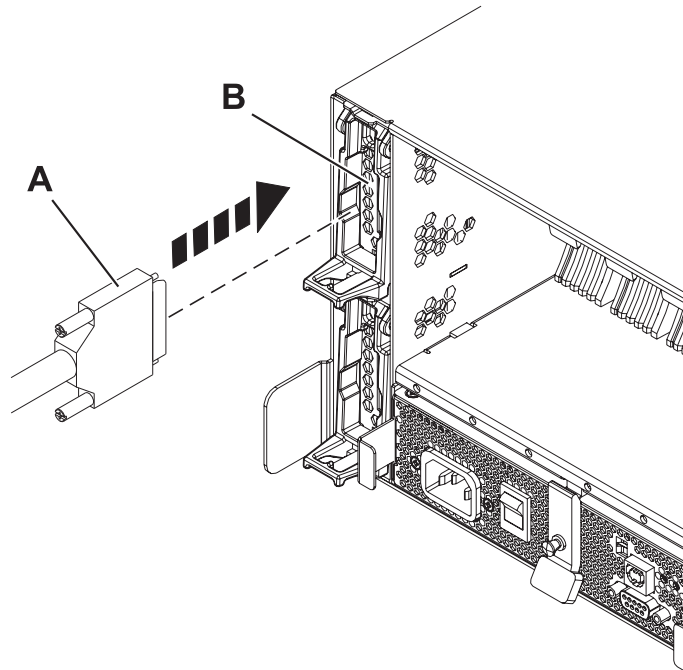

-
4. Restart the adapter. See Installing PCI adapters.
 5. For 7031-D24 or 7031-T24, go to "MAP 2410: Repair verification" on page 42 to verify the repair. For a server level repair verification, go to your host server's service guide. **This completes this procedure.**

Chassis assembly (chassis, enclosure backplane, and VPD card)

Provides instructions for exchanging the chassis assembly. The chassis assembly for this I/O enclosure consists of the chassis, backplane and VPD card.

To install a new chassis assembly, refer to the installation instructions that are packaged with the new chassis. After following the removal and replacement procedures for the chassis assembly, ensure that you go to "MAP 2410: Repair verification" on page 42 to verify the repair. For a server level repair verification, go to your host server's service information. **This completes this procedure.**

Problem determination procedures

Problem determination procedures are provided by power-on self-tests (POSTs), service request numbers, and maintenance analysis procedures (MAPs). Some of these procedures use the service aids that are described in the user or maintenance information for your system SCSI attachment.

Disk drive module power-on self-tests

The disk drive module Power-on Self-Tests (POSTs) start each time that the module is switched on, or when a Send Diagnostic command is received. They check whether the disk drive module is working correctly. The POSTs also help verify a repair after a Field Replaceable Unit (FRU) has been exchanged.

The tests are POST-1 and POST-2.

POST-1 runs immediately after the power-on reset line goes inactive, and before the disk drive module motor starts. POST-1 includes the following tests:

- Microprocessor
- ROM
- Checking circuits

If POST-1 completes successfully, POST-2 is enabled.

If POST-1 fails, the disk drive module is not configured into the system.

POST-2 runs after the disk drive module motor has started. POST-2 includes the following tests:

- Motor control
- Servo control
- Read and write on the diagnostic cylinder (repeated for all heads)
- Error checking and correction (ECC).

If POST-2 completes successfully, the disk drive module is ready for use with the system.

If POST-2 fails, the disk drive module is not configured into the system.

SCSI card power-on self-tests

The SCSI card Power-On Self Tests (POSTs) start each time power is switched on, or when a Reset command is sent from the using system SCSI attachment. They check only the internal components of the SCSI card; they do not check any interfaces to other FRUs.

If the POSTs complete successfully, control passes to the functional microcode of the SCSI card. This microcode checks all the internal interfaces of the I/O enclosure, and reports failures to the host system.

If the POSTs fail, one of the following events occur:

- The SCSI card check LED and the enclosure check LED come on.
- If the SCSI was configured for high availability using a dual initiator card the error will be reported. However, the functional operation of the enclosure is not affected. For example, the customer still has access to all the disk drive modules.

The failure is reported when:

- the failure occurs at system bring-up time, the host system might detect that the enclosure is missing, and reports an error.
- the failure occurs at any time other than system bring-up time, the hourly health check reports the failure.

Component and attention LEDs

This topic provides detailed information on the use of component and attention LEDs.

The component and attention LEDs assist in identifying failing components in your I/O enclosure. If a failing component is detected in your enclosure, an amber colored LED on or near the failing component is lit. Use the information in this topic along with the "Start of call" procedure, located in your host system's service information, to isolate the failing component.

LEDs are either green or amber. The LEDs are typically located on the component.

Green LEDs indicate either of the following:

- Electrical power is present.
- Activity is occurring on a link. (The enclosure is either sending or receiving information.)

Amber LEDs indicate a fault or identify condition. If your enclosure or any of its components in your enclosure has an amber LED turned on or blinking, identify the problem and then take the appropriate action to restore the enclosure to its normal operating state.

The following definition list identifies, defines, and explains the on and off state of each LED. Following the definition list are two illustrations that show the location of each LED.

Disk drive enclosure status LEDs

The two disk drive enclosure status LEDs indicate the following:

- Power good LED - (solid, not blinking) when lit this green colored LED indicates that the disk-drive enclosure is receiving dc electrical power.
- Cage Fault LED - (solid, not blinking) when lit this amber colored LED indicates that one of the components located in the disk-drive enclosure has failed.

Note:

- The failing component can be located either on the front or the rear of the subsystem.
- The disk-drive enclosure might be able to continue operating satisfactorily although the failure of a particular part has been detected.

Disk drive LEDs

Up to twenty four disk drives can be installed into the front and back of the disk-drive enclosure (twelve disk drives per side). Each disk drive contains three LEDs that are visible via light pipes. The light pipes are attached to the disk-drive carrier and extend out the left side of each disk drive.

- Disk drive activity LED (green) - The disk drive activity LED is controlled by the disk. For most disk drives the green LED is lit when the disk is processing a command. However, for some disk drives a different mode page setting allows the green LED to be lit when the disk drive motor is spinning and the LED blinks toward an off state when a command is in progress.
- Disk drive fault LED (amber) - The disk fault LED is controlled by the SES processor on the SCSI card. The disk drive fault LED can be viewed in one of the following three states:
 - Off - This is the normal state for the disk-drive fault LED
 - On - (solid, not blinking) indicates one of the following:
 - A drive is to be removed

- The disk drive is faulty
- Appears on an empty slot where a drive is to be installed
- Blinking - The disk drive is rebuilding
- Disk drive identify (green) - The light pipe for this LED is located on the lower left side of the disk drive and is used for the identify function by disk-drive enclosures that are connected to an IBM System i systems.

Power supply LEDs

This disk drive enclosure contains two power supplies and they are located on the back lower third portion of the chassis. The power supply located on the left of the chassis is power supply 1. The power supply located on the right side of the chassis is power supply 2. Each power supply contains four LEDs located on the lower right side. The following list identifies and defines each of the power supply LEDs.

- Cage fault LED - This is an amber colored LED and is labeled C/F. The power supply cage fault LED provides the same information as the cage fault indicator located on the front of the enclosure.
- AC good LED - This a green colored LED and is labeled I/G
- DC power good LED - This green colored LED is labeled D/G. Indicates that the enclosure is getting good dc power. It is on when +1.8 V, +3.3 V, +5 V, and +12 V are good. It goes off when any of the mentioned voltages are not good.
- Power supply fault LED - This amber colored LED is labeled FLT and comes on solid when there is a fault with the power supply.

The following table explains the fault condition or power supply state indicated by each power supply LED:

Table 1. Power supply fault condition

LED name	Normal operation state	Input not present state	Input present state	Fault state
Cage fault LED	OFF	OFF	ON	
AC good LED	ON	OFF	ON	ON
DC power good LED	ON	OFF	OFF	OFF
Power supply fault LED	OFF	OFF	ON	OFF

Fan assembly LEDs

The three disk-drive enclosure fan assemblies are located on the front lower third of the enclosure chassis. There are two LEDs located on each fan. The green colored LED is lit when power to the fan is present. The second LED is amber colored when lit and comes on when the fan needs to be replaced.

Note:

- The fan does not need to be completely dead before the fan fault LED is lit. The fan can be turning either to slow or to fast indicating to the system that it is having a problem.
- The fans green LED will remain lit even when the amber LED is indicating a fan fault.

SCSI card LEDs

Each SCSI card has a green and amber colored LED. The green colored LED indicates that activity is taking place through the card. The amber colored LED is used as an identify LED and indicates which one of the SCSI cards needs to be replaced.

The following two figures show the location of each LEDs found on your I/O enclosure.

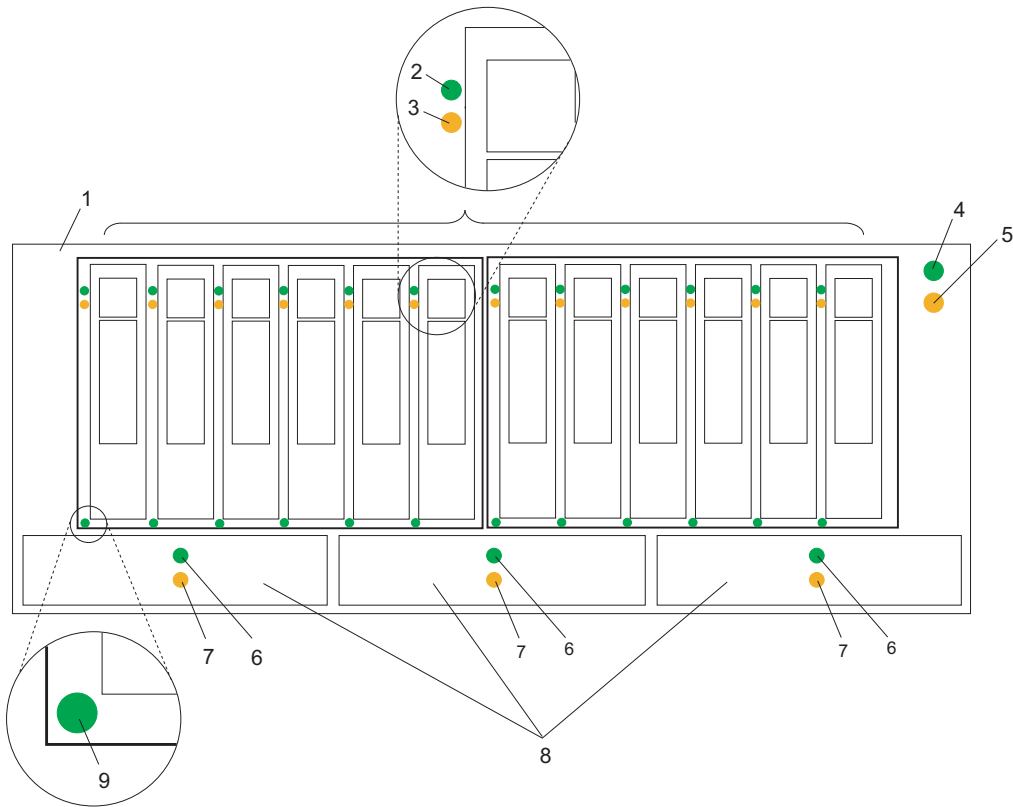

Figure 6. I/O enclosure front view showing maintenance LEDs

Index Number	Component LED	Index Number	Component LED
1	7031-D24 or 7031-T24	6	Fan power LED
2	Disk drive activity LED	7	Fan fault LED
3	Disk drive fault LED	8	Fan assembly
4	Status panel power good LED	9	Disk drive identify LED (activated on System i models only)
5	Status panel cage fault LED		

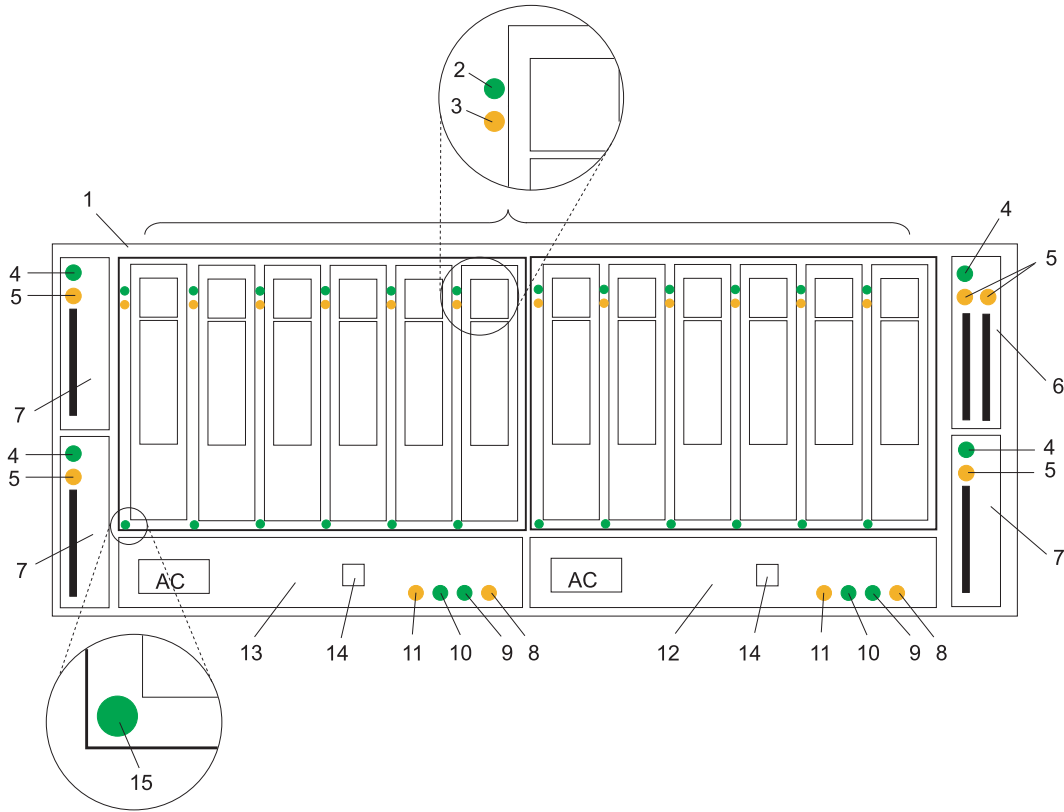

Figure 7. I/O enclosure rear view showing maintenance LEDs

Index Number	Component LED	Index Number	Component LED
1	7031-D24 or 7031-T24	9	Power supply dc power good LED
2	Disk drive activity LED	10	Power supply ac power good LED
3	Disk drive fault LED	11	Cage fault LED
4	SCSI card fault LED	12	Power supply 2
5	SCSI card activity LED	13	Power supply 1
6	Dual initiator SCSI card	14	Rack indicator connector
7	Single initiator SCSI card	15	Disk drive identify LED (activated on System i models only)
8	Power supply fault LED		

Maintenance analysis procedures

The maintenance analysis procedures (MAPs) in this document give detailed instructions about how to analyze a continuous failure that has occurred in your disk drive I/O enclosure that contains one or more SCSI disk drive modules.

For more information about additional tools to identify missing resources on Linux, go to “Linux tools.”

Using the MAPs

Attention: Do not remove power from the host system or enclosure unless you are instructed to do so. Power cables and external SCSI cables that connect your enclosure to the host system can be disconnected while that system is running.

To isolate the FRUs in the failing enclosure, perform the following actions and answer the questions given in these MAPs:

1. When instructed to exchange two or more FRUs in sequence:
 - a. Exchange the first FRU in the list for a new one.
 - b. Go to “MAP 2410: Repair verification” on page 42 to verify the repair. For a server level repair verification, go to your host server's service guide.
 - c. If the problem remains:
 - 1) Reinstall the original FRU.
 - 2) Exchange the next FRU in the list for a new one.
 - d. Repeat steps 1b and 1c until either the problem is solved, or all the related FRUs have been exchanged.
 - e. Perform the next action that the MAP indicates.
2. Refer to “Component and attention LEDs” on page 28 often when servicing your server and enclosure. The LEDs are one of the diagnostic tools used by your server and enclosure to aid you in identifying failing components. They are also used to identify specific component locations on your system.

Attention: Disk drive modules are fragile. Handle them with care, and keep them well away from strong magnetic fields.

Linux tools

Use the `lscfg` command to list all the resources that are available at startup. This information is also saved at each startup, and you can use it to identify any missing resources.

To determine if any devices or adapters are missing, compare the list of found resources and partition assignments to the customer's known configuration. Record the location of any missing devices. You can also compare this list of found resources to a prior version of the device tree as the following example shows.

When the partition is restarted, the update device tree command is run and the device tree is stored in the `/var/lib/lsvpd/` directory in a file with the file name device tree `YYYY-MM-DDHH:MM:SS`, where `YYYY` is the year, `MM` is the month, `DD` is the day, and `HH`, `MM`, and `SS` are the hour, minute and second, respectively, of the date of creation.

Type the following command at the command line: `cd /var/lib/lsvpd/`, then type the following command: `lscfg -vpd device-tree-2003-03-31-12:26:31`. This command displays the device tree that was created on 03/31/2003 at 12:26:31.

MAP 2010: 7031-D24 or 7031-T24 START

This MAP is the entry point to the MAPs for the 7031-D24 or 7031-T24.

If you are not familiar with these MAPs, read “Using the MAPs” on page 33 first.

You might have been directed to this section because:

- The system problem determination procedures sent you here.
- Action from an SRN list sent you here.
- A problem occurred during the installation of a 7031-D24 or 7031-T24 or a disk drive module.
- Another MAP sent you here.
- A customer observed a problem that was not detected by the system problem determination procedures.

Attention: Do not remove power from the host system or 7031-D24 or 7031-T24 unless you are told to in the instructions that you are following. Power cables and external SCSI cables that connect the 7031-D24 or 7031-T24 to the host system can be disconnected while that system is running.

1. Does the 7031-D24 or 7031-T24 emit smoke or is there a burning smell?

NO Go to step 2.

YES Go to “MAP 2022: 7031-D24 or 7031-T24 Power-on” on page 38.

2. Are you at this MAP because power is not removed completely from the 7031-D24 or 7031-T24 when the host systems are switched off?

Note: Power will remain on the 7031 for approximately 30 seconds after the last system is powered off.

NO Go to step 3.

YES Go to “MAP 2030: 7031-D24 or 7031-T24 power control” on page 40.

3. Have you been sent to this MAP from an SRN?

NO Go to step 4.

YES Go to step 7 on page 35.

4. Have the system diagnostics or problem determination procedures given you an SRN for the 7031-D24 or 7031-T24?

NO

- If the system diagnostics for the 7031-D24 or 7031-T24 are available, go to step 5.
- If the system diagnostics for the 7031-D24 or 7031-T24 are not available, but the stand-alone diagnostics are available, do the following:
 - a. Run the stand-alone diagnostics.
 - b. Go to step 6 on page 35.
- If neither the system diagnostics nor the standalone diagnostics are available, go to step 7 on page 35.

YES Go to Service request numbers.

5.

- a. Run the concurrent diagnostics to the 7031-D24 or 7031-T24. For information about how to run concurrent diagnostics, see Running the online and stand-alone diagnostics.

- b. When the concurrent diagnostics are complete, go to step 6.
6. **Did the diagnostics give you an SRN for the 7031-D24 or 7031-T24?**
- NO Go to step 7.
- YES Go to Service request numbers.
7. **Is the subsystem check LED flashing?**
- NO Go to step 8.
- YES A device is in Identify mode. A power supply, SCSI card, or disk drive module is to be added or installed.
8. **Is the subsystem check LED on continuously?**
- NO Go to step 12 on page 36.
- YES Go to step 9.
9. **Does the power-supply assembly have its FLT LED on because its DC On/Off switch is set to Off?**
- NO Go to step 10.
- YES
- Set the DC On/Off switch to On.
 - If you still have a problem, return to step 2 on page 34. Otherwise, go to “MAP 2410: Repair verification” on page 42 to verify the repair.
10. **Does any FRU have its Check or Fault LED on?**
- Note:** The check LED might be on any of the following parts:
- A SCSI interface card assembly (CARD FAULT LED)
 - A power-supply assembly (FLT LED)
 - A fan assembly (CHK LED)
 - A disk drive module (CHK LED)
- NO In the following sequence, exchange the following FRUs for new FRUs. Ensure that for *each* FRU exchange, you go to “MAP 2410: Repair verification” on page 42 to verify the repair.
- SCSI interface card assembly (go to the 5786, 5787, and 7031 models D24 and T24 removal and replacement procedures), and select the appropriate part.
 - Power supply (go to the 5786, 5787, and 7031 models D24 and T24 removal and replacement procedures), and select the appropriate part.
 - Fan assembly (go to the 5786, 5787, and 7031 models D24 and T24 removal and replacement procedures), and select the appropriate part.
 - Frame assembly (go to the 5786, 5787, and 7031 models D24 and T24 removal and replacement procedures), and select the appropriate part.
- YES
- If the FRU is a fan-and-power-supply assembly, go to step 11. Otherwise, exchange the FRU whose Check LED is on.
 - Go to “MAP 2410: Repair verification” on page 42 to verify the repair.
11. **Is the enclosure set up for remote power control (that is, is the power control switch of the SCSI interface card assembly set to Off)?**
- NO
- Exchange, for a new one, the power supply whose FLT LED is on (go to the 5786, 5787, and 7031 models D24 and T24 removal and replacement procedures), and select Power supply.

- b. Go to “MAP 2410: Repair verification” on page 42 to verify the repair.

YES

- a. Ensure that:
- The DC On/Off switch is set to On.
 - Both ends of the SCSI cable are correctly connected.
 - The host system is switched on.
- b. If the FLT LED of a power supply is still on, pull out the power supply to disconnect it from the 7031-D24 or 7031-T24, then push it back to reseat its connectors (go to the 5786, 5787, and 7031 models D24 and T24 removal and replacement procedures), and select the appropriate part.
- c. If the FLT LED is still on, exchange, in the sequence shown, the following FRUs for new FRUs. Ensure that for *each* FRU exchange, you go to “MAP 2410: Repair verification” on page 42 to verify the repair.
- 1) Power supply whose FLT LED is NOT on, (go to the 5786, 5787, and 7031 models D24 and T24 removal and replacement procedures), and select Power supply.
 - 2) SCSI interface card
 - 3) Frame assembly

12. Is the subsystem power LED on?

NO Go to “MAP 2020: 7031-D24 or 7031-T24 Power.”

YES Go to step 13.

13. Does either power supply assembly have its DC PWR LED off when it should be on?

NO Go to step 14.

YES

- a. Exchange the power-supply assembly whose LED is off.
- b. Go to “MAP 2410: Repair verification” on page 42 to verify the repair.

14. Are you here because access to all the SCSI devices that are in the 7031-D24 or 7031-T24 has been lost?

NO No problem has been found on the 7031-D24 or 7031-T24. For a final check, go to “MAP 2410: Repair verification” on page 42.

YES Go to “MAP 2340: 7031-D24 or 7031-T24 SCSI bus” on page 41.

MAP 2020: 7031-D24 or 7031-T24 Power

This MAP helps you to isolate FRUs that are causing a power problem on a 7031-D24 or 7031-T24. This MAP assumes that the disk subsystem is connected to a system that is powered on.

Attention: Do not remove power from the host system or the disk subsystem unless you are directed to in the following procedures. Power cables and external SCSI cables that connect the disk subsystem to the host system can be disconnected while that system is running.

1. You are here because the subsystem's power Light Emitting Diode (LED) is off.

Are the 2 middle green LEDs illuminated (AC and DC) on either power supply?

No Go to step 2.

Yes In the sequence shown, exchange the following FRUs for new FRUs. Ensure that for *each* FRU exchange, you go to “MAP 2410: Repair verification” on page 42 to verify the repair.

- a. Power supply (or power supplies if two are present)
- b. Frame assembly

2. Observe the power supply (or power supplies, if two are present).

Does at least one power supply have its AC PWR LED on?

No Go to step 3.

Yes Go to step 4.

3. Observe the power supplies.

Are the power supplies switched on?

No

a. Set the On/Off switch to On.

b. If the problem is still not solved, go to "MAP 2010: 7031-D24 or 7031-T24 START" on page 34.

Yes Go to step 4.

4. **Does either of the power supplies have its DC PWR LED on or flashing?**

No

a. Set the DC On/Off switch to Off, then to On again.

b. Go to step 5.

Yes In the sequence shown, exchange the following FRUs for new FRUs. Ensure that for *each* FRU exchange, you go to "MAP 2410: Repair verification" on page 42 to verify the repair.

a. Power supply (or power supplies if two are present)

b. Frame assembly

If the DC PWR LED is flashing, replace the SCSI interface card assembly. Go to 5.

5. **Does the power supply have its DC PWR LED on now?**

No Replace the power supply (or power supplies, if two are present).

Yes Go to 6.

6. **Is the subsystem power LED on continuously?**

No In the sequence shown, exchange the following FRUs for new FRUs. Ensure that for *each* FRU exchange, you go to "MAP 2410: Repair verification" on page 42 to verify the repair.

a. Fan assembly

b. SCSI interface card assembly

c. Frame assembly

Yes Go to step "MAP 2410: Repair verification" on page 42 to verify the repair.

7. (from step 6)

Observe the SCSI interface card assemblies.

Does either SCSI interface card have its TERM POWER[®] LED illuminated?

No Go to step 8.

Yes In the sequence shown, exchange the following FRUs for new FRUs. Ensure that for *each* FRU exchange, you go to "MAP 2410: Repair verification" on page 42 to verify the repair.

a. Power-supply (go to the 5786, 5787, and 7031 models D24 and T24 removal and replacement procedures),

b. Fan (go to the 5786, 5787, and 7031 models D24 and T24 removal and replacement procedures),

c. SCSI interface card assembly (go to the 5786, 5787, and 7031 models D24 and T24 removal and replacement procedures),

8. (from step 7)

Is the host system switched on?

- No** Switch on the host system (see the host system-service information). The 2104 Model DS4 or Model TS4 should switch on when the host system switches on.
- If the problem is still not solved, go to “MAP 2010: 7031-D24 or 7031-T24 START” on page 34.
- Yes** In the sequence shown, exchange the following FRUs for new FRUs. Ensure that for *each* FRU exchange, you go to “MAP 2410: Repair verification” on page 42 to verify the repair.
- a. External SCSI cables
 - b. SCSI interface card assembly (go to the 5786, 5787, and 7031 models D24 and T24 removal and replacement procedures),

Note: If the TERM POWER LED is still off, you might have a problem with the SCSI attachment that is in the host system (see the using system service information).

MAP 2022: 7031-D24 or 7031-T24 Power-on

This MAP helps you to isolate FRUs that are causing a power problem on a 7031-D24 or 7031-T24 disk subsystem.

Attention: Do not remove power from the host system or the disk subsystem unless you are directed to in the following procedures. Power cables and external SCSI cables that connect the disk subsystem to the host system can be disconnected while that system is running.

1. In this step you remove most of the FRUs from the 7031-D24 or 7031-T24 disk subsystem.
 - a. Remove both power supply assemblies, if two are present.
 - b. Remove the fan assemblies.
 - c. Remove the SCSI interface card assemblies. If your disk subsystem has only one SCSI interface card assembly, you do not need to remove the dummy assembly.
 - d. Disconnect all the disk drive modules from the backplane.

Note: You do not need to completely remove the disk drive modules.

 - e. Go to step 2.
2. Do the following procedure to check the disk subsystem as you reinstall parts.
 - a. Reinstall a power supply into position 1.
 - b. Reinstall the fan assemblies.
 - c. Connect a power cable to the power supply.
 - d. Set the DC On/Off switch of the power supply to On.
 - e. Reinstall one SCSI interface card and connect the appropriate cables to a powered-on system.

Note: Unless a procedure needs you to switch off the disk subsystem, leave it switched on for the remainder of this MAP.

Does the disk subsystem emit smoke or is there a burning smell?

No Go to step 3 on page 39.

Yes

- a. In the sequence shown, exchange the following FRUs for new FRUs. Ensure that for each FRU exchange, you go to “MAP 2410: Repair verification” on page 42 to verify the repair.
 - 1) Power supply that you just reinstalled
 - 2) Fan assemblies
 - 3) SCSI interface card
 - 4) Frame assembly
- b. Go to step 3 on page 39.

3. Reinstall the other power supply into position 2.
 - a. Connect a power cable to the power supply.
 - b. Set the DC On/Off switch of the power supply assembly to On.

Note: Unless a procedure needs you to switch off the disk subsystem, leave it switched on for the remainder of this MAP.

Does the disk subsystem emit smoke or is there a burning smell?

No Go to step 4.

Yes Replace the power supplies.

4. Reinstall a SCSI interface card assembly into position 1.

Does the disk subsystem emit smoke or is there a burning smell?

No If the disk subsystem has 2, 3, or 4 SCSI interface cards, go to step 5. Otherwise, go to step 6.

Yes

- a. Exchange, for a new one, the SCSI interface card assembly that you have just reinstalled.
- b. If the disk subsystem has two SCSI interface cards, go to step 5. Otherwise, go to step 6.

5. Reinstall the other SCSI interface card assembly into position 2.

Does the disk subsystem emit smoke or is there a burning smell?

No Go to step 6.

Yes

- a. Exchange, for a new one, the SCSI interface card assembly that you just reinstalled.
- b. Go to step 6.

6. Reconnect a disk drive.

Note: To engage the disk drive you must close its handle.

Does the disk subsystem emit smoke or is there a burning smell?

No Go to step 7.

Yes

- a. Exchange, for a new one, the disk drive module that you just reconnected.
- b. Go to step 7.

7. Reconnect the next disk drive module.

Note: To engage the disk drive you must close its handle.

Does the disk subsystem emit smoke or is there a burning smell?

No Go to step 8.

Yes

- a. Exchange, for a new one, the disk drive module that you just reconnected.
- b. Go to step 8.

8. Have you reconnected all the disk drive modules?

No Return to step 7.

Yes Go to step 9.

9. Have you solved the problem?

No Remove all power from the disk subsystem, and call for assistance.

Yes Go to step "MAP 2410: Repair verification" on page 42 to verify the repair.

MAP 2030: 7031-D24 or 7031-T24 power control

This MAP helps isolate FRUs that are causing a power problem that do not allow the 7031-D24 or 7031-T24 disk subsystem to power off when it should.

Attention: Do not remove power from the host system or the disk subsystem unless you are directed to in the following procedures. Power cables and external SCSI cables that connect the disk subsystem to the host system can be disconnected while that system is running.

You are here because power is still present at the disk subsystem although the host system is switched off.

1. Observe the cards.

Does the disk subsystem remain powered on for more than 30 seconds after the last connected system powers off?

No Go to "MAP 2410: Repair verification" on page 42 to verify the repair.

Yes Go to step 2.

2. Disconnect all SCSI cables and wait 30 seconds.

Is the disk subsystem still powered on?

No Go to step 3.

Yes Suspect an adapter problem in the host system.

3. Remove all SCSI initiator cards.

Is the disk subsystem still powered on?

No

- a. Replug the SCSI interface cards one at a time to determine which one is bad.
- b. If the disk subsystem powers on after replacing a SCSI interface card, replace that SCSI interface card.
- c. Go to "MAP 2410: Repair verification" on page 42 to verify the repair.

Yes Go to step 4.

4. **Does the disk subsystem have two power supplies?**

No

- a. In the sequence shown, exchange the following FRUs for new FRUs:
 - 1) Power supply assemblies
 - 2) Frame assembly
- b. Go to step 7 on page 41.

Yes Go to step 5.

5. **Do both power supplies have their DC PWR LEDs on?**

No Go to step 6.

Yes In the sequence shown, exchange the following FRUs for new FRUs. Ensure that for *each* FRU exchange, you go to "MAP 2410: Repair verification" on page 42 to verify the repair.

- a. Power supplies
- b. Frame assembly

6. **Does only one power supply have its DC PWR LED on?**

No Go to step 7 on page 41.

Yes

- a. Exchange, for a new one, the power supply whose DC PWR LED remains illuminated.
- b. Go to step 7.

7. Is the disk subsystem still powered on?

No The problem is solved.

Yes Call for assistance.

MAP 2340: 7031-D24 or 7031-T24 SCSI bus

You are here because the host system cannot access any SCSI device (disk drive module or enclosure services) in a 7031-D24 or 7031-T24 disk subsystem.

Attention: Do not remove power from the host system or the disk subsystem unless you are directed to in the following procedures. Power cables and external SCSI cables that connect the disk subsystem to the host system can be disconnected while that system is running.

1. Observe the SCSI Bus Split switch.

Is the disk subsystem powered on?

No Ensure that a SCSI cable is attached to a powered system, and the disk subsystem is powered on. Go to step 2.

Yes Go to step 2.

2. Is the yellow LED illuminated on the SCSI repeater card?

No Go to step 3.

Yes Replace the SCSI interface card. Go to step 3.

3. Is the green power LED illuminated on the SCSI repeater card?

No Go to "MAP 2020: 7031-D24 or 7031-T24 Power" on page 36.

Yes Go to step 4.

4. Is the SCSI interface card a dual SCSI interface card?

No Go to step 5.

Yes Disconnect one of the SCSI cables, go to step 5.

5. Note the positions of all the disk drive modules and the dummy disk drive modules so that you can reinstall the modules into their correct slots later.

a. Remove all of the disk drive modules.

b. Go to step 6.

6. Can the host system access enclosure services?

No In the sequence shown, exchange the following FRUs for new FRUs. Ensure that for each FRU exchange, you check whether you can access the disk drive module, to verify the repair.

a. External SCSI cable

b. SCSI interface card assembly

c. Frame assembly

d. Power supplies

e. If the repair is successful, reinstall all of the disk drive modules and cables that were removed in a previous steps.

f. Go to "MAP 2410: Repair verification" on page 42 to verify the repair.

Yes Go to step 7.

7. Reinsert the disk drive modules that you just removed, one at a time, checking for accessibility.

Can the host system access this disk drive module?

No

- a. In the sequence shown, exchange the following FRUs for new FRUs. Ensure that for *each* FRU exchange, you check whether you can access the disk drive module, to verify the repair.
 - 1) Exchange the disk drive module for a new one.
 - 2) External SCSI cable
 - 3) SCSI interface card assembly
 - 4) Power supply
 - 5) Frame assembly
- b. If the repair is successful, reinstall all the disk drive modules and if removed, the SCSI interface card assembly.
- c. Go to "MAP 2410: Repair verification" to verify the repair.

Yes Go to step 8.

8. Have you reinstalled all the disk drive modules?

No Go to step 7 on page 41

Yes Go to step 9.

9. (from step 8)

Can the host system get access to all of the plugged disk drive module and enclosure services?

No Call your support center for assistance.

- a. Exchange the disk drive module for a new one.
- b. Return to step 8.

Yes Go to "MAP 2410: Repair verification" to verify the repair.

MAP 2410: Repair verification

Verify a repair after a FRU is exchanged on the enclosure.

Attention: Do not remove power from the host server or the I/O enclosure unless you are directed to in the following procedures. Power cables and external SCSI cables that connect the I/O enclosure to the host server can be disconnected while that server is running.

1. Ensure that the DC On/Off switch of each power supply assembly is set to On.

Are all Check LEDs off?

No Go to "MAP 2010: 7031-D24 or 7031-T24 START" on page 34.

Yes Go to step 2.

2. Can the host system access all SCSI devices?

No Go to "MAP 2010: 7031-D24 or 7031-T24 START" on page 34.

Yes The repair is complete, go to <http://publib.boulder.ibm.com/infocenter/systems/scope/hw/topic/p7ect/arecloseofcall.htm>. **This completes the procedure.**

Note: For system level repair verification, go to "Verify a repair" located in the host server's service information.

Notices

This information was developed for products and services offered in the U.S.A.

The manufacturer may not offer the products, services, or features discussed in this document in other countries. Consult the manufacturer's representative for information on the products and services currently available in your area. Any reference to the manufacturer's product, program, or service is not intended to state or imply that only that product, program, or service may be used. Any functionally equivalent product, program, or service that does not infringe any intellectual property right of the manufacturer may be used instead. However, it is the user's responsibility to evaluate and verify the operation of any product, program, or service.

The manufacturer may have patents or pending patent applications covering subject matter described in this document. The furnishing of this document does not grant you any license to these patents. You can send license inquiries, in writing, to the manufacturer.

The following paragraph does not apply to the United Kingdom or any other country where such provisions are inconsistent with local law: THIS INFORMATION IS PROVIDED "AS IS" WITHOUT WARRANTY OF ANY KIND, EITHER EXPRESS OR IMPLIED, INCLUDING, BUT NOT LIMITED TO, THE IMPLIED WARRANTIES OF NON-INFRINGEMENT, MERCHANTABILITY OR FITNESS FOR A PARTICULAR PURPOSE. Some states do not allow disclaimer of express or implied warranties in certain transactions, therefore, this statement may not apply to you.

This information could include technical inaccuracies or typographical errors. Changes are periodically made to the information herein; these changes will be incorporated in new editions of the publication. The manufacturer may make improvements and/or changes in the product(s) and/or the program(s) described in this publication at any time without notice.

Any references in this information to websites not owned by the manufacturer are provided for convenience only and do not in any manner serve as an endorsement of those websites. The materials at those websites are not part of the materials for this product and use of those websites is at your own risk.

The manufacturer may use or distribute any of the information you supply in any way it believes appropriate without incurring any obligation to you.

Any performance data contained herein was determined in a controlled environment. Therefore, the results obtained in other operating environments may vary significantly. Some measurements may have been made on development-level systems and there is no guarantee that these measurements will be the same on generally available systems. Furthermore, some measurements may have been estimated through extrapolation. Actual results may vary. Users of this document should verify the applicable data for their specific environment.

Information concerning products not produced by this manufacturer was obtained from the suppliers of those products, their published announcements or other publicly available sources. This manufacturer has not tested those products and cannot confirm the accuracy of performance, compatibility or any other claims related to products not produced by this manufacturer. Questions on the capabilities of products not produced by this manufacturer should be addressed to the suppliers of those products.

All statements regarding the manufacturer's future direction or intent are subject to change or withdrawal without notice, and represent goals and objectives only.

The manufacturer's prices shown are the manufacturer's suggested retail prices, are current and are subject to change without notice. Dealer prices may vary.

This information is for planning purposes only. The information herein is subject to change before the products described become available.

This information contains examples of data and reports used in daily business operations. To illustrate them as completely as possible, the examples include the names of individuals, companies, brands, and products. All of these names are fictitious and any similarity to the names and addresses used by an actual business enterprise is entirely coincidental.

If you are viewing this information in softcopy, the photographs and color illustrations may not appear.

The drawings and specifications contained herein shall not be reproduced in whole or in part without the written permission of the manufacturer.

The manufacturer has prepared this information for use with the specific machines indicated. The manufacturer makes no representations that it is suitable for any other purpose.

The manufacturer's computer systems contain mechanisms designed to reduce the possibility of undetected data corruption or loss. This risk, however, cannot be eliminated. Users who experience unplanned outages, system failures, power fluctuations or outages, or component failures must verify the accuracy of operations performed and data saved or transmitted by the system at or near the time of the outage or failure. In addition, users must establish procedures to ensure that there is independent data verification before relying on such data in sensitive or critical operations. Users should periodically check the manufacturer's support websites for updated information and fixes applicable to the system and related software.

Ethernet connection usage restriction

This product is not intended to be connected directly or indirectly by any means whatsoever to interfaces of public telecommunications networks.

Trademarks

IBM, the IBM logo, and ibm.com are trademarks or registered trademarks of International Business Machines Corp., registered in many jurisdictions worldwide. Other product and service names might be trademarks of IBM or other companies. A current list of IBM trademarks is available on the Web at Copyright and trademark information at www.ibm.com/legal/copytrade.shtml.

Linux is a registered trademark of Linus Torvalds in the United States, other countries, or both.

Other product or service names might be trademarks of IBM or other companies.

Electronic emission notices

Class A Notices

The following Class A statements apply to the IBM servers that contain the POWER7[®] processor and its features unless designated as electromagnetic compatibility (EMC) Class B in the feature information.

Federal Communications Commission (FCC) statement

Note: This equipment has been tested and found to comply with the limits for a Class A digital device, pursuant to Part 15 of the FCC Rules. These limits are designed to provide reasonable protection against harmful interference when the equipment is operated in a commercial environment. This equipment generates, uses, and can radiate radio frequency energy and, if not installed and used in accordance with the instruction manual, may cause harmful interference to radio communications. Operation of this

equipment in a residential area is likely to cause harmful interference, in which case the user will be required to correct the interference at his own expense.

Properly shielded and grounded cables and connectors must be used in order to meet FCC emission limits. IBM is not responsible for any radio or television interference caused by using other than recommended cables and connectors or by unauthorized changes or modifications to this equipment. Unauthorized changes or modifications could void the user's authority to operate the equipment.

This device complies with Part 15 of the FCC rules. Operation is subject to the following two conditions: (1) this device may not cause harmful interference, and (2) this device must accept any interference received, including interference that may cause undesired operation.

Industry Canada Compliance Statement

This Class A digital apparatus complies with Canadian ICES-003.

Avis de conformité à la réglementation d'Industrie Canada

Cet appareil numérique de la classe A est conforme à la norme NMB-003 du Canada.

European Community Compliance Statement

This product is in conformity with the protection requirements of EU Council Directive 2004/108/EC on the approximation of the laws of the Member States relating to electromagnetic compatibility. IBM cannot accept responsibility for any failure to satisfy the protection requirements resulting from a non-recommended modification of the product, including the fitting of non-IBM option cards.

This product has been tested and found to comply with the limits for Class A Information Technology Equipment according to European Standard EN 55022. The limits for Class A equipment were derived for commercial and industrial environments to provide reasonable protection against interference with licensed communication equipment.

European Community contact:
IBM Deutschland GmbH
Technical Regulations, Department M456
IBM-Allee 1, 71139 Ehningen, Germany
Tele: +49 7032 15-2937
email: tjahn@de.ibm.com

Warning: This is a Class A product. In a domestic environment, this product may cause radio interference, in which case the user may be required to take adequate measures.

VCCI Statement - Japan

この装置は、クラスA 情報技術装置です。この装置を家庭環境で使用すると電波妨害を引き起こすことがあります。この場合には使用者が適切な対策を講ずるよう要求されることがあります。

VCCI-A

The following is a summary of the VCCI Japanese statement in the box above:

This is a Class A product based on the standard of the VCCI Council. If this equipment is used in a domestic environment, radio interference may occur, in which case, the user may be required to take corrective actions.

**Japanese Electronics and Information Technology Industries Association (JEITA)
Confirmed Harmonics Guideline (products less than or equal to 20 A per phase)**

高調波ガイドライン適合品

**Japanese Electronics and Information Technology Industries Association (JEITA)
Confirmed Harmonics Guideline with Modifications (products greater than 20 A per phase)**

高調波ガイドライン準用品

Electromagnetic Interference (EMI) Statement - People's Republic of China

声 明

此为 A 级产品,在生活环境中,
该产品可能会造成无线电干扰。
在这种情况下,可能需要用户对其
干扰采取切实可行的措施。

Declaration: This is a Class A product. In a domestic environment this product may cause radio interference in which case the user may need to perform practical action.

Electromagnetic Interference (EMI) Statement - Taiwan

警告使用者：

這是甲類的資訊產品，在
居住的環境中使用時，可
能會造成射頻干擾，在這
種情況下，使用者會被要
求採取某些適當的對策。

The following is a summary of the EMI Taiwan statement above.

Warning: This is a Class A product. In a domestic environment this product may cause radio interference in which case the user will be required to take adequate measures.

IBM Taiwan Contact Information:

台灣IBM 產品服務聯絡方式：
台灣國際商業機器股份有限公司
台北市松仁路7號3樓
電話：0800-016-888

Electromagnetic Interference (EMI) Statement - Korea

이 기기는 업무용으로 전자파적합등록을 한 기기이오니 판매자 또는 사용자는 이점을 주의하시기 바라며, 만약 잘못 판매 또는 구입하였을 때에는 가정용으로 교환하시기 바랍니다.

Please note that this equipment has obtained EMC registration for commercial use. In the event that it has been mistakenly sold or purchased, please exchange it for equipment certified for home use.

Germany Compliance Statement

Deutschsprachiger EU Hinweis: Hinweis für Geräte der Klasse A EU-Richtlinie zur Elektromagnetischen Verträglichkeit

Dieses Produkt entspricht den Schutzanforderungen der EU-Richtlinie 2004/108/EG zur Angleichung der Rechtsvorschriften über die elektromagnetische Verträglichkeit in den EU-Mitgliedsstaaten und hält die Grenzwerte der EN 55022 Klasse A ein.

Um dieses sicherzustellen, sind die Geräte wie in den Handbüchern beschrieben zu installieren und zu betreiben. Des Weiteren dürfen auch nur von der IBM empfohlene Kabel angeschlossen werden. IBM übernimmt keine Verantwortung für die Einhaltung der Schutzanforderungen, wenn das Produkt ohne Zustimmung von IBM verändert bzw. wenn Erweiterungskomponenten von Fremdherstellern ohne Empfehlung von IBM gesteckt/eingebaut werden.

EN 55022 Klasse A Geräte müssen mit folgendem Warnhinweis versehen werden:

"Warnung: Dieses ist eine Einrichtung der Klasse A. Diese Einrichtung kann im Wohnbereich Funk-Störungen verursachen; in diesem Fall kann vom Betreiber verlangt werden, angemessene Maßnahmen zu ergreifen und dafür aufzukommen."

Deutschland: Einhaltung des Gesetzes über die elektromagnetische Verträglichkeit von Geräten

Dieses Produkt entspricht dem "Gesetz über die elektromagnetische Verträglichkeit von Geräten (EMVG)". Dies ist die Umsetzung der EU-Richtlinie 2004/108/EG in der Bundesrepublik Deutschland.

Zulassungsbescheinigung laut dem Deutschen Gesetz über die elektromagnetische Verträglichkeit von Geräten (EMVG) (bzw. der EMC EG Richtlinie 2004/108/EG) für Geräte der Klasse A

Dieses Gerät ist berechtigt, in Übereinstimmung mit dem Deutschen EMVG das EG-Konformitätszeichen - CE - zu führen.

Verantwortlich für die Einhaltung der EMV Vorschriften ist der Hersteller:
International Business Machines Corp.

New Orchard Road
Armonk, New York 10504
Tel: 914-499-1900

Der verantwortliche Ansprechpartner des Herstellers in der EU ist:
IBM Deutschland GmbH
Technical Regulations, Abteilung M456
IBM-Allee 1, 71139 Ehningen, Germany
Tel: +49 7032 15-2937
email: tjahn@de.ibm.com

Generelle Informationen:

Das Gerät erfüllt die Schutzanforderungen nach EN 55024 und EN 55022 Klasse A.

Electromagnetic Interference (EMI) Statement - Russia

**ВНИМАНИЕ! Настоящее изделие относится к классу А.
В жилых помещениях оно может создавать
радиопомехи, для снижения которых необходимы
дополнительные меры**

Terms and conditions

Permissions for the use of these publications is granted subject to the following terms and conditions.

Personal Use: You may reproduce these publications for your personal, noncommercial use provided that all proprietary notices are preserved. You may not distribute, display or make derivative works of these publications, or any portion thereof, without the express consent of the manufacturer.

Commercial Use: You may reproduce, distribute and display these publications solely within your enterprise provided that all proprietary notices are preserved. You may not make derivative works of these publications, or reproduce, distribute or display these publications or any portion thereof outside your enterprise, without the express consent of the manufacturer.

Except as expressly granted in this permission, no other permissions, licenses or rights are granted, either express or implied, to the publications or any information, data, software or other intellectual property contained therein.

The manufacturer reserves the right to withdraw the permissions granted herein whenever, in its discretion, the use of the publications is detrimental to its interest or, as determined by the manufacturer, the above instructions are not being properly followed.

You may not download, export or re-export this information except in full compliance with all applicable laws and regulations, including all United States export laws and regulations.

THE MANUFACTURER MAKES NO GUARANTEE ABOUT THE CONTENT OF THESE PUBLICATIONS. THESE PUBLICATIONS ARE PROVIDED "AS-IS" AND WITHOUT WARRANTY OF ANY KIND, EITHER EXPRESSED OR IMPLIED, INCLUDING BUT NOT LIMITED TO IMPLIED WARRANTIES OF MERCHANTABILITY, NON-INFRINGEMENT, AND FITNESS FOR A PARTICULAR PURPOSE.