

5802 and 5877 removal and replacement procedures□□



ESCALA Power7

5802 and 5877 removal and replacement procedures□□

This publication concerns the following models:

- Bull Escala E5-700 (Power 750 / 8233-E8B)
- Bull Escala M6-700 (Power 770 / 9117-MMB)
- Bull Escala M7-700 (Power 780 / 9179-MHB)
- Bull Escala E1-700 (Power 710 / 8231-E2B)
- Bull Escala E2-700 / E2-700T (Power 720 / 8202-E4B)
- Bull Escala E3-700 (Power 730 / 8231-E2B)
- Bull Escala E4-700 / E4-700T (Power 740 / 8205-E6B)

References to Power 755 / 8236-E8C models are irrelevant.

Hardware

May 2011

BULL CEDOC
357 AVENUE PATTON
B.P.20845
49008 ANGERS CEDEX 01
FRANCE

REFERENCE
86 A1 62FF 03

The following copyright notice protects this book under Copyright laws which prohibit such actions as, but not limited to, copying, distributing, modifying, and making derivative works.

Copyright © Bull SAS 2007-2011

Printed in France

Suggestions and criticisms concerning the form, content, and presentation of this book are invited. A form is provided at the end of this book for this purpose.

To order additional copies of this book or other Bull Technical Publications, you are invited to use the Ordering Form also provided at the end of this book.

Trademarks and Acknowledgements

We acknowledge the right of proprietors of trademarks mentioned in this book.

The information in this document is subject to change without notice. Bull will not be liable for errors contained herein, or for incidental or consequential damages in connection with the use of this material.

Contents

Safety notices	v
Removal and replacement procedures	1
What's new in 5802 and 5877 removal and replacement procedures	1
HMC-based procedures	1
Non-HMC-based procedures	1
Backplane (CRU)	1
Removing the backplane	1
Replacing the backplane	5
Disk drive (CRU)	10
Enclosure management controller (CRU)	10
Removing the enclosure management controller card	10
Replacing the enclosure management controller card	12
I/O planar (CRU)	13
Removing the I/O planar	13
Replacing the I/O planar	15
Servicing the Midplane (FRU)	16
Removing the Midplane	16
Replacing the Midplane	26
PCI adapters	33
Preparing to install, remove, or replace a PCI adapter cassette	34
Installing a PCI adapter contained in a cassette	34
Installing a PCI adapter cassette with the power off	34
Installing a PCI adapter cassette	35
Installing a PCI adapter contained in a cassette with the power on in the AIX environment	36
Installing a PCI adapter contained in a cassette with the power on in the IBM i environment	37
Installing a PCI adapter contained in a cassette with the power on in the Linux environment	37
Removing a PCI adapter contained in a cassette from the expansion unit	38
Removing a PCI adapter contained in a cassette from the expansion unit with the system power off	38
Removing a PCI adapter cassette from the expansion unit	39
Removing a PCI adapter contained in a cassette from the expansion unit with the power on in AIX	40
Removing a PCI adapter contained in a cassette from the expansion unit with the power on in IBM i	41
Removing a PCI adapter contained in a cassette from the expansion unit with the power on in Linux	42
Replacing a PCI adapter contained in a cassette from the expansion unit with the power off	42
Replacing a PCI adapter contained in a cassette from the expansion unit with the power on in AIX	43
Replacing a PCI adapter contained in a cassette from the expansion unit with the power on in IBM i	45
Replacing a PCI adapter contained in a cassette from the expansion unit with the power on in Linux	45
PCI adapter single-width and double-width cassettes	46
Removing an adapter from the PCI adapter single-width cassette	46
Placing a PCI adapter in a single-width cassette	48
Removing an adapter from the PCI adapter double-wide cassette	55
Placing an adapter in the PCI adapter double-wide cassette	58
Related procedures for installing and removing PCI adapters	63
Before you begin	63
Avoiding electric shock	66
Handling static-sensitive devices	67
PCI hot-plug manager access for AIX	68
Prerequisites for hot-plugging PCI adapters in Linux	69
Verifying that the hot-plug PCI tools are installed for Linux	70
Component LEDs	71
Power supply and fan (CRU)	71
Removing a power supply or fan with power on	71
Replacing a power supply or fan with power on	75
SAS conduit card (FRU)	79
Removing a SAS conduit card from a 5802 expansion unit with power off	80

Replacing a SAS conduit card in a 5802 expansion unit with power off	90
SAS expander card (CRU)	96
Removing a SAS expander card with power off	97
Replacing a SAS expander card with power off	97
Common procedures	98
Before you begin	98
Identifying a part	101
Identifying a failing part in an AIX system or logical partition	101
Locating a failing part in an AIX system or logical partition	101
Activating the indicator light for the failing part.	102
Deactivating the failing-part indicator light	102
Identifying a failing part in an IBM i system or logical partition	102
Activating the failing-part indicator light	102
Deactivating the failing-part indicator light	103
Identifying a failing part in a Linux system or logical partition	104
Locating a failing part in a Linux system or logical partition	104
Finding the location code of a failing part in a Linux system or logical partition	104
Activating the indicator light for the failing part.	104
Deactivating the failing-part indicator light	104
Locating a failing part in a Virtual I/O Server system or logical partition	105
Identifying a part by using the Virtual I/O Server	105
Starting the system or logical partition	105
Starting a system that is not managed by an HMC or an SDMC	105
Starting a system or logical partition by using the Hardware Management Console	107
Stopping a system or logical partition	107
Stopping a system that is not managed by an HMC or an SDMC	107
Stopping a system by using the Hardware Management Console	108
Installing a feature by using the Hardware Management Console	109
Removing a part by using the Hardware Management Console	109
Replacing a part by using the Hardware Management Console	110
Removing a part by using the Hardware Management Console.	110
Replacing a part by using the Hardware Management Console	111
Verifying the installed part	111
Verifying an installed feature or replaced part in an AIX system or logical partition	111
Verifying the installed part in an IBM i system or logical partition.	114
Deactivating the failing-part indicator light	114
Verifying the installed part in a Linux system or logical partition	115
Verifying an installed part by using stand-alone diagnostics	115
Verifying the installed part by using Hardware Management Console	117
Activating and deactivating LEDs by using the HMC	117
Viewing serviceable events by using the HMC	118
Verifying an installed feature or replaced part on a system or logical partition by using Virtual I/O Server tools	119
Notices	123
Trademarks	124
Electronic emission notices	124
Class A Notices.	124
Terms and conditions.	128

Safety notices

Safety notices may be printed throughout this guide:

- **DANGER** notices call attention to a situation that is potentially lethal or extremely hazardous to people.
- **CAUTION** notices call attention to a situation that is potentially hazardous to people because of some existing condition.
- **Attention** notices call attention to the possibility of damage to a program, device, system, or data.

World Trade safety information

Several countries require the safety information contained in product publications to be presented in their national languages. If this requirement applies to your country, a safety information booklet is included in the publications package shipped with the product. The booklet contains the safety information in your national language with references to the U.S. English source. Before using a U.S. English publication to install, operate, or service this product, you must first become familiar with the related safety information in the booklet. You should also refer to the booklet any time you do not clearly understand any safety information in the U.S. English publications.

German safety information

Das Produkt ist nicht für den Einsatz an Bildschirmarbeitsplätzen im Sinne § 2 der Bildschirmarbeitsverordnung geeignet.

Laser safety information

IBM® servers can use I/O cards or features that are fiber-optic based and that utilize lasers or LEDs.

Laser compliance

IBM servers may be installed inside or outside of an IT equipment rack.

DANGER

When working on or around the system, observe the following precautions:

Electrical voltage and current from power, telephone, and communication cables are hazardous. To avoid a shock hazard:

- Connect power to this unit only with the IBM provided power cord. Do not use the IBM provided power cord for any other product.
- Do not open or service any power supply assembly.
- Do not connect or disconnect any cables or perform installation, maintenance, or reconfiguration of this product during an electrical storm.
- The product might be equipped with multiple power cords. To remove all hazardous voltages, disconnect all power cords.
- Connect all power cords to a properly wired and grounded electrical outlet. Ensure that the outlet supplies proper voltage and phase rotation according to the system rating plate.
- Connect any equipment that will be attached to this product to properly wired outlets.
- When possible, use one hand only to connect or disconnect signal cables.
- Never turn on any equipment when there is evidence of fire, water, or structural damage.
- Disconnect the attached power cords, telecommunications systems, networks, and modems before you open the device covers, unless instructed otherwise in the installation and configuration procedures.
- Connect and disconnect cables as described in the following procedures when installing, moving, or opening covers on this product or attached devices.

To Disconnect:

1. Turn off everything (unless instructed otherwise).
2. Remove the power cords from the outlets.
3. Remove the signal cables from the connectors.
4. Remove all cables from the devices

To Connect:

1. Turn off everything (unless instructed otherwise).
2. Attach all cables to the devices.
3. Attach the signal cables to the connectors.
4. Attach the power cords to the outlets.
5. Turn on the devices.

(D005)

DANGER

Observe the following precautions when working on or around your IT rack system:

- Heavy equipment—personal injury or equipment damage might result if mishandled.
- Always lower the leveling pads on the rack cabinet.
- Always install stabilizer brackets on the rack cabinet.
- To avoid hazardous conditions due to uneven mechanical loading, always install the heaviest devices in the bottom of the rack cabinet. Always install servers and optional devices starting from the bottom of the rack cabinet.
- Rack-mounted devices are not to be used as shelves or work spaces. Do not place objects on top of rack-mounted devices.



- Each rack cabinet might have more than one power cord. Be sure to disconnect all power cords in the rack cabinet when directed to disconnect power during servicing.
- Connect all devices installed in a rack cabinet to power devices installed in the same rack cabinet. Do not plug a power cord from a device installed in one rack cabinet into a power device installed in a different rack cabinet.
- An electrical outlet that is not correctly wired could place hazardous voltage on the metal parts of the system or the devices that attach to the system. It is the responsibility of the customer to ensure that the outlet is correctly wired and grounded to prevent an electrical shock.

CAUTION

- Do not install a unit in a rack where the internal rack ambient temperatures will exceed the manufacturer's recommended ambient temperature for all your rack-mounted devices.
- Do not install a unit in a rack where the air flow is compromised. Ensure that air flow is not blocked or reduced on any side, front, or back of a unit used for air flow through the unit.
- Consideration should be given to the connection of the equipment to the supply circuit so that overloading of the circuits does not compromise the supply wiring or overcurrent protection. To provide the correct power connection to a rack, refer to the rating labels located on the equipment in the rack to determine the total power requirement of the supply circuit.
- *(For sliding drawers.)* Do not pull out or install any drawer or feature if the rack stabilizer brackets are not attached to the rack. Do not pull out more than one drawer at a time. The rack might become unstable if you pull out more than one drawer at a time.
- *(For fixed drawers.)* This drawer is a fixed drawer and must not be moved for servicing unless specified by the manufacturer. Attempting to move the drawer partially or completely out of the rack might cause the rack to become unstable or cause the drawer to fall out of the rack.

(R001)

CAUTION:

Removing components from the upper positions in the rack cabinet improves rack stability during relocation. Follow these general guidelines whenever you relocate a populated rack cabinet within a room or building:

- Reduce the weight of the rack cabinet by removing equipment starting at the top of the rack cabinet. When possible, restore the rack cabinet to the configuration of the rack cabinet as you received it. If this configuration is not known, you must observe the following precautions:
 - Remove all devices in the 32U position and above.
 - Ensure that the heaviest devices are installed in the bottom of the rack cabinet.
 - Ensure that there are no empty U-levels between devices installed in the rack cabinet below the 32U level.
- If the rack cabinet you are relocating is part of a suite of rack cabinets, detach the rack cabinet from the suite.
- Inspect the route that you plan to take to eliminate potential hazards.
- Verify that the route that you choose can support the weight of the loaded rack cabinet. Refer to the documentation that comes with your rack cabinet for the weight of a loaded rack cabinet.
- Verify that all door openings are at least 760 x 230 mm (30 x 80 in.).
- Ensure that all devices, shelves, drawers, doors, and cables are secure.
- Ensure that the four leveling pads are raised to their highest position.
- Ensure that there is no stabilizer bracket installed on the rack cabinet during movement.
- Do not use a ramp inclined at more than 10 degrees.
- When the rack cabinet is in the new location, complete the following steps:
 - Lower the four leveling pads.
 - Install stabilizer brackets on the rack cabinet.
 - If you removed any devices from the rack cabinet, repopulate the rack cabinet from the lowest position to the highest position.
- If a long-distance relocation is required, restore the rack cabinet to the configuration of the rack cabinet as you received it. Pack the rack cabinet in the original packaging material, or equivalent. Also lower the leveling pads to raise the casters off of the pallet and bolt the rack cabinet to the pallet.

(R002)

(L001)



(L002)

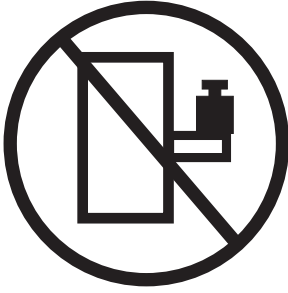

(L003)

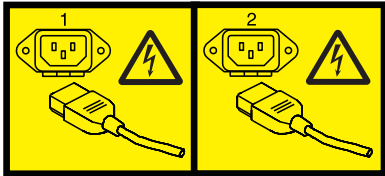

or



All lasers are certified in the U.S. to conform to the requirements of DHHS 21 CFR Subchapter J for class 1 laser products. Outside the U.S., they are certified to be in compliance with IEC 60825 as a class 1 laser product. Consult the label on each part for laser certification numbers and approval information.

CAUTION:

This product might contain one or more of the following devices: CD-ROM drive, DVD-ROM drive, DVD-RAM drive, or laser module, which are Class 1 laser products. Note the following information:

- Do not remove the covers. Removing the covers of the laser product could result in exposure to hazardous laser radiation. There are no serviceable parts inside the device.
- Use of the controls or adjustments or performance of procedures other than those specified herein might result in hazardous radiation exposure.

(C026)

CAUTION:

Data processing environments can contain equipment transmitting on system links with laser modules that operate at greater than Class 1 power levels. For this reason, never look into the end of an optical fiber cable or open receptacle. (C027)

CAUTION:

This product contains a Class 1M laser. Do not view directly with optical instruments. (C028)

CAUTION:

Some laser products contain an embedded Class 3A or Class 3B laser diode. Note the following information: laser radiation when open. Do not stare into the beam, do not view directly with optical instruments, and avoid direct exposure to the beam. (C030)

Power and cabling information for NEBS (Network Equipment-Building System) GR-1089-CORE

The following comments apply to the IBM servers that have been designated as conforming to NEBS (Network Equipment-Building System) GR-1089-CORE:

The equipment is suitable for installation in the following:

- Network telecommunications facilities
- Locations where the NEC (National Electrical Code) applies

The intrabuilding ports of this equipment are suitable for connection to intrabuilding or unexposed wiring or cabling only. The intrabuilding ports of this equipment *must not* be metallically connected to the interfaces that connect to the OSP (outside plant) or its wiring. These interfaces are designed for use as intrabuilding interfaces only (Type 2 or Type 4 ports as described in GR-1089-CORE) and require isolation from the exposed OSP cabling. The addition of primary protectors is not sufficient protection to connect these interfaces metallically to OSP wiring.

Note: All Ethernet cables must be shielded and grounded at both ends.

The ac-powered system does not require the use of an external surge protection device (SPD).

The dc-powered system employs an isolated DC return (DC-I) design. The DC battery return terminal *shall not* be connected to the chassis or frame ground.

Removal and replacement procedures

This topic collection contains instructions for removing and replacing parts, verifying the repair, and closing a service call.

Both HMC and non HMC removal and replacement procedures are provided.

- If the expansion unit has an HMC, see “HMC-based procedures.”
- If the expansion unit does not have an HMC, see “Non-HMC-based procedures.”

What's new in 5802 and 5877 removal and replacement procedures

Read about new or significantly changed information in 5802 and 5877 removal and replacement procedures since the previous update of this topic collection.

February 2010

- Added information for IBM Power Systems™ servers that contain the POWER7® processor.

HMC-based procedures

Use the Service Focal Point application on the Hardware Management Console (HMC) to find information about how to remove and replace parts.

Follow these procedures to access the Service Focal Point application:

1. Log into the HMC as the service representative.
2. In the navigation area, select **Servers** from the **Systems Management** navigation.
3. Select the server that requires a parts exchange.
4. Select **Serviceability**, then **Hardware**, and then **Exchange FRU**.
5. The **Exchange FRU** window opens. Select the FRU to exchange, next click on **Launch Procedure**, and follow the instructions.

Non-HMC-based procedures

Use the removal and replacement procedures when you repair, maintain, or exchange your system parts.

The removal and replacement procedures are divided into field replaceable units (FRUs) and customer replaceable units (CRUs). CRUs can be removed and replaced by customers, but FRUs can only be removed and replaced by an IBM authorized service representative.

Use the following procedures after the server has identified a failing part. The server information details how to activate and deactivate LEDs. After the part or parts are replaced, refer to the server's documentation to verify the repair, and close the service call.

Backplane (CRU)

Use this procedure to install and remove the backplane.

Removing the backplane

If your system is managed by the IBM Systems Director Management Console (SDMC), use the SDMC to complete the steps for removing the disk drive backplane from the server. For instructions, see Removing a part using the Systems Director Management Console.

If your system is managed by the Hardware Management Console (HMC), use the HMC to complete the steps for removing the disk drive backplane from the server. For information about using the HMC to remove the disk drive backplane, see Removing a part using the Hardware Management Console.

If you do not have an HMC or SDMC, complete the following steps to remove the disk drive backplane:

1. Identify the system that you will be working on by using the identify the system process to turn on the system locate (blue) indicator. For more information, see Control panel LEDs.
2. Complete the prerequisite tasks as described in Before you begin.
3. Do one of the following steps, as applicable:
 - a. If you are removing the disk drive backplane for a system upgrade or as part of another procedure, continue to step 3.
 - b. If you are removing the disk drive backplane because of a system failure, use the service action log to help identify the failing part. See Identifying a failing part.
4. Stop the system or logical partition. For instructions, see Stopping a system or logical partition.
5. Disconnect the power from the 5802 expansion unit by unplugging the system.

Note: This system has a second power supply. Before continuing with this procedure, ensure that the power source to the system has been completely disconnected.

(L003)

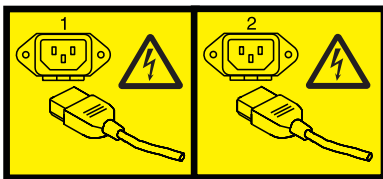

or



6. Open the front rack door.
7. Use the service indicator light-emitting diodes (LEDs) to help identify the part, as described in Identifying a part.
8. Remove the disk drives and fillers from the disk drive backplane in the 5802 expansion unit as shown in Figure 1 on page 3.

Note: Record the location of each disk drive you remove so that the disk drive can be replaced in the same location again.

- a. Squeeze the latch of the disk drive and pull the handle **(A)** toward you to release the drives.
- b. Supporting the bottom of the disk drive with your hand, slide it out of the disk drive backplane.

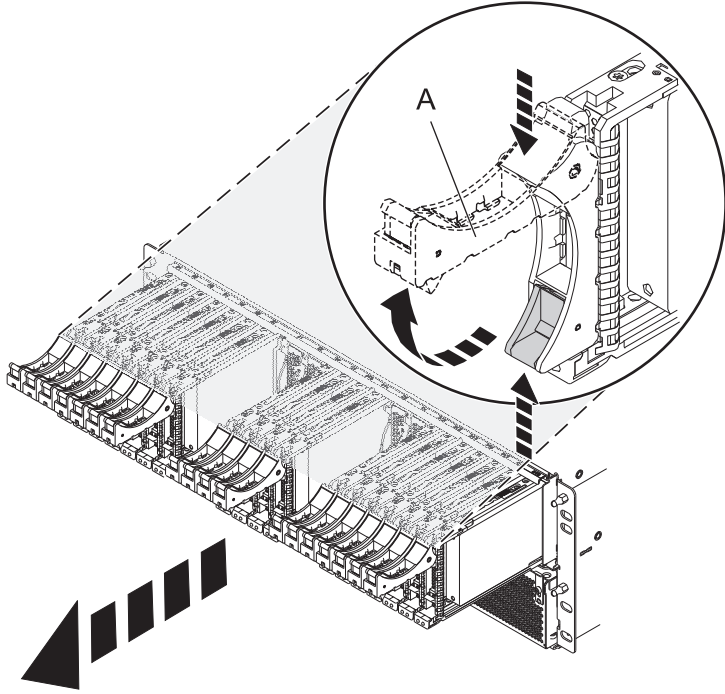

Figure 1. Removing the disk drives from the disk drive backplane

9. Remove the port cards and fillers from the disk drive backplane in the 5802 expansion unit as shown in Figure 2 on page 4.
 - a. Grasp the end of the latch **(A)** and pull it upward to unlock the port card.
 - b. Using your hand to support the bottom of the port card, slide it out of the disk drive backplane.
 - c. Place the port card on an electrostatic discharge (ESD) surface.

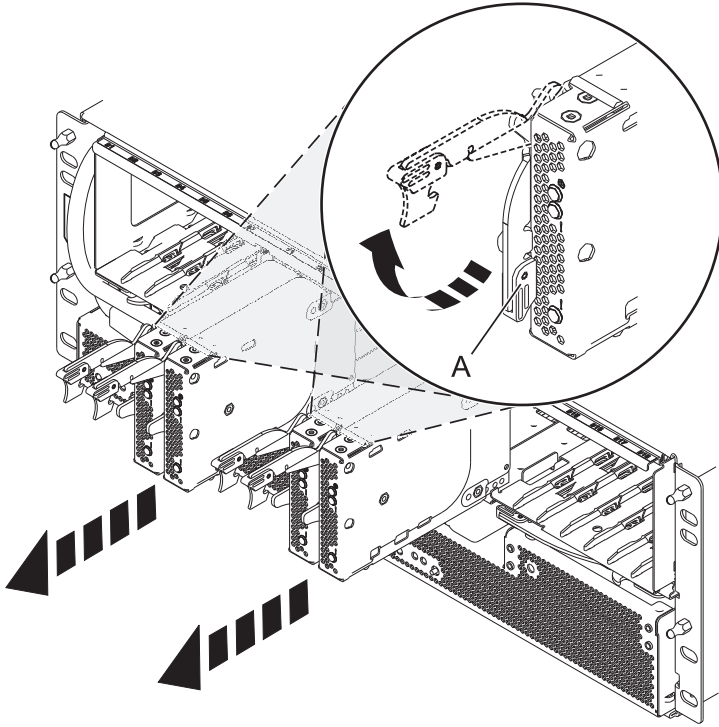

Figure 2. Removing the port card from the disk drive backplane

10. Remove the disk drive backplane from the 5802 expansion unit as shown in Figure 3 on page 5, or remove the backplane filler from the 5877 expansion unit as shown in Figure 4 on page 5.

CAUTION:

The disk drive backplane in the 5802 expansion unit might be heavy. Ensure that you can safely complete the procedure.

- a. Squeeze the blue latches (A) to unlock the handles.
- b. Pull the handles (B) outward in the direction shown to release the disk drive backplane.
- c. Slide the disk drive backplane out of the enclosure, using your hand to support the bottom of the disk drive backplane.

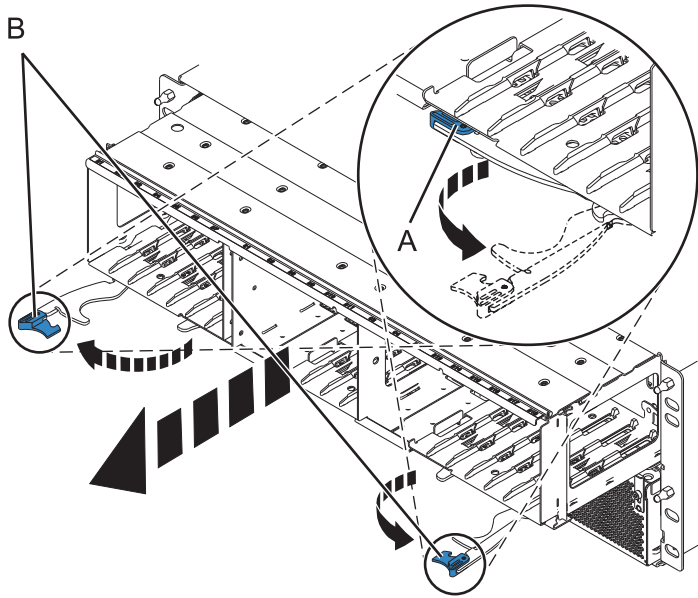

Figure 3. Removing the disk drive backplane from the enclosure

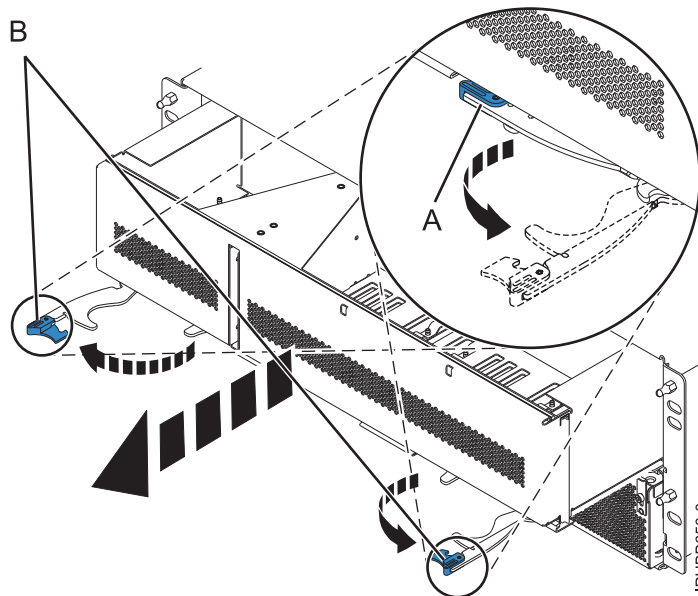

Figure 4. Removing the backplane filler from the enclosure

Replacing the backplane

If your system is managed by the IBM Systems Director Management Console (SDMC), use the SDMC to complete the steps for replacing the disk drive backplane in the server. For instructions, see [Replacing a part using the Systems Director Management Console](#).

If your system is managed by the Hardware Management Console (HMC), use the HMC to complete the steps for replacing the disk drive backplane in the server. For instructions, see Exchanging a part using the Hardware Management Console.

If you do not have an HMC or SDMC, complete the following steps to replace the disk drive backplane:

1. Identify the system that you will be working on by using the identify the system process to turn on the system locate (blue) indicator. For more information, see Control panel LEDs.
2. Complete the prerequisite tasks as described in Before you begin.
3. Disconnect the power from the 5802 expansion unit by unplugging the system.

Note: This system has a second power supply. Before continuing with this procedure, ensure that the power source to the system has been completely disconnected.

(L003)

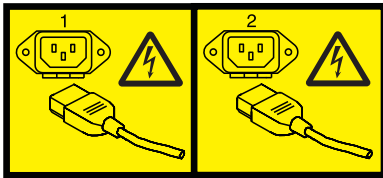

or



4. Open the front rack door.
5. Use the service indicator light-emitting diodes (LEDs) to help identify the part, as described in Identifying a failing part.
6. To replace the disk drive backplane or backplane filler, lift the disk drive backplane along the two sides and align it with the guide rails in the expansion unit.

CAUTION:

The disk drive backplane for the 5802 expansion unit might be heavy. Ensure that you can safely perform this task before you begin.

7. Using your hand to support the bottom of the disk drive backplane or backplane filler, slide it into the expansion unit as shown in Figure 5 on page 7 or Figure 6 on page 7.
8. Secure the disk drive backplane in place by moving the locking tabs from the open position (B) to the locked position (A).

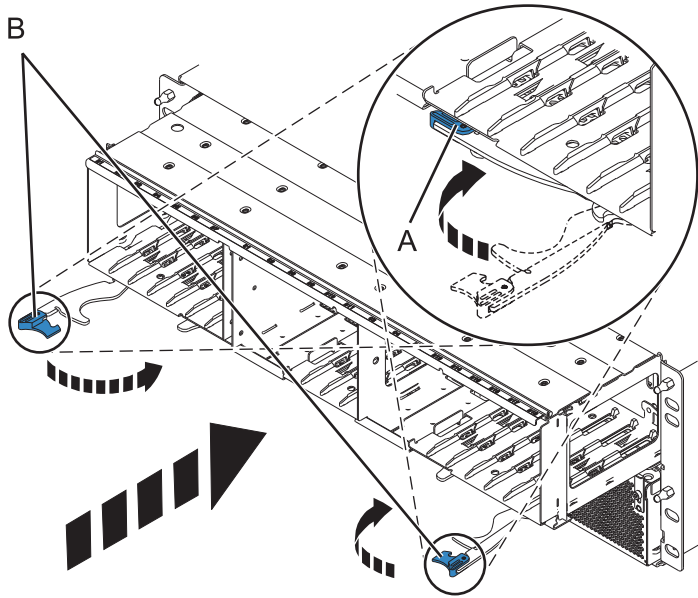

Figure 5. Installing the disk drive backplane in a rack-mounted model

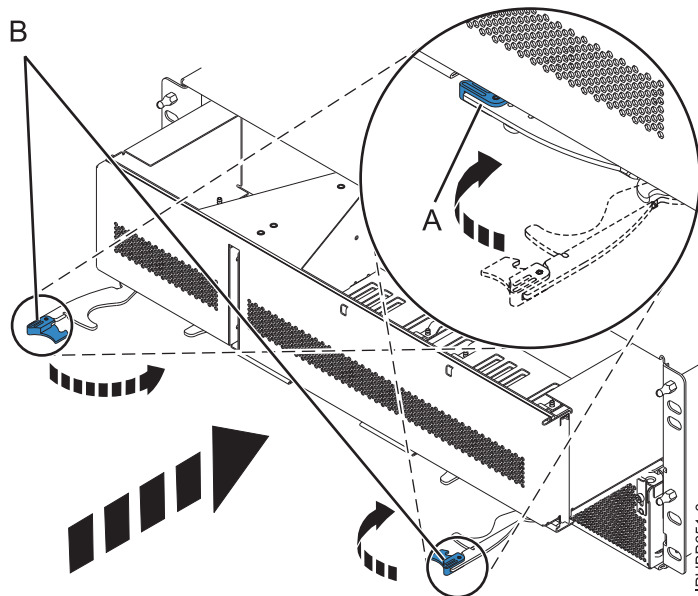

Figure 6. Installing the backplane filler in a rack-mounted model

9. Replace all disk drive units and fillers, if you removed them earlier. Use the location information that you recorded while removing the disk drives to install them the correct locations.
 - a. Support the bottom of the disk drive unit as you align it with the guide rails in the disk drive backplane.
 - b. Slide the disk drive unit all the way into the disk drive backplane.
 - c. Move the handle (A) toward the disk drive unit to lock it in place.

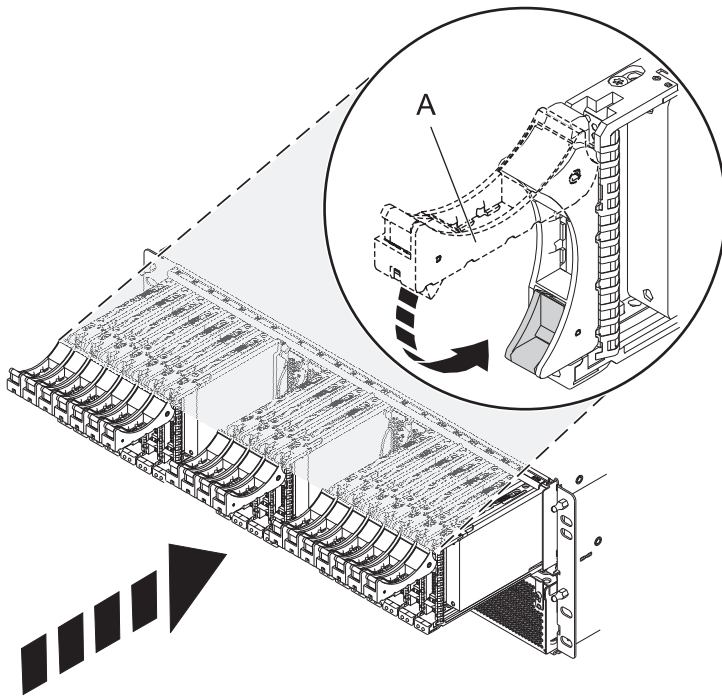

Figure 7. Installing drives and fillers

10. Replace all expander cards and fillers, if you removed them earlier.
 - a. Supporting the bottom of the expander card with your hand, align it with the guide rails in the disk drive backplane.
 - b. Slide the expander card all the way into the disk drive backplane.
 - c. Move the handle (**A**) toward the card to lock it in place.

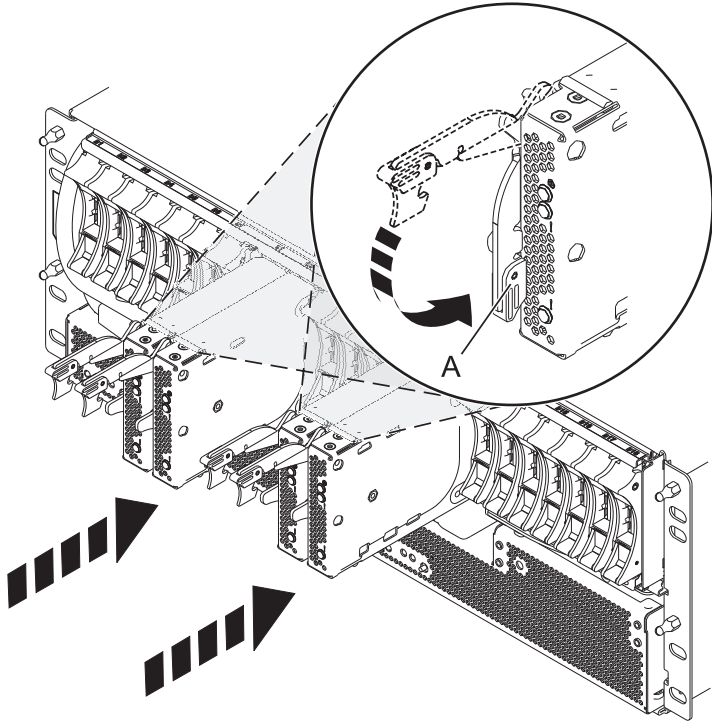

Figure 8. Installing the expander cards

11. Connect the power cords to the back of the enclosure as shown in Figure 9.

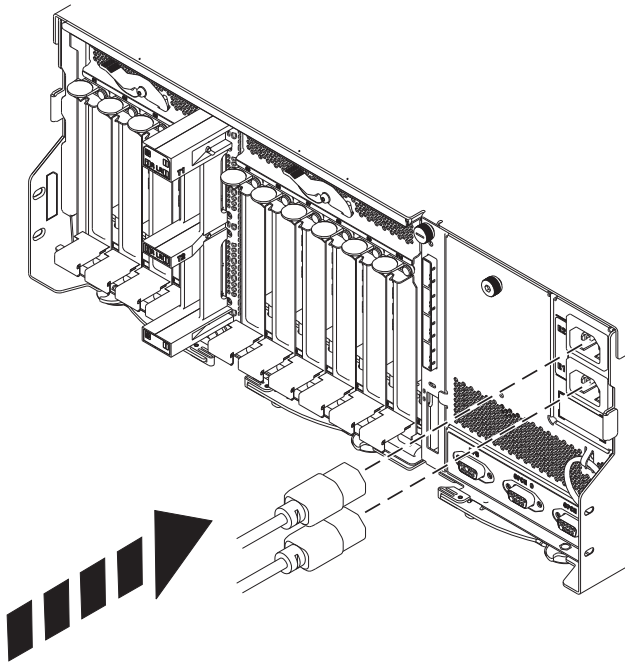

Figure 9. Connecting the power cords

12. Close the front rack door.

13. Start the system. See Starting the system or logical partition.
14. Perform one of the following steps:
 - a. If you replaced the disk drive backplane as part of another procedure, return to that procedure now.
 - b. If you replaced the disk drive backplane because it was not operational, verify that the new resource is operational. For instructions, see Verifying the installed part.

Disk drive (CRU)

Use this procedure to install and remove disk drives.

See Disk drives for instructions on installing and removing disk drives.

Enclosure management controller (CRU)

Use this procedure to install and remove the enclosure management controller (EMC).

Removing the enclosure management controller card

If your system is managed by the Hardware Management Console (HMC), use the HMC to complete the steps for removing the enclosure management controller from the server. For instructions, see Exchanging a part using the Hardware Management Console.

If you do not have an HMC, complete the following steps to remove the enclosure management controller:

1. Perform the prerequisite tasks as described in Before you begin.
2. Complete one of the following choices as appropriate:
 - If you are removing the enclosure management controller for a system upgrade or as part of another procedure, continue to the next step.
 - If you are removing the enclosure management controller because of a system failure, use the service action log to help identify the failing part. For instructions, see Identifying a failing part.
3. Stop the system. For instructions, see Stopping the system or logical partition.
4. Disconnect the power source from the expansion unit by unplugging both power cords from the rear of the enclosure.

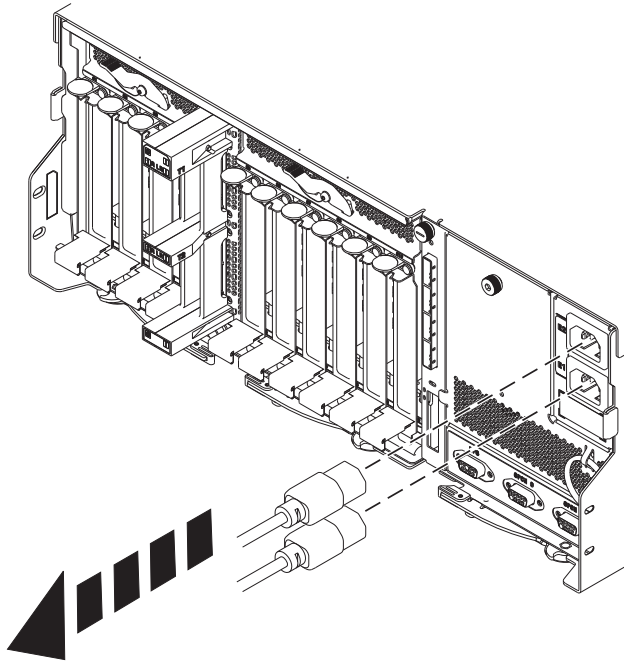

5. Squeeze in on the latch **(B)** and pull the lever **(A)** away from the system as shown in the following figure.

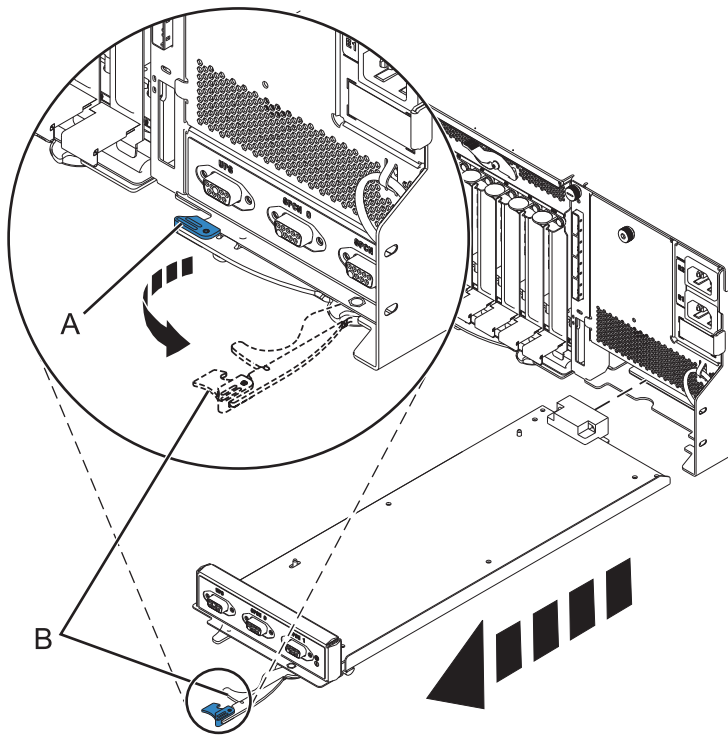

Figure 10. Removing the enclosure management controller from the system

6. Pull the enclosure management controller out of the system.

- If you removed the enclosure management controller as a part of another procedure, continue with that procedure.
- To replace the enclosure management controller or install a new controller, see Replacing the 5802 enclosure management controller.

Replacing the enclosure management controller card

To remove the enclosure management controller, see Removing the 5802 enclosure management controller.

If your system is managed by the Hardware Management Console (HMC), use the HMC to complete the steps for replacing the enclosure management controller in the server. For instructions, see Exchanging a part using the Hardware Management Console.

If you do not have an HMC, complete the following steps to replace the enclosure management controller:

1. Perform the prerequisite tasks as described in Before you begin.
2. Before installing the enclosure management card, inspect the signal connector pins to ensure that the pins are not bent or damaged.

Attention: Bent pins damage the midplane receptacle. Be careful not to touch or damage the signal connector pins.
3. Carefully slide the enclosure management controller into the system and close the latch (A) as shown in the following figure.

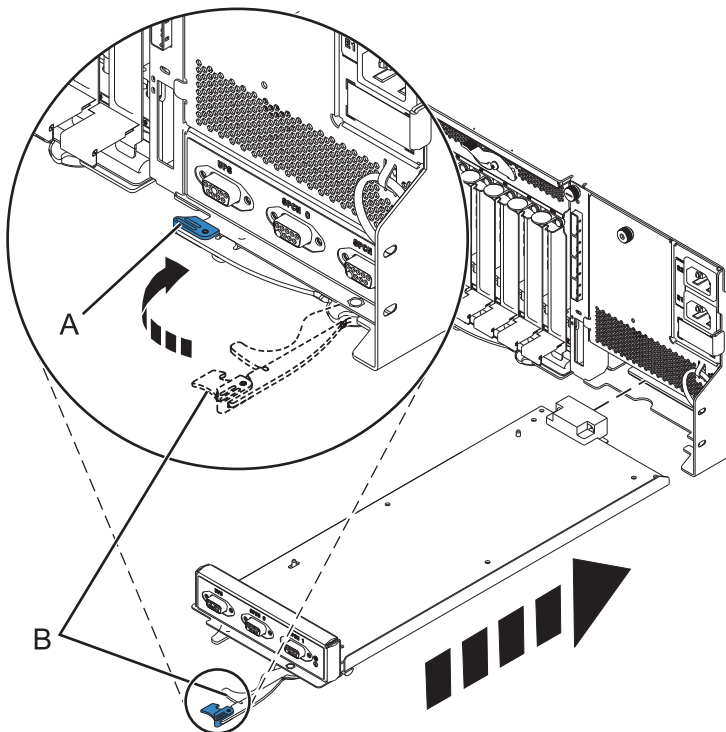
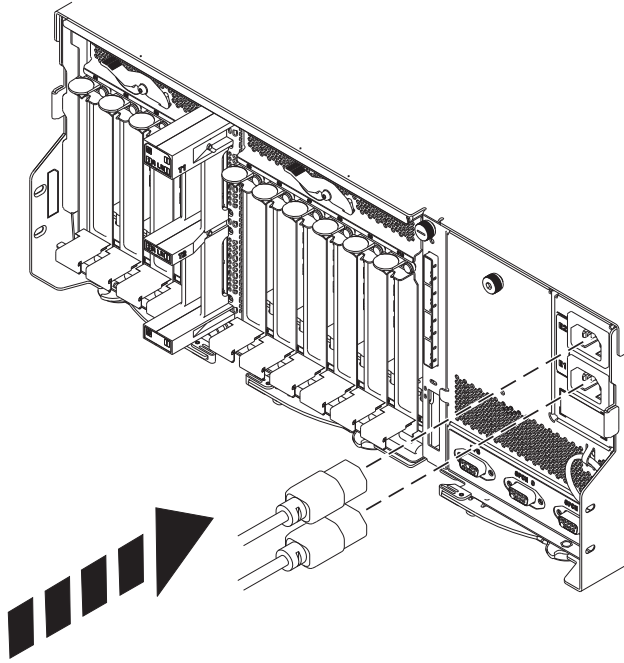

Figure 11. Replacing the enclosure management controller

4. Connect the power source to the expansion unit by connecting both power cords to the rear of the enclosure.



5. Start the system. For instructions see, *Starting the system or logical partition*.
6. Verify the installed part. For instructions, see *Verifying the installed part*.

I/O planar (CRU)

Use this procedure to install and remove the planar.

Removing the I/O planar

If your system is managed by the Hardware Management Console (HMC), use the HMC to complete the steps for removing the I/O planar from the server. For instructions, see “Replacing a part by using the Hardware Management Console” on page 110.

If you do not have an HMC, complete the following steps to remove the I/O planar:

1. Perform the prerequisite tasks described in “Before you begin” on page 63.
2. Do one of the following steps as appropriate:
 - If you are removing the I/O planar for a system upgrade or as part of another procedure, continue to step 3.
 - If you are removing the I/O planar because of a system failure, use the service action log to help identify the failing part. See “Identifying a part” on page 101.
3. Stop the system. For instructions, see “Stopping a system or logical partition” on page 107.
4. Disconnect the power source from the system by unplugging the system.

Note: This system might be equipped with a second power supply. Before continuing with this procedure, ensure that the power source to the system has been completely disconnected.

(L003)

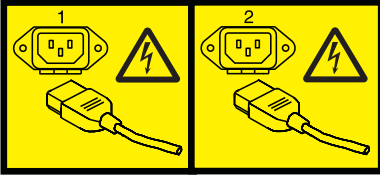

or



5. Disconnect and label the cables from the back of the I/O planar.
6. If you need to replace the I/O planar because of an upgrade or system failure, remove the adapters from the I/O planar. For instructions, see Model 5802 and 5877 expansion units, PCI adapters, and cassettes.
7. Squeeze the release latches (**A**) and pull the levers (**B**) out away from the system, as shown in the following figure.

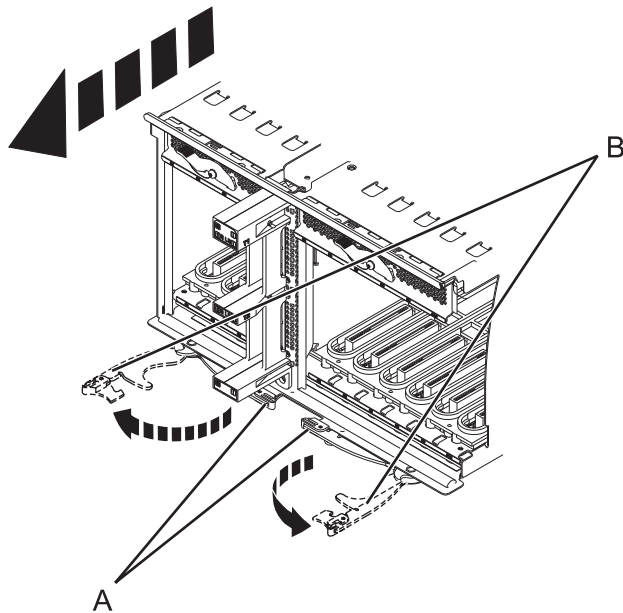

Figure 12. Removing the I/O planar

8. Slide the planar out of the system.

Replacing the I/O planar

To remove the I/O planar, see Removing the 5802 I/O planar.

If your system is managed by the Hardware Management Console (HMC), use the HMC to complete the steps for replacing the I/O planar in the server. For instructions, see Exchanging a part using the Hardware Management Console.

If you do not have an HMC, complete the following steps to replace the I/O planar:

1. Perform the prerequisite tasks as described in Before you begin.
2. Before installing the I/O planar, inspect the signal connector pins to ensure that the pins are not bent or damaged.
Attention: Bent pins damage the midplane receptacle. Be careful not to touch or damage the signal connector pins.
3. Carefully lift and align the I/O planar with the slot at the back of the expansion unit.
4. Insert the I/O planar firmly into the server, as shown in the following figure.
5. Secure the I/O planar with the locking tabs (**A**) as shown in the following figure.

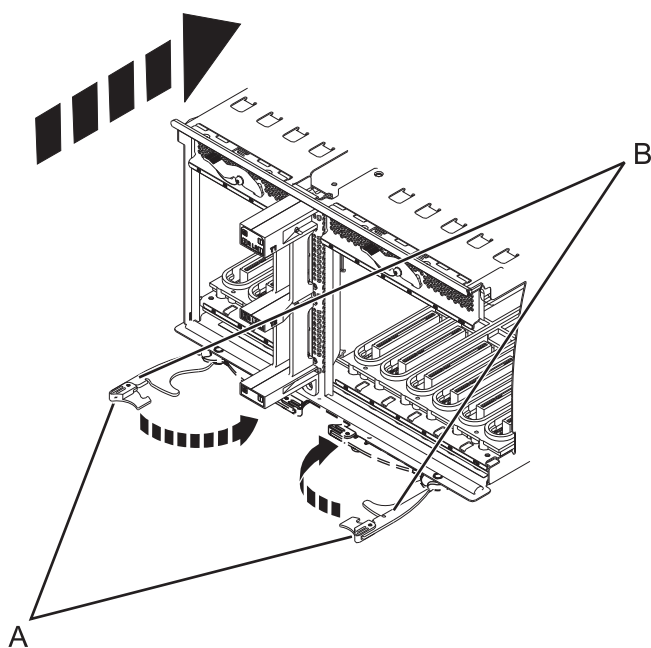

Figure 13. Install the I/O planar

If you are replacing the I/O planar as a part of another procedure, return to that procedure now.

If you are replacing the I/O planar to repair a failed unit, you can now reinstall the adapters and resume operation. For instructions, see Model 5802 and 5877 expansion units, PCI adapters, and cassettes Model 5802 and 5877 expansion units, PCI adapters, and cassettes.

Servicing the Midplane (FRU)

Use these procedures to service the midplane.

Removing the Midplane

If your system is managed by the Hardware Management Console (HMC) use the HMC to remove the Midplane. For instructions see, Removing a part by using the Hardware Management Console.

1. Perform the prerequisite tasks as described in “Before you begin” on page 63.
2. Stop the system. For instructions see, “Stopping a system or logical partition” on page 107.
3. Disconnect the power source from the system by unplugging the system.

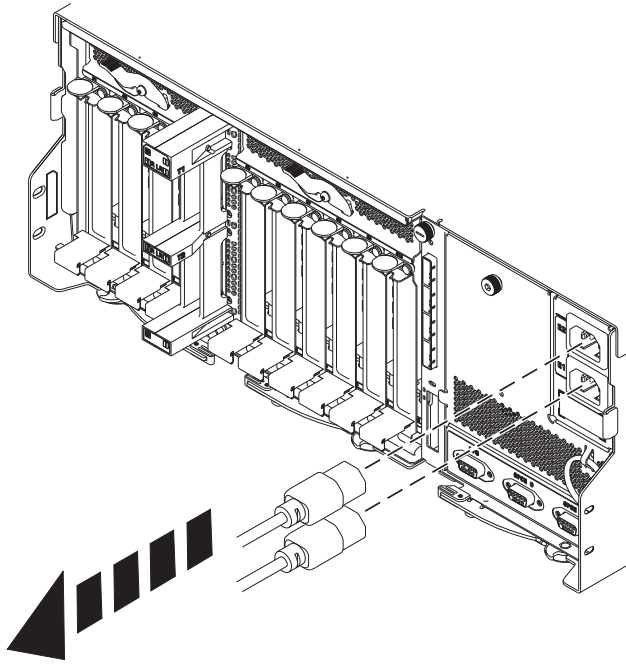

Attention: You must disconnect the power source from the system by disconnecting all power cords to prevent system damage during this procedure.

(L003)

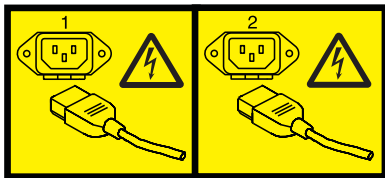

or



4. Before removing a SAS conduit card, inspect the signal connector pins to ensure that the pins are not bent or damaged.

Attention: Bent pins damage the backplane receptacle. Be careful not to touch or damage the signal connector pins.

5. Remove the disk drives and fillers as shown in the following figure. Record the location of each of the disk drives you remove. The disk drives must be installed to the same location again.
 - a. Squeeze the latch of the disk drive and pull the handle (**A**) toward you to release the drives.
 - b. Supporting the bottom of the disk drive with your hand, slide it out of the backplane.

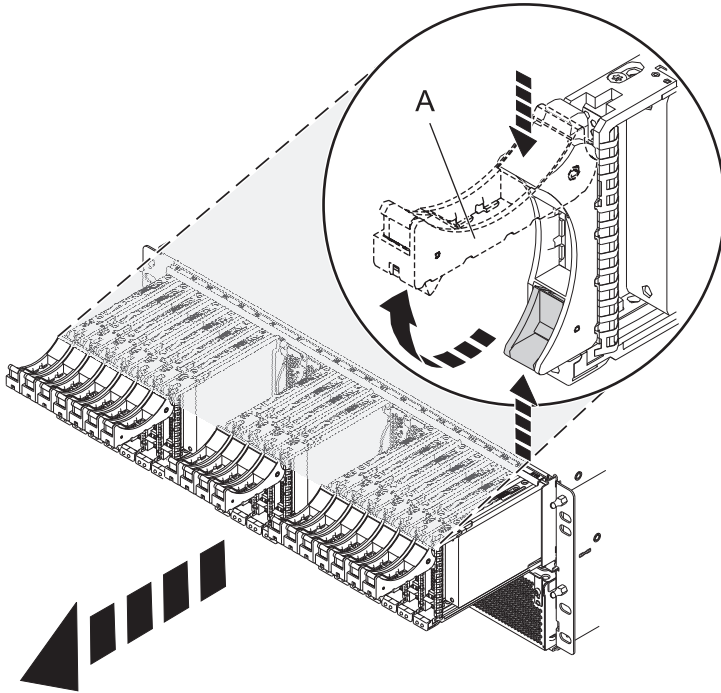

Figure 14. Removing the disk drives from the backplane

6. Remove the port cards and fillers as shown in the following figure.
 - a. Grasp the end of the latching handle (**A**) and pull it upward to unlock the port card.
 - b. Using your hand to support the bottom of the port card, slide it out of the backplane.
 - c. Place the port card on an electrostatic discharge (ESD) surface.

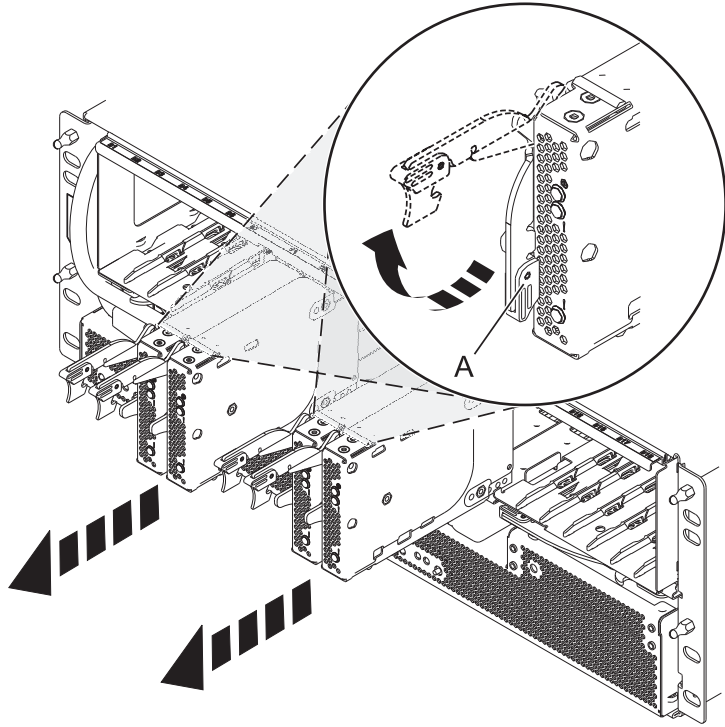

Figure 15. Removing the port card from the backplane

7. Remove the backplane as shown in the following figure.

CAUTION:

The backplane might be heavy. Ensure that you can safely complete the procedure.

- a. Squeeze the blue latches (**A**) to unlock the handles.
- b. Pull the handles (**B**) outward in the direction shown to release the backplane.
- c. Slide the backplane out of the enclosure, using your hand to support the bottom of the backplane.

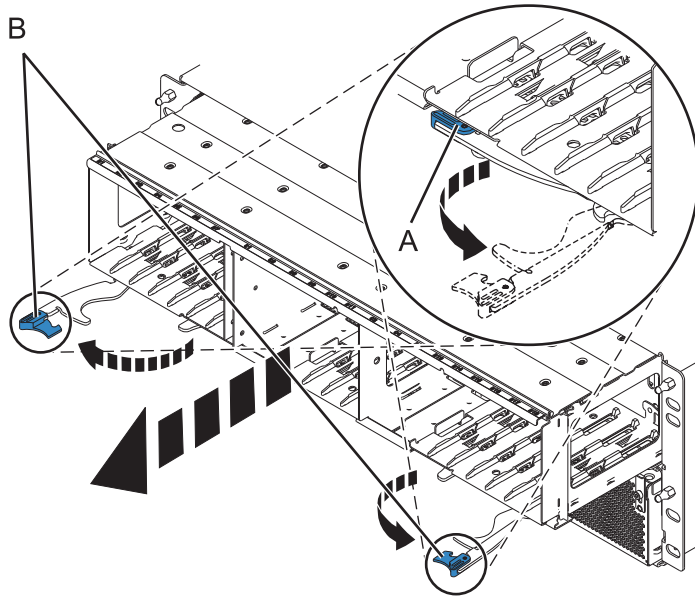

Figure 16. Removing the backplane from the enclosure

8. Disconnect both offline converter assembly (OCA) power cords by doing the following:
 - a. On the front of both OCAs, slide the power cord holders **(A)** to the left.
 - b. Label and disconnect both OCA power cords **(B)** from each OCA.

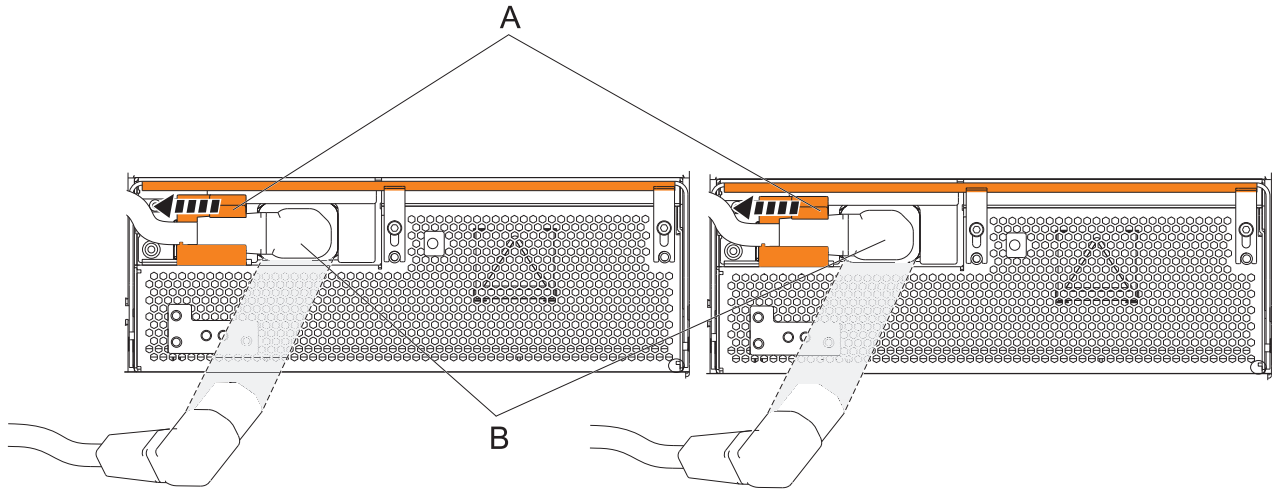

Figure 17. Disconnecting the OCA power cords

9. Remove the offline converter assemblies by doing the following steps:
 - a. Pull the OCA handle (A) all the way down in the direction shown to unseat the OCA.
 - b. Grasp both sides of the OCA and pull it out of the enclosure.

Note: Use 2 hands to support the OCA as it is pulled out of the enclosure.

- c. Repeat these steps to remove both OCAs.

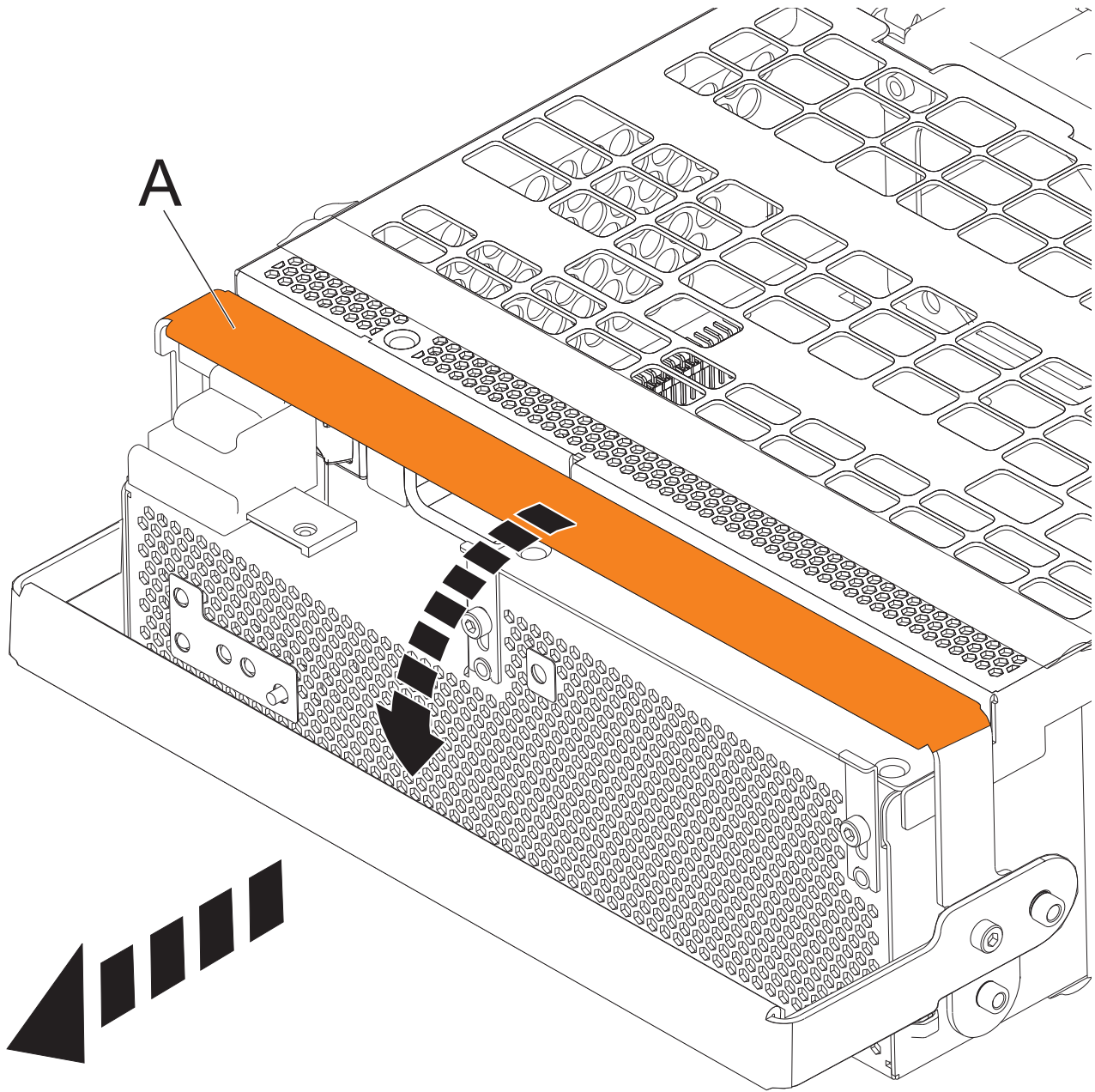
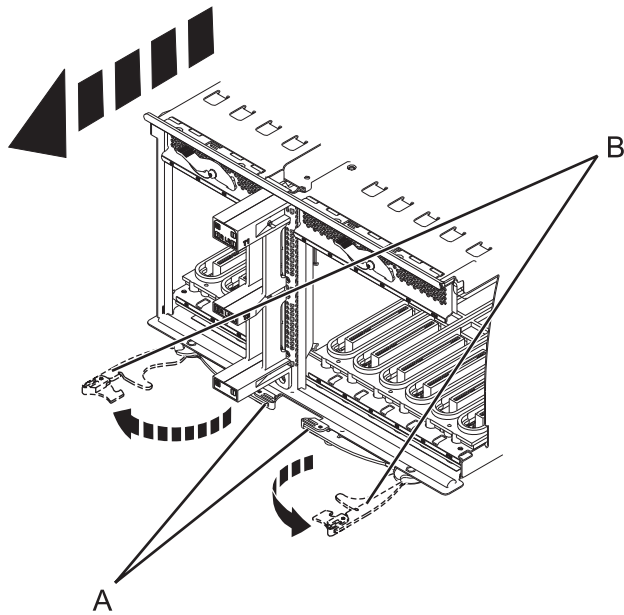

Figure 18. Remove the offline converter assemblies

10. Remove the IO planar
 - a. Label and disconnect any cable connected to the back of the IO planar.
 - b. Pinch the latches (**A**) to unlock the handles.
 - c. Pull the handles (**B**) outward in the direction shown to unseat the IO planar.
 - d. Supporting the bottom of the IO planar, slide the IO planar out of the enclosure.



11. Remove the enclosure management controller card by doing the following steps:
 - a. Label and disconnect any cables connected to the enclosure management controller card.
 - b. Pinch the latch (**A**) to unlock the handle (**B**).
 - c. Pull the handle outward in the direction shown to unseat the EMC card.
 - d. Slide the enclosure management controller card straight out of the enclosure.

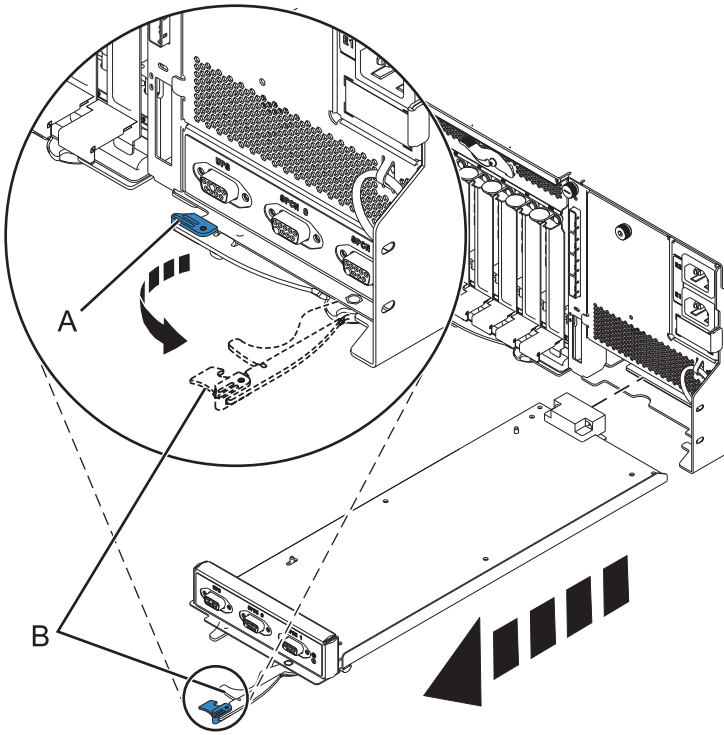

Figure 19. Remove the enclosure management controller

12. Remove the power cord plate by turning the thumbscrew (A) and pulling the plate away from the system.

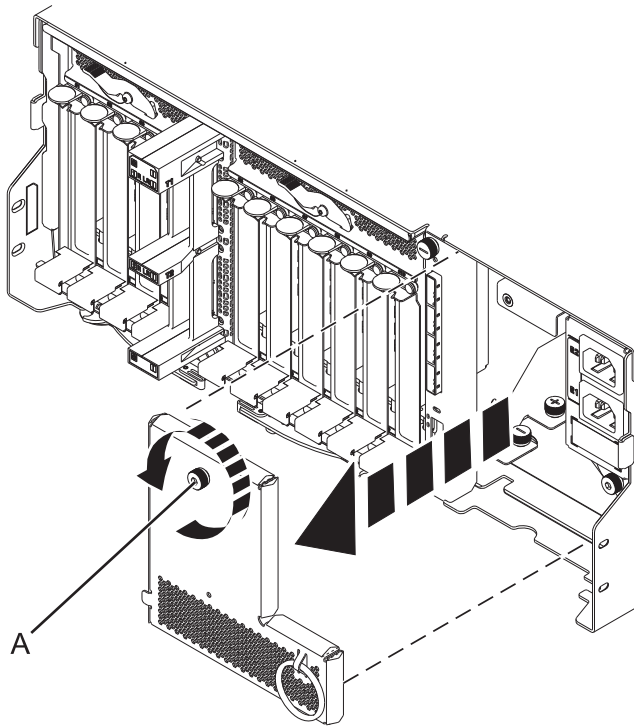

Figure 20. Removing the power cord plate

13. Remove the SAS conduit card and midplane from the enclosure by doing the following steps:

- a. Pull the spring plungers (A) up and turn them one quarter to the left.
- b. Turn the captive screws (B) and (C) counterclockwise until they are completely loosened.
- c. Pull the SAS conduit and midplane component out of the enclosure.

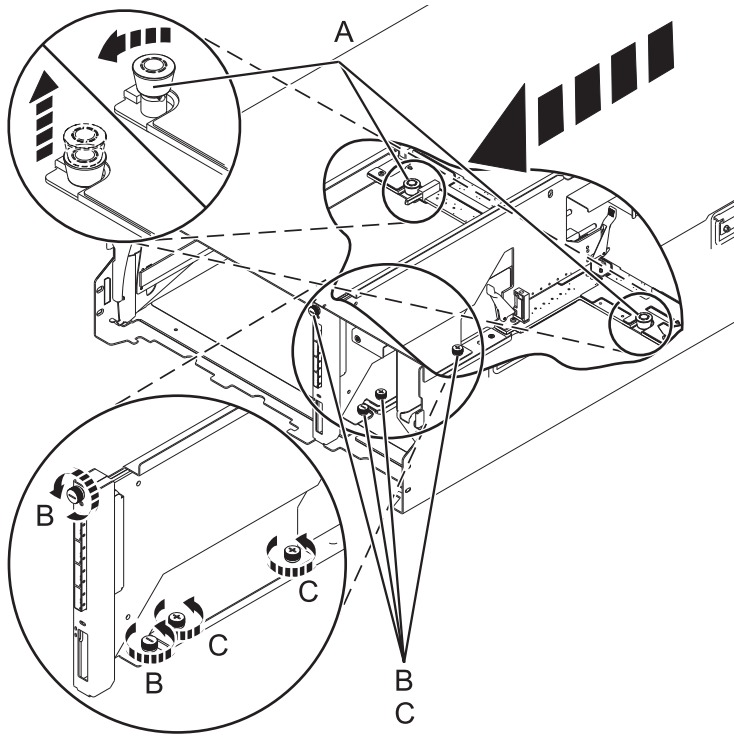

Figure 21. Removing the SAS conduit card and midplane

14. Push the handles (A) on the conduit card down to disengage the card from the midplane, and remove the card.

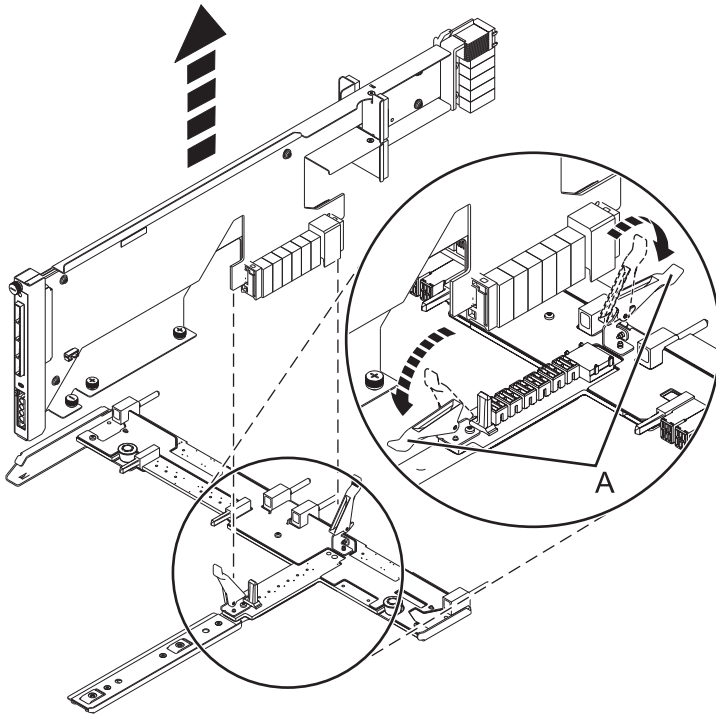

Figure 22. Removing the SAS conduit card from the midplane

Replacing the Midplane

Learn how to replace the Midplane in a 5802 expansion unit with power off.

Review the requirements in “Before you begin” on page 63.

If your system is managed by the Hardware Management Console (HMC), use the HMC to replace the card. For instructions see, Removing a part by using the Hardware Management Console.

1. Stop the system if it is running. For instructions see, “Stopping a system or logical partition” on page 107.
2. Disconnect the power source from the system by unplugging the system.

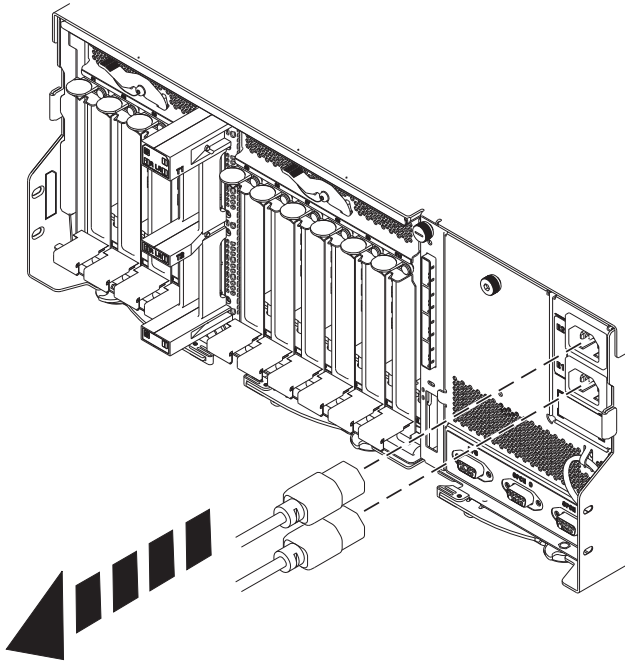

Attention: You must disconnect the power source from the system by disconnecting all power cords to prevent system damage during this procedure.

(L003)

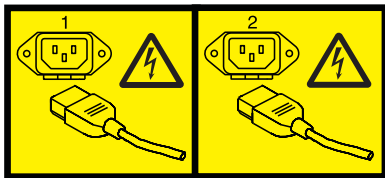

or



3. Before removing a SAS conduit card, inspect the signal connector pins to ensure that the pins are not bent or damaged.
Attention: Bent pins damage the backplane receptacle. Be careful not to touch or damage the signal connector pins.
4. Place the card connector (C) onto the on the midplane connection (D) using the guide track (B) to ensure a good connection. Then lift the handle (A) to seat and secure the SAS conduit card to the midplane as shown in the following figure.

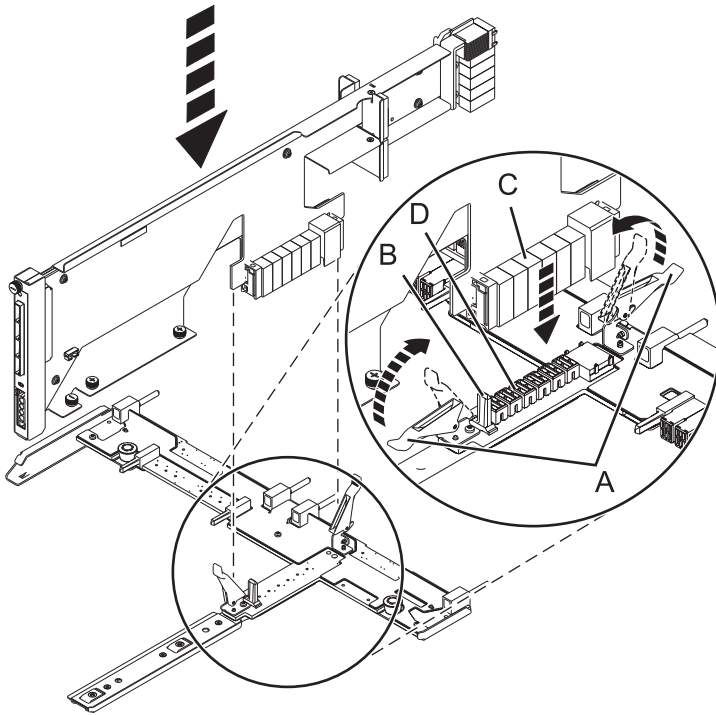

Figure 23. Installing the SAS conduit card into the midplane

5. Place the midplane and SAS conduit card back into the system by doing the following steps:
 - a. Align the midplane with the track and ensure the slot (A) on the midplane attaches to the post (B) in the system.
 - b. Secure the thumbscrews (C) and (D) on the SAS conduit card.
 - c. Secure the thumbscrews (E) on the sides of the midplane.

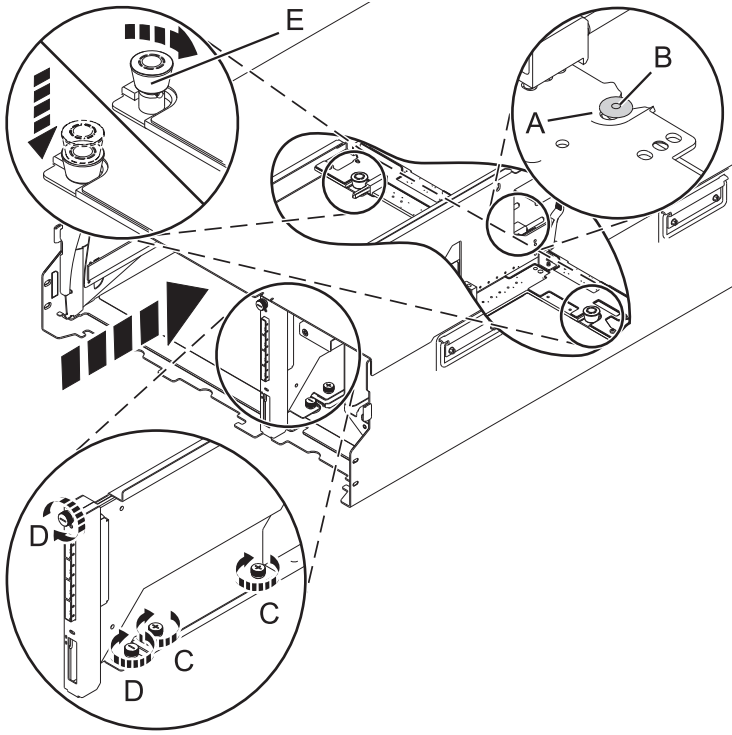

Figure 24. Installing the SAS conduit card and the midplane

6. Attach the power cord cover and secure the thumbscrew (A) to the system.

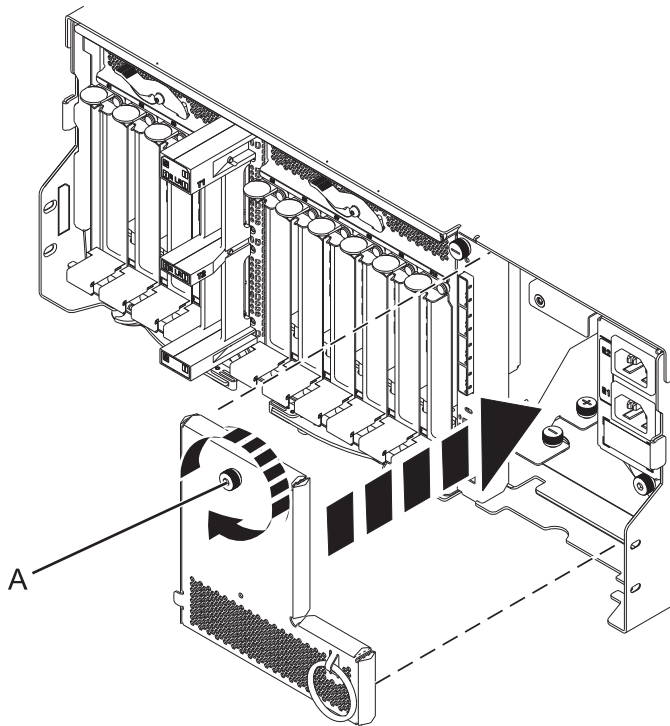

Figure 25. Installing the power cord plate

- Carefully slide the enclosure management controller into the system and close the latch (A) as shown in the following figure.

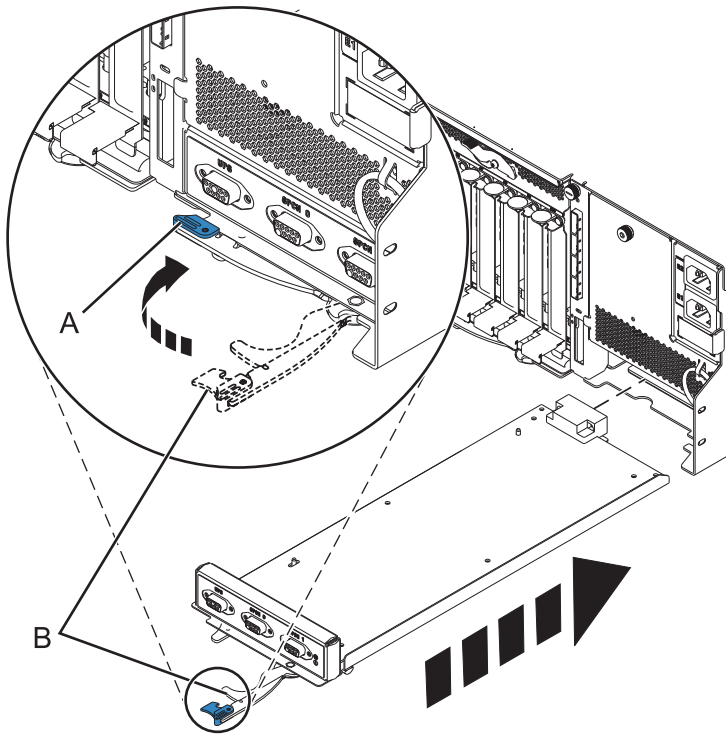
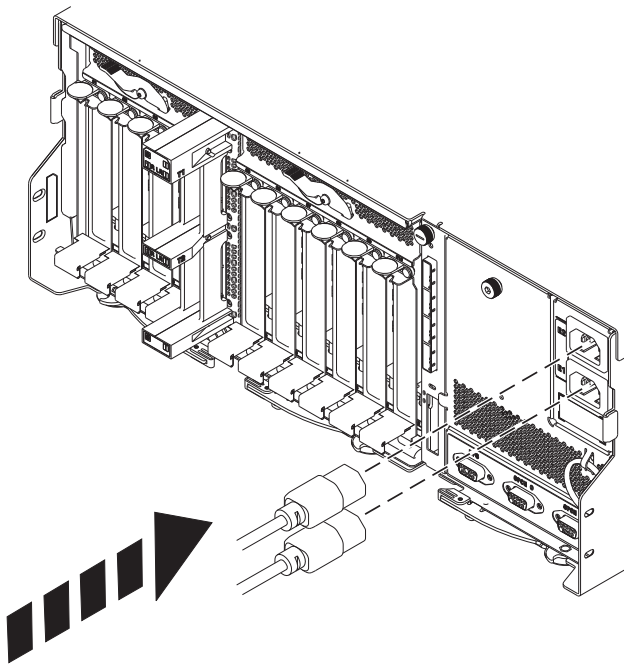

Figure 26. Replacing the enclosure management controller

- Reconnect power to the 5802 expansion unit by re-plugging both power cords to the rear of the enclosure.



9. Carefully lift and align the I/O planar with the slot at the back of the expansion unit.
10. Insert the I/O planar firmly into the server, as shown in the following figure.
11. Secure the I/O planar with the locking tabs (A) as shown in the following figure.

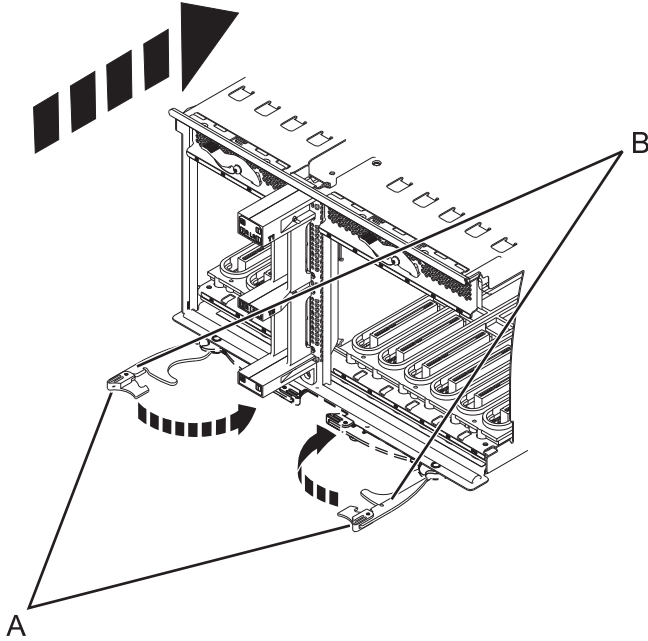

Figure 27. Install the I/O planar on a rack mounted model

12. To replace the power supply, with the locking handle (A) in the open position, push the power supply into the expansion unit as shown in the following figure.
13. Close the locking handle (A) until the power supply locks into position.

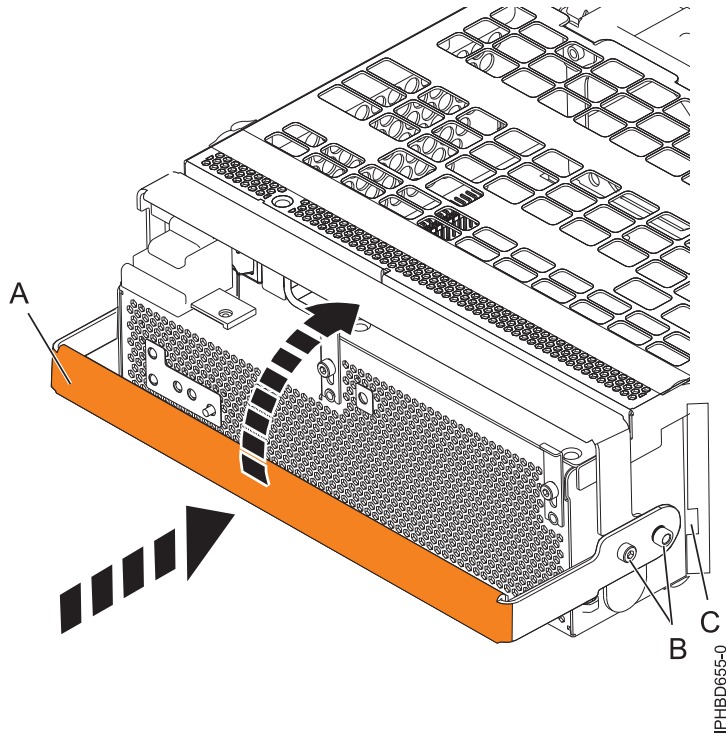

Figure 28. Replacing a power supply

14. Reconnect the power cable (A) to the front of the power supply, and then slide the cable retention bracket (B) to the closed position to secure the cable. By moving the bracket to the closed position, you turn the power supply on.

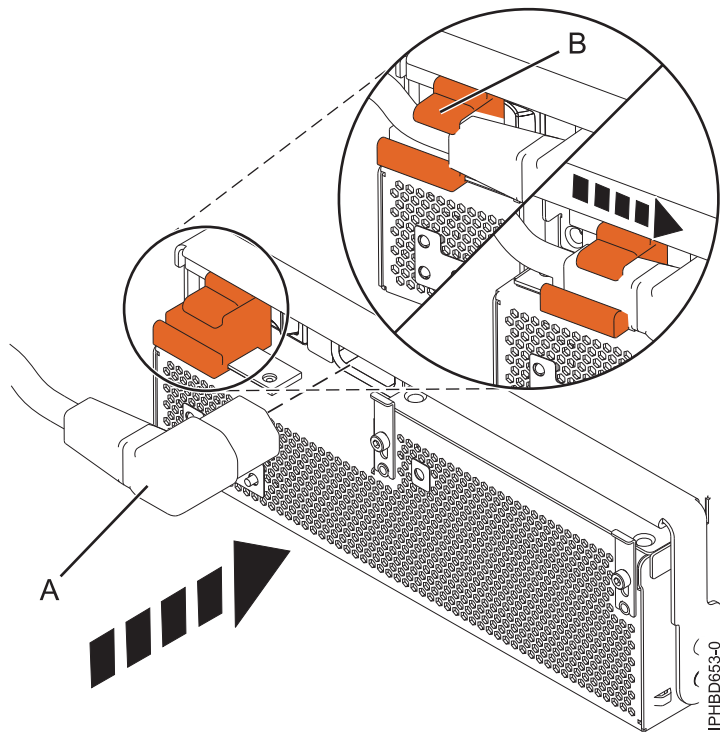

Figure 29. Connecting the power cable to the front of an expansion unit

15. Note the state of the green ac power in (A) and Offline Converter Assembly (OCA) power (B) light-emitting diodes (LEDs), and do one of the following actions, as applicable:
 - If the LEDs indicate that the power supply is operating normally, that is, that the ac power in LED (A) is on solid and the OCA power (B) LED is on solid or blinking, continue to the next step.
 - If not, remove the power supply from the expansion unit and repeat the procedure. If, after repeating the procedure, the power supply is not operating normally, contact your service provider.
16. To replace the disk drive backplane, lift the backplane along the two sides and align with the guide rails in the expansion unit.

CAUTION:
The backplane may be heavy. Ensure that you can safely perform this task before you begin.
17. Using your hand to support the bottom of the backplane, slide it into the expansion unit as shown in the following figure.
18. Secure the backplane in place by moving the locking tabs from the open position (B) to the locked position (A).

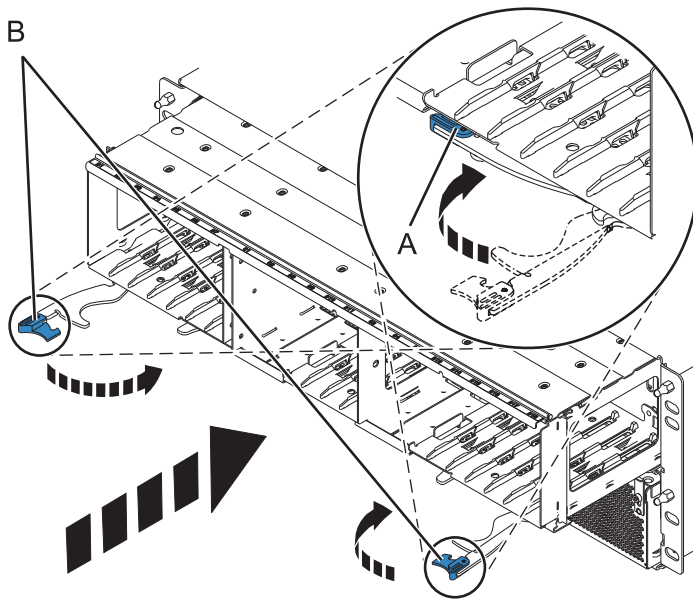

Figure 30. Installing the backplane on a rack-mounted model

19. Start the system. For instructions see, “Starting the system or logical partition” on page 105.

PCI adapters

Learn about installing, removing, and replacing Peripheral Component Interconnect (PCI) adapters in 5802 and 5877 expansion units.

Related reference

 [Managing PCI adapters](#)

Find specifications, instructions, and part numbers for specific adapters.

 [PCI adapter placement for machine types 82xx and 91xx](#)

Find PCI adapter placement information for machine types 82xx and 91xx.

 [PCI adapter placement for machine type 94xx](#)

Find PCI adapter placement information for machine type 94xx.

Preparing to install, remove, or replace a PCI adapter cassette

Learn about steps you must do before you install, remove, or replace a PCI adapter cassette in a 5802 or 5877 expansion unit.

If your system is managed by the Hardware Management Console (HMC), use the HMC to complete the steps for installing a PCI adapter. For instructions, see [Installing a feature using the Hardware Management Console](#).

If your system is managed by the IBM Systems Director Management Console (SDMC), use the SDMC to install, remove, and replace features. For information about using the SDMC, see [Installing a feature by using the Systems Director Management Console](#), [Removing a part by using the Systems Director Management Console](#), or [Replacing a part by using the Systems Director Management Console](#).

Notes:

- If the system is partitioned, you must determine the partition owning the I/O slot. Once the adapter is installed, the I/O slot must be powered on in the operating system.
- If an I/O slot on a partitioned system is not owned by a partition, then the I/O slot cannot be powered on.
- Adding an I/O slot to a partition using Dynamic Logical Partitioning (DLPAR) will power on the I/O slot as part of the DLPAR add. For information about DLPAR, see [Dynamic Logical Partitioning](#).
- To learn more about working in a partitioned environment, see [Logical partitioning](#).

If you do not have an HMC or SDMC, complete the following steps to install, remove or replace a PCI adapter:

1. Perform prerequisite tasks as described in “Before you begin” on page 63.
2. Take appropriate precautions for avoiding electric shock and handling static-sensitive devices. For information, see “Safety notices” on page v and “Handling static-sensitive devices” on page 67.
3. If you are installing a new adapter, determine in which slot to place the new adapter. See the [PCI adapter placement](#).
4. If you are removing a failing PCI adapter, see [Identifying a failing part](#).
5. If you are installing a PCI adapter in a rack-mounted system or expansion unit, open the rear rack door.
6. Determine the location of PCI adapter cassette in the system.

Related information

 [Installing a feature using the Hardware Management Console](#)

 [Logical partitioning](#)

Installing a PCI adapter contained in a cassette

You can install a PCI adapter cassette in a 5802 or 5877 expansion unit.

Installing a PCI adapter cassette with the power off:

You can install a PCI adapter cassette in a 5802 or 5877 expansion unit with the power off.

Before you begin: Prepare to install a PCI adapter cassette. See “Preparing to install, remove, or replace a PCI adapter cassette” on page 34.

To install an adapter with the system power off, do the following steps:

1. Stop the system or logical partition. See Stop the system or logical partition.
2. Disconnect the power source from the system by unplugging the system.
3. Remove the PCI adapter cassette from the system. Refer to “Removing a PCI adapter cassette from the expansion unit” on page 39.
4. Install the adapter into the PCI adapter cassette. Refer to “PCI adapter single-width and double-width cassettes” on page 46.
5. Install the PCI adapter cassette in the system. Refer to “Installing a PCI adapter contained in a cassette” on page 34.
6. Start the system or logical partition. Refer to Start the system or logical partition.
7. Verify that the new resource is functional. See Verify the installed part.

Installing a PCI adapter cassette:

You can install a PCI adapter cassette in a 5802 or 5877 expansion unit.

1. Ensure that the lower cassette handle (C) is pressed up toward the retainer clip. This places the adapter in the correct position to be docked in the system. See the following figure.
2. Slide the cassette into the cassette slot.
3. When the cassette is fully inserted into the system, firmly press downward on the lower cassette handle (C) to lock the adapter in its connector.

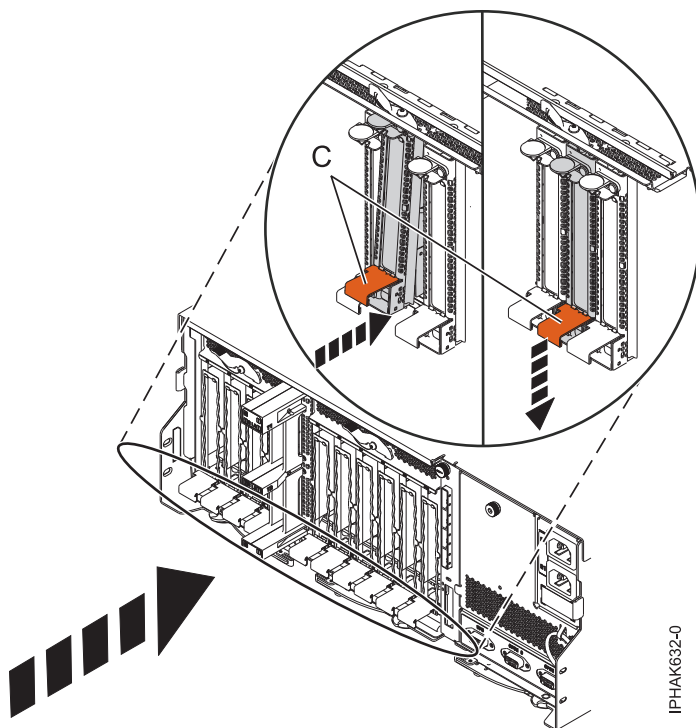
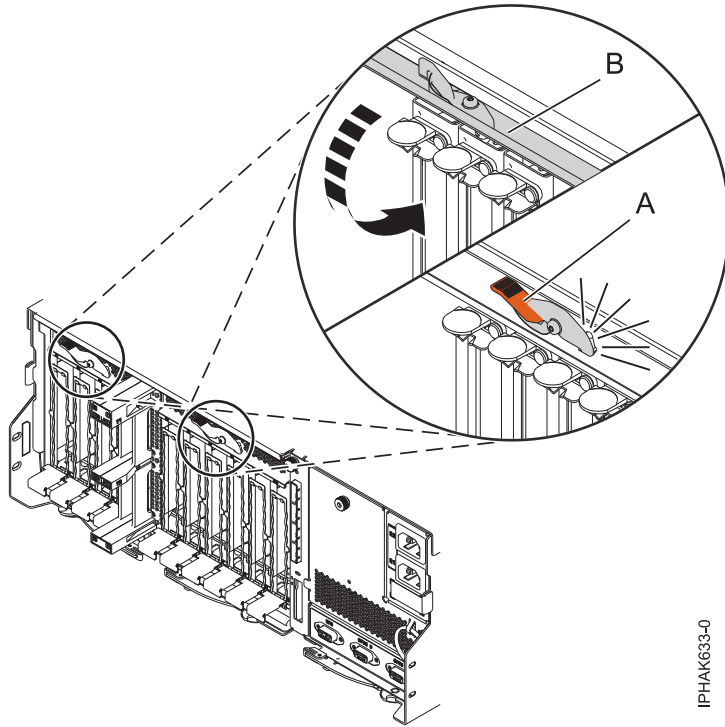

Figure 31. Installing the PCI adapter cassette

4. Lower the access door (B) into the closed position. Latch (A) automatically latches to hold the access door closed.



IPHAK633-0

Figure 32. Closing the access door

5. Return to the procedure that sent you here.

Installing a PCI adapter contained in a cassette with the power on in the AIX environment:

You can install a PCI adapter cassette in a 5802 or 5877 expansion unit that is running the AIX[®] environment with the system power on.

Before you begin: Prepare to install a PCI adapter cassette. See “Preparing to install, remove, or replace a PCI adapter cassette” on page 34.

To install an adapter with the system power on in the AIX environment, do the following steps:

1. Refer to “PCI hot-plug manager access for AIX” on page 68, and follow the steps in the access procedure to select **PCI Hot Plug Manager**. Then return here to continue.
2. From the PCI Hot-Plug Manager menu, select **Add a PCI Hot-Plug Adapter** and press Enter. The Add a Hot-Plug Adapter window displays.
3. Select the appropriate PCI slot from the ones listed on the screen, and press Enter.
4. Locate the PCI adapter slot and cassette you want to use.
5. If the cassette you want to use does not contain a PCI adapter, continue to the next step. If the cassette you want to use does contain an active PCI adapter, see “Removing a PCI adapter contained in a cassette from the expansion unit with the power on in AIX” on page 40.
6. Remove the PCI adapter cassette from the system. Refer to “Removing a PCI adapter cassette from the expansion unit” on page 39.
7. Install the adapter into the PCI adapter cassette. Refer to “PCI adapter single-width and double-width cassettes” on page 46.
8. Follow the instructions on the screen to install the adapter until the LED for the specified PCI slot is set to the Action state. See “Component LEDs” on page 71.
9. Install the PCI adapter cassette in the system. Refer to “Installing a PCI adapter contained in a cassette” on page 34.

10. Run the `cfgmgr` command to configure the adapter.
11. Verify that the new resource is functional. See *Verify the installed part*.

Installing a PCI adapter contained in a cassette with the power on in the IBM i environment:

You can install a PCI adapter cassette in a 5802 or 5877 expansion unit that is running the IBM i environment with the system power on.

Before you begin: Prepare to install a PCI adapter cassette. See “Preparing to install, remove, or replace a PCI adapter cassette” on page 34.

To install an adapter with the system power on in the i operating system, do the following steps:

1. Type **strsst** on the command line of the Main Menu and then press Enter.
2. Type your service tools user ID and service tools password on the System Service Tools (SST) Sign On display. Press Enter.
3. Select **Start a service tool** from the System Service Tools (SST) display and press Enter.
4. Select **Hardware service manager** from the Start a Service Tool display and press Enter.
5. Select **Packaging hardware resources (system, frames, cards)** from the Hardware Service Manager display. Press Enter.
6. Type **9** (Hardware contained within package) in the **System Unit** or **Expansion Unit** field of the unit where you are replacing the card. Press Enter.
7. Select the option to **Include empty positions**.
8. Select **Concurrent Maintenance** on the card position where you want to replace the card, and then press Enter.
9. Select the option **Toggle LED blink off/on**. A light-emitting diode (LED) blinks identifying the position you chose. Physically verify that this is the slot where you want to install the adapter.
10. Select the option **Toggle LED blink off/on** to stop the blinking LED.
11. Select the option **Power off domain** on the Hardware Resource Concurrent Maintenance display and press Enter.
12. Wait for the Hardware Resource Concurrent Maintenance display to appear with this message:
Power off complete
13. Locate the PCI adapter slot and cassette you want to use.
14. If the cassette you want to use does not contain a PCI adapter, continue to the next step. If the cassette you want to use does contain an active PCI adapter, see “Removing a PCI adapter contained in a cassette from the expansion unit with the power on in IBM i” on page 41.
15. Remove the PCI adapter cassette from the system. Refer to “Removing a PCI adapter cassette from the expansion unit” on page 39.
16. Install the adapter into the PCI adapter cassette. Refer to “PCI adapter single-width and double-width cassettes” on page 46.
17. Install the PCI adapter cassette in the system. Refer to “Installing a PCI adapter contained in a cassette” on page 34.
18. Select **Power on domain** on the Hardware Resource Concurrent Maintenance display and press Enter.
19. Select **Assign to** on the resource that has an asterisk (*) on the Work with Controlling Resource display. Press Enter.
20. Wait for the Hardware Resource Concurrent Maintenance display to appear with this message:
Power on complete
21. Verify that the new resource is functional. See *Verify the installed part*.

Installing a PCI adapter contained in a cassette with the power on in the Linux environment:

You can install a PCI adapter cassette in a 5802 or 5877 expansion unit that is running the Linux environment with the system power on.

Before you begin: Prepare to install a PCI adapter cassette. See “Preparing to install, remove, or replace a PCI adapter cassette” on page 34.

To install an adapter with the system power on in the Linux environment, do the following steps:

1. Log in to the system console as the root user.
2. Use the `lsslot` tool to list the hot-plug PCI slots that are available in the server or logical partition:

```
lsslot -c pci -a
```

The following is an example of the information displayed by this command:

Slot	Description	Devices
U7879.001.DQD014E-P1-C1	PCI-X capable, 64 bit, 133MHz slot	Empty
U7879.001.DQD014E-P1-C4	PCI-X capable, 64 bit, 133MHz slot	Empty
U7879.001.DQD014E-P1-C5	PCI-X capable, 64 bit, 133MHz slot	Empty

Select the appropriate empty PCI slot from the ones listed by the command.

3. Remove the PCI adapter cassette from the system. Refer to “Removing a PCI adapter cassette from the expansion unit” on page 39.
4. Install the adapter into the PCI adapter cassette. Refer to “PCI adapter single-width and double-width cassettes” on page 46.
5. Ensure the lower cassette handle is pressed up toward the retainer clip. This places the adapter in the correct position to be locked in the system.
6. Run the `drsslot_chrp_pci` command to enable an adapter to be installed.

For example, to install an adapter in slot U7879.001.DQD014E-P1-C3, run:

```
drsslot_chrp_pci -a -s U7879.001.DQD014E-P1-C3
```

The following displays:

```
The visual indicator for the specified PCI slot has been set to the identify state. Press Enter to continue or enter x to exit.
```

7. Press Enter.

The following displays:

```
The visual indicator for the specified PCI slot has been set to the action state. Insert the PCI card into the identified slot, connect any devices to be configured and press Enter to continue. Enter x to exit.
```

8. Install the PCI adapter cassette in the system. Refer to “Installing a PCI adapter contained in a cassette” on page 34.
9. Use the `lsslot` command to verify that U7879.001.DQD014E-P1-C3 is occupied.

```
Enter lsslot -c pci -s U7879.001.DQD014E-P1-C3
```

The following is an example of the information displayed by this command:

Slot	Description	Devices
U7879.001.DQD014E-P1-C3	PCI-X capable, 64 bit, 133MHz slot	0001:40:01.0

Removing a PCI adapter contained in a cassette from the expansion unit

You can remove a PCI adapter cassette from the 5802 or 5877 expansion unit.

Removing a PCI adapter contained in a cassette from the expansion unit with the system power off:

You can remove a PCI adapter cassette from the 5802 or 5877 expansion unit with the system power off.

Before you begin: Prepare to remove a PCI adapter cassette. See “Preparing to install, remove, or replace a PCI adapter cassette” on page 34.

To remove an adapter, do the following steps:

1. Stop the system or logical partition. See Stop the system or logical partition.
2. Disconnect the power source from the system by unplugging the system.
3. Determine the location of PCI adapter in the system.
4. Remove the PCI adapter cassette from the system. Refer to “Removing a PCI adapter cassette from the expansion unit.”
5. Place the cassette with the cover facing up on an approved ESD surface.
6. To remove the adapter from the cassette, refer to “PCI adapter single-width and double-width cassettes” on page 46.

Removing a PCI adapter cassette from the expansion unit:

You can remove a PCI adapter cassette from the 5802 or 5877 expansion unit.

To remove a PCI adapter cassette, do the following steps:

1. Press down on latch (A) to release the access door. The access door is spring loaded, which causes it to rotate up into the open position (B).

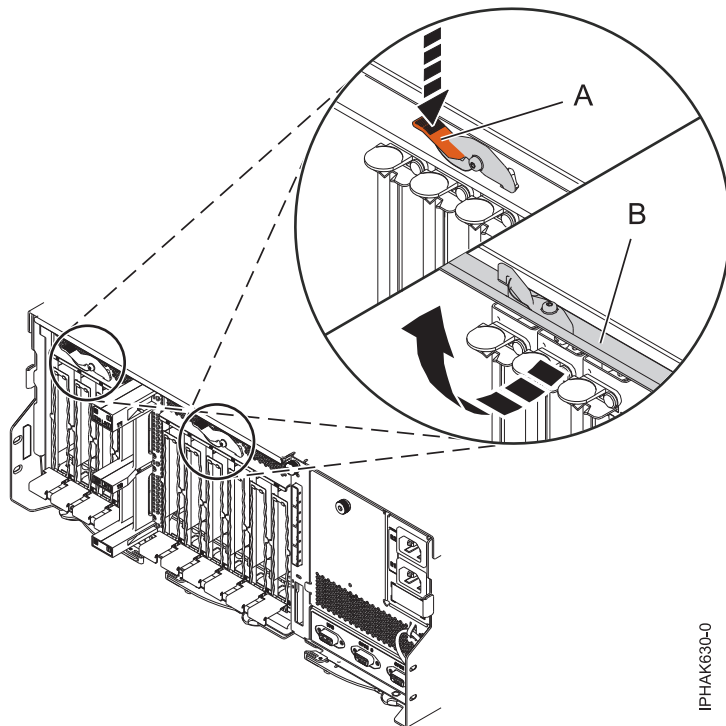

Figure 33. Opening the access door

2. Lift up the lower cassette handle (C) and pull the cassette out of the unit.

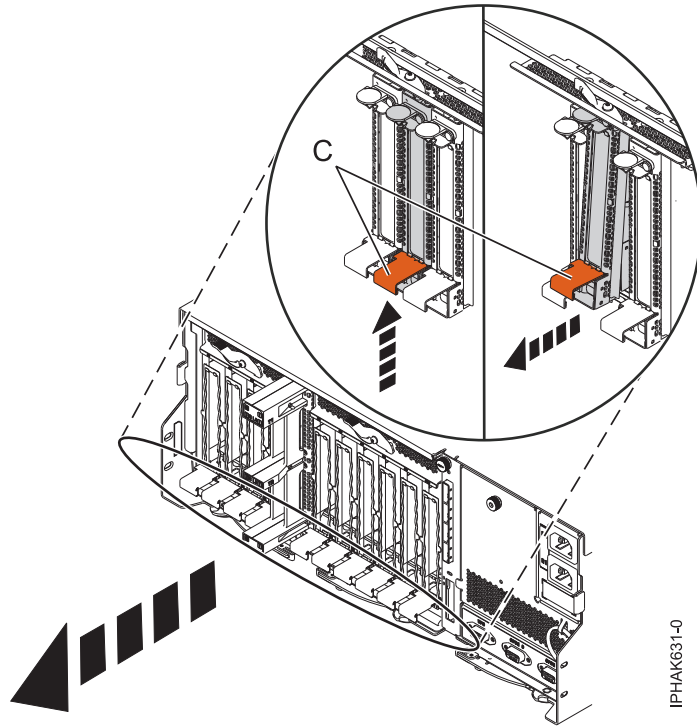

Figure 34. Removing a PCI adapter cassette

Attention: A cassette that contains either a PCI adapter or filler panel must be placed in the PCI adapter slot of the system unit for proper air flow and cooling.

3. Return to the procedure that sent you here.

Removing a PCI adapter contained in a cassette from the expansion unit with the power on in AIX:

You can remove or replace a PCI adapter cassette from the 5802 or 5877 expansion unit that is running the AIX operating system with the system power on.

Before you begin: Prepare to remove a PCI adapter cassette. See “Preparing to install, remove, or replace a PCI adapter cassette” on page 34.

Notes:

1. Use this procedure to remove a PCI adapter and leave the slot in the system unit empty.
2. If the adapter that is removed will be placed into a different slot or system, complete this removal procedure, and then install the adapter as described in “Installing a PCI adapter contained in a cassette with the power on in the AIX environment” on page 36.
3. Procedures performed on a PCI adapter with the system power on in AIX, also known as hot-plug procedures, require the system administrator to take the PCI adapter offline prior to performing the operation. Before taking an adapter offline, the devices attached to the adapter must be taken offline as well. This action prevents a service representative or user from causing an unexpected outage for system users.

To remove an adapter, do the following steps:

1. If you are removing a failing PCI adapter, see Identifying a failing part. If you are removing the PCI adapter for other reasons, continue to the next step.
2. Determine the location of PCI adapter in the system.
3. Record the slot number and location of each adapter being removed.

Note: Adapter slots are numbered on the rear of the system unit.

4. Ensure that any processes or applications that might use the adapter are stopped.
5. Enter the system diagnostics by logging in as root user or as the celogin user, and type **diag** at the AIX command line.
6. When the DIAGNOSTIC OPERATING INSTRUCTIONS menu displays, press Enter.
7. At the FUNCTION SELECTION menu, select **Task Selection**, and then press Enter.
8. At the Task Selection list, select **PCI Hot Plug Manager**.
9. Select **Unconfigure a Device**, and then press Enter.
10. Press F4 (or press Esc+4) to display the **Device Names** menu.
11. Select the adapter you are removing in the **Device Names** menu.
12. Use the Tab key to answer NO to **Keep Definition**. Use the Tab key again to answer YES to **Unconfigure Child Devices**, and then press Enter. The **ARE YOU SURE** screen displays.
13. Press Enter to verify the information. Successful unconfiguration is indicated by the OK message displayed next to the **Command** field at the top of the screen.
14. Press F4 (or press Esc+4) twice to return to the **Hot Plug Manager** menu.
15. Select **Replace/remove PCI Hot Plug adapter**.
16. Select the slot that has the device to be removed from the system.
17. Select **Remove**. A fast-blinking amber LED located at the back of the machine near the adapter indicates that the slot has been identified.
18. Label all cables that are attached to the adapter that you plan to remove.
19. Press Enter. This places the adapter in the action state, meaning it is ready to be removed from the system.
20. Disconnect all cables attached to the adapter that you plan to remove.
21. Remove the PCI adapter cassette from the system. Refer to “Removing a PCI adapter cassette from the expansion unit” on page 39.
22. Place the cassette with the cover facing up on an approved ESD surface.
23. Continue to follow the screen instructions until you receive a message that the adapter removal is successful. Successful removal is indicated by the message OK, which is displayed next to the **Command** field at the top of the screen.
24. If you have other adapters to remove, press the F3 key to return to the PCI Hot-Plug Manager menu, and then return to step 20.
If you do not have other adapters to remove, continue with the next step.
25. Press F10 to exit the Hot-Plug Manager.
26. Run the **diag -a** command. If the system responds with a menu or prompt, follow the instructions to complete the device configuration.
27. To remove the adapter from the cassette, see “PCI adapter single-width and double-width cassettes” on page 46.
28. Place an empty cassette into the unused PCI slot for proper air flow.

Removing a PCI adapter contained in a cassette from the expansion unit with the power on in IBM i:

You can remove a PCI adapter cassette from the 5802 or 5877 expansion unit that is running the IBM i operating system with the system power on.

Before you begin: Prepare to remove a PCI adapter cassette. See “Preparing to install, remove, or replace a PCI adapter cassette” on page 34.

To remove an adapter, do the following steps:

1. Determine the location of PCI adapter in the system.

2. Type `strsst` on the command line of the Main Menu and then press Enter.
3. Type your service tools user ID and service tools password on the System Service Tools (SST) Sign On display and press Enter.
4. Select **Hardware service manager** from the Start a Service Tool display and press Enter.
5. Select **Packaging hardware resources (system, frames, cards)** from the Hardware Service Manager display. Press Enter.
6. Type **9** (Hardware contained within package) in the **System Unit** or **Expansion Unit** field of the unit where you are removing the card. Press Enter.
7. Select the option **Include empty positions**.
8. Select **Concurrent Maintenance** on the card position where you want to remove the card, and then press Enter.
9. Select the option **Toggle LED blink off/on**. A light-emitting diode (LED) blinks identifying the position you chose. Physically verify that this is the slot where you want to install the adapter.
10. Select the option **Toggle LED blink off/on** to stop the blinking LED.
11. Select the option **Power off domain** on the Hardware Resource Concurrent Maintenance display and press Enter.
12. Wait for the Hardware Resource Concurrent Maintenance display to appear with this message:
Power off complete
13. Remove the PCI adapter cassette from the system. Refer to “Removing a PCI adapter cassette from the expansion unit” on page 39.
14. Place the cassette with the cover facing up on an approved ESD surface.
15. To remove the adapter from the cassette, see “PCI adapter single-width and double-width cassettes” on page 46.

Removing a PCI adapter contained in a cassette from the expansion unit with the power on in Linux:

You can remove a PCI adapter cassette from the 5802 or 5877 expansion unit that is running the Linux operating system with the system power on.

Do the following actions before beginning the procedure:

- Follow the steps in “Preparing to install, remove, or replace a PCI adapter cassette” on page 34.
- Ensure that the system meets the “Prerequisites for hot-plugging PCI adapters in Linux” on page 69.
- Verify that the Linux, hot-plug PCI tools are installed. See “Verifying that the hot-plug PCI tools are installed for Linux” on page 70

To remove an adapter, do the following steps:

1. Determine the location of the PCI adapter in the system.
2. Label and then disconnect all cables attached to the adapter you plan to remove.
3. Run the `drslot_chrp_pci` command to enable an adapter to be removed:
For example, to remove the PCI adapter in slot U7879.001.DQD014E-P1-C3 run this command:
`drslot_chrp_pci -r -s U7879.001.DQD014E-P1-C3`
Follow the instructions on the display to complete the task.
4. Remove the PCI adapter cassette from the system. Refer to “Removing a PCI adapter cassette from the expansion unit” on page 39.
5. Place the cassette with the cover facing up on an approved ESD surface.
6. To remove an adapter from the cassette, refer to “PCI adapter single-width and double-width cassettes” on page 46.

Replacing a PCI adapter contained in a cassette from the expansion unit with the power off:

You can replace a PCI adapter cassette from the 5802 or 5877 expansion unit with the system power off.

You must have already completed the procedure “Removing a PCI adapter contained in a cassette from the expansion unit with the system power off” on page 38 to have the slot powered off.

To replace an adapter with the system power off, do the following steps:

1. If the adapter needs to be placed in a PCI adapter cassette, see “PCI adapter single-width and double-width cassettes” on page 46.
2. At the back of the system, lift the cassette cover flap and identify the cassette slot you want to use.
3. Ensure the lower cassette handle is pressed up toward the retainer clip. This places the adapter in the correct position to be docked in the system.
4. Install the PCI adapter cassette in the system. Refer to “Installing a PCI adapter contained in a cassette” on page 34.
5. Reconnect the system to the power source.
6. Start the system or logical partition. Refer to Start the system or logical partition.
7. Verify that the new resource is functional. See Verify the installed part.

Replacing a PCI adapter contained in a cassette from the expansion unit with the power on in AIX:

You can remove or replace a PCI adapter cassette from the 5802 or 5877 expansion unit that is running the AIX operating system with the system power on.

Before you begin: Prepare to replace a PCI adapter cassette. See “Preparing to install, remove, or replace a PCI adapter cassette” on page 34.

Important:

- Use this procedure if you intend to remove a failing PCI adapter and replace it with the same type of adapter. If you plan to remove a failing adapter and leave the slot empty, see “Removing a PCI adapter contained in a cassette from the expansion unit with the power on in AIX” on page 40.
- Do not use this procedure to remove an existing adapter and install a different type of adapter. To install a different adapter, remove the existing adapter as described in “Removing a PCI adapter contained in a cassette from the expansion unit with the power on in AIX” on page 40, and then install the new adapter as described in “Installing a PCI adapter contained in a cassette with the power on in the AIX environment” on page 36.
- Procedures performed on a PCI adapter with the system power on in AIX, also known as hot-plug procedures, require the system administrator to take the PCI adapter offline prior to performing the operation. Before taking an adapter offline, the devices attached to the adapter must be taken offline as well. This action prevents a service representative or user from causing an unexpected outage for system users.

To replace an adapter, do the following steps:

1. Determine the location of the PCI adapter in the system.
2. Record the slot number and location of each adapter being removed.

Note: Adapter slots are numbered on the rear of the system unit.

3. Ensure that any processes or applications that might use the adapter are stopped.
4. Enter the system diagnostics by logging in as root user or as the celogin user, and type **diag** at the AIX command line.
5. When the DIAGNOSTIC OPERATING INSTRUCTIONS menu displays, press Enter.
6. At the FUNCTION SELECTION menu, select **Task Selection**, and then press Enter.
7. At the Task Selection list, select **PCI Hot Plug Manager**.
8. Select **Unconfigure a Device**, and then press Enter.

9. Press F4 (or Esc+4) to display the **Device Names** menu.
10. Select the adapter that you are removing in the **Device Names** menu.
11. Use the Tab key to answer YES to **Keep Definition**. Use the Tab key again to answer YES to **Unconfigure Child Devices**, and then press Enter. The **ARE YOU SURE** screen displays.
12. Press Enter to verify the information. Successful unconfiguration is indicated by the message OK, which is displayed next to the **Command** field at the top of the screen.
13. Press F3 (or Esc+3) twice to return to the **Hot Plug Manager** menu.
14. Select **Replace/remove PCI Hot Plug adapter**.
15. Select the slot that has the device to be removed from the system.
16. Select **Replace**.

Note: A fast-blinking amber LED located at the back of the machine near the adapter indicates that the slot has been identified.

17. Press Enter. This places the adapter in the action state, meaning it is ready to be removed from the system.
18. Label and then disconnect all cables attached to the adapter that you plan to remove.
19. Remove the PCI adapter cassette from the system. Refer to “Removing a PCI adapter cassette from the expansion unit” on page 39.
20. Place the cassette with the cover facing up on an approved ESD surface.
21. Install the adapter into the PCI adapter cassette. Refer to “PCI adapter single-width and double-width cassettes” on page 46.
22. At the back of the system, lift the cassette cover flap and identify the cassette slot you want to use.
23. Ensure the lower cassette handle is pressed up toward the retainer clip. This places the adapter in the correct position to be docked in the system.
24. Install the PCI adapter cassette in the system. Refer to “Installing a PCI adapter contained in a cassette” on page 34.
25. Press Enter and continue to follow the screen instructions until you receive a message that the replacement is successful. Successful replacement is indicated by the message OK, which is displayed next to the **Command** field at the top of the screen.
26. Press the F3 (or Esc+3) key to return to the **PCI Hot-Plug Manager** menu.
27. Press the F3 (or Esc+3) key to return to the **TASK** selection list.
28. Select **Log Repair Action**.
29. Select the resource just replaced, press Enter, press Commit (F7 or ESC 7), and then press Enter.
30. Press F3 (or Esc+3) to return to **TASK Selection List**.
31. Select **Hot Plug Task**, press Enter.
32. Select **PCI Hot Plug Manager**, and then select **Configure a defined device**, then press Enter.
33. Select the device just replaced from the list, and then press Enter. The device is now configured.
34. Press the F10 key to exit the diagnostic program.
35. Verify the PCI adapter by using the following instructions:
 - a. Did you replace the adapter with the system power on?
 - Yes: Go to the next step.
 - No: Load the diagnostic program by doing the following steps:
 - If AIX is available, boot AIX, log in as root or CELOGIN, and then enter the **diag** command.
 - b. Type the **diag** command if you are not already displaying the diagnostic menus.
 - c. Select **Advance Diagnostic Routines**, and then select **Problem Determination**.
 - d. Select the name of the resource just replaced from the menu. If the resource just replaced is not shown, choose the resource associated with it. Press Enter, and then press **Commit** (F7 or Esc+7).

- e. Did the Problem Determination identify any problems?
 - No: Continue to the next step.
 - Yes: A problem is identified
 - If you are a customer, record the error information, and then contact your service provider.
 - If you are an authorized service provider, return to map 210-5.

36. Press the F10 key to exit the diagnostic program.

Replacing a PCI adapter contained in a cassette from the expansion unit with the power on in IBM i:

You can replace a PCI adapter cassette from the 5802 or 5877 expansion unit that is running the IBM i operating system with the system power on.

You must have already completed the procedure “Removing a PCI adapter contained in a cassette from the expansion unit with the power on in IBM i” on page 41 to have the slot powered off.

To replace an adapter, do the following steps:

1. If the adapter needs to be placed in the PCI adapter cassette, see “PCI adapter single-width and double-width cassettes” on page 46.
2. At the back of the system, lift the cassette cover flap and identify the cassette slot you want to use.
3. Install the PCI adapter cassette in the system. Refer to “Installing a PCI adapter contained in a cassette” on page 34.
4. Select **Power on domain** on the Hardware Resource Concurrent Maintenance display and press Enter.
5. Select **Assign to** on the resource that has an asterisk (*) on the Work with Controlling Resource display. Press Enter.
6. Wait for the Hardware Resource Concurrent Maintenance display to appear with this message:
Power on complete
7. Verify that the new resource is functional. See Verify the installed part.

Replacing a PCI adapter contained in a cassette from the expansion unit with the power on in Linux:

You can replace a PCI adapter cassette from the 5802 or 5877 expansion unit that is running the Linux operating system with the system power on.

You must have already completed the procedure “Removing a PCI adapter contained in a cassette from the expansion unit with the power on in Linux” on page 42 to have the slot powered off.

Note: Use this procedure only when you are replacing an adapter with an identical adapter. If you are replacing an adapter with an adapter that is not identical to the adapter removed, follow the steps in “Installing a PCI adapter contained in a cassette with the power on in the Linux environment” on page 37.

To replace an adapter with the power on in Linux, do the following steps:

1. If the adapter needs to be placed in the PCI adapter cassette, see “PCI adapter single-width and double-width cassettes” on page 46.
2. At the back of the system, lift the cassette cover flap and identify the cassette slot you want to use.
3. Ensure the lower cassette handle is pressed up toward the retainer clip. This places the adapter in the correct position to be docked in the system.
4. Run the `drslot_chrp_pci` command to enable an adapter to be replaced:

For example, to replace the PCI adapter in slot U7879.001.DQD014E-P1-C3 run this command:

```
drslot_chrp_pci -R -s U7879.001.DQD014E-P1-C3
```

5. Follow the instructions on the display to complete the task. When you are instructed to insert the adapter in the adapter slot, see “Installing a PCI adapter cassette” on page 35.
6. Run the lsslot command to verify that the slot is occupied.

For example, Enter `lsslot -c pci -s U7879.001.DQD014E-P1-C3`

The following is an example of the information displayed by this command:

Slot	Description	Devices
U7879.001.DQD014E-P1-C3	PCI-X capable, 64 bit, 133MHz slot	0001:40:01.0

PCI adapter single-width and double-width cassettes

You can remove, replace, or install PCI adapters in a cassette.

Removing an adapter from the PCI adapter single-width cassette:

You can remove a PCI adapter from a single-width cassette.

To remove an adapter from the single-width cassette, do the following steps:

1. Perform the prerequisite tasks described in “Before you begin” on page 63.
2. Take appropriate precautions for avoiding electric shock and handling static-sensitive devices. For information, see “Safety notices” on page v and “Handling static-sensitive devices” on page 67.
3. Remove the cassette from the system.
4. Remove the cassette cover by doing the following steps:
 - a. Slide the cover latch (A) to disengage the lug and pivot pin (C) as shown in the following figure.
 - b. Lift the cover (B) off the pivot pin.
 - c. Slide the cover off the cassette.

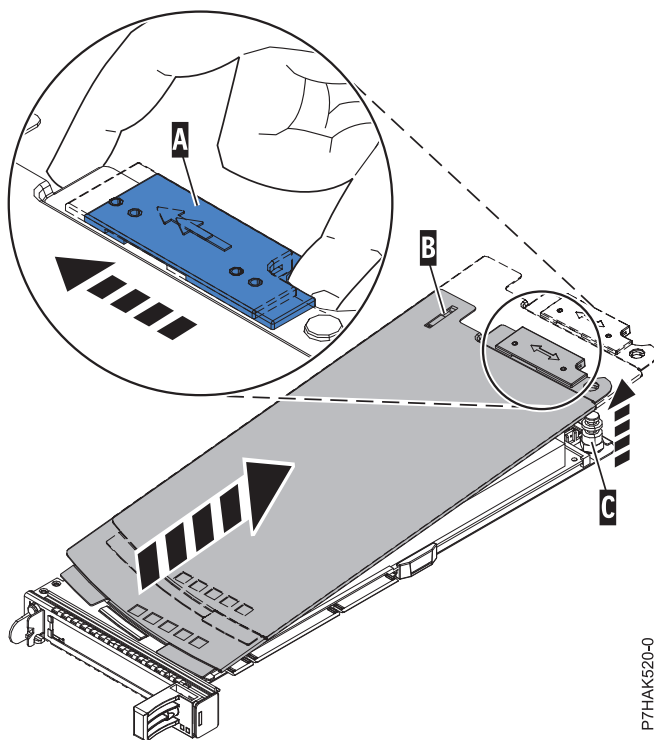

P7HAK520-0

Figure 35. PCI adapter cassette cover removed

5. Remove the adapter from the cassette by doing the following steps:

- a. Unlock the adapter retainers by rotating the retainer clip (A) into the horizontal position. See Figure 36.

Notes:

- 1) The edge of the adapter located at the end of the cassette that contains the cassette handles is called the adapter **tailstock**.
 - 2) Two retainers are located at the top of the cassette, along the top edge of the adapter. Two more retainers are located at the edge of the cassette opposite of the adapter tailstock.
 - 3) When the retainer clip is in the horizontal position, the adapter retainers are unlocked and can slide away from the card.
 - 4) If the corner support retainer is used, unlock it, and then slide the corner support retainer away from the card.
- b. Push the adapter retainers (B) away from the adapter.
 - c. Unlock the adapter tailstock clamp (C).
 - d. Rotate the adapter out of the cassette by grasping the edge of the adapter opposite the tailstock, and then firmly rotate the adapter toward the bottom of the cassette.
 - e. Lift the adapter out of the tailstock retaining channel.

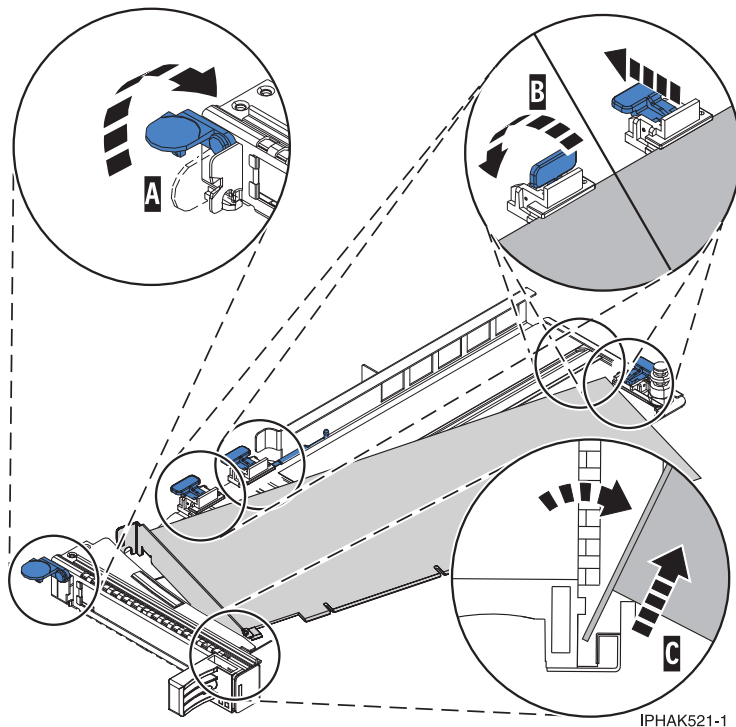
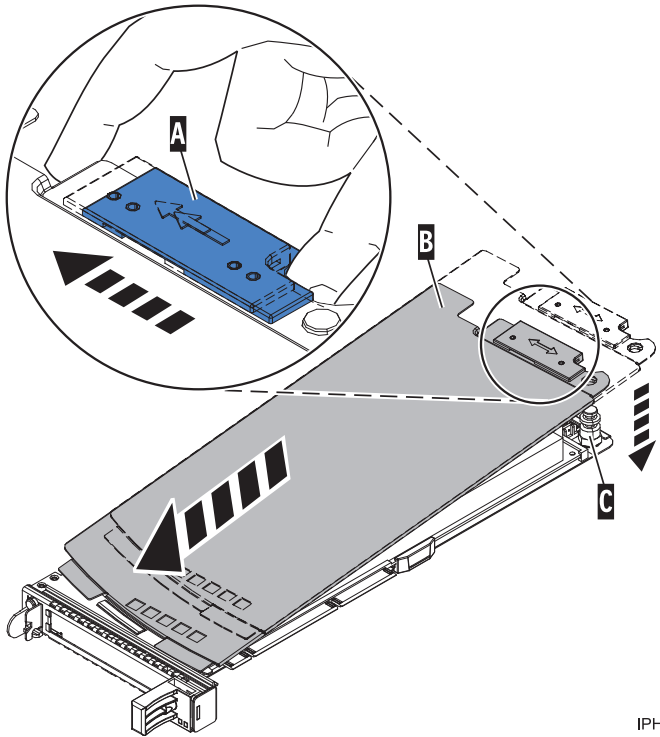

Figure 36. Adapter removed from the PCI adapter cassette

- f. Put the adapter in a safe place.
Attention: A cassette containing either a PCI adapter or filler panel must be placed in the PCI adapter slot of the system unit for proper air flow and cooling.
- g. Place a PCI adapter or filler panel in the cassette. See “Placing a PCI adapter in a single-width cassette” on page 48.
- h. Replace the cassette cover by doing the following steps:
 - 1) Slide the cover (B) into position on the cassette.
 - 2) While holding the cover latch (A) in the open position, place the cover over the pivot pin (C).

3) Release the cover latch to lock the cover into place.



IPHAK530-0

Figure 37. PCI adapter cassette cover replaced

Placing a PCI adapter in a single-width cassette:

You can place a PCI adapter in a single-width cassette.

To place a PCI adapter in a cassette, do the following steps:

1. Perform the prerequisite tasks described in “Before you begin” on page 63.
2. Take appropriate precautions for avoiding electric shock and handling static-sensitive devices. For information, see “Safety notices” on page v and “Handling static-sensitive devices” on page 67.
3. Remove any shipping handles or brackets attached to the adapter.
4. Remove the cassette cover by doing the following steps:
 - a. Slide the cover latch (A) to disengage the lug and pivot pin (C) as shown in the following figure.
 - b. Lift the cover (B) off of the pivot pin.
 - c. Slide the cover off of the cassette.

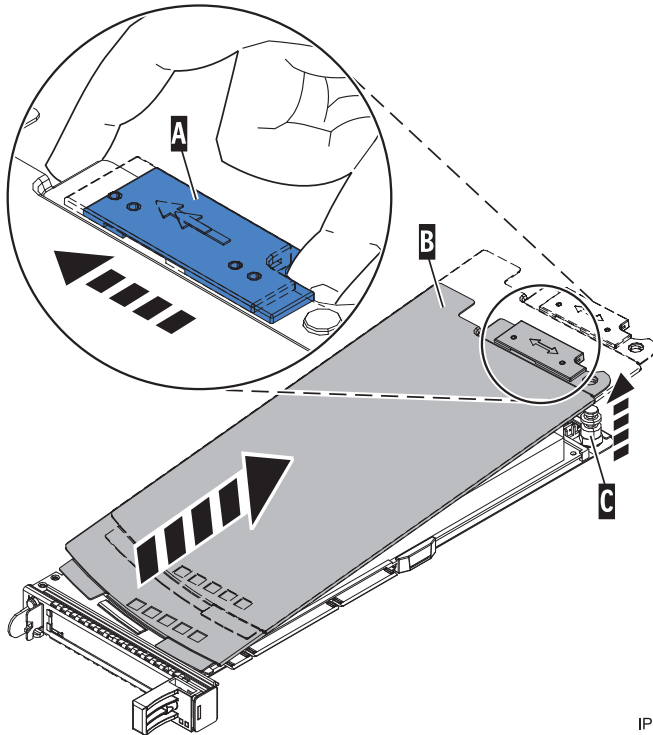

IPHAK520-0

Figure 38. PCI adapter single-width cassette cover removed

5. Ensure the cassette is prepared to receive an adapter by doing the following steps:
 - a. Ensure the cassette is empty by doing one of the following steps:
 - “Removing an adapter from the PCI adapter single-width cassette” on page 46.
 - Remove the adapter filler panel from the cassette.
 - b. Ensure that all of the adapter retainers (A) have been pushed out to the edges of the cassette to allow the placement of the adapter. See Figure 39 on page 50.

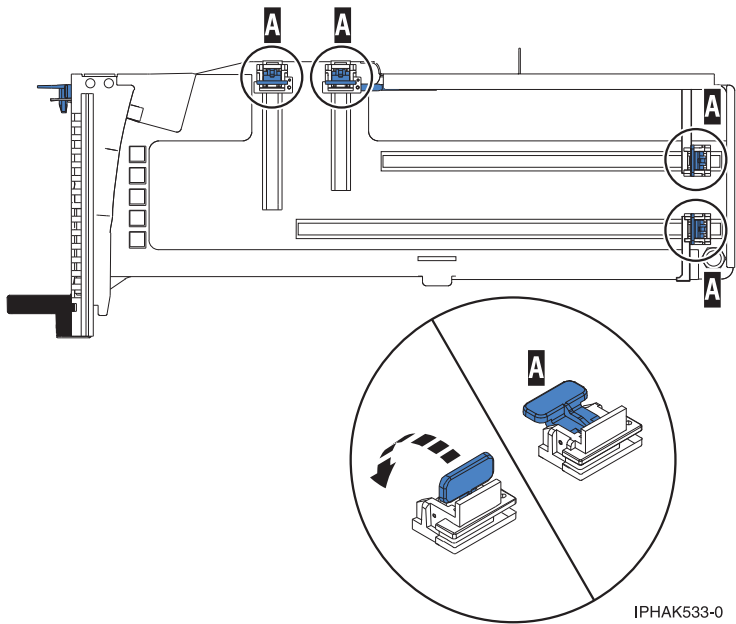

Figure 39. Adapter retainers

- c. Rotate the tailstock clamp into the open position.

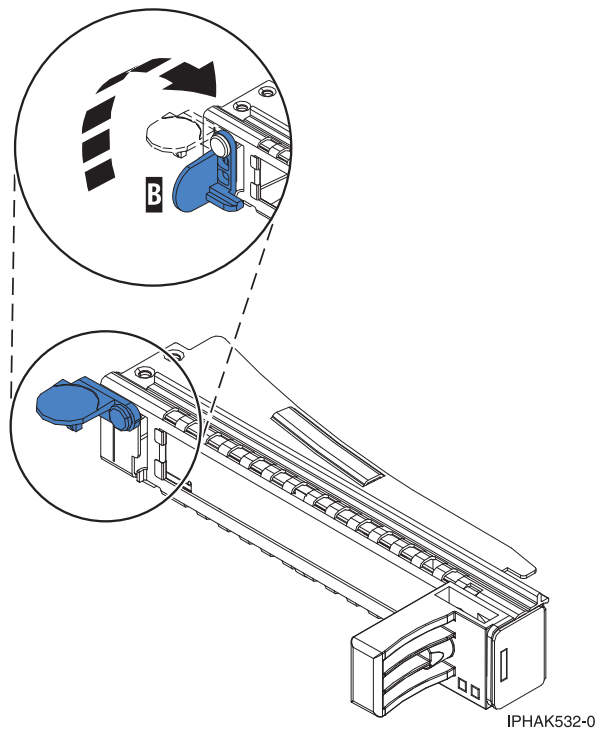
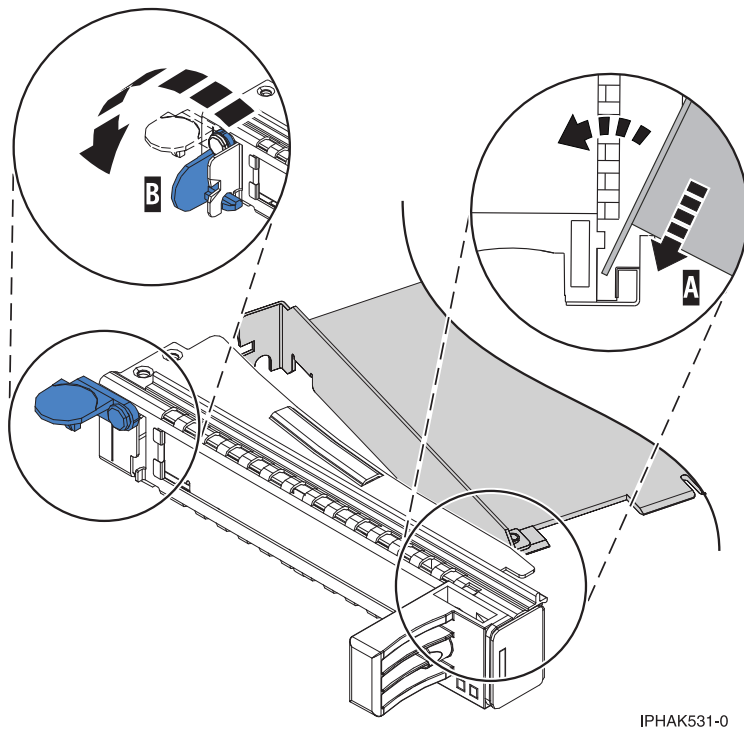

Figure 40. Tailstock clamp in the open position

6. Place the adapter in the cassette by doing the following steps:
 - a. With the tailstock clamp in the open position, insert the adapter firmly into the tailstock retaining channel (A). See Figure 41 on page 51.
 - b. Rotate the adapter toward the top of the cassette and into place.

c. Close the tailstock clamp (B). See Figure 41.



IPHAK531-0

Figure 41. Adapter removed from the PCI adapter single-width cassette

d. Position the adapter retainers to support the adapter, and then rotate the retainer clip into the closed position.

Notes:

- 1) Two retainers are located at the top of the cassette, along the top edge of the adapter. Two more retainers are located at the edge of the cassette opposite of the adapter tailstock.
- 2) When the adapter retainer clip is in the horizontal position, the adapter retainers are unlocked and can slide toward the adapter.
- 3) Place the retainers on the adapter according to the length of the adapter being used. Select the appropriate instructions:

Adapter-cassette retainer placement for large adapters

- a) Place and lock the retainers (B). See Figure 42 on page 52.

Attention: Use of the lower corner support retainer might interfere with the docking of the PCI card when positioned within the system. Ensure the retainer does not interfere with the adapter connectors on the system backplane.

- b) Ensure the adapter edge is seated in each retainer groove (A). If the shape of the adapter or the presence of a connector will not allow the adapter edge to be seated into the retainer groove, ensure the retainer is still locked firmly against that edge or connector.

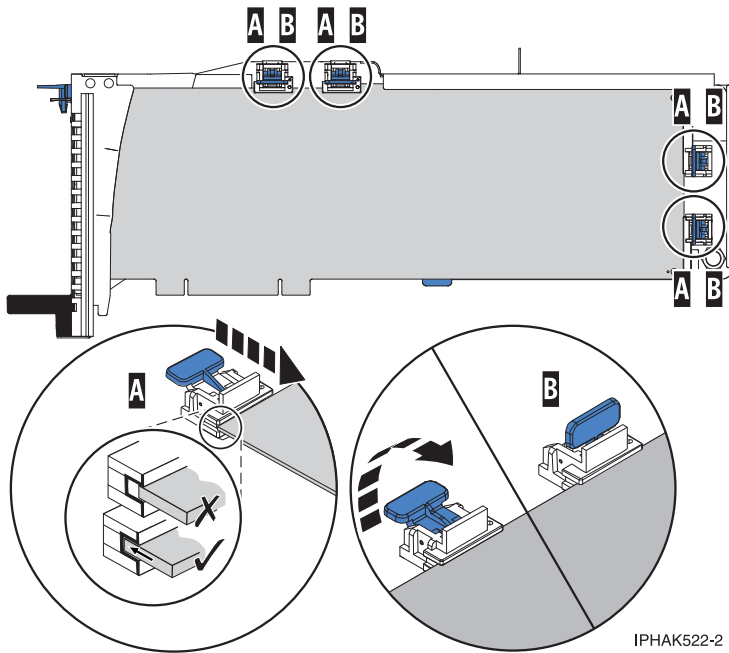
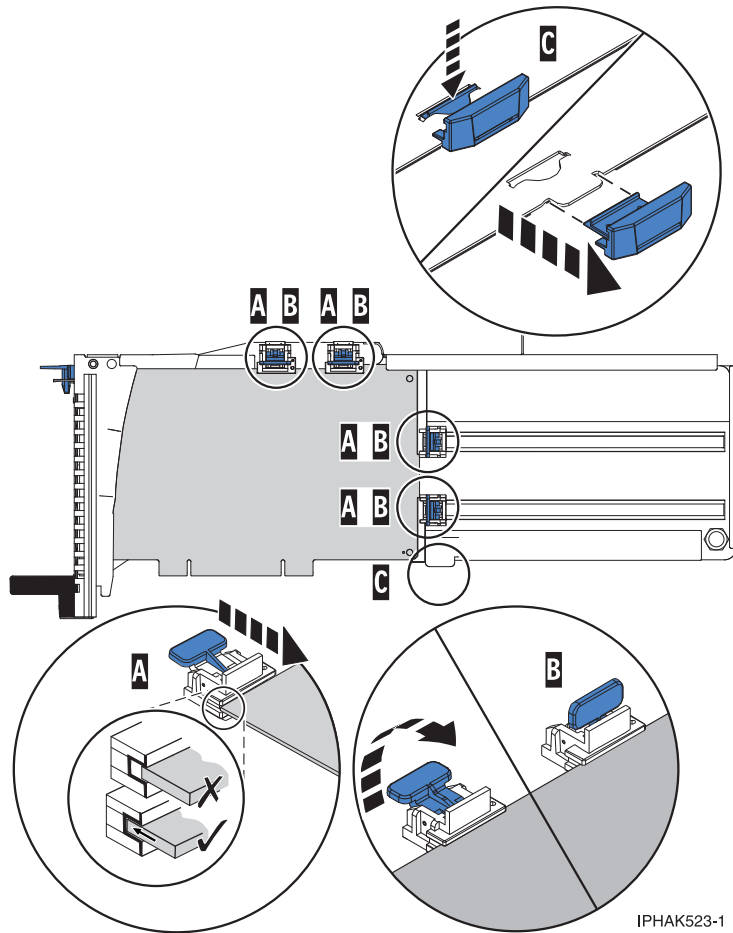

Figure 42. Large adapter in the PCI adapter cassette with the supports and stabilizer in place

Adapter-cassette retainer placement for medium-length adapters

- a) Remove the adapter stabilizer (C). See Figure 43 on page 53.
- b) Place and lock the retainers (B).
- c) Ensure the adapter edge is seated in each retainer groove (A). If the shape of the adapter or the presence of a connector will not allow the adapter edge to be seated into the retainer groove, ensure the retainer is still locked firmly against that edge or connector.



IPHAK523-1

Figure 43. Medium-length adapter in the PCI adapter cassette with the supports in place

Adapter-cassette retainer placement for small adapters

- a) Remove the adapter stabilizer (C). See Figure 44 on page 54.
- b) Place the hookarm (D) into the hole in the corner of the adapter. This supports the card when it is undocked from the connector on the system backplane.
- c) Place and lock the retainers (B).
- d) Ensure the adapter edge is seated in each retainer groove (A). If the shape of the adapter or the presence of a connector will not allow the adapter edge to be seated into the retainer groove, ensure the retainer is still locked firmly against that edge or connector.

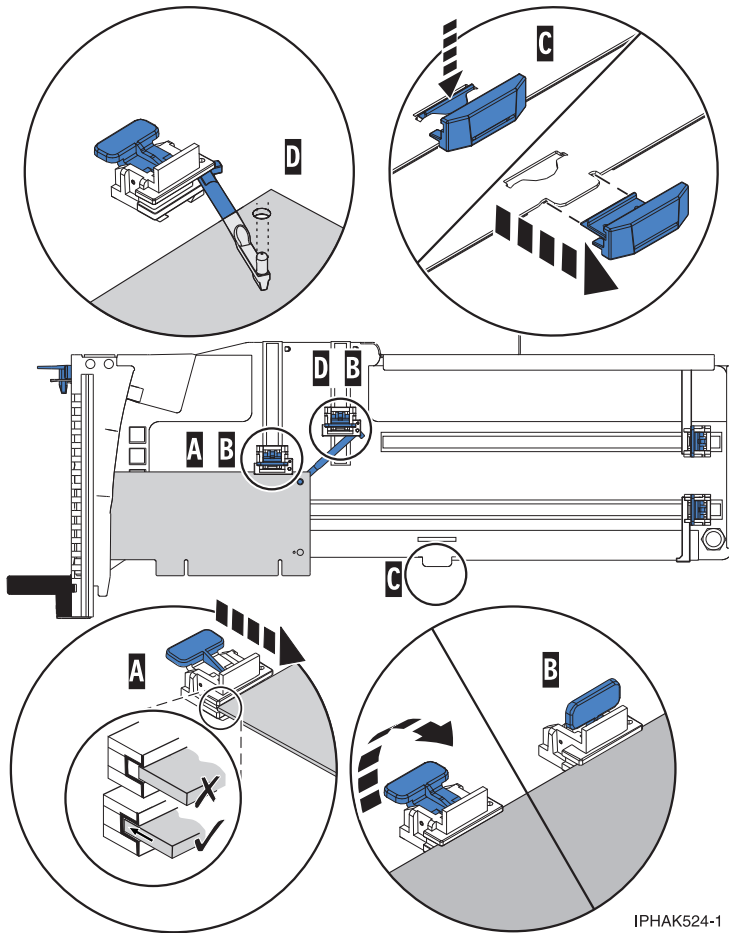

IPHA524-1

Figure 44. Small adapter in the PCI adapter cassette with the supports and the hookarm in place

7. Replace the cassette cover by doing the following steps:
 - a. Slide the cover (B) into position on the cassette as shown in the following figure.
 - b. While holding the cover latch (A) in the open position, place the cover over the pivot pin (C).
 - c. Release the cover latch to lock the cover into place.

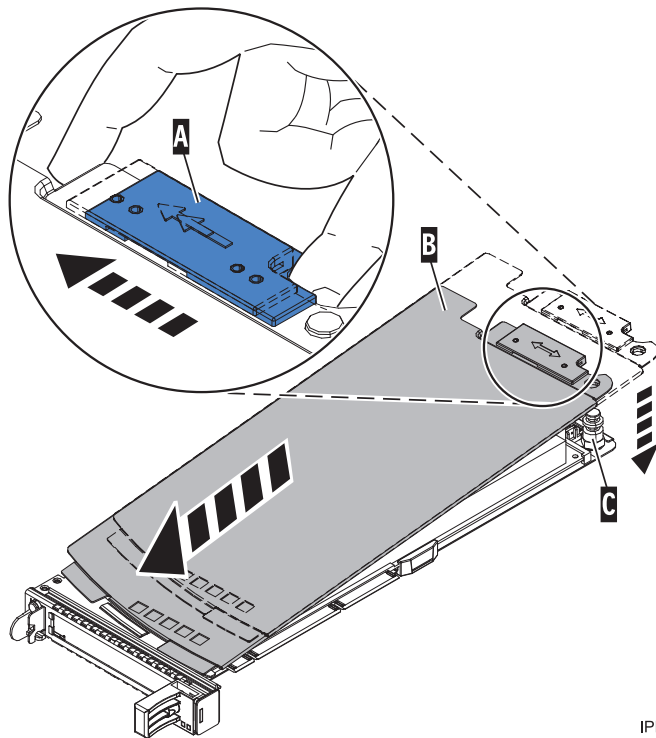

IPHAK530-0

Figure 45. PCI adapter cassette cover replaced

Removing an adapter from the PCI adapter double-wide cassette:

You can remove a PCI adapter from a double-wide cassette.

To remove an adapter from the cassette, do the following steps:

1. Perform the prerequisite tasks described in “Before you begin” on page 63.
2. Take appropriate precautions for avoiding electric shock and handling static-sensitive devices. For information, see “Safety notices” on page v and “Handling static-sensitive devices” on page 67.
3. Remove the PCI adapter contained in a cassette from the system.
4. Remove any shipping handles or brackets attached to the adapter.
5. Remove the cassette cover by doing the following steps:
 - a. Slide the cover latch (A) to disengage it from the pivot pin (C) as shown in the following figure.
 - b. Lift the cover (B) off of the pivot pin.
 - c. Slide the cover off of the cassette.

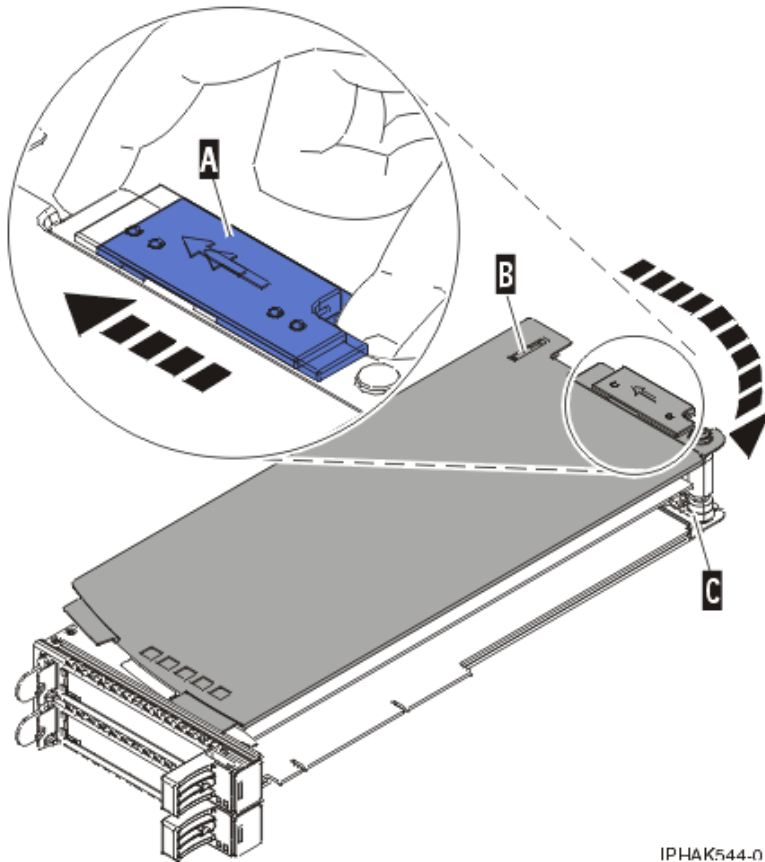

IPHAK544-0

Figure 46. PCI adapter cassette cover removed

- d. Unscrew pivot pin (C) and put it in a safe place
6. Remove the adapter from the cassette by doing the following steps:

Note: If you are removing a PCIe RAID and SSD SAS adapter, see Figure 48 on page 57.

- a. Unlock the adapter retainers (B) by rotating the retainer clips (A) into the horizontal position. See Figure 47 on page 57. If you are removing a PCIe RAID and SSD SAS adapter, see Figure 48 on page 57.

Notes:

- 1) The edge of the adapter located at the end of the cassette that contains the cassette handles is called the adapter *tailstock*.
 - 2) Two retainers are located at the top of the cassette, along the top edge of the adapter. Two more retainers are located at the edge of the cassette opposite of the adapter tailstock.
 - 3) When the retainer clip is in the horizontal position, the adapter retainers are unlocked and can slide away from the card.
 - 4) If the corner support retainer is used, unlock it, and then slide the corner support retainer away from the card.
- b. Push the adapter retainers (B) away from the adapter.
 - c. Unlock the adapter tailstock clamp (A).
 - d. Rotate the adapter out of the cassette by grasping the edge of the adapter opposite the tailstock, and then firmly rotate the adapter toward the bottom of the cassette.
 - e. Lift the adapter out of the tailstock retaining channel (C).

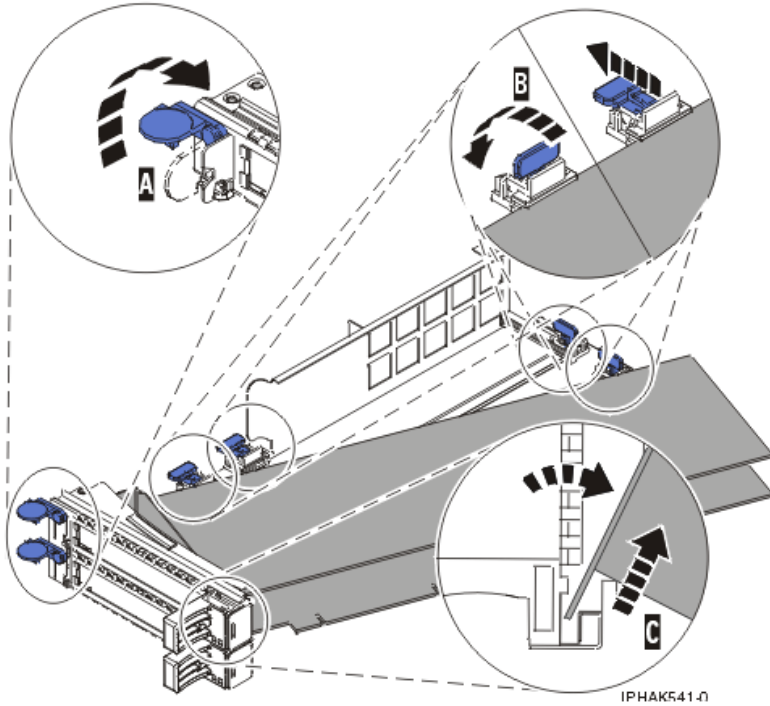

Figure 47. Adapter removed from the PCI adapter cassette

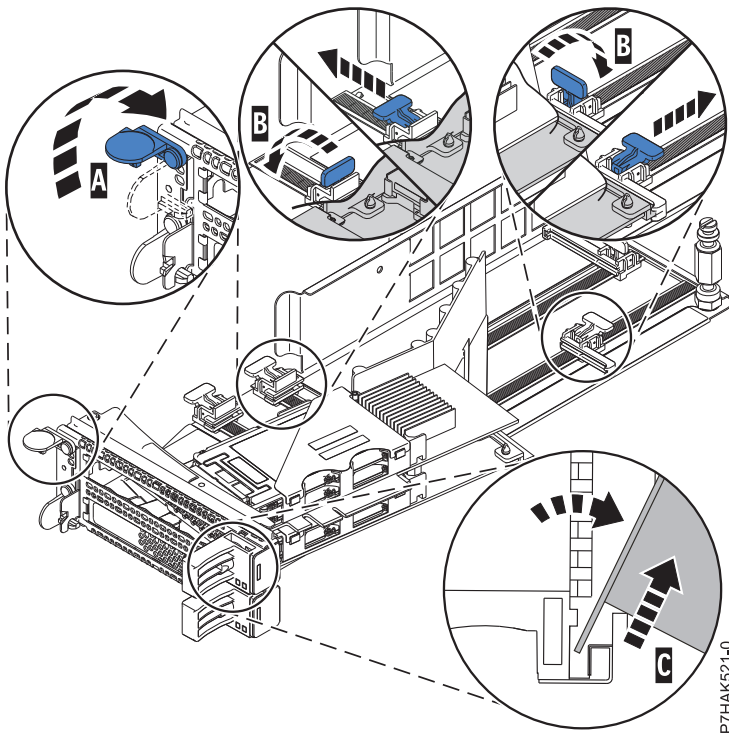

Figure 48. PCIe RAID and SSD SAS adapter removed from the PCI adapter cassette

- f. Put the adapter in a safe place.

Attention: A cassette containing either a PCI adapter or filler panel must be placed in the PCI adapter slot of the system unit for proper air flow and cooling.

- g. Place the adapter in the PCI adapter double-wide cassette. For information, see “Placing an adapter in the PCI adapter double-wide cassette.”

Note: If the cassette is not going to contain a PCI adapter, use this same procedure to place an adapter filler panel in the cassette.

- h. Replace the cassette cover by doing the following steps:
 - 1) Screw pivot pin (C) into place.
 - 2) Slide the cover (B) into position on the cassette.
 - 3) While holding the cover latch (A) in the open position, place the cover over the pivot pin (C).
 - 4) Release the cover latch to lock the cover into place.

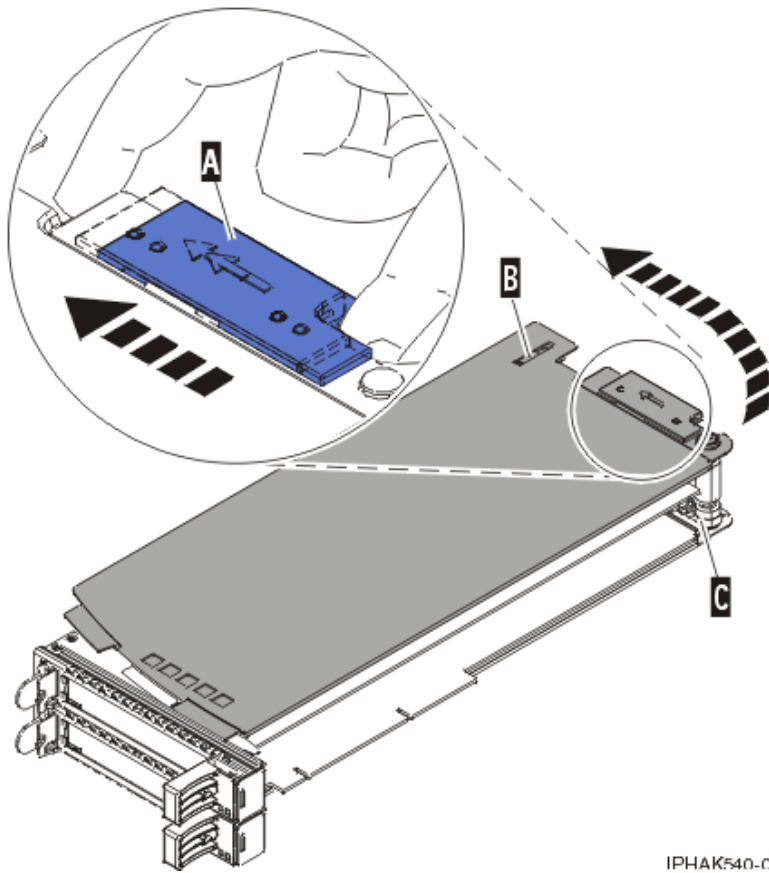

Figure 49. PCI adapter cassette cover replaced

Placing an adapter in the PCI adapter double-wide cassette:

You can place a PCI adapter in a double-wide cassette.

To place an adapter in a cassette, do the following steps:

1. Perform the prerequisite tasks described in “Before you begin” on page 63.
2. Remove the PCI adapter contained in a cassette from the system.
3. Remove the cassette cover by doing the following steps:
 - a. Slide the cover latch (A) to disengage it from the pivot pin (C) as shown in the following figure.
 - b. Lift the cover (B) off of the pivot pin.
 - c. Slide the cover off of the cassette.

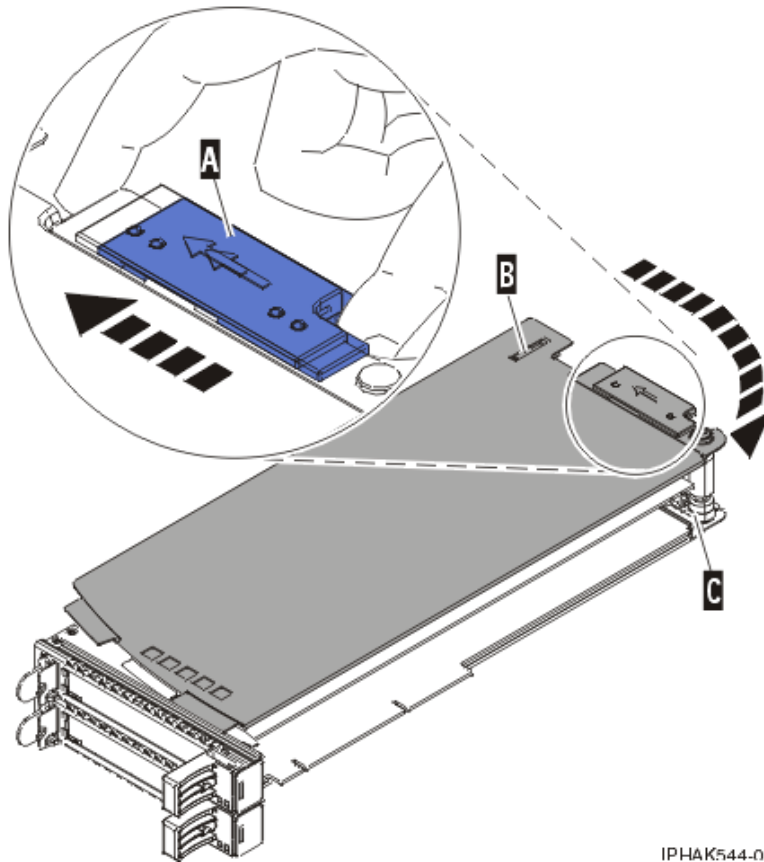

IPHAK544-0

Figure 50. PCI adapter cassette cover removed

- d. Unscrew pivot pin (C) and put it in a safe place.
4. Ensure the cassette is prepared to receive an adapter by doing the following steps:
 - a. Ensure the cassette is empty by doing one of the following steps:
 - Remove the adapter from the PCI adapter double-wide cassette. For information, see “Removing an adapter from the PCI adapter double-wide cassette” on page 55.
 - Remove the adapter filler panel from the cassette.
 - b. Ensure that all of the adapter retainers have been pushed out to the edges of the cassette to allow the placement of the adapter.
 - c. Place the tailstock clamp in the open position by pressing the cassette handle towards the retainer clip.
5. If necessary, remove the new adapter from the antistatic package.

Attention: Avoid touching the components and gold connectors on the adapter.

6. Place the new adapter, component-side up, on a flat, static-protective surface.
7. For PCIe RAID and SSD SAS adapters, install the new air dam onto the new adapter.
 - a. Slide the air dam (A) between the two cards and align the three holes in the air dam with the three holes on the card edges. See the following figure.
 - b. Insert the three plastic rivets (B) into the card and air dam holes.
 - c. Insert the three plastic push pins (C) into the three plastic rivets.
 - d. Label the location of each solid state disk (SSD) as you transfer the SSDs from the replaced adapter to the same location on the new adapter you are installing. For information about replacing SSDs, see Replacing an SSD module on the PCIe RAID and SSD SAS adapter. Repeat this step for each SSD.

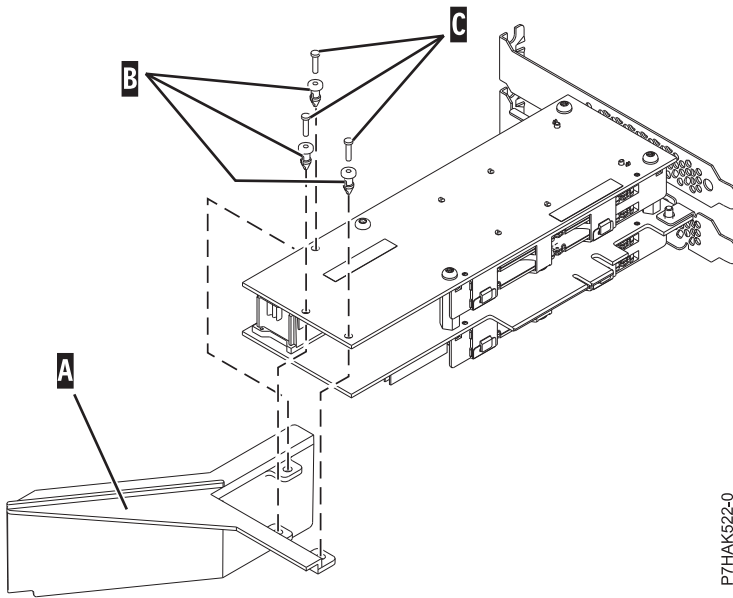

P7HAK522-0

Figure 51. Installing an air dam onto the new PCIe RAID and SSD SAS adapter

8. Place the adapter in the cassette by doing the following steps:
 - a. With the tailstock clamp in the open position, insert the adapter firmly into the tailstock retaining channel (A). For a typical PCI adapter, see Figure 52 on page 61. For a PCIe RAID and SSD SAS adapter, see Figure 53 on page 61.
 - b. Rotate the adapter toward the top of the cassette and into place.
 - c. Close the tailstock clamp (C).

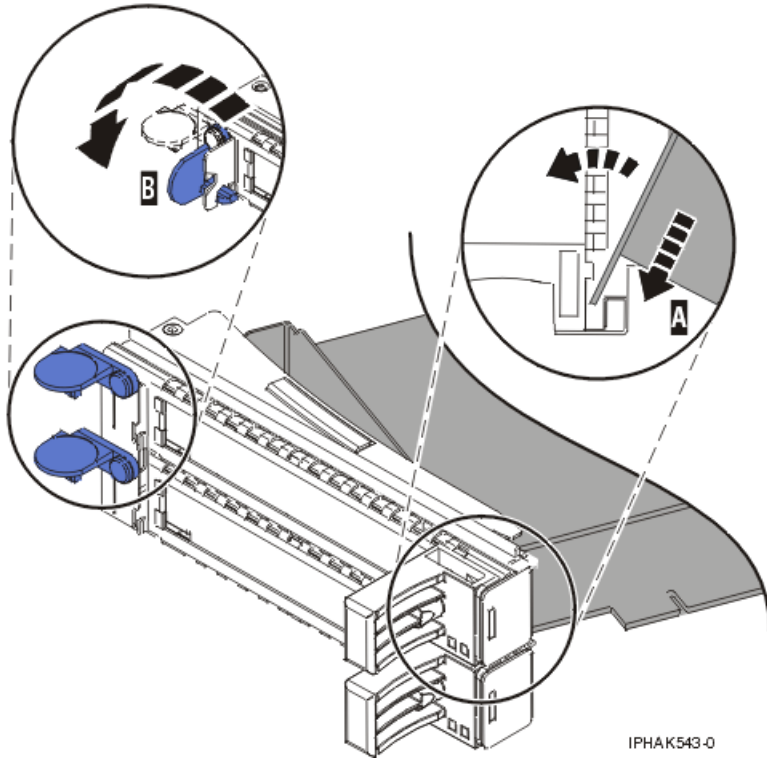

IPHAK543-0

Figure 52. Adapter replaced in the PCI adapter cassette

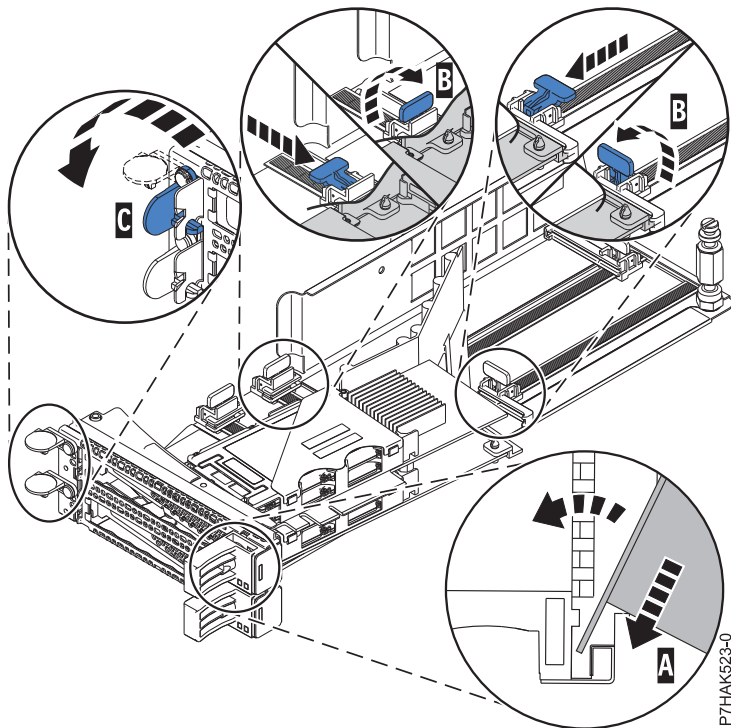

P7HAK523-0

Figure 53. Replacing a PCIe RAID and SSD SAS adapter into the PCI adapter cassette

- d. Position the adapter retainers to support the adapter, and then rotate the retainer clip **(B)** into the closed position.

Notes:

- 1) Two retainers are located at the top of the cassette, along the top edge of the adapter. Two more retainers are located at the edge of the cassette opposite of the adapter tailstock.
- 2) When the adapter retainer clip is in the horizontal position, the adapter retainers are unlocked and can slide toward the adapter.
- 3) Place and lock the retainers (**B**). See Figure 54.

Attention: Use of the lower corner support retainer might interfere with the docking of the PCI card when positioned within the system. Ensure the retainer does not interfere with the adapter connectors on the system backplane.

- 4) Ensure the adapter edge is seated in each retainer groove (**A**). If the shape of the adapter or the presence of a connector will not allow the adapter edge to be seated into the retainer groove, ensure the retainer is still locked firmly against that edge or connector.

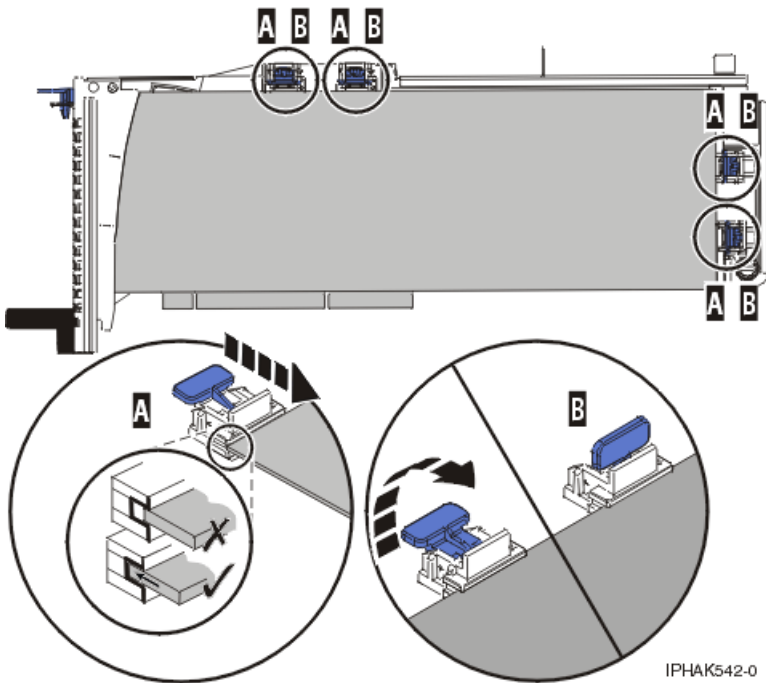

Figure 54. Long adapter in the PCI adapter cassette with the supports and stabilizer in place

9. After the retainers are placed, replace the cassette cover by doing the following steps:
 - a. Screw pivot pin (**C**) into place.
 - b. Slide the cover (**B**) into position on the cassette as shown in the following figure.
 - c. While holding the cover latch (**A**) in the open position, place the cover over the pivot pin (**C**).
 - d. Release the cover latch to lock the cover into place.

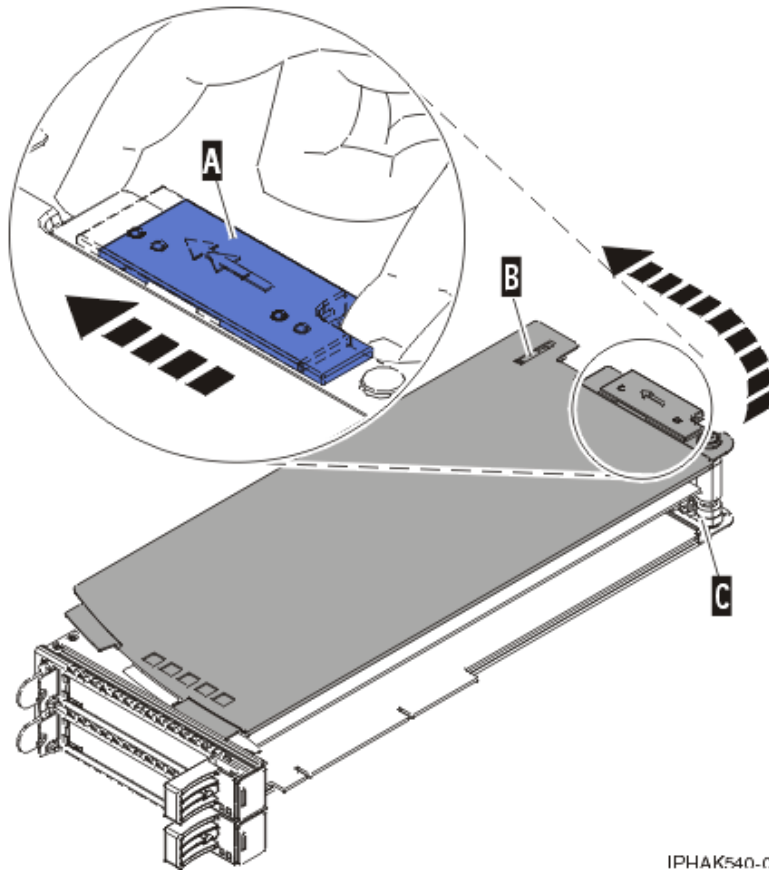

Figure 55. PCI adapter cassette cover replaced

10. Replace the PCI adapter contained in a cassette in the system.

Attention: A cassette containing either a PCI adapter or filler panel must be placed in the PCI adapter slot of the system unit for proper air flow and cooling.

Related procedures for installing and removing PCI adapters

These procedures are related to installing and removing PCI adapters.

Before you begin:

Observe these precautions when you are installing, removing, or replacing features and parts.

These precautions are intended to create a safe environment to service your system and do not provide steps for servicing your system. The installation, removal and replacement procedures provide the step-by-step processes required to service your system.

DANGER

When working on or around the system, observe the following precautions:

Electrical voltage and current from power, telephone, and communication cables are hazardous. To avoid a shock hazard:

- Connect power to this unit only with the IBM provided power cord. Do not use the IBM provided power cord for any other product.
- Do not open or service any power supply assembly.
- Do not connect or disconnect any cables or perform installation, maintenance, or reconfiguration of this product during an electrical storm.
- The product might be equipped with multiple power cords. To remove all hazardous voltages, disconnect all power cords.
- Connect all power cords to a properly wired and grounded electrical outlet. Ensure that the outlet supplies proper voltage and phase rotation according to the system rating plate.
- Connect any equipment that will be attached to this product to properly wired outlets.
- When possible, use one hand only to connect or disconnect signal cables.
- Never turn on any equipment when there is evidence of fire, water, or structural damage.
- Disconnect the attached power cords, telecommunications systems, networks, and modems before you open the device covers, unless instructed otherwise in the installation and configuration procedures.
- Connect and disconnect cables as described in the following procedures when installing, moving, or opening covers on this product or attached devices.

To Disconnect:

1. Turn off everything (unless instructed otherwise).
2. Remove the power cords from the outlets.
3. Remove the signal cables from the connectors.
4. Remove all cables from the devices

To Connect:

1. Turn off everything (unless instructed otherwise).
2. Attach all cables to the devices.
3. Attach the signal cables to the connectors.
4. Attach the power cords to the outlets.
5. Turn on the devices.

(D005)

DANGER

Observe the following precautions when working on or around your IT rack system:

- Heavy equipment—personal injury or equipment damage might result if mishandled.
- Always lower the leveling pads on the rack cabinet.
- Always install stabilizer brackets on the rack cabinet.
- To avoid hazardous conditions due to uneven mechanical loading, always install the heaviest devices in the bottom of the rack cabinet. Always install servers and optional devices starting from the bottom of the rack cabinet.
- Rack-mounted devices are not to be used as shelves or work spaces. Do not place objects on top of rack-mounted devices.



- Each rack cabinet might have more than one power cord. Be sure to disconnect all power cords in the rack cabinet when directed to disconnect power during servicing.
- Connect all devices installed in a rack cabinet to power devices installed in the same rack cabinet. Do not plug a power cord from a device installed in one rack cabinet into a power device installed in a different rack cabinet.
- An electrical outlet that is not correctly wired could place hazardous voltage on the metal parts of the system or the devices that attach to the system. It is the responsibility of the customer to ensure that the outlet is correctly wired and grounded to prevent an electrical shock.

CAUTION

- Do not install a unit in a rack where the internal rack ambient temperatures will exceed the manufacturer's recommended ambient temperature for all your rack-mounted devices.
- Do not install a unit in a rack where the air flow is compromised. Ensure that air flow is not blocked or reduced on any side, front, or back of a unit used for air flow through the unit.
- Consideration should be given to the connection of the equipment to the supply circuit so that overloading of the circuits does not compromise the supply wiring or overcurrent protection. To provide the correct power connection to a rack, refer to the rating labels located on the equipment in the rack to determine the total power requirement of the supply circuit.
- *(For sliding drawers.)* Do not pull out or install any drawer or feature if the rack stabilizer brackets are not attached to the rack. Do not pull out more than one drawer at a time. The rack might become unstable if you pull out more than one drawer at a time.
- *(For fixed drawers.)* This drawer is a fixed drawer and must not be moved for servicing unless specified by the manufacturer. Attempting to move the drawer partially or completely out of the rack might cause the rack to become unstable or cause the drawer to fall out of the rack.

(R001)

Before you begin a replacement or installation procedure, perform these tasks:

1. If you are installing a new feature, ensure that you have the software required to support the new feature.
To do this, go to the following Web site: IBM Prerequisite
2. If you are performing an installation or replacement procedure that might put your data at risk, ensure, wherever possible, that you have a current backup of your system or logical partition (including operating systems, licensed programs, and data).
3. Review the installation or replacement procedure for the feature or part.
4. Note the significance of color on your system.

Blue or terra-cotta on a part of the hardware indicates a touch point where you can grip the hardware to remove it from or install it in the system, open or close a latch, and so on. Terra-cotta might also indicate that the part can be removed and replaced with the system or logical partition power on.

5. Ensure that you have access to a medium flat-blade screwdriver, a Phillips screwdriver, and a pair of scissors.
6. If parts are incorrect, missing, or visibly damaged, do the following:
 - If you are replacing a part, contact the provider of your parts or next level of support.
 - If you are installing a feature, contact one of the following service organizations:
 - The provider of your parts or next level of support.
 - In the United States, the IBM Rochester Manufacturing Automated Information Line (R-MAIL) at 1-800-300-8751.

In countries and regions outside of the United States, use the following Web site to locate your service and support telephone numbers:

<http://www.ibm.com/planetwide>

7. If you encounter difficulties during the installation, contact your service provider, your IBM reseller, or your next level of support.
8. If you are installing new hardware in a logical partition, you need to understand and plan for the implications of partitioning your system. For information, see Logical Partitioning.

Avoiding electric shock:

Learn about precautions you should take to avoid electric shock when working on our around a computer system.

DANGER

When working on or around the system, observe the following precautions:

Electrical voltage and current from power, telephone, and communication cables are hazardous. To avoid a shock hazard:

- Connect power to this unit only with the IBM provided power cord. Do not use the IBM provided power cord for any other product.
- Do not open or service any power supply assembly.
- Do not connect or disconnect any cables or perform installation, maintenance, or reconfiguration of this product during an electrical storm.
- The product might be equipped with multiple power cords. To remove all hazardous voltages, disconnect all power cords.
- Connect all power cords to a properly wired and grounded electrical outlet. Ensure that the outlet supplies proper voltage and phase rotation according to the system rating plate.
- Connect any equipment that will be attached to this product to properly wired outlets.
- When possible, use one hand only to connect or disconnect signal cables.
- Never turn on any equipment when there is evidence of fire, water, or structural damage.
- Disconnect the attached power cords, telecommunications systems, networks, and modems before you open the device covers, unless instructed otherwise in the installation and configuration procedures.
- Connect and disconnect cables as described in the following procedures when installing, moving, or opening covers on this product or attached devices.

To Disconnect:

1. Turn off everything (unless instructed otherwise).
2. Remove the power cords from the outlets.
3. Remove the signal cables from the connectors.
4. Remove all cables from the devices

To Connect:

1. Turn off everything (unless instructed otherwise).
2. Attach all cables to the devices.
3. Attach the signal cables to the connectors.
4. Attach the power cords to the outlets.
5. Turn on the devices.

(D005)

Handling static-sensitive devices:

Learn about precautions you should take to prevent damage to electronic components from static electricity discharge.

Electronic boards, adapters, media drives, and disk drives are sensitive to static electricity discharge. These devices are wrapped in antistatic bags to prevent this damage. Take the following precautions to prevent damage to these devices from static electricity discharge.

- Attach a wrist strap to an unpainted metal surface of your hardware to prevent electrostatic discharge from damaging your hardware.
- When using a wrist strap, follow all electrical safety procedures. A wrist strap is for static control. It does not increase or decrease your risk of receiving electric shock when using or working on electrical equipment.
- If you do not have a wrist strap, just prior to removing the product from ESD packaging and installing or replacing hardware, touch an unpainted metal surface of the system for a minimum of 5 seconds.
- Do not remove the device from the antistatic bag until you are ready to install the device in the system.

- With the device still in its antistatic bag, touch it to the metal frame of the system.
- Grasp cards and boards by the edges. Avoid touching the components and gold connectors on the adapter.
- If you need to lay the device down while it is out of the antistatic bag, lay it on the antistatic bag. Before picking it up again, touch the antistatic bag and the metal frame of the system at the same time.
- Handle the devices carefully to prevent permanent damage.

PCI hot-plug manager access for AIX:

You might need to service PCI adapters with the system power on in AIX. Use the procedures in this section to perform this task.

The instructions for servicing PCI adapters with the system power on in AIX refer you to these procedures when it is appropriate to perform them.

Note: For an adapter to be serviced with the system power on, both the adapter and the system unit must support hot-plug procedures. To identify adapters that are hot-pluggable in the system you are servicing, refer to the following placement information: PCI adapter placement.

Accessing hot-plug management functions:

You can use PCI Hot Plug Manager to service PCI adapters with the system power on in AIX. Use the procedures in this section to perform this task.

Note: Procedures performed on a PCI adapter with the system power on in AIX, also known as hot-plug procedures, require the system administrator to take the PCI adapter offline prior to performing the operation. Before taking an adapter offline, the devices attached to the adapter must be taken offline as well. This action prevents a service representative or user from causing an unexpected outage for system users.

To access the hot-plug menus, do the following:

1. Log in as root user.
2. At the command line, type `smitty`.
3. Select **Devices**.
4. Select **PCI Hot Plug Manager** and press Enter.
5. The PCI Hot-Plug Manager menu displays. Return to the procedure that directed you here. The following section describes the menu options.

PCI hot-plug manager menu:

You can use PCI Hot Plug Manager to service PCI adapters with the system power on in AIX. The following options are available from the PCI Hot Plug Manager menu.

Note: For information about the PCI slot LED states, see “Component LEDs” on page 71.

List PCI hot-plug slots

Provides a descriptive list of all slots that support PCI hot-plug capability. If the listing for a slot indicates it holds an “Unknown” device, select the **Install/configure Devices added after IPL** to configure the adapter in that slot.

Add a PCI hot-plug adapter

Allows the user to add a new PCI hot-plug-capable adapter to the slot with the system turned on. You will be asked to identify the PCI slot that you have selected prior to the actual operation. The selected PCI slot will go into the Action state and finally into the On state.

Note: The system will indicate the slot holds an “Unknown” device until you perform the **Install/configure devices added after IPL** option to configure the adapter.

Replace/remove a PCI hot-plug adapter

Allows the user to remove an existing adapter, or replace an existing adapter with an identical one. For this option to work, the adapter must be in the Defined state (see the “Unconfigure a Device” option).

You will be asked to identify the PCI slot prior to the actual operation. The selected PCI slot will go into the Action state.

Identify a PCI hot-plug slot

Allows the user to identify a PCI slot. The selected PCI slot will go into the Identify state. See “Component LEDs” on page 71.

Unconfigure a device

Allows the user to put an existing PCI adapter into the Defined state if the device is no longer in use.

This step must be completed successfully before starting any removal or replacement operation. If this step fails, the customer must take action to release the device.

Configure a defined device

Allows a new PCI adapter to be configured into the system if software support is already available for the adapter. The selected PCI slot will go into the On state.

Install/configure devices added after IPL

The system attempts to configure any new devices and tries to find and install any required software from a user-selected source.

The add, remove, and replace functions return information to the user indicating whether the operation was successful. If additional instructions are provided on the screen, complete the recommended actions. If the instructions do not resolve the problem, do the following:

- If the adapter is listed as Unknown, perform the **Install/configure devices Added After IPL** option to configure the adapter.
- If you receive a warning indicating that needed device packages are not installed, the system administrator must install the specified packages before you can configure or diagnose the adapter.
- If you receive a failure message indicating a hardware error, the problem might be either the adapter or the PCI slot. Isolate the problem by retrying the operation in a different PCI slot, or trying a different adapter in the slot. If you determine that you have failing hardware, call your service representative.
- *Do not* use **Install/configure devices added after IPL** if your system is set up to run HACMP™ clustering. Consult with your system administrator or software support to determine the correct method to configure the replacement device.

Prerequisites for hot-plugging PCI adapters in Linux:

In the course of installing, removing, or replacing a PCI adapter with the system powered on in a Linux operating system, you might need to complete some prerequisite tasks. Use the information in this section to identify those prerequisites.

The Linux system administrator needs to take the PCI adapter offline prior to removing, replacing, or installing a PCI adapter with the system power on (hot-plugging). Before taking an adapter offline, the devices attached to the adapter must be taken offline as well. This action prevents a service representative or user from causing an unexpected outage for system users.

Before hot-plugging adapters for storage devices, ensure that the file systems on those devices are unmounted. After hot-plugging adapters for storage devices, ensure that the file systems on those devices are remounted.

Before hot-plugging an adapter, ensure that the server or partition is at the correct level of the Linux operating system (Linux 2.6 or later).

Install the POWER® Linux Service Aids. These service aids enable system serviceability, as well to improve system management.

If you are using a Linux on POWER distribution with Linux kernel version 2.6 or later, you can install the Service Aids that gives you access to more capabilities, which can help you diagnose problems on your system.

This software is available at the Service and productivity tools for Linux on POWER Web site (<http://www14.software.ibm.com/webapp/set2/sas/f/lopdiags/home.html>).

Verifying that the hot-plug PCI tools are installed for Linux:

In the course of installing, removing, or replacing a PCI adapter with the system power on in Linux operating system you might need use the hot-plug PCI tools. Use the procedure in this section to verify that you have the hot-plug PCI tools installed.

1. Enter the following command to verify that the hot-plug PCI tools are installed:

```
rpm -aq | grep rpa-pci-hotplug
```

If the command does not list any rpa-pci-hotplug packages, the PCI Hot Plug tools are not installed.

2. Enter the following command to ensure that the rpaphp driver is loaded:

```
ls -l /sys/bus/pci/slots/
```

The directory should contain data. If the directory is empty, the driver is not loaded or the system does not contain hot-plug PCI slots. The following is an example of the information displayed by this command:

```
drwxr-xr-x 15 root root 0 Feb 16 23:31 .
drwxr-xr-x  5 root root 0 Feb 16 23:31 ..
drwxr-xr-x  2 root root 0 Feb 16 23:31 0000:00:02.0
drwxr-xr-x  2 root root 0 Feb 16 23:31 0000:00:02.2
drwxr-xr-x  2 root root 0 Feb 16 23:31 0000:00:02.4
drwxr-xr-x  2 root root 0 Feb 16 23:31 0001:00:02.0
drwxr-xr-x  2 root root 0 Feb 16 23:31 0001:00:02.2
drwxr-xr-x  2 root root 0 Feb 16 23:31 0001:00:02.4
drwxr-xr-x  2 root root 0 Feb 16 23:31 0001:00:02.6
drwxr-xr-x  2 root root 0 Feb 16 23:31 0002:00:02.0
drwxr-xr-x  2 root root 0 Feb 16 23:31 0002:00:02.2
drwxr-xr-x  2 root root 0 Feb 16 23:31 0002:00:02.4
drwxr-xr-x  2 root root 0 Feb 16 23:31 0002:00:02.6
```

If the directory does not exist, run the following command to mount the filesystem:

```
mount -t sysfs sysfs /sys
```

3. Ensure the following tools are available in the /usr/sbin directory.
 - lsslot
 - drslot_chrp_pci
4. Return to the procedure that sent you here.

Component LEDs:

Individual LEDs are located on or near the failing components. Use the information in this section to interpret the LEDs.

The LEDs are located either on the component itself or on the carrier of the component (for example, memory card, fan, memory module, or processor). LEDs are either green or amber.

Green LEDs indicate either of the following:

- Electrical power is present.
- Activity is occurring on a link. (The system could be sending or receiving information.)

Amber LEDs indicate a fault or identify condition. If your system or one of the components on your system has an amber LED turned on or blinking, identify the problem and take the appropriate action to restore the system to normal.

Power supply and fan (CRU)

Use this procedure to install and remove the power supply and fan.

Removing a power supply or fan with power on

If your system is managed by the Hardware Management Console (HMC), use the HMC to remove a power supply. For instructions, see *Removing a part by using the Hardware Management Console*.

If your system is managed by the IBM Systems Director Management Console (SDMC), use the SDMC to remove a power supply in the server. For instructions, see *Removing a part by using the Systems Director Management Console*.

Determine if you are able to perform this procedure concurrently Attention

Note: Two power supplies must be present in the expansion unit. If one power supply fails, the expansion unit continues to operate. If you are performing this procedure concurrently (with the power turned on), there is a time limit. From the moment the power supply is removed, the exchange of the power supply *must be completed in less than 5 minutes*. If you cannot replace the power supply in less than 5 minutes, the I/O drawer automatically shuts down.

Read the following steps, but do not perform them yet. Then decide if you are ready (and able) to complete this repair within 5 minutes.

1. Have the replacement power supply or fan ready.
2. Remove the power supply from the expansion unit.
3. Install the fan or fans into the power supply as required for the service procedure being performed.
4. Install the power supply into the enclosure.

Note: If you are replacing a midplane or a power supply, ensure that you only replace one of these parts at a time. If a midplane and both power supplies are replaced at the same time, the enclosure vital product data (VPD), which is present only in these entities, is lost. The enclosure VPD is the identity of the 5802 or 5877 enclosure.

If your system is not managed by the HMC or SDMC, complete the following steps to remove a power supply or fan from an expansion unit or system while the system power is turned on:

1. Perform the prerequisite tasks, as described in Before you begin.
2. Open the front rack door.
3. Identify the failing part, as described in Identifying a failing part.
4. At the front of the expansion unit, identify the power supply that must be replaced. To identify the power supply, observe the state of the amber field-replaceable unit (FRU) fault and identify light-emitting diode (LED) **(A)** as shown in Figure 56. A lit (flashing or on solid) LED indicates the failing power supply.

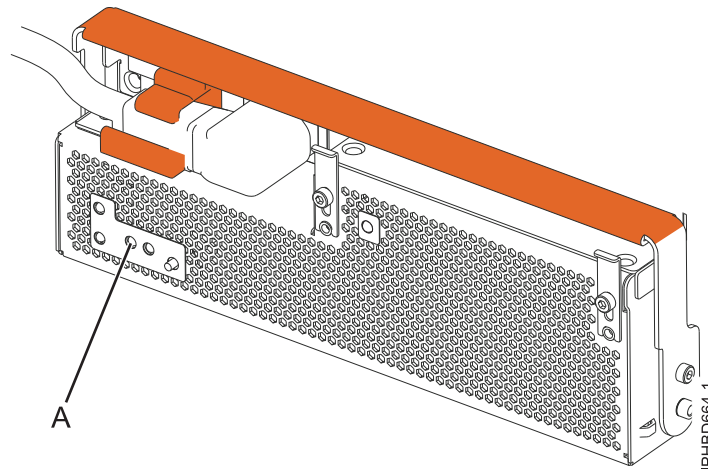

Figure 56. FRU fault and identify LED

5. For the power supply that you want to remove, slide the cable retention bracket to the open position **(A)**, and then disconnect the power cable **(B)** as shown in Figure 57 on page 73. By moving the bracket to the open position, you turn the power supply off.

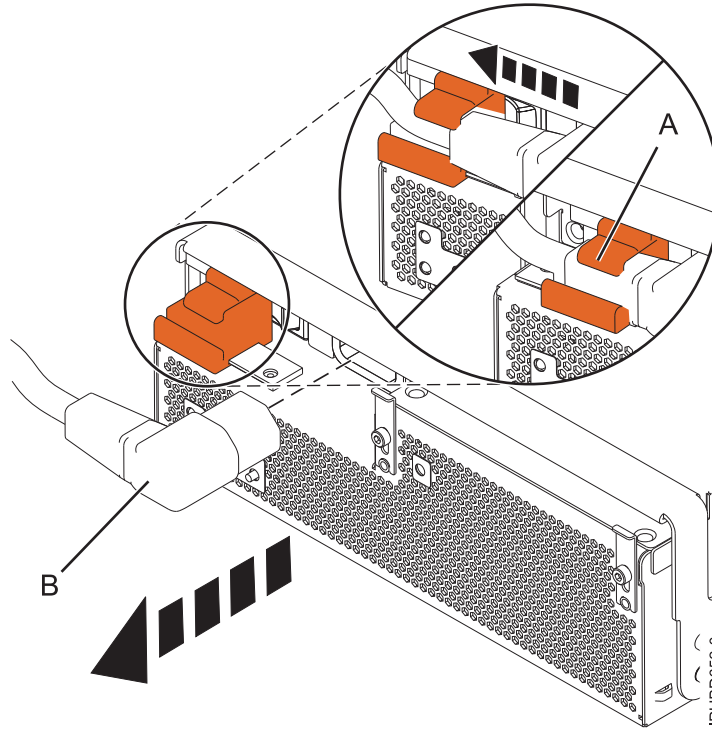

Figure 57. Disconnecting the power cable from the front of an expansion unit

6. Attach the wrist strap.

Attention:

- Attach a wrist strap to an unpainted surface of your hardware to prevent electrostatic discharge (ESD) from damaging your hardware.
 - When using a wrist strap, follow all electrical safety procedures. A wrist strap is for static control. It does not increase or decrease your risk of receiving electric shock when using or working on electrical equipment.
 - If you do not have a wrist strap, just prior to removing the product from ESD packaging and installing or replacing hardware, touch an unpainted surface of the system for a minimum of 5 seconds.
7. Rotate the power-supply locking handle (A) to the open position as shown in Figure 58 on page 74. Pull the power supply out of the expansion unit.

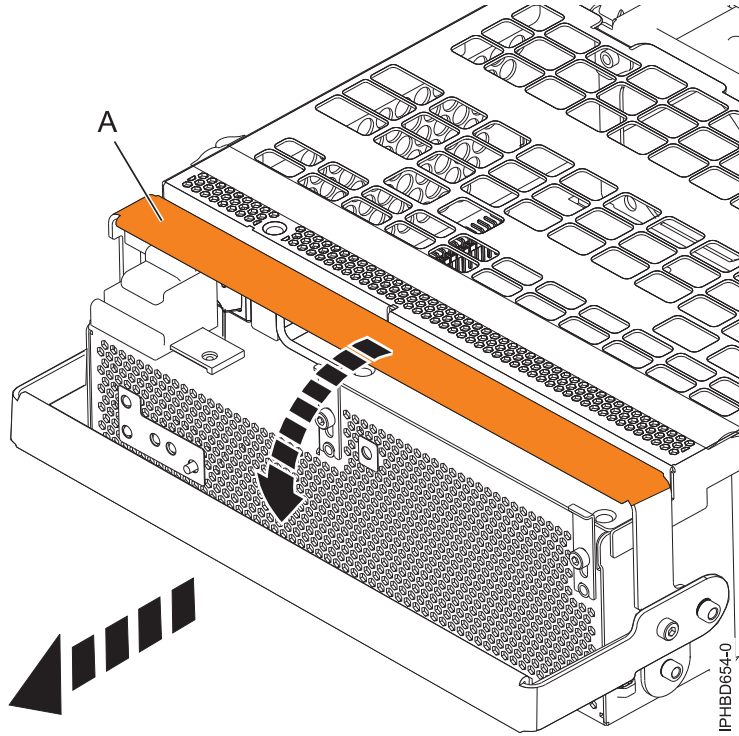

Figure 58. Removing a power supply

8. Optional: If you want to remove a failing power-supply fan, complete the following steps:

Note: If a fan fails, the amber fan fault LED (**B**) on the front of the Offline Converter Assembly (OCA), as shown in Figure 59, is on solid.

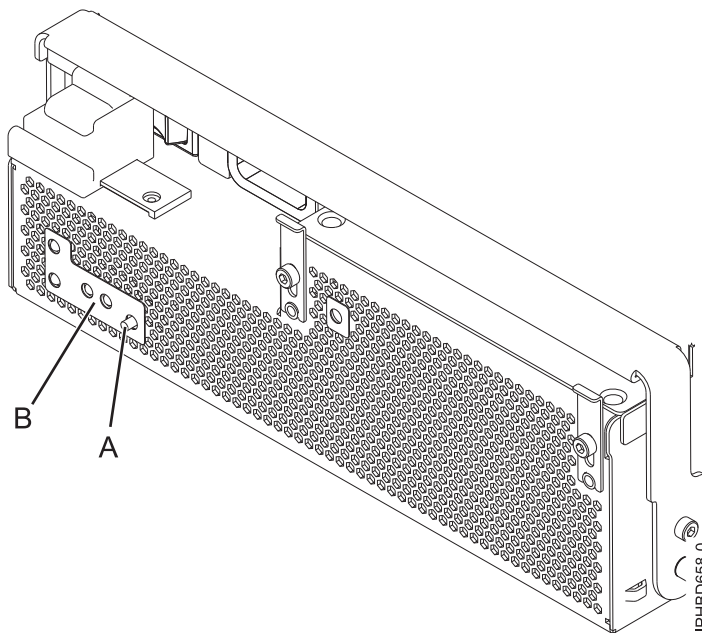

Figure 59. Fan fault LED and fan identify button

- a. To identify the failing fan, press the fan identify button (A), as shown in Figure 59 on page 74. An amber left or right fan-fault LED (C) on solid, as shown in Figure 60, indicates the faulty fan.

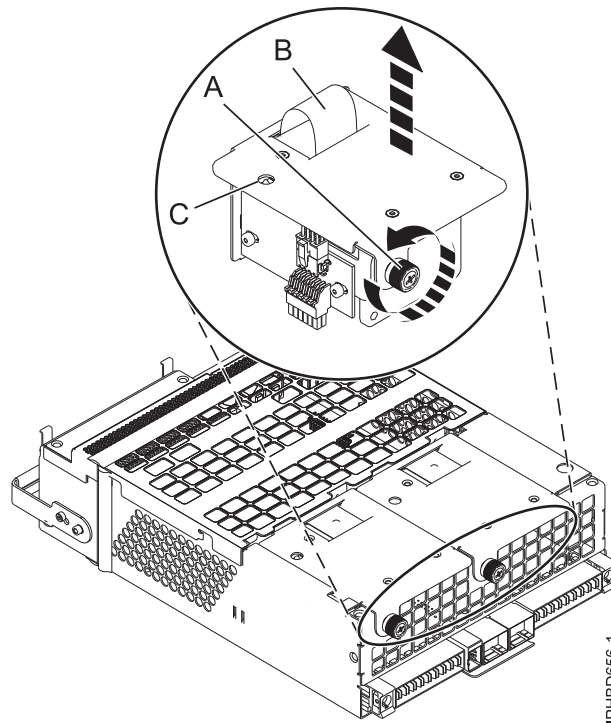

Figure 60. Removing a fan

- b. Loosen the thumbscrew (A) that holds the fan in the power-supply assembly, as shown in Figure 60.
- c. Use the recessed fan handle (B) to lift the fan from the power-supply assembly, as shown in Figure 60.

If you removed the power supply or fan as part of another service action, or if you want to replace the power supply or fan that you removed from an expansion unit, see *Replacing a power supply or fan in a 5802 or 5877 expansion unit with the power turned on*.

Replacing a power supply or fan with power on

If your system is managed by the Hardware Management Console (HMC), use the HMC to replace a power supply. For instructions, see *Exchanging a part by using the Hardware Management Console*.

If your system is managed by the IBM Systems Director Management Console (SDMC), use the SDMC to replace a power supply in the server. For instructions, see *Replacing a part by using the Systems Director Management Console*.

Determine if you are able to perform this procedure concurrently

Attention: Two power supplies must be present in the expansion unit. If one power supply fails, the expansion unit continues to operate. If you are performing this procedure concurrently (with the power turned on), there is a time limit. From the moment the power supply is removed, the exchange of the power supply *must be completed in less than 5 minutes*. If you cannot replace the power supply in less than 5 minutes, the I/O drawer automatically shuts down.

Before installing or reinstalling a power supply, inspect the signal connector pins to ensure that the pins are not bent or damaged.

Attention: Bent pins damage the midplane receptacle. Be careful not to touch or damage the signal connector pins.

Read the following steps, but do not perform them yet. Then decide if you are ready (and able) to complete this repair within 5 minutes.

1. Have the replacement power supply or fan ready.
2. Remove the power supply from the expansion unit.
3. Install the fan or fans into the power supply as required for the service procedure being performed.
4. Install the power supply into the enclosure.

If your system is not managed by the HMC or SDMC, complete the following steps to replace the power supply in an expansion unit or system while the system power is turned on:

1. If you are replacing a power supply or power-supply fan because of a failure, remove the failing part as described in Removing a power supply or fan from a 5802 or 5877 expansion unit with the power turned on.
2. Perform the prerequisite tasks, as described in Before you begin.
3. Open the front rack door.
4. Attach the wrist strap.

Attention:

- Attach a wrist strap to an unpainted surface of your hardware to prevent electrostatic discharge (ESD) from damaging your hardware.
 - When using a wrist strap, follow all electrical safety procedures. A wrist strap is for static control. It does not increase or decrease your risk of receiving electric shock when using or working on electrical equipment.
 - If you do not have a wrist strap, just prior to removing the product from ESD packaging and installing or replacing hardware, touch an unpainted surface of the system for a minimum of 5 seconds.
5. Optional: If you must replace a failing power-supply fan, complete the following steps:
 - a. Align the new fan with the opening in the power-supply assembly.
 - b. Press the fan (**A**) into its connector in the assembly as shown in Figure 61 on page 77.
 - c. Tighten the thumbscrew (**D**) as shown in Figure 61 on page 77.

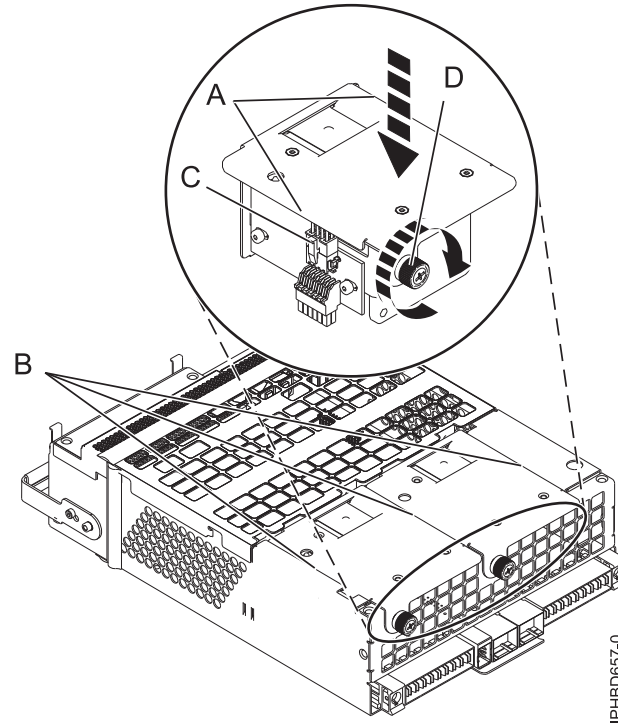

IPHBD657-0

Figure 61. Replacing a fan

6. To replace the power supply, with the locking handle (A) in the open position, push the power supply into the expansion unit as shown in Figure 62.

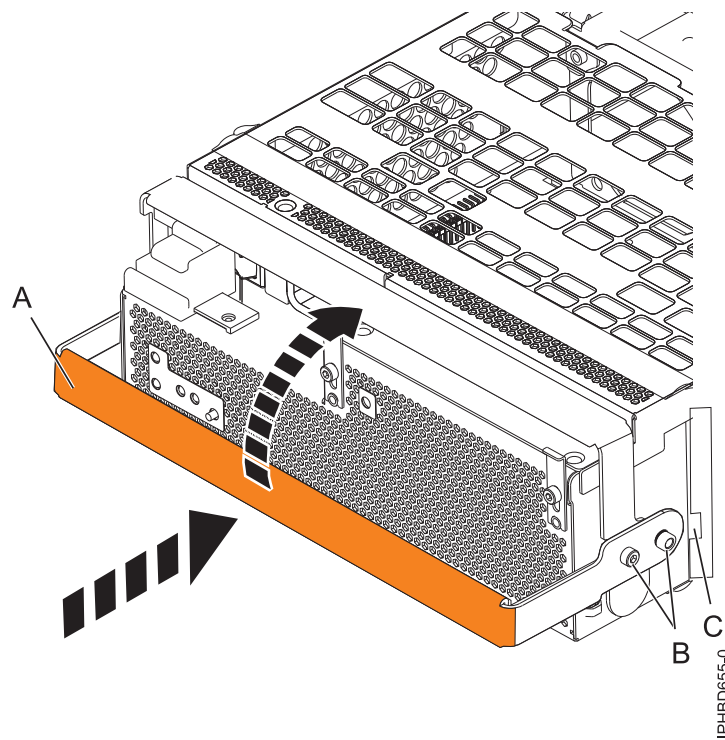

IPHBD655-0

Figure 62. Replacing a power supply

7. Close the locking handle (A) until the power supply locks into position.

8. Reconnect the power cable **(A)** to the front of the power supply, and then slide the cable retention bracket **(B)** to the closed position to secure the cable as shown in Figure 63. By moving the bracket to the closed position, you turn on the power supply.

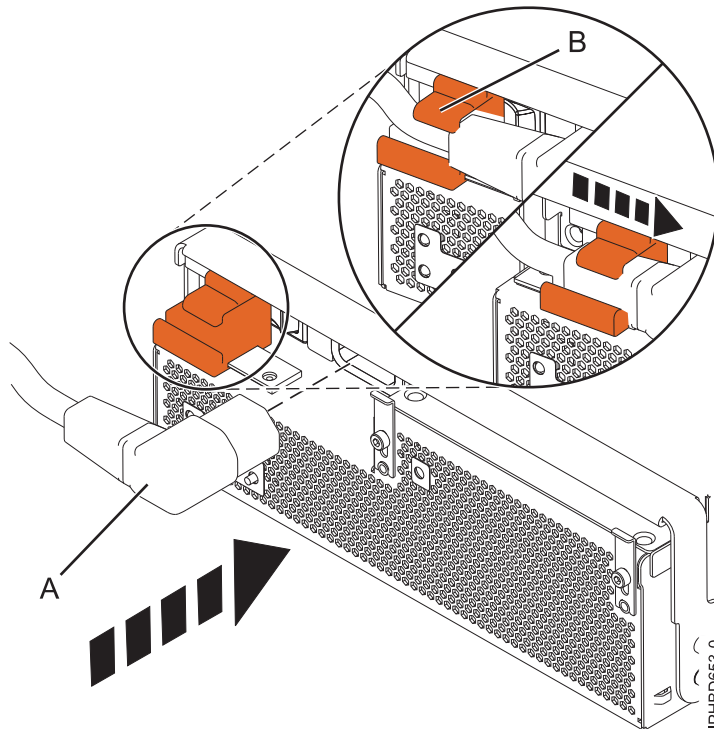

Figure 63. Connecting the power cable to the front of an expansion unit

9. Note the state of the green ac power in **(A)** and Offline Converter Assembly (OCA) power **(B)** light-emitting diodes (LEDs) shown in Figure 64 on page 79, and do one of the following actions, as applicable:
 - If the LEDs indicate that the power supply is operating normally, that is, that the ac power in LED **(A)** is on solid and the OCA power **(B)** LED is on solid or flashing, continue to the next step.
 - If not, remove the power supply from the expansion unit and repeat the procedure starting with step 6 on page 77. If, after repeating the procedure, the power supply is not operating normally, contact your service provider.

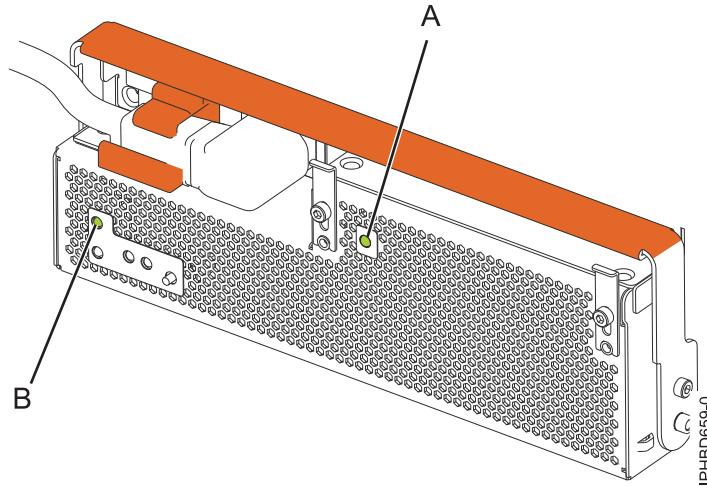

Figure 64. Expansion unit ac power and OCA power LEDs

Note: If you replaced a power-supply fan as part of this procedure, note the state of the fan fault LED (**B**) shown in Figure 65. If the LED is off, indicating that both fans are operating normally, continue to the next step. If not, remove the power-supply assembly from the expansion unit and repeat the procedure starting with step 5 on page 76. If, after repeating the procedure, the power-supply fan is not operating normally, contact your service provider.

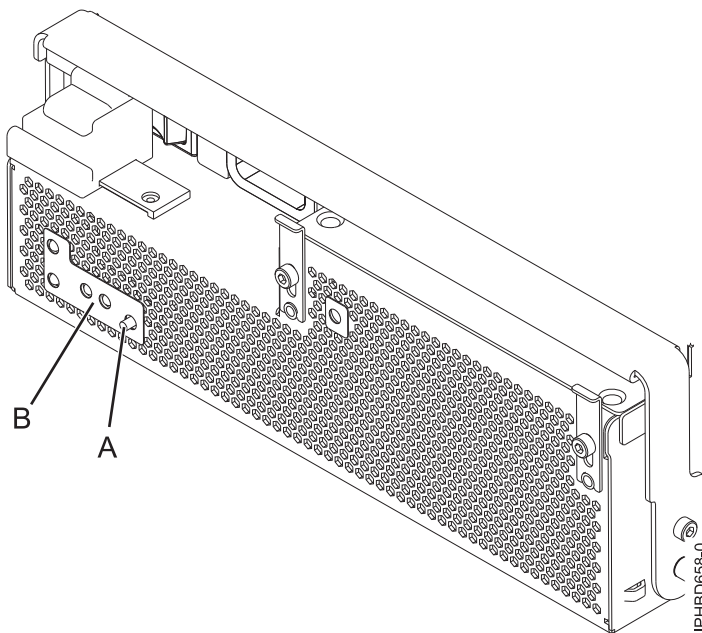

Figure 65. Fan fault LED

10. Verify the installed part, as described in Verifying the installed part.
11. Close the front rack door.

Continue with any other service actions you want to perform.

SAS conduit card (FRU)

Use these procedures to install and remove the SAS conduit card.

Removing a SAS conduit card from a 5802 expansion unit with power off

Learn how to remove a SAS conduit card from a 5802 (rack-mounted) expansion unit if you need to replace a failing part with power off.

If your system is managed by the Hardware Management Console (HMC) use the HMC to remove the SAS conduit card. For instructions see, Removing a part by using the Hardware Management Console.

1. Perform the prerequisite tasks as described in “Before you begin” on page 63.
2. Identify the card you are going to remove. For instructions see, “Identifying a part” on page 101.
3. Before removing a SAS conduit card, inspect the signal connector pins to ensure that the pins are not bent or damaged.

Attention: Bent pins damage the backplane receptacle. Be careful not to touch or damage the signal connector pins.

4. Stop the system. For instructions see, “Stopping a system or logical partition” on page 107.
5. Disconnect the power source from the system by unplugging the system.

Attention: You must disconnect the power source from the system by disconnecting all power cords to prevent system damage during this procedure.

(L003)

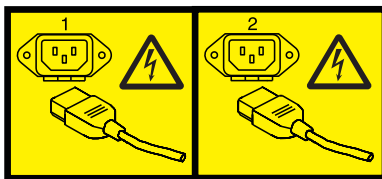

or



6. Remove the disk drives and fillers as shown in the following figure. Record the location of each of the disk drives you remove. The disk drives must be reinstalled to the same location again.
 - a. Squeeze the latch of the disk drive and pull the handle (A) toward you to release the drives.
 - b. Supporting the bottom of the disk drive with your hand, slide it out of the backplane.

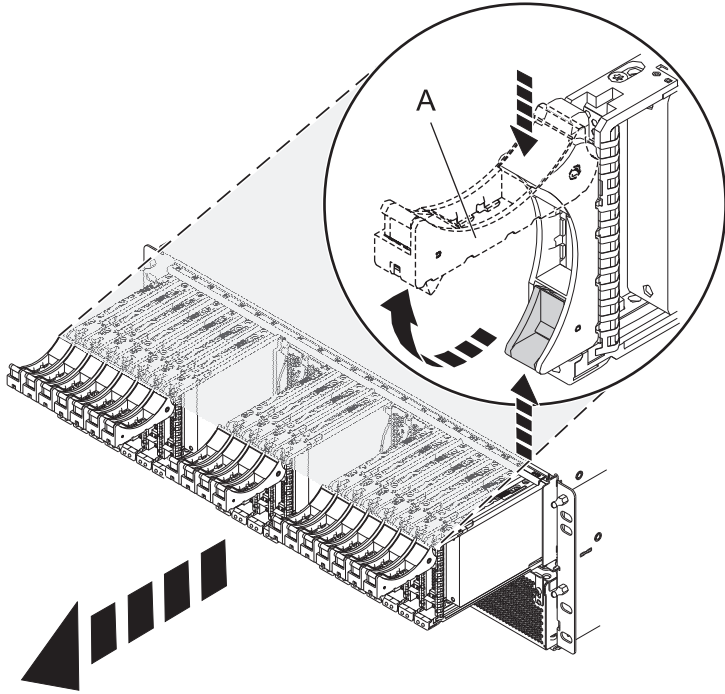

Figure 66. Removing the disk drives from the backplane

7. Remove the port cards and fillers as shown in the following figure.
 - a. Grasp the end of the latching handle (**A**) and pull it upward to unlock the port card.
 - b. Using your hand to support the bottom of the port card, slide it out of the backplane.
 - c. Place the port card on an electrostatic discharge (ESD) surface.

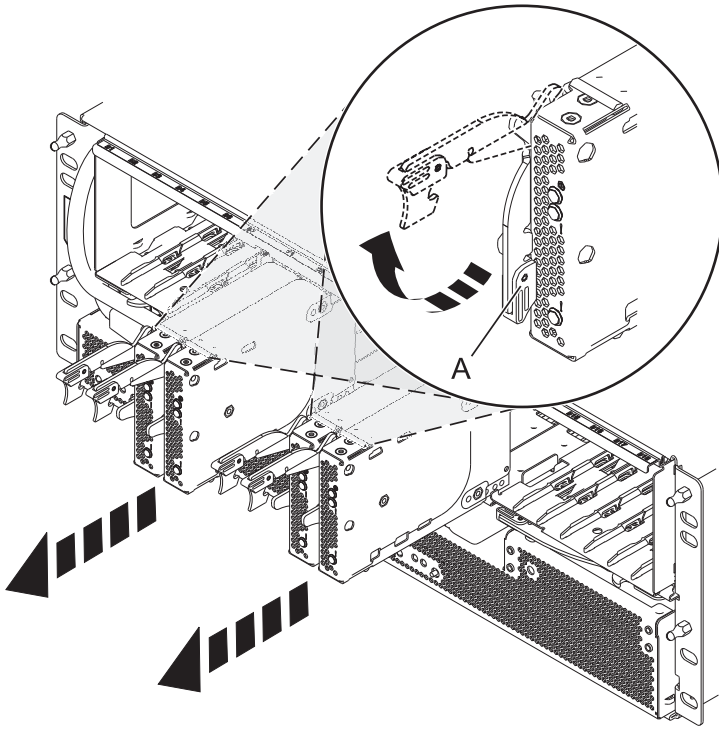

Figure 67. Removing the port card from the backplane

8. Disconnect both offline converter assembly (OCA) power cords by doing the following:
 - a. On the front of both OCAs, slide the power cord holders **(A)** to the left.
 - b. Label and disconnect both OCA power cords **(B)** from each OCA.

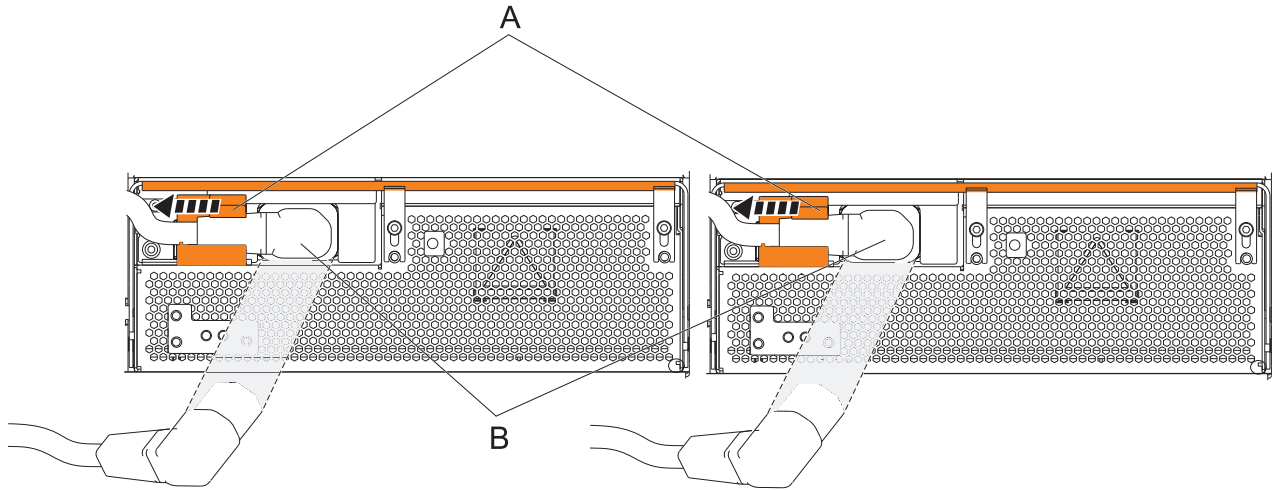

Figure 68. Disconnecting the OCA power cords

9. Remove the backplane as shown in the following figure.

CAUTION:

The backplane might be heavy. Ensure that you can safely complete the procedure.

- a. Squeeze the blue latches (**A**) to unlock the handles.
- b. Pull the handles (**B**) outward in the direction shown to release the backplane.
- c. Slide the backplane out of the enclosure, using your hand to support the bottom of the backplane.

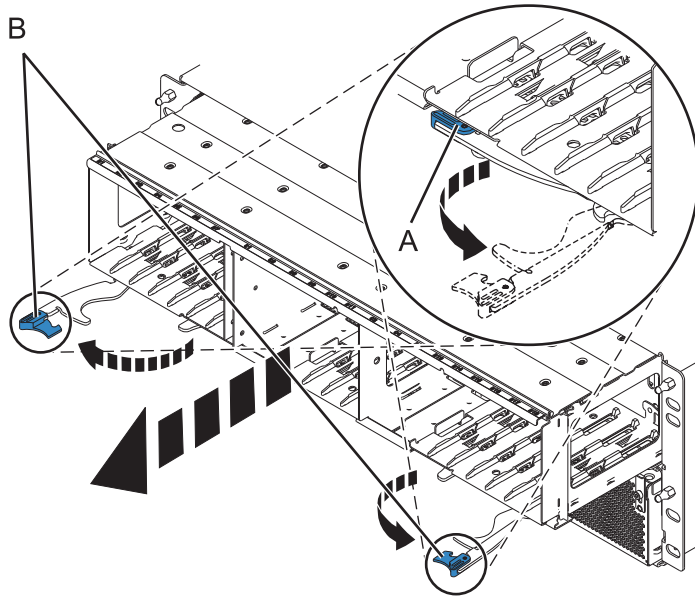

Figure 69. Removing the backplane from the enclosure

10. Disconnect both offline converter assembly (OCA) power cords by doing the following:
 - a. On the front of both OCAs, slide the power cord holders **(A)** to the left.
 - b. Label and disconnect both OCA power cords **(B)** from each OCA.

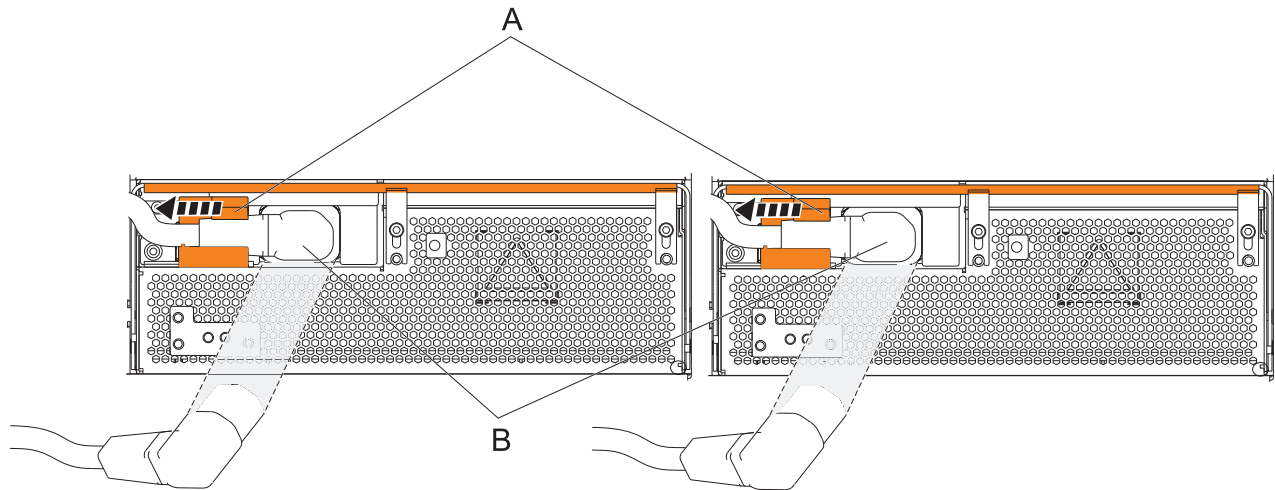

Figure 70. Disconnecting the OCA power cords

11. Remove the offline converter assemblies by doing the following steps:
 - a. Pull the OCA handle (A) all the way down in the direction shown to unseat the OCA.
 - b. Grasp both sides of the OCA and pull it out of the enclosure.

Note: Use 2 hands to support the OCA as it is pulled out of the enclosure.

- c. Repeat these steps to remove both OCAs.

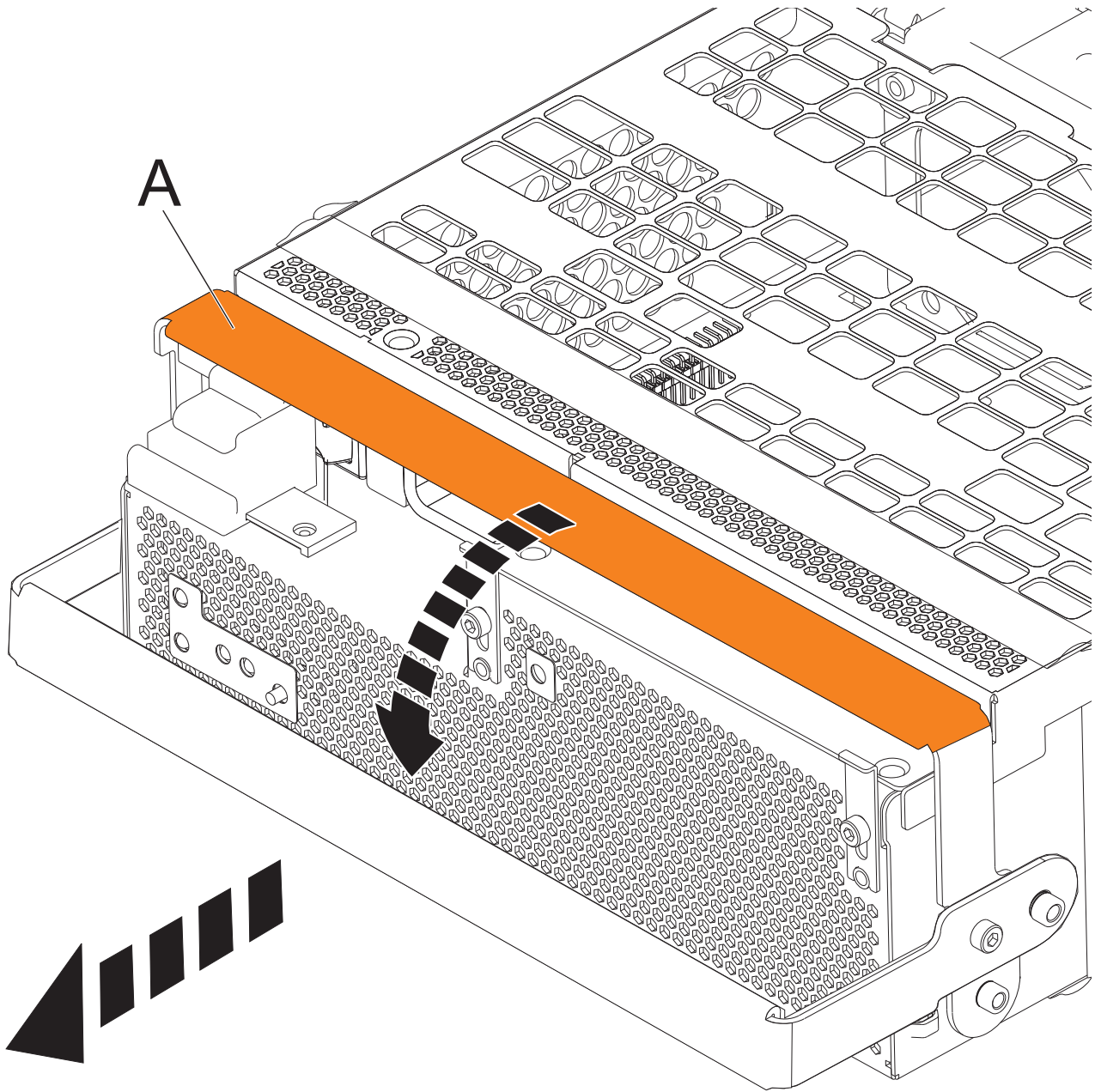
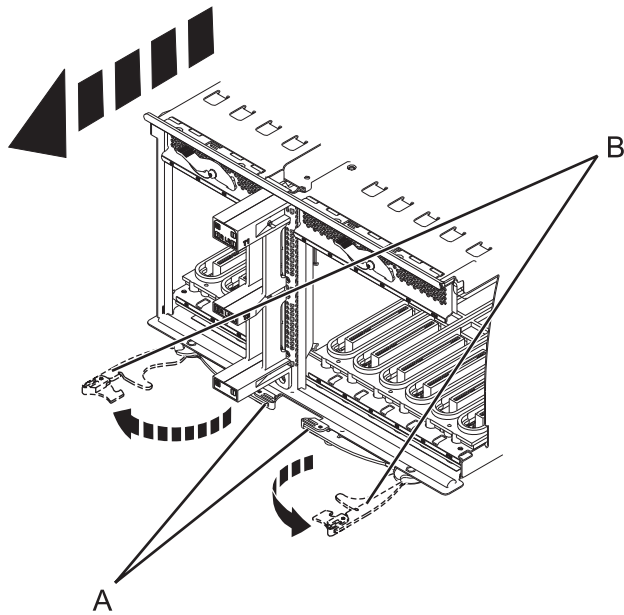

Figure 71. Remove the offline converter assemblies

12. Remove the IO planar
 - a. Label and disconnect any cable connected to the back of the IO planar.
 - b. Pinch the latches (**A**) to unlock the handles.
 - c. Pull the handles (**B**) outward in the direction shown to unseat the IO planar.
 - d. Supporting the bottom of the IO planar, slide the IO planar out of the enclosure.



13. Remove the enclosure management controller card by doing the following steps:
 - a. Label and disconnect any cables connected to the enclosure management controller card.
 - b. Pinch the latch (**A**) to unlock the handle (**B**).
 - c. Pull the handle outward in the direction shown to unseat the EMC card.
 - d. Slide the enclosure management controller card straight out of the enclosure.

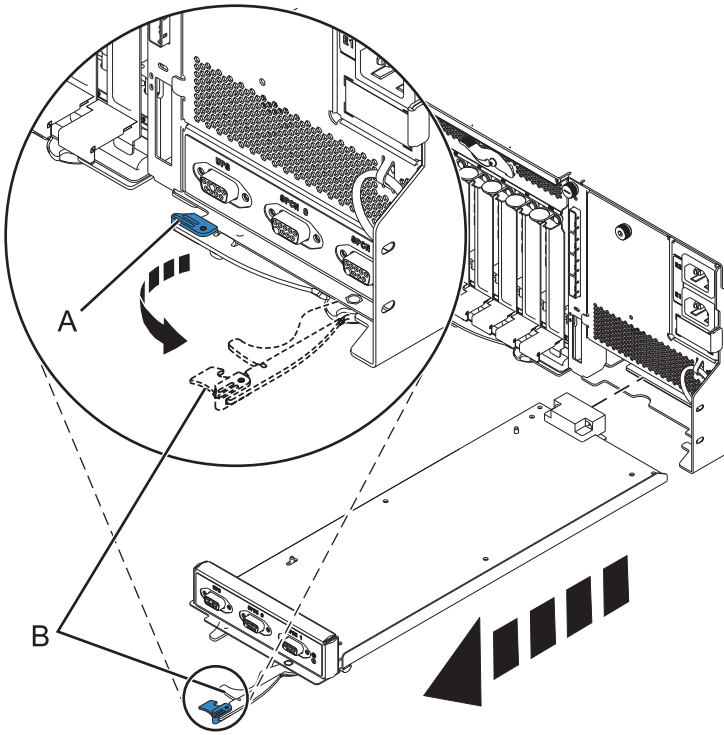

Figure 72. Remove the enclosure management controller

14. Remove the power cord plate by turning the thumbscrew (A) and pulling the plate away from the system.

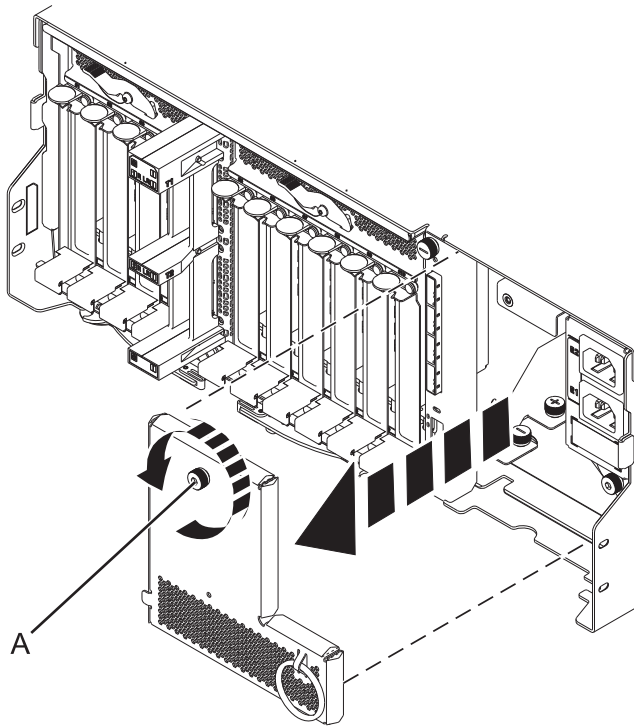

Figure 73. Removing the power cord plate

15. Remove the SAS conduit card and midplane from the enclosure by doing the following steps:

- a. Pull the spring plungers (A) up and turn them one quarter to the left.
- b. Turn the captive screws (B) and (C) counterclockwise until they are completely loosened.
- c. Pull the SAS conduit and midplane component out of the enclosure.

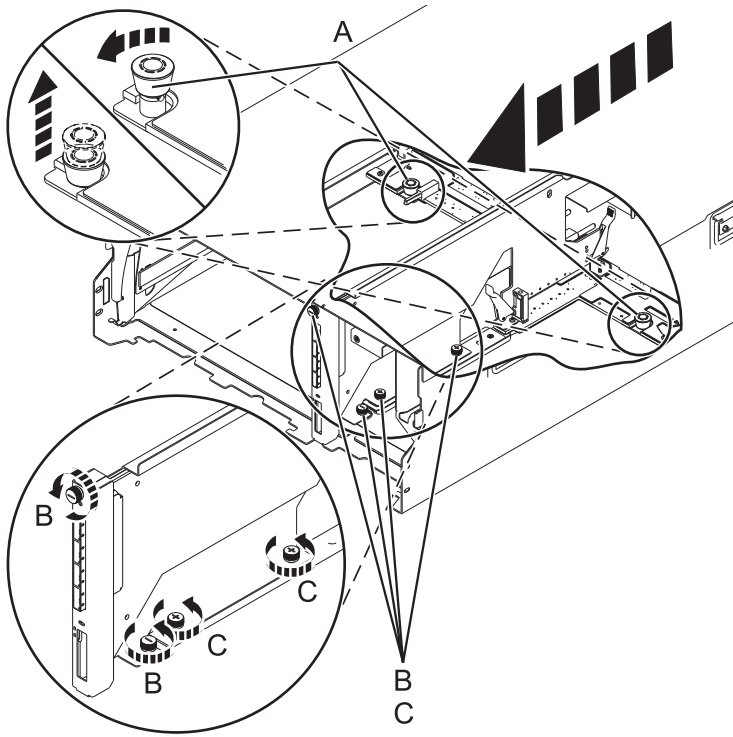

Figure 74. Removing the SAS conduit card and midplane

16. Push the handles (A) on the conduit card down to disengage the card from the midplane, and remove the card.

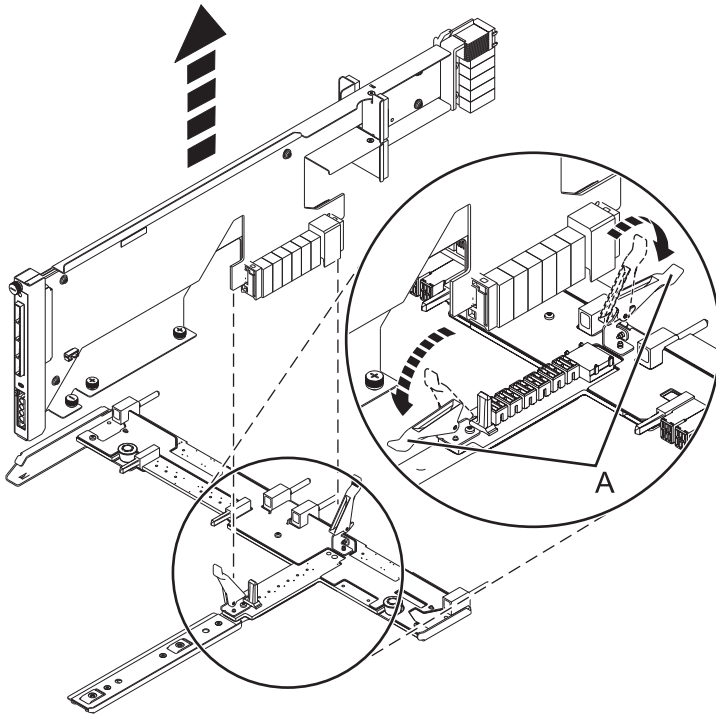

Figure 75. Removing the SAS conduit card from the midplane

Continue with replacing the SAS expander card or return to the procedure that sent you here.

Replacing a SAS conduit card in a 5802 expansion unit with power off

Learn how to replace a SAS conduit card in a 5802 expansion unit with power off.

Review the requirements in “Before you begin” on page 63.

If your system is managed by the Hardware Management Console (HMC), use the HMC to replace the card. For instructions see, Removing a part by using the Hardware Management Console.

1. Stop the system if it is running. For instructions see, “Stopping a system or logical partition” on page 107.
2. Disconnect the power source from the system by unplugging the system.

Attention: You must disconnect the power source from the system by disconnecting all power cords to prevent system damage during this procedure.

(L003)

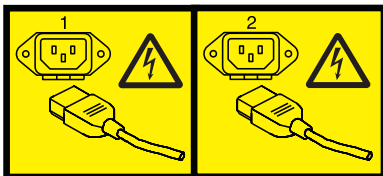

or



3. Place the card connector (C) onto the on the midplane connection (D) using the guide track (B) to ensure a good connection. Then lift the handle (A) to seat and secure the SAS conduit card to the midplane as shown in the following figure.

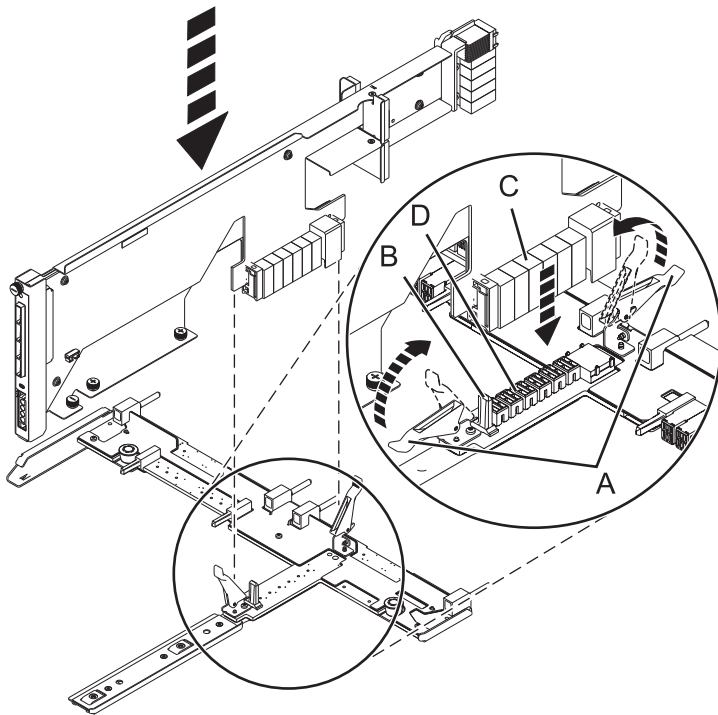

Figure 76. Installing the SAS conduit card into the midplane

4. Place the midplane and SAS conduit card back into the system by doing the following steps:
 - a. Align the midplane with the track and ensure the slot (A) on the midplane attaches to the post (B) in the system.
 - b. Secure the thumbscrews (C) and (D) on the SAS conduit card.
 - c. Secure the thumbscrews (E) on the sides of the midplane.

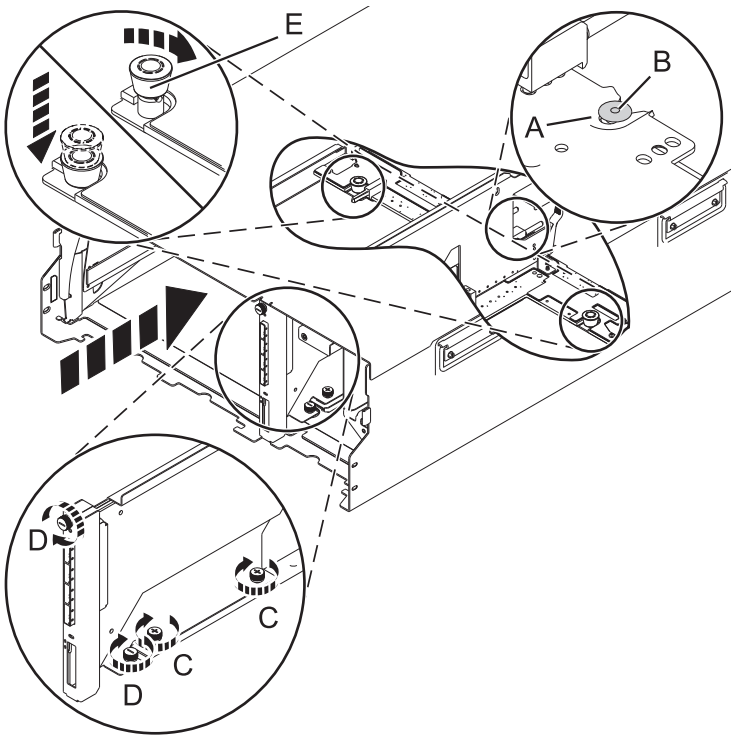

Figure 77. Installing the SAS conduit card and the midplane

5. Attach the power cord cover and secure the thumbscrew (A) to the system.

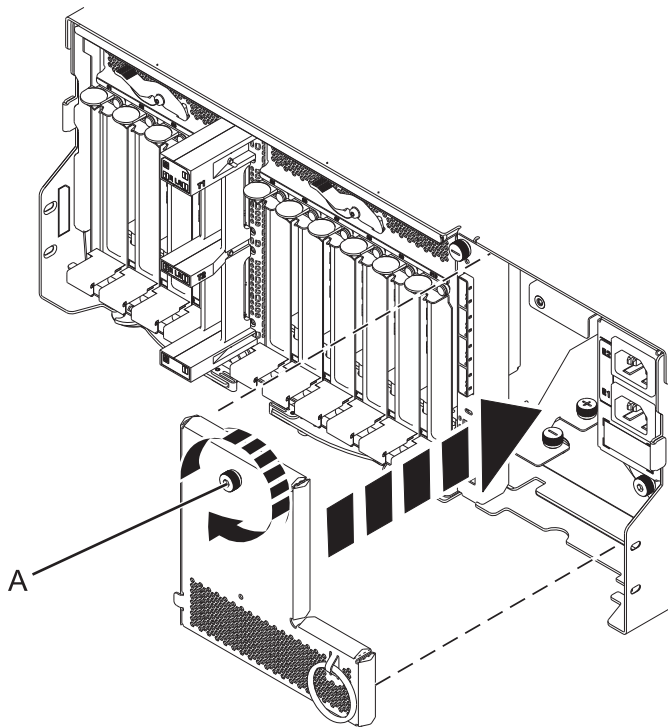

Figure 78. Installing the power cord plate

- Carefully slide the enclosure management controller into the system and close the latch (A) as shown in the following figure.

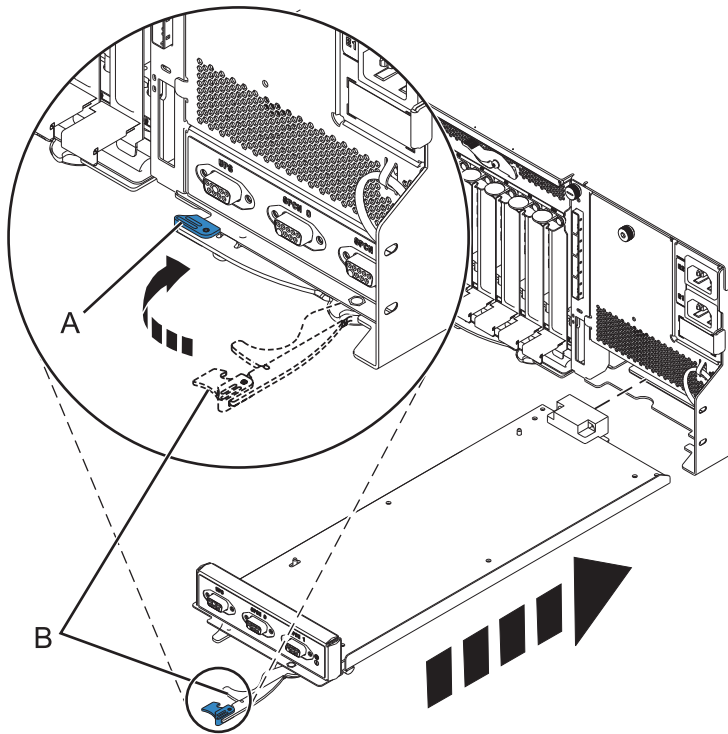

Figure 79. Replacing the enclosure management controller

- Reconnect power to the 5802 expansion unit by re-plugging both power cords to the rear of the enclosure.
- Carefully lift and align the I/O planar with the slot at the back of the expansion unit.
- Insert the I/O planar firmly into the server, as shown in the following figure.
- Secure the I/O planar with the locking tabs (A) as shown in the following figure.

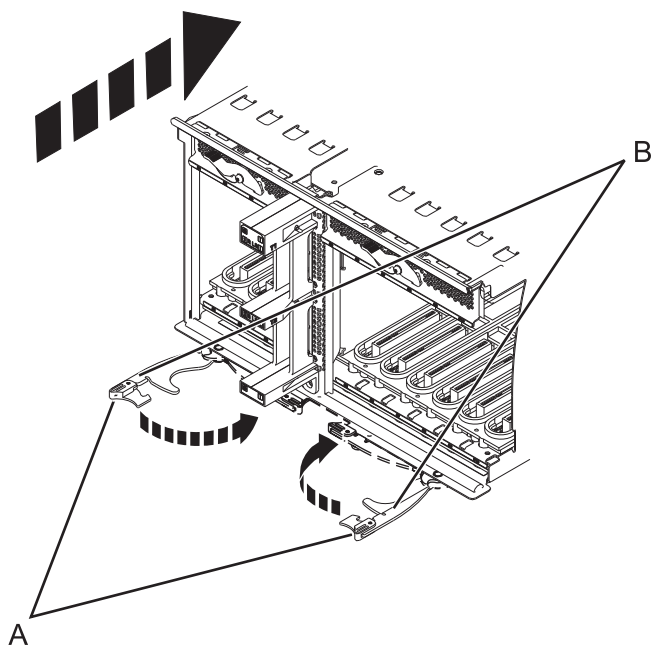

Figure 80. Install the I/O planar on a rack mounted model

11. To replace the power supply, with the locking handle (A) in the open position, push the power supply into the expansion unit as shown in the following figure.
12. Close the locking handle (A) until the power supply locks into position.

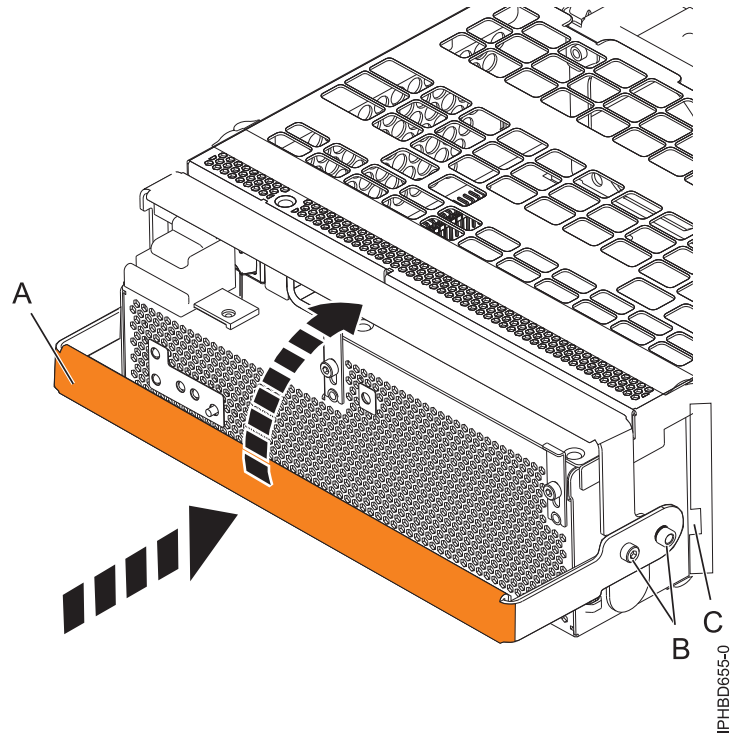

Figure 81. Replacing a power supply

13. Reconnect the power cable (A) to the front of the power supply, and then slide the cable retention bracket (B) to the closed position to secure the cable. By moving the bracket to the closed position, you turn the power supply on.

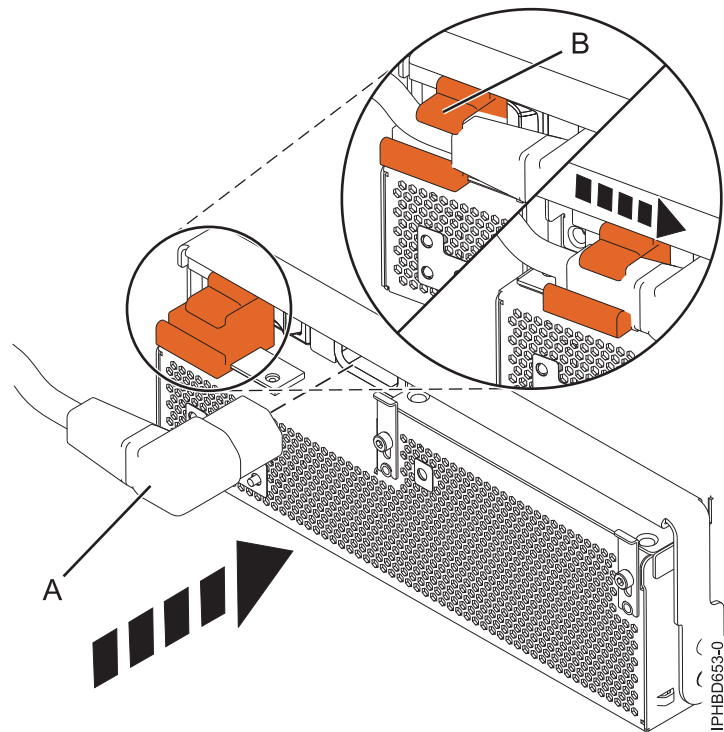

Figure 82. Connecting the power cable to the front of an expansion unit

14. Note the state of the green ac power in (A) and Offline Converter Assembly (OCA) power (B) light-emitting diodes (LEDs), and do one of the following actions, as applicable:
 - If the LEDs indicate that the power supply is operating normally, that is, that the ac power in LED (A) is on solid and the OCA power (B) LED is on solid or blinking, continue to the next step.
 - If not, remove the power supply from the expansion unit and repeat the procedure starting with step 11 on page 94. If, after repeating the procedure, the power supply is not operating normally, contact your service provider.
 15. To replace the disk drive backplane, lift the backplane along the two sides and align with the guide rails in the expansion unit.
- CAUTION:**
The backplane may be heavy. Ensure that you can safely perform this task before you begin.
16. Using your hand to support the bottom of the backplane, slide it into the expansion unit as shown in the following figure.
 17. Secure the backplane in place by moving the locking tabs from the open position (B) to the locked position (A).

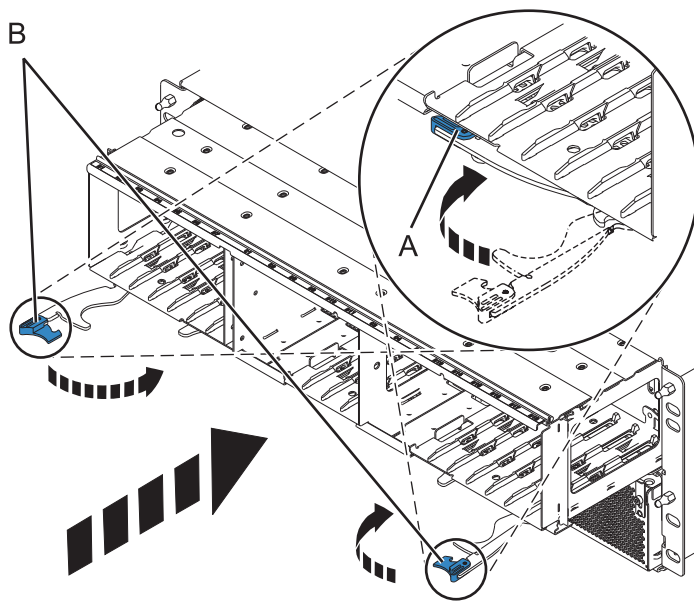

Figure 83. Installing the backplane on a rack-mounted model

18. Start the system. For instructions see, “Starting the system or logical partition” on page 105.

Continue with any other service actions you need to perform.

- For information on connecting the system see Connecting your expansion units
- For information on installing the PCI adapters into the planar, see Model 5802 and 5877 expansion units, PCI adapters, and cassettes.

SAS expander card (CRU)

Use this procedure to install and remove the serial attached SCSI (SAS) expander card

Removing a SAS expander card with power off

If your system is managed by the Hardware Management Console (HMC) use the HMC to remove the SAS expander card. For instructions see, “Removing a part by using the Hardware Management Console” on page 109.

1. Perform the prerequisite tasks as described in “Before you begin” on page 63.
2. Identify the card you are going to remove. For instructions see, “Identifying a part” on page 101.
3. Lift the handle (A) and pull the card out of the system, as shown in the following figure.

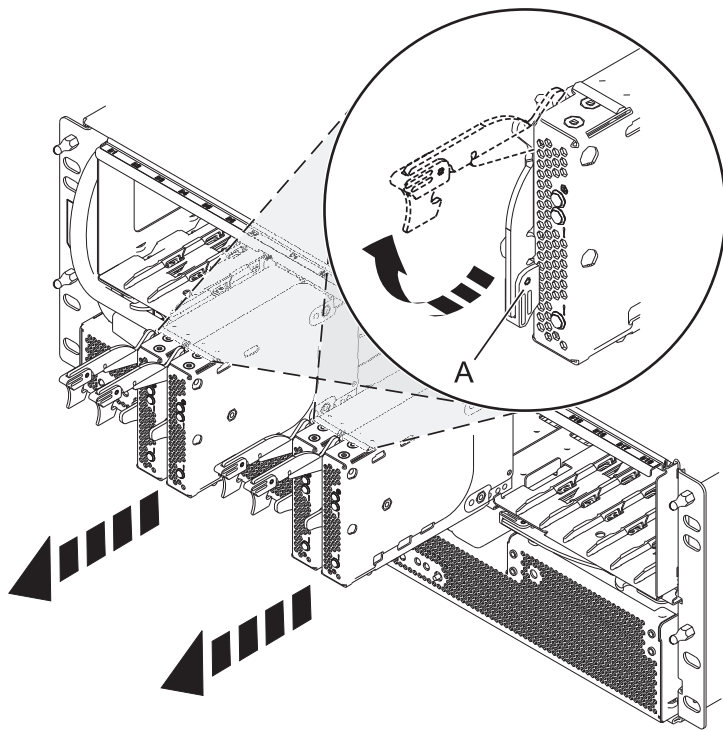

Figure 84. Removing the SAS expander card.

Continue with replacing the SAS expander card or return to the procedure that sent you here.

Replacing a SAS expander card with power off

Review the requirements in “Before you begin” on page 63.

If your system is managed by the Hardware Management Console (HMC) use the HMC to replace the card. For instructions see, “Removing a part by using the Hardware Management Console” on page 109

1. Before installing or reinstalling a SAS expander card, inspect the signal connector pins to ensure that the pins are not bent or damaged.
Attention: Bent pins damage the backplane receptacle. Be careful not to touch or damage the signal connector pins.
2. Slide the card completely into the slot and push the lever (A) down to secure the card as shown in the following figure.

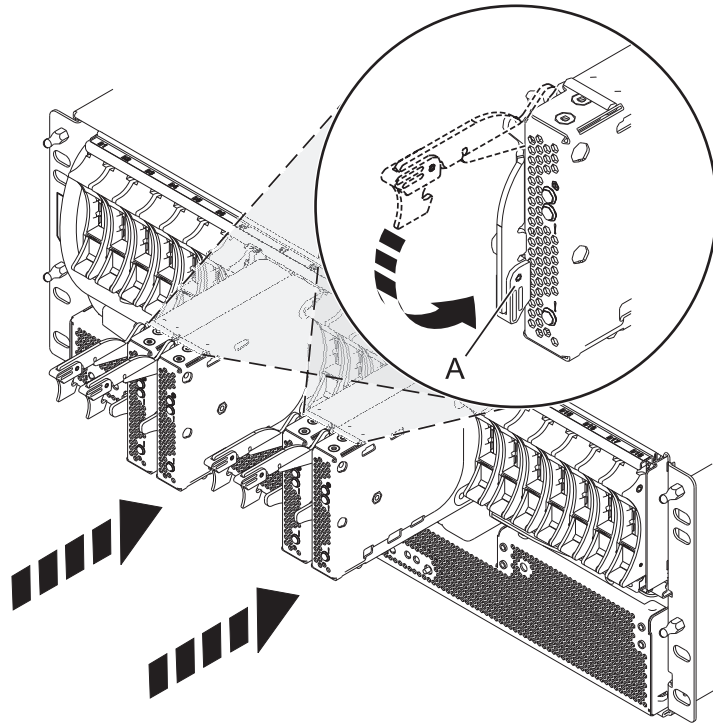

Figure 85. Installing the SAS expander card

3. Start the system. For instructions see, “Starting the system or logical partition” on page 105.
4. Verify the presence of the newly installed card. For instructions see, “Verifying the installed part” on page 111.

Continue with any other service actions you need to perform.

Common procedures

This section contains common procedures related to installing, removing, and replacing parts.

Before you begin

Observe these precautions when you are installing, removing, or replacing features and parts.

These precautions are intended to create a safe environment to service your system and do not provide steps for servicing your system. The installation, removal and replacement procedures provide the step-by-step processes required to service your system.

DANGER

When working on or around the system, observe the following precautions:

Electrical voltage and current from power, telephone, and communication cables are hazardous. To avoid a shock hazard:

- Connect power to this unit only with the IBM provided power cord. Do not use the IBM provided power cord for any other product.
- Do not open or service any power supply assembly.
- Do not connect or disconnect any cables or perform installation, maintenance, or reconfiguration of this product during an electrical storm.
- The product might be equipped with multiple power cords. To remove all hazardous voltages, disconnect all power cords.
- Connect all power cords to a properly wired and grounded electrical outlet. Ensure that the outlet supplies proper voltage and phase rotation according to the system rating plate.
- Connect any equipment that will be attached to this product to properly wired outlets.
- When possible, use one hand only to connect or disconnect signal cables.
- Never turn on any equipment when there is evidence of fire, water, or structural damage.
- Disconnect the attached power cords, telecommunications systems, networks, and modems before you open the device covers, unless instructed otherwise in the installation and configuration procedures.
- Connect and disconnect cables as described in the following procedures when installing, moving, or opening covers on this product or attached devices.

To Disconnect:

1. Turn off everything (unless instructed otherwise).
2. Remove the power cords from the outlets.
3. Remove the signal cables from the connectors.
4. Remove all cables from the devices

To Connect:

1. Turn off everything (unless instructed otherwise).
2. Attach all cables to the devices.
3. Attach the signal cables to the connectors.
4. Attach the power cords to the outlets.
5. Turn on the devices.

(D005)

DANGER

Observe the following precautions when working on or around your IT rack system:

- Heavy equipment—personal injury or equipment damage might result if mishandled.
- Always lower the leveling pads on the rack cabinet.
- Always install stabilizer brackets on the rack cabinet.
- To avoid hazardous conditions due to uneven mechanical loading, always install the heaviest devices in the bottom of the rack cabinet. Always install servers and optional devices starting from the bottom of the rack cabinet.
- Rack-mounted devices are not to be used as shelves or work spaces. Do not place objects on top of rack-mounted devices.



- Each rack cabinet might have more than one power cord. Be sure to disconnect all power cords in the rack cabinet when directed to disconnect power during servicing.
- Connect all devices installed in a rack cabinet to power devices installed in the same rack cabinet. Do not plug a power cord from a device installed in one rack cabinet into a power device installed in a different rack cabinet.
- An electrical outlet that is not correctly wired could place hazardous voltage on the metal parts of the system or the devices that attach to the system. It is the responsibility of the customer to ensure that the outlet is correctly wired and grounded to prevent an electrical shock.

CAUTION

- Do not install a unit in a rack where the internal rack ambient temperatures will exceed the manufacturer's recommended ambient temperature for all your rack-mounted devices.
- Do not install a unit in a rack where the air flow is compromised. Ensure that air flow is not blocked or reduced on any side, front, or back of a unit used for air flow through the unit.
- Consideration should be given to the connection of the equipment to the supply circuit so that overloading of the circuits does not compromise the supply wiring or overcurrent protection. To provide the correct power connection to a rack, refer to the rating labels located on the equipment in the rack to determine the total power requirement of the supply circuit.
- *(For sliding drawers.)* Do not pull out or install any drawer or feature if the rack stabilizer brackets are not attached to the rack. Do not pull out more than one drawer at a time. The rack might become unstable if you pull out more than one drawer at a time.
- *(For fixed drawers.)* This drawer is a fixed drawer and must not be moved for servicing unless specified by the manufacturer. Attempting to move the drawer partially or completely out of the rack might cause the rack to become unstable or cause the drawer to fall out of the rack.

(R001)

Before you begin a replacement or installation procedure, perform these tasks:

1. If you are installing a new feature, ensure that you have the software required to support the new feature.
To do this, go to the following Web site: IBM Prerequisite
2. If you are performing an installation or replacement procedure that might put your data at risk, ensure, wherever possible, that you have a current backup of your system or logical partition (including operating systems, licensed programs, and data).
3. Review the installation or replacement procedure for the feature or part.
4. Note the significance of color on your system.

Blue or terra-cotta on a part of the hardware indicates a touch point where you can grip the hardware to remove it from or install it in the system, open or close a latch, and so on. Terra-cotta might also indicate that the part can be removed and replaced with the system or logical partition power on.

5. Ensure that you have access to a medium flat-blade screwdriver, a Phillips screwdriver, and a pair of scissors.
6. If parts are incorrect, missing, or visibly damaged, do the following:
 - If you are replacing a part, contact the provider of your parts or next level of support.
 - If you are installing a feature, contact one of the following service organizations:
 - The provider of your parts or next level of support.
 - In the United States, the IBM Rochester Manufacturing Automated Information Line (R-MAIL) at 1-800-300-8751.

In countries and regions outside of the United States, use the following Web site to locate your service and support telephone numbers:

<http://www.ibm.com/planetwide>

7. If you encounter difficulties during the installation, contact your service provider, your IBM reseller, or your next level of support.
8. If you are installing new hardware in a logical partition, you need to understand and plan for the implications of partitioning your system. For information, see Logical Partitioning.

Identifying a part

Use these instructions to learn how to identify the location of a failed part, the location of a part to be removed, or the location to install a new part on your system or expansion unit using the appropriate method for your system.

For IBM Power Systems servers that contain the POWER7 processor, the light-emitting diodes (LEDs) can be used to identify or verify the location of a part that you are removing, servicing, or installing.

The fault (amber) LED indicates an error and corresponds to the location code in the system reference code (SRC). The LED is activated and deactivated automatically.

If you need to use the identify function, use the following procedures.

Identifying a failing part in an AIX system or logical partition

Use these instructions to learn how to locate a failing part, and then activate the indicator light for that part on a system or logical partition running the AIX operating system.

Locating a failing part in an AIX system or logical partition:

You might need to use AIX tools, before activating the indicator light, to locate a part that is failing.

1. Log in as root user or `celogin-`.
2. At the command line, type `diag` and press Enter.
3. From the Function Selection menu, select **Task Selection** and press Enter.
4. Select **Display Previous Diagnostic Results** and press Enter.
5. From the Display Previous Diagnostic Results display, select **Display Diagnostic Log Summary**. The Display Diagnostic Log display shows a chronological list of events.
6. Look in the **T** column for the most recent **S** entry. Select this row in the table and press Enter.
7. Select **Commit**. The details of this log entry are shown.
8. Record the location information and the SRN value shown near the end of the entry.
9. Exit to the command line.

Use the location information for the failing part to activate the indicator light that identifies the failing part. "Activating the indicator light for the failing part."

Activating the indicator light for the failing part:

Use these instructions to help physically identify the location of a part you are servicing.

1. Log in as root user.
2. At the command line, type `diag` and press Enter.
3. From the Function Selection menu, select **Task Selection** and press Enter.
4. From the Task Selection menu, select **Identify and Attention Indicators** and press Enter.
5. From the list of lights, select the location code for the failing part and press Enter.
6. Select **Commit**. This turns on the system attention and indicator light for the failing part.
7. Exit to the command line.

Deactivating the failing-part indicator light:

Use this procedure to turn off any indicator light that you turned on as a part of a service action.

To deactivate the indicator light, follow these steps:

1. Log in as root user.
2. At the command line, type `diag` and press Enter.
3. From the Function Selection menu, select **Task Selection** and press Enter.
4. From the Task Selection menu, select **Identify and Attention Indicators** and press Enter.
5. From the list of lights, select the location code for the failing part and press Enter. When a light is activated for a failing part, an I character precedes the location code.
6. Select **Commit**. This turns off the system attention and indicator light for the failing part.
7. Exit to the command line.

Identifying a failing part in an IBM i system or logical partition

You can activate or deactivate the indicator light by using IBM i to assist in locating a failing part.

Activating the failing-part indicator light:

You can search the service action log for an entry that matches the time, reference code, or resource of a problem, and then activate the indicator light for a failing part.

1. Sign on to an IBM i session, **with at least service level authority**.
2. On the command line of the session, type `strsst` and press Enter.

Note: If you cannot get to the System Service Tools display, use function 21 from the control panel. Alternatively, if the system is managed by a Hardware Management Console (HMC), use the Service Focal Point™ utilities to get to the Dedicated Service Tools (DST) display.

3. Type your service tools user ID and service tools password on the System Service Tools (SST) Sign On display. Press Enter.

Remember: The service tools password is case-sensitive.

4. Select **Start a service tool** from the System Service Tools (SST) display and press Enter.
5. Select **Hardware service manager** from the Start a Service Tool display and press Enter.
6. Select **Work with service action log** from the Hardware Service Manager display and press Enter.
7. On the Select Timeframe display, change the **From: Date and Time** field to a date and time prior to when the problem occurred.
8. Search for an entry that matches one or more conditions of the problem:

- System Reference code
 - Resource
 - Date and time
 - Failing item list
9. Select option 2 (Display failing item information) to display the service action log entry.
 10. Select option 2 (Display details) to display location information for the failing part to be replaced. The information displayed in the date and time fields is the date and time for the first occurrence of the specific System reference code for the resource displayed during the time range selected.
 11. If location information is available, select option 6 (Indicator on) to turn on the failing part's indicator light.

Tip: If the failing part does not contain a physical indicator light, a higher-level indicator light is activated. For example, the indicator light for the backplane or unit that contains the failing part might be lit. In this case, use the location information to locate the actual failing part.

12. Look for the enclosure indicator light to locate the enclosure that contains the failing part.

Deactivating the failing-part indicator light:

Use this procedure to turn off any indicator light that you turned on as a part of a service action.

To deactivate the indicator light, follow these steps:

1. Sign on to an IBM i session, **with at least service level authority**.
2. On the command line of the session, type `strsst` and press Enter.

Note: If you cannot get to the System Service Tools display, use function 21 from the control panel. Alternatively, if the system is managed by a Hardware Management Console (HMC), use the Service Focal Point utilities to get to the Dedicated Service Tools (DST) display.

3. Type your service tools user ID and service tools password on the System Service Tools (SST) Sign On display. Press Enter.

Remember: The service tools password is case-sensitive.

4. Select **Start a service tool** from the System Service Tools (SST) display and press Enter.
5. Select **Hardware service manager** from the Start a Service Tool display and press Enter.
6. Select **Work with service action log** from the Hardware Service Manager display and press Enter.
7. On the Select Timeframe display, change the **From: Date and Time** field to a date and time prior to when the problem occurred.
8. Search for an entry that matches one or more conditions of the problem:
 - System Reference code
 - Resource
 - Date and time
 - Failing item list
9. Select option 2 (Display failing item information) to display the service action log entry.
10. Select option 2 (Display details) to display location information for the failing part to be replaced. The information displayed in the date and time fields is the date and time for the first occurrence of the specific System reference code for the resource displayed during the time range selected.
11. Select option 7 (Indicator off) to turn off the indicator light.
12. Select the **Acknowledge all errors** function at the bottom of the Service Action Log display, if all problems have been resolved.
13. Close the log entry by selecting option 8 (Close new entry) on the Service Action Log Report display.

Identifying a failing part in a Linux system or logical partition

If the service aids have been installed on a system or logical partition, you can activate or deactivate the indicator lights to locate a part or complete a service action.

Locating a failing part in a Linux system or logical partition:

If the service aids have been installed on a system or logical partition, you need to activate the indicator lights to locate a part.

To activate the indicator light, follow these steps:

1. Log in as root user.
2. At the command line, type `/usr/sbin/usysident -s identify -l<location code>` and press Enter.
3. Look for the system attention light to identify the enclosure that contains the failing part.

Related information

 [Service and productivity tools for Linux on POWER systems](#)

IBM provides hardware diagnostic aids and productivity tools, as well as installation aids for Linux operating systems on IBM Power systems.

Finding the location code of a failing part in a Linux system or logical partition:

To retrieve the location code of the failing part, if you do not know the location code, use the procedure in this topic.

To locate the failing part in a system or logical partition follow these steps:

1. Log in as root user.
2. At the command line, type `grep diagela /var/log/platform` and press Enter.
3. Look for the most recent entry that contains a system reference code (SRC).
4. Record the location information.

Note: IBM provides hardware diagnostic aids and productivity tools, as well as installation aids for Linux operating systems on IBM Power systems. See [Service and productivity tools for Linux on Power Systems servers](#)

Activating the indicator light for the failing part:

If you know the location code of the failing part, activate the indicator light to help you locate which part to replace.

To activate the indicator light, follow these steps:

1. Log in as root user.
2. At the command line, type `/usr/sbin/usysident -s identify -l<location code>` and press Enter.
3. Look for the system attention light to identify the enclosure that contains the failing part.

Note: IBM provides hardware diagnostic aids and productivity tools, as well as installation aids for Linux operating systems on IBM Power systems. See [Service and productivity tools for Linux on Power Systems servers](#)

Deactivating the failing-part indicator light:

After you complete a removal and replacement procedure, you must deactivate the failing-part indicator light.

To deactivate the indicator light, follow these steps:

1. Log in as root user.
2. At the command line, type `/usr/sbin/usysident -s normal -l<location code>` and press Enter.

Note: IBM provides hardware diagnostic aids and productivity tools, as well as installation aids for Linux operating systems on IBM Power systems. See *Service and productivity tools for Linux on Power Systems servers*

Locating a failing part in a Virtual I/O Server system or logical partition

You can use Virtual I/O Server (VIOS) tools, before activating the indicator light, to locate a part that is failing.

1. Log in as root user or `celogin-`.
2. At the command line, type `diagmenu` and press Enter.
3. From the **Function Selection** menu, select **Task Selection** and press Enter.
4. Select **Display Previous Diagnostic Results** and press Enter.
5. From the **Display Previous Diagnostic Results** display, select **Display Diagnostic Log Summary**. A **Display Diagnostic Log** display appears. This display contains a chronological list of events.
6. Look in the **T** column for the most recent **S** entry. Select this row in the table and press Enter.
7. Choose **Commit**. The details of this log entry are shown.
8. Record the location information and the SRN value shown near the end of the entry.
9. Exit to the command line.

Use the location information for the failing part to activate the indicator light that identifies the failing part. For instructions, see “Identifying a part by using the Virtual I/O Server.”

Identifying a part by using the Virtual I/O Server:

Use these instructions to turn on the indicator light to help you physically locate a part by using the Virtual I/O Server (VIOS).

1. Log in as root user.
2. At the command line, type `diagmenu` and press Enter.
3. From the Function Selection menu, select **Task Selection**. Press Enter.
4. From the Task Selection menu, select **Identify and Attention Indicators**. Press Enter.
5. From the list of lights, select the location code for the failing part and press Enter.
6. Select **Commit**. This turns on the system attention and indicator light for the failing part.
7. Exit to the command line.

Starting the system or logical partition

Learn how to start a system or logical partition after performing a service action or system upgrade.

Starting a system that is not managed by an HMC or an SDMC

You can use the power button or the Advanced System Management Interface to start a system that is not managed by a Hardware Management Console or an IBM Systems Director Management Console.

To start a system that is not managed by a Hardware Management Console (HMC) or Systems Director Management Console (SDMC), follow these steps:

1. Open the front rack door, if necessary.
2. Before you press the power button on the control panel, ensure that power is connected to the system unit as follows:
 - All system power cables are connected to a power source.
 - The power-on light, as shown in the following figure, is slowly blinking.

- The top of the display, as shown in the following figure, shows 01 V=F.
3. Press the power button (A), as shown in the following figure, on the control panel.

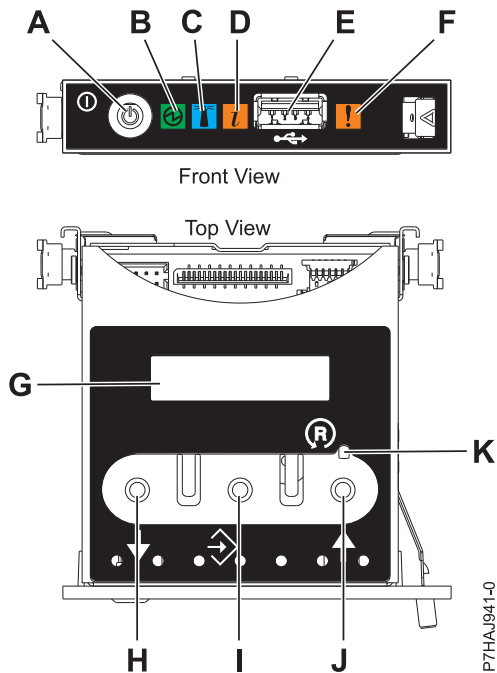

Figure 86. Control panel

- A: Power-on button
- B: Power LED
 - A constant light indicates full system power to the unit.
 - A blinking light indicates standby power to the unit.
- Note:** There is approximately a 30-second transition period from the time the power-on button is pressed to when the power LED goes from blinking to solid. During the transition period, the LED might blink faster.
- C: Enclosure identify light
 - A constant light indicates the identify state, which is used to identify a part.
 - No light indicates that the system is operating normally.
- D: Attention light
 - No light indicates that the system is operating normally.
 - A blinking light indicates that the system requires attention.
- E: USB port
- F: Enclosure fault roll-up light
 - A constant light indicates a fault in the system.
 - No light indicates that the system is operating normally.
- G: Function/Data display
- H: Decrement button
- I: Enter button
- J: Increment button
- K: Pinhole reset button

4. Observe the following after pressing the power button:

- The power-on light begins to blink faster.
- The system cooling fans are activated after approximately 30 seconds and begin to accelerate to operating speed.
- Progress indicators, also referred to as checkpoints, appear on the control panel display while the system is being started. The power-on light on the control panel stops blinking and remains on, indicating that system power is on.

Tip: If pressing the power button does not start the system, do the following steps to start the system using the Advanced System Management Interface (ASMI):

1. Access the ASMI. For instructions, see [Accessing the ASMI](#).
2. Start the system using the ASMI. For instructions, see [Powering the system on and off](#).

Starting a system or logical partition by using the Hardware Management Console

You can use the Hardware Management Console (HMC) user interface to start the system or logical partition after the required cables are installed and the power cables are connected to a power source.

For instructions on working with the HMC, see [Managing the Hardware Management Console](#). For instructions on starting a logical partition, see [Logical partitioning](#). For instructions on starting the system, see [Powering on the managed system](#).

Progress indicators, also referred to as checkpoints, appear on the control panel display while the system is being started. When the power-on light on the control panel stops blinking and remains on, the system power is on.

Stopping a system or logical partition

Learn how to stop a system or logical partition as a part of a system upgrade or service action.

Attention: Using either the power-on button on the control panel or entering commands at the Hardware Management Console (HMC) to stop the system can cause unpredictable results in the data files. Also, the next time you start the system, it might take longer if all applications are not ended before stopping the system.

To stop the system or logical partition, select the appropriate procedure.

Related tasks

Shutting down logical partitions using the Integrated Virtualization Manager

Use this procedure to shut down a logical partition or the entire managed system that is managed using the Integrated Virtualization Manager.

Stopping a system that is not managed by an HMC or an SDMC

You might need to stop the system to perform another task. Use these instructions to stop the system using the power button or Advanced System Management Interface.

Before you stop the system, follow these steps:

1. If an Integrated xSeries® Adapter (IXA) is present on the system, shut it down using IBM i options.
2. Ensure that all jobs are completed and end all applications.
3. Ensure that the operating system is stopped.

Attention: Failure to do so can result in the loss of data.

4. If a Virtual I/O Server (VIOS) logical partition is running, ensure that all clients are shut down or that the clients have access to their devices using an alternate method.

The following procedure describes how to stop a system that is not managed by a Hardware Management Console (HMC).

1. Log in to the system as a user with the authority to run the shutdown or pwrdownsys (Power Down System) command.
2. At the command line, enter one of the following commands:
 - If your system is running the AIX operating system, type shutdown.
 - If your system is running the Linux operating system, type shutdown -h now.
 - If your system is running the IBM i operating system, type PWRDWN SYS. If your system is partitioned, use the PWRDWN SYS command to power down each of the secondary partitions. Then, use the PWRDWN SYS command to power down the primary partition.

The command stops the operating system. The system power turns off, the power-on light begins to slowly flash, and the system goes into a standby state.

3. Record the IPL type and the IPL mode from the control panel display to help you return the system to this state when the installation or replacement procedure is completed.
4. Set the power switches of any devices connected to the system to off.
5. Unplug any power cables that are attached to the unit from electrical outlets. Ensure that you unplug power cables from peripheral devices, such as printers and expansion units.

Important: The system is equipped with a second power supply. Before continuing with this procedure, ensure that all power sources to the system have been disconnected.

(L003)

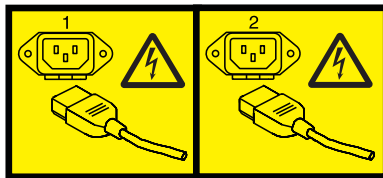

or



Stopping a system by using the Hardware Management Console

You can use the Hardware Management Console (HMC) user interface to stop the system or a logical partition. Use the following steps to accomplish this task.

By default, the managed system is set to power off automatically when you shut down the last running logical partition on the managed system. If you set the managed system properties on the HMC so that the managed system does not power off automatically, you must use this procedure to power off your managed system.

Attention: If possible, shut down the running logical partitions on the managed system before powering off the managed system. Powering off the managed system without shutting down the logical partitions first causes the logical partitions to shut down abnormally and can cause data loss. If you use a Virtual I/O Server (VIOS) logical partition, ensure that all clients are shut down or that the clients have access to their devices using an alternate method.

To power off a managed system, you must be a member of one of the following roles:

- Super administrator
 - Service representative
 - Operator
 - Product engineer
1. In the Navigation area, expand the **Systems Management** folder.
 2. Click the **Servers** icon.
 3. In the Contents area, select the managed system.
 4. Select **Tasks**, then **Operations**, and then **Power Off**
 5. Select the appropriate power-off mode and click **OK**.

Related information

 Shutting down and restarting logical partitions

Installing a feature by using the Hardware Management Console

You can use the Hardware Management Console to perform many service actions, including the installation of a new feature or part.

To use the Hardware Management Console user interface to install a feature or part into a system or expansion unit that is managed by an HMC, follow these steps:

1. In the navigation area, expand **Systems Management** → **Servers**.
2. Select the managed system you will install the part in.
3. In the Tasks area expand **Serviceability** → **Hardware** → **MES Tasks**.
4. Select **Add FRU** (field replaceable unit).
5. In the Add/Install/Remove Hardware window select the system or enclosure into which you are installing the feature.
6. Select the type of feature you are installing from the menu and click **Next**
7. Select the location code for where you will install the feature, and click **Add**.
8. After the FRU is placed in the **pending actions** category click **Launch Procedure** and follow the instructions to install the feature.

Note: The HMC might open external instructions for installing the feature. If so, follow those instructions to install the feature.

Removing a part by using the Hardware Management Console

You can use the Hardware Management Console (HMC) to perform many service actions, including the removal of a field replaceable unit (FRU) or part.

To use the Hardware Management Console user interface to remove a part in a system or expansion unit that is managed by an HMC, follow these steps:

1. In the navigation area, expand **Systems Management** → **Servers**.
2. Select the managed system from which you are removing a part.
3. Select one of the following options.
 - If you are installing a new part as part of an upgrade, in the Tasks area expand **Serviceability** → **Hardware** → **MES Tasks**.
 - If you are replacing a part as part of a service action, in the Tasks area expand **Serviceability** → **Hardware** → **Remove FRU**.
4. To install a new part as part of an upgrade, select **Add FRU**. To replace a part as part of a service action, select **Remove FRU**.
5. In the Add/Install/Remove Hardware - Remove FRU, Select FRU Type window, select the system or enclosure from which you are removing the part.
6. Select the type of part you are removing from the menu and click **Next**.
7. Select the location of the part you are removing and click **Add**.
8. After the part is listed in the **Pending Actions** display click **Launch Procedure** and follow the instructions to remove the part.

Note: The HMC might open the information center instructions for removing the part. If so, follow those instructions to remove the part.

Replacing a part by using the Hardware Management Console

You can use the Hardware Management Console (HMC) to perform many service actions, including exchanging a field replaceable unit (FRU) or part.

If you are exchanging a part to repair a serviceable event follow those instructions. If you are exchanging a part as a part of any other procedure using HMC Version 7 or later use these steps:

1. In the navigation area, expand **Systems Management** → **Servers**.
2. Select the managed system in which you are exchanging a part.
3. Select one of the following options.
 - If you are installing a new part as part of an upgrade, in the Tasks area expand **Serviceability** → **Hardware** → **MES Tasks**.
 - If you are replacing a part as part of a service action, in the Tasks area expand **Serviceability** → **Hardware** → **Exchange FRU**.
4. To install a new part as part of an upgrade, select **Add FRU**. To replace a part as part of a service action, select **Exchange FRU**.
5. In the Replace Hardware - Replace FRU, Select FRU Type window select the system or enclosure in which you will exchange a part from the list.
6. Select the type of part you will exchange from the menu and click **Next**.
7. Select the location code of the part you will exchange from the menu and click **Add**.
8. After the FRU is placed in the **pending actions** category click **Launch Procedure** and follow the instructions to exchange the feature.

Note: The HMC might open external instructions for replacing the part. If so, follow those instructions to replace the part.

Removing a part by using the Hardware Management Console

You can use the Hardware Management Console (HMC) to perform many service actions, including the removal of a field replaceable unit (FRU) or part.

To use the Hardware Management Console user interface to remove a part in a system or expansion unit that is managed by an HMC, follow these steps:

1. In the navigation area, expand **Systems Management** → **Servers**.

2. Select the managed system from which you are removing a part.
3. Select one of the following options.
 - If you are installing a new part as part of an upgrade, in the Tasks area expand **Serviceability** → **Hardware** → **MES Tasks**.
 - If you are replacing a part as part of a service action, in the Tasks area expand **Serviceability** → **Hardware** → **Remove FRU**.
4. To install a new part as part of an upgrade, select **Add FRU**. To replace a part as part of a service action, select **Remove FRU**.
5. In the Add/Install/Remove Hardware - Remove FRU, Select FRU Type window, select the system or enclosure from which you are removing the part.
6. Select the type of part you are removing from the menu and click **Next**.
7. Select the location of the part you are removing and click **Add**.
8. After the part is listed in the **Pending Actions** display click **Launch Procedure** and follow the instructions to remove the part.

Note: The HMC might open the information center instructions for removing the part. If so, follow those instructions to remove the part.

Replacing a part by using the Hardware Management Console

You can use the Hardware Management Console (HMC) to perform many service actions, including exchanging a field replaceable unit (FRU) or part.

If you are exchanging a part to repair a serviceable event follow those instructions. If you are exchanging a part as a part of any other procedure using HMC Version 7 or later use these steps:

1. In the navigation area, expand **Systems Management** → **Servers**.
2. Select the managed system in which you are exchanging a part.
3. Select one of the following options.
 - If you are installing a new part as part of an upgrade, in the Tasks area expand **Serviceability** → **Hardware** → **MES Tasks**.
 - If you are replacing a part as part of a service action, in the Tasks area expand **Serviceability** → **Hardware** → **Exchange FRU**.
4. To install a new part as part of an upgrade, select **Add FRU**. To replace a part as part of a service action, select **Exchange FRU**.
5. In the Replace Hardware - Replace FRU, Select FRU Type window select the system or enclosure in which you will exchange a part from the list.
6. Select the type of part you will exchange from the menu and click **Next**.
7. Select the location code of the part you will exchange from the menu and click **Add**.
8. After the FRU is placed in the **pending actions** category click **Launch Procedure** and follow the instructions to exchange the feature.

Note: The HMC might open external instructions for replacing the part. If so, follow those instructions to replace the part.

Verifying the installed part

You can verify a newly installed or replaced part on your system, logical partition, or expansion unit using the operating system, stand-alone diagnostics, or the Hardware Management Console (HMC).

Verifying an installed feature or replaced part in an AIX system or logical partition

If you installed feature or replaced a part, you might want to use the tools in AIX to verify that the feature or part is recognized by the system or logical partition.

To verify the operation of a newly installed feature or replacement part, select the appropriate procedure:

- Verify the installed feature using AIX
- Verifying the replaced part using AIX

Verify the installed feature by using AIX:

1. Log in as root user.
2. At the command line, type `diag` and press Enter.
3. Select **Advanced Diagnostics Routines** and press Enter.
4. From the **Diagnostic Mode Selection** menu, select **System Verification** and press Enter.
5. When the **Advanced Diagnostic Selection** menu appears, do one of the following:
 - To test a single resource, select the resource that you just installed from the list of resources and press Enter.
 - To test all the resources available to the operating system, select **All Resources** and press Enter.
6. Select **Commit**, and wait until the diagnostic programs run to completion, responding to any prompts that appear.
7. Did the diagnostics run to completion and display the message No trouble was found?
 - **No:** If a service request number (SRN) or other reference code is displayed, suspect a loose adapter or cable connection. Review the installation procedures to ensure that the new feature is installed correctly. If you cannot correct the problem, collect all SRNs or any other reference code information that you see. If the system is running in logical partitioning (LPAR) mode, note the logical partition in which you installed the feature. Contact your service provider for assistance.
 - **Yes:** The new device is installed correctly. Exit the diagnostic programs and return the system to normal operations.

Verify the replacement part by using AIX:

To verify the operation of a newly installed feature or replacement part, follow these steps:

1. Did you use either the AIX operating system or the online diagnostics service aid concurrent (hot-swap) service to replace the part?
 - No:** Go to step 2.
 - Yes:** Go to step 5 on page 113.
2. Is the system powered off?
 - No:** Go to step 4.
 - Yes:** If the system supports slow boot, set the system to perform a slow boot. For information, see *Performing a slow boot*.
3. Start the system and wait until the AIX operating system login prompt is displayed or until apparent system activity on the operator panel or display has stopped.

Did the AIX login prompt display?

 - **No:** If a service request number (SRN) or other reference code is displayed, suspect a loose adapter or cable connection. Review the procedures for the part that you replaced to ensure that the new part is installed correctly. If you cannot correct the problem, collect all SRNs or any other reference code information that you see. If the system does not start or you have no login prompt, see: *Problems with loading and starting the operating system*.

If the system is partitioned, note the logical partition in which you replaced the part. Contact your service provider for assistance.
 - **Yes:** Go to step 4.
4. At the command prompt, type `diag -a` and press Enter to check for missing resources. If you see a command prompt, go to step 5 on page 113.

If the **Diagnostic selection** menu is shown with **M** appearing next to any resource, follow these steps:

- a. Select the resource and press Enter.
 - b. Select **Commit**.
 - c. Follow any instructions that are shown.
 - d. If the *Do you want to review the previously displayed error?* message is shown, select **Yes** and press Enter.
 - e. If an SRN is shown, suspect a loose card or connection. If no obvious problem is shown, record the SRN and contact your service provider for assistance..
 - f. If no SRN is shown, go to step 5.
5. Test the part by doing the following steps:
- a. At the command line, type `diag` and press Enter.
 - b. From the **Function Selection** menu, select **Advanced Diagnostics Routines** and press Enter.
 - c. From the **Diagnostic Mode Selection** menu, select **System Verification** and press Enter.
 - d. Select **All Resources**, or select the diagnostics for the individual part to test only the part you replaced and any devices that are attached to the part you replaced and press Enter.
Did the **Resource Repair Action** menu appear?
No: Go to step 6.
Yes: Go to step 7.
6. Did the *Testing Complete, No trouble was found* message appear?
- **No:** There is still a problem. Contact your service provider. **This ends the procedure.**
 - **Yes:** Select **Log Repair Action**, if not previously logged, from the **Task Selection** menu to update the AIX error log. If the repair action was reseating a cable or adapter, select the resource associated with that repair action. If the resource associated with your action is not displayed on the resource list, select `sysplanar0` and press Enter.
- Tip:** This action changes the indicator light for the part from the fault state to the normal state. Go to step 9 on page 114.
7. Select the resource for the replaced part from the **Resource Repair Action** menu. When a test is run on a resource in system verification mode, and that resource has an entry in the AIX error log, if the test on the resource was successful, the **Resource Repair Action** menu appears. Complete the following steps to update the AIX error log to indicate that a system-detectable part has been replaced.
- Note:** On systems with an indicator light for the failing part, this action changes the indicator light to the normal state.
- a. Select the resource that has been replaced from the **Resource Repair Action** menu. If the repair action was reseating a cable or adapter, select the resource associated with that repair action. If the resource associated with your action does not appear on the resource list, select `sysplanar0` and press Enter.
 - b. Select **Commit** after you make your selections. Did another **Resource Repair Action** display appear?
No: If the **No Trouble Found** display appears, go to step 9 on page 114
Yes: Go to step 8.
8. Select the parent or child of the resource for the replaced part from the **Resource Repair Action** menu if necessary. When a test is run on a resource in system verification mode, and that resource has an entry in the AIX error log, if the test on the resource was successful, the **Resource Repair Action** menu appears. Complete the following steps to update the AIX error log to indicate that a system-detectable part has been replaced.

Note: This action changes the indicator light for the part from the fault state to the normal state.

- a. From the **Resource Repair Action** menu, select the parent or child of the resource that has been replaced. If the repair action was to reseal a cable or adapter, select the resource associated with that repair action. If the resource associated with your action does not appear on the resource list, select **sysplanar0** and press Enter.
 - b. Select **Commit** after you make your selections.
 - c. If the **No Trouble Found** display appears, go to step 9.
9. If you changed the service processor or network settings, as instructed in previous procedures, restore the settings to the values they had prior to servicing the system.
 10. Did you do any hot-plug procedures before doing this procedure?
No: Go to step 11.
Yes: Go to step 12.
 11. Start the operating system, with the system or logical partition in normal mode. Were you able to start the operating system?
No: Contact your service provider. **This ends the procedure.**
Yes: Go to step 12.
 12. Are the indicator lights still on?
 - **No. This ends the procedure.**
 - **Yes.** Turn off the lights. See the following for instructions: Changing service indicators.

Verifying the installed part in an IBM i system or logical partition

If you have installed a new feature or part, verify that the system recognizes the feature or part by using the IBM i system service tools.

To verify the installed part, follow these steps:

1. Deactivate the failing item indicator light. For instructions, see “Deactivating the failing-part indicator light” on page 103.
2. Sign on **with at least service level authority**.
3. On the command line of the IBM i session, type **strsst** and press Enter.

Note: If you cannot get to the System Service Tools display, use function 21 from the control panel. Alternatively, if the system is managed by Hardware Management Console (HMC), use the Service Focal Point Utilities to get to the Dedicated Service Tools (DST) display.

4. Type your service tools user ID and service tools password on the System Service Tools (SST) Sign On display and press Enter.

Note: The service tools password is case-sensitive.

5. Select **Start a service tool** from the System Service Tools (SST) display and press Enter.
6. Select **Hardware service manager** from the Start a Service Tool display and press Enter.
7. Select **Logical hardware resources (buses, IOPs, controllers)** from the Hardware Service Manager display and press Enter. This option allows you to display and work with logical resources. Logical hardware resources are the functional resources of the system used by the operating system.

With the Logical Hardware Resources display, you can show logical hardware resource status or information, and associated packaging hardware resources. Use the online Help information to better understand specific functions, fields, or symbols.

Deactivating the failing-part indicator light:

Use this procedure to turn off any indicator light that you turned on as a part of a service action.

To deactivate the indicator light, follow these steps:

1. Sign on to an IBM i session, **with at least service level authority**.
2. On the command line of the session, type `strsst` and press Enter.

Note: If you cannot get to the System Service Tools display, use function 21 from the control panel. Alternatively, if the system is managed by a Hardware Management Console (HMC), use the Service Focal Point utilities to get to the Dedicated Service Tools (DST) display.

3. Type your service tools user ID and service tools password on the System Service Tools (SST) Sign On display. Press Enter.

Remember: The service tools password is case-sensitive.

4. Select **Start a service tool** from the System Service Tools (SST) display and press Enter.
5. Select **Hardware service manager** from the Start a Service Tool display and press Enter.
6. Select **Work with service action log** from the Hardware Service Manager display and press Enter.
7. On the Select Timeframe display, change the **From: Date and Time** field to a date and time prior to when the problem occurred.
8. Search for an entry that matches one or more conditions of the problem:
 - System Reference code
 - Resource
 - Date and time
 - Failing item list
9. Select option 2 (Display failing item information) to display the service action log entry.
10. Select option 2 (Display details) to display location information for the failing part to be replaced. The information displayed in the date and time fields is the date and time for the first occurrence of the specific System reference code for the resource displayed during the time range selected.
11. Select option 7 (Indicator off) to turn off the indicator light.
12. Select the **Acknowledge all errors** function at the bottom of the Service Action Log display, if all problems have been resolved.
13. Close the log entry by selecting option 8 (Close new entry) on the Service Action Log Report display.

Verifying the installed part in a Linux system or logical partition

If you have installed a new part, learn how to verify that the system recognizes the part.

To verify the newly installed or replaced part, continue with “Verifying an installed part by using stand-alone diagnostics.”

Verifying an installed part by using stand-alone diagnostics

If you have installed or replaced a part, verify that the system recognizes the new part. You can use stand-alone diagnostics to verify an installed part in a Linux system, expansion unit, or logical partition.

- If this server is directly attached to another server or attached to a network, ensure communications with the other servers have stopped.
- The stand-alone diagnostics require use of all of the logical partition resources. No other activity can be running on the logical partition.
- The stand-alone diagnostics require access to the system console.

You access these diagnostics from a CD-ROM or from the Network Installation Management (NIM) server. This procedure describes how to use the diagnostics from a CD-ROM. For information on running diagnostics from the Network Installation Management (NIM) server, see Running stand-alone diagnostics from a Network Installation Management server.

To use stand-alone diagnostics, follow these steps:

1. Stop all jobs and applications and then stop the operating system on the system or logical partition.
2. Remove all tapes, diskettes, and CD-ROM.
3. Turn off the system unit power. The next step boots the server or logical partition from the stand-alone diagnostics CD-ROM. If the optical drive is not available as the boot device on the server or logical partition on which you are working, follow these steps:
 - a. Access the ASMI. See Accessing the ASMI for information on using the ASMI.
 - b. On the ASMI main menu, click on **Power/Restart Control**.
 - c. Click Power On/Off System.
 - d. Select the **Service mode boot from default boot list** option in the AIX or Linux logical partition mode boot drop-down menu.
 - e. Click **Save settings and power on**. As soon as the optical drive has power, insert the standalone diagnostic CD-ROM.
 - f. Go to step 5.
4. Turn on the system unit power and immediately insert the diagnostics CD-ROM into the optical drive.
5. After the **keyboard** POST indicator displays on the system console and before the last POST indicator (**speaker**) displays, press the numeric 5 key on the system console to indicate that a service mode boot should be initiated using the default-service mode boot list.
6. Enter any requested password.
7. At the **Diagnostic Operating Instructions** display, press Enter.

Tip: If a service request number (SRN) or other reference code is displayed, suspect a loose adapter or cable connection.

Note: If you received an SRN or any other reference code when you attempted to start the system, contact your service provider for assistance..

8. If the terminal type is requested, select the **Initialize Terminal** option on the Function Selection menu to initialize the operating system.
9. From the Function Selection menu, select **Advanced Diagnostics Routines** and press Enter.
10. From the Diagnostic Mode Selection menu, select **System Verification** and press Enter.
11. When the Advanced Diagnostic Selection menu appears, select **All Resources**, or test only the part you replaced, and any devices that are attached to the part you replaced, by selecting the diagnostics for the individual part and press Enter.
12. Did the Testing Complete, No trouble was found message appear?
 - **No:** There is still a problem. Contact your service provider.
 - **Yes:** Go to step 13.
13. If you changed the service processor or network settings, as instructed in previous procedures, restore the settings to the value they had prior to servicing the system.
14. If the indicator lights are still on, follow these steps:
 - a. Select **Identify and Attention Indicators** from the Task Selection menu to turn off the system attention and indicator lights and press Enter.
 - b. Select **Set System Attention Indicator to NORMAL** and press Enter.
 - c. Select **Set All Identify Indicators to NORMAL** and press Enter.
 - d. Choose **Commit**.

Note: This changes the system attention and identify indicators from the *Fault* state to the *Normal* state.

- e. Exit to the command line.

Verifying the installed part by using Hardware Management Console

If you have installed or replaced a part, use the Hardware Management Console (HMC) to update your HMC records after you have completed a service action on your server. If you have reference codes, symptoms, or location codes that you used during the service action, locate the records for use during this procedure.

To verify the installed part, complete these steps:

1. At the HMC, examine the service action event log for any open service action events. See “Viewing serviceable events by using the HMC” on page 118 for details.
2. Are there any service action events that are open?
 - No:** If the system attention LED is still on, use the HMC to turn off the LED. See “Activating and deactivating LEDs by using the HMC.” **This ends the procedure.**
 - Yes:** Continue with the next step.
3. Record the list of open service action events.
4. Examine the details of the open service action event. Is the error code associated with this service action event the same as you gathered earlier.
 - **No:** Select one of the following options:
 - Review the other serviceable events, find one that does match, and continue with the next step.
 - If the log does not match what you had gathered earlier, contact your service provider.
 - **Yes:** Continue with the next step.
5. Select and highlight the service action event from the Error Associated With This Serviceable Event window.
6. Click **Close Event**.
7. Add comments for the serviceable event. Include any unique additional information. Click **OK**.
8. Did you replace, add, or modify a field replaceable unit (FRU) of the open service action event?
 - **No:** Select the **No FRU Replaced for this Serviceable Event** option, and click **OK** to close the service action event.
 - **Yes:** Perform the following steps:
 - a. From the FRU list, select a FRU that you need to update.
 - b. Double-click the FRU and update the FRU information.
 - c. Click **OK** to close the service action event.
9. If you continue to have problems, contact your service provider.

Activating and deactivating LEDs by using the HMC:

Use this procedure to activate or deactivate LEDs using Service Focal Point for the Hardware Management Console (HMC).

Choose from the following:

- “Deactivating a system attention LED or partition LED”
- “Activating or deactivating identify LED” on page 118

Deactivating a system attention LED or partition LED:

You can deactivate a system attention LED or a logical partition LED. For example, you might determine that a problem is not a high priority and decide to repair the problem at a later time. However, you want to be alerted if another problem occurs, so you must deactivate the system attention LED so that it can be activated again if another problem occurs.

1. In the navigation area, open **Systems Management**.
2. Open **Servers** and select the appropriate system.

3. In the content area, check the box for the appropriate Partition.
4. Select **Tasks**, then **Operations**, and then **Manage Attention LED**.
5. Select the appropriate Partition.
6. Select **Deactivate System Attention LED** from the **Action** menu. A confirmation window is displayed that provides the following information:
 - A verification that the system attention LED was deactivated.
 - An indication that there still might be open problems within the system.
 - An indication that you cannot activate the system attention LED.
7. Select one of the logical partitions in the lower table, and select **Deactivate partition LED** from the **Partition Operations** menu. A confirmation window is displayed that provides the following information:
 - A verification that the logical partition LED was deactivated.
 - An indication that there still might be open problems within the logical partition.
 - An indication that you cannot activate the logical partition LED.

Activating or deactivating identify LED:

The system provides several LEDs that help identify various components, such as enclosures or field replaceable units (FRUs), in the system. For this reason, they are called *identify LEDs*.

You can activate or deactivate the following types of identify LEDs:

- **Identify LED for an enclosure** If you want to add an adapter to a specific drawer (enclosure), you need to know the machine type, model, and serial number (MTMS) of the drawer. To determine whether you have the correct MTMS for the drawer that needs the new adapter, you can activate the LED for a drawer and verify that the MTMS corresponds to the drawer that requires the new adapter.
- **Identify LED for a FRU associated with a specified enclosure** If you want to hook up a cable to a specific I/O adapter, you can activate the LED for the adapter which is a field replaceable unit (FRU), and then physically check to see where you should hook up the cable. This is especially useful when you have several adapters with open ports.

To activate or deactivate an identify LED for an enclosure or FRU, follow these steps:

1. In the navigation area, open **Systems Management**.
2. Select **Servers**.
3. In the content area, check the box for the appropriate System.
4. Select **Tasks**, then **Operations**, then **LED Status**, and then **Identify LED**.
5. To activate or deactivate an identify LED for an enclosure, select an enclosure from the table, and click either **Activate LED** or **Deactivate LED**. The associated LED is either turned on or off.
6. To activate or deactivate an identify LED for a FRU, select an enclosure from the table, select **Selected** → **List FRUs**.
7. Select one or more FRUs from the table, and click either **Activate LED** or **Deactivate LED**. The associated LED is either turned on or off.

Viewing serviceable events by using the HMC:

Use this procedure to view a serviceable event, including details, comments, and service history.

To view serviceable events and other information about the events, you must be a member of one of the following roles:

- Super administrator
- Service representative
- Operator

- Product engineer
- Viewer

To view serviceable events, follow these steps:

1. In the navigation area, select **Service Management**.
2. Select **Manage Serviceable Events**.
3. Select the criteria for the serviceable events that you want to view, and click **OK**. The Serviceable Event Overview window opens. The list shows all serviceable events that match your selection criteria. You can use the menu options to perform actions on the serviceable events.
4. Select a line in the Serviceable Event Overview window, and select **Selected** → **View Details**. The Serviceable Event Details window opens, showing detailed information about the serviceable event. The upper table shows information, such as problem number and reference code. The lower table shows the field replaceable units (FRUs) associated with this event.
5. Select the error for which you want to view comments and history, and follow these steps:
 - a. Select **Actions** → **View Comments**.
 - b. When you are finished viewing the comments, click **Close**.
 - c. Select **Actions** → **View Service History**. The Service History window opens, showing service history associated with the selected error.
 - d. When you are finished viewing the service history, click **Close**.
6. When you are finished, click **Cancel** twice to close the Serviceable Event Details window and the Serviceable Event Overview window.

Verifying an installed feature or replaced part on a system or logical partition by using Virtual I/O Server tools

If you installed feature or replaced a part, you might want to use the tools in Virtual I/O Server (VIOS) to verify that the feature or part is recognized by the system or logical partition.

To verify the operation of a newly installed feature or replacement part, select the appropriate procedure:

- Verify the installed feature using VIOS
- Verifying the replaced part using VIOS

Verify the installed feature by using VIOS:

1. Log in as root user.
2. At the command line, type `diagmenu` and press Enter.
3. Select **Advanced Diagnostics Routines** and press Enter.
4. From the **Diagnostic Mode Selection** menu, select **System Verification** and press Enter.
5. When the **Advanced Diagnostic Selection** menu appears, do one of the following:
 - To test a single resource, select the resource that you just installed from the list of resources and press Enter.
 - To test all the resources available to the operating system, select **All Resources** and press Enter.
6. Select **Commit**, and wait until the diagnostic programs run to completion, responding to any prompts that appear.
7. Did the diagnostics run to completion and display the message `No trouble was found?`
 - **No:** If a service request number (SRN) or other reference code is displayed, suspect a loose adapter or cable connection. Review the installation procedures to ensure that the new feature is installed correctly. If you cannot correct the problem, collect all SRNs or any other reference code information that you see. If the system is running in LPAR mode, note the logical partition in which you installed the feature. Contact your service provider for assistance.
 - **Yes:** The new device is installed correctly. Exit the diagnostic programs and return the system to normal operations.

Verify the replacement part by using VIOS:

To verify the operation of a newly installed feature or replacement part, follow these steps:

1. Did you replace the part by using either VIOS or the online diagnostics service aid's concurrent (hot-swap) service operation?

No: Go to step 2.

Yes: Go to step 5.

2. Is the system powered off?

No: Go to step 4.

Yes: If the system supports slow boot, set the system to perform a slow boot. For information, see *Performing a slow boot*.

3. Start the system and wait until the VIOS operating system login prompt displays or until apparent system activity on the operator panel or display has stopped.

Did the VIOS login prompt display?

- **No:** If an SRN or other reference code is displayed, suspect a loose adapter or cable connection. Review the procedures for the part that you replaced to ensure that the new part is installed correctly. If you cannot correct the problem, collect all SRNs or any other reference code information that you see. If the system does not start or you have no login prompt, see: *Problems with loading and starting the operating system*.

If the system is partitioned, note the logical partition in which you replaced the part. Contact your service provider for assistance.

- **Yes:** Go to step 4

4. At the command prompt, type `diag -a` and press Enter to check for missing resources. If you see a command prompt, go to step 5.

If the **Diagnostic selection** menu is shown with **M** appearing next to any resource, follow these steps:

- a. Select the resource and press Enter.
- b. Select **Commit**.
- c. Follow any instructions that are shown.
- d. If a *Do you want to review the previously displayed error?* message is shown, select **Yes** and press Enter.
- e. If an SRN is shown, suspect a loose card or connection. If no obvious problem is shown, record the SRN and contact your service provider for assistance..
- f. If no SRN is shown, go to 5.

5. Test the part by doing the following:

- a. At the command line, type `diagmenu` and press Enter.
- b. From the **Function Selection** menu, select **Advanced Diagnostics Routines** and press Enter.
- c. From the **Diagnostic Mode Selection** menu, select **System Verification** and press Enter.
- d. Select **All Resources**, or select the diagnostics for the individual part to test only the part you replaced, and any devices that are attached to the part you replaced and press Enter.

Did the **Resource Repair Action** menu appear?

No: Go to step 6.

Yes: Go to step 7 on page 121.

6. Did the *Testing Complete, No trouble was found* message appear?

- **No:** There is still a problem. Contact your service provider. **This ends the procedure.**
- **Yes:** Select **Log Repair Action**, if not previously logged, from the **Task Selection** menu to update the AIX error log. If the repair action was reseating a cable or adapter, select the resource

associated with that repair action. If the resource associated with your action is not displayed on the Resource List, select **sysplanar0** and press Enter.

Tip: This action changes the indicator light for the part from the fault state to the normal state.
Go to step 9

7. Select the resource for the replaced part from the **Resource Repair Action** menu. When a test is run on a resource in system verification mode, and that resource has an entry in the AIX error log, if the test on the resource was successful, the **Resource Repair Action** menu appears. Complete the following steps to update the AIX error log to indicate that a system-detectable part has been replaced.

Note: On systems with a indicator light for the failing part, this changes the indicator light to the normal state.

- a. Select the resource that has been replaced from the **Resource Repair Action** menu. If the repair action was reseating a cable or adapter, select the resource associated with that repair action. If the resource associated with your action does not appear on the Resource List, select **sysplanar0**. Press Enter.
- b. Select **Commit** after you make your selections. Did another **Resource Repair Action** display appear?

No: If the **No Trouble Found** display appears, go to step 9

Yes: Go to step 8.

8. Select the parent or child of the resource for the replaced part from the **Resource Repair Action** menu if necessary. When a test is run on a resource in system verification mode, and that resource has an entry in the AIX error log, if the test on the resource was successful, the **Resource Repair Action** menu appears. Complete the following steps to update the AIX error log to indicate that a system-detectable part has been replaced.

Note: This changes the indicator light for the part from the fault state to the normal state.

- a. From the **Resource Repair Action** menu, select the parent or child of the resource that has been replaced. If the repair action was to reseat a cable or adapter, select the resource associated with that repair action. If the resource associated with your action does not appear on the Resource List, select **sysplanar0**. Press Enter.
 - b. Select **Commit** after you make your selections.
 - c. If the **No Trouble Found** display appears, go to step 9.
9. If you changed the service processor or network settings, as instructed in previous procedures, restore the settings to the values they had prior to servicing the system.
 10. Did you do any hot-plug procedures before doing this procedure?
No: Go to step 11.
Yes: Go to step 12.
 11. Start the operating system, with the system or logical partition in normal mode. Were you able to start the operating system?
No: Contact your service provider. **This ends the procedure.**
Yes: Go to step 12.
 12. Are the indicator lights still on?
 - **No. This ends the procedure.**
 - **Yes.** Turn off the lights. See one of the following for instructions: Changing service indicators

Notices

This information was developed for products and services offered in the U.S.A.

The manufacturer may not offer the products, services, or features discussed in this document in other countries. Consult the manufacturer's representative for information on the products and services currently available in your area. Any reference to the manufacturer's product, program, or service is not intended to state or imply that only that product, program, or service may be used. Any functionally equivalent product, program, or service that does not infringe any intellectual property right of the manufacturer may be used instead. However, it is the user's responsibility to evaluate and verify the operation of any product, program, or service.

The manufacturer may have patents or pending patent applications covering subject matter described in this document. The furnishing of this document does not grant you any license to these patents. You can send license inquiries, in writing, to the manufacturer.

The following paragraph does not apply to the United Kingdom or any other country where such provisions are inconsistent with local law: THIS INFORMATION IS PROVIDED "AS IS" WITHOUT WARRANTY OF ANY KIND, EITHER EXPRESS OR IMPLIED, INCLUDING, BUT NOT LIMITED TO, THE IMPLIED WARRANTIES OF NON-INFRINGEMENT, MERCHANTABILITY OR FITNESS FOR A PARTICULAR PURPOSE. Some states do not allow disclaimer of express or implied warranties in certain transactions, therefore, this statement may not apply to you.

This information could include technical inaccuracies or typographical errors. Changes are periodically made to the information herein; these changes will be incorporated in new editions of the publication. The manufacturer may make improvements and/or changes in the product(s) and/or the program(s) described in this publication at any time without notice.

Any references in this information to websites not owned by the manufacturer are provided for convenience only and do not in any manner serve as an endorsement of those websites. The materials at those websites are not part of the materials for this product and use of those websites is at your own risk.

The manufacturer may use or distribute any of the information you supply in any way it believes appropriate without incurring any obligation to you.

Any performance data contained herein was determined in a controlled environment. Therefore, the results obtained in other operating environments may vary significantly. Some measurements may have been made on development-level systems and there is no guarantee that these measurements will be the same on generally available systems. Furthermore, some measurements may have been estimated through extrapolation. Actual results may vary. Users of this document should verify the applicable data for their specific environment.

Information concerning products not produced by this manufacturer was obtained from the suppliers of those products, their published announcements or other publicly available sources. This manufacturer has not tested those products and cannot confirm the accuracy of performance, compatibility or any other claims related to products not produced by this manufacturer. Questions on the capabilities of products not produced by this manufacturer should be addressed to the suppliers of those products.

All statements regarding the manufacturer's future direction or intent are subject to change or withdrawal without notice, and represent goals and objectives only.

The manufacturer's prices shown are the manufacturer's suggested retail prices, are current and are subject to change without notice. Dealer prices may vary.

This information is for planning purposes only. The information herein is subject to change before the products described become available.

This information contains examples of data and reports used in daily business operations. To illustrate them as completely as possible, the examples include the names of individuals, companies, brands, and products. All of these names are fictitious and any similarity to the names and addresses used by an actual business enterprise is entirely coincidental.

If you are viewing this information in softcopy, the photographs and color illustrations may not appear.

The drawings and specifications contained herein shall not be reproduced in whole or in part without the written permission of the manufacturer.

The manufacturer has prepared this information for use with the specific machines indicated. The manufacturer makes no representations that it is suitable for any other purpose.

The manufacturer's computer systems contain mechanisms designed to reduce the possibility of undetected data corruption or loss. This risk, however, cannot be eliminated. Users who experience unplanned outages, system failures, power fluctuations or outages, or component failures must verify the accuracy of operations performed and data saved or transmitted by the system at or near the time of the outage or failure. In addition, users must establish procedures to ensure that there is independent data verification before relying on such data in sensitive or critical operations. Users should periodically check the manufacturer's support websites for updated information and fixes applicable to the system and related software.

Ethernet connection usage restriction

This product is not intended to be connected directly or indirectly by any means whatsoever to interfaces of public telecommunications networks.

Trademarks

IBM, the IBM logo, and ibm.com are trademarks or registered trademarks of International Business Machines Corp., registered in many jurisdictions worldwide. Other product and service names might be trademarks of IBM or other companies. A current list of IBM trademarks is available on the Web at Copyright and trademark information at www.ibm.com/legal/copytrade.shtml.

Linux is a registered trademark of Linus Torvalds in the United States, other countries, or both.

Other product or service names might be trademarks of IBM or other companies.

Electronic emission notices

When attaching a monitor to the equipment, you must use the designated monitor cable and any interference suppression devices supplied with the monitor.

Class A Notices

The following Class A statements apply to the IBM servers that contain the POWER7 processor and its features unless designated as electromagnetic compatibility (EMC) Class B in the feature information.

Federal Communications Commission (FCC) statement

Note: This equipment has been tested and found to comply with the limits for a Class A digital device, pursuant to Part 15 of the FCC Rules. These limits are designed to provide reasonable protection against harmful interference when the equipment is operated in a commercial environment. This equipment

generates, uses, and can radiate radio frequency energy and, if not installed and used in accordance with the instruction manual, may cause harmful interference to radio communications. Operation of this equipment in a residential area is likely to cause harmful interference, in which case the user will be required to correct the interference at his own expense.

Properly shielded and grounded cables and connectors must be used in order to meet FCC emission limits. IBM is not responsible for any radio or television interference caused by using other than recommended cables and connectors or by unauthorized changes or modifications to this equipment. Unauthorized changes or modifications could void the user's authority to operate the equipment.

This device complies with Part 15 of the FCC rules. Operation is subject to the following two conditions: (1) this device may not cause harmful interference, and (2) this device must accept any interference received, including interference that may cause undesired operation.

Industry Canada Compliance Statement

This Class A digital apparatus complies with Canadian ICES-003.

Avis de conformité à la réglementation d'Industrie Canada

Cet appareil numérique de la classe A est conforme à la norme NMB-003 du Canada.

European Community Compliance Statement

This product is in conformity with the protection requirements of EU Council Directive 2004/108/EC on the approximation of the laws of the Member States relating to electromagnetic compatibility. IBM cannot accept responsibility for any failure to satisfy the protection requirements resulting from a non-recommended modification of the product, including the fitting of non-IBM option cards.

This product has been tested and found to comply with the limits for Class A Information Technology Equipment according to European Standard EN 55022. The limits for Class A equipment were derived for commercial and industrial environments to provide reasonable protection against interference with licensed communication equipment.

European Community contact:
IBM Deutschland GmbH
Technical Regulations, Department M456
IBM-Allee 1, 71139 Ehningen, Germany
Tele: +49 7032 15-2937
email: tjahn@de.ibm.com

Warning: This is a Class A product. In a domestic environment, this product may cause radio interference, in which case the user may be required to take adequate measures.

VCCI Statement - Japan

この装置は、クラスA情報技術装置です。この装置を家庭環境で使用すると電波妨害を引き起こすことがあります。この場合には使用者が適切な対策を講ずるよう要求されることがあります。

VCCI-A

The following is a summary of the VCCI Japanese statement in the box above:

This is a Class A product based on the standard of the VCCI Council. If this equipment is used in a domestic environment, radio interference may occur, in which case, the user may be required to take corrective actions.

Japanese Electronics and Information Technology Industries Association (JEITA) Confirmed Harmonics Guideline (products less than or equal to 20 A per phase)

高調波ガイドライン適合品

Japanese Electronics and Information Technology Industries Association (JEITA) Confirmed Harmonics Guideline with Modifications (products greater than 20 A per phase)

高調波ガイドライン準用品

Electromagnetic Interference (EMI) Statement - People's Republic of China

声 明

此为 A 级产品,在生活环境中,
该产品可能会造成无线电干扰。
在这种情况下,可能需要用户对其
干扰采取切实可行的措施。

Declaration: This is a Class A product. In a domestic environment this product may cause radio interference in which case the user may need to perform practical action.

Electromagnetic Interference (EMI) Statement - Taiwan

警告使用者：

這是甲類的資訊產品，在
居住的環境中使用時，可
能會造成射頻干擾，在這
種情況下，使用者會被要
求採取某些適當的對策。

The following is a summary of the EMI Taiwan statement above.

Warning: This is a Class A product. In a domestic environment this product may cause radio interference in which case the user will be required to take adequate measures.

IBM Taiwan Contact Information:

台灣IBM 產品服務聯絡方式：
台灣國際商業機器股份有限公司
台北市松仁路7號3樓
電話：0800-016-888

Electromagnetic Interference (EMI) Statement - Korea

이 기기는 업무용(A급)으로 전자파적합기기로서 판매자 또는 사용자는 이 점을 주의하시기 바라며, 가정외의 지역에서 사용하는 것을 목적으로 합니다.

Germany Compliance Statement

Deutschsprachiger EU Hinweis: Hinweis für Geräte der Klasse A EU-Richtlinie zur Elektromagnetischen Verträglichkeit

Dieses Produkt entspricht den Schutzanforderungen der EU-Richtlinie 2004/108/EG zur Angleichung der Rechtsvorschriften über die elektromagnetische Verträglichkeit in den EU-Mitgliedsstaaten und hält die Grenzwerte der EN 55022 Klasse A ein.

Um dieses sicherzustellen, sind die Geräte wie in den Handbüchern beschrieben zu installieren und zu betreiben. Des Weiteren dürfen auch nur von der IBM empfohlene Kabel angeschlossen werden. IBM übernimmt keine Verantwortung für die Einhaltung der Schutzanforderungen, wenn das Produkt ohne Zustimmung von IBM verändert bzw. wenn Erweiterungskomponenten von Fremdherstellern ohne Empfehlung von IBM gesteckt/eingebaut werden.

EN 55022 Klasse A Geräte müssen mit folgendem Warnhinweis versehen werden:

"Warnung: Dieses ist eine Einrichtung der Klasse A. Diese Einrichtung kann im Wohnbereich Funk-Störungen verursachen; in diesem Fall kann vom Betreiber verlangt werden, angemessene Maßnahmen zu ergreifen und dafür aufzukommen."

Deutschland: Einhaltung des Gesetzes über die elektromagnetische Verträglichkeit von Geräten

Dieses Produkt entspricht dem "Gesetz über die elektromagnetische Verträglichkeit von Geräten (EMVG)". Dies ist die Umsetzung der EU-Richtlinie 2004/108/EG in der Bundesrepublik Deutschland.

Zulassungsbescheinigung laut dem Deutschen Gesetz über die elektromagnetische Verträglichkeit von Geräten (EMVG) (bzw. der EMC EG Richtlinie 2004/108/EG) für Geräte der Klasse A

Dieses Gerät ist berechtigt, in Übereinstimmung mit dem Deutschen EMVG das EG-Konformitätszeichen - CE - zu führen.

Verantwortlich für die Einhaltung der EMV Vorschriften ist der Hersteller:
International Business Machines Corp.
New Orchard Road
Armonk, New York 10504
Tel: 914-499-1900

Der verantwortliche Ansprechpartner des Herstellers in der EU ist:
IBM Deutschland GmbH
Technical Regulations, Abteilung M456
IBM-Allee 1, 71139 Ehningen, Germany
Tel: +49 7032 15-2937
email: tjahn@de.ibm.com

Generelle Informationen:

Das Gerät erfüllt die Schutzanforderungen nach EN 55024 und EN 55022 Klasse A.

Electromagnetic Interference (EMI) Statement - Russia

**ВНИМАНИЕ! Настоящее изделие относится к классу А.
В жилых помещениях оно может создавать
радиопомехи, для снижения которых необходимы
дополнительные меры**

Terms and conditions

Permissions for the use of these publications is granted subject to the following terms and conditions.

Personal Use: You may reproduce these publications for your personal, noncommercial use provided that all proprietary notices are preserved. You may not distribute, display or make derivative works of these publications, or any portion thereof, without the express consent of the manufacturer.

Commercial Use: You may reproduce, distribute and display these publications solely within your enterprise provided that all proprietary notices are preserved. You may not make derivative works of these publications, or reproduce, distribute or display these publications or any portion thereof outside your enterprise, without the express consent of the manufacturer.

Except as expressly granted in this permission, no other permissions, licenses or rights are granted, either express or implied, to the publications or any information, data, software or other intellectual property contained therein.

The manufacturer reserves the right to withdraw the permissions granted herein whenever, in its discretion, the use of the publications is detrimental to its interest or, as determined by the manufacturer, the above instructions are not being properly followed.

You may not download, export or re-export this information except in full compliance with all applicable laws and regulations, including all United States export laws and regulations.

THE MANUFACTURER MAKES NO GUARANTEE ABOUT THE CONTENT OF THESE PUBLICATIONS. THESE PUBLICATIONS ARE PROVIDED "AS-IS" AND WITHOUT WARRANTY OF ANY KIND, EITHER EXPRESSED OR IMPLIED, INCLUDING BUT NOT LIMITED TO IMPLIED WARRANTIES OF MERCHANTABILITY, NON-INFRINGEMENT, AND FITNESS FOR A PARTICULAR

PURPOSE.

