

Escala BL460

Problem Determination and Service Guide

ESCALA Blade



REFERENCE
86 A7 81FB 00

ESCALA Blade

Escala BL460

Problem Determination and Service Guide

Hardware

October 2009

BULL CEDOC
357 AVENUE PATTON
B.P.20845
49008 ANGERS CEDEX 01
FRANCE

REFERENCE
86 A7 81FB 00

The following copyright notice protects this book under Copyright laws which prohibit such actions as, but not limited to, copying, distributing, modifying, and making derivative works.

Copyright © Bull SAS 2009

Printed in France

Suggestions and criticisms concerning the form, content, and presentation of this book are invited. A form is provided at the end of this book for this purpose.

To order additional copies of this book or other Bull Technical Publications, you are invited to use the Ordering Form also provided at the end of this book.

Trademarks and Acknowledgements

We acknowledge the rights of the proprietors of the trademarks mentioned in this manual.

All brand names and software and hardware product names are subject to trademark and/or patent protection.

Quoting of brand and product names is for information purposes only and does not represent trademark misuse.

The information in this document is subject to change without notice. Bull will not be liable for errors contained herein, or for incidental or consequential damages in connection with the use of this material.

Table of Contents

List of Figures.....	iv
List of Tables	v
Safety	vii
Safety statements.....	viii
Guidelines for trained service technicians.....	xiv
Inspecting for unsafe conditions	xiv
Guidelines for servicing electrical equipment	xv
Chapter 1. Introduction	1
1.1 Related documentation.....	1
1.2 Notices and statements in this documentation	2
1.3 Features and specifications.....	3
1.4 Supported DIMMs	5
1.5 Blade server control panel buttons and LEDs.....	7
1.6 Turning on the blade server	10
1.7 Turning off the blade server	11
1.8 System-board layouts.....	12
1.9 System-board connectors.....	12
1.10 System-board LEDs	14
Chapter 2. Diagnostics	15
2.1 Diagnostic tools	16
2.2 Collecting dump data	17
2.3 Location codes.....	18
2.4 Reference codes.....	19
2.4.1 System reference codes (SRCs)	20
2.4.2 POST progress codes (checkpoints).....	71
2.4.3 Service request numbers (SRNs).....	109
2.5 Error logs	147
2.6 Checkout procedure	148
2.6.1 About the checkout procedure	148
2.6.2 Performing the checkout procedure	149

2.7	Verifying the partition configuration.....	152
2.8	Running the diagnostics program	152
2.8.1	Starting AIX concurrent diagnostics	152
2.8.2	Starting stand-alone diagnostics from a CD	152
2.8.3	Starting stand-alone diagnostics from a NIM server.....	153
2.8.4	Using the diagnostics program	155
2.9	Boot problem resolution.....	156
2.10	Troubleshooting tables	158
2.10.1	General problems	158
2.10.2	Drive problems	158
2.10.3	Intermittent problems.....	159
2.10.4	Keyboard problems.....	159
2.10.5	Management module service processor problems	160
2.10.6	Memory problems	161
2.10.7	Microprocessor problems.....	161
2.10.8	Monitor or video problems	162
2.10.9	Network connection problems	163
2.10.10	PCI expansion card (PIOCARD) problem isolation procedure	164
2.10.11	Optional device problems	165
2.10.12	Power problems	165
2.10.13	POWER® Hypervisor (PHYP) problems.....	167
2.10.14	Service processor problems	169
2.10.15	Software problems	181
2.10.16	Universal Serial Bus (USB) port problems	181
2.11	Light path diagnostics	182
2.11.1	Viewing the light path diagnostic LEDs.....	182
2.11.2	Light path diagnostics LEDs.....	184
2.12	Firmware problem isolation	185
2.13	Recovering the system firmware	186
2.13.1	Starting the PERM image.....	186
2.13.2	Starting the TEMP image	186
2.13.3	Recovering the TEMP image from the PERM image.....	187
2.13.4	Verifying the system firmware levels	187
2.13.5	Committing the TEMP system firmware image.....	188
2.14	Solving shared Bull Blade Chassis – Enterprise resource problems.....	188
2.14.1	Solving shared keyboard problems	189
2.14.2	Solving shared media tray problems.....	190
2.14.3	Solving shared network connection problems	192
2.14.4	Solving shared power problems.....	193
2.14.5	Solving shared video problems	193
2.15	Solving undetermined problems	194
2.16	Calling Bull for service	196
Chapter 3.	Parts listing.....	197

Chapter 4.	Removing and replacing blade server components	201
4.1	Installation guidelines	201
4.1.2	System reliability guidelines	202
4.1.3	Handling static-sensitive devices	202
4.1.4	Returning a device or component.....	203
4.2	Removing the blade server from a Bull Blade Chassis - Enterprise.....	203
4.3	Installing the blade server in a Bull Blade Chassis - Enterprise.....	204
4.4	Removing and replacing Tier 1 CRUs	206
4.4.1	Removing the blade server cover	206
4.4.2	Installing and closing the blade server cover	208
4.4.3	Removing the bezel assembly.....	209
4.4.4	Installing the bezel assembly	210
4.4.5	Removing a drive.....	211
4.4.6	Installing a drive	212
4.4.7	Removing a memory module	213
4.4.8	Installing a memory module.....	214
4.4.9	Removing the management card.....	216
4.4.10	Installing the management card	217
4.4.11	Removing and installing an I/O expansion card.....	219
4.4.12	Removing the battery.....	224
4.4.13	Installing the battery	225
4.4.14	Removing the disk drive tray	227
4.4.15	Installing the hard disk drive tray	228
4.5	Replacing the Tier 2 system-board and chassis assembly	229
Chapter 5.	Configuring	231
5.1	Updating the firmware.....	231
5.2	Configuring the blade server	233
5.3	Using the SMS utility.....	234
5.3.1	Starting the SMS utility.....	234
5.3.2	SMS utility menu choices	234
5.4	Creating a CE login	235
5.5	Configuring the Gigabit Ethernet controllers	235
5.6	Blade server Ethernet controller enumeration	236
5.7	MAC addresses for host Ethernet adapters	237
5.8	Updating IBM System Director	238
Appendix A.	Getting help and technical assistance	239
	Before you call.....	239
	Using the documentation	239

Appendix B. Notices	241
Important Notes	241
Product recycling and disposal.....	242
Electronic emission notices.....	243
Industry Canada Class A emission compliance statement	243
Australia and New Zealand Class A statement	243
United Kingdom telecommunications safety requirement.....	243
European Union EMC Directive conformance statement	244
Taiwanese Class A warning statement	244
Chinese Class A warning statement	244
Japanese Voluntary Control Council for Interference (VCCI) statement.....	244

List of Figures

Figure 1-1.	DIMM connectors	6
Figure 1-2.	Blade server control panel buttons and LEDs	7
Figure 1-3.	System-board connectors	12
Figure 1-4.	DIMM connectors	13
Figure 1-5.	System-board LEDs	14
Figure 2-1.	Light path diagnostic LEDs.....	183
Figure 3-1.	Parts illustration	197
Figure 4-1.	Removing the blade server from the Bull Blade Chassis - Enterprise	203
Figure 4-2.	Installing the blade server in a Bull Blade Chassis - Enterprise	204
Figure 4-3.	Removing the cover.....	206
Figure 4-4.	Installing the cover	208
Figure 4-5.	Removing the bezel assembly.....	209
Figure 4-6.	Installing the bezel assembly	210
Figure 4-7.	Removing a SAS hard disk.....	211
Figure 4-8.	Installing a SAS hard disk.....	212
Figure 4-9.	DIMM connectors	213
Figure 4-10.	DIMM connectors	214
Figure 4-11.	Removing the management card.....	216
Figure 4-12.	Installing the management card	217
Figure 4-13.	Removing a CIOv form factor expansion card from the 1Xe connector	219
Figure 4-14.	Installing a CIOv form-factor expansion card.....	220
Figure 4-15.	Removing a combination-form-factor expansion card.....	222
Figure 4-16.	Installing a combination-form-factor expansion card.....	223
Figure 4-17.	Removing the battery.....	224
Figure 4-18.	Installing the battery	225
Figure 4-19.	Removing the hard disk drive tray.....	227
Figure 4-20.	Installing the hard disk drive tray	228

List of Tables

Table 1-1.	Memory module combinations	5
Table 1-2.	Connectors description.....	12
Table 1-3.	System-board LEDs locations	14
Table 2-1.	Location code	18
Table 2-2.	Nine-word system reference code in the management-module event log.....	20
Table 2-3.	Management module reference code listing.....	20
Table 2-4.	1xxxxxxx SRCs	22
Table 2-5.	6xxxxxxx SRCs	26
Table 2-6.	A1xxxxxx service processor SRCs.....	27
Table 2-7.	A200yyyy Logical partition SRCs	27
Table 2-8.	A700yyyy Licensed internal code SRCs.....	28
Table 2-9.	AA00E1A8 to AA260005 Partition firmware attention codes.....	28
Table 2-10.	<i>B181xxxx Service processor early termination SRCs</i>	30
Table 2-11.	B200xxxx Logical partition SRCs.....	31
Table 2-12.	B700xxxx Licensed internal code SRCs	39
Table 2-13.	BA000010 to BA400002 Partition firmware SRCs.....	45
Table 2-14.	Management module reference code listing.....	71
Table 2-15.	C1001F00 to C1645300 checkpoints.....	72
Table 2-16.	C2001000 to C20082FF checkpoints	79
Table 2-17.	C700xxxx Server firmware IPL status checkpoints	85
Table 2-18.	CA000000 to CA2799FF checkpoints.....	85
Table 2-19.	D1001xxx to D1xx3FFF dump codes	101
Table 2-20.	D1xx3y01 to D1xx3yF2 checkpoints	105
Table 2-21.	D1xx900C to D1xxC003 checkpoints	107
Table 2-22.	101-711 through FFC-725 SRNs.....	110
Table 2-23.	Meaning of the last character (x) after the hyphen	127
Table 2-24.	A00-FF0 through A24-xxx SRNs.....	127
Table 2-25.	ssss-102 through ssss-640 SRNs	141
Table 2-26.	Failing function codes 151 through 2D02	144
Table 2-27.	Nine-word system reference code in the management-module event log.....	147
Table 2-28.	Nine-word system reference code in the management-module event log.....	164
Table 2-29.	PCI expansion card problem isolation procedure.....	164
Table 2-30.	POWER® Hypervisor isolation procedures	167
Table 2-31.	. Light path diagnostic LED descriptions.....	184
Table 3-1.	Parts table	198
Table 4-1.	Memory module combination.....	214
Table 5-1.	MAC addressing scheme for physical and logical host Ethernet adapters.....	237

Safety

Before installing this product, read the Safety Information.

قبل تركيب هذا المنتج، يجب قراءة الملاحظات الأمنية

Antes de instalar este produto, leia as Informações de Segurança.

在安装本产品之前，请仔细阅读 **Safety Information** (安全信息)。

安裝本產品之前，請先閱讀「安全資訊」。

Prije instalacije ovog produkta obavezno pročitajte Sigurnosne Upute.

Před instalací tohoto produktu si přečtěte příručku bezpečnostních instrukcí.

Læs sikkerhedsforskrifterne, før du installerer dette produkt.

Lees voordat u dit product installeert eerst de veiligheidsvoorschriften.

Ennen kuin asennat tämän tuotteen, lue turvaohjeet kohdasta Safety Information.

Avant d'installer ce produit, lisez les consignes de sécurité.

Vor der Installation dieses Produkts die Sicherheitshinweise lesen.

Πριν εγκαταστήσετε το προϊόν αυτό, διαβάστε τις πληροφορίες ασφάλειας (safety information).

לפני שתתקינו מוצר זה, קראו את הוראות הבטיחות.

A termék telepítése előtt olvassa el a Biztonsági előírásokat!

Prima di installare questo prodotto, leggere le Informazioni sulla Sicurezza.

製品の設置の前に、安全情報をお読みください。

본 제품을 설치하기 전에 안전 정보를 읽으십시오.

Пред да се инсталира овој продукт, прочитајте информацијата за безбедност.

Les sikkerhetsinformasjonen (Safety Information) før du installerer dette produktet.

Przed zainstalowaniem tego produktu, należy zapoznać się z książką "Informacje dotyczące bezpieczeństwa" (Safety Information).

Antes de instalar este produto, leia as Informações sobre Segurança.

Перед установкой продукта прочтите инструкции по технике безопасности.

Pred inštaláciou tohto zariadenia si pečítajte Bezpečnostné predpisy.

Pred namestitvijo tega proizvoda preberite Varnostne informacije.

Antes de instalar este producto, lea la información de seguridad.

Läs säkerhetsinformationen innan du installerar den här produkten.

Safety statements

Important:

Each caution and danger statement in this documentation begins with a number. This number is used to cross reference an English-language caution or danger statement with translated versions of the caution or danger statement in the *Bull Safety Attention document*.

For example, if a caution statement begins with a number 1, translations for that caution statement appear in the *Bull Safety Attention document* under statement 1.

Be sure to read all caution and danger statements in this documentation before performing the instructions. Read any additional Safety Attention that comes with your computer or optional device before you install the device.

Statement 1:



DANGER

Electrical current from power, telephone, and communication cables is hazardous.

To avoid a shock hazard:

- Do not connect or disconnect any cables or perform installation, maintenance, or reconfiguration of this product during an electrical storm.
- Connect all power cords to a properly wired and grounded electrical outlet.
- Connect to properly wired outlets any equipment that will be attached to this product.
- When possible, use one hand only to connect or disconnect signal cables.
- Never turn on any equipment when there is evidence of fire, water, or structural damage.
- Disconnect the attached power cords, telecommunications systems, networks, and modems before you open the device covers, unless instructed otherwise in the installation and configuration procedures.
- Connect and disconnect cables as described in the following table when installing, moving, or opening covers on this product or attached devices.

To Connect:

1. Turn everything OFF.
2. First, attach all cables to devices.
3. Attach signal cables to connectors.
4. Attach power cords to outlet.
5. Turn device ON.

To Disconnect:

1. Turn everything OFF.
2. First, remove power cords from outlet.
3. Remove signal cables from connectors.
4. Remove all cables from devices.

Statement 2:



CAUTION:

When replacing the lithium battery, use a battery recommended by the manufacturer. If your system has a module containing a lithium battery, replace it only with the same module type made by the same manufacturer. The battery contains lithium and can explode if not properly used, handled or disposed of.

Do not:

- Throw or immerse into water
- Heat to more than 100°C (212°F)
- Repair or disassemble

Dispose of the battery as required by local ordinances or regulations.

Statement 3:



CAUTION:

When laser products (such as CD-ROMs, DVD drives, fiber optic devices, or transmitters) are installed, note the following:

- Do not remove the covers. Removing the covers of the laser product could result in exposure to hazardous laser radiation. There are no serviceable parts inside the device.
- Use of controls or adjustments or performance of procedures other than those specified herein might result in hazardous radiation exposure.



DANGER

Some laser products contain an embedded Class 3A or Class 3B laser diode. Note the following.

Laser radiation when open. Do not stare into the beam, do not view directly with optical instruments, and avoid direct exposure to the beam.

Class 1 Laser Product
Laser Klasse 1
Laser Klass 1
Luokan 1 Laserlaitte
Appareil À Laser de Classe 1

Statement 4:



≥ 18 kg (39.7 lb)



≥ 32 kg (70.5 lb)



≥ 55 kg (121.2 lb)

CAUTION:
Use safe practices when lifting.

Statement 5:



CAUTION:
The power control button on the device and the power switch on the power supply do not turn off the electrical current supplied to the device. The device also might have more than one power cord. To remove all electrical current from the device, ensure that all power cords are disconnected from the power source.

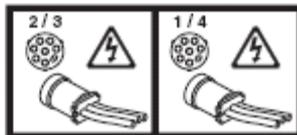

Statement 8:



CAUTION:

Never remove the cover on a power supply or any part that has the following label attached.



Hazardous voltage, current, and energy levels are present inside any component that has this label attached. There are no serviceable parts inside these components. If you suspect a problem with one of these parts, contact a service technician.

Statement 12:



CAUTION:

The following label indicates a hot surface nearby.



Statement 13:



DANGER

Overloading a branch circuit is potentially a fire hazard and a shock hazard under certain conditions. To avoid these hazards, ensure that your system electrical requirements do not exceed branch circuit protection requirements. Refer to the information that is provided with your device for electrical specifications.

Statement 20:



CAUTION:

To avoid personal injury, before lifting the unit, remove all the blades to reduce the weight.

Statement 21:



CAUTION:

Hazardous energy is present when the blade is connected to the power source. Always replace the blade cover before installing the blade.

WARNING: Handling the cord on this product or cords associated with accessories sold with this product, will expose you to lead, a chemical known to the State of California to cause cancer, and birth defects or other reproductive harm. ***Wash hands after handling.***

ADVERTENCIA: El contacto con el cable de este producto o con cables de accesorios que se venden junto con este producto, pueden exponerle al plomo, un elemento químico que en el estado de California de los Estados Unidos está considerado como un causante de cáncer y de defectos congénitos, además de otros riesgos reproductivos. ***Lávese las manos después de usar el producto.***

Guidelines for trained service technicians

This section contains information for trained service technicians.

Inspecting for unsafe conditions

Use the information in this section to help you identify potential unsafe conditions in a Bull product that you are working on. Each Bull product, as it was designed and manufactured, has required safety items to protect users and service technicians from injury. The information in this section addresses only those items. Use good judgment to identify potential unsafe conditions that might be caused by non-Bull alterations or attachment of non-Bull features or options that are not addressed in this section. If you identify an unsafe condition, you must determine how serious the hazard is and whether you must correct the problem before you work on the product.

Consider the following conditions and the safety hazards that they present:

- Electrical hazards, especially primary power. Primary voltage on the frame can cause serious or fatal electrical shock.
- Explosive hazards, such as a damaged CRT face or a bulging capacitor.
- Mechanical hazards, such as loose or missing hardware.

To inspect the product for potential unsafe conditions, complete the following steps:

1. Make sure that the power is off and the power cords are disconnected.
2. Make sure that the exterior cover is not damaged, loose, or broken, and observe any sharp edges.
3. Check the power cords:
 - Make sure that the third-wire ground connector is in good condition. Use a meter to measure third-wire ground continuity for 0.1 ohm or less between the external ground pin and the frame ground.
 - Make sure that the power cords are the correct type.
 - Make sure that the insulation is not frayed or worn.
4. Remove the cover.
5. Check for any obvious non-Bull alterations. Use good judgment as to the safety of any non-Bull alterations.
6. Check inside the computer for any obvious unsafe conditions, such as metal filings, contamination, water or other liquid, or signs of fire or smoke damage.
7. Check for worn, frayed, or pinched cables.
8. Make sure that the power-supply cover fasteners (screws or rivets) have not been removed or tampered with.

Guidelines for servicing electrical equipment

Observe the following guidelines when servicing electrical equipment:

- Check the area for electrical hazards such as moist floors, nongrounded power extension cords, and missing safety grounds.
- Use only approved tools and test equipment. Some hand tools have handles that are covered with a soft material that does not provide insulation from live electrical current.
- Regularly inspect and maintain your electrical hand tools for safe operational condition. Do not use worn or broken tools or testers.
- Do not touch the reflective surface of a dental mirror to a live electrical circuit. The surface is conductive and can cause personal injury or equipment damage if it touches a live electrical circuit.
- Some rubber floor mats contain small conductive fibers to decrease electrostatic discharge. Do not use this type of mat to protect yourself from electrical shock.
- Do not work alone under hazardous conditions or near equipment that has hazardous voltages.
- Locate the emergency power-off (EPO) switch, disconnecting switch, or electrical outlet so that you can turn off the power quickly in the event of an electrical accident.
- Disconnect all power before you perform a mechanical inspection, work near power supplies, or remove or install main units.
- Before you work on the equipment, disconnect the power cord. If you cannot disconnect the power cord, have the customer power-off the wall box that supplies power to the equipment and lock the wall box in the off position.
- Never assume that power has been disconnected from a circuit. Check it to make sure that it has been disconnected.
- If you have to work on equipment that has exposed electrical circuits, observe the following precautions:
 - Make sure that another person who is familiar with the power-off controls is near you and is available to turn off the power if necessary.
 - When you are working with powered-on electrical equipment, use only one hand. Keep the other hand in your pocket or behind your back to avoid creating a complete circuit that could cause an electrical shock.
 - When using a tester, set the controls correctly and use the approved probe leads and accessories for that tester.
 - Stand on a suitable rubber mat to insulate you from grounds such as metal floor strips and equipment frames.
- Use extreme care when measuring high voltages.
- To ensure proper grounding of components such as power supplies, pumps, blowers, fans, and motor generators, do not service these components outside of their normal operating locations.
- If an electrical accident occurs, use caution, turn off the power, and send another person to get medical aid.

Chapter 1. Introduction

In this document, “Blade Chassis” or “Bull Blade Chassis - Enterprise” stand for “Bull Blade Chassis - Enterprise”.

This problem determination and service information helps you solve problems that might occur in your Escala BL460 blade server.

The information describes the diagnostic tools that come with the blade server, error codes and suggested actions, and instructions for replacing failing components.

Replaceable components are of three types:

- **Tier 1 customer replaceable unit (CRU):** Replacement of Tier 1 CRUs is your responsibility. If Bull installs a Tier 1 CRU at your request, you will be charged for the installation.
- **Tier 2 customer replaceable unit:** You may install a Tier 2 CRU yourself or request Bull to install it, at no additional charge, under the type of warranty service that is designated for your blade server.
- **Field replaceable unit (FRU):** FRUs must be installed only by trained service technicians.

For information about the terms of the warranty and getting service and assistance, see the *Bull Hardware Product Warranty* document.

1.1 Related documentation

Documentation for the Escala BL460 blade server includes documents in Portable Document Format (PDF) on the *Bull Blade Resource DVD*. You can find the following documents in PDF on the *Bull Blade Resource DVD*:

[Installation and User's Guide](#)

This document contains general information about the blade server, including how to install supported options and how to configure the blade server.

[Safety Attention](#)

This document contains translated caution and danger statements. Each caution and danger statement that appears in the documentation has a number that you can use to locate the corresponding statement in the *Safety Attention* document.

[Bull Hardware Product Warranty](#)

This document contains information about the terms of the warranty and about getting service and assistance.

Blade Serial over LAN Setup Guide

This document explains how to update and configure Blade components for Serial over LAN (SOL) operation. The SOL connection provides access to the text-based console command prompt on each blade server and enables the blade servers to be managed from a remote location.

Additional documents might be included on the Bull Blade Resource DVD.

The blade server might have features that are not described in the documentation that comes with the blade server. Review the *Planning Guide* and the *Installation Guide* for your Bull Blade Chassis - Enterprise. The information can help you prepare for system installation and configuration.

1.2 Notices and statements in this documentation

The caution and danger statements in this document are also in the *Safety Attention* document. Each statement is numbered for reference to the corresponding statement in the *Safety Attention* document.

The following notices and statements are used in this document:

Note: These notices provide important tips, guidance, or advice.



Important:

These notices provide information or advice that might help you avoid inconvenient or problem situations.



Attention:

These notices indicate potential damage to programs, devices, or data. An attention notice is placed just before the instruction or situation in which damage might occur.



CAUTION:

These statements indicate situations that can be potentially hazardous to you. A caution statement is placed just before the description of a potentially hazardous procedure step or situation.



DANGER:

These statements indicate situations that can be potentially lethal or extremely hazardous to you. A danger statement is placed just before the description of a potentially lethal or extremely hazardous procedure step or situation.

1.3 Features and specifications

Features and specifications of the Escala BL460 blade server are summarized in this overview.

The Escala BL460 blade server is used in a Bull Blade Chassis - Enterprise.

-
- Notes**
- Power, cooling, removable-media drives, external ports, and advanced system management are provided by the Bull Blade Chassis - Enterprise.
 - The operating system in the blade server must provide support for the Universal Serial Bus (USB), to enable the blade server to recognize and communicate internally with the removable-media drives and front-panel USB ports
-

Microprocessor:

- Dual core, dual socket (4-way) processors @ 4.2 GHz (DCM),
- 64 GB maximum in 8 very low profile (VLP) DIMM slots; supports 2 GB, 4 GB, and 8 GB DDR52 VLP DIMMs,
- 1 internal small-form-factor (SFF) Serial Attached SCSI (SAS) hard drive or Solid State Drive (SSD).

P5IOC2 I/O hub on-board integrated features:

- The baseboard management controller (BMC) is a flexible service processor (FSP1) with Intelligent Platform Management Interface (IPMI), Serial over LAN (SOL), and Wake on LAN (WOL) firmware support,
- Two 1 GB Ethernet controllers (HEA) connected to the Bull Blade Chassis - Enterprise fabric through the 5-port integrated Ethernet switch,
- SAS RAID 0/1/5 controller,
- 2D ATI Graphics (KVM support),
- USB 2.0.

Integrated functions:

- RS-485 interface for communication with the management module,
- Automatic server restart (ASR),
- Serial over LAN (SOL) through FSP,
- Four Universal Serial Bus (USB 2.0) buses on base planar for communication with keyboard and removable-media drives,
- Support for USB-attached local keyboard, video, and mouse (KVM),
- Transferable Anchor function (Renesas Technology HD651330 microcontroller) in the management card,
- Optical media available by shared chassis feature.

Daughter card I/O options:

- 1 1Xe expansion card: CFFv, or CIOv,
- 1 PCIe High speed expansion card - CFFh.

Electrical input: 12 V dc

Environment:

- Air temperature:
 - Blade server on: 10° to 35°C (50° to 95°F). Altitude: 0 to 914 m (3000 ft)
 - Blade server on: 10° to 32°C (50° to 90°F). Altitude: 914 m to 2133 m (3000 ft to 7000 ft)
 - Blade server off: -40° to 60°C (-40° to 140°F)
- Humidity:
 - Blade server on: 8% to 80%
 - Blade server off: 8% to 80%

Size:

- Height: 24.5 cm (9.7 inches)
- Depth: 44.6 cm (17.6 inches)
- Width: 2.9 cm (1.14 inches)
- Maximum weight: 5.0 kg (11 lb)

System management:

- Supported by Bull Blade Chassis - Enterprise management module,
- Front panel LEDs,
- Light path diagnostics,
- IBM Director,
- Cluster Systems Management (CSM),
- Energy Scale thermal management for power management/oversubscription (throttling) and environmental sensing.

Cluster support for:

- eCluster 1350,
- Cluster Systems Management,
- High-performance computing (HPC) Open Software Stack.

Virtualization support for:

PowerVM™ Standard Edition hardware feature, which provides the Integrated Virtualization Manager and Virtual I/O Server Partition Migration

Reliability and service features:

- Dual alternating current power supply,
- Bull Blade Chassis - Enterprise redundant and hot plug power and cooling modules,
- Predictive Failure Analysis® (PFA) alerts for the microprocessor and memory,
- Boot-time processor deallocation,
- Blade server hot plug,
- Customer setup and expansion,
- Automatic reboot on power loss,
- Internal and ambient temperature monitors,
- ECC, chipkill memory,
- System management alerts.

1.4 Supported DIMMs

The planar in the Escala BL460 blade server contains eight very low profile (VLP) memory connectors for registered dual inline memory modules (RDIMMs). The total memory capacity ranges from a minimum of 4 GB to a maximum of 64 GB for a BL460 blade server.

See *Chapter 3. Parts listing*, on page 197 for memory modules that you can order.

Memory module rules:

- Install DIMM fillers in unused DIMM slots for proper cooling.
- Install DIMMs in pairs (1 and 3, 6 and 8, 2 and 4, 5 and 7 for the BL460).
- Both DIMMs in a pair must be the same size, speed, type, and technology. You can mix compatible DIMMs from different manufacturers.
- Each DIMM within a processor-support group (1-4, 5-8) must be the same size and speed.
- Install only supported DIMMs.
- Installing or removing DIMMs changes the configuration of the blade server. After you install or remove a DIMM, the blade server is automatically reconfigured, and the new configuration information is stored.
- See *System-board connectors* on page 12 for DIMM connector locations.

Table 1-1 shows allowable placement of DIMM modules.

DIMM count	BL460 Blade planar (P1) DIMM slots							
	1	2	3	4	5	6	7	8
2	X		X					
4	X		X			X		X
6	X	X	X	X		X		X
8	X	X	X	X	X	X	X	X

Table 1-1. Memory module combinations

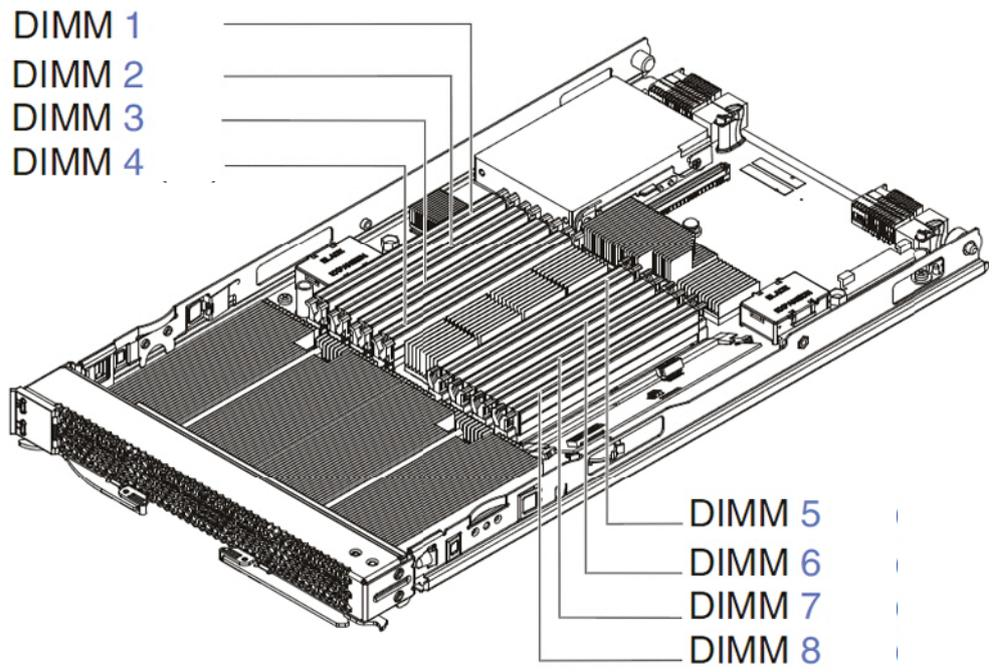

Figure 1-1. DIMM connectors

1.5 Blade server control panel buttons and LEDs

Blade server control panel buttons and LEDs provide operational controls and status indicators.

Note The following figure shows the control panel door in the closed (normal) position. To access the power-control button, you must open the control panel door.

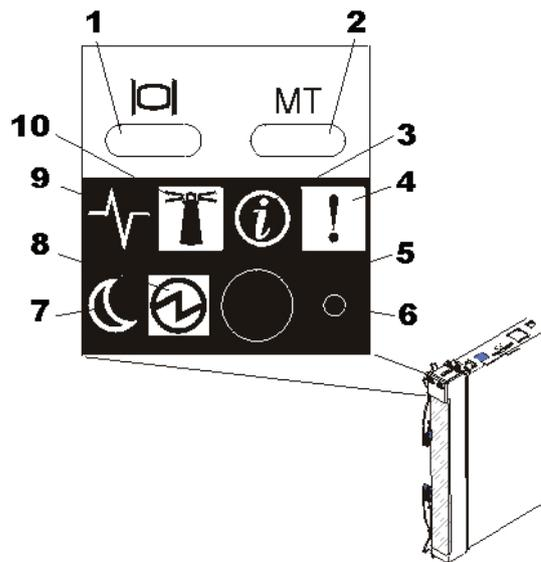

Figure 1-2. Blade server control panel buttons and LEDs

1 Keyboard/video select button:

When you use an operating system that supports a local console and keyboard, press this button to associate the shared Bull Blade Chassis - Enterprise keyboard and video ports with the blade server.

-
- Notes**
- The operating system in the blade server must provide USB support for the blade server to recognize and use the keyboard, even if the keyboard has a PS/2-style connector.
 - The keyboard and video are available after partition firmware loads and is running. Power-on self-test (POST) codes and diagnostics are not supported using the keyboard and video. Use the management module to view checkpoints.
-

The LED on this button flashes while the request is being processed, then is lit when the ownership of the keyboard and video has been transferred to the blade server. It can take approximately 20 seconds to switch control of the keyboard and video to the blade server.

Using a keyboard that is directly attached to the management module, you can press keys in the following sequence to switch keyboard and video control between blade servers:

NumLock NumLock *blade_server_number* Enter

Where *blade_server_number* is the two-digit number for the blade bay in which the blade server is installed. When you use some keyboards, such as the 28L3644 (37L0888) keyboard, hold down the Shift key while you enter this key sequence.

If there is no response when you press the keyboard/video select button, you can use the Web interface of the management module to determine whether local control has been disabled on the blade server.

2 Media-tray select button:

Press this button to associate the shared Bull Blade Chassis - Enterprise media tray (removable-media drives and front-panel USB ports) with the blade server. The LED on the button flashes while the request is being processed, then is lit when the ownership of the media tray has been transferred to the blade server. It can take approximately 20 seconds for the operating system in the blade server to recognize the media tray.

If there is no response when you press the media-tray select button, use the management module to determine whether local control has been disabled on the blade server.

Note The operating system in the blade server must provide USB support for the blade server to recognize and use the removable-media drives and USB ports.

3 Information LED:

When this amber LED is lit, it indicates that information about a system error for the blade server has been placed in the management-module event log. The information LED can be turned off through the Web interface of the management module or through IBM System Director Console.

4 Blade-error LED:

When this amber LED is lit, it indicates that a system error has occurred in the blade server. The blade-error LED will turn off after one of the following events:

- Correcting the error.
- Reseating the blade server in the Bull Blade Chassis - Enterprise.
- Cycling the Bull Blade Chassis - Enterprise power.

5 Power-control button:

This button is behind the control panel door. Press this button to turn on or turn off the blade server.

The power-control button has effect only if local power control is enabled for the blade server. Local power control is enabled and disabled through the Web interface of the management module.

Press the power button for 5 seconds to begin powering down the blade server.

6 NMI reset (recessed):

The nonmaskable interrupt (NMI) reset dumps the partition. Use this recessed button only as directed by Bull Support.

7 Sleep:

This LED is not used in the Escala Blade family.

8 Power-on LED:

This green LED indicates the power status of the blade server in the following manner:

- Flashing rapidly: The service processor (BMC) is initializing the blade server.
- Flashing slowly: The blade server has completed initialization and is waiting for a power-on command.
- Lit continuously: The blade server has power and is turned on.

Note The enhanced service processor can take as long as three minutes to initialize after you install the Escala BL460 blade server, at which point the LED begins to flash slowly.

9 Activity LED:

When this green LED is lit, it indicates that there is activity on the hard disk drive or network.

10 Location LED:

When this blue LED is lit, it has been turned on by the system administrator to aid in visually locating the blade server. The location LED can be turned off through the Web interface of the management module or through IBM System Director Console.

1.6 Turning on the blade server

After you connect the blade server to power through the Bull Blade Chassis - Enterprise, you can start the blade server after the discovery and initialization process is complete.

You can start the blade server in any of the following ways.

- Start the blade server by pressing the power-control button on the front of the blade server.

The power-control button is behind the control panel door, as described in *Blade server control panel buttons and LEDs* on page 7.

After you push the power-control button, the power-on LED continues to blink slowly for about 15 seconds, then is lit solidly when the power-on process is complete.

Wait until the power-on LED on the blade server flashes slowly before you press the blade server power-control button. If the power-on LED is flashing rapidly, the service processor in the management module is initializing. The power-control button does not respond during initialization.

Note The enhanced service processor can take as long as three minutes to initialize after you install the Escala BL460 blade server, at which point the LED begins to flash slowly.

While the blade server is starting, the power-on LED on the front of the blade server is lit. *Blade server control panel buttons and LEDs* on page 7 describes each LED state during power-on.

- Start the blade server automatically when power is restored after a power failure. If a power failure occurs, the Bull Blade Chassis - Enterprise and then the blade server can start automatically when power is restored. You must configure the blade server to restart through the management module.
- Start the blade server remotely using the management module. After you initiate the power-on process, the power-on LED blinks slowly for about 15 seconds, then is lit solidly when the power-on process is complete.

1.7 Turning off the blade server

When you turn off the blade server, it is still connected to power through the Bull Blade Chassis - Enterprise. The blade server can respond to requests from the service processor, such as a remote request to turn on the blade server. To remove all power from the blade server, you must remove it from the Bull Blade Chassis - Enterprise.

Shut down the operating system before you turn off the blade server. See the operating-system documentation for information about shutting down the operating system.

You can turn off the blade server in one of the following ways.

- Turn off the blade server by pressing the power-control button for at least 5 seconds. The power-control button is on the blade server behind the control panel door. See *Blade server control panel buttons and LEDs* on page 7 for the location.

Note The power-control LED can remain on solidly for up to 1 minute after you push the power-control button. After you turn off the blade server, wait until the power-control LED is blinking slowly before you press the power-control button to turn on the blade server again

If the operating system stops functioning, press and hold the power-control button for more than 5 seconds to force the blade server to turn off.

- Use the management module to turn off the blade server. The power-control LED can remain on solidly for up to 1 minute after you initiate the power-off process. After you turn off the blade server, wait until the power-control LED is blinking slowly before you initiate the power-on process from the AMM to turn on the blade server again. Use the management-module Web interface to configure the management module to turn off the blade server if the system is not operating correctly. For additional information, see the *User's Guide* for the management module.

1.8 System-board layouts

The following illustrations show the connectors and LEDs on the system board. The illustrations might differ slightly from your hardware.

1.9 System-board connectors

Blade server components attach to the connectors on the system board. The following figure shows the connectors on the system board in the blade server.

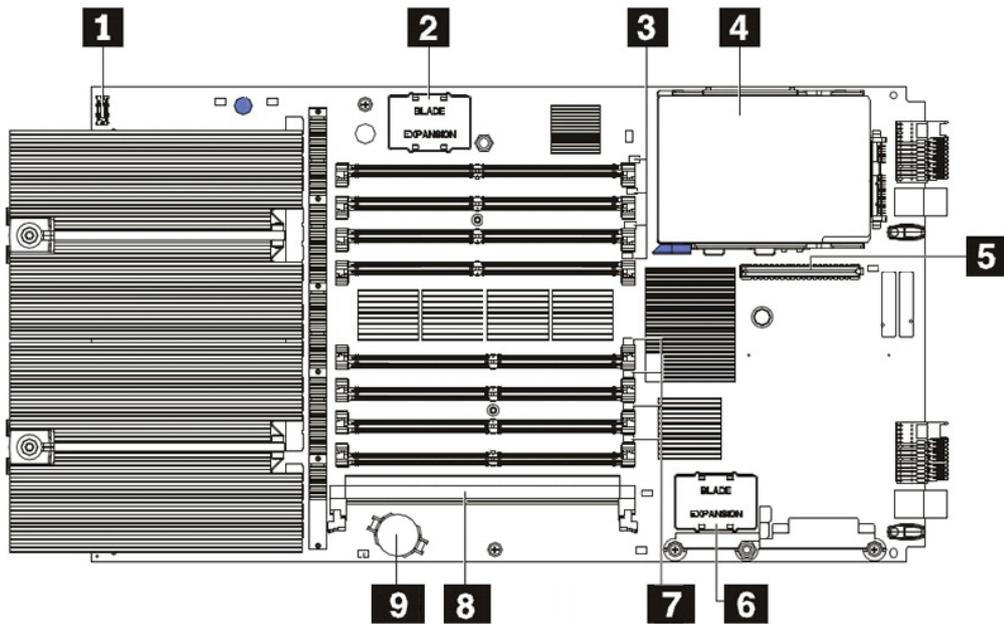

Figure 1-3. System-board connectors

Callout	Escala BL460 server connectors
1	Operator panel connector.
2	Expansion unit (SMP) connector.
3	DIMM 1-4 connectors (see Figure 1-5 for individual connectors).
4	SAS hard disk drive or SAS solid-state drive connector (Px-D1).
5	CFFv, or CIOv (1Xe) expansion card connector (Px-C12).
6	SFFh, or CFFh (PCIe) high-speed expansion card connector (Px-C11).
7	DIMM 5-8 connectors (see Figure 1-5 for individual connectors).
8	Management card connector (P1-C9).
9	3V lithium battery connector (P1-E1)

Table 1-2. Connectors description

Figure 1-4 shows individual DIMM connectors.

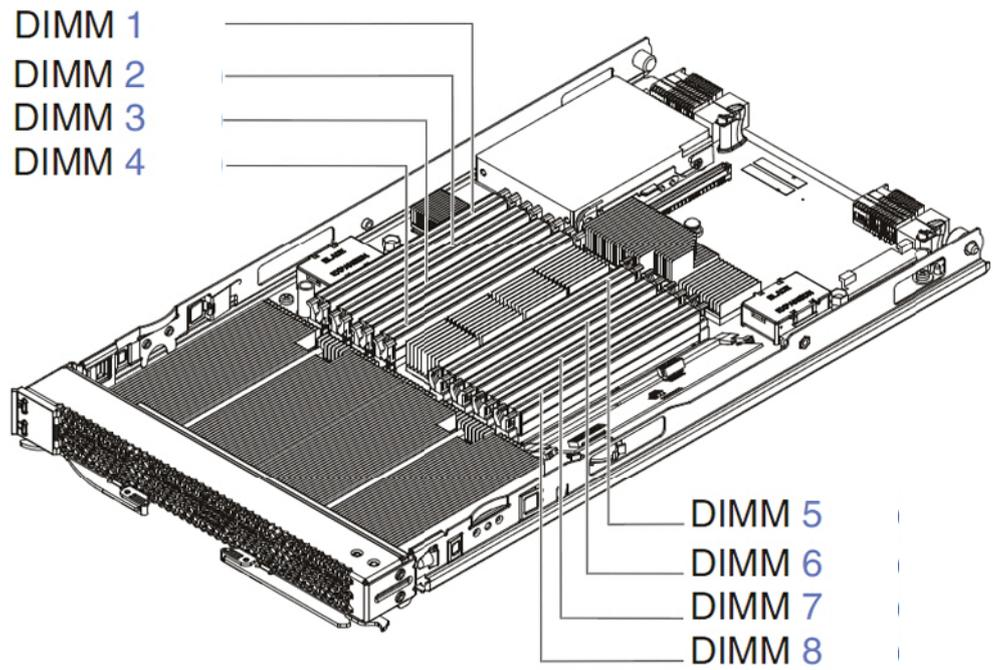

Figure 1-4. DIMM connectors

1.10 System-board LEDs

Use the illustration of the LEDs on the system board to identify a light emitting diode (LED).

Remove the blade server from the Bull Blade Chassis - Enterprise, open the cover to see any error LEDs that were turned on during error processing, and use the following figure to identify the failing component.

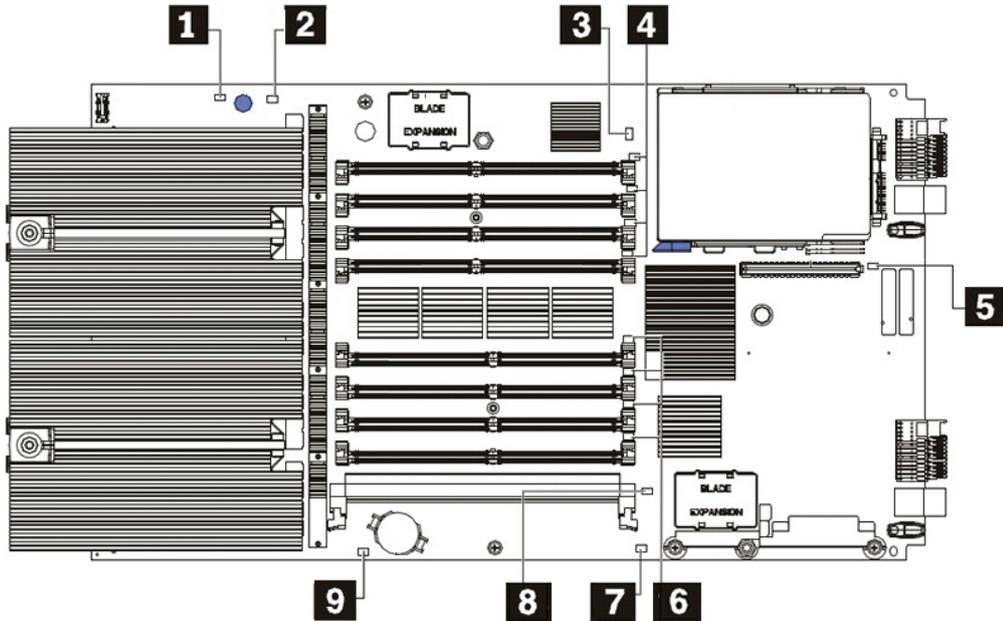

Figure 1-5. System-board LEDs

Callout	System-board LEDs
1	Light path power LED.
2	System board LED.
3	SAS hard disk drive LED.
4	DIMM 1-4 LEDs.
5	1Xe expansion card connector LED.
6	DIMM 5-8 LEDs.
7	PCIe high-speed expansion card LED.
8	Management card LED.
9	3V lithium battery LED.

Table 1-3. System-board LEDs locations

Chapter 2. Diagnostics

Use the available diagnostic tools to help solve any problems that might occur in the blade server.

The first and most crucial component of a solid serviceability strategy is the ability to accurately and effectively detect errors when they occur. While not all errors are a threat to system availability, those that go undetected are dangerous because the system does not have the opportunity to evaluate and act if necessary.

POWER6™ processor-based systems are specifically designed with error-detection mechanisms that extend from processor cores and memory to power supplies and hard drives.

POWER6™ processor-based systems contain specialized hardware detection circuitry for detecting erroneous hardware operations. Error checking hardware ranges from parity error detection coupled with processor instruction retry and bus retry, to ECC correction on caches and system buses.

Hardware error checkers have these distinct attributes:

- Continuous monitoring of system operations to detect potential calculation errors
- Attempted isolation of physical faults based on runtime detection of each unique failure
- Initiation of a wide variety of recovery mechanisms designed to correct a problem

POWER6™ processor-based systems include extensive hardware and firmware recovery logic.

Machine check handling

Machine checks are handled by firmware. When a machine check occurs, the firmware analyzes the error to identify the failing device and creates an error log entry.

If the system degrades to the point that the service processor cannot reach standby state, the ability to analyze the error does not exist. If the error occurs during POWER® hypervisor (PHYP) activities, the PHYP initiates a system reboot.

In partitioned mode, an error that occurs during partition activity is surfaced to the operating system in the partition.

What to do if you cannot solve a problem

If you cannot locate and correct the problem using the diagnostics tools and information, see [*Appendix A. Getting help and technical assistance.*](#)

2.1 Diagnostic tools

Tools are available to help you diagnose and solve hardware-related problems.

- **Power-on self-test (POST) progress codes (checkpoints), error codes, and isolation procedures**

The POST checks out the hardware at system initialization. IPL diagnostic functions test some system components and interconnections. The POST generates eight-digit checkpoints to mark the progress of powering up the blade server.

Use the management module to view progress codes.

The documentation of a progress code includes recovery actions for system hangs. See *"POST progress codes (checkpoints)"* on page 71 for more information.

If the service processor detects a problem during POST, an error code is logged in the management module event log. Error codes are also logged in the Linux® syslog or AIX® diagnostic log, if possible. See *"System reference codes (SRCs)"* on page 20.

The service processor can generate codes that point to specific isolation procedures. See *"Service processor problems"* on page 169.

- **Light path diagnostics**

Use the light path diagnostic LEDs on the system board to identify failing hardware. If the system error LED on the system LED panel on the front or rear of the Bull Blade Chassis - Enterprise is lit, one or more error LEDs on the Bull Blade Chassis - Enterprise components also might be lit.

Light path diagnostics help identify failing customer replaceable unit (CRUs). CRU location codes are included in error codes and the event log.

LED locations

See *"System-board LEDs"* on page 14.

Front panel

See *"Blade server control panel buttons and LEDs"* on page 7.

- **Troubleshooting tables**

Use the troubleshooting tables to find solutions to problems that have identifiable symptoms.

See *"Troubleshooting tables"* on page 158.

- **Dump data collection**

In some circumstances, an error might require a dump to show more data. The Integrated Virtual Manager (IVM) sets up a dump area. Specific IVM information is included as part of the information that can optionally be sent to Bull support for analysis.

See *"Collecting dump data"* on page 17 for more information.

- **Stand-alone diagnostics**

The AIX-based stand-alone *Diagnostics* CD is in the ship package. Boot the CD from a CD drive or from an AIX network installation manager (NIM) server if the blade server cannot boot to an operating system, no matter which operating system is installed.

Functions provided by the stand-alone diagnostics include:

- Analysis of errors reported by platform, such as microprocessor and memory
- Testing of resources, such as I/O adapters and devices
- Service aids, such as firmware update, format disk, and Raid Manager
- **Diagnostic utilities for the AIX operating system**

Run AIX concurrent diagnostics if AIX is functioning instead of the stand-alone diagnostics. Functions provided by disk-based AIX diagnostic include:

 - Automatic error log analysis
 - Analysis of errors reported by platform, such as microprocessor and memory
 - Testing of resources, such as I/O adapters and devices
 - Service aids, such as firmware update, format disk, and Raid Manager
- **Diagnostic utilities for Linux operating systems**

Linux on POWER® service and productivity tools include hardware diagnostic aids and productivity tools, and installation aids. The installation aids are provided in the Installation Toolkit for Linux on POWER®, a set of tools that aids the installation of Linux on servers with POWER® architecture. You can also use the tools to update the Escala BL460 blade server firmware.
- **Diagnostic utilities for other operating systems**

You can use the stand-alone *Diagnostics* CD to perform diagnostics on the Escala BL460 blade server, no matter which operating system is loaded on the blade server. However, other supported operating systems might have diagnostic tools that are available through the operating system. See the documentation for your operating system for more information.

2.2 Collecting dump data

A dump might be critical for fault isolation when the built-in First Failure Data Capture (FFDC) mechanisms are not capturing sufficient fault data. Even when a fault is identified, dump data can provide additional information that is useful in problem determination.

All hardware state information is part of the dump if a hardware checkstop occurs. When a checkstop occurs, the service processor attempts to dump data that is necessary to analyze the error from appropriate parts of the system.

Note If you power off the blade through the management module while the service processor is performing a dump, platform dump data is lost.

You might be asked to retrieve a dump to send it to Bull Support for analysis. The location of the dump data varies per operating system platform.

- Collect an AIX dump from the `/var/adm/platform` directory.
- Collect a Linux dump from the `/var/log/dump` directory.
- Collect an Integrated Virtualization Manager (IVM) dump from the IVM-managed Escala BL460 blade server through the **Manage Dumps** task in the IVM console.

2.3 Location codes

Location codes identify components of the blade server. Location codes are displayed with some error codes to identify the blade server component that is causing the error.

See “*System-board connectors*” on page 12 for component locations.

- Notes**
- Location codes do not indicate the location of the blade server within the Bull Blade Chassis - Enterprise. The codes identify components of the blade server only.
 - For checkpoints with no associated location code, see “*Light path diagnostics*” on page 182 to identify the failing component when there is a hang condition.
 - For checkpoints with location codes, use the following table to identify the failing component when there is a hang condition.
 - For 8-digit codes not listed in Table 1, see “*Checkout procedure*” on page 148.

Table 2-1. Location code

Location code	Component
Un location codes are for enclosure and VPD locations. Un = U ^{tttt} .mmm.ssssss tttt = system machine type mmm = system model number ssssss = system serial number	
Un-Px-C1	DIMM 1
Un-Px-C2	DIMM 2
Un-Px-C3	DIMM 3
Un-Px-C4	DIMM 4
Un-Px-C5	DIMM 5
Un-Px-C6	DIMM 6
Un-Px-C7	DIMM 7
Un-Px-C8	DIMM 8
Un-Px-C9	Management card
Un-Px-C11	PCIe high-speed expansion card
Un-Px-C12	CIOv high speed 1Xe expansion card
Un-Px-D1	SAS hard disk drive or SAS solid state drive
Un-P1-E1	Battery
Um codes are for firmware. The format is the same as for a Un location code. Um = U ^{tttt} .mmm.ssssss	
Um-Y1	Firmware version

2.4 Reference codes

Reference codes are diagnostic aids that help you determine the source of a hardware or operating system problem. To use reference codes effectively, use them in conjunction with other service and support procedures.

The Escala BL460 blade server produces several types of codes.

Progress codes: The power-on self-test (POST) generates eight-digit status codes that are known as *checkpoints* or *progress codes*, which are recorded in the management-module event log. The checkpoints indicate which blade server resource is initializing.

Error codes: The First Failure Data Capture (FFDC) error checkers capture fault data, which the baseboard management controller (BMC) service processor then analyzes. For unrecoverable errors (UEs), for recoverable events that meet or exceed their service thresholds, and for fatal system errors, an unrecoverable checkstop service event triggers the service processor to analyze the error, log the system reference code (SRC), and turn on the system attention LED.

The service processor logs the nine-word, eight-digit per word error code in the management-module event log. Error codes are either *system reference codes (SRCs)* or *service request numbers (SRNs)*. A location code might also be included.

Isolation procedures: If the fault analysis does not determine a definitive cause, the service processor might indicate a fault isolation procedure that you can use to isolate the failing component.

Viewing the codes

The Escala BL460 blade server does not display checkpoints or error codes on the remote console. The shared Bull Blade Chassis - Enterprise video also does not display the codes.

If the POST detects a problem, a 9-word, 8-digit error code is logged in the management-module event log. A location code that identifies a component might also be included. See *"Error logs"* on page 147 for information about viewing the management-module event log.

Service request numbers can be viewed using the AIX diagnostics CD, or various operating system utilities, such as AIX diagnostics or the Linux service aid *"diagela"*, if it is installed.

2.4.1 System reference codes (SRCs)

System reference codes indicate a server hardware or software problem that can originate in hardware, in firmware, or in the operating system.

A blade server component generates an error code when it detects a problem. An SRC identifies the component that generated the error code and describes the error.

Use the SRC information to identify a list of possibly failing items and to find information about any additional isolation procedures.

The following table shows the syntax of a nine-word B700xxxx SRC as it might be displayed in the event log of the management module.

The first word of the SRC in this example is the message identifier, **B7001111**. This example numbers each word after the first word to show relative word positions.

The seventh word is the direct select address, which is **77777777** in the example.

Table 2-2. Nine-word system reference code in the management-module event log

Index	Sev	Source	Date/Time	Text
1	E	Blade_05	01/21/2008, 17:15:14	(ESCALA BL460 -BC1BLD5E) SYS F/W: Error. Replace UNKNOWN (5008FECF B7001111 22222222 33333333 44444444 55555555 66666666 77777777 88888888 99999999)

Depending on your operating system and the utilities you have installed, error messages might also be stored in an operating system log. See the documentation that comes with the operating system for more information.

The management module can display the most recent 32 SRCs and time stamps. Manually refresh the list to update it.

Select **Blade Service Data** → *blade_name* in the management module to see a list of the 32 most recent SRCs.

Table 2-3. Management module reference code listing

Unique ID	System Reference Code	Timestamp
00040001	D1513901	2005-11-13 19:30:20
00000016	D1513801	2005-11-13 19:30:16

Any message with more detail is highlighted as a link in the System Reference Code column. Click the message to cause the management module to present the additional message detail:

```
D1513901
Created at: 2007-11-13 19:30:20
SRC Version: 0x02
Hex Words 2-5: 020110F0 52298910 C1472000 200000FF
```

SRC formats

SRCs are strings of either six or eight alphanumeric characters. The first four characters designate the reference code type and the second four characters designate the unit reference code (URC).

The first character indicates the type of error. In a few cases, the first two characters indicate the type of error:

- 1xxxxxx - System power control network (SPCN) error
- 6xxxxxx - Virtual optical device error
- A1xxxxxx - Attention required (Service processor)
- AAxxxxxx - Attention required (Partition firmware)
- B1xxxxxx - Service processor error, such as a boot problem
- B6xxxxxx – Licensed Internal Code or hardware event error
- B9xxxxxx – Software installation error
- BAxxxxxx - Partition firmware error
- Cxxxxxx - Checkpoint (must hang to indicate an error)
- Dxxxxxx - Dump checkpoint (must hang to indicate an error)

2.4.1.1 1xxxxxxx SRCs

The 1xxxxxxx system reference codes are system power control network (SPCN) reference codes.

Look for the rightmost 4 characters (yyyy in 1xxxxxxx) in the error code; this is the reference code. Find the reference code in Table 4.

Perform all actions before exchanging failing items.

Table 2-4. 1xxxxxxx SRCs

1xxxxxxx Error Codes	Description	Action
00AC	Informational message: AC loss was reported	No action is required.
00AD	Informational message: A service processor reset caused the blade server to power off	No action is required.
1F02	Informational message: The trace logs reached 1K of data.	No action is required.
2600	pGood master fault	<ol style="list-style-type: none"> 1. Go to "Checkout procedure" on page 148. 2. Replace the system-board and chassis assembly, as described in "Replacing the Tier 2 system-board and chassis assembly" on page 229.
2610	Power good (pGood) fault	<ol style="list-style-type: none"> 1. Go to "Checkout procedure" on page 148. 2. Replace the system-board and chassis assembly, as described in "Replacing the Tier 2 system-board and chassis assembly" on page 229.
2620	12V dc pGood input fault	<ol style="list-style-type: none"> 1. Go to "Checkout procedure" on page 148. 2. Replace the system-board and chassis assembly, as described in "Replacing the Tier 2 system-board and chassis assembly" on page 229.
2622	SMP expansion_comp_pgood fault	<ol style="list-style-type: none"> 1. Go to "Checkout procedure" on page 148. 2. Replace the system-board and chassis assembly, as described in "Replacing the Tier 2 system-board and chassis assembly" on page 229.
2625	PCIE_A0_PGOOD fault	<p>Perform the DTRCARD symbolic CRU isolation procedure by completing the following steps:</p> <ol style="list-style-type: none"> 1. Reseat the PCIe expansion card. 2. If the problem persists, replace the expansion card. 2. If the problem persists, go to "Checkout procedure" on page 148. 3. If the problem persists, replace the system-board and chassis assembly, as described in "Replacing the Tier 2 system-board and chassis assembly" on page 229. <p>The DTRCARD Symbolic CRU isolation procedure is in "Service processor problems", on page 169.</p>

- Follow the suggested actions in the order in which they are listed in the Action column until the problem is solved. If an action solves the problem, then you can stop performing the remaining actions.
- See Chapter 3, "Parts listing," on page 197 to determine which components are CRUs and which components are FRUs.

1xxxxxx Error Codes	Description	Action
2626	PCIE_A1_PGOOD fault	Perform the DTRCARD symbolic CRU isolation procedure by completing the following steps: <ol style="list-style-type: none"> 1. Reseat the PCIe expansion card. 2. If the problem persists, replace the expansion card. 2. If the problem persists, go to "Checkout procedure" on page 148. 3. If the problem persists, replace the system-board and chassis assembly, as described in "Replacing the Tier 2 system-board and chassis assembly" on page 229. The DTRCARD Symbolic CRU isolation procedure is in "Service processor problems", on page 169.
2627	PCIE_B_PGOOD fault	Perform the DTRCARD symbolic CRU isolation procedure by completing the following steps: <ol style="list-style-type: none"> 1. Reseat the PCIe expansion card. 2. If the problem persists, replace the expansion card. 2. If the problem persists, go to "Checkout procedure" on page 148. 3. If the problem persists, replace the system-board and chassis assembly, as described in "Replacing the Tier 2 system-board and chassis assembly" on page 229. The DTRCARD Symbolic CRU isolation procedure is in "Service processor problems", on page 169.
2629	1.5V reg_pgood fault	<ol style="list-style-type: none"> 1. Go to "Checkout procedure" on page 148. 2. Replace the system-board and chassis assembly, as described in "Replacing the Tier 2 system-board and chassis assembly" on page 229.
262B	1.8V reg_pgood fault	<ol style="list-style-type: none"> 1. Go to "Checkout procedure" on page 148. 2. Replace the system-board and chassis assembly, as described in "Replacing the Tier 2 system-board and chassis assembly" on page 229.
262C	5V reg_pgood fault	<ol style="list-style-type: none"> 1. Go to "Checkout procedure" on page 148. 2. Replace the system-board and chassis assembly, as described in "Replacing the Tier 2 system-board and chassis assembly" on page 229.
262D	3.3V reg_pgood fault	<ol style="list-style-type: none"> 1. Go to "Checkout procedure" on page 148. 2. Replace the system-board and chassis assembly, as described in "Replacing the Tier 2 system-board and chassis assembly" on page 229.
262E	2.5V reg_pgood fault	<ol style="list-style-type: none"> 1. Go to "Checkout procedure" on page 148. 2. Replace the system-board and chassis assembly, as described in "Replacing the Tier 2 system-board and chassis assembly" on page 229.
2630	VRM CPO core pGood fault	<ol style="list-style-type: none"> 1. Go to "Checkout procedure" on page 148. 2. Replace the system-board and chassis assembly, as described in "Replacing the Tier 2 system-board and chassis assembly" on page 229.
2632	VRM CPO cache pGood fault	<ol style="list-style-type: none"> 1. Go to "Checkout procedure" on page 148. 2. Replace the system-board and chassis assembly, as described in "Replacing the Tier 2 system-board and chassis assembly" on page 229.
2633	1.2V reg_pgood fault	<ol style="list-style-type: none"> 1. Go to "Checkout procedure" on page 148. 2. Replace the system-board and chassis assembly, as described in "Replacing the Tier 2 system-board and chassis assembly" on page 229.

- Follow the suggested actions in the order in which they are listed in the Action column until the problem is solved. If an action solves the problem, then you can stop performing the remaining actions.
- See Chapter 3, "Parts listing," on page 197 to determine which components are CRUs and which components are FRUs.

1xxxxxx Error Codes	Description	Action
2640	VRM CP1 core pGood fault	<ol style="list-style-type: none"> 1. Go to "Checkout procedure" on page 148. 2. Replace the system-board and chassis assembly, as described in "Replacing the Tier 2 system-board and chassis assembly" on page 229.
2642	VRM CP1 cache pGood fault	<ol style="list-style-type: none"> 1. Go to "Checkout procedure" on page 148. 2. Replace the system-board and chassis assembly, as described in "Replacing the Tier 2 system-board and chassis assembly" on page 229.
2647	No 12V dc coming to the blade server from the Bull Blade Chassis – Enterprise midplane	<ol style="list-style-type: none"> 1. Check the management-module event log for errors that indicate a power problem with the Bull Blade Chassis - Enterprise. 2. Resolve any problems that are found. 3. Reboot the blade server. 4. If the problem is not resolved, replace the system board and chassis assembly, as described in "Replacing the Tier 2 system-board and chassis assembly" on page 229.
2648	Blade power latch fault	<ol style="list-style-type: none"> 1. Go to "Checkout procedure" on page 148. 2. Replace the system-board and chassis assembly, as described in "Replacing the Tier 2 system-board and chassis assembly" on page 229.
2649	Blade power fault	<ol style="list-style-type: none"> 1. Go to "Checkout procedure" on page 148. 2. Replace the system-board and chassis assembly, as described in "Replacing the Tier 2 system-board and chassis assembly" on page 229.
2670	The Bull Blade Chassis - Enterprise encountered a problem, and the blade server was automatically shut down as a result	<ol style="list-style-type: none"> 1. Check the management-module event log for entries that were made around the time that the Escala BL460 blade server shut down. 2. Resolve any problems that are found. 3. Reboot the blade server. 4. If the problem is not resolved, replace the system board and chassis assembly, as described in "Replacing the Tier 2 system-board and chassis assembly" on page 229.
2671	12V power fault in the blade server	<ol style="list-style-type: none"> 1. Go to "Checkout procedure" on page 148. 2. Replace the system-board and chassis assembly, as described in "Replacing the Tier 2 system-board and chassis assembly" on page 229.
8400	Invalid configuration decode	<ol style="list-style-type: none"> 1. Check for server firmware updates. 2. Apply any available updates. 3. If the problem persists: <ol style="list-style-type: none"> a. Go to "Checkout procedure" on page 148. b. Replace the system-board and chassis assembly, as described in "Replacing the Tier 2 system-board and chassis assembly" on page 229.
8402	Unable to get VPD from the concentrator	<ol style="list-style-type: none"> 1. Go to "Checkout procedure" on page 148. 2. Replace the system-board and chassis assembly, as described in "Replacing the Tier 2 system-board and chassis assembly" on page 229.
8413	Invalid processor 1 VPD	<ol style="list-style-type: none"> 1. Go to "Checkout procedure" on page 148. 2. Replace the system-board and chassis assembly, as described in "Replacing the Tier 2 system-board and chassis assembly" on page 229.

- Follow the suggested actions in the order in which they are listed in the Action column until the problem is solved. If an action solves the problem, then you can stop performing the remaining actions.
- See *Chapter 3, "Parts listing,"* on page 197 to determine which components are CRUs and which components are FRUs.

1xxxxxx Error Codes	Description	Action
8414	Invalid processor 2 VPD	1. Go to " <i>Checkout procedure</i> " on page 148. 2. Replace the system-board and chassis assembly, as described in " <i>Replacing the Tier 2 system-board and chassis assembly</i> " on page 229.
8423	No processor VPD was found	1. Go to " <i>Checkout procedure</i> " on page 148. 2. Replace the system-board and chassis assembly, as described in " <i>Replacing the Tier 2 system-board and chassis assembly</i> " on page 229.
84A0	No backplane VPD was found	1. Go to " <i>Checkout procedure</i> " on page 148. 2. Replace the system-board and chassis assembly, as described in " <i>Replacing the Tier 2 system-board and chassis assembly</i> " on page 229.

2.4.1.2

6xxxxxxx SRCs

The 6xxxxxxx system reference codes are virtual optical reference codes.

Look for the rightmost 4 characters (yyyy in 6xxxxxxx) in the error code; this is the reference code. Find the reference code in *Table 2-5*.

Table 2-5. 6xxxxxxx SRCs

<ul style="list-style-type: none"> Follow the suggested actions in the order in which they are listed in the Action column until the problem is solved. If an action solves the problem, then you can stop performing the remaining actions. See <i>Chapter 3, "Parts listing,"</i> on page 197 to determine which components are CRUs and which components are FRUs. 		
6xxxxxxx Error Codes	Description	Action
632Byyyy codes are Network File System (NFS) virtual optical SRCs		
632BCFC1	A virtual optical device cannot access the file containing the list of volumes.	On this partition and on the Network File System server, verify that the proper file is specified and that the proper authority is granted.
632BCFC2	A non-recoverable error was detected while reading the list of volumes.	Resolve any errors on the Network File System server.
632BCFC3	The data in the list of volumes is not valid.	On the Network File System server, verify that the proper file is specified, that all files are entered correctly, that there are no blank lines, and that the character set used is valid.
632BCFC4	A virtual optical device cannot access the file containing the specified optical volume.	On the Network File System server, verify that the proper file is specified in the list of volumes, and that the proper authority is granted.
632BCFC5	A non-recoverable error was detected while reading a virtual optical volume.	Resolve any errors on the Network File System server.
632BCFC6	The file specified does not contain data that can be processed as a virtual optical volume.	On the Network File System server, verify that all the files specified in the list of optical volumes are correct.
632BCFC7	A virtual optical device detected an error reported by the Network File System server that cannot be recovered.	Resolve any errors on the Network File System server.
632BCFC8	A virtual optical device encountered a non-recoverable error.	Install any available operating system updates.
632Cyyyy codes are virtual optical SRCs		
632CC000	Informational system log entry only.	No corrective action is required.
632CC002	SCSI selection or reselection timeout occurred.	Refer to the hosting partition for problem analysis.
632CC010	Undefined sense key returned by device.	Refer to the hosting partition for problem analysis.
632CC020	Configuration error.	Refer to the hosting partition for problem analysis.
632CC100	SCSD bus error occurred.	Refer to the hosting partition for problem analysis.
632CC110	SCSD command timeout occurred.	Refer to the hosting partition for problem analysis.
632CC210	Informational system log entry only.	No corrective action is required.
632CC300	Media or device error occurred.	Refer to the hosting partition for problem analysis.
632CC301	Media or device error occurred.	Refer to the hosting partition for problem analysis.
632CC302	Media or device error occurred.	Refer to the hosting partition for problem analysis.
632CC303	Media has an unknown format.	No corrective action is required.

- Follow the suggested actions in the order in which they are listed in the Action column until the problem is solved. If an action solves the problem, then you can stop performing the remaining actions.
- See *Chapter 3, "Parts listing,"* on page 197 to determine which components are CRUs and which components are FRUs.

6xxxxxxx Error Codes	Description	Action
632CC333	Incompatible media.	<ol style="list-style-type: none"> 1. Verify that the disk has a supported format. 2. If the format is supported, clean the disk and attempt the failing operation again. 3. If the operation fails again with the same system reference code, ask your media source for a replacement disk.
632CC400	Physical link error detected by device.	Refer to the hosting partition for problem analysis.
632CC402	An internal program error occurred.	Install any available operating system updates.
632CCFF2	Informational system log entry only.	No corrective action is required.
632CCFF4	Internal device error occurred.	Refer to the hosting partition for problem analysis.
632CCFF6	Informational system log entry only.	No corrective action is required.
632CCFF7	Informational system log entry only.	No corrective action is required.
632CCFFE	Informational system log entry only.	No corrective action is required.
632CFF3D	Informational system log entry only.	No corrective action is required.
632CFF6D	Informational system log entry only.	No corrective action is required.

2.4.1.3 A1xxxxxx service processor SRCs

An A1xxxxxx system reference code (SRC) is an attention code that offers information about a platform or service processor dump or confirms a control panel function request.

Table 2-6. A1xxxxxx service processor SRCs

Attention code	Description	Action
A1xxxxxx	Attention code	<ol style="list-style-type: none"> 1. Go to "<i>Checkout procedure</i>" on page 148. 2. Replace the system board and chassis assembly, as described in "<i>Replacing the Tier 2 system-board and chassis assembly</i>" on page 229.

2.4.1.4 A200yyyy Logical partition SRCs

An A200yyyy SRC is a logical partition reference code that is deprecated in favor of a corresponding B2xx SRC. B2xx SRCs are described in "*B200xxxx Logical partition SRCs*" on page 31.

Table 2-7. A200yyyy Logical partition SRCs

Attention code	Description	Action
A200yyyy	See the description for the B200yyyy error code with the same yyyy value.	Perform the action described in the B200yyyy error code with the same yyyy value.

2.4.1.5 A700yyyy Licensed internal code SRCs

An A7xx SRC is a licensed internal code SRC that is deprecated in favor of a corresponding B7xx SRC. B7xx SRCs are described in “B700xxxx Licensed internal code SRCs” on page 38.

Table 2-8. A700yyyy Licensed internal code SRCs

Attention code	Description	Action
A7003000	A user-initiated platform dump occurred.	No service action required.
A700yyyy	See the description for the B700yyyy error code with the same yyyy value.	Perform the action in the B700yyyy error code with the same yyyy value.

2.4.1.6 AA00E1A8 to AA260005 Partition firmware attention codes

AAxx attention codes provide information about the next target state for the platform firmware. These codes might indicate that you need to perform an action.

Table 2-9 describes the partitioning firmware codes that may be displayed if POST detects a problem. Each message description includes a suggested action to correct the problem.

Table 2-9. AA00E1A8 to AA260005 Partition firmware attention codes

<ul style="list-style-type: none"> Follow the suggested actions in the order in which they are listed in the Action column until the problem is solved. If an action solves the problem, then you can stop performing the remaining actions. See Chapter 3, “Parts listing,” on page 197 to determine which components are CRUs and which components are FRUs. 		
Attention code	Description	Action
AA00E1A8	The system is booting to the open firmware prompt.	At the open firmware prompt, type dev /packages/gui obe and press Enter ; then, type 1 to select SMS Menu .
AA00E1A9	The system is booting to the System Management Services (SMS) menus.	<ol style="list-style-type: none"> If the system or partition returns to the SMS menus after a boot attempt failed, use the SMS menus to check the progress indicator history for a BAxx xxxx error, which may indicate why the boot attempt failed. Follow the actions for that error code to resolve the boot problem. Use the SMS menus to establish the boot list and restart the blade server.
AA00E1B0	Waiting for the user to select the language and keyboard. The menu should be visible on the console.	<ol style="list-style-type: none"> Check for server firmware updates. Apply any available updates. If the problem persists: <ol style="list-style-type: none"> Go to “Checkout procedure” on page 148. Replace the system-board and chassis assembly, as described in “Replacing the Tier 2 system-board and chassis assembly” on page 229.
AA00E1B1	Waiting for the user to accept or decline the license	<ol style="list-style-type: none"> Check for server firmware updates. Apply any available updates. If the problem persists: <ol style="list-style-type: none"> Go to “Checkout procedure” on page 148. Replace the system-board and chassis assembly, as described in “Replacing the Tier 2 system-board and chassis assembly” on page 229.

- Follow the suggested actions in the order in which they are listed in the Action column until the problem is solved. If an action solves the problem, then you can stop performing the remaining actions.
- See *Chapter 3, "Parts listing,"* on page 197 to determine which components are CRUs and which components are FRUs.

Attention code	Description	Action
AA060007	A keyboard was not found.	Verify that a keyboard is attached to the USB port that is assigned to the partition.
AA06000B	The system or partition was not able to find an operating system on any of the devices in the boot list.	<ol style="list-style-type: none"> 1. Use the SMS menus to modify the boot list so that it includes devices that have a known-good operating system and restart the blade server. 2. If the problem remains, go to "Boot problem resolution" on page 156.
AA06000C	The media in a device in the boot list was not bootable.	<ol style="list-style-type: none"> 1. Replace the media in the device with known-good media or modify the boot list to boot from another bootable device. 2. If the problem remains, go to "Boot problem resolution" on page 156.
AA06000D	The media in the device in the bootlist was not found under the I/O adapter specified by the bootlist.	<ol style="list-style-type: none"> 1. Verify that the media from which you are trying to boot is bootable or modify the boot list to boot from another bootable device. 2. If the problem remains, go to "Boot problem resolution" on page 156.
AA06000E	The adapter specified in the boot list is not present or is not functioning.	<ul style="list-style-type: none"> • For an AIX operating system: <ol style="list-style-type: none"> 1. Try booting the blade server from another bootable device; then, run AIX online diagnostics against the failing adapter. 2. If AIX cannot be booted from another device, boot the blade server using the stand-alone <i>Diagnostics</i> CD or a NIM server; then, run diagnostics against the failing adapter. • For a Linux operating system, boot the blade server using the stand-alone <i>Diagnostics</i> CD or a NIM server; then, run diagnostics against the failing adapter.
AA060011	The firmware did not find an operating system image and at least one hard disk in the boot list was not detected by the firmware. The firmware is retrying the entries in the boot list.	<p>This might occur if a disk enclosure that contains the boot disk is not fully initialized or if the boot disk belongs to another partition.</p> <p>Verify that:</p> <ul style="list-style-type: none"> • The boot disk belongs to the partition from which you are trying to boot. • The boot list in the SMS menus is correct.
AA130013	Bootable media is missing from a USB CD-ROM	Verify that a bootable CD is properly inserted in the CD or DVD drive and retry the boot operation.
AA130014	The media in a USB CD-ROM has changed.	<ol style="list-style-type: none"> 1. Retry the operation. 2. Check for server firmware updates; then, install the updates if available and retry the operation.
AA170210	Setenv/\$setenv parameter error - the name contains a null character.	<ol style="list-style-type: none"> 1. Go to "Checkout procedure" on page 148. 2. Replace the system-board and chassis assembly, as described in "Replacing the Tier 2 system-board and chassis assembly" on page 229.
AA170211	Setenv/\$setenv parameter error - the value contains a null character.	<ol style="list-style-type: none"> 1. Go to "Checkout procedure" on page 148. 2. Replace the system-board and chassis assembly, as described in "Replacing the Tier 2 system-board and chassis assembly" on page 229.
AA190001	The hypervisor function to get or set the time-of-day clock reported an error.	<ol style="list-style-type: none"> 1. Use the operating system to set the system clock. 2. If the problem persists, check for server firmware updates. 3. Install any available updates and retry the operation.
AA260001	Enter the Type Model Number (Must be 8 characters)	Enter the machine type and model of the blade server at the prompt.
AA260002	Enter the Serial Number (Must be 7 characters)	Enter the serial number of the blade server at the prompt.

- Follow the suggested actions in the order in which they are listed in the Action column until the problem is solved. If an action solves the problem, then you can stop performing the remaining actions.
- See Chapter 3, "Parts listing," on page 197 to determine which components are CRUs and which components are FRUs.

Attention code	Description	Action
AA260003	Enter System Unique ID (Must be 12 characters)	Enter the system unique ID number at the prompt.
AA260004	Enter WorldWide Port Number (Must be 12 characters)	Enter the worldwide port number of the blade server at the prompt.
AA260005	Enter Brand (Must be 2 characters)	Enter the brand number of the blade server at the prompt.

2.4.1.7 Bxxxxxx Service processor early termination SRCs

A B181xxxx system reference code (SRC) is an error code that is related to an event or exception that occurred in the service processor firmware.

Table 2-10 describes error codes that might occur if POST detects a problem. The description also includes suggested actions to correct the problem.

Note For problems persisting after completing the suggested actions, see "Solving undetermined problems" on page 194.

Table 2-10. B181xxxx Service processor early termination SRCs

B181 xxxx Error Codes	Description	Action
7200	Invalid boot request	Go to "Checkout procedure" on page 148.
7201	Service processor failure	
7202	The permanent and temporary firmware sides are both marked invalid	
7203	Error setting boot parameters	
7204	Error reading boot parameters	
7205	Boot code error	
7206	Unit check timer was reset	
7207	Error reading from NVRAM	
7208	Error writing to NVRAM	
7209	The service processor boot watchdog timer expired and forced the service processor to attempt a boot from the other firmware image in the service processor flash memory	
720A	Power-off reset occurred. FipsDump should be analyzed: Possible software problem	

2.4.1.8 B200xxxx Logical partition SRCs

A B200xxxx system reference code (SRC) is an error code that is related to logical partitioning.

Table 2-11 describes error codes that might be displayed if POST detects a problem. The description also includes suggested actions to correct the problem.

Note For problems persisting after completing the suggested actions, see “Checkout procedure” on page 148 and “Solving undetermined problems” on page 194.

Table 2-11. B200xxxx Logical partition SRCs

B200 xxxx Error codes	Description	Action
1130	A problem occurred during the migration of a partition You attempted to migrate a partition to a system that has a power or thermal problem. The migration will not continue.	Look for and fix power or thermal problems and then retry the migration.
1131	A problem occurred during the migration of a partition. The migration of a partition did not complete.	Check for server firmware updates; then, install the updates if available.
1132	A problem occurred during the startup of a partition. A platform firmware error occurred while it was trying to allocate memory. The startup will not continue.	Collect a platform dump and then go to “Firmware problem isolation” on page 185.
1133	A problem occurred during the migration of a partition. The migration of a partition did not complete.	Check for server firmware updates; then, install the updates if available.
1134	A problem occurred during the migration of a partition. The migration of a partition did not complete.	Check for server firmware updates; then, install the updates if available.
1140	A problem occurred during the migration of a partition. The migration of a partition did not complete.	Check for server firmware updates; then, install the updates if available.
1141	A problem occurred during the migration of a partition. The migration of a partition did not complete.	Check for server firmware updates; then, install the updates if available.
1142	A problem occurred during the migration of a partition. The migration of a partition did not complete.	Check for server firmware updates; then, install the updates if available.

- Follow the suggested actions in the order in which they are listed in the Action column until the problem is solved. If an action solves the problem, then you can stop performing the remaining actions.
- See Chapter 3, “Parts listing,” on page 197 to determine which components are CRUs and which components are FRUs.

- Follow the suggested actions in the order in which they are listed in the Action column until the problem is solved. If an action solves the problem, then you can stop performing the remaining actions.
- See *Chapter 3, "Parts listing,"* on page 197 to determine which components are CRUs and which components are FRUs.

B200 xxxx Error codes	Description	Action
1143	A problem occurred during the migration of a partition. The migration of a partition did not complete.	Check for server firmware updates; then, install the updates if available.
1144	A problem occurred during the migration of a partition. The migration of a partition did not complete.	Check for server firmware updates; then, install the updates if available.
1148	A problem occurred during the migration of a partition. The migration of a partition did not complete.	Check for server firmware updates; then, install the updates if available.
1150	During the startup of a partition, a partitioning configuration problem occurred.	Go to <i>"Verifying the partition configuration"</i> on page 152.
1151	A problem occurred during the migration of a partition. The migration of a partition did not complete.	Check for server firmware updates; then, install the updates if available.
1170	During the startup of a partition, a failure occurred due to a validation error.	Go to <i>"Verifying the partition configuration"</i> on page 152.
1225	A problem occurred during the startup of a partition. The partition attempted to start up prior to the platform fully initializing. Restart the partition after the platform has fully completed and the platform is not in standby mode.	Restart the partition.
1230	During the startup of a partition, a partitioning configuration problem occurred; the partition is lacking the necessary resources to start up.	Go to <i>"Verifying the partition configuration"</i> on page 152.
1260	A problem occurred during the startup of a partition. The partition could not start at the Timed Power On setting because the partition was not set to Normal.	Set the partition to Normal.
1265	The partition could not start up. An operating system Main Storage Dump startup was attempted with the startup side on D-mode, which is not a valid operating system startup scenario. The startup will be halted. This SRC can occur when a D-mode SLIC installation fails and attempts a Main Storage Dump.	Correct the startup settings.
1266	The partition could not start up. You are attempting to start up an operating system that is not supported.	Install a supported operating system and restart the partition.
1280	A problem occurred during a partition Main Storage Dump. A mainstore dump startup did not complete due to a configuration mismatch.	Go to <i>"Firmware problem isolation"</i> on page 185.
1281	A partition memory error occurred. The failed memory will no longer be used.	Restart the partition.

- Follow the suggested actions in the order in which they are listed in the Action column until the problem is solved. If an action solves the problem, then you can stop performing the remaining actions.
- See *Chapter 3, "Parts listing,"* on page 197 to determine which components are CRUs and which components are FRUs.

B200 xxxx Error codes	Description	Action
1282	A problem occurred during the startup of a partition.	Go to <i>"Firmware problem isolation"</i> on page 185.
1320	A problem occurred during the startup of a partition. No default load source was selected. The startup will attempt to continue, but there may not be enough information to find the correct load source.	Configure a load source for the partition. Then restart the partition.
1321	A problem occurred during the startup of a partition.	Verify that the correct slot is specified for the load source. Then restart the partition.
1322	In the partition startup, code failed during a check of the load source path.	Verify that the path for the load source is specified correctly. Then restart the partition.
2048	A problem occurred during a partition Main Storage Dump. A mainstore dump startup did not complete due to a copy error.	Go to <i>"Firmware problem isolation"</i> on page 185.
2054	A problem occurred during a partition Main Storage Dump. A mainstore dump startup did not complete due to a configuration mismatch.	Go to <i>"Firmware problem isolation"</i> on page 185.
2058	A problem occurred during a partition Main Storage Dump. A mainstore dump startup did not complete due to a copy error.	Go to <i>"Firmware problem isolation"</i> on page 185.
2210	Informational system log entry only.	No corrective action is required.
2220	Informational system log entry only.	No corrective action is required.
2250	During the startup of a partition, an attempt to toggle the power state of a slot has failed.	Check for server firmware updates; then, install the updates if available.
2260	During the startup of a partition, the partition firmware attempted an operation that failed.	Go to <i>"Firmware problem isolation"</i> on page 185.
2300	During the startup of a partition, an attempt to toggle the power state of a slot has failed.	Check for server firmware updates; then, install the updates if available.
2310	During the startup of a partition, the partition firmware attempted an operation that failed.	Go to <i>"Firmware problem isolation"</i> on page 185.
2320	During the startup of a partition, the partition firmware attempted an operation that failed.	Go to <i>"Firmware problem isolation"</i> on page 185.
2425	During the startup of a partition, the partition firmware attempted an operation that failed.	Go to <i>"Firmware problem isolation"</i> on page 185.
2426	During the startup of a partition, the partition firmware attempted an operation that failed.	Go to <i>"Firmware problem isolation"</i> on page 185.
2475	During the startup of a partition, a slot that was needed for the partition was either empty or the device in the slot has failed.	Check for server firmware updates; then, install the updates if available.
2485	During the startup of a partition, the partition firmware attempted an operation that failed.	Go to <i>"Firmware problem isolation"</i> on page 185.
3000	Informational system log entry only.	No corrective action is required.

- Follow the suggested actions in the order in which they are listed in the Action column until the problem is solved. If an action solves the problem, then you can stop performing the remaining actions.
- See *Chapter 3, "Parts listing,"* on page 197 to determine which components are CRUs and which components are FRUs.

B200 xxxx Error codes	Description	Action
3081	During the startup of a partition, the startup did not complete due to a copy error.	Check for server firmware updates; then, install the updates if available.
3084	A problem occurred during the startup of a partition. The adapter type might not be supported.	Verify that the adapter type is supported.
3088	Informational system log entry only.	No corrective action is required.
308C	A problem occurred during the startup of a partition. The adapter type cannot be determined.	Verify that a valid I/O Load Source is tagged.
3090	A problem occurred during the startup of a partition.	Go to <i>"Firmware problem isolation"</i> on page 185.
3110	A problem occurred during the startup of a partition.	Go to <i>"Firmware problem isolation"</i> on page 185.
3113	A problem occurred during the startup of a partition.	Look for B7xx xxxx errors and resolve them.
3114	A problem occurred during the startup of a partition.	Look for other errors and resolve them.
3120	Informational system log entry only.	No corrective action is required.
3123	Informational system log entry only.	No corrective action is required.
3125	During the startup of a partition, the blade server firmware could not obtain a segment of main storage within the blade server to use for managing the creation of a partition.	Check for server firmware updates; then, install the updates if available.
3128	A problem occurred during the startup of a partition. A return code for an unexpected failure was returned when attempting to query the load source path.	Look for and resolve B700 69xx errors.
3130	A problem occurred during the startup of a partition.	Check for server firmware updates; then, install the updates if available.
3135	A problem occurred during the startup of a partition.	Check for server firmware updates; then, install the updates if available.
3140	A problem occurred during the startup of a partition. This is a configuration problem in the partition.	Reconfigure the partition to include the intended load source path.
3141	Informational system log entry only.	No corrective action is required.
3142	Informational system log entry only.	No corrective action is required.
3143	Informational system log entry only.	No corrective action is required.
3144	Informational system log entry only.	No corrective action is required.
3145	Informational system log entry only.	No corrective action is required.
3200	Informational system log entry only.	No corrective action is required.
4158	Informational system log entry only.	No corrective action is required.
4400	A problem occurred during the startup of a partition.	Check for server firmware updates; then, install the updates if available.
5106	A problem occurred during the startup of a partition. There is not enough space to contain the partition main storage dump. The startup will not continue.	Verify that there is sufficient memory available to start the partition as it is configured. If there is already enough memory, then go to <i>"Firmware problem isolation"</i> on page 185.
5109	A problem occurred during the startup of a partition. There was a partition main storage dump problem. The startup will not continue.	Go to <i>"Firmware problem isolation"</i> on page 185.

- Follow the suggested actions in the order in which they are listed in the Action column until the problem is solved. If an action solves the problem, then you can stop performing the remaining actions.
- See *Chapter 3, "Parts listing,"* on page 197 to determine which components are CRUs and which components are FRUs.

B200 xxxx Error codes	Description	Action
5114	A problem occurred during the startup of a partition. There is not enough space to contain the partition main storage dump. The startup will not continue.	Go to "Firmware problem isolation" on page 185.
5115	A problem occurred during the startup of a partition. There was an error reading the partition main storage dump from the partition load source into main storage. The startup will attempt to continue.	If the startup does not continue, look for and resolve other errors.
5117	A problem occurred during the startup of a partition. A partition main storage dump has occurred but cannot be written to the load source device because a valid dump already exists.	Use the Main Storage Dump Manager to rename or copy the current main storage dump.
5121	A problem occurred during the startup of a partition. There was an error writing the partition main storage dump to the partition load source. The startup will not continue.	Look for related errors in the □Product Activity Log□ and fix any problems found. Use virtual control panel function 34 to retry the current Main Store Dump startup while the partition is still in the failed state.
5122	Informational system log entry only.	No corrective action is required.
5123	Informational system log entry only.	No corrective action is required.
5135	A problem occurred during the startup of a partition. There was an error writing the partition main storage dump to the partition load source. The main store dump startup will continue.	Look for other errors and resolve them.
5137	A problem occurred during the startup of a partition. There was an error writing the partition main storage dump to the partition load source. The main store dump startup will continue.	Look for other errors and resolve them.
5145	A problem occurred during the startup of a partition. There was an error writing the partition main storage dump to the partition load source. The main store dump startup will continue.	Look for other errors and resolve them.
5148	A problem occurred during the startup of a partition. An error occurred while doing a main storage dump that would have caused another main storage dump. The startup will not continue.	Go to "Firmware problem isolation" on page 185.
5149	A problem occurred during the startup of a partition while doing a Firmware Assisted Dump that would have caused another Firmware Assisted Dump.	Check for server firmware updates; then, install the updates if available.
514A	A Firmware Assisted Dump did not complete due to a copy error.	Check for server firmware updates; then, install the updates if available.
542A	A Firmware Assisted Dump did not complete due to a read error.	Check for server firmware updates; then, install the updates if available.
542B	A Firmware Assisted Dump did not complete due to a copy error.	Check for server firmware updates; then, install the updates if available.
543A	A Firmware Assisted Dump did not complete due to a copy error.	Check for server firmware updates; then, install the updates if available.
543B	A Firmware Assisted Dump did not complete due to a copy error.	Check for server firmware updates; then, install the updates if available.
543C	Informational system log entry only.	No corrective action is required.

- Follow the suggested actions in the order in which they are listed in the Action column until the problem is solved. If an action solves the problem, then you can stop performing the remaining actions.
- See Chapter 3, "Parts listing," on page 197 to determine which components are CRUs and which components are FRUs.

B200 xxxx Error codes	Description	Action
543D	A Firmware Assisted Dump did not complete due to a copy error.	Check for server firmware updates; then, install the updates if available.
6006	During the startup of a partition, a system firmware error occurred when the partition memory was being initialized; the startup will not continue.	Go to "Firmware problem isolation" on page 185.
6012	During the startup of a partition, the partition LID failed to completely load into the partition main storage area.	Go to "Firmware problem isolation" on page 185.
6015	A problem occurred during the startup of a partition. The load source media is corrupted or not valid.	Replace the load source media.
6025	A problem occurred during the startup of a partition. This is a problem with the load source media being corrupt or not valid.	Replace the load source media.
6027	During the startup of a partition, a failure occurred when allocating memory for an internal object used for firmware module load operations.	<ol style="list-style-type: none"> 1. Make sure that enough main storage was allocated to the partition. 2. Retry the operation.
6110	A problem occurred during the startup of a partition. There was an error on the load source device. The startup will attempt to continue.	Look for other errors and resolve them.
690A	During the startup of a partition, an error occurred while copying open firmware into the partition load area.	Go to "Firmware problem isolation" on page 185.
7200	Informational system log entry only.	No corrective action is required.
8080	Informational system log entry only.	No corrective action is required.
8081	During the startup of a partition, an internal firmware time-out occurred; the partition might continue to start up but it can experience problems while running.	Check for server firmware updates; then, install the updates if available.
8105	During the startup of a partition, there was a failure loading the VPD areas of the partition; the load source media has been corrupted or is unsupported on this server.	Check for server firmware updates; then, install the updates if available.
8106	A problem occurred during the startup of a partition. The startup will not continue.	Replace the load source media.
8107	During the startup of a partition, there was a problem getting a segment of main storage in the blade server main storage.	Check for server firmware updates; then, install the updates if available.
8109	During the startup of a partition, a failure occurred. The startup will not continue.	<ol style="list-style-type: none"> 1. Make sure that there is enough memory to start up the partition. 2. Check for server firmware updates; then, install the updates if available.
8111	A problem occurred during the startup of a partition.	Check for server firmware updates; then, install the updates if available.
8112	During the startup of a partition, a failure occurred; the startup will not continue.	Check for server firmware updates; then, install the updates if available.
8113	During the startup of a partition, an error occurred while mapping memory for the partition startup.	Check for server firmware updates; then, install the updates if available.

- Follow the suggested actions in the order in which they are listed in the Action column until the problem is solved. If an action solves the problem, then you can stop performing the remaining actions.
- See *Chapter 3, "Parts listing,"* on page 197 to determine which components are CRUs and which components are FRUs.

B200 xxxx Error codes	Description	Action
8114	During the startup of a partition, there was a failure verifying the VPD for the partition resources during startup.	Check for server firmware updates; then, install the updates if available.
8115	During the startup of a partition, there was a low level partition-to-partition communication failure.	Check for server firmware updates; then, install the updates if available.
8117	During the startup of a partition, the partition did not start up due to a system firmware error.	Check for server firmware updates; then, install the updates if available.
8121	During the startup of a partition, the partition did not start up due to a system firmware error.	Go to "Firmware problem isolation" on page 185.
8123	During the startup of a partition, the partition did not start up due to a system firmware error.	Go to "Firmware problem isolation" on page 185.
8125	During the startup of a partition, the partition did not start up due to a system firmware error.	Go to "Firmware problem isolation" on page 185.
8127	During the startup of a partition, the partition did not start up due to a system firmware error.	Go to "Firmware problem isolation" on page 185.
8129	During the startup of a partition, the partition did not start up due to a system firmware error.	Go to "Firmware problem isolation" on page 185.
813A	There was a problem establishing a console.	Go to "Firmware problem isolation" on page 185.
8140	Informational system log entry only.	No corrective action is required.
8141	Informational system log entry only.	No corrective action is required.
8142	Informational system log entry only.	No corrective action is required.
8143	Informational system log entry only.	No corrective action is required.
8144	Informational system log entry only.	No corrective action is required.
8145	Informational system log entry only.	No corrective action is required.
8150	System firmware detected an error.	Collect a platform dump and then go to "Firmware problem isolation" on page 185.
8151	System firmware detected an error.	Use the Integrated Virtual Manager (IVM) to increase the Logical Memory Block (LMB) size, and to reduce the number of virtual devices for the partition.
8152	No active system processors.	Verify that processor resources are assigned to the partition.
8160	A problem occurred during the migration of a partition.	Contact Bull support, as described in Appendix A, "Getting Help and Technical Assistance", on page 239.
8161	A problem occurred during the migration of a partition.	Contact Bull support, as described in Appendix A, "Getting Help and Technical Assistance", on page 239.
A100	A partition ended abnormally; the partition could not stay running and shut itself down.	1. Check the error logs and take the actions for the error codes that are found. 2. Go to "Firmware problem isolation" on page 185.
A101	A partition ended abnormally; the partition could not stay running and shut itself down.	1. Check the error logs and take the actions for the error codes that are found. 2. Go to "Firmware problem isolation" on page 185.
A140	A lower priority partition lost a usable processor to supply it to a higher priority partition with a bad processor.	Evaluate the entire LPAR configuration. Adjust partition profiles with the new number of processors available in the system.
B07B	Informational system log entry only.	No corrective action is required.

- Follow the suggested actions in the order in which they are listed in the Action column until the problem is solved. If an action solves the problem, then you can stop performing the remaining actions.
- See *Chapter 3, "Parts listing,"* on page 197 to determine which components are CRUs and which components are FRUs.

B200 xxxx Error codes	Description	Action
B215	A problem occurred after a partition ended abnormally. There was a communications problem between this partition's service processor and the platform's service processor.	Restart the platform.
C1F0	An internal system firmware error occurred during a partition shutdown or a restart.	Go to "Firmware problem isolation" on page 185.
D150	A partition ended abnormally; there was a communications problem between this partition and the code that handles resource allocation.	Check for server firmware updates; then, install the updates if available.
E0AA	A problem occurred during the power off of a partition.	Go to "Firmware problem isolation" on page 185.
F001	A problem occurred during the startup of a partition. An operation has timed out.	Look for other errors and resolve them.
F003	During the startup of a partition, the partition processor(s) did not start the firmware within the time-out window.	Collect the partition dump information; then, go to "Firmware problem isolation" on page 185.
F004	Informational system log entry only.	No corrective action is required.
F005	Informational system log entry only.	No corrective action is required.
F006	During the startup of a partition, the code load operation for the partition startup timed out.	1. Check the error logs and take the actions for the error codes that are found. 2. Go to "Firmware problem isolation" on page 185.
F007	During a shutdown of the partition, a time-out occurred while trying to stop a partition.	Check for server firmware updates; then, install the updates if available.
F008	Informational system log entry only.	No corrective action is required.
F009	Informational system log entry only.	No corrective action is required.
F00A	Informational system log entry only.	No corrective action is required.
F00B	Informational system log entry only.	No corrective action is required.
F00C	Informational system log entry only.	No corrective action is required.
F00D	Informational system log entry only.	No corrective action is required.

2.4.1.9 B700xxxx Licensed internal code SRCs

A B700xxxx system reference code (SRC) is an error code that is related to licensed internal code.

Table 2-12 describes the error codes that may be displayed if POST detects a problem. Suggested actions to correct the problem are also described.

Note For problems persisting after completing the suggested actions, see "Checkout procedure" on page 148 and "Solving undetermined problems" on page 194.

Table 2-12. B700xxxx Licensed internal code SRCs

<p>Follow the suggested actions in the order in which they are listed in the Action column until the problem is solved. If an action solves the problem, then you can stop performing the remaining actions.</p> <p>See <i>Chapter 3, "Parts listing,"</i> on page 197 to determine which components are CRUs and which components are FRUs.</p>		
B700 xxxx Error codes	Description	Action
0102	System firmware detected an error. A machine check occurred during startup.	<ol style="list-style-type: none"> 1. Collect the event log information. 2. Go to "Firmware problem isolation" on page 185.
0103	System firmware detected a failure	<ol style="list-style-type: none"> 1. Collect the event log information. 2. Collect the platform dump information. 3. Go to "Firmware problem isolation" on page 185.
0104	System firmware failure. Machine check, undefined error occurred.	<ol style="list-style-type: none"> 1. Check for server firmware updates. 2. Update the firmware.
0105	System firmware detected an error. More than one request to terminate the system was issued.	Go to "Firmware problem isolation" on page 185.
0106	System firmware failure.	<ol style="list-style-type: none"> 1. Collect the event log information. 2. Collect the platform dump information. 3. Go to "Firmware problem isolation" on page 185.
0107	System firmware failure. The system detected an unrecoverable machine check condition.	<ol style="list-style-type: none"> 1. Collect the event log information. 2. Collect the platform dump information. 3. Go to "Firmware problem isolation" on page 185.
0200	System firmware has experienced a low storage condition	<p>No immediate action is necessary.</p> <p>Continue running the system normally. At the earliest convenient time or service window, work with Bull Support to collect a platform dump and restart the system; then, go to "Firmware problem isolation" on page 185.</p>
0201	System firmware detected an error	<p>No immediate action is necessary.</p> <p>Continue running the system normally. At the earliest convenient time or service window, work with Bull Support to collect a platform dump and restart the system; then, go to "Firmware problem isolation" on page 185.</p>
0302	System firmware failure	<ol style="list-style-type: none"> 1. Collect the platform dump information. 2. Go to "Firmware problem isolation" on page 185.
0441	Service processor failure. The platform encountered an error early in the startup or termination process.	Replace the system-board and chassis assembly, as described in "Replacing the Tier 2 system-board and chassis assembly" on page 229.
0443	Service processor failure.	Replace the system-board and chassis assembly, as described in "Replacing the Tier 2 system-board and chassis assembly" on page 229.
0601	Informational system log entry only.	<p>No corrective action is required.</p> <p>Note: This code and associated data can be used to determine why the time of day for a partition was lost.</p>
0602	System firmware detected an error condition.	<ol style="list-style-type: none"> 1. Collect the event log information. 2. Go to "Firmware problem isolation" on page 185.
0611	There is a problem with the system hardware clock; the clock time is invalid.	Use the operating system to set the system clock.
0621	Informational system log entry only.	No corrective action is required.
0641	System firmware detected an error.	<ol style="list-style-type: none"> 1. Collect the platform dump information. 2. Go to "Firmware problem isolation" on page 185.

Follow the suggested actions in the order in which they are listed in the Action column until the problem is solved. If an action solves the problem, then you can stop performing the remaining actions.

See Chapter 3, "Parts listing," on page 197 to determine which components are CRUs and which components are FRUs.

B700 xxxx Error codes	Description	Action
0650	System firmware detected an error. Resource management was unable to allocate main storage. A platform dump was initiated.	1. Collect the event log. 2. Collect the platform dump data. 3. Collect the partition configuration information. 4. Go to "Firmware problem isolation" on page 185.
0651	The system detected an error in the system clock hardware	Replace the system-board and chassis assembly, as described in "Replacing the Tier 2 system-board and chassis assembly" on page 229.
0803	Informational system log entry only.	No corrective action is required.
0804	Informational system log entry only.	No corrective action is required.
0A00	Informational system log entry only.	No corrective action is required.
0A01	Informational system log entry only.	No corrective action is required.
0A10	Informational system log entry only.	No corrective action is required.
1150	Informational system log entry only.	No corrective action is required.
1151	Informational system log entry only.	No corrective action is required.
1152	Informational system log entry only.	No corrective action is required.
1160	Service processor failure	1. Go to "Firmware problem isolation" on page 185. 2. Replace the system-board and chassis assembly, as described in "Replacing the Tier 2 system-board and chassis assembly" on page 229.
1161	Informational system log entry only.	No corrective action is required.
1730	The VPD for the system is not what was expected at startup.	Replace the management card, as described in "Removing the management card" on page 216 and "Installing the management card" on page 217.
1731	The VPD on a memory DIMM is not correct and the memory on the DIMM cannot be used, resulting in reduced memory.	Replace the MEMDIMM symbolic CRU, as described in "Service processor problems" on page 198.
1732	The VPD on a processor card is not correct and the processor card cannot be used, resulting in reduced processing power.	Replace the system-board and chassis assembly, as described in "Replacing the Tier 2 system-board and chassis assembly" on page 229.
1733	System firmware failure. The startup will not continue.	Look for and correct B1xxxxxx errors. If there are no serviceable B1xxxxxx errors, or if correcting the errors does not correct the problem, contact Bull support to reset the server firmware settings. Attention: Resetting the server firmware settings results in the loss of all of the partition data that is stored on the service processor. Before continuing with this operation, manually record all settings that you intend to preserve. The service processor reboots after Bull Support resets the server firmware settings. If the problem persists, Replace the system-board and chassis assembly, as described in "Replacing the Tier 2 system-board and chassis assembly" on page 229.

Follow the suggested actions in the order in which they are listed in the Action column until the problem is solved. If an action solves the problem, then you can stop performing the remaining actions.

See Chapter 3, "Parts listing," on page 197 to determine which components are CRUs and which components are FRUs.

B700 xxxx Error codes	Description	Action
173A	A VPD collection overflow occurred.	1. Look for and resolve other errors. 2. If there are no other errors: <ol style="list-style-type: none"> Update the firmware to the current level, as described in "Updating the firmware" on page 231. You might also have to update the management module firmware to a compatible level.
173B	A system firmware failure occurred during VPD collection.	Look for and correct other B1xxxxxx errors.
4091	Informational system log entry only.	No corrective action is required.
4400	There is a platform dump to collect	1. Collect the platform dump information. 2. Go to "Firmware problem isolation" on page 185.
4401	System firmware failure. The system firmware detected an internal problem.	Go to "Firmware problem isolation" on page 185.
4402	A system firmware error occurred while attempting to allocate the memory necessary to create a platform dump.	Go to "Firmware problem isolation" on page 185.
4705	System firmware failure. A problem occurred when initializing, reading, or using the system VPD. The Capacity on Demand function is not available.	Restart the system.
4710	Informational system log entry only.	No corrective action is required.
4714	Informational system log entry only.	No corrective action is required.
4788	Informational system log entry only.	No corrective action is required.
5120	System firmware detected an error	If the system is not exhibiting problematic behavior, you can ignore this error. Otherwise, go to "Firmware problem isolation" on page 185.
5121	System firmware detected a programming problem for which a platform dump may have been initiated.	1. Collect the event log information. 2. Collect the platform dump information. 3. Go to "Firmware problem isolation" on page 185.
5122	An error occurred during a search for the load source.	If the partition fails to startup, go to "Firmware problem isolation" on page 185. Otherwise, no corrective action is required.
5123	Informational system log entry only.	No corrective action is required.
5190	Operating system error. The server firmware detected a problem in an operating system.	Check for error codes in the partition that is reporting the error and take the appropriate actions for those error codes.
5191	System firmware detected a virtual I/O configuration error.	1. Use the Integrated Virtual Manager (IVM) to verify or reconfigure the invalid virtual I/O configuration. 2. Check for server firmware updates; then, install the updates if available.
5209	Informational system log entry only.	No corrective action is required.
5219	Informational system log entry only.	No corrective action is required.
5300	System firmware detected a failure while partitioning resources. The platform partitioning code encountered an error.	Check the management-module event log for error codes; then, take the actions associated with those error codes.
5301	User intervention required. The system detected a problem with the partition configuration.	Use the Integrated Virtual Manager (IVM) to reallocate the system resources.

Follow the suggested actions in the order in which they are listed in the Action column until the problem is solved. If an action solves the problem, then you can stop performing the remaining actions.

See Chapter 3, "Parts listing," on page 197 to determine which components are CRUs and which components are FRUs.

B700 xxxx Error codes	Description	Action
5302	An unsupported Preferred Operating System was detected. The Preferred Operating System specified is not supported. The IPL will not continue.	Work with Bull support to select a supported Preferred Operating System; then, re-IPL the system.
5303	An unsupported Preferred Operating System was detected. The Preferred Operating System specified is not supported. The IPL will not continue.	Work with Bull support to select a supported Preferred Operating System; then, re-IPL the system.
5400	System firmware detected a problem with a processor.	Replace the system-board and chassis assembly, as described in "Replacing the Tier 2 system-board and chassis assembly" on page 229.
5442	System firmware detected an error.	Replace the system-board and chassis assembly, as described in "Replacing the Tier 2 system-board and chassis assembly" on page 229.
54DD	Informational system log entry only.	No corrective action is required.
5600	Informational system log entry only.	No corrective action is required.
5601	System firmware failure. There was a problem initializing, reading, or using system location codes.	Go to "Firmware problem isolation" on page 185.
6900	PCI host bridge failure	1. Replace the system-board and chassis assembly, as described in "Replacing the Tier 2 system-board and chassis assembly" on page 229. 2. If the problem persists, use the "PCI expansion card (PIOCARD) problem isolation procedure" on page 164 to determine the failing component.
6906	System bus error	Replace the system-board and chassis assembly, as described in "Replacing the Tier 2 system-board and chassis assembly" on page 229.
6907	System bus error	1. Replace the system-board and chassis assembly, as described in "Replacing the Tier 2 system-board and chassis assembly" on page 229. 2. Go to "Firmware problem isolation" on page 185.
6908	System bus error	Replace the system-board and chassis assembly, as described in "Replacing the Tier 2 system-board and chassis assembly" on page 229.
6909	System bus error	1. Replace the system-board and chassis assembly, as described in "Replacing the Tier 2 system-board and chassis assembly" on page 229. 2. Go to "Firmware problem isolation" on page 185.
6944	Informational system log entry only.	No corrective action is required.
6950	A platform dump has occurred.	1. Collect the platform dump information. 2. Go to "Firmware problem isolation" on page 185.
6951	An error occurred because a partition needed more NVRAM than was available.	Use the Integrated Virtualization Manager (IVM) to delete one or more partitions.
6952	Informational system log entry only.	No corrective action is required.
6953	PHYP NVRAM is unavailable after a service processor reset and reload.	Go to "Firmware problem isolation" on page 185.
6954	Informational system log entry only.	No corrective action is required.
6955	Informational system log entry only.	No corrective action is required.
6956	An NVRAM failure was detected.	Go to "Firmware problem isolation" on page 185.

Follow the suggested actions in the order in which they are listed in the Action column until the problem is solved. If an action solves the problem, then you can stop performing the remaining actions.

See Chapter 3, "Parts listing," on page 197 to determine which components are CRUs and which components are FRUs.

B700 xxxx Error codes	Description	Action
6965	Informational system log entry only.	No corrective action is required.
6970	PCI host bridge failure	<ol style="list-style-type: none"> 1. Replace the system-board and chassis assembly, as described in "Replacing the Tier 2 system-board and chassis assembly" on page 229. 2. If the problem persists, use the "PCI expansion card (PIOCARD) problem isolation procedure" on page 164 to determine the failing component.
6971	PCI bus failure	<ol style="list-style-type: none"> 1. Use the "PCI expansion card (PIOCARD) problem isolation procedure" on page 164 to determine the failing component. 2. If the problem persists, replace the system-board and chassis assembly, as described in "Replacing the Tier 2 system-board and chassis assembly" on page 229.
6972	System bus error	Replace the system-board and chassis assembly, as described in "Replacing the Tier 2 system-board and chassis assembly" on page 229.
6973	System bus error	<ol style="list-style-type: none"> 1. Use the "PCI expansion card (PIOCARD) problem isolation procedure" on page 164 to determine the failing component. 2. If the problem persists, replace the system-board and chassis assembly, as described in "Replacing the Tier 2 system-board and chassis assembly" on page 229.
6974	Informational system log entry only.	No corrective action is required.
6978	Informational system log entry only.	No corrective action is required.
6979	Informational system log entry only.	No corrective action is required.
697C	Connection from service processor to system processor failed.	Replace the system-board and chassis assembly, as described in "Replacing the Tier 2 system-board and chassis assembly" on page 229.
6980	Remote I/O (RIO), high-speed link (HSL), or 12X controller failure	Replace the system-board and chassis assembly, as described in "Replacing the Tier 2 system-board and chassis assembly" on page 229.
6981	System bus error.	Replace the system-board and chassis assembly, as described in "Replacing the Tier 2 system-board and chassis assembly" on page 229.
6984	Informational system log entry only.	No corrective action is required.
6985	Remote I/O (RIO), high-speed link (HSL), or 12X loop status message.	Replace the system-board and chassis assembly, as described in "Replacing the Tier 2 system-board and chassis assembly" on page 229.
6987	Remote I/O (RIO), high-speed link (HSL), or 12X connection failure	Replace the system-board and chassis assembly, as described in "Replacing the Tier 2 system-board and chassis assembly" on page 229.
6990	Service processor failure.	Replace the system-board and chassis assembly, as described in "Replacing the Tier 2 system-board and chassis assembly" on page 229.
6991	System firmware failure	Go to "Firmware problem isolation" on page 185.
6993	Service processor failure	<ol style="list-style-type: none"> 1. Replace the system-board and chassis assembly, as described in "Replacing the Tier 2 system-board and chassis assembly" on page 229. 2. Go to "Firmware problem isolation" on page 185.
6994	Service processor failure.	Replace the system-board and chassis assembly, as described in "Replacing the Tier 2 system-board and chassis assembly" on page 229.
6995	Informational system log entry only.	No corrective action is required.
69C2	Informational system log entry only.	No corrective action is required.

Follow the suggested actions in the order in which they are listed in the Action column until the problem is solved. If an action solves the problem, then you can stop performing the remaining actions.

See Chapter 3, "Parts listing," on page 197 to determine which components are CRUs and which components are FRUs.

B700 xxxx Error codes	Description	Action
69C3	Informational system log entry only.	No corrective action is required.
69D9	Host Ethernet Adapter (HEA) failure.	Replace the system-board and chassis assembly, as described in "Replacing the Tier 2 system-board and chassis assembly" on page 229.
69DA	Informational system log entry only.	No corrective action is required.
69DB	System firmware failure.	1. Collect the platform dump information. 2. Go to "Firmware problem isolation" on page 185.
BAD1	The platform firmware detected an error.	Go to "Firmware problem isolation" on page 185.
F103	System firmware failure	1. Collect the event log information. 2. Collect the platform dump information. 3. Go to "Firmware problem isolation" on page 185.
F104	Operating system error. System firmware terminated a partition.	Check the management-module event log for partition firmware error codes (especially BA00F104); then, take the appropriate actions for those error codes.
F105	System firmware detected an internal error	1. Collect the event log information. 2. Collect the platform dump information. 3. Go to "Firmware problem isolation" on page 185.
F106	System firmware detected an error	Replace the system-board and chassis assembly, as described in "Replacing the Tier 2 system-board and chassis assembly" on page 229.
F10A	System firmware detected an error	Look for and correct B1xxxxxx errors.
F10B	A processor resource has been disabled due to hardware problems	Replace the system-board and chassis assembly, as described in "Replacing the Tier 2 system-board and chassis assembly" on page 229.
F120	Informational system log entry only.	No corrective action is required.

2.4.1.10 BA000010 to BA400002 Partition firmware SRCs

The power-on self-test (POST) might display an error code that the partition firmware detects. Try to correct the problem with the suggested action.

Table 2-13 describes error codes that might be displayed if POST detects a problem. The description also includes suggested actions to correct the problem.

Note For problems persisting after completing the suggested actions, see "Checkout procedure" on page 148 and "Solving undetermined problems" on page 194.

Table 2-13. BA000010 to BA400002 Partition firmware SRCs

<ul style="list-style-type: none"> Follow the suggested actions in the order in which they are listed in the Action column until the problem is solved. If an action solves the problem, then you can stop performing the remaining actions. See <i>Chapter 3, "Parts listing,"</i> on page 197 to determine which components are CRUs and which components are FRUs. 		
Error code	Description	Action
BA000010	The device data structure is corrupted	<ol style="list-style-type: none"> Go to "Checkout procedure" on page 148. Replace the system-board and chassis assembly, as described in "Replacing the Tier 2 system-board and chassis assembly" on page 229.
BA000020	Incompatible firmware levels were found	<ol style="list-style-type: none"> Reboot the blade server. If the problem persists: <ol style="list-style-type: none"> Go to "Checkout procedure" on page 148. Replace the system-board and chassis assembly, as described in "Replacing the Tier 2 system-board and chassis assembly" on page 229.
BA000030	An lpevent communication failure occurred	<ol style="list-style-type: none"> Go to "Checkout procedure" on page 148. Replace the system-board and chassis assembly, as described in "Replacing the Tier 2 system-board and chassis assembly" on page 229.
BA000031	An lpevent communication failure occurred	<ol style="list-style-type: none"> Go to "Checkout procedure" on page 148. Replace the system-board and chassis assembly, as described in "Replacing the Tier 2 system-board and chassis assembly" on page 229.
BA000032	The firmware failed to register the lpevent queues	<ol style="list-style-type: none"> Reboot the blade server. If the problem persists: <ol style="list-style-type: none"> Go to "Checkout procedure" on page 148. Replace the system-board and chassis assembly, as described in "Replacing the Tier 2 system-board and chassis assembly" on page 229.
BA000034	The firmware failed to exchange capacity and allocate lpevents	<ol style="list-style-type: none"> Reboot the blade server. If the problem persists: <ol style="list-style-type: none"> Go to "Checkout procedure" on page 148. Replace the system-board and chassis assembly, as described in "Replacing the Tier 2 system-board and chassis assembly" on page 229.
BA000038	The firmware failed to exchange virtual continuation events	<ol style="list-style-type: none"> Reboot the blade server. If the problem persists: <ol style="list-style-type: none"> Go to "Checkout procedure" on page 148. Replace the system-board and chassis assembly, as described in "Replacing the Tier 2 system-board and chassis assembly" on page 229.
BA000040	The firmware was unable to obtain the RTAS code lid details	<ol style="list-style-type: none"> Reboot the blade server. If the problem persists: <ol style="list-style-type: none"> Go to "Checkout procedure" on page 148. Replace the system-board and chassis assembly, as described in "Replacing the Tier 2 system-board and chassis assembly" on page 229.
BA000050	The firmware was unable to load the RTAS code lid	<ol style="list-style-type: none"> Reboot the blade server. If the problem persists: <ol style="list-style-type: none"> Go to "Checkout procedure" on page 148. Replace the system-board and chassis assembly, as described in "Replacing the Tier 2 system-board and chassis assembly" on page 229.

- Follow the suggested actions in the order in which they are listed in the Action column until the problem is solved. If an action solves the problem, then you can stop performing the remaining actions.
- See Chapter 3, "Parts listing," on page 197 to determine which components are CRUs and which components are FRUs.

Error code	Description	Action
BA000060	The firmware was unable to obtain the open firmware code lid details	<ol style="list-style-type: none"> 1. Reboot the blade server. 2. If the problem persists: <ol style="list-style-type: none"> a. Go to "Checkout procedure" on page 148. b. Replace the system-board and chassis assembly, as described in "Replacing the Tier 2 system-board and chassis assembly" on page 229.
BA000070	The firmware was unable to load the open firmware code lid	<ol style="list-style-type: none"> 1. Reboot the blade server. 2. If the problem persists: <ol style="list-style-type: none"> a. Go to "Checkout procedure" on page 148. b. Replace the system-board and chassis assembly, as described in "Replacing the Tier 2 system-board and chassis assembly" on page 229.
BA000080	The user did not accept the license agreement	<p>Accept the license agreement and restart the blade server.</p> <p>If the problem persists:</p> <ol style="list-style-type: none"> 1. Go to "Checkout procedure" on page 148. 2. Replace the system-board and chassis assembly, as described in "Replacing the Tier 2 system-board and chassis assembly" on page 229.
BA000081	Failed to get the firmware license policy	<ol style="list-style-type: none"> 1. Reboot the blade server. 2. If the problem persists: <ol style="list-style-type: none"> a. Go to "Checkout procedure" on page 148. b. Replace the system-board and chassis assembly, as described in "Replacing the Tier 2 system-board and chassis assembly" on page 229.
BA000082	Failed to set the firmware license policy	<ol style="list-style-type: none"> 1. Reboot the blade server. 2. If the problem persists: <ol style="list-style-type: none"> a. Go to "Checkout procedure" on page 148. b. Replace the system-board and chassis assembly, as described in "Replacing the Tier 2 system-board and chassis assembly" on page 229.
BA000091	Unable to load a firmware code update module	<ol style="list-style-type: none"> 1. Reboot the blade server. 2. If the problem persists: <ol style="list-style-type: none"> a. Go to "Checkout procedure" on page 148. b. Replace the system-board and chassis assembly, as described in "Replacing the Tier 2 system-board and chassis assembly" on page 229.
BA00E820	An Ipevent communication failure occurred	<ol style="list-style-type: none"> 1. Go to "Checkout procedure" on page 148. 2. Replace the system-board and chassis assembly, as described in "Replacing the Tier 2 system-board and chassis assembly" on page 229.
BA00E830	Failure when initializing event-scan	<ol style="list-style-type: none"> 1. Go to "Checkout procedure" on page 148. 2. Replace the system-board and chassis assembly, as described in "Replacing the Tier 2 system-board and chassis assembly" on page 229.
BA00E840	Failure when initializing PCI hot-plug	<ol style="list-style-type: none"> 1. Go to "Checkout procedure" on page 148. 2. Replace the system-board and chassis assembly, as described in "Replacing the Tier 2 system-board and chassis assembly" on page 229.

- Follow the suggested actions in the order in which they are listed in the Action column until the problem is solved. If an action solves the problem, then you can stop performing the remaining actions.
- See *Chapter 3, "Parts listing,"* on page 197 to determine which components are CRUs and which components are FRUs.

Error code	Description	Action
BA00E843	Failure when initializing the interface to AIX or Linux	<ol style="list-style-type: none"> 1. Go to "Checkout procedure" on page 148. 2. Replace the system-board and chassis assembly, as described in "Replacing the Tier 2 system-board and chassis assembly" on page 229.
BA00E850	Failure when initializing dynamic reconfiguration	<ol style="list-style-type: none"> 1. Go to "Checkout procedure" on page 148. 2. Replace the system-board and chassis assembly, as described in "Replacing the Tier 2 system-board and chassis assembly" on page 229.
BA00E860	Failure when initializing sensors	<ol style="list-style-type: none"> 1. Go to "Checkout procedure" on page 148. 2. Replace the system-board and chassis assembly, as described in "Replacing the Tier 2 system-board and chassis assembly" on page 229.
BA010000	There is insufficient information to boot the systems	<ol style="list-style-type: none"> 1. Go to "Checkout procedure" on page 148. 2. Replace the system-board and chassis assembly, as described in "Replacing the Tier 2 system-board and chassis assembly" on page 229.
BA010001	The client IP address is already in use by another network device	Verify that all of the IP addresses on the network are unique; then, retry the operation.
BA010002	Cannot get gateway IP address	<p>Perform the following actions that checkpoint CA00E174 describes:</p> <ol style="list-style-type: none"> 1. Verify that: <ul style="list-style-type: none"> – The bootp server is correctly configured; then, retry the operation. – The network connections are correct; then, retry the operation. 2. If the problem persists: <ol style="list-style-type: none"> a. Go to "Checkout procedure" on page 148. b. Replace the system-board and chassis assembly, as described in "Replacing the Tier 2 system-board and chassis assembly" on page 229.
BA010003	Cannot get server hardware address	<p>Perform the following actions that checkpoint CA00E174 describes:</p> <ol style="list-style-type: none"> 1. Verify that: <ul style="list-style-type: none"> – The bootp server is correctly configured; then, retry the operation. – The network connections are correct; then, retry the operation. 2. If the problem persists: <ol style="list-style-type: none"> a. Go to "Checkout procedure" on page 148. b. Replace the system-board and chassis assembly, as described in "Replacing the Tier 2 system-board and chassis assembly" on page 229.

- Follow the suggested actions in the order in which they are listed in the Action column until the problem is solved. If an action solves the problem, then you can stop performing the remaining actions.
- See Chapter 3, "Parts listing," on page 197 to determine which components are CRUs and which components are FRUs.

Error code	Description	Action
BA010004	Bootp failed	Perform the following actions that checkpoint CA00E174 describes: 1. Verify that: <ul style="list-style-type: none"> – The bootp server is correctly configured; then, retry the operation. – The network connections are correct; then, retry the operation. 2. If the problem persists: <ol style="list-style-type: none"> Go to "Checkout procedure" on page 148. Replace the system-board and chassis assembly, as described in "Replacing the Tier 2 system-board and chassis assembly" on page 229.
BA010005	File transmission (TFTP) failed	Perform the following actions that checkpoint CA00E174 describes: 1. Verify that: <ul style="list-style-type: none"> – The bootp server is correctly configured; then, retry the operation. – The network connections are correct; then, retry the operation. 2. If the problem persists: <ol style="list-style-type: none"> Go to "Checkout procedure" on page 148. Replace the system-board and chassis assembly, as described in "Replacing the Tier 2 system-board and chassis assembly" on page 229.
BA010006	The boot image is too large	Start up from another device with a bootable image.
BA010007	The device does not have the required device_type property.	1. Reboot the blade server. 2. If the problem persists: <ol style="list-style-type: none"> Go to "Checkout procedure" on page 148. Replace the system-board and chassis assembly, as described in "Replacing the Tier 2 system-board and chassis assembly" on page 229.
BA010008	The device_type property for this device is not supported by the iSCSI initiator configuration specification.	1. Reboot the blade server. 2. If the problem persists: <ol style="list-style-type: none"> Go to "Checkout procedure" on page 148. Replace the system-board and chassis assembly, as described in "Replacing the Tier 2 system-board and chassis assembly" on page 229.
BA010009	The arguments specified for the ping function are invalid.	The embedded host Ethernet adapters (HEAs) help provide iSCSI, which is supported by iSCSI software device drivers on either AIX or Linux. Verify that all of the iSCSI configuration arguments on the operating system comply with the configuration for the iSCSI Host Bus Adapter (HBA), which is the <i>iSCSI initiator</i> .
BA01000A	The itname parameter string exceeds the maximum length allowed.	The embedded host Ethernet adapters (HEAs) help provide iSCSI, which is supported by iSCSI software device drivers on either AIX or Linux. Verify that all of the iSCSI configuration arguments on the operating system comply with the configuration for the iSCSI Host Bus Adapter (HBA), which is the <i>iSCSI initiator</i> .

- Follow the suggested actions in the order in which they are listed in the Action column until the problem is solved. If an action solves the problem, then you can stop performing the remaining actions.
- See *Chapter 3, "Parts listing,"* on page 197 to determine which components are CRUs and which components are FRUs.

Error code	Description	Action
BA01000B	The ichapid parameter string exceeds the maximum length allowed.	The embedded host Ethernet adapters (HEAs) help provide iSCSI, which is supported by iSCSI software device drivers on either AIX or Linux. Verify that all of the iSCSI configuration arguments on the operating system comply with the configuration for the iSCSI Host Bus Adapter (HBA), which is the <i>iSCSI initiator</i> .
BA01000C	The ichappw parameter string exceeds the maximum length allowed.	The embedded host Ethernet adapters (HEAs) help provide iSCSI, which is supported by iSCSI software device drivers on either AIX or Linux. Verify that all of the iSCSI configuration arguments on the operating system comply with the configuration for the iSCSI Host Bus Adapter (HBA), which is the <i>iSCSI initiator</i> .
BA01000D	The iname parameter string exceeds the maximum length allowed.	The embedded host Ethernet adapters (HEAs) help provide iSCSI, which is supported by iSCSI software device drivers on either AIX or Linux. Verify that all of the iSCSI configuration arguments on the operating system comply with the configuration for the iSCSI Host Bus Adapter (HBA), which is the <i>iSCSI initiator</i> .
BA01000E	The LUN specified is not valid.	The embedded host Ethernet adapters (HEAs) help provide iSCSI, which is supported by iSCSI software device drivers on either AIX or Linux. Verify that all of the iSCSI configuration arguments on the operating system comply with the configuration for the iSCSI Host Bus Adapter (HBA), which is the <i>iSCSI initiator</i> .
BA01000F	The chapid parameter string exceeds the maximum length allowed.	The embedded host Ethernet adapters (HEAs) help provide iSCSI, which is supported by iSCSI software device drivers on either AIX or Linux. Verify that all of the iSCSI configuration arguments on the operating system comply with the configuration for the iSCSI Host Bus Adapter (HBA), which is the <i>iSCSI initiator</i> .
BA010010	The chappw parameter string exceeds the maximum length allowed.	The embedded host Ethernet adapters (HEAs) help provide iSCSI, which is supported by iSCSI software device drivers on either AIX or Linux. Verify that all of the iSCSI configuration arguments on the operating system comply with the configuration for the iSCSI Host Bus Adapter (HBA), which is the <i>iSCSI initiator</i> .
BA010011	SET-ROOT-PROP could not find / (root) package	<ol style="list-style-type: none"> 1. Reboot the blade server. 2. If the problem persists: <ol style="list-style-type: none"> a. Go to "<i>Checkout procedure</i>" on page 148. b. Replace the system-board and chassis assembly, as described in "<i>Replacing the Tier 2 system-board and chassis assembly</i>" on page 229.
BA010013	The information in the error log entry for this SRC provides network trace data.	Informational message. No action is required.
BA010014	The information in the error log entry for this SRC provides network trace data.	Informational message. No action is required.
BA010015	The information in the error log entry for this SRC provides network trace data.	Informational message. No action is required.
BA010020	A trace entry addition failed because of a bad trace type.	<ol style="list-style-type: none"> 1. Reboot the blade server. 2. If the problem persists: <ol style="list-style-type: none"> a. Go to "<i>Checkout procedure</i>" on page 148. b. Replace the system-board and chassis assembly, as described in "<i>Replacing the Tier 2 system-board and chassis assembly</i>" on page 229.

- Follow the suggested actions in the order in which they are listed in the Action column until the problem is solved. If an action solves the problem, then you can stop performing the remaining actions.
- See *Chapter 3, "Parts listing,"* on page 197 to determine which components are CRUs and which components are FRUs.

Error code	Description	Action
BA012010	Opening the TCP node failed.	<ol style="list-style-type: none"> 1. Reboot the blade server. 2. If the problem persists: <ol style="list-style-type: none"> a. Go to "Checkout procedure" on page 148. b. Replace the system-board and chassis assembly, as described in "Replacing the Tier 2 system-board and chassis assembly" on page 229.
BA012011	TCP failed to read from the network	<ol style="list-style-type: none"> 1. Reboot the blade server. 2. If the problem persists: <ol style="list-style-type: none"> a. Go to "Checkout procedure" on page 148. b. Replace the system-board and chassis assembly, as described in "Replacing the Tier 2 system-board and chassis assembly" on page 229.
BA012012	TCP failed to write to the network.	<ol style="list-style-type: none"> 1. Reboot the blade server. 2. If the problem persists: <ol style="list-style-type: none"> a. Go to "Checkout procedure" on page 148. b. Replace the system-board and chassis assembly, as described in "Replacing the Tier 2 system-board and chassis assembly" on page 229.
BA012013	Closing TCP failed.	<ol style="list-style-type: none"> 1. Reboot the blade server. 2. If the problem persists: <ol style="list-style-type: none"> a. Go to "Checkout procedure" on page 148. b. Replace the system-board and chassis assembly, as described in "Replacing the Tier 2 system-board and chassis assembly" on page 229.
BA017020	Failed to open the TFTP package	Verify that the Trivial File Transfer Protocol (TFTP) parameters are correct.
BA017021	Failed to load the TFTP file	Verify that the TFTP server and network connections are correct.
BA01B010	Opening the BOOTP node failed.	<ol style="list-style-type: none"> 1. Reboot the blade server. 2. If the problem persists: <ol style="list-style-type: none"> a. Go to "Checkout procedure" on page 148. b. Replace the system-board and chassis assembly, as described in "Replacing the Tier 2 system-board and chassis assembly" on page 229.
BA01B011	BOOTP failed to read from the network	<p>Perform the following actions that checkpoint CA00E174 describes:</p> <ol style="list-style-type: none"> 1. Verify that: <ul style="list-style-type: none"> – The bootp server is correctly configured; then, retry the operation. – The network connections are correct; then, retry the operation. 2. If the problem persists: <ol style="list-style-type: none"> a. Go to "Checkout procedure" on page 148. b. Replace the system-board and chassis assembly, as described in "Replacing the Tier 2 system-board and chassis assembly" on page 229.

- Follow the suggested actions in the order in which they are listed in the Action column until the problem is solved. If an action solves the problem, then you can stop performing the remaining actions.
- See *Chapter 3, "Parts listing,"* on page 197 to determine which components are CRUs and which components are FRUs.

Error code	Description	Action
BA01B012	BOOTP failed to write to the network	<p>Perform the following actions that checkpoint CA00E174 describes:</p> <ol style="list-style-type: none"> 1. Verify that: <ul style="list-style-type: none"> – The bootp server is correctly configured; then, retry the operation. – The network connections are correct; then, retry the operation. 2. If the problem persists: <ol style="list-style-type: none"> a. Go to <i>"Checkout procedure"</i> on page 148. b. Replace the system-board and chassis assembly, as described in <i>"Replacing the Tier 2 system-board and chassis assembly"</i> on page 229.
BA01B013	The discover mode is invalid	<ol style="list-style-type: none"> 1. Reboot the blade server. 2. If the problem persists: <ol style="list-style-type: none"> a. Go to <i>"Checkout procedure"</i> on page 148. b. Replace the system-board and chassis assembly, as described in <i>"Replacing the Tier 2 system-board and chassis assembly"</i> on page 229.
BA01B014	Closing the BOOTP node failed	<ol style="list-style-type: none"> 1. Reboot the blade server. 2. If the problem persists: <ol style="list-style-type: none"> a. Go to <i>"Checkout procedure"</i> on page 148. b. Replace the system-board and chassis assembly, as described in <i>"Replacing the Tier 2 system-board and chassis assembly"</i> on page 229.
BA01B015	The BOOTP discover server timed out	<p>Perform the following actions that checkpoint CA00E174 describes:</p> <ol style="list-style-type: none"> 1. Verify that: <ul style="list-style-type: none"> – The bootp server is correctly configured; then, retry the operation. – The network connections are correct; then, retry the operation. 2. If the problem persists: <ol style="list-style-type: none"> a. Go to <i>"Checkout procedure"</i> on page 148. b. Replace the system-board and chassis assembly, as described in <i>"Replacing the Tier 2 system-board and chassis assembly"</i> on page 229.
BA01D001	Opening the DHCP node failed	<ol style="list-style-type: none"> 1. Reboot the blade server. 2. If the problem persists: <ol style="list-style-type: none"> a. Go to <i>"Checkout procedure"</i> on page 148. b. Replace the system-board and chassis assembly, as described in <i>"Replacing the Tier 2 system-board and chassis assembly"</i> on page 229.
BA01D020	DHCP failed to read from the network	<ol style="list-style-type: none"> 1. Verify that the network cable is connected, and that the network is active. 2. If the problem persists: <ol style="list-style-type: none"> a. Go to <i>"Checkout procedure"</i> on page 148. b. Replace the system-board and chassis assembly, as described in <i>"Replacing the Tier 2 system-board and chassis assembly"</i> on page 229.

- Follow the suggested actions in the order in which they are listed in the Action column until the problem is solved. If an action solves the problem, then you can stop performing the remaining actions.
- See Chapter 3, "Parts listing," on page 197 to determine which components are CRUs and which components are FRUs.

Error code	Description	Action
BA01D030	DHCP failed to write to the network	<ol style="list-style-type: none"> 1. Verify that the network cable is connected, and that the network is active. 2. If the problem persists: <ol style="list-style-type: none"> a. Go to "Checkout procedure" on page 148. b. Replace the system-board and chassis assembly, as described in "Replacing the Tier 2 system-board and chassis assembly" on page 229.
BA01D040	The DHCP discover server timed out	<ol style="list-style-type: none"> 1. Verify that the DHCP server has addresses available. 2. Verify that the DHCP server configuration file is not overly constrained. An over-constrained file might prevent a server from meeting the configuration requested by the client. 3. Perform the following actions that checkpoint CA00E174 describes: <ol style="list-style-type: none"> a. Verify that: <ul style="list-style-type: none"> – The bootp server is correctly configured; then, retry the operation. – The network connections are correct; then, retry the operation. b. If the problem persists: <ol style="list-style-type: none"> i. Go to "Checkout procedure" on page 148. ii. Replace the system-board and chassis assembly, as described in "Replacing the Tier 2 system-board and chassis assembly" on page 229.
BA01D050	DHCP::discover no good offer	<p>DHCP discovery did not receive any DHCP offers from the servers that meet the client requirements.</p> <p>Verify that the DHCP server configuration file is not overly constrained. An over-constrained file might prevent a server from meeting the configuration requested by the client.</p>
BA01D051	DHCP::discover DHCP request timed out	<p>DHCP discovery did receive a DHCP offer from a server that met the client requirements, but the server did not send the DHCP acknowledgement (DHCP ack) to the client DHCP request.</p> <p>Another client might have used the address that was served.</p> <p>Verify that the DHCP server has addresses available.</p>
BA01D052	DHCP::discover: 10 incapable servers were found	<p>Ten DHCP servers have sent DHCP offers, none of which met the requirements of the client. Check the compatibility of the configuration that the client is requesting and the server DHCP configuration files.</p>
BA01D053	DHCP::discover received a reply, but without a message type	<p>Verify that the DHCP server is properly configured.</p>
BA01D054	DHCP::discover: DHCP nak received	<p>DHCP discovery did receive a DHCP offer from a server that meets the client requirements, but the server sent a DHCP not acknowledged (DHCP nak) to the client DHCP request.</p> <p>Another client might be using the address that was served.</p> <p>This situation can occur when there are multiple DHCP servers on the same network, and server A does not know the subnet configuration of server B, and vice-versa.</p> <p>This situation can also occur when the pool of addresses is not truly divided.</p> <p>Set the DHCP server configuration file to "authoritative".</p> <p>Verify that the DHCP server is functioning properly.</p>

- Follow the suggested actions in the order in which they are listed in the Action column until the problem is solved. If an action solves the problem, then you can stop performing the remaining actions.
- See *Chapter 3, "Parts listing,"* on page 197 to determine which components are CRUs and which components are FRUs.

Error code	Description	Action
BA01D055	DHCP::discover: DHCP decline	DHCP discovery did receive a DHCP offer from one or more servers that meet the client requirements. However, the client performed an ARP test on the address and found that another client was using the address. The client sent a DHCP decline to the server, but the client did not receive an additional DHCP offer from a server. The client still does not have a valid address. Verify that the DHCP server is functioning properly.
BA01D056	DHCP::discover: unknown DHCP message	DHCP discovery received an unknown DHCP message type. Verify that the DHCP server is functioning properly.
BA01D0FF	Closing the DHCP node failed.	1. Reboot the blade server. 2. If the problem persists: a. Go to "Checkout procedure" on page 148. b. Replace the system-board and chassis assembly, as described in "Replacing the Tier 2 system-board and chassis assembly" on page 229.
BA030011	RTAS attempt to allocate memory failed	1. Go to "Checkout procedure" on page 148. 2. Replace the system-board and chassis assembly, as described in "Replacing the Tier 2 system-board and chassis assembly" on page 229.
BA04000F	Self test failed on device; no error or location code information available	1. If a location code is identified with the error, replace the device specified by the location code. 2. If the problem persists: a. Go to "Checkout procedure" on page 148. b. Replace the system-board and chassis assembly, as described in "Replacing the Tier 2 system-board and chassis assembly" on page 229.
BA040010	Self test failed on device; can't locate package	1. If a location code is identified with the error, replace the device specified by the location code. 2. If the problem persists: a. Go to "Checkout procedure" on page 148. b. Replace the system-board and chassis assembly, as described in "Replacing the Tier 2 system-board and chassis assembly" on page 229.
BA040020	The machine type and model are not recognized by the blade server firmware	1. Reboot the blade server. 2. If the problem persists: a. Go to "Checkout procedure" on page 148. b. Replace the system-board and chassis assembly, as described in "Replacing the Tier 2 system-board and chassis assembly" on page 229.
BA040030	The firmware was not able to build the UID properly for this system. As a result, problems may occur with the licensing of the AIX operating system	1. Go to "Checkout procedure" on page 148. 2. Replace the system-board and chassis assembly, as described in "Replacing the Tier 2 system-board and chassis assembly" on page 229.
BA040035	The firmware was unable to find the "plant of manufacture" in the VPD. This may cause problems with the licensing of the AIX operating system.	Verify that the machine type, model, and serial number are correct for this server. If this is a new server, check for server firmware updates; then, install the updates if available.
BA040040	Setting the machine type, model, and serial number failed.	1. Go to "Checkout procedure" on page 148. 2. Replace the system-board and chassis assembly, as described in "Replacing the Tier 2 system-board and chassis assembly" on page 229.

- Follow the suggested actions in the order in which they are listed in the Action column until the problem is solved. If an action solves the problem, then you can stop performing the remaining actions.
- See Chapter 3, "Parts listing," on page 197 to determine which components are CRUs and which components are FRUs.

Error code	Description	Action
BA040050	The h-call to switch off the boot watchdog timer failed.	1. Go to "Checkout procedure" on page 148. 2. Replace the system-board and chassis assembly, as described in "Replacing the Tier 2 system-board and chassis assembly" on page 229.
BA040060	Setting the firmware boot side for the next boot failed.	1. Go to "Checkout procedure" on page 148. 2. Replace the system-board and chassis assembly, as described in "Replacing the Tier 2 system-board and chassis assembly" on page 229.
BA050001	Failed to reboot a partition in logical partition mode	1. Go to "Checkout procedure" on page 148. 2. Replace the system-board and chassis assembly, as described in "Replacing the Tier 2 system-board and chassis assembly" on page 229.
BA050004	Failed to locate service processor device tree node.	1. Go to "Checkout procedure" on page 148. 2. Replace the system-board and chassis assembly, as described in "Replacing the Tier 2 system-board and chassis assembly" on page 229.
BA05000A	Failed to send boot failed message	1. Go to "Checkout procedure" on page 148. 2. Replace the system-board and chassis assembly, as described in "Replacing the Tier 2 system-board and chassis assembly" on page 229.
BA060008	No configurable adapters found by the Remote IPL menu in the SMS utilities	This error occurs when the firmware cannot locate any LAN adapters that are supported by the remote IPL function. Verify that the devices in the remote IPL device list are correct using the SMS menus.
BA06000B	The system was not able to find an operating system on the devices in the boot list.	go to "Boot problem resolution" on page 156.
BA06000C	A pointer to the operating system was found in non-volatile storage.	1. Go to "Checkout procedure" on page 148. 2. Replace the system-board and chassis assembly, as described in "Replacing the Tier 2 system-board and chassis assembly" on page 229.
BA060020	The environment variable "boot-device" exceeded the allowed character limit.	1. Go to "Checkout procedure" on page 148. 2. Replace the system-board and chassis assembly, as described in "Replacing the Tier 2 system-board and chassis assembly" on page 229.
BA060021	The environment variable "boot-device" contained more than five entries.	1. Go to "Checkout procedure" on page 148. 2. Replace the system-board and chassis assembly, as described in "Replacing the Tier 2 system-board and chassis assembly" on page 229.
BA060022	The environment variable "boot-device" contained an entry that exceeded 255 characters in length	1. Using the SMS menus, set the boot list to the default boot list. 2. Shut down; then, start up the blade server. 3. Use SMS menus to customize the boot list as required. 4. If the problem persists: a. Go to "Checkout procedure" on page 148. b. Replace the system-board and chassis assembly, as described in "Replacing the Tier 2 system-board and chassis assembly" on page 229.

- Follow the suggested actions in the order in which they are listed in the Action column until the problem is solved. If an action solves the problem, then you can stop performing the remaining actions.
- See *Chapter 3, "Parts listing,"* on page 197 to determine which components are CRUs and which components are FRUs.

Error code	Description	Action
BA060030	Logical partitioning with shared processors is enabled and the operating system does not support it.	<ol style="list-style-type: none"> 1. Install or boot a level of the operating system that supports shared processors. 2. Disable logical partitioning with shared processors in the operating system. 3. If the problem remains: <ol style="list-style-type: none"> a. Go to "Checkout procedure" on page 148. b. Replace the system-board and chassis assembly, as described in "Replacing the Tier 2 system-board and chassis assembly" on page 229.
BA060060	The operating system expects an IOSP partition, but it failed to make the transition to alpha mode.	<ol style="list-style-type: none"> 1. Verify that: <ul style="list-style-type: none"> The alpha-mode operating system image is intended for this partition. The configuration of the partition supports an alpha-mode operating system. 2. If the problem remains: <ol style="list-style-type: none"> a. Go to "Checkout procedure" on page 148. b. Replace the system-board and chassis assembly, as described in "Replacing the Tier 2 system-board and chassis assembly" on page 229.
BA060061	The operating system expects a non-IOSP partition, but it failed to make the transition to MGC mode.	<ol style="list-style-type: none"> 1. Verify that: <ul style="list-style-type: none"> The alpha-mode operating system image is intended for this partition. The configuration of the partition supports an alpha-mode operating system. 2. If the problem remains: <ol style="list-style-type: none"> a. Go to "Checkout procedure" on page 148. b. Replace the system-board and chassis assembly, as described in "Replacing the Tier 2 system-board and chassis assembly" on page 229.
BA060070	The operating system does not support this system's processor(s)	Boot a supported version of the operating system.
BA060071	An invalid number of vectors was received from the operating system	Boot a supported version of the operating system.
BA060072	Clent-arch-support hcall error	<ol style="list-style-type: none"> 1. Go to "Checkout procedure" on page 148. 2. Replace the system-board and chassis assembly, as described in "Replacing the Tier 2 system-board and chassis assembly" on page 229.
BA060075	Clent-arch-support firmware error	<ol style="list-style-type: none"> 1. Go to "Checkout procedure" on page 148. 2. Replace the system-board and chassis assembly, as described in "Replacing the Tier 2 system-board and chassis assembly" on page 229.
BA060200	Failed to set the operating system boot list from the management module boot list	<ol style="list-style-type: none"> 1. Using the SMS menus, set the boot list to the default boot list. 2. Shut down; then, start up the blade server. 3. Use SMS menus to customize the boot list as required. 4. If the problem persists: <ol style="list-style-type: none"> a. Go to "Checkout procedure" on page 148. b. Replace the system-board and chassis assembly, as described in "Replacing the Tier 2 system-board and chassis assembly" on page 229.
BA060201	Failed to read the VPD [boot path] field value	<ol style="list-style-type: none"> 1. Go to "Checkout procedure" on page 148. 2. Replace the system-board and chassis assembly, as described in "Replacing the Tier 2 system-board and chassis assembly" on page 229.

- Follow the suggested actions in the order in which they are listed in the Action column until the problem is solved. If an action solves the problem, then you can stop performing the remaining actions.
- See *Chapter 3, "Parts listing,"* on page 197 to determine which components are CRUs and which components are FRUs.

Error code	Description	Action
BA060202	Failed to update the VPD with the new □boot path□ field value	<ol style="list-style-type: none"> 1. Go to "Checkout procedure" on page 148. 2. Replace the system-board and chassis assembly, as described in "Replacing the Tier 2 system-board and chassis assembly" on page 229.
BA060300	An I/O error on the adapter from which the boot was attempted prevented the operating system from being booted.	<ol style="list-style-type: none"> 1. Using the SMS menus, select another adapter from which to boot the operating system, and reboot the system. 2. Attempt to reboot the system. 3. go to "Boot problem resolution" on page 156.
BA07xxxx	Self configuring SCSI device (SCSD) controller failure.	<ol style="list-style-type: none"> 1. Go to "Checkout procedure" on page 148. 2. Replace the system-board and chassis assembly, as described in "Replacing the Tier 2 system-board and chassis assembly" on page 229.
BA090001	SCSI DASD: test unit ready failed; hardware error	<ol style="list-style-type: none"> 1. Go to "Checkout procedure" on page 148. 2. Replace the system-board and chassis assembly, as described in "Replacing the Tier 2 system-board and chassis assembly" on page 229.
BA090002	SCSI DASD: test unit ready failed; sense data available	<ol style="list-style-type: none"> 1. Go to "Checkout procedure" on page 148. 2. Replace the system-board and chassis assembly, as described in "Replacing the Tier 2 system-board and chassis assembly" on page 229.
BA090003	SCSI DASD: send diagnostic failed; sense data available	<ol style="list-style-type: none"> 1. Go to "Checkout procedure" on page 148. 2. Replace the system-board and chassis assembly, as described in "Replacing the Tier 2 system-board and chassis assembly" on page 229.
BA090004	SCSI DASD: send diagnostic failed: devofl cmd	<ol style="list-style-type: none"> 1. Go to "Checkout procedure" on page 148. 2. Replace the system-board and chassis assembly, as described in "Replacing the Tier 2 system-board and chassis assembly" on page 229.
BA09000A	There was a vendor specification error.	<ol style="list-style-type: none"> 1. Check the vendor specification for additional information. 2. If the problem persists: <ol style="list-style-type: none"> a. Go to "Checkout procedure" on page 148. b. Replace the system-board and chassis assembly, as described in "Replacing the Tier 2 system-board and chassis assembly" on page 229.
BA09000B	Generic SCSD sense error	<ol style="list-style-type: none"> 1. Verify that the SCSD cables and devices are properly plugged. 2. Correct any problems that are found. 3. If the problem persists: <ol style="list-style-type: none"> a. Go to "Checkout procedure" on page 148. b. Replace the system-board and chassis assembly, as described in "Replacing the Tier 2 system-board and chassis assembly" on page 229.
BA09000C	The media is write-protected	<ol style="list-style-type: none"> 1. Change the setting of the media to allow writing, then retry the operation. 2. Insert new media of the correct type. 3. If the problem persists: <ol style="list-style-type: none"> a. Go to "Checkout procedure" on page 148. b. Replace the system-board and chassis assembly, as described in "Replacing the Tier 2 system-board and chassis assembly" on page 229.

- Follow the suggested actions in the order in which they are listed in the Action column until the problem is solved. If an action solves the problem, then you can stop performing the remaining actions.
- See *Chapter 3, "Parts listing,"* on page 197 to determine which components are CRUs and which components are FRUs.

Error code	Description	Action
BA09000D	The media is unsupported or not recognized.	<ol style="list-style-type: none"> 1. Insert new media of the correct type. 2. If the problem persists: <ol style="list-style-type: none"> a. Go to "Checkout procedure" on page 148. b. Replace the system-board and chassis assembly, as described in "Replacing the Tier 2 system-board and chassis assembly" on page 229.
BA09000E	The media is not formatted correctly.	<ol style="list-style-type: none"> 1. Insert the media. 2. Insert new media of the correct type. 3. If the problem persists: <ol style="list-style-type: none"> a. Go to "Checkout procedure" on page 148. b. Replace the system-board and chassis assembly, as described in "Replacing the Tier 2 system-board and chassis assembly" on page 229.
BA09000F	Media is not present	<ol style="list-style-type: none"> 1. Insert new media with the correct format. 2. If the problem persists: <ol style="list-style-type: none"> a. Go to "Checkout procedure" on page 148. b. Replace the system-board and chassis assembly, as described in "Replacing the Tier 2 system-board and chassis assembly" on page 229.
BA090010	The request sense command failed.	<ol style="list-style-type: none"> 1. Troubleshoot the SCSD devices. 2. Verify that the SCSD cables and devices are properly plugged. Correct any problems that are found. 3. Replace the SCSD cables and devices. 4. If the problem persists: <ol style="list-style-type: none"> a. Go to "Checkout procedure" on page 148. b. Replace the system-board and chassis assembly, as described in "Replacing the Tier 2 system-board and chassis assembly" on page 229.
BA090011	The retry limit has been exceeded.	<ol style="list-style-type: none"> 1. Troubleshoot the SCSD devices. 2. Verify that the SCSD cables and devices are properly plugged. Correct any problems that are found. 3. Replace the SCSD cables and devices. 4. If the problem persists: <ol style="list-style-type: none"> a. Go to "Checkout procedure" on page 148. b. Replace the system-board and chassis assembly, as described in "Replacing the Tier 2 system-board and chassis assembly" on page 229.
BA090012	There is a SCSD device that is not supported.	<ol style="list-style-type: none"> 1. Replace the SCSD device that is not supported with a supported device. 2. If the problem persists: <ol style="list-style-type: none"> a. Troubleshoot the SCSD devices. b. Verify that the SCSD cables and devices are properly plugged. Correct any problems that are found. c. Replace the SCSD cables and devices. d. If the problem persists: <ol style="list-style-type: none"> 1) Go to "Checkout procedure" on page 148. 2) Replace the system-board and chassis assembly, as described in "Replacing the Tier 2 system-board and chassis assembly" on page 229.

- Follow the suggested actions in the order in which they are listed in the Action column until the problem is solved. If an action solves the problem, then you can stop performing the remaining actions.
- See Chapter 3, "Parts listing," on page 197 to determine which components are CRUs and which components are FRUs.

Error code	Description	Action
BA120001	On an undetermined SCSD device, test unit ready failed; hardware error	<ol style="list-style-type: none"> 1. Troubleshoot the SCSD devices. 2. Verify that the SCSD cables and devices are properly plugged. Correct any problems that are found. 3. Replace the SCSD cables and devices. 4. If the problem persists: <ol style="list-style-type: none"> a. Go to "Checkout procedure" on page 148. b. Replace the system-board and chassis assembly, as described in "Replacing the Tier 2 system-board and chassis assembly" on page 229.
BA120002	On an undetermined SCSD device, test unit ready failed; sense data available	<ol style="list-style-type: none"> 1. Troubleshoot the SCSD devices. 2. Verify that the SCSD cables and devices are properly plugged. Correct any problems that are found. 3. Replace the SCSD cables and devices. 4. If the problem persists: <ol style="list-style-type: none"> a. Go to "Checkout procedure" on page 148. b. Replace the system-board and chassis assembly, as described in "Replacing the Tier 2 system-board and chassis assembly" on page 229.
BA120003	On an undetermined SCSD device, send diagnostic failed; sense data available	<ol style="list-style-type: none"> 1. Troubleshoot the SCSD devices. 2. Verify that the SCSD cables and devices are properly plugged. Correct any problems that are found. 3. Replace the SCSD cables and devices. 4. If the problem persists: <ol style="list-style-type: none"> a. Go to "Checkout procedure" on page 148. b. Replace the system-board and chassis assembly, as described in "Replacing the Tier 2 system-board and chassis assembly" on page 229.
BA120004	On an undetermined SCSD device, send diagnostic failed; devoffl command	<ol style="list-style-type: none"> 1. Troubleshoot the SCSD devices. 2. Verify that the SCSD cables and devices are properly plugged. Correct any problems that are found. 3. Replace the SCSD cables and devices. 4. If the problem persists: <ol style="list-style-type: none"> a. Go to "Checkout procedure" on page 148. b. Replace the system-board and chassis assembly, as described in "Replacing the Tier 2 system-board and chassis assembly" on page 229.
BA120010	Failed to generate the SAS device physical location code. The event log entry has the details.	<ol style="list-style-type: none"> 1. Reboot the blade server. 2. If the problem persists: <ol style="list-style-type: none"> a. Go to "Checkout procedure" on page 148. b. Replace the system-board and chassis assembly, as described in "Replacing the Tier 2 system-board and chassis assembly" on page 229.
BA130010	USB CD-ROM in the media tray: device remained busy longer than the time-out period	<ol style="list-style-type: none"> 1. Retry the operation. 2. Reboot the blade server. 3. Troubleshoot the media tray and CD-ROM drive. 4. Replace the USB CD or DVD drive. 5. If the problem persists: <ol style="list-style-type: none"> a. Go to "Checkout procedure" on page 148. b. Replace the system-board and chassis assembly, as described in "Replacing the Tier 2 system-board and chassis assembly" on page 229.

- Follow the suggested actions in the order in which they are listed in the Action column until the problem is solved. If an action solves the problem, then you can stop performing the remaining actions.
- See *Chapter 3, "Parts listing,"* on page 197 to determine which components are CRUs and which components are FRUs.

Error code	Description	Action
BA130011	USB CD-ROM in the media tray: execution of ATA/ATAPI command was not completed with the allowed time.	<ol style="list-style-type: none"> 1. Retry the operation. 2. Reboot the blade server. 3. Troubleshoot the media tray and CD-ROM drive. 4. Replace the USB CD or DVD drive. 5. If the problem persists: <ol style="list-style-type: none"> a. Go to "<i>Checkout procedure</i>" on page 148. b. Replace the system-board and chassis assembly, as described in "<i>Replacing the Tier 2 system-board and chassis assembly</i>" on page 229.
BA130012	USB CD-ROM in the media tray: execution of ATA/ATAPI command failed.	<ol style="list-style-type: none"> 1. Retry the operation. 2. Reboot the blade server. 3. Troubleshoot the media tray and CD-ROM drive. 4. Replace the USB CD or DVD drive. 5. If the problem persists: <ol style="list-style-type: none"> a. Go to "<i>Checkout procedure</i>" on page 148. b. Replace the system-board and chassis assembly, as described in "<i>Replacing the Tier 2 system-board and chassis assembly</i>" on page 229.
BA130013	USB CD-ROM in the media tray: bootable media is missing from the drive	<ol style="list-style-type: none"> 1. Insert a bootable CD in the drive and retry the operation. 2. If the problem persists: <ol style="list-style-type: none"> a. Retry the operation. b. Reboot the blade server. c. Troubleshoot the media tray and CD-ROM drive. d. Replace the USB CD or DVD drive. e. If the problem persists: <ol style="list-style-type: none"> 1) Go to "<i>Checkout procedure</i>" on page 148. 2) Replace the system-board and chassis assembly, as described in "<i>Replacing the Tier 2 system-board and chassis assembly</i>" on page 229.
BA130014	USB CD-ROM in the media tray: the media in the USB CD-ROM drive has been changed.	<ol style="list-style-type: none"> 1. Retry the operation. 2. Reboot the blade server. 3. Troubleshoot the media tray and CD-ROM drive. 4. Replace the USB CD or DVD drive. 5. If the problem persists: <ol style="list-style-type: none"> a. Go to "<i>Checkout procedure</i>" on page 148. b. Replace the system-board and chassis assembly, as described in "<i>Replacing the Tier 2 system-board and chassis assembly</i>" on page 229.
BA130015	USB CD-ROM in the media tray: ATA/ATAPI packet command execution failed.	<ol style="list-style-type: none"> 1. Remove the CD or DVD in the drive and replace it with a known-good disk. 2. If the problem persists: <ol style="list-style-type: none"> a. Retry the operation. b. Reboot the blade server. c. Troubleshoot the media tray and CD-ROM drive. d. Replace the USB CD or DVD drive. e. If the problem persists: <ol style="list-style-type: none"> 1) Go to "<i>Checkout procedure</i>" on page 148. 2) Replace the system-board and chassis assembly, as described in "<i>Replacing the Tier 2 system-board and chassis assembly</i>" on page 229.

- Follow the suggested actions in the order in which they are listed in the Action column until the problem is solved. If an action solves the problem, then you can stop performing the remaining actions.
- See Chapter 3, "Parts listing," on page 197 to determine which components are CRUs and which components are FRUs.

Error code	Description	Action
BA131010	The USB keyboard has been removed.	<ol style="list-style-type: none"> 1. Reseat the keyboard cable in the management module USB port. 2. Check for server firmware updates; then, install the updates if available.
BA140001	The SCSD read/write optical test unit ready failed; hardware error.	<ol style="list-style-type: none"> 1. Troubleshoot the SCSD devices. 2. Verify that the SCSD cables and devices are properly plugged. Correct any problems that are found. 3. Replace the SCSD cables and devices. 4. If the problem persists: <ol style="list-style-type: none"> a. Go to "Checkout procedure" on page 148. b. Replace the system-board and chassis assembly, as described in "Replacing the Tier 2 system-board and chassis assembly" on page 229.
BA140002	The SCSD read/write optical test unit ready failed; sense data available.	<ol style="list-style-type: none"> 1. Troubleshoot the SCSD devices. 2. Verify that the SCSD cables and devices are properly plugged. Correct any problems that are found. 3. Replace the SCSD cables and devices. 4. If the problem persists: <ol style="list-style-type: none"> a. Go to "Checkout procedure" on page 148. b. Replace the system-board and chassis assembly, as described in "Replacing the Tier 2 system-board and chassis assembly" on page 229.
BA140003	The SCSD read/write optical send diagnostic failed; sense data available.	<ol style="list-style-type: none"> 1. Troubleshoot the SCSD devices. 2. Verify that the SCSD cables and devices are properly plugged. Correct any problems that are found. 3. Replace the SCSD cables and devices. 4. If the problem persists: <ol style="list-style-type: none"> a. Go to "Checkout procedure" on page 148. b. Replace the system-board and chassis assembly, as described in "Replacing the Tier 2 system-board and chassis assembly" on page 229.
BA140004	The SCSD read/write optical send diagnostic failed; devoff command.	<ol style="list-style-type: none"> 1. Troubleshoot the SCSD devices. 2. Verify that the SCSD cables and devices are properly plugged. Correct any problems that are found. 3. Replace the SCSD cables and devices. 4. If the problem persists: <ol style="list-style-type: none"> a. Go to "Checkout procedure" on page 148. b. Replace the system-board and chassis assembly, as described in "Replacing the Tier 2 system-board and chassis assembly" on page 229.
BA150001	PCI Ethernet BNC/RJ-45 or PCI Ethernet AUI/RJ-45 adapter: internal wrap test failure	Replace the adapter specified by the location code.
BA151001	10/100 Mbps Ethernet PCI adapter: internal wrap test failure	Replace the adapter specified by the location code.
BA151002	10/100 Mbps Ethernet card failure	<ol style="list-style-type: none"> 1. Go to "Checkout procedure" on page 148. 2. Replace the system-board and chassis assembly, as described in "Replacing the Tier 2 system-board and chassis assembly" on page 229.
BA153002	Gigabit Ethernet adapter failure	Verify that the MAC address programmed in the FLASH/EEPROM is correct.

- Follow the suggested actions in the order in which they are listed in the Action column until the problem is solved. If an action solves the problem, then you can stop performing the remaining actions.
- See *Chapter 3, "Parts listing,"* on page 197 to determine which components are CRUs and which components are FRUs.

Error code	Description	Action
BA153003	Gigabit Ethernet adapter failure	<ol style="list-style-type: none"> 1. Check for server firmware updates; then, install the updates if available. 2. Replace the Gigabit Ethernet adapter.
BA154010	HEA software error	<ol style="list-style-type: none"> 1. Go to "Checkout procedure" on page 148. 2. Replace the system-board and chassis assembly, as described in "Replacing the Tier 2 system-board and chassis assembly" on page 229.
BA154020	The required open firmware property was not found.	<ol style="list-style-type: none"> 1. Reboot the blade server. 2. If the problem persists: <ol style="list-style-type: none"> a. Go to "Checkout procedure" on page 148. b. Replace the system-board and chassis assembly, as described in "Replacing the Tier 2 system-board and chassis assembly" on page 229.
BA154030	Invalid parameters were passed to the HEA device driver.	<ol style="list-style-type: none"> 1. Reboot the blade server. 2. If the problem persists: <ol style="list-style-type: none"> a. Go to "Checkout procedure" on page 148. b. Replace the system-board and chassis assembly, as described in "Replacing the Tier 2 system-board and chassis assembly" on page 229.
BA154040	The TFTP package open failed	<ol style="list-style-type: none"> 1. Reboot the blade server. 2. If the problem persists: <ol style="list-style-type: none"> a. Go to "Checkout procedure" on page 148. b. Replace the system-board and chassis assembly, as described in "Replacing the Tier 2 system-board and chassis assembly" on page 229.
BA154050	The transmit operation failed.	<ol style="list-style-type: none"> 1. Reboot the blade server. 2. If the problem persists: <ol style="list-style-type: none"> a. Go to "Checkout procedure" on page 148. b. Replace the system-board and chassis assembly, as described in "Replacing the Tier 2 system-board and chassis assembly" on page 229.
BA154060	Failed to initialize the HEA port or queue	<ol style="list-style-type: none"> 1. Reboot the blade server. 2. If the problem persists: <ol style="list-style-type: none"> a. Go to "Checkout procedure" on page 148. b. Replace the system-board and chassis assembly, as described in "Replacing the Tier 2 system-board and chassis assembly" on page 229.
BA154070	The receive operation failed.	<ol style="list-style-type: none"> 1. Reboot the blade server. 2. If the problem persists: <ol style="list-style-type: none"> a. Go to "Checkout procedure" on page 148. b. Replace the system-board and chassis assembly, as described in "Replacing the Tier 2 system-board and chassis assembly" on page 229.
BA170000	NVRAMRC initialization failed; device test failed	<ol style="list-style-type: none"> 1. Go to "Checkout procedure" on page 148. 2. Replace the system-board and chassis assembly, as described in "Replacing the Tier 2 system-board and chassis assembly" on page 229.
BA170100	NVRAM data validation check failed	<ol style="list-style-type: none"> 1. Shut down the blade server; then, restart it. 2. If the problem persists: <ol style="list-style-type: none"> a. Go to "Checkout procedure" on page 148. b. Replace the system-board and chassis assembly, as described in "Replacing the Tier 2 system-board and chassis assembly" on page 229.

- Follow the suggested actions in the order in which they are listed in the Action column until the problem is solved. If an action solves the problem, then you can stop performing the remaining actions.
- See Chapter 3, "Parts listing," on page 197 to determine which components are CRUs and which components are FRUs.

Error code	Description	Action
BA170201	The firmware was unable to expand target partition - saving configuration variable	<ol style="list-style-type: none"> 1. Reboot the blade server. 2. If the problem persists: <ol style="list-style-type: none"> a. Go to "Checkout procedure" on page 148. b. Replace the system-board and chassis assembly, as described in "Replacing the Tier 2 system-board and chassis assembly" on page 229.
BA170202	The firmware was unable to expand target partition - writing event log entry	<ol style="list-style-type: none"> 1. Reboot the blade server. 2. If the problem persists: <ol style="list-style-type: none"> a. Go to "Checkout procedure" on page 148. b. Replace the system-board and chassis assembly, as described in "Replacing the Tier 2 system-board and chassis assembly" on page 229.
BA170203	The firmware was unable to expand target partition - writing VPD data	<ol style="list-style-type: none"> 1. Reboot the blade server. 2. If the problem persists: <ol style="list-style-type: none"> a. Go to "Checkout procedure" on page 148. b. Replace the system-board and chassis assembly, as described in "Replacing the Tier 2 system-board and chassis assembly" on page 229.
BA170210	Setenv/\$Setenv parameter error - name contains a null character	<ol style="list-style-type: none"> 1. Go to "Checkout procedure" on page 148. 2. Replace the system-board and chassis assembly, as described in "Replacing the Tier 2 system-board and chassis assembly" on page 229.
BA170211	Setenv/\$Setenv parameter error - value contains a null character	<ol style="list-style-type: none"> 1. Go to "Checkout procedure" on page 148. 2. Replace the system-board and chassis assembly, as described in "Replacing the Tier 2 system-board and chassis assembly" on page 229.
BA170220	Unable to write a variable value to NVRAM due to lack of free memory in NVRAM.	<ol style="list-style-type: none"> 1. Reduce the number of partitions, if possible, to add more NVRAM memory to this partition. 2. If the problem persists: <ol style="list-style-type: none"> a. Go to "Checkout procedure" on page 148. b. Replace the system-board and chassis assembly, as described in "Replacing the Tier 2 system-board and chassis assembly" on page 229.
BA170221	Setenv/\$setenv had to delete stored firmware network boot settings to free memory in NVRAM.	Enter the adapter and network parameters again for the network boot or network installation.
BA170998	NVRAMRC script evaluation error - command line execution error.	<ol style="list-style-type: none"> 1. Go to "Checkout procedure" on page 148. 2. Replace the system-board and chassis assembly, as described in "Replacing the Tier 2 system-board and chassis assembly" on page 258.
BA180008	PCI device Fcode evaluation error	<ol style="list-style-type: none"> 1. Go to "Checkout procedure" on page 148. 2. Replace the system-board and chassis assembly, as described in "Replacing the Tier 2 system-board and chassis assembly" on page 229.

- Follow the suggested actions in the order in which they are listed in the Action column until the problem is solved. If an action solves the problem, then you can stop performing the remaining actions.
- See *Chapter 3, "Parts listing,"* on page 197 to determine which components are CRUs and which components are FRUs.

Error code	Description	Action
BA180009	The Fcode on a PCI adapter left a data stack imbalance	<ol style="list-style-type: none"> 1. Reseat the PCI adapter card. 2. Check for adapter firmware updates; then, install the updates if available. 3. Check for server firmware updates; then, install the updates if available. 4. Replace the PCI adapter card. 5. If the problem persists: <ol style="list-style-type: none"> a. Go to "Checkout procedure" on page 148. b. Replace the system-board and chassis assembly, as described in "Replacing the Tier 2 system-board and chassis assembly" on page 229.
BA180010	PCI probe error, bridge in freeze state	<ol style="list-style-type: none"> 1. Go to "Checkout procedure" on page 148. 2. Replace the system-board and chassis assembly, as described in "Replacing the Tier 2 system-board and chassis assembly" on page 229.
BA180011	PCI bridge probe error, bridge is not usable	<ol style="list-style-type: none"> 1. Go to "Checkout procedure" on page 148. 2. Replace the system-board and chassis assembly, as described in "Replacing the Tier 2 system-board and chassis assembly" on page 258.
BA180012	PCI device runtime error, bridge in freeze state	<ol style="list-style-type: none"> 1. Go to "Checkout procedure" on page 148. 2. Replace the system-board and chassis assembly, as described in "Replacing the Tier 2 system-board and chassis assembly" on page 258.
BA180014	MSI software error	<ol style="list-style-type: none"> 1. Reboot the blade server. 2. If the problem persists: <ol style="list-style-type: none"> a. Go to "Checkout procedure" on page 148. b. Replace the system-board and chassis assembly, as described in "Replacing the Tier 2 system-board and chassis assembly" on page 229.
BA180020	No response was received from a slot during PCI probing.	<ol style="list-style-type: none"> 1. Reboot the blade server. 2. If the problem persists: <ol style="list-style-type: none"> a. Go to "Checkout procedure" on page 148. b. Replace the system-board and chassis assembly, as described in "Replacing the Tier 2 system-board and chassis assembly" on page 229.
BA180099	PCI probe error; bridge in freeze state, slot in reset state	<ol style="list-style-type: none"> 1. Reseat the PCI adapter card. 2. Check for adapter firmware updates; then, install the updates if available. 3. Check for server firmware updates; then, install the updates if available. 4. Replace the PCI adapter card. 5. If the problem persists: <ol style="list-style-type: none"> a. Go to "Checkout procedure" on page 148. b. Replace the system-board and chassis assembly, as described in "Replacing the Tier 2 system-board and chassis assembly" on page 229.
BA180100	The FDDI adapter Fcode driver is not supported on this server.	Bull may produce a compatible driver in the future, but does not guarantee one.
BA180101	Stack underflow from fibre-channel adapter	<ol style="list-style-type: none"> 1. Go to "Checkout procedure" on page 148. 2. Replace the system-board and chassis assembly, as described in "Replacing the Tier 2 system-board and chassis assembly" on page 229.

- Follow the suggested actions in the order in which they are listed in the Action column until the problem is solved. If an action solves the problem, then you can stop performing the remaining actions.
- See Chapter 3, "Parts listing," on page 197 to determine which components are CRUs and which components are FRUs.

Error code	Description	Action
BA190001	Firmware function to get/set time-of-day reported an error	<ol style="list-style-type: none"> 1. Go to "Checkout procedure" on page 148. 2. Replace the system-board and chassis assembly, as described in "Replacing the Tier 2 system-board and chassis assembly" on page 229.
BA201001	The serial interface dropped data packets	<ol style="list-style-type: none"> 1. Go to "Checkout procedure" on page 148. 2. Replace the system-board and chassis assembly, as described in "Replacing the Tier 2 system-board and chassis assembly" on page 229.
BA201002	The serial interface failed to open	<ol style="list-style-type: none"> 1. Go to "Checkout procedure" on page 148. 2. Replace the system-board and chassis assembly, as described in "Replacing the Tier 2 system-board and chassis assembly" on page 229.
BA201003	The firmware failed to handshake properly with the serial interface	<ol style="list-style-type: none"> 1. Reboot the blade server. 2. If the problem persists: <ol style="list-style-type: none"> a. Go to "Checkout procedure" on page 148. b. Replace the system-board and chassis assembly, as described in "Replacing the Tier 2 system-board and chassis assembly" on page 229.
BA210000	Partition firmware reports a default catch	<ol style="list-style-type: none"> 1. Reboot the blade server. 2. If the problem persists: <ol style="list-style-type: none"> a. Go to "Checkout procedure" on page 148. b. Replace the system-board and chassis assembly, as described in "Replacing the Tier 2 system-board and chassis assembly" on page 229.
BA210001	Partition firmware reports a stack underflow was caught	<ol style="list-style-type: none"> 1. Reboot the blade server. 2. If the problem persists: <ol style="list-style-type: none"> a. Go to "Checkout procedure" on page 148. b. Replace the system-board and chassis assembly, as described in "Replacing the Tier 2 system-board and chassis assembly" on page 229.
BA210002	Partition firmware was ready before standout was ready	<ol style="list-style-type: none"> 1. Reboot the blade server. 2. If the problem persists: <ol style="list-style-type: none"> a. Go to "Checkout procedure" on page 148. b. Replace the system-board and chassis assembly, as described in "Replacing the Tier 2 system-board and chassis assembly" on page 229.
BA210003	A data storage error was caught by partition firmware	<ol style="list-style-type: none"> 1. If the location code reported with the error points to an adapter, check for adapter firmware updates. 2. Apply any available updates. 3. Check for server firmware updates. 4. Apply any available updates. 5. If the problem persists: <ol style="list-style-type: none"> a. Go to "Checkout procedure" on page 148. b. Replace the system-board and chassis assembly, as described in "Replacing the Tier 2 system-board and chassis assembly" on page 229.
BA210004	An open firmware stack-depth assert failed.	<ol style="list-style-type: none"> 1. Reboot the blade server. 2. If the problem persists: <ol style="list-style-type: none"> a. Go to "Checkout procedure" on page 148. b. Replace the system-board and chassis assembly, as described in "Replacing the Tier 2 system-board and chassis assembly" on page 229.

- Follow the suggested actions in the order in which they are listed in the Action column until the problem is solved. If an action solves the problem, then you can stop performing the remaining actions.
- See *Chapter 3, "Parts listing,"* on page 197 to determine which components are CRUs and which components are FRUs.

Error code	Description	Action
BA210010	The transfer of control to the SLIC loader failed	<ol style="list-style-type: none"> 1. Go to "Checkout procedure" on page 148. 2. Replace the system-board and chassis assembly, as described in "Replacing the Tier 2 system-board and chassis assembly" on page 229.
BA210011	The transfer of control to the IO Reporter failed	<ol style="list-style-type: none"> 1. Go to "Checkout procedure" on page 148. 2. Replace the system-board and chassis assembly, as described in "Replacing the Tier 2 system-board and chassis assembly" on page 229.
BA210012	There was an NVRAMRC forced-boot problem; unable to load the previous boot's operating system image	<ol style="list-style-type: none"> 1. Use the SMS menus to verify that the partition firmware can still detect the operating system image. 2. If the problem persists: <ol style="list-style-type: none"> a. Go to "Checkout procedure" on page 148. b. Replace the system-board and chassis assembly, as described in "Replacing the Tier 2 system-board and chassis assembly" on page 229.
BA210013	There was a partition firmware error when in the SMS menus.	<ol style="list-style-type: none"> 1. Reboot the blade server. 2. If the problem persists: <ol style="list-style-type: none"> a. Go to "Checkout procedure" on page 148. b. Replace the system-board and chassis assembly, as described in "Replacing the Tier 2 system-board and chassis assembly" on page 229.
BA210020	I/O configuration exceeded the maximum size allowed by partition firmware.	<ol style="list-style-type: none"> 1. Increase the logical memory block size to 256 MB and restart the blade server. 2. If the problem persists: <ol style="list-style-type: none"> a. Go to "Checkout procedure" on page 148. b. Replace the system-board and chassis assembly, as described in "Replacing the Tier 2 system-board and chassis assembly" on page 229.
BA210100	An error may not have been sent to the management module event log.	<ol style="list-style-type: none"> 1. Reboot the blade server. 2. If the problem persists: <ol style="list-style-type: none"> a. Go to "Checkout procedure" on page 148. b. Replace the system-board and chassis assembly, as described in "Replacing the Tier 2 system-board and chassis assembly" on page 229.
BA210101	The partition firmware event log queue is full	<ol style="list-style-type: none"> 1. Reboot the blade server. 2. If the problem persists: <ol style="list-style-type: none"> a. Go to "Checkout procedure" on page 148. b. Replace the system-board and chassis assembly, as described in "Replacing the Tier 2 system-board and chassis assembly" on page 229.
BA210102	There was a communication failure between partition firmware and the hypervisor. The lpevent that was expected from the hypervisor was not received.	<ol style="list-style-type: none"> 1. Review the event log for errors that occurred around the time of this error. 2. Correct any errors that are found and reboot the blade server. 3. If the problem persists: <ol style="list-style-type: none"> a. Reboot the blade server. b. If the problem persists: <ol style="list-style-type: none"> 1) Go to "Checkout procedure" on page 148. 2) Replace the system-board and chassis assembly, as described in "Replacing the Tier 2 system-board and chassis assembly" on page 229.

- Follow the suggested actions in the order in which they are listed in the Action column until the problem is solved. If an action solves the problem, then you can stop performing the remaining actions.
- See Chapter 3, "Parts listing," on page 197 to determine which components are CRUs and which components are FRUs.

Error code	Description	Action
BA210103	There was a communication failure between partition firmware and the hypervisor. There was a failing return code with the lpevent acknowledgement from the hypervisor.	<ol style="list-style-type: none"> 1. Review the event log for errors that occurred around the time of this error. 2. Correct any errors that are found and reboot the blade server. 3. If the problem persists: <ol style="list-style-type: none"> a. Reboot the blade server. b. If the problem persists: <ol style="list-style-type: none"> 1) Go to "Checkout procedure" on page 148. 2) Replace the system-board and chassis assembly, as described in "Replacing the Tier 2 system-board and chassis assembly" on page 229.
BA220010	There was a partition firmware error during a USB hotplug probing. USB hotplug may not work properly on this partition.	<ol style="list-style-type: none"> 1. Look for EEH-related errors in the event log. 2. Resolve any EEH event log entries that are found. 3. Correct any errors that are found and reboot the blade server. 4. If the problem persists: <ol style="list-style-type: none"> a. Go to "Checkout procedure" on page 148. b. Replace the system-board and chassis assembly, as described in "Replacing the Tier 2 system-board and chassis assembly" on page 229.
BA220020	CRQ registration error; partner vslot may not be valid	Verify that this client virtual slot device has a valid server virtual slot device in a hosting partition.
BA278001	Failed to flash firmware: invalid image file	Download a new firmware update image and retry the update.
BA278002	Flash file is not designed for this platform	Download a new firmware update image and retry the update.
BA278003	Unable to lock the firmware update lid manager	<ol style="list-style-type: none"> 1. Restart the blade server. 2. Verify that the operating system is authorized to update the firmware. If the system is running multiple partitions, verify that this partition has service authority.
BA278004	An invalid firmware update lid was requested	Download a new firmware update image and retry the update.
BA278005	Failed to flash a firmware update lid	Download a new firmware update image and retry the update.
BA278006	Unable to unlock the firmware update lid manager	Restart the blade server.
BA278007	Failed to reboot the system after a firmware flash update	Restart the blade server.
BA278009	The operating system's server firmware update management tools are incompatible with this system.	Go to the download site at www14.software.ibm.com/webapp/set2/sas/f/lopdiags/home.html to download the latest version of the service aids package for Linux.
BA27800A	The firmware installation failed due to a hardware error that was reported.	<ol style="list-style-type: none"> 1. Look for hardware errors in the event log. 2. Resolve any hardware errors that are found. 3. If the problem persists: <ol style="list-style-type: none"> a. Go to "Checkout procedure" on page 148. b. Replace the system-board and chassis assembly, as described in "Replacing the Tier 2 system-board and chassis assembly" on page 229.

- Follow the suggested actions in the order in which they are listed in the Action column until the problem is solved. If an action solves the problem, then you can stop performing the remaining actions.
- See *Chapter 3, "Parts listing,"* on page 197 to determine which components are CRUs and which components are FRUs.

Error code	Description	Action
BA280000	RTAS discovered an invalid operation that may cause a hardware error	<ol style="list-style-type: none"> 1. Go to "Checkout procedure" on page 148. 2. Replace the system-board and chassis assembly, as described in "Replacing the Tier 2 system-board and chassis assembly" on page 229.
BA290000	RTAS discovered an internal stack overflow	<ol style="list-style-type: none"> 1. Go to "Checkout procedure" on page 148. 2. Replace the system-board and chassis assembly, as described in "Replacing the Tier 2 system-board and chassis assembly" on page 229.
BA290001	RTAS low memory corruption was detected	<ol style="list-style-type: none"> 1. Reboot the blade server. 2. If the problem persists: <ol style="list-style-type: none"> a. Go to "Checkout procedure" on page 148. b. Replace the system-board and chassis assembly, as described in "Replacing the Tier 2 system-board and chassis assembly" on page 229.
BA290002	RTAS low memory corruption was detected	<ol style="list-style-type: none"> 1. Reboot the blade server. 2. If the problem persists: <ol style="list-style-type: none"> a. Go to "Checkout procedure" on page 148. b. Replace the system-board and chassis assembly, as described in "Replacing the Tier 2 system-board and chassis assembly" on page 229.
BA310010	Unable to obtain the SRC history	<ol style="list-style-type: none"> 1. Reboot the blade server. 2. If the problem persists: <ol style="list-style-type: none"> a. Go to "Checkout procedure" on page 148. b. Replace the system-board and chassis assembly, as described in "Replacing the Tier 2 system-board and chassis assembly" on page 229.
BA310020	An invalid SRC history was obtained.	<ol style="list-style-type: none"> 1. Reboot the blade server. 2. If the problem persists: <ol style="list-style-type: none"> a. Go to "Checkout procedure" on page 148. b. Replace the system-board and chassis assembly, as described in "Replacing the Tier 2 system-board and chassis assembly" on page 229.
BA310030	Writing the MAC address to the VPD failed.	<ol style="list-style-type: none"> 1. Reboot the blade server. 2. If the problem persists: <ol style="list-style-type: none"> a. Go to "Checkout procedure" on page 148. b. Replace the system-board and chassis assembly, as described in "Replacing the Tier 2 system-board and chassis assembly" on page 229.
BA330000	Memory allocation error.	<ol style="list-style-type: none"> 1. Reboot the blade server. 2. If the problem persists: <ol style="list-style-type: none"> a. Go to "Checkout procedure" on page 148. b. Replace the system-board and chassis assembly, as described in "Replacing the Tier 2 system-board and chassis assembly" on page 229.
BA330001	Memory allocation error.	<ol style="list-style-type: none"> 1. Reboot the blade server. 2. If the problem persists: <ol style="list-style-type: none"> a. Go to "Checkout procedure" on page 148. b. Replace the system-board and chassis assembly, as described in "Replacing the Tier 2 system-board and chassis assembly" on page 229.

- Follow the suggested actions in the order in which they are listed in the Action column until the problem is solved. If an action solves the problem, then you can stop performing the remaining actions.
- See Chapter 3, "Parts listing," on page 197 to determine which components are CRUs and which components are FRUs.

Error code	Description	Action
BA330002	Memory allocation error.	<ol style="list-style-type: none"> 1. Reboot the blade server. 2. If the problem persists: <ol style="list-style-type: none"> a. Go to "Checkout procedure" on page 148. b. Replace the system-board and chassis assembly, as described in "Replacing the Tier 2 system-board and chassis assembly" on page 229.
BA330003	Memory allocation error.	<ol style="list-style-type: none"> 1. Reboot the blade server. 2. If the problem persists: <ol style="list-style-type: none"> a. Go to "Checkout procedure" on page 148. b. Replace the system-board and chassis assembly, as described in "Replacing the Tier 2 system-board and chassis assembly" on page 229.
BA330004	Memory allocation error.	<ol style="list-style-type: none"> 1. Reboot the blade server. 2. If the problem persists: <ol style="list-style-type: none"> a. Go to "Checkout procedure" on page 148. b. Replace the system-board and chassis assembly, as described in "Replacing the Tier 2 system-board and chassis assembly" on page 229.
BA340001	There was a logical partition event communication failure reading the open fabric manager parameter data structure from the service processor.	<ol style="list-style-type: none"> 1. Reboot the blade server. 2. If the problem persists: <ol style="list-style-type: none"> a. Go to "Checkout procedure" on page 148. b. Replace the system-board and chassis assembly, as described in "Replacing the Tier 2 system-board and chassis assembly" on page 229.
BA340002	There was a logical partition event communication failure reading the open fabric manager location code mapping data from the service processor.	<ol style="list-style-type: none"> 1. Reboot the blade server. 2. If the problem persists: <ol style="list-style-type: none"> a. Go to "Checkout procedure" on page 148. b. Replace the system-board and chassis assembly, as described in "Replacing the Tier 2 system-board and chassis assembly" on page 229.
BA340003	An internal firmware error occurred; unable to allocate memory for the open fabric manager location code mapping data.	<ol style="list-style-type: none"> 1. Reboot the blade server. 2. If the problem persists: <ol style="list-style-type: none"> a. Go to "Checkout procedure" on page 148. b. Replace the system-board and chassis assembly, as described in "Replacing the Tier 2 system-board and chassis assembly" on page 229.
BA340004	An internal firmware error occurred; the open fabric manager parameter data was corrupted.	<ol style="list-style-type: none"> 1. Reboot the blade server. 2. If the problem persists: <ol style="list-style-type: none"> a. Go to "Checkout procedure" on page 148. b. Replace the system-board and chassis assembly, as described in "Replacing the Tier 2 system-board and chassis assembly" on page 229.
BA340005	An internal firmware error occurred; the location code mapping table was corrupted.	<ol style="list-style-type: none"> 1. Reboot the blade server. 2. If the problem persists: <ol style="list-style-type: none"> a. Go to "Checkout procedure" on page 148. b. Replace the system-board and chassis assembly, as described in "Replacing the Tier 2 system-board and chassis assembly" on page 229.

- Follow the suggested actions in the order in which they are listed in the Action column until the problem is solved. If an action solves the problem, then you can stop performing the remaining actions.
- See *Chapter 3, "Parts listing,"* on page 197 to determine which components are CRUs and which components are FRUs.

Error code	Description	Action
BA340006	An LP event communication failure occurred reading the system initiator capability data from the service processor.	<ol style="list-style-type: none"> 1. Reboot the blade server. 2. If the problem persists: <ol style="list-style-type: none"> a. Go to "Checkout procedure" on page 148. b. Replace the system-board and chassis assembly, as described in "Replacing the Tier 2 system-board and chassis assembly" on page 229.
BA340007	An internal firmware error occurred; the open fabric manager system initiator capability was corrupted.	<ol style="list-style-type: none"> 1. Reboot the blade server. 2. If the problem persists: <ol style="list-style-type: none"> a. Go to "Checkout procedure" on page 148. b. Replace the system-board and chassis assembly, as described in "Replacing the Tier 2 system-board and chassis assembly" on page 229.
BA340008	An internal firmware error occurred; the open fabric manager system initiator capability data version was not correct.	<ol style="list-style-type: none"> 1. Reboot the blade server. 2. If the problem persists: <ol style="list-style-type: none"> a. Go to "Checkout procedure" on page 148. b. Replace the system-board and chassis assembly, as described in "Replacing the Tier 2 system-board and chassis assembly" on page 229.
BA340009	An internal firmware error occurred; the open fabric manager system initiator capability processing encountered an unexpected error.	<ol style="list-style-type: none"> 1. Reboot the blade server. 2. If the problem persists: <ol style="list-style-type: none"> a. Go to "Checkout procedure" on page 148. b. Replace the system-board and chassis assembly, as described in "Replacing the Tier 2 system-board and chassis assembly" on page 229.
BA340010	An internal firmware error was detected during open fabric manager processing.	<ol style="list-style-type: none"> 1. Reboot the blade server. 2. If the problem persists: <ol style="list-style-type: none"> a. Go to "Checkout procedure" on page 148. b. Replace the system-board and chassis assembly, as described in "Replacing the Tier 2 system-board and chassis assembly" on page 229.
BA340011	Assignment of fabric ID to the I/O adapter failed.	<ol style="list-style-type: none"> 1. Reboot the blade server. 2. If the problem persists: <ol style="list-style-type: none"> a. Go to "Checkout procedure" on page 148. b. Replace the system-board and chassis assembly, as described in "Replacing the Tier 2 system-board and chassis assembly" on page 229.
BA340020	A logical partition event communication failure occurred when writing the open fabric manager parameter data to the service processor.	<ol style="list-style-type: none"> 1. Reboot the blade server. 2. If the problem persists: <ol style="list-style-type: none"> a. Go to "Checkout procedure" on page 148. b. Replace the system-board and chassis assembly, as described in "Replacing the Tier 2 system-board and chassis assembly" on page 229.
BA340021	A logical partition event communication failure occurred when writing the open fabric manager system initiator capabilities data to the service processor.	<ol style="list-style-type: none"> 1. Reboot the blade server. 2. If the problem persists: <ol style="list-style-type: none"> a. Go to "Checkout procedure" on page 148. b. Replace the system-board and chassis assembly, as described in "Replacing the Tier 2 system-board and chassis assembly" on page 229.

- Follow the suggested actions in the order in which they are listed in the Action column until the problem is solved. If an action solves the problem, then you can stop performing the remaining actions.
- See *Chapter 3, "Parts listing,"* on page 197 to determine which components are CRUs and which components are FRUs.

Error code	Description	Action
BA400001	Informational message: DMA trace buffer full.	1. Reboot the blade server. 2. If the problem persists: <ol style="list-style-type: none"> Go to "<i>Checkout procedure</i>" on page 148. Replace the system-board and chassis assembly, as described in "<i>Replacing the Tier 2 system-board and chassis assembly</i>" on page 229.
BA400002	Informational message: DMA map-out size mismatch.	1. Reboot the blade server. 2. If the problem persists: <ol style="list-style-type: none"> Go to "<i>Checkout procedure</i>" on page 148. Replace the system-board and chassis assembly, as described in "<i>Replacing the Tier 2 system-board and chassis assembly</i>" on page 229.

2.4.2 POST progress codes (checkpoints)

When you turn on the blade server, the power-on self-test (POST) performs a series of tests to check the operation of the blade server components. Use the management module to view progress codes that offer information about the stages involved in powering on and performing an initial program load (IPL).

Progress codes do not indicate an error, although in some cases, the blade server can pause indefinitely (hang). Progress codes for blade servers are 9-word, 8-digit hexadecimal numbers that start with C and D.

Checkpoints are generated by various components. The baseboard management controller (BMC) service processor and the partitioning firmware are key contributors. The service processor provides additional isolation procedure codes for troubleshooting.

A checkpoint might have an associated location code as part of the message. The location code provides information that identifies the failing component when there is a hang condition.

-
- Notes**
- For checkpoints with no associated location code, see *“Light path diagnostics”* on page 182 to identify the failing component when there is a hang condition.
 - For checkpoints with location codes, see *“Location codes”* on page 18 to identify the failing component when there is a hang condition.
 - For eight-digit codes not listed here, see *“Checkout procedure”* on page 148 for information.
-

The management module can display the most recent 32 SRCs and time stamps. Manually refresh the list to update it.

Select **Blade Service Data** → *blade_name* in the management module to see a list of the 32 most recent SRCs.

Table 2-14. Management module reference code listing

Unique ID	System Reference Code	Timestamp
00040001	D1513901	2005-11-13 19:30:20
00000016	D1513801	2005-11-13 19:30:16

Any message with more detail is highlighted as a link in the System Reference Code column. Click the message to cause the management module to present the additional message detail:

D1513901

Created at: 2007-11-13 19:30:20

SRC Version: 0x02

Hex Words 2-5: 020110F0 52298910 C1472000 200000FF

2.4.2.1

C1001F00 to C1645300 Service processor checkpoints

The C1xx progress codes, or checkpoints, offer information about the initialization of both the service processor and the server. Service processor checkpoints are typical reference codes that occur during the initial program load (IPL) of the server.

Table 15 lists the progress codes that might be displayed during the power-on self-test (POST), along with suggested actions to take if the system hangs on the progress code. Only when you experience a hang condition should you take any of the actions described for a progress code.

In the following progress codes, x can be any number or letter.

Table 2-15. C1001F00 to C1645300 checkpoints

Progress code	Description	Action
<ul style="list-style-type: none"> If the system hangs on a progress code, follow the suggested actions in the order in which they are listed in the Action column until the problem is solved. If an action solves the problem, you can stop performing these remaining actions. See Chapter 3, "Parts listing," on page 197 to determine which components are CRUs and which components are FRUs. 		
C10010xx	Pre-standby	<ol style="list-style-type: none"> Go to "Checkout procedure" on page 148. Replace the system-board and chassis assembly, as described in "Replacing the Tier 2 system-board and chassis assembly" on page 229.
C1001F00	Pre-standby: starting initial transition file	<ol style="list-style-type: none"> Go to "Checkout procedure" on page 148. Replace the system-board and chassis assembly, as described in "Replacing the Tier 2 system-board and chassis assembly" on page 258.
C1001F0D	Pre-standby: discovery completed in initial transition file While the blade server displays this checkpoint, the service processor reads the system vital product data (VPD). The service processor must complete reading the system VPD before the system displays the next progress code.	<ol style="list-style-type: none"> Wait at least 15 minutes for this checkpoint to change before you decide that the system is hung. Reading the system VPD might take as long as 15 minutes on systems with maximum configurations or many disk drives. Go to "Checkout procedure" on page 148. Replace the system-board and chassis assembly, as described in "Replacing the Tier 2 system-board and chassis assembly" on page 229.
C1001F0F	Pre-standby: waiting for standby synchronization from initial transition file	<ol style="list-style-type: none"> Go to "Checkout procedure" on page 148. Replace the system-board and chassis assembly, as described in "Replacing the Tier 2 system-board and chassis assembly" on page 229.
C1001FFF	Pre-standby: completed initial transition file	<ol style="list-style-type: none"> Go to "Checkout procedure" on page 148. Replace the system-board and chassis assembly, as described in "Replacing the Tier 2 system-board and chassis assembly" on page 229.
C1009x01	Hardware object manager: (HOM): the cancontinue flag is being cleared	<ol style="list-style-type: none"> Go to "Checkout procedure" on page 148. Replace the system-board and chassis assembly, as described in "Replacing the Tier 2 system-board and chassis assembly" on page 229.
C1009x02	Hardware object manager: (HOM): erase HOM IPL step in progress	<ol style="list-style-type: none"> Go to "Checkout procedure" on page 148. Replace the system-board and chassis assembly, as described in "Replacing the Tier 2 system-board and chassis assembly" on page 229.

- If the system hangs on a progress code, follow the suggested actions in the order in which they are listed in the Action column until the problem is solved. If an action solves the problem, you can stop performing there maining actions.
- See *Chapter 3, "Parts listing,"* on page 197 to determine which components are CRUs and which components are FRUs.

Progress code	Description	Action
C1009x04	Hardware object manager: (HOM): build cards IPL step in progress	1. Go to "Checkout procedure" on page 148. 2. Replace the system-board and chassis assembly, as described in "Replacing the Tier 2 system-board and chassis assembly" on page 229.
C1009x08	Hardware object manager: (HOM): build processors IPL step in progress	1. Go to "Checkout procedure" on page 148. 2. Replace the system-board and chassis assembly, as described in "Replacing the Tier 2 system-board and chassis assembly" on page 229.
C1009x0C	Hardware object manager: (HOM): build chips IPL step in progress	1. Go to "Checkout procedure" on page 148. 2. Replace the system-board and chassis assembly, as described in "Replacing the Tier 2 system-board and chassis assembly" on page 229.
C1009x10	Hardware object manager: (HOM): initialize HOM	1. Go to "Checkout procedure" on page 148. 2. Replace the system-board and chassis assembly, as described in "Replacing the Tier 2 system-board and chassis assembly" on page 229.
C1009x14	Hardware object manager: (HOM): validate HOM	1. Go to "Checkout procedure" on page 148. 2. Replace the system-board and chassis assembly, as described in "Replacing the Tier 2 system-board and chassis assembly" on page 229.
C1009x18	Hardware object manager: (HOM): GARD in progress	1. Go to "Checkout procedure" on page 148. 2. Replace the system-board and chassis assembly, as described in "Replacing the Tier 2 system-board and chassis assembly" on page 229.
C1009x1C	Hardware object manager: (HOM): clock test in progress	1. Go to "Checkout procedure" on page 148. 2. Replace the system-board and chassis assembly, as described in "Replacing the Tier 2 system-board and chassis assembly" on page 229.
C1009x20	Frequency control IPL step in progress	1. Go to "Checkout procedure" on page 148. 2. Replace the system-board and chassis assembly, as described in "Replacing the Tier 2 system-board and chassis assembly" on page 229.
C1009x24	Asset protection IPL step in progress	1. Go to "Checkout procedure" on page 148. 2. Replace the system-board and chassis assembly, as described in "Replacing the Tier 2 system-board and chassis assembly" on page 229.
C1009x28	Memory configuration IPL step in progress	1. Go to "Checkout procedure" on page 148. 2. Replace the system-board and chassis assembly, as described in "Replacing the Tier 2 system-board and chassis assembly" on page 229.
C1009x2C	Processor CFAM initialization in progress	1. Go to "Checkout procedure" on page 148. 2. Replace the system-board and chassis assembly, as described in "Replacing the Tier 2 system-board and chassis assembly" on page 229.
C1009x30	Processor self-synchronization in progress	1. Go to "Checkout procedure" on page 148. 2. Replace the system-board and chassis assembly, as described in "Replacing the Tier 2 system-board and chassis assembly" on page 229.
C1009034	Processor mask attentions being initialized	1. Go to "Checkout procedure" on page 148. 2. Replace the system-board and chassis assembly, as described in "Replacing the Tier 2 system-board and chassis assembly" on page 229.

- If the system hangs on a progress code, follow the suggested actions in the order in which they are listed in the Action column until the problem is solved. If an action solves the problem, you can stop performing these remaining actions.
- See *Chapter 3, "Parts listing,"* on page 197 to determine which components are CRUs and which components are FRUs.

Progress code	Description	Action
C1009x38	Processor check ring IPL step in progress	1. Go to "Checkout procedure" on page 148. 2. Replace the system-board and chassis assembly, as described in "Replacing the Tier 2 system-board and chassis assembly" on page 229.
C1009x39	Processor L2 line delete in progress	1. Go to "Checkout procedure" on page 148. 2. Replace the system-board and chassis assembly, as described in "Replacing the Tier 2 system-board and chassis assembly" on page 229.
C1009x3A	Load processor gpnr IPL step in progress	1. Go to "Checkout procedure" on page 148. 2. Replace the system-board and chassis assembly, as described in "Replacing the Tier 2 system-board and chassis assembly" on page 229.
C1009x3C	Processor ABIST step in progress	1. Go to "Checkout procedure" on page 148. 2. Replace the system-board and chassis assembly, as described in "Replacing the Tier 2 system-board and chassis assembly" on page 229.
C1009x40	Processor LBIST step in progress	1. Go to "Checkout procedure" on page 148. 2. Replace the system-board and chassis assembly, as described in "Replacing the Tier 2 system-board and chassis assembly" on page 258.
C1009x44	Processor array initialization step in progress	1. Go to "Checkout procedure" on page 148. 2. Replace the system-board and chassis assembly, as described in "Replacing the Tier 2 system-board and chassis assembly" on page 229.
C1009x46	Processor AVP initialization step in progress	1. Go to "Checkout procedure" on page 148. 2. Replace the system-board and chassis assembly, as described in "Replacing the Tier 2 system-board and chassis assembly" on page 229.
C1009x48	Processor flush IPL step in progress	1. Go to "Checkout procedure" on page 148. 2. Replace the system-board and chassis assembly, as described in "Replacing the Tier 2 system-board and chassis assembly" on page 229.
C1009x4C	Processor wiretest IPL step in progress	1. Go to "Checkout procedure" on page 148. 2. Replace the system-board and chassis assembly, as described in "Replacing the Tier 2 system-board and chassis assembly" on page 258.
C1009x50	Processor long scan IPL step in progress	1. Go to "Checkout procedure" on page 148. 2. Replace the system-board and chassis assembly, as described in "Replacing the Tier 2 system-board and chassis assembly" on page 229.
C1009x54	Start processor clocks IPL step in progress	1. Go to "Checkout procedure" on page 148. 2. Replace the system-board and chassis assembly, as described in "Replacing the Tier 2 system-board and chassis assembly" on page 229.
C1009x58	Processor SCOM initialization step in progress	1. Go to "Checkout procedure" on page 148. 2. Replace the system-board and chassis assembly, as described in "Replacing the Tier 2 system-board and chassis assembly" on page 229.
C1009x5C	Processor interface alignment procedure in progress	1. Go to "Checkout procedure" on page 148. 2. Replace the system-board and chassis assembly, as described in "Replacing the Tier 2 system-board and chassis assembly" on page 229.

- If the system hangs on a progress code, follow the suggested actions in the order in which they are listed in the Action column until the problem is solved. If an action solves the problem, you can stop performing there maining actions.
- See *Chapter 3, "Parts listing,"* on page 197 to determine which components are CRUs and which components are FRUs.

Progress code	Description	Action
C1009x5E	Processor AVP L2 test case in progress	1. Go to "Checkout procedure" on page 148. 2. Replace the system-board and chassis assembly, as described in "Replacing the Tier 2 system-board and chassis assembly" on page 229.
C1009x60	Processor random data test in progress	1. Go to "Checkout procedure" on page 148. 2. Replace the system-board and chassis assembly, as described in "Replacing the Tier 2 system-board and chassis assembly" on page 229.
C1009x64	Processor enable machine check test in progress	1. Go to "Checkout procedure" on page 148. 2. Replace the system-board and chassis assembly, as described in "Replacing the Tier 2 system-board and chassis assembly" on page 229.
C1009x66	Concurrent initialization in progress	1. Go to "Checkout procedure" on page 148. 2. Replace the system-board and chassis assembly, as described in "Replacing the Tier 2 system-board and chassis assembly" on page 229.
C1009x68	Processor fabric initialization step in progress	1. Go to "Checkout procedure" on page 148. 2. Replace the system-board and chassis assembly, as described in "Replacing the Tier 2 system-board and chassis assembly" on page 229.
C1009x6C	Processor PSI initialization step in progress	1. Go to "Checkout procedure" on page 148. 2. Replace the system-board and chassis assembly, as described in "Replacing the Tier 2 system-board and chassis assembly" on page 229.
C1009x70	ASIC CFAM initialization step in progress	1. Go to "Checkout procedure" on page 148. 2. Replace the system-board and chassis assembly, as described in "Replacing the Tier 2 system-board and chassis assembly" on page 229.
C1009x74	ASIC mask attentions being set up	1. Go to "Checkout procedure" on page 148. 2. Replace the system-board and chassis assembly, as described in "Replacing the Tier 2 system-board and chassis assembly" on page 229.
C1009x78	ASIC check rings being set up	1. Go to "Checkout procedure" on page 148. 2. Replace the system-board and chassis assembly, as described in "Replacing the Tier 2 system-board and chassis assembly" on page 229.
C1009x7C	ASIC ABIST test being run	1. Go to "Checkout procedure" on page 148. 2. Replace the system-board and chassis assembly, as described in "Replacing the Tier 2 system-board and chassis assembly" on page 229.
C1009x80	ASIC LBIST test being run	1. Go to "Checkout procedure" on page 148. 2. Replace the system-board and chassis assembly, as described in "Replacing the Tier 2 system-board and chassis assembly" on page 229.
C1009x82	ASIC RGC being reset	1. Go to "Checkout procedure" on page 148. 2. Replace the system-board and chassis assembly, as described in "Replacing the Tier 2 system-board and chassis assembly" on page 229.
C1009x84	ASIC being flushed	1. Go to "Checkout procedure" on page 148. 2. Replace the system-board and chassis assembly, as described in "Replacing the Tier 2 system-board and chassis assembly" on page 229.

- If the system hangs on a progress code, follow the suggested actions in the order in which they are listed in the Action column until the problem is solved. If an action solves the problem, you can stop performing these remaining actions.
- See *Chapter 3, "Parts listing,"* on page 197 to determine which components are CRUs and which components are FRUs.

Progress code	Description	Action
C1009x88	ASIC long scan initialization in progress	1. Go to "Checkout procedure" on page 148. 2. Replace the system-board and chassis assembly, as described in "Replacing the Tier 2 system-board and chassis assembly" on page 229.
C1009x8C	ASIC start clocks in progress	1. Go to "Checkout procedure" on page 148. 2. Replace the system-board and chassis assembly, as described in "Replacing the Tier 2 system-board and chassis assembly" on page 229.
C1009x90	Wire test in progress	1. Go to "Checkout procedure" on page 148. 2. Replace the system-board and chassis assembly, as described in "Replacing the Tier 2 system-board and chassis assembly" on page 229.
C1009x92	ASIC restore erepair in progress	1. Go to "Checkout procedure" on page 148. 2. Replace the system-board and chassis assembly, as described in "Replacing the Tier 2 system-board and chassis assembly" on page 229.
C1009x94	ASIC transmit/receive initialization step in progress	1. Go to "Checkout procedure" on page 148. 2. Replace the system-board and chassis assembly, as described in "Replacing the Tier 2 system-board and chassis assembly" on page 229.
C1009x98	ASIC wrap test in progress	1. Go to "Checkout procedure" on page 148. 2. Replace the system-board and chassis assembly, as described in "Replacing the Tier 2 system-board and chassis assembly" on page 229.
C1009x9C	ASIC SCOM initialization step in progress	1. Go to "Checkout procedure" on page 148. 2. Replace the system-board and chassis assembly, as described in "Replacing the Tier 2 system-board and chassis assembly" on page 229.
C1009x9E	ASIC HSS set up in progress	1. Go to "Checkout procedure" on page 148. 2. Replace the system-board and chassis assembly, as described in "Replacing the Tier 2 system-board and chassis assembly" on page 229.
C1009xA0	ASIC onyx BIST in progress	1. Go to "Checkout procedure" on page 148. 2. Replace the system-board and chassis assembly, as described in "Replacing the Tier 2 system-board and chassis assembly" on page 229.
C1009xA4	ASIC interface alignment step in progress	1. Go to "Checkout procedure" on page 148. 2. Replace the system-board and chassis assembly, as described in "Replacing the Tier 2 system-board and chassis assembly" on page 229.
C1009xA8	ASIC random data test in progress	1. Go to "Checkout procedure" on page 148. 2. Replace the system-board and chassis assembly, as described in "Replacing the Tier 2 system-board and chassis assembly" on page 229.
C1009xAC	ASIC enable machine check step in progress	1. Go to "Checkout procedure" on page 148. 2. Replace the system-board and chassis assembly, as described in "Replacing the Tier 2 system-board and chassis assembly" on page 229.
C1009xB0	ASIC I/O initialization step in progress	1. Go to "Checkout procedure" on page 148. 2. Replace the system-board and chassis assembly, as described in "Replacing the Tier 2 system-board and chassis assembly" on page 229.

- If the system hangs on a progress code, follow the suggested actions in the order in which they are listed in the Action column until the problem is solved. If an action solves the problem, you can stop performing there maining actions.
- See *Chapter 3, "Parts listing,"* on page 197 to determine which components are CRUs and which components are FRUs.

Progress code	Description	Action
C1009xB4	ASIC DRAM initialization step in progress	1. Go to "Checkout procedure" on page 148. 2. Replace the system-board and chassis assembly, as described in "Replacing the Tier 2 system-board and chassis assembly" on page 229.
C1009xB8	ASIC memory diagnostic step in progress	1. Go to "Checkout procedure" on page 148. 2. Replace the system-board and chassis assembly, as described in "Replacing the Tier 2 system-board and chassis assembly" on page 229.
C1009xB9	PSI diagnostic step in progress	1. Go to "Checkout procedure" on page 148. 2. Replace the system-board and chassis assembly, as described in "Replacing the Tier 2 system-board and chassis assembly" on page 229.
C1009xBB	Restore L3 line delete step in progress	1. Go to "Checkout procedure" on page 148. 2. Replace the system-board and chassis assembly, as described in "Replacing the Tier 2 system-board and chassis assembly" on page 229.
C1009xBD	AVP memory test case in progress	1. Go to "Checkout procedure" on page 148. 2. Replace the system-board and chassis assembly, as described in "Replacing the Tier 2 system-board and chassis assembly" on page 229.
C1009xC0	Node interface alignment procedure in progress	1. Go to "Checkout procedure" on page 148. 2. Replace the system-board and chassis assembly, as described in "Replacing the Tier 2 system-board and chassis assembly" on page 229.
C1009xC4	Dump initialization step in progress	1. Go to "Checkout procedure" on page 148. 2. Replace the system-board and chassis assembly, as described in "Replacing the Tier 2 system-board and chassis assembly" on page 229.
C1009xC8	Start PRD step in progress	1. Go to "Checkout procedure" on page 148. 2. Replace the system-board and chassis assembly, as described in "Replacing the Tier 2 system-board and chassis assembly" on page 229.
C1009xCC	Message passing waiting period has begun	1. Go to "Checkout procedure" on page 148. 2. Replace the system-board and chassis assembly, as described in "Replacing the Tier 2 system-board and chassis assembly" on page 229.
C1009xD0	Message passing waiting period has begun	1. Go to "Checkout procedure" on page 148. 2. Replace the system-board and chassis assembly, as described in "Replacing the Tier 2 system-board and chassis assembly" on page 229.
C1009xD4	Starting elastic interface calibration	1. Go to "Checkout procedure" on page 148. 2. Replace the system-board and chassis assembly, as described in "Replacing the Tier 2 system-board and chassis assembly" on page 229.
C103A1xx	Hypervisor code modules are being transferred to system storage	1. Go to "Checkout procedure" on page 148. 2. Replace the system-board and chassis assembly, as described in "Replacing the Tier 2 system-board and chassis assembly" on page 229.
C103A2xx	Hypervisor data areas are being built in system storage	1. Go to "Checkout procedure" on page 148. 2. Replace the system-board and chassis assembly, as described in "Replacing the Tier 2 system-board and chassis assembly" on page 229.

- If the system hangs on a progress code, follow the suggested actions in the order in which they are listed in the Action column until the problem is solved. If an action solves the problem, you can stop performing these remaining actions.
- See *Chapter 3, "Parts listing,"* on page 197 to determine which components are CRUs and which components are FRUs.

Progress code	Description	Action
C103A3xx	Hypervisor data structures are being transferred to system storage	<ol style="list-style-type: none"> 1. Go to "Checkout procedure" on page 148. 2. Replace the system-board and chassis assembly, as described in "Replacing the Tier 2 system-board and chassis assembly" on page 229.
C103A400	Special purpose registers are loaded and instructions are started on the system processors	<ol style="list-style-type: none"> 1. Go to "Checkout procedure" on page 148. 2. Replace the system-board and chassis assembly, as described in "Replacing the Tier 2 system-board and chassis assembly" on page 229.
C103A401	Instructions have been started on the system processors	<ol style="list-style-type: none"> 1. Go to "Checkout procedure" on page 148. 2. Replace the system-board and chassis assembly, as described in "Replacing the Tier 2 system-board and chassis assembly" on page 229.
C116C2xx	System power interface is listening for power fault events from SPCN. The last byte (xx) will increment up from 00 to 1F every second while it waits.	<ol style="list-style-type: none"> 1. Go to "Checkout procedure" on page 148. 2. Replace the system-board and chassis assembly, as described in "Replacing the Tier 2 system-board and chassis assembly" on page 229.
C162E4xyy	VPD is being collected; yy indicates the type of device from which VPD is being collected	<ol style="list-style-type: none"> 1. Go to "Checkout procedure" on page 148. 2. Replace the system-board and chassis assembly, as described in "Replacing the Tier 2 system-board and chassis assembly" on page 229.
C1645300	Starting a data synchronization operation between the primary service processor and the secondary service processor.	<ol style="list-style-type: none"> 1. Go to "Checkout procedure" on page 148. 2. Replace the system-board and chassis assembly, as described in "Replacing the Tier 2 system-board and chassis assembly" on page 229.

2.4.2.2 C2001000 to C20082FF Virtual service processor checkpoints

The C2xx progress codes indicate the progress of a partition IPL that is controlled by the virtual service processor. The virtual service processor progress codes end after the environment setup completes and the specific operating system code continues the IPL.

The virtual service processor can start a variety of operating systems. Some codes are specific to an operating system and therefore, do not apply to all operating systems.

Table 16 lists the progress codes that might be displayed during the power-on self-test (POST), along with suggested actions to take if the system hangs on the progress code. Only when you experience a hang condition should you take any of the actions described for a progress code.

In the following progress codes, x can be any number or letter.

Table 2-16. C2001000 to C20082FF checkpoints

Progress code	Description	Action
C2001000	Partition auto-startup during a platform startup	1. Go to "Recovering the system firmware" on page 186. 2. Replace the system-board and chassis assembly, as described in "Replacing the Tier 2 system-board and chassis assembly" on page 229.
C2001010	Startup source	1. Go to "Recovering the system firmware" on page 186. 2. Replace the system-board and chassis assembly, as described in "Replacing the Tier 2 system-board and chassis assembly" on page 229.
C2001100	Adding partition resources to the secondary configuration	1. Go to "Recovering the system firmware" on page 186. 2. Replace the system-board and chassis assembly, as described in "Replacing the Tier 2 system-board and chassis assembly" on page 229.
C20011FF	Partition resources added successfully	1. Go to "Recovering the system firmware" on page 186. 2. Replace the system-board and chassis assembly, as described in "Replacing the Tier 2 system-board and chassis assembly" on page 229.
C2001200	Checking if startup is allowed	1. Go to "Recovering the system firmware" on page 186. 2. Replace the system-board and chassis assembly, as described in "Replacing the Tier 2 system-board and chassis assembly" on page 229.
C20012FF	Partition startup is allowed to proceed	1. Go to "Recovering the system firmware" on page 186. 2. Replace the system-board and chassis assembly, as described in "Replacing the Tier 2 system-board and chassis assembly" on page 229.
C2001300	Initializing ISL roadmap	1. Go to "Recovering the system firmware" on page 186. 2. Replace the system-board and chassis assembly, as described in "Replacing the Tier 2 system-board and chassis assembly" on page 229.

- If the system hangs on a progress code, follow the suggested actions in the order in which they are listed in the Action column until the problem is solved. If an action solves the problem, you can stop performing the remaining actions.
- See Chapter 3, "Parts listing," on page 197 to determine which components are CRUs and which components are FRUs.

- If the system hangs on a progress code, follow the suggested actions in the order in which they are listed in the Action column until the problem is solved. If an action solves the problem, you can stop performing the remaining actions.
- See *Chapter 3, "Parts listing,"* on page 197 to determine which components are CRUs and which components are FRUs.

Progress code	Description	Action
C20013FF	ISL roadmap initialized successfully	1. Go to "Recovering the system firmware" on page 186. 2. Replace the system-board and chassis assembly, as described in "Replacing the Tier 2 system-board and chassis assembly" on page 229.
C2001400	Initializing SP™ Communication Area #1	1. Go to "Recovering the system firmware" on page 186. 2. Replace the system-board and chassis assembly, as described in "Replacing the Tier 2 system-board and chassis assembly" on page 229.
C2001410	Initializing startup parameters	1. Go to "Recovering the system firmware" on page 186. 2. Replace the system-board and chassis assembly, as described in "Replacing the Tier 2 system-board and chassis assembly" on page 229.
C20014FF	Startup parameters initialized successfully	1. Go to "Recovering the system firmware" on page 186. 2. Replace the system-board and chassis assembly, as described in "Replacing the Tier 2 system-board and chassis assembly" on page 229.
C2002100	Power on racks	1. Go to "Recovering the system firmware" on page 186. 2. Replace the system-board and chassis assembly, as described in "Replacing the Tier 2 system-board and chassis assembly" on page 229.
C2002110	Issuing a power on command	1. Go to "Recovering the system firmware" on page 186. 2. Replace the system-board and chassis assembly, as described in "Replacing the Tier 2 system-board and chassis assembly" on page 229.
C200211F	Power on command successful	1. Go to "Recovering the system firmware" on page 186. 2. Replace the system-board and chassis assembly, as described in "Replacing the Tier 2 system-board and chassis assembly" on page 229.
C20021FF	Power on phase complete	1. Go to "Recovering the system firmware" on page 186. 2. Replace the system-board and chassis assembly, as described in "Replacing the Tier 2 system-board and chassis assembly" on page 229.
C2002200	Begin acquiring slot locks	1. Go to "Recovering the system firmware" on page 186. 2. Replace the system-board and chassis assembly, as described in "Replacing the Tier 2 system-board and chassis assembly" on page 229.
C20022FF	End acquiring slot locks	1. Go to "Recovering the system firmware" on page 186. 2. Replace the system-board and chassis assembly, as described in "Replacing the Tier 2 system-board and chassis assembly" on page 229.
C2002300	Begin acquiring VIO slot locks	1. Go to "Recovering the system firmware" on page 186. 2. Replace the system-board and chassis assembly, as described in "Replacing the Tier 2 system-board and chassis assembly" on page 229.
C20023FF	End acquiring VIO slot locks	1. Go to "Recovering the system firmware" on page 186. 2. Replace the system-board and chassis assembly, as described in "Replacing the Tier 2 system-board and chassis assembly" on page 229.
C2002400	Begin powering on slots	1. Go to "Recovering the system firmware" on page 186. 2. Replace the system-board and chassis assembly, as described in "Replacing the Tier 2 system-board and chassis assembly" on page 229.

- If the system hangs on a progress code, follow the suggested actions in the order in which they are listed in the Action column until the problem is solved. If an action solves the problem, you can stop performing the remaining actions.
- See *Chapter 3, "Parts listing,"* on page 197 to determine which components are CRUs and which components are FRUs.

Progress code	Description	Action
C2002450	Waiting for power on of slots to complete	1. Go to "Recovering the system firmware" on page 186. 2. Replace the system-board and chassis assembly, as described in "Replacing the Tier 2 system-board and chassis assembly" on page 229.
C20024FF	End powering on slots	1. Go to "Recovering the system firmware" on page 186. 2. Replace the system-board and chassis assembly, as described in "Replacing the Tier 2 system-board and chassis assembly" on page 229.
C2002500	Begin power on VIO slots	1. Go to "Recovering the system firmware" on page 186. 2. Replace the system-board and chassis assembly, as described in "Replacing the Tier 2 system-board and chassis assembly" on page 229.
C20025FF	End powering on VIO slots	1. Go to "Recovering the system firmware" on page 186. 2. Replace the system-board and chassis assembly, as described in "Replacing the Tier 2 system-board and chassis assembly" on page 229.
C2003100	Validating ISL command parameters	1. Go to "Recovering the system firmware" on page 186. 2. Replace the system-board and chassis assembly, as described in "Replacing the Tier 2 system-board and chassis assembly" on page 229.
C2003111	Waiting for bus object to become operational	1. Go to "Recovering the system firmware" on page 186. 2. Replace the system-board and chassis assembly, as described in "Replacing the Tier 2 system-board and chassis assembly" on page 229.
C2003112	Waiting for bus unit to become disabled	1. Go to "Recovering the system firmware" on page 186. 2. Replace the system-board and chassis assembly, as described in "Replacing the Tier 2 system-board and chassis assembly" on page 229.
C2003115	Waiting for creation of bus object	1. Go to "Recovering the system firmware" on page 186. 2. Replace the system-board and chassis assembly, as described in "Replacing the Tier 2 system-board and chassis assembly" on page 229.
C2003150	Sending ISL command to bus unit	1. Go to "Recovering the system firmware" on page 186. 2. Replace the system-board and chassis assembly, as described in "Replacing the Tier 2 system-board and chassis assembly" on page 229.
C20031FF	Waiting for ISL command completion	1. Go to "Recovering the system firmware" on page 186. 2. Replace the system-board and chassis assembly, as described in "Replacing the Tier 2 system-board and chassis assembly" on page 229.
C20032FF	ISL command complete successfully	1. Go to "Recovering the system firmware" on page 186. 2. Replace the system-board and chassis assembly, as described in "Replacing the Tier 2 system-board and chassis assembly" on page 229.
C2003300	Start SoftPOR of a failed ISL slot	1. Go to "Recovering the system firmware" on page 186. 2. Replace the system-board and chassis assembly, as described in "Replacing the Tier 2 system-board and chassis assembly" on page 229.
C2003350	Waiting for SoftPOR of a failed ISL slot	1. Go to "Recovering the system firmware" on page 186. 2. Replace the system-board and chassis assembly, as described in "Replacing the Tier 2 system-board and chassis assembly" on page 229.

- If the system hangs on a progress code, follow the suggested actions in the order in which they are listed in the Action column until the problem is solved. If an action solves the problem, you can stop performing the remaining actions.
- See *Chapter 3, "Parts listing,"* on page 197 to determine which components are CRUs and which components are FRUs.

Progress code	Description	Action
C20033FF	Finish SoftPOR of a failed ISL slot	1. Go to "Recovering the system firmware" on page 186. 2. Replace the system-board and chassis assembly, as described in "Replacing the Tier 2 system-board and chassis assembly" on page 229.
C2004100	Waiting for load source device to enlist	1. Go to "Recovering the system firmware" on page 186. 2. Replace the system-board and chassis assembly, as described in "Replacing the Tier 2 system-board and chassis assembly" on page 229.
C2004200	Load source device has enlisted	1. Go to "Recovering the system firmware" on page 186. 2. Replace the system-board and chassis assembly, as described in "Replacing the Tier 2 system-board and chassis assembly" on page 229.
C2004300	Preparing connection to load source device	1. Go to "Recovering the system firmware" on page 186. 2. Replace the system-board and chassis assembly, as described in "Replacing the Tier 2 system-board and chassis assembly" on page 229.
C20043FF	Load source device is connected	1. Go to "Recovering the system firmware" on page 186. 2. Replace the system-board and chassis assembly, as described in "Replacing the Tier 2 system-board and chassis assembly" on page 229.
C2006000	Locating first LID information on the load source	1. Go to "Recovering the system firmware" on page 186. 2. Replace the system-board and chassis assembly, as described in "Replacing the Tier 2 system-board and chassis assembly" on page 229.
C2006005	Clearing all partition main store	1. Go to "Recovering the system firmware" on page 186. 2. Replace the system-board and chassis assembly, as described in "Replacing the Tier 2 system-board and chassis assembly" on page 229.
C2006010	Locating next LID information on the load source	1. Go to "Recovering the system firmware" on page 186. 2. Replace the system-board and chassis assembly, as described in "Replacing the Tier 2 system-board and chassis assembly" on page 229.
C2006020	Verifying LID information	1. Go to "Recovering the system firmware" on page 186. 2. Replace the system-board and chassis assembly, as described in "Replacing the Tier 2 system-board and chassis assembly" on page 229.
C2006030	Priming LP configuration LID	1. Go to "Recovering the system firmware" on page 186. 2. Replace the system-board and chassis assembly, as described in "Replacing the Tier 2 system-board and chassis assembly" on page 229.
C2006040	Preparing to initiate LID load from load source	1. Go to "Recovering the system firmware" on page 186. 2. Replace the system-board and chassis assembly, as described in "Replacing the Tier 2 system-board and chassis assembly" on page 229.
C2006050	LP configuration LID primed successfully	1. Go to "Recovering the system firmware" on page 186. 2. Replace the system-board and chassis assembly, as described in "Replacing the Tier 2 system-board and chassis assembly" on page 229.
C2006060	Waiting for LID load to complete	1. Go to "Recovering the system firmware" on page 186. 2. Replace the system-board and chassis assembly, as described in "Replacing the Tier 2 system-board and chassis assembly" on page 229.

- If the system hangs on a progress code, follow the suggested actions in the order in which they are listed in the Action column until the problem is solved. If an action solves the problem, you can stop performing the remaining actions.
- See *Chapter 3, "Parts listing,"* on page 197 to determine which components are CRUs and which components are FRUs.

Progress code	Description	Action
C2006100	LID load completed successfully	1. Go to "Recovering the system firmware" on page 186. 2. Replace the system-board and chassis assembly, as described in "Replacing the Tier 2 system-board and chassis assembly" on page 229.
C2006200	Loading raw kernel memory image	1. Go to "Recovering the system firmware" on page 186. 2. Replace the system-board and chassis assembly, as described in "Replacing the Tier 2 system-board and chassis assembly" on page 229.
C20062FF	Loading raw kernel memory image completed successfully	1. Go to "Recovering the system firmware" on page 186. 2. Replace the system-board and chassis assembly, as described in "Replacing the Tier 2 system-board and chassis assembly" on page 229.
C2008040	Begin transfer slot locks to partition	1. Go to "Recovering the system firmware" on page 186. 2. Replace the system-board and chassis assembly, as described in "Replacing the Tier 2 system-board and chassis assembly" on page 229.
C2008060	End transfer slot locks to partition	1. Go to "Recovering the system firmware" on page 186. 2. Replace the system-board and chassis assembly, as described in "Replacing the Tier 2 system-board and chassis assembly" on page 229.
C2008080	Begin transfer VIO slot locks to partition	1. Go to "Recovering the system firmware" on page 186. 2. Replace the system-board and chassis assembly, as described in "Replacing the Tier 2 system-board and chassis assembly" on page 229.
C20080A0	End transfer VIO slot locks to partition	1. Go to "Recovering the system firmware" on page 186. 2. Replace the system-board and chassis assembly, as described in "Replacing the Tier 2 system-board and chassis assembly" on page 229.
C20080FF	Hypervisor low-level session manager object is ready	1. Go to "Recovering the system firmware" on page 186. 2. Replace the system-board and chassis assembly, as described in "Replacing the Tier 2 system-board and chassis assembly" on page 229.
C2008100	Initializing service processor communication area #2	1. Go to "Recovering the system firmware" on page 186. 2. Replace the system-board and chassis assembly, as described in "Replacing the Tier 2 system-board and chassis assembly" on page 229.
C2008104	Loading data structures into main store	1. Go to "Recovering the system firmware" on page 186. 2. Replace the system-board and chassis assembly, as described in "Replacing the Tier 2 system-board and chassis assembly" on page 229.
C2008110	Initializing event paths	1. Go to "Recovering the system firmware" on page 186. 2. Replace the system-board and chassis assembly, as described in "Replacing the Tier 2 system-board and chassis assembly" on page 229.
C2008120	Starting processor(s)	1. Go to "Recovering the system firmware" on page 186. 2. Replace the system-board and chassis assembly, as described in "Replacing the Tier 2 system-board and chassis assembly" on page 229.
C2008130	Begin associate of system ports	1. Go to "Recovering the system firmware" on page 186. 2. Replace the system-board and chassis assembly, as described in "Replacing the Tier 2 system-board and chassis assembly" on page 229.

- If the system hangs on a progress code, follow the suggested actions in the order in which they are listed in the Action column until the problem is solved. If an action solves the problem, you can stop performing the remaining actions.
- See *Chapter 3, "Parts listing,"* on page 197 to determine which components are CRUs and which components are FRUs.

Progress code	Description	Action
C2008138	Associating system ports to the partition	1. Go to "Recovering the system firmware" on page 186. 2. Replace the system-board and chassis assembly, as described in "Replacing the Tier 2 system-board and chassis assembly" on page 229.
C200813F	End associate of system ports	1. Go to "Recovering the system firmware" on page 186. 2. Replace the system-board and chassis assembly, as described in "Replacing the Tier 2 system-board and chassis assembly" on page 229.
C20081FF	Processors started successfully, now waiting to receive the continue acknowledgement from system firmware	1. Go to "Recovering the system firmware" on page 186. 2. Replace the system-board and chassis assembly, as described in "Replacing the Tier 2 system-board and chassis assembly" on page 229.
C2008200	Continue acknowledgement received from system firmware	1. Go to "Recovering the system firmware" on page 186. 2. Replace the system-board and chassis assembly, as described in "Replacing the Tier 2 system-board and chassis assembly" on page 229.
C20082FF	VSP startup complete successfully	1. Go to "Recovering the system firmware" on page 186. 2. Replace the system-board and chassis assembly, as described in "Replacing the Tier 2 system-board and chassis assembly" on page 229.

2.4.2.3 IPL status progress codes

A server that stalls during an initial program load (IPL) of the operating system indicates a problem with the operating system code or hardware configuration.

2.4.2.4 C700xxxx Server firmware IPL status checkpoints:

A server that stalls during an initial program load (IPL) of the server firmware indicates a problem with the server firmware code. If the C700 progress that you see is not C700 4091, your only service action is to collect information on words 3 and 4 of the SRC, and to call your next level of support.

Table 2-17 shows the form of the C700xxxx progress codes, where xxxx can be any number or letter.

- If the system hangs on a progress code, follow the suggested actions in the order in which they are listed in the Action column until the problem is solved. If an action solves the problem, you can stop performing the remaining actions.
- See *Chapter 3, "Parts listing,"* on page 197 to determine which components are CRUs and which components are FRUs.

Table 2-17. C700xxxx Server firmware IPL status checkpoints

Progress code	Description	Action
C700xxxx	A problem has occurred with the system firmware during startup.	<ol style="list-style-type: none"> 1. Shutdown and restart the blade server from the permanent-side image. 2. Check for updates to the system firmware. 3. Update the firmware. 4. Go to “Checkout procedure” on page 148. 5. Replace the system-board and chassis assembly, as described in “Replacing the Tier 2 system-board and chassis assembly” on page 229.

2.4.2.5 CA000000 to CA2799FF Partition firmware checkpoints

The CAxx partition firmware progress codes provide information about the progress of partition firmware as it is initializing. In some cases, a server might hang (or stall) at one of these progress codes without displaying an 8-character system reference code (SRC).

Table 18 lists the progress codes that might be displayed during the power-on self-test (POST), along with suggested actions to take if the system hangs on the progress code. Only when you experience a hang condition should you take any of the actions described for a progress code.

In the following progress codes, x can be any number or letter.

Table 2-18. CA000000 to CA2799FF checkpoints

<ul style="list-style-type: none"> • If the system hangs on a progress code, follow the suggested actions in the order in which they are listed in the Action column until the problem is solved. If an action solves the problem, you can stop performing the remaining actions. • See Chapter 3, “Parts listing,” on page 197 to determine which components are CRUs and which components are FRUs. 		
Progress code	Description	Action
CA000000	Process control now owned by partition firmware	<ol style="list-style-type: none"> 1. Go to “Checkout procedure” on page 148. 2. Replace the system-board and chassis assembly, as described in “Replacing the Tier 2 system-board and chassis assembly” on page 229.
CA000020	Checking firmware levels	<ol style="list-style-type: none"> 1. Go to “Checkout procedure” on page 148. 2. Replace the system-board and chassis assembly, as described in “Replacing the Tier 2 system-board and chassis assembly” on page 229.
CA000030	Attempting to establish a communication link by using lpevents	<ol style="list-style-type: none"> 1. Go to “Checkout procedure” on page 148. 2. Replace the system-board and chassis assembly, as described in “Replacing the Tier 2 system-board and chassis assembly” on page 229.
CA000032	Attempting to register lpevent queues	<ol style="list-style-type: none"> 1. Go to “Checkout procedure” on page 148. 2. Replace the system-board and chassis assembly, as described in “Replacing the Tier 2 system-board and chassis assembly” on page 229.

- If the system hangs on a progress code, follow the suggested actions in the order in which they are listed in the Action column until the problem is solved. If an action solves the problem, you can stop performing the remaining actions.
- See *Chapter 3, "Parts listing,"* on page 197 to determine which components are CRUs and which components are FRUs.

Progress code	Description	Action
CA000034	Attempting to exchange cap and allocate lpevents	<ol style="list-style-type: none"> 1. Go to "Checkout procedure" on page 148. 2. Replace the system-board and chassis assembly, as described in "Replacing the Tier 2 system-board and chassis assembly" on page 229.
CA000038	Attempting to exchange virtual continue events	<ol style="list-style-type: none"> 1. Go to "Checkout procedure" on page 148. 2. Replace the system-board and chassis assembly, as described in "Replacing the Tier 2 system-board and chassis assembly" on page 229.
CA000040	Attempting to obtain RTAS firmware details	<ol style="list-style-type: none"> 1. Go to "Checkout procedure" on page 148. 2. Replace the system-board and chassis assembly, as described in "Replacing the Tier 2 system-board and chassis assembly" on page 229.
CA000050	Attempting to load RTAS firmware	<ol style="list-style-type: none"> 1. Go to "Checkout procedure" on page 148. 2. Replace the system-board and chassis assembly, as described in "Replacing the Tier 2 system-board and chassis assembly" on page 229.
CA000060	Attempting to obtain open firmware details	<ol style="list-style-type: none"> 1. Go to "Checkout procedure" on page 148. 2. Replace the system-board and chassis assembly, as described in "Replacing the Tier 2 system-board and chassis assembly" on page 229.
CA000070	Attempting to load open firmware	<ol style="list-style-type: none"> 1. Go to "Checkout procedure" on page 148. 2. Replace the system-board and chassis assembly, as described in "Replacing the Tier 2 system-board and chassis assembly" on page 229.
CA000080	Preparing to start open firmware	<ol style="list-style-type: none"> 1. Go to "Checkout procedure" on page 148. 2. Replace the system-board and chassis assembly, as described in "Replacing the Tier 2 system-board and chassis assembly" on page 229.
CA000090	Open firmware package corrupted (phase 1)	<ol style="list-style-type: none"> 1. Reboot the blade server. 2. If the problem persists: <ol style="list-style-type: none"> a. Go to "Checkout procedure" on page 148. b. Replace the system-board and chassis assembly, as described in "Replacing the Tier 2 system-board and chassis assembly" on page 229.
CA000091	Attempting to load the second pass of C code	<ol style="list-style-type: none"> 1. Go to "Checkout procedure" on page 148. 2. Replace the system-board and chassis assembly, as described in "Replacing the Tier 2 system-board and chassis assembly" on page 229.
CA0000A0	Open firmware package corrupted (phase 2)	<ol style="list-style-type: none"> 1. Go to "Checkout procedure" on page 148. 2. Replace the system-board and chassis assembly, as described in "Replacing the Tier 2 system-board and chassis assembly" on page 229.
CA00D001	PCI probe process completed, create PCI bridge interrupt routing properties	<ol style="list-style-type: none"> 1. Go to "Checkout procedure" on page 148. 2. Replace the system-board and chassis assembly, as described in "Replacing the Tier 2 system-board and chassis assembly" on page 229.

- If the system hangs on a progress code, follow the suggested actions in the order in which they are listed in the Action column until the problem is solved. If an action solves the problem, you can stop performing the remaining actions.
- See *Chapter 3, "Parts listing,"* on page 197 to determine which components are CRUs and which components are FRUs.

Progress code	Description	Action
CA00D002	PCI adapter NVRAM hint created; system is rebooting	1. Go to "Checkout procedure" on page 148. 2. Replace the system-board and chassis assembly, as described in "Replacing the Tier 2 system-board and chassis assembly" on page 229.
CA00D003	PCI probing complete	1. Go to "Checkout procedure" on page 148. 2. Replace the system-board and chassis assembly, as described in "Replacing the Tier 2 system-board and chassis assembly" on page 229.
CA00D004	Beginning of install-console, loading GUI package	1. Go to "Checkout procedure" on page 148. 2. Replace the system-board and chassis assembly, as described in "Replacing the Tier 2 system-board and chassis assembly" on page 229.
CA00D008	Initialize console and flush queues	1. Go to "Checkout procedure" on page 148. 2. Replace the system-board and chassis assembly, as described in "Replacing the Tier 2 system-board and chassis assembly" on page 229.
CA00D00C	The partition firmware is about to search for an NVRAM script	1. Go to "Checkout procedure" on page 148. 2. Replace the system-board and chassis assembly, as described in "Replacing the Tier 2 system-board and chassis assembly" on page 229.
CA00D00D	Evaluating NVRAM script	1. Go to "Checkout procedure" on page 148. 2. Replace the system-board and chassis assembly, as described in "Replacing the Tier 2 system-board and chassis assembly" on page 229.
CA00D010	First pass open firmware initialization complete; establish parameters for restart	1. Go to "Checkout procedure" on page 148. 2. Replace the system-board and chassis assembly, as described in "Replacing the Tier 2 system-board and chassis assembly" on page 229.
CA00D011	First pass open firmware initialization complete; control returned to initialization firmware	1. Go to "Checkout procedure" on page 148. 2. Replace the system-board and chassis assembly, as described in "Replacing the Tier 2 system-board and chassis assembly" on page 229.
CA00D012	Second pass open firmware initialization complete; control returned to initialization firmware	1. Go to "Checkout procedure" on page 148. 2. Replace the system-board and chassis assembly, as described in "Replacing the Tier 2 system-board and chassis assembly" on page 229.
CA00D013	Runtime open firmware initialization complete; control returned to initialization firmware	1. Go to "Checkout procedure" on page 148. 2. Replace the system-board and chassis assembly, as described in "Replacing the Tier 2 system-board and chassis assembly" on page 229.
CA00D020	About to download the run the SLIC loader (IOP-less boot)	1. Go to "Checkout procedure" on page 148. 2. Replace the system-board and chassis assembly, as described in "Replacing the Tier 2 system-board and chassis assembly" on page 229.
CA00D021	About to download the run the IO Reporter (for VPD collection)	1. Go to "Checkout procedure" on page 148. 2. Replace the system-board and chassis assembly, as described in "Replacing the Tier 2 system-board and chassis assembly" on page 229.

- If the system hangs on a progress code, follow the suggested actions in the order in which they are listed in the Action column until the problem is solved. If an action solves the problem, you can stop performing the remaining actions.
- See *Chapter 3, "Parts listing,"* on page 197 to determine which components are CRUs and which components are FRUs.

Progress code	Description	Action
CA00E101	Create RTAS node	<ol style="list-style-type: none"> 1. Go to "Checkout procedure" on page 148. 2. Replace the system-board and chassis assembly, as described in "Replacing the Tier 2 system-board and chassis assembly" on page 229.
CA00E102	Load and initialize RTAS	<ol style="list-style-type: none"> 1. Go to "Checkout procedure" on page 148. 2. Replace the system-board and chassis assembly, as described in "Replacing the Tier 2 system-board and chassis assembly" on page 229.
CA00E105	Transfer control to operating system (normal mode boot)	Go to "Boot problem resolution" on page 156.
CA00E10A	Load RTAS device tree	<ol style="list-style-type: none"> 1. Go to "Checkout procedure" on page 148. 2. Replace the system-board and chassis assembly, as described in "Replacing the Tier 2 system-board and chassis assembly" on page 229.
CA00E10B	Set RTAS device properties	<ol style="list-style-type: none"> 1. Go to "Checkout procedure" on page 148. 2. Replace the system-board and chassis assembly, as described in "Replacing the Tier 2 system-board and chassis assembly" on page 229.
CA00E110	Create KDUMP properties	<ol style="list-style-type: none"> 1. Reboot the blade server. 2. If the problem persists: <ol style="list-style-type: none"> a. Go to "Checkout procedure" on page 148. b. Replace the system-board and chassis assembly, as described in "Replacing the Tier 2 system-board and chassis assembly" on page 229.
CA00E130	Build device tree	<ol style="list-style-type: none"> 1. Go to "Checkout procedure" on page 148. 2. Replace the system-board and chassis assembly, as described in "Replacing the Tier 2 system-board and chassis assembly" on page 229.
CA00E131	Create root node properties	<ol style="list-style-type: none"> 1. Reboot the blade server. 2. If the problem persists: <ol style="list-style-type: none"> a. Go to "Checkout procedure" on page 148. b. Replace the system-board and chassis assembly, as described in "Replacing the Tier 2 system-board and chassis assembly" on page 229.
CA00E134	Create memory node	<ol style="list-style-type: none"> 1. Go to "Checkout procedure" on page 148. 2. Replace the system-board and chassis assembly, as described in "Replacing the Tier 2 system-board and chassis assembly" on page 229.
CA00E135	Create HCA node	<ol style="list-style-type: none"> 1. Go to "Checkout procedure" on page 148. 2. Replace the system-board and chassis assembly, as described in "Replacing the Tier 2 system-board and chassis assembly" on page 229.
CA00E136	Create BSR node	<ol style="list-style-type: none"> 1. Go to "Checkout procedure" on page 148. 2. Replace the system-board and chassis assembly, as described in "Replacing the Tier 2 system-board and chassis assembly" on page 229.

- If the system hangs on a progress code, follow the suggested actions in the order in which they are listed in the Action column until the problem is solved. If an action solves the problem, you can stop performing the remaining actions.
- See *Chapter 3, "Parts listing,"* on page 197 to determine which components are CRUs and which components are FRUs.

Progress code	Description	Action
CA00E137	Create HEA node	<ol style="list-style-type: none"> 1. Reboot the blade server. 2. If the problem persists: <ol style="list-style-type: none"> a. Go to "Checkout procedure" on page 148. b. Replace the system-board and chassis assembly, as described in "Replacing the Tier 2 system-board and chassis assembly" on page 229.
CA00E138	Create options node	<ol style="list-style-type: none"> 1. Go to "Checkout procedure" on page 148. 2. Replace the system-board and chassis assembly, as described in "Replacing the Tier 2 system-board and chassis assembly" on page 229.
CA00E139	Create aliases node and system aliases	<ol style="list-style-type: none"> 1. Go to "Checkout procedure" on page 148. 2. Replace the system-board and chassis assembly, as described in "Replacing the Tier 2 system-board and chassis assembly" on page 229.
CA00E13A	Create packages node	<ol style="list-style-type: none"> 1. Go to "Checkout procedure" on page 148. 2. Replace the system-board and chassis assembly, as described in "Replacing the Tier 2 system-board and chassis assembly" on page 229.
CA00E13B	Create HEA node	<ol style="list-style-type: none"> 1. Reboot the blade server. 2. If the problem persists: <ol style="list-style-type: none"> a. Go to "Checkout procedure" on page 148. b. Replace the system-board and chassis assembly, as described in "Replacing the Tier 2 system-board and chassis assembly" on page 229.
CA00E13C	Create HEA port node	<ol style="list-style-type: none"> 1. Reboot the blade server. 2. If the problem persists: <ol style="list-style-type: none"> a. Go to "Checkout procedure" on page 148. b. Replace the system-board and chassis assembly, as described in "Replacing the Tier 2 system-board and chassis assembly" on page 229.
CA00E140	Loading operating system	Go to "Boot problem resolution" on page 156.
CA00E141	Synchronizing the operating system bootlist to the management module bootlist	<ol style="list-style-type: none"> 1. Reboot the blade server. 2. If the problem persists: <ol style="list-style-type: none"> a. Go to "Checkout procedure" on page 148. b. Replace the system-board and chassis assembly, as described in "Replacing the Tier 2 system-board and chassis assembly" on page 229.

- If the system hangs on a progress code, follow the suggested actions in the order in which they are listed in the Action column until the problem is solved. If an action solves the problem, you can stop performing the remaining actions.
- See *Chapter 3, "Parts listing,"* on page 197 to determine which components are CRUs and which components are FRUs.

Progress code	Description	Action
CA00E142	The management module bootlist is being set from the operating system bootlist	<ol style="list-style-type: none"> 1. Reboot the blade server. 2. If the problem persists: <ol style="list-style-type: none"> a. Go to "Checkout procedure" on page 148. b. Replace the system-board and chassis assembly, as described in "Replacing the Tier 2 system-board and chassis assembly" on page 229.
CA00E143	The operating system bootlist is being set from the management module bootlist	<ol style="list-style-type: none"> 1. Reboot the blade server. 2. If the problem persists: <ol style="list-style-type: none"> a. Go to "Checkout procedure" on page 148. b. Replace the system-board and chassis assembly, as described in "Replacing the Tier 2 system-board and chassis assembly" on page 229.
CA00E149	Create boot manager node	<ol style="list-style-type: none"> 1. Go to "Checkout procedure" on page 148. 2. Replace the system-board and chassis assembly, as described in "Replacing the Tier 2 system-board and chassis assembly" on page 229.
CA00E14C	Create terminal emulator node	<ol style="list-style-type: none"> 1. Go to "Checkout procedure" on page 148. 2. Replace the system-board and chassis assembly, as described in "Replacing the Tier 2 system-board and chassis assembly" on page 229.
CA00E14D	Load boot image	Go to "Boot problem resolution" on page 156.
CA00E150	Create host (primary) node	<ol style="list-style-type: none"> 1. Go to "Checkout procedure" on page 148. 2. Replace the system-board and chassis assembly, as described in "Replacing the Tier 2 system-board and chassis assembly" on page 229.
CA00E151	Probing PCI bus	<ol style="list-style-type: none"> 1. Go to "Checkout procedure" on page 148. 2. Replace the system-board and chassis assembly, as described in "Replacing the Tier 2 system-board and chassis assembly" on page 229.
CA00E152	Probing for adapter FCODE; evaluate if present	<ol style="list-style-type: none"> 1. Go to "Checkout procedure" on page 148. 2. Replace the system-board and chassis assembly, as described in "Replacing the Tier 2 system-board and chassis assembly" on page 229.
CA00E153	End adapter FCODE probing and evaluation	<ol style="list-style-type: none"> 1. Go to "Checkout procedure" on page 148. 2. Replace the system-board and chassis assembly, as described in "Replacing the Tier 2 system-board and chassis assembly" on page 229.
CA00E154	Create PCI bridge node	<ol style="list-style-type: none"> 1. Go to "Checkout procedure" on page 148. 2. Replace the system-board and chassis assembly, as described in "Replacing the Tier 2 system-board and chassis assembly" on page 229.
CA00E155	Probing PCI bridge secondary bus	<ol style="list-style-type: none"> 1. Go to "Checkout procedure" on page 148. 2. Replace the system-board and chassis assembly, as described in "Replacing the Tier 2 system-board and chassis assembly" on page 229.

- If the system hangs on a progress code, follow the suggested actions in the order in which they are listed in the Action column until the problem is solved. If an action solves the problem, you can stop performing the remaining actions.
- See *Chapter 3, "Parts listing,"* on page 197 to determine which components are CRUs and which components are FRUs.

Progress code	Description	Action
CA00E156	Create plug-in PCI bridge node	1. Go to "Checkout procedure" on page 148. 2. Replace the system-board and chassis assembly, as described in "Replacing the Tier 2 system-board and chassis assembly" on page 229.
CA00E15B	Transfer control to operating system (service mode boot)	Go to "Boot problem resolution" on page 156.
CA00E15F	Adapter VPD evaluation	1. Go to "Checkout procedure" on page 148. 2. Replace the system-board and chassis assembly, as described in "Replacing the Tier 2 system-board and chassis assembly" on page 229.
CA00E170	Start of PCI bus probe	1. Go to "Checkout procedure" on page 148. 2. Replace the system-board and chassis assembly, as described in "Replacing the Tier 2 system-board and chassis assembly" on page 229.
CA00E172	First pass of PCI device probe	1. Go to "Checkout procedure" on page 148. 2. Replace the system-board and chassis assembly, as described in "Replacing the Tier 2 system-board and chassis assembly" on page 229.
CA00E174	Establishing host connection	1. Verify that: <ul style="list-style-type: none"> – The bootp server is correctly configured; then, retry the operation. – The network connections are correct; then, retry the operation. 2. If the problem persists: <ol style="list-style-type: none"> a. Go to "Checkout procedure" on page 148. b. Replace the system-board and chassis assembly, as described in "Replacing the Tier 2 system-board and chassis assembly" on page 229.
CA00E175	Bootp request	1. Verify that: <ul style="list-style-type: none"> – The bootp server is correctly configured; then, retry the operation. – The network connections are correct; then, retry the operation. 2. If the problem persists: <ol style="list-style-type: none"> a. Go to "Checkout procedure" on page 148. b. Replace the system-board and chassis assembly, as described in "Replacing the Tier 2 system-board and chassis assembly" on page 229.

- If the system hangs on a progress code, follow the suggested actions in the order in which they are listed in the Action column until the problem is solved. If an action solves the problem, you can stop performing the remaining actions.
- See *Chapter 3, "Parts listing,"* on page 197 to determine which components are CRUs and which components are FRUs.

Progress code	Description	Action
CA00E176	TFTP file transfer	1. Verify that: <ul style="list-style-type: none"> – The bootp server is correctly configured; then, retry the operation. – The network connections are correct; then, retry the operation. 2. If the problem persists: <ol style="list-style-type: none"> a. Go to <i>"Checkout procedure"</i> on page 148. b. Replace the system-board and chassis assembly, as described in <i>"Replacing the Tier 2 system-board and chassis assembly"</i> on page 229.
CA00E177	Transfer failure due to TFTP error condition	1. Verify that: <ul style="list-style-type: none"> – The bootp server is correctly configured; then, retry the operation. – The network connections are correct; then, retry the operation. 2. If the problem persists: <ol style="list-style-type: none"> a. Go to <i>"Checkout procedure"</i> on page 148. b. Replace the system-board and chassis assembly, as described in <i>"Replacing the Tier 2 system-board and chassis assembly"</i> on page 229.
CA00E178	Initiating TFTP file transfer	1. Verify that: <ul style="list-style-type: none"> – The bootp server is correctly configured; then, retry the operation. – The network connections are correct; then, retry the operation. 2. If the problem persists: <ol style="list-style-type: none"> a. Go to <i>"Checkout procedure"</i> on page 148. b. Replace the system-board and chassis assembly, as described in <i>"Replacing the Tier 2 system-board and chassis assembly"</i> on page 229.
CA00E179	Closing BOOTP	1. Verify that: <ul style="list-style-type: none"> – The bootp server is correctly configured; then, retry the operation. – The network connections are correct; then, retry the operation. 2. If the problem persists: <ol style="list-style-type: none"> a. Go to <i>"Checkout procedure"</i> on page 148. b. Replace the system-board and chassis assembly, as described in <i>"Replacing the Tier 2 system-board and chassis assembly"</i> on page 229.

- If the system hangs on a progress code, follow the suggested actions in the order in which they are listed in the Action column until the problem is solved. If an action solves the problem, you can stop performing the remaining actions.
- See *Chapter 3, "Parts listing,"* on page 197 to determine which components are CRUs and which components are FRUs.

Progress code	Description	Action
CA00E17B	Microprocessor clock speed measurement	<ol style="list-style-type: none"> 1. Go to "Checkout procedure" on page 148. 2. Replace the system-board and chassis assembly, as described in "Replacing the Tier 2 system-board and chassis assembly" on page 229.
CA00E198	The system is rebooting to enact changes that were specified in client-architecture-support	Go to "Boot problem resolution" on page 156.
CA00E199	The system is rebooting to enact changes that were specified in the boot image ELF header	<ol style="list-style-type: none"> 1. Verify that: <ul style="list-style-type: none"> – The bootp server is correctly configured; then, retry the operation. – The network connections are correct; then, retry the operation. 2. If the problem persists: <ol style="list-style-type: none"> a. Go to "Checkout procedure" on page 148. b. Replace the system-board and chassis assembly, as described in "Replacing the Tier 2 system-board and chassis assembly" on page 229.
CA00E19A	NVRAM auto-boot? variable not found - assume FALSE	<ol style="list-style-type: none"> 1. Go to "Checkout procedure" on page 148. 2. Replace the system-board and chassis assembly, as described in "Replacing the Tier 2 system-board and chassis assembly" on page 229.
CA00E19B	NVRAM menu? variable not found - assume FALSE	<ol style="list-style-type: none"> 1. Go to "Checkout procedure" on page 148. 2. Replace the system-board and chassis assembly, as described in "Replacing the Tier 2 system-board and chassis assembly" on page 229.
CA00E19D	Create NVRAM node	<ol style="list-style-type: none"> 1. Go to "Checkout procedure" on page 148. 2. Replace the system-board and chassis assembly, as described in "Replacing the Tier 2 system-board and chassis assembly" on page 229.
CA00E1A0	User requested boot to SMS menus using keyboard entry	<ol style="list-style-type: none"> 1. Go to "Checkout procedure" on page 148. 2. Replace the system-board and chassis assembly, as described in "Replacing the Tier 2 system-board and chassis assembly" on page 229.
CA00E1A1	User requested boot to open firmware prompt using keyboard entry	<ol style="list-style-type: none"> 1. Go to "Checkout procedure" on page 148. 2. Replace the system-board and chassis assembly, as described in "Replacing the Tier 2 system-board and chassis assembly" on page 229.
CA00E1A2	User requested boot using default service mode boot list using keyboard entry	<ol style="list-style-type: none"> 1. Go to "Checkout procedure" on page 148. 2. Replace the system-board and chassis assembly, as described in "Replacing the Tier 2 system-board and chassis assembly" on page 229.
CA00E1A3	User requested boot using customized service mode boot list using keyboard entry	<ol style="list-style-type: none"> 1. Go to "Checkout procedure" on page 148. 2. Replace the system-board and chassis assembly, as described in "Replacing the Tier 2 system-board and chassis assembly" on page 229.

- If the system hangs on a progress code, follow the suggested actions in the order in which they are listed in the Action column until the problem is solved. If an action solves the problem, you can stop performing the remaining actions.
- See *Chapter 3, "Parts listing,"* on page 197 to determine which components are CRUs and which components are FRUs.

Progress code	Description	Action
CA00E1A4	User requested boot to SMS menus	1. Go to "Checkout procedure" on page 148. 2. Replace the system-board and chassis assembly, as described in "Replacing the Tier 2 system-board and chassis assembly" on page 229.
CA00E1A5	User requested boot to open firmware prompt	1. Go to "Checkout procedure" on page 148. 2. Replace the system-board and chassis assembly, as described in "Replacing the Tier 2 system-board and chassis assembly" on page 229.
CA00E1A6	User requested boot using default service mode boot list	1. Go to "Checkout procedure" on page 148. 2. Replace the system-board and chassis assembly, as described in "Replacing the Tier 2 system-board and chassis assembly" on page 229.
CA00E1A7	User requested boot using customized service mode boot list	1. Go to "Checkout procedure" on page 148. 2. Replace the system-board and chassis assembly, as described in "Replacing the Tier 2 system-board and chassis assembly" on page 229.
CA00E1AA	System boot check for NVRAM settings	1. Go to "Checkout procedure" on page 148. 2. Replace the system-board and chassis assembly, as described in "Replacing the Tier 2 system-board and chassis assembly" on page 229.
CA00E1AB	System booting using default service mode boot list	1. Go to "Checkout procedure" on page 148. 2. Replace the system-board and chassis assembly, as described in "Replacing the Tier 2 system-board and chassis assembly" on page 229.
CA00E1AC	System booting using customized service mode boot list	1. Go to "Checkout procedure" on page 148. 2. Replace the system-board and chassis assembly, as described in "Replacing the Tier 2 system-board and chassis assembly" on page 229.
CA00E1AD	System booting to the operating system	1. Go to "Checkout procedure" on page 148. 2. Replace the system-board and chassis assembly, as described in "Replacing the Tier 2 system-board and chassis assembly" on page 229.
CA00E1AE	System booted to SMS multiboot menu using NVRAM settings	1. Go to "Checkout procedure" on page 148. 2. Replace the system-board and chassis assembly, as described in "Replacing the Tier 2 system-board and chassis assembly" on page 229.
CA00E1AF	System booted to SMS utilities menu using NVRAM settings	1. Go to "Checkout procedure" on page 148. 2. Replace the system-board and chassis assembly, as described in "Replacing the Tier 2 system-board and chassis assembly" on page 229.
CA00E1B1	System booting system-directed boot-device repair	1. Go to "Checkout procedure" on page 148. 2. Replace the system-board and chassis assembly, as described in "Replacing the Tier 2 system-board and chassis assembly" on page 229.
CA00E1B2	XOFF received, waiting for XON	1. Go to "Checkout procedure" on page 148. 2. Replace the system-board and chassis assembly, as described in "Replacing the Tier 2 system-board and chassis assembly" on page 229.

- If the system hangs on a progress code, follow the suggested actions in the order in which they are listed in the Action column until the problem is solved. If an action solves the problem, you can stop performing the remaining actions.
- See *Chapter 3, "Parts listing,"* on page 197 to determine which components are CRUs and which components are FRUs.

Progress code	Description	Action
CA00E1B3	XON received	<ol style="list-style-type: none"> 1. Go to "Checkout procedure" on page 148. 2. Replace the system-board and chassis assembly, as described in "Replacing the Tier 2 system-board and chassis assembly" on page 229.
CA00E1B4	System-directed boot-string didn't load an operating system	<ol style="list-style-type: none"> 1. Go to "Checkout procedure" on page 148. 2. Replace the system-board and chassis assembly, as described in "Replacing the Tier 2 system-board and chassis assembly" on page 229.
CA00E1B5	Checking for iSCSI disk aliases	<ol style="list-style-type: none"> 1. Go to "Checkout procedure" on page 148. 2. Replace the system-board and chassis assembly, as described in "Replacing the Tier 2 system-board and chassis assembly" on page 229.
CA00E1D0	Create PCI self configuring SCSI device (SCSD) node	<ol style="list-style-type: none"> 1. Go to "Checkout procedure" on page 148. 2. Replace the system-board and chassis assembly, as described in "Replacing the Tier 2 system-board and chassis assembly" on page 229.
CA00E1D3	Create SCSD block device node (SD)	<ol style="list-style-type: none"> 1. Go to "Checkout procedure" on page 148. 2. Replace the system-board and chassis assembly, as described in "Replacing the Tier 2 system-board and chassis assembly" on page 229.
CA00E1D4	Create SCSD byte device node (ST)	<ol style="list-style-type: none"> 1. Go to "Checkout procedure" on page 148. 2. Replace the system-board and chassis assembly, as described in "Replacing the Tier 2 system-board and chassis assembly" on page 229.
CA00E1DC	Dynamic console selection	<ol style="list-style-type: none"> 1. Go to "Checkout procedure" on page 148. 2. Replace the system-board and chassis assembly, as described in "Replacing the Tier 2 system-board and chassis assembly" on page 229.
CA00E1DD	A graphics adapter has been selected as the firmware console, but the USB keyboard is not attached.	<ol style="list-style-type: none"> 1. Verify that there is a USB keyboard attached to a USB port that is assigned to the partition. 2. If the problem persists: <ol style="list-style-type: none"> a. Go to "Checkout procedure" on page 148. b. Replace the system-board and chassis assembly, as described in "Replacing the Tier 2 system-board and chassis assembly" on page 229.
CA00E1F0	Start out-of-box experience	<ol style="list-style-type: none"> 1. Go to "Checkout procedure" on page 148. 2. Replace the system-board and chassis assembly, as described in "Replacing the Tier 2 system-board and chassis assembly" on page 229.
CA00E1F1	Start self test sequence on one or more devices	<ol style="list-style-type: none"> 1. Go to "Checkout procedure" on page 148. 2. Replace the system-board and chassis assembly, as described in "Replacing the Tier 2 system-board and chassis assembly" on page 229.
CA00E1F2	Power on password prompt	<ol style="list-style-type: none"> 1. Go to "Checkout procedure" on page 148. 2. Replace the system-board and chassis assembly, as described in "Replacing the Tier 2 system-board and chassis assembly" on page 229.

- If the system hangs on a progress code, follow the suggested actions in the order in which they are listed in the Action column until the problem is solved. If an action solves the problem, you can stop performing the remaining actions.
- See *Chapter 3, "Parts listing,"* on page 197 to determine which components are CRUs and which components are FRUs.

Progress code	Description	Action
CA00E1F3	Privileged-access password prompt	1. Go to "Checkout procedure" on page 148. 2. Replace the system-board and chassis assembly, as described in "Replacing the Tier 2 system-board and chassis assembly" on page 229.
CA00E1F4	End self-test sequence on one or more boot devices; begin system management services	1. Go to "Checkout procedure" on page 148. 2. Replace the system-board and chassis assembly, as described in "Replacing the Tier 2 system-board and chassis assembly" on page 229.
CA00E1F5	Build boot device list	1. Go to "Checkout procedure" on page 148. 2. Replace the system-board and chassis assembly, as described in "Replacing the Tier 2 system-board and chassis assembly" on page 229.
CA00E1F6	Determine boot device sequence	1. Go to "Checkout procedure" on page 148. 2. Replace the system-board and chassis assembly, as described in "Replacing the Tier 2 system-board and chassis assembly" on page 229.
CA00E1F7	No boot image located	Go to "Boot problem resolution" on page 156.
CA00E1F8	Build boot device list for SCSD adapters. (The location code of the SCSD adapter being scanned is also displayed.)	1. Go to "Checkout procedure" on page 148. 2. Replace the system-board and chassis assembly, as described in "Replacing the Tier 2 system-board and chassis assembly" on page 229.
CA00E1F9	Build boot device list for fibre-channel adapters. (The location code of the SAN adapter being scanned is also displayed.)	1. Go to "Checkout procedure" on page 148. 2. Replace the system-board and chassis assembly, as described in "Replacing the Tier 2 system-board and chassis assembly" on page 229.
CA00E1FA	Building device list for SCSD adapters. (The device ID and device LUN of the device being scanned is also displayed.)	1. Go to "Checkout procedure" on page 148. 2. Replace the system-board and chassis assembly, as described in "Replacing the Tier 2 system-board and chassis assembly" on page 229.
CA00E1FB	Scan SCSD bus for attached devices	1. Go to "Checkout procedure" on page 148. 2. Replace the system-board and chassis assembly, as described in "Replacing the Tier 2 system-board and chassis assembly" on page 229.
CA00E1FC	Build boot device list for SSA adapters. (The location code of the SSA adapter being scanned is also displayed.)	1. Go to "Checkout procedure" on page 148. 2. Replace the system-board and chassis assembly, as described in "Replacing the Tier 2 system-board and chassis assembly" on page 229.
CA00E1FE	Building device list for fibre-channel (SAN) adapters. (The WWPN of the SAN adapter being scanned is also displayed.)	1. Go to "Checkout procedure" on page 148. 2. Replace the system-board and chassis assembly, as described in "Replacing the Tier 2 system-board and chassis assembly" on page 229.
CA00E1FF	Build device list for fibre-channel (SAN) adapters. (The LUN of the SAN adapter being scanned is also displayed.)	1. Go to "Checkout procedure" on page 148. 2. Replace the system-board and chassis assembly, as described in "Replacing the Tier 2 system-board and chassis assembly" on page 229.
CA00E440	Validate NVRAM, initialize partitions as needed	1. Go to "Checkout procedure" on page 148. 2. Replace the system-board and chassis assembly, as described in "Replacing the Tier 2 system-board and chassis assembly" on page 229.

- If the system hangs on a progress code, follow the suggested actions in the order in which they are listed in the Action column until the problem is solved. If an action solves the problem, you can stop performing the remaining actions.
- See *Chapter 3, "Parts listing,"* on page 197 to determine which components are CRUs and which components are FRUs.

Progress code	Description	Action
CA00E441	Generate /options node NVRAM configuration variable properties	<ol style="list-style-type: none"> 1. Go to "Checkout procedure" on page 148. 2. Replace the system-board and chassis assembly, as described in "Replacing the Tier 2 system-board and chassis assembly" on page 229.
CA00E442	Validate NVRAM partitions	<ol style="list-style-type: none"> 1. Go to "Checkout procedure" on page 148. 2. Replace the system-board and chassis assembly, as described in "Replacing the Tier 2 system-board and chassis assembly" on page 229.
CA00E443	Generate NVRAM configuration variable dictionary words	<ol style="list-style-type: none"> 1. Go to "Checkout procedure" on page 148. 2. Replace the system-board and chassis assembly, as described in "Replacing the Tier 2 system-board and chassis assembly" on page 229.
CA00E444	The NVRAM size is less than 8K bytes	<ol style="list-style-type: none"> 1. Reboot the blade server. 2. If the problem persists: <ol style="list-style-type: none"> a. Go to "Checkout procedure" on page 148. b. Replace the system-board and chassis assembly, as described in "Replacing the Tier 2 system-board and chassis assembly" on page 229.
CA00E701	Create memory VPD	<ol style="list-style-type: none"> 1. Go to "Checkout procedure" on page 148. 2. Replace the system-board and chassis assembly, as described in "Replacing the Tier 2 system-board and chassis assembly" on page 229.
CA00E800	Initialize RTAS	<ol style="list-style-type: none"> 1. Go to "Checkout procedure" on page 148. 2. Replace the system-board and chassis assembly, as described in "Replacing the Tier 2 system-board and chassis assembly" on page 229.
CA00E810	Initializing ioconfig pfds	<ol style="list-style-type: none"> 1. Go to "Checkout procedure" on page 148. 2. Replace the system-board and chassis assembly, as described in "Replacing the Tier 2 system-board and chassis assembly" on page 229.
CA00E820	Initializing lpevent	<ol style="list-style-type: none"> 1. Go to "Checkout procedure" on page 148. 2. Replace the system-board and chassis assembly, as described in "Replacing the Tier 2 system-board and chassis assembly" on page 229.
CA00E830	Initializing event scan	<ol style="list-style-type: none"> 1. Go to "Checkout procedure" on page 148. 2. Replace the system-board and chassis assembly, as described in "Replacing the Tier 2 system-board and chassis assembly" on page 229.
CA00E840	Initializing hot plug	<ol style="list-style-type: none"> 1. Go to "Checkout procedure" on page 148. 2. Replace the system-board and chassis assembly, as described in "Replacing the Tier 2 system-board and chassis assembly" on page 229.
CA00E843	Initializing interface/aix access	<ol style="list-style-type: none"> 1. Go to "Checkout procedure" on page 148. 2. Replace the system-board and chassis assembly, as described in "Replacing the Tier 2 system-board and chassis assembly" on page 229.

- If the system hangs on a progress code, follow the suggested actions in the order in which they are listed in the Action column until the problem is solved. If an action solves the problem, you can stop performing the remaining actions.
- See *Chapter 3, "Parts listing,"* on page 197 to determine which components are CRUs and which components are FRUs.

Progress code	Description	Action
CA00E850	Initializing dynamic reconfiguration	1. Go to "Checkout procedure" on page 148. 2. Replace the system-board and chassis assembly, as described in "Replacing the Tier 2 system-board and chassis assembly" on page 229.
CA00E860	Initializing sensors	1. Go to "Checkout procedure" on page 148. 2. Replace the system-board and chassis assembly, as described in "Replacing the Tier 2 system-board and chassis assembly" on page 229.
CA00E865	Initializing VPD	1. Go to "Checkout procedure" on page 148. 2. Replace the system-board and chassis assembly, as described in "Replacing the Tier 2 system-board and chassis assembly" on page 229.
CA00E870	Initializing pfd's memory manager	1. Go to "Checkout procedure" on page 148. 2. Replace the system-board and chassis assembly, as described in "Replacing the Tier 2 system-board and chassis assembly" on page 229.
CA00E875	Initializing rtas_last_error	1. Go to "Checkout procedure" on page 148. 2. Replace the system-board and chassis assembly, as described in "Replacing the Tier 2 system-board and chassis assembly" on page 229.
CA00E876	Initializing rtas_error_inject	1. Go to "Checkout procedure" on page 148. 2. Replace the system-board and chassis assembly, as described in "Replacing the Tier 2 system-board and chassis assembly" on page 229.
CA00E877	Initializing dump interface	1. Go to "Checkout procedure" on page 148. 2. Replace the system-board and chassis assembly, as described in "Replacing the Tier 2 system-board and chassis assembly" on page 229.
CA00E879	Initializing the platform-assisted kdump interface	1. Go to "Checkout procedure" on page 148. 2. Replace the system-board and chassis assembly, as described in "Replacing the Tier 2 system-board and chassis assembly" on page 229.
CA00E885	Initializing set-power-level	1. Go to "Checkout procedure" on page 148. 2. Replace the system-board and chassis assembly, as described in "Replacing the Tier 2 system-board and chassis assembly" on page 229.
CA00E886	Initializing exit2c	1. Go to "Checkout procedure" on page 148. 2. Replace the system-board and chassis assembly, as described in "Replacing the Tier 2 system-board and chassis assembly" on page 229.
CA00E887	Initialize gdata for activate_firmware	1. Go to "Checkout procedure" on page 148. 2. Replace the system-board and chassis assembly, as described in "Replacing the Tier 2 system-board and chassis assembly" on page 229.
CA00E890	Starting to initialize open firmware	1. Go to "Checkout procedure" on page 148. 2. Replace the system-board and chassis assembly, as described in "Replacing the Tier 2 system-board and chassis assembly" on page 229.

- If the system hangs on a progress code, follow the suggested actions in the order in which they are listed in the Action column until the problem is solved. If an action solves the problem, you can stop performing the remaining actions.
- See *Chapter 3, "Parts listing,"* on page 197 to determine which components are CRUs and which components are FRUs.

Progress code	Description	Action
CA00E891	Finished initializing open firmware	<ol style="list-style-type: none"> 1. Go to "Checkout procedure" on page 148. 2. Replace the system-board and chassis assembly, as described in "Replacing the Tier 2 system-board and chassis assembly" on page 229.
CA00EAA1	Probe PCI-PCI bridge bus	<ol style="list-style-type: none"> 1. Go to "Checkout procedure" on page 148. 2. Replace the system-board and chassis assembly, as described in "Replacing the Tier 2 system-board and chassis assembly" on page 229.
CA060203	An alias was modified or created	<ol style="list-style-type: none"> 1. Go to "Checkout procedure" on page 148. 2. Replace the system-board and chassis assembly, as described in "Replacing the Tier 2 system-board and chassis assembly" on page 229.
CA26ttss	Waiting for lpevent of type <i>tt</i> and subtype <i>ss</i> .	<ol style="list-style-type: none"> 1. Reboot the blade server. 2. If the problem persists: <ol style="list-style-type: none"> a. Go to "Checkout procedure" on page 148. b. Replace the system-board and chassis assembly, as described in "Replacing the Tier 2 system-board and chassis assembly" on page 229.
CA26FFFF	An extended item was required for lpevent to complete.	<ol style="list-style-type: none"> 1. Go to "Checkout procedure" on page 148. 2. Replace the system-board and chassis assembly, as described in "Replacing the Tier 2 system-board and chassis assembly" on page 229.
CA279001	The firmware update image contains an update module that is not already on the system.	<ol style="list-style-type: none"> 1. Look at the event log for a BA27xxxx error code to determine if a firmware installation error occurred. 2. If a firmware installation error did occur, resolve the problem. 3. Retry the firmware update. 4. If the problem persists: <ol style="list-style-type: none"> a. Go to "Checkout procedure" on page 148. b. Replace the system-board and chassis assembly, as described in "Replacing the Tier 2 system-board and chassis assembly" on page 229.

- If the system hangs on a progress code, follow the suggested actions in the order in which they are listed in the Action column until the problem is solved. If an action solves the problem, you can stop performing the remaining actions.
- See *Chapter 3, "Parts listing,"* on page 197 to determine which components are CRUs and which components are FRUs.

Progress code	Description	Action
CA2799FD	A firmware update module is being read.	<p>This checkpoint alternates in the control panel with CA2799FF.</p> <p>This pair of checkpoints might stay in the display for up to 30 minutes with no indication of activity other than the alternating codes. Do not assume that the system is hung until the alternation stops and only one of the checkpoints remains in the control panel for at least 30 minutes, with no other indication of activity.</p> <p>If the system is hung on this checkpoint, then CA2799FD and CA2799FF are not alternating and you must perform the following procedure:</p> <ol style="list-style-type: none"> 1. Shut down the blade server. 2. Restart it using the permanent boot image. 3. Reject the temporary image.
CA2799FF	A firmware update module is being written.	<p>This checkpoint alternates in the control panel with CA2799FD.</p> <p>This pair of checkpoints might stay in the display for up to 30 minutes with no indication of activity other than the alternating codes. Do not assume that the system is hung until the alternation stops and only one of the checkpoints remains in the control panel for at least 30 minutes, with no other indication of activity.</p> <p>If the system is hung on this checkpoint, then CA2799FD and CA2799FF are not alternating and you must perform the following procedure:</p> <ol style="list-style-type: none"> 1. Shut down the blade server. 2. Restart it using the permanent boot image. 3. Reject the temporary image.

2.4.2.6 D1001xxx to D1xx3FFF Service processor dump codes

D1xx service processor dump status codes indicate the cage or node ID that the dump component is processing, the node from which the hardware data is collected, and a counter that increments each time that the dump processor stores 4K of dump data.

Service processor dump status codes use the format, D1yy1xxx, where yy and xxx can be any number or letter.

The yy part of the code indicates the cage or node ID that the dump component is processing. The node varies depending on the node from which the hardware data is collected. The node is 0xFF when collecting the mainstore memory data.

The xxx part of the code is a counter that increments each time that the dump processor stores 4K of dump data.

Table 2-19 on page 101 lists the progress codes that might be displayed during the power-on self-test (POST), along with suggested actions to take if the system hangs on the progress code. Only when you experience a hang condition should you take any of the actions described for a progress code.

Table 2-19. D1001xxx to D1xx3FFF dump codes

Progress code	Description	Action
D1001xxx	Dump error data	<ol style="list-style-type: none"> 1. Go to "Checkout procedure" on page 148. 2. Replace the system-board and chassis assembly, as described in "Replacing the Tier 2 system-board and chassis assembly" on page 229.
D1011xxx	Dump sai_header	<ol style="list-style-type: none"> 1. Go to "Checkout procedure" on page 148. 2. Replace the system-board and chassis assembly, as described in "Replacing the Tier 2 system-board and chassis assembly" on page 229.
D101C00F	No power off to allow debugging for CPU controls	<ol style="list-style-type: none"> 1. Go to "Checkout procedure" on page 148. 2. Replace the system-board and chassis assembly, as described in "Replacing the Tier 2 system-board and chassis assembly" on page 229.
D1021xxx	Dump dump header directory	<ol style="list-style-type: none"> 1. Go to "Checkout procedure" on page 148. 2. Replace the system-board and chassis assembly, as described in "Replacing the Tier 2 system-board and chassis assembly" on page 229.
D1031xxx	Dump dump header fips header	<ol style="list-style-type: none"> 1. Go to "Checkout procedure" on page 148. 2. Replace the system-board and chassis assembly, as described in "Replacing the Tier 2 system-board and chassis assembly" on page 229.
D1041xxx	Dump dump header entry header	<ol style="list-style-type: none"> 1. Go to "Checkout procedure" on page 148. 2. Replace the system-board and chassis assembly, as described in "Replacing the Tier 2 system-board and chassis assembly" on page 229.

- If the system hangs on a progress code, follow the suggested actions in the order in which they are listed in the Action column until the problem is solved. If an action solves the problem, you can stop performing the remaining actions.
- See Chapter 3, "Parts listing," on page 197 to determine which components are CRUs and which components are FRUs.

- If the system hangs on a progress code, follow the suggested actions in the order in which they are listed in the Action column until the problem is solved. If an action solves the problem, you can stop performing the remaining actions.
- See *Chapter 3, "Parts listing,"* on page 197 to determine which components are CRUs and which components are FRUs.

Progress code	Description	Action
D1051xxx	Dump core file for failing component	1. Go to "Checkout procedure" on page 148. 2. Replace the system-board and chassis assembly, as described in "Replacing the Tier 2 system-board and chassis assembly" on page 229.
D1061xxx	Dump all NVRAM	1. Go to "Checkout procedure" on page 148. 2. Replace the system-board and chassis assembly, as described in "Replacing the Tier 2 system-board and chassis assembly" on page 229.
D1071xxx	Dump component trace for failing component	1. Go to "Checkout procedure" on page 148. 2. Replace the system-board and chassis assembly, as described in "Replacing the Tier 2 system-board and chassis assembly" on page 229.
D1081xxx	Dump component data from /opt/p0	1. Go to "Checkout procedure" on page 148. 2. Replace the system-board and chassis assembly, as described in "Replacing the Tier 2 system-board and chassis assembly" on page 229.
D1091xxx	Dump /opt/p1/**	1. Go to "Checkout procedure" on page 148. 2. Replace the system-board and chassis assembly, as described in "Replacing the Tier 2 system-board and chassis assembly" on page 229.
D1111xxx	Dump /opt/p0/*	1. Go to "Checkout procedure" on page 148. 2. Replace the system-board and chassis assembly, as described in "Replacing the Tier 2 system-board and chassis assembly" on page 229.
D1121xxx	Dump /opt/p1/*	1. Go to "Checkout procedure" on page 148. 2. Replace the system-board and chassis assembly, as described in "Replacing the Tier 2 system-board and chassis assembly" on page 229.
D1131xxx	Dump all traces	1. Go to "Checkout procedure" on page 148. 2. Replace the system-board and chassis assembly, as described in "Replacing the Tier 2 system-board and chassis assembly" on page 229.
D1141xxx	Dump code version	1. Go to "Checkout procedure" on page 148. 2. Replace the system-board and chassis assembly, as described in "Replacing the Tier 2 system-board and chassis assembly" on page 229.
D1151xxx	Dump all /opt/p3 except rtbl	1. Go to "Checkout procedure" on page 148. 2. Replace the system-board and chassis assembly, as described in "Replacing the Tier 2 system-board and chassis assembly" on page 229.
D1161xxx	Dump pddcustomize -r command	1. Go to "Checkout procedure" on page 148. 2. Replace the system-board and chassis assembly, as described in "Replacing the Tier 2 system-board and chassis assembly" on page 229.
D1171xxx	Dump registry -l command	1. Go to "Checkout procedure" on page 148. 2. Replace the system-board and chassis assembly, as described in "Replacing the Tier 2 system-board and chassis assembly" on page 229.

- If the system hangs on a progress code, follow the suggested actions in the order in which they are listed in the Action column until the problem is solved. If an action solves the problem, you can stop performing the remaining actions.
- See *Chapter 3, "Parts listing,"* on page 197 to determine which components are CRUs and which components are FRUs.

Progress code	Description	Action
D1181xxx	Dump all /core/core.* files	1. Go to "Checkout procedure" on page 148. 2. Replace the system-board and chassis assembly, as described in "Replacing the Tier 2 system-board and chassis assembly" on page 229.
D1191xxx	Dump BDMP component trace (after dump if enough place)	1. Go to "Checkout procedure" on page 148. 2. Replace the system-board and chassis assembly, as described in "Replacing the Tier 2 system-board and chassis assembly" on page 229.
D11A1xxx	Dump any state information before dumping starts	1. Go to "Checkout procedure" on page 148. 2. Replace the system-board and chassis assembly, as described in "Replacing the Tier 2 system-board and chassis assembly" on page 229.
D11B1xxx	Dump /proc filesystem	1. Go to "Checkout procedure" on page 148. 2. Replace the system-board and chassis assembly, as described in "Replacing the Tier 2 system-board and chassis assembly" on page 229.
D11C1xxx	Dump mounted filesystem statistics	1. Go to "Checkout procedure" on page 148. 2. Replace the system-board and chassis assembly, as described in "Replacing the Tier 2 system-board and chassis assembly" on page 229.
D11D1xxx	Dump environment	1. Go to "Checkout procedure" on page 148. 2. Replace the system-board and chassis assembly, as described in "Replacing the Tier 2 system-board and chassis assembly" on page 229.
D1231xxx	Dump update dump headers	1. Go to "Checkout procedure" on page 148. 2. Replace the system-board and chassis assembly, as described in "Replacing the Tier 2 system-board and chassis assembly" on page 229.
D1241xxx	Dump CRC1 calculation off	1. Go to "Checkout procedure" on page 148. 2. Replace the system-board and chassis assembly, as described in "Replacing the Tier 2 system-board and chassis assembly" on page 229.
D1251xxx	Dump CRC1 calculation on	1. Go to "Checkout procedure" on page 148. 2. Replace the system-board and chassis assembly, as described in "Replacing the Tier 2 system-board and chassis assembly" on page 229.
D1261xxx	Dump CRC2 calculation off	1. Go to "Checkout procedure" on page 148. 2. Replace the system-board and chassis assembly, as described in "Replacing the Tier 2 system-board and chassis assembly" on page 229.
D1271xxx	Dump CRC2 calculation on	1. Go to "Checkout procedure" on page 148. 2. Replace the system-board and chassis assembly, as described in "Replacing the Tier 2 system-board and chassis assembly" on page 229.
D1281xxx	Dump output the calculated CRC1 (dump header)	1. Go to "Checkout procedure" on page 148. 2. Replace the system-board and chassis assembly, as described in "Replacing the Tier 2 system-board and chassis assembly" on page 229.

- If the system hangs on a progress code, follow the suggested actions in the order in which they are listed in the Action column until the problem is solved. If an action solves the problem, you can stop performing the remaining actions.
- See *Chapter 3, "Parts listing,"* on page 197 to determine which components are CRUs and which components are FRUs.

Progress code	Description	Action
D1291xxx	Dump output the calculated CRC2 (data and data header)	1. Go to "Checkout procedure" on page 148. 2. Replace the system-board and chassis assembly, as described in "Replacing the Tier 2 system-board and chassis assembly" on page 229.
D12A1xxx	Jump to the position in dump directly after CRC1	1. Go to "Checkout procedure" on page 148. 2. Replace the system-board and chassis assembly, as described in "Replacing the Tier 2 system-board and chassis assembly" on page 229.
D12B1xxx	Initialize the headers dump time and serial numbers	1. Go to "Checkout procedure" on page 148. 2. Replace the system-board and chassis assembly, as described in "Replacing the Tier 2 system-board and chassis assembly" on page 229.
D12C1xxx	Display final SRC to panel	1. Go to "Checkout procedure" on page 148. 2. Replace the system-board and chassis assembly, as described in "Replacing the Tier 2 system-board and chassis assembly" on page 229.
D12D1xxx	Rmove /core/core.app.time.pid	1. Go to "Checkout procedure" on page 148. 2. Replace the system-board and chassis assembly, as described in "Replacing the Tier 2 system-board and chassis assembly" on page 229.
D12E1xxx	Remove /core/core.*	1. Go to "Checkout procedure" on page 148. 2. Replace the system-board and chassis assembly, as described in "Replacing the Tier 2 system-board and chassis assembly" on page 229.
D12F1xxx	Display beginning SRC to panel	1. Go to "Checkout procedure" on page 148. 2. Replace the system-board and chassis assembly, as described in "Replacing the Tier 2 system-board and chassis assembly" on page 229.
D1301xxx	Turn off error log capture into dump	1. Go to "Checkout procedure" on page 148. 2. Replace the system-board and chassis assembly, as described in "Replacing the Tier 2 system-board and chassis assembly" on page 229.
D1311xxx	Turn on error log capture into dump	1. Go to "Checkout procedure" on page 148. 2. Replace the system-board and chassis assembly, as described in "Replacing the Tier 2 system-board and chassis assembly" on page 229.
D1321xxx	Store information about existing core files	1. Go to "Checkout procedure" on page 148. 2. Replace the system-board and chassis assembly, as described in "Replacing the Tier 2 system-board and chassis assembly" on page 229.
D1381xxx	Invalidate the dump	1. Go to "Checkout procedure" on page 148. 2. Replace the system-board and chassis assembly, as described in "Replacing the Tier 2 system-board and chassis assembly" on page 229.
D1391xxx	Check for valid dump sequence	1. Go to "Checkout procedure" on page 148. 2. Replace the system-board and chassis assembly, as described in "Replacing the Tier 2 system-board and chassis assembly" on page 229.

<ul style="list-style-type: none"> If the system hangs on a progress code, follow the suggested actions in the order in which they are listed in the Action column until the problem is solved. If an action solves the problem, you can stop performing the remaining actions. See <i>Chapter 3, "Parts listing,"</i> on page 197 to determine which components are CRUs and which components are FRUs. 		
Progress code	Description	Action
D13A1xxx	Get dump identity sequence	<ol style="list-style-type: none"> Go to "Checkout procedure" on page 148. Replace the system-board and chassis assembly, as described in "Replacing the Tier 2 system-board and chassis assembly" on page 229.
D13B1xxx	Get dump length sequence	<ol style="list-style-type: none"> Go to "Checkout procedure" on page 148. Replace the system-board and chassis assembly, as described in "Replacing the Tier 2 system-board and chassis assembly" on page 229.
D1FF1xxx	Dump complete	<ol style="list-style-type: none"> Go to "Checkout procedure" on page 148. Replace the system-board and chassis assembly, as described in "Replacing the Tier 2 system-board and chassis assembly" on page 229.
D1xx3000 - D1xx3FFF	Platform dump status codes are described in "D1xx3y01 to D1xx3yF2 Service processor dump codes:" on page 105	

2.4.2.7 D1xx3y01 to D1xx3yF2 Service processor dump codes:

These D1xx3yxx service processor dump codes use the format: D1xx3yzz, where xx indicates the cage or node ID that the dump component is processing, y increments from 0 to F to indicate that the system is not hung, and zz indicates the command being processed.

Table 2-20 lists the progress codes that might be displayed during the power-on self-test (POST), along with suggested actions to take if the system hangs on the progress code. Only when you experience a hang condition should you take any of the actions described for a progress code.

Table 2-20. D1xx3y01 to D1xx3yF2 checkpoints

<ul style="list-style-type: none"> If the system hangs on a progress code, follow the suggested actions in the order in which they are listed in the Action column until the problem is solved. If an action solves the problem, you can stop performing the remaining actions. See <i>Chapter 3, "Parts listing,"</i> on page 197 to determine which components are CRUs and which components are FRUs. 		
Progress code	Description (Command Being Processed)	Action
D1xx3y01	Get SCOM	<ol style="list-style-type: none"> Go to "Checkout procedure" on page 148. Replace the system-board and chassis assembly, as described in "Replacing the Tier 2 system-board and chassis assembly" on page 229.
D1xx3y02	Get scan ring	<ol style="list-style-type: none"> Go to "Checkout procedure" on page 148. Replace the system-board and chassis assembly, as described in "Replacing the Tier 2 system-board and chassis assembly" on page 229.

- If the system hangs on a progress code, follow the suggested actions in the order in which they are listed in the Action column until the problem is solved. If an action solves the problem, you can stop performing the remaining actions.
- See *Chapter 3, "Parts listing,"* on page 197 to determine which components are CRUs and which components are FRUs.

Progress code	Description (Command Being Processed)	Action
D1xx3y03	Get array values	1. Go to "Checkout procedure" on page 148. 2. Replace the system-board and chassis assembly, as described in "Replacing the Tier 2 system-board and chassis assembly" on page 229.
D1xx3y04	Stop the clocks	1. Go to "Checkout procedure" on page 148. 2. Replace the system-board and chassis assembly, as described in "Replacing the Tier 2 system-board and chassis assembly" on page 229.
D1xx3y05	Flush the cache	1. Go to "Checkout procedure" on page 148. 2. Replace the system-board and chassis assembly, as described in "Replacing the Tier 2 system-board and chassis assembly" on page 229.
D1xx3y06	Get CFAM	1. Go to "Checkout procedure" on page 148. 2. Replace the system-board and chassis assembly, as described in "Replacing the Tier 2 system-board and chassis assembly" on page 229.
D1xx3y07	Put SCOM	1. Go to "Checkout procedure" on page 148. 2. Replace the system-board and chassis assembly, as described in "Replacing the Tier 2 system-board and chassis assembly" on page 229.
D1xx3y08	Send command	1. Go to "Checkout procedure" on page 148. 2. Replace the system-board and chassis assembly, as described in "Replacing the Tier 2 system-board and chassis assembly" on page 229.
D1xx3y09	Get optimized cache	1. Go to "Checkout procedure" on page 148. 2. Replace the system-board and chassis assembly, as described in "Replacing the Tier 2 system-board and chassis assembly" on page 229.
D1xx3y0A	Get general purpose (GP) register	1. Go to "Checkout procedure" on page 148. 2. Replace the system-board and chassis assembly, as described in "Replacing the Tier 2 system-board and chassis assembly" on page 229.
D1xx3y0B	Processor clean-up	1. Go to "Checkout procedure" on page 148. 2. Replace the system-board and chassis assembly, as described in "Replacing the Tier 2 system-board and chassis assembly" on page 229.
D1xx3y0C	Get JTAG register	1. Go to "Checkout procedure" on page 148. 2. Replace the system-board and chassis assembly, as described in "Replacing the Tier 2 system-board and chassis assembly" on page 229.
D1xx3y0D	Stop clocks without quiescing	1. Go to "Checkout procedure" on page 148. 2. Replace the system-board and chassis assembly, as described in "Replacing the Tier 2 system-board and chassis assembly" on page 229.
D1xx3yF0	Memory collection set-up	1. Go to "Checkout procedure" on page 148. 2. Replace the system-board and chassis assembly, as described in "Replacing the Tier 2 system-board and chassis assembly" on page 229.

<ul style="list-style-type: none"> If the system hangs on a progress code, follow the suggested actions in the order in which they are listed in the Action column until the problem is solved. If an action solves the problem, you can stop performing the remaining actions. See <i>Chapter 3, "Parts listing,"</i> on page 197 to determine which components are CRUs and which components are FRUs. 		
Progress code	Description (Command Being Processed)	Action
D1xx3yF1	Memory collection DMA step	<ol style="list-style-type: none"> Go to "Checkout procedure" on page 148. Replace the system-board and chassis assembly, as described in "Replacing the Tier 2 system-board and chassis assembly" on page 229.
D1xx3yF2	Memory collection cleanup	<ol style="list-style-type: none"> Go to "Checkout procedure" on page 148. Replace the system-board and chassis assembly, as described in "Replacing the Tier 2 system-board and chassis assembly" on page 229.

2.4.2.8 D1xx900C to D1xxC003 Service processor power-off checkpoints

These D1xx service processor power-off status codes offer information about the status of the service processor during a power-off operation.

Table 2-21 lists the progress codes that might be displayed during the power-on self-test (POST), along with suggested actions to take if the system hangs on the progress code. Only when you experience a hang condition should you take any of the actions described for a progress code.

Table 2-21. D1xx900C to D1xxC003 checkpoints

<ul style="list-style-type: none"> If the system hangs on a progress code, follow the suggested actions in the order in which they are listed in the Action column until the problem is solved. If an action solves the problem, you can stop performing the remaining actions. See <i>Chapter 3, "Parts listing,"</i> on page 197 to determine which components are CRUs and which components are FRUs. 		
Progress code	Description (Command Being Processed)	Action
D1xx900C	Breakpoint set in CPU controls has been hit	<ol style="list-style-type: none"> Go to "Checkout procedure" on page 148. Replace the system-board and chassis assembly, as described in "Replacing the Tier 2 system-board and chassis assembly" on page 229.
D1xxB0FF	Request to initiate power-off program has been sent	<ol style="list-style-type: none"> Go to "Checkout procedure" on page 148. Replace the system-board and chassis assembly, as described in "Replacing the Tier 2 system-board and chassis assembly" on page 229.
D1xxC000	Indicates a message is ready to send to the hypervisor to power off	<ol style="list-style-type: none"> Go to "Checkout procedure" on page 148. Replace the system-board and chassis assembly, as described in "Replacing the Tier 2 system-board and chassis assembly" on page 229.
D1xxC001	Waiting for the hypervisor to acknowledge the delayed power off notification	<ol style="list-style-type: none"> Go to "Checkout procedure" on page 148. Replace the system-board and chassis assembly, as described in "Replacing the Tier 2 system-board and chassis assembly" on page 229.

- If the system hangs on a progress code, follow the suggested actions in the order in which they are listed in the Action column until the problem is solved. If an action solves the problem, you can stop performing the remaining actions.
- See *Chapter 3, "Parts listing,"* on page 197 to determine which components are CRUs and which components are FRUs.

Progress code	Description (Command Being Processed)	Action
D1xxC002	Waiting for the hypervisor to send the power off message	<ol style="list-style-type: none"> 1. Go to "<i>Checkout procedure</i>" on page 148. 2. Replace the system-board and chassis assembly, as described in "<i>Replacing the Tier 2 system-board and chassis assembly</i>" on page 229.
D1xxC003	Hypervisor handshaking is complete	<ol style="list-style-type: none"> 1. Go to "<i>Checkout procedure</i>" on page 148. 2. Replace the system-board and chassis assembly, as described in "<i>Replacing the Tier 2 system-board and chassis assembly</i>" on page 229.

2.4.3 Service request numbers (SRNs)

Service request numbers (SRNs) are error codes that the operating system generates. The codes have three digits, a hyphen, and three or four digits after the hyphen. SRNs can be viewed using the AIX diagnostics or the Linux service aid “diagela” if it is installed.

Note The “diagela” service aid is part of the Linux service aids for hardware diagnostics. The service aids are separate from the operating system.

2.4.3.1 Using the SRN tables

The service request number (SRN) list is in numerical sequence. The failing function codes (FFCs) are provided to aid in locating a failing component.

1. Look up a service request number when you see an error code with a hyphen. The SRN is in the first column of the SRN table in numerical order. The SRN might have an associated FFC number. Possible FFC values for SRNs are displayed in the second column of the table. FFC numbers might be the first three digits of the SRN or the last three digits, or might not be in the SRC. The third column describes the problem and an action to take to try to fix the problem. The description also includes how to find the FFC number for an SRC if one exists.
2. See “*Failing function codes 151 through 2D02*” on page 144 for a description of each FFC value.
3. If the SRN does not appear in the table, see “*Solving undetermined problems*” on page 194.
4. After replacing a component, verify the replacement part and perform a log-repair action using the AIX diagnostics.

2.4.3.2 101-711 through FFC-725 SRNs

AIX might generate service request numbers (SRNs) from 101-711 to FFC-725.

Replace any parts in the order that the codes are listed in *Table 2-22*.

Note An x in the following SRNs represents a digit or character that might have any value.

Table 2-22. 101-711 through FFC-725 SRNs

SRN	FFC	Description and Action
101-711 to 101-726	711 to 726	The system hung while trying to configure an unknown resource. <ol style="list-style-type: none"> 1. Run the stand-alone diagnostics problem determination procedure. 2. If the problem remains, refer to "Failing function codes 151 through 2D02" on page 144 to find the FFC that matches the last three digits of the SRN. 3. Suspect the device adapter or device itself.
101-888	210 227	The system does not IPL. Go to "Performing the checkout procedure" on page 149 or undetermined problem procedure.
101-2020		The system hung while trying to configure the InfiniBand Communication Manager. This problem may be attributed to software. Report this problem to the AIX Support Center.
101-2021		The system hung while trying to configure the InfiniBand TCP/IP Interface. This problem may be attributed to software. Report this problem to the AIX Support Center.
101-xxxx	xxxx	The system hung while configuring a resource. The last three or four digits after the dash (-) identify the failing function code for the resource being configured. Go to undetermined problem procedure.
103-151	151	The time-of-day battery failed. <ol style="list-style-type: none"> 1. Go to "Removing the battery" on page 224 to start the battery replacement procedure. 2. Go to "Installing the battery" on page 225 to complete the procedure.
109-200		The system crashed while you were running it. <ol style="list-style-type: none"> 1. Go to "Performing the checkout procedure" on page 149 2. If the 8-digit error and location codes were NOT reported, run AIX diagnostics in problem determination procedure and record and report the 8-digit error and location codes for this SRN.
110-101		The diagnostics did not detect an installed resource. If this SRN appeared when running concurrent diagnostics, then run concurrent diagnostics using the diag -a command.
110-921 to 110-926	812 xxx	The system halted while diagnostics were executing. Go to "Performing the checkout procedure" on page 149 or problem resolution. Note: xxx corresponds to the last three digits of the SRN.
110-935	812	The system halted while diagnostics were executing. Use the problem determination procedure.
110-xxxx	xxxx 221	The system halted while diagnostics were executing. Note: xxxx corresponds to the last three or four digits of the SRN following the dash (-). <ol style="list-style-type: none"> 1. If your 110 SRN is not listed, substitute the last three or four digits of the SRN for xxxx and go to "Failing function codes 151 through 2D02" on page 144 to identify the failing feature. 2. Run stand-alone diagnostics and the problem determination procedure for your operating system.
111-107		A machine check occurred. Go to "Performing the checkout procedure" on page 149
111-108		An encoded SRN was displayed. Go to "Performing the checkout procedure" on page 149
111-121		There is a display problem. Go to "Performing the checkout procedure" on page 149

SRN	FFC	Description and Action
111-78C	227	PCI adapter I/O bus problem. Go to "Performing the checkout procedure" on page 149. Perform "Solving undetermined problems" on page 194.
111-999	210	System does not perform a soft reset. Go to "Performing the checkout procedure" on page 149
650-xxx	650	Disk drive configuration failed. <ol style="list-style-type: none"> 1. Check the management-module event log. If an error was recorded by the system, see "POST progress codes (checkpoints)" on page 71. 2. Replace any parts reported by the diagnostic program. 3. Update the disk drive firmware. 4. Troubleshoot the disk drive. 5. Replace the system-board and chassis assembly.
651-xxx		The CEC reported a non-critical error. <ol style="list-style-type: none"> 1. Schedule deferred maintenance. 2. Refer to the entry MAP in this system unit system service guide, with the 8-digit error and location codes, for the necessary repair action. 3. If the 8-digit error and location codes were NOT reported, then run diagnostics in problem determination mode and record and report the 8-digit error and location codes for this SRN.
651-140	221	Display Character test failed. Note: Diagnostic will provide this SRN but there is no action to be taken. Do not perform operator panel test from diagnostics.
651-151	152 2E2	Sensor indicates a voltage is outside the normal range. Go to "Performing the checkout procedure" on page 149.
651-152	2E1	Sensor indicates an abnormally high internal temperature. Verify that: <ol style="list-style-type: none"> 1. The room ambient temperature is within the system operating environment. 2. There is unrestricted air flow around the system. 3. All system covers are closed. 4. Verify that all fans in the Bull Blade Chassis - Enterprise are operating correctly.
651-159	210	Sensor indicates a FRU has failed. Use the failing function codes, use the physical location code(s) from the diagnostic problem report screen to determine the FRUs.
651-161	2E2	Sensor indicates a voltage is outside the normal range. Go to "Performing the checkout procedure" on page 149.
651-162	2E1	Sensor indicates an abnormally high internal temperature. Verify that: <ol style="list-style-type: none"> 1. The room ambient temperature is within the system operating environment. 2. There is unrestricted air flow around the system. 3. There are no fan or blower failures in the Bull Blade Chassis - Enterprise. If the problem remains, check the management-module event log for possible causes of overheating.
651-169		Sensor indicates a FRU has failed. Go to "Performing the checkout procedure" on page 149.
651-170		Sensor status not available. Go to "Performing the checkout procedure" on page 149.
651-171		Sensor status not available. Go to "Performing the checkout procedure" on page 149.
651-600		Uncorrectable memory or unsupported memory. <ol style="list-style-type: none"> 1. Examine the memory modules and determine if they are supported types. 2. If the modules are supported, then reseal the DIMMs. 3. Replace the appropriate memory modules.
651-601		Missing or bad memory. If the installed memory matches the reported memory size, then replace the memory; otherwise, add the missing memory.
651-602	2C7	Failed memory module. Go to "Performing the checkout procedure" on page 149.
651-603	2C6 2C7	Failed memory module. Go to "Performing the checkout procedure" on page 149.

SRN	FFC	Description and Action
651-605	2C6	Memory module has no matched pair. The most probable failure is the memory module paired with the memory module identified by the location code. 1. Examine the memory modules and determine if they are supported types. 2. If the modules are supported, then reseal the DIMMs. 3. Replace the appropriate memory modules.
651-608	D01	Bad L2 cache. Go to "Performing the checkout procedure" on page 149.
651-609	D01	Missing L2 cache. Go to "Performing the checkout procedure" on page 149.
651-610	210	CPU internal error. Go to "Performing the checkout procedure" on page 149.
651-611	210	CPU internal cache controller error. Go to "Performing the checkout procedure" on page 149.
651-612	D01	External cache ECC single-bit error. Go to "Performing the checkout procedure" on page 149.
651-613	D01	External cache ECC single-bit error. Go to "Performing the checkout procedure" on page 149.
651-614	214	System bus time-out error. Go to "Performing the checkout procedure" on page 149.
651-615	292	Time-out error waiting for I/O. Go to "Performing the checkout procedure" on page 149.
651-619		Error log analysis indicates an error detected by the CPU. Use failing function codes and the physical location codes from the diagnostic problem report screen to determine the FRUs.
651-621	2C6	ECC correctable error. Go to "Performing the checkout procedure" on page 149.
651-623	2C6	Correctable error threshold exceeded. Go to "Performing the checkout procedure" on page 149.
651-624	214	Memory control subsystem internal error. Go to "Performing the checkout procedure" on page 149.
651-625	214	Memory address error (invalid address or access attempt). Go to "Performing the checkout procedure" on page 149.
651-626	214	Memory data error (bad data going to memory). Go to "Performing the checkout procedure" on page 149.
651-627	214	System bus time-out error. Go to "Performing the checkout procedure" on page 149.
651-628	210	System bus protocol/transfer error. Go to "Performing the checkout procedure" on page 149.
651-629	210	Error log analysis indicates an error detected by the memory controller. Go to "Performing the checkout procedure" on page 149.
651-632	308	Internal device error. Go to "Performing the checkout procedure" on page 149.
651-639	210	Error log analysis indicates an error detected by the I/O. Using the problem determination procedure, failing function codes, and the physical location codes from the diagnostic problem report to determine the FRUs.
651-640	2D5	I/O general bus error. Go to "Performing the checkout procedure" on page 149.
651-641	2D6	Secondary I/O general bus error. Go to "Performing the checkout procedure" on page 149.
651-642	2D3	Internal service processor memory error. Go to "Performing the checkout procedure" on page 149.
651-643	2D3	Internal service processor firmware error. Go to "Performing the checkout procedure" on page 149.
651-644	2D3	Other internal service processor hardware error. Go to "Performing the checkout procedure" on page 149.
651-659	2CD	ECC correctable error. Go to "Performing the checkout procedure" on page 149.
651-65A	2CE	ECC correctable error. Go to "Performing the checkout procedure" on page 149.
651-65B	2CC	ECC correctable error. Go to "Performing the checkout procedure" on page 149.
651-664	302	Correctable error threshold exceeded. Go to "Performing the checkout procedure" on page 149.

SRN	FFC	Description and Action
651-665	303	Correctable error threshold exceeded. Go to "Performing the checkout procedure" on page 149.
651-666	304	Correctable error threshold exceeded. Go to "Performing the checkout procedure" on page 149.
651-669	2CD	Correctable error threshold exceeded. Go to "Performing the checkout procedure" on page 149.
651-66A	2CE	Correctable error threshold exceeded. Go to "Performing the checkout procedure" on page 149.
651-66B	2CC	Correctable error threshold exceeded. Go to "Performing the checkout procedure" on page 149.
651-674	302	Failed memory module. Go to "Performing the checkout procedure" on page 149.
651-675	303	Failed memory module. Go to "Performing the checkout procedure" on page 149.
651-676	304	Failed memory module. Go to "Performing the checkout procedure" on page 149.
651-679	2CD	Failed memory module. Go to "Performing the checkout procedure" on page 149.
651-67A	2CE	Failed memory module. Go to "Performing the checkout procedure" on page 149.
651-67B	2CC	Failed memory module. Go to "Performing the checkout procedure" on page 149.
651-685	303	Memory module has no matched pair. The most probable failure is the memory module paired with the memory module identified by the location code. Go to "Performing the checkout procedure" on page 149.
651-686	304	Memory module has no matched pair. The most probable failure is the memory module paired with the memory module identified by the location code. Go to "Performing the checkout procedure" on page 149.
651-710	214 2C4	System bus parity error. Go to "Performing the checkout procedure" on page 149.
651-711	210 2C4	System bus parity error. Go to "Performing the checkout procedure" on page 149.
651-712	214	System bus parity error. Go to "Performing the checkout procedure" on page 149.
651-713	214	System bus protocol/transfer error. Go to "Performing the checkout procedure" on page 149.
651-714	2C4	System bus protocol/transfer error. Go to "Performing the checkout procedure" on page 149.
651-715	2C4	System bus protocol/transfer error. Go to "Performing the checkout procedure" on page 149.
651-720	2C7 214	Uncorrectable memory error. Go to "Performing the checkout procedure" on page 149.
651-721	2C6 2C7 214	Uncorrectable memory error. Go to "Performing the checkout procedure" on page 149.
651-722	2C4	System bus parity error. Go to "Performing the checkout procedure" on page 149.
651-723	2C4	System bus protocol/transfer error. Go to "Performing the checkout procedure" on page 149.
651-724	292	I/O host bridge time-out error. Go to "Performing the checkout procedure" on page 149.
651-725	292	I/O host bridge address/data parity error. Go to "Performing the checkout procedure" on page 149.
651-726	Software	I/O host bridge timeout caused by software. This error is caused by a software or operating system attempt to access an invalid memory address. Go to "Performing the checkout procedure" on page 149.
651-731	2C8	Intermediate or system bus address parity error. Go to "Performing the checkout procedure" on page 149.
651-732	2C8	Intermediate or system bus data parity error. Go to "Performing the checkout procedure" on page 149.
651-733	2C8	Intermediate or system bus address parity error. Go to "Performing the checkout procedure" on page 149.
651-734	292	Intermediate or system bus data parity error. Go to "Performing the checkout procedure" on page 149.
651-735	292	Intermediate or system bus time-out error. Go to "Performing the checkout procedure" on page 149.

SRN	FFC	Description and Action
651-736	292	Intermediate or system bus time-out error. Go to "Performing the checkout procedure" on page 149.
651-740	2D3	Note: Ensure that the system IPLROS and service processor are at the latest firmware level before removing any parts from the system.
651-741	2D3	Service processor error accessing special registers. Go to "Performing the checkout procedure" on page 149.
651-742	2D3	Service processor reports unknown communication error. Go to "Performing the checkout procedure" on page 149.
651-743	2D5	Service processor error accessing Vital Product Data EEPROM. Go to "Performing the checkout procedure" on page 149.
651-745	2D9	Service processor error accessing power controller. Go to "Performing the checkout procedure" on page 149.
651-746	2D4	Service processor error accessing fan sensor. Go to "Performing the checkout procedure" on page 149.
651-747	2D5	Service processor error accessing thermal sensor. Go to "Performing the checkout procedure" on page 149.
651-748	2E2	Service processor error accessing voltage sensor. Go to "Performing the checkout procedure" on page 149.
651-750	2D4	Service processor detected NVRAM error. Go to "Performing the checkout procedure" on page 149.
651-751	2D4	Service processor error accessing real-time clock/time-of-day clock. Go to "Performing the checkout procedure" on page 149.
651-752	2D4	Service processor error accessing JTAG/COP controller/hardware. Go to "Performing the checkout procedure" on page 149.
651-753	151 2D4	Service processor detects loss of voltage from the time-of-day clock backup battery. Go to "Performing the checkout procedure" on page 149.
651-770	292	Intermediate or system bus address parity error. Go to "Performing the checkout procedure" on page 149.
651-771	292	Intermediate or system bus data parity error. Go to "Performing the checkout procedure" on page 149.
651-772	292	Intermediate or system bus time-out error. Go to "Performing the checkout procedure" on page 149.
651-773	227	Intermediate or system bus data parity error. Go to "Performing the checkout procedure" on page 149.
651-780	2C7 214	Uncorrectable memory error. Go to "Performing the checkout procedure" on page 149.
651-781	2C7 214	Uncorrectable memory error. Go to "Performing the checkout procedure" on page 149.
651-784	302 214	Uncorrectable memory error. Go to "Performing the checkout procedure" on page 149.
651-785	303 214	Uncorrectable memory error. Go to "Performing the checkout procedure" on page 149.
651-786	304 214	Uncorrectable memory error. Go to "Performing the checkout procedure" on page 149.
651-789	2CD 214	Uncorrectable memory error. Go to "Performing the checkout procedure" on page 149.
651-78A	2CE 214	Uncorrectable memory error. Go to "Performing the checkout procedure" on page 149.
651-78B	2CC 214	Uncorrectable memory error. Go to "Performing the checkout procedure" on page 149.
651-809		Power fault warning due to unspecified cause. Go to "Performing the checkout procedure" on page 149.
651-810	2E2	Over-voltage condition was detected. Do the following procedure before replacing any FRUs: 1. Shut the system down. 2. Visually inspect the power cables and reseal the connectors. 3. Run the following command <code>diag -Avd sysplanar0</code> . When the Resource Repair Action menu displays, select sysplanar0 .

SRN	FFC	Description and Action
651-811	2E2	Under voltage condition was detected Do the following procedure before replacing any FRUs: 1. Shut the system down. 2. Visually inspect the power cables and reseat the connectors. 3. Run the following command <code>diag -Avd sysplanar0</code> . When the Resource Repair Action menu displays, select <code>sysplanar0</code> .
651-813		System shutdown due to loss of ac power to the site. System resumed normal operation, no action required.
651-818		Power fault due to manual activation of power-off request. Resume normal operation.
651-820	2E1	An over-temperature condition was detected. 1. Make sure that: v The room ambient temperature is within the system operating environment v There is unrestricted air flow around the system 2. Replace the system-board and chassis assembly.
651-821	2E1	System shutdown due to an over maximum temperature condition being reached. 1. Make sure that: v The room ambient temperature is within the system operating environment v There is unrestricted air flow around the system 2. Replace the system-board and chassis assembly.
651-822	2E1	System shutdown due to over temperature condition and fan failure. Use the physical FRU location(s) as the probable cause(s). Use the physical location codes to replace the FRUs that are identified on the diagnostics problem report screen.
651-831	2E2	Sensor detected a voltage outside of the normal range. Go to <i>"Performing the checkout procedure"</i> on page 149.
651-832	G2E1	Sensor detected an abnormally high internal temperature. Make sure that: 1. The room ambient temperature is within the system operating environment. 2. There is unrestricted air flow around the system. 3. There are no fan failures.
651-841	152 2E2	Sensor detected a voltage outside of the normal range. Go to <i>"Performing the checkout procedure"</i> on page 149.
651-842	2E1	Sensor detected an abnormally high internal temperature. Make sure that: 1. The room ambient temperature is within the system operating environment. 2. There is unrestricted air flow around the system. 3. All system covers are closed. 4. There are no fan failures.
651-90x		Platform-specific error. Call your support center.
652-600		A non-critical error has been detected: uncorrectable memory or unsupported memory. Schedule deferred maintenance. Examine the memory modules and determine if they are supported types. If the modules are supported, then replace the appropriate memory modules.
652-610	210	A non-critical error has been detected: CPU internal error. Schedule deferred maintenance. Go to <i>"Performing the checkout procedure"</i> on page 149.
652-611	210	A non-critical error has been detected: CPU internal cache or cache controller error. Schedule deferred maintenance. Go to <i>"Performing the checkout procedure"</i> on page 149.
652-612	D01	A non-critical error has been detected: external cache parity or multi-bit ECC error. Schedule deferred maintenance. Go to <i>"Performing the checkout procedure"</i> on page 149.
652-613	D01	A non-critical error has been detected: external cache ECC single-bit error. Schedule deferred maintenance. Go to <i>"Performing the checkout procedure"</i> on page 149.
652-623	2C6	A non-critical error has been detected: correctable error threshold exceeded. Schedule deferred maintenance. Go to <i>"Performing the checkout procedure"</i> on page 149.
652-630	307	A non-critical error has been detected: I/O expansion bus parity error. Schedule deferred maintenance. Go to <i>"Performing the checkout procedure"</i> on page 149.

SRN	FFC	Description and Action
652-631	307	A non-critical error has been detected: I/O expansion bus time-out error. Schedule deferred maintenance. Go to "Performing the checkout procedure" on page 149.
652-632	307	A non-critical error has been detected: I/O expansion bus connection failure. Schedule deferred maintenance. Go to "Performing the checkout procedure" on page 149.
652-633	307	A non-critical error has been detected: I/O expansion unit not in an operating state. Schedule deferred maintenance. Go to "Performing the checkout procedure" on page 149.
652-634	307	A non-critical error has been detected: internal device error. Schedule deferred maintenance. Go to "Performing the checkout procedure" on page 149.
652-664	302	A non-critical error has been detected: correctable error threshold exceeded. Schedule deferred maintenance. Go to "Performing the checkout procedure" on page 149.
652-665	303	A non-critical error has been detected: correctable error threshold exceeded. Schedule deferred maintenance. Go to "Performing the checkout procedure" on page 149.
652-666	304	A non-critical error has been detected: correctable error threshold exceeded. Schedule deferred maintenance. Go to "Performing the checkout procedure" on page 149.
652-669	2CD	A non-critical error has been detected: correctable error threshold exceeded. Schedule deferred G maintenance. Go to "Performing the checkout procedure" on page 149.
652-66A	2CE	A non-critical error has been detected: correctable error threshold exceeded. Schedule deferred maintenance. Go to "Performing the checkout procedure" on page 149.
652-66B	2CC	A non-critical error has been detected: correctable error threshold exceeded. Schedule deferred maintenance. Go to "Performing the checkout procedure" on page 149.
652-731	2C8	A non-critical error has been detected: intermediate or system bus address parity error. Schedule deferred maintenance. Go to "Performing the checkout procedure" on page 149.
652-732	2C8	A non-critical error has been detected: intermediate or system bus data parity error. Schedule deferred maintenance. Go to "Performing the checkout procedure" on page 149.
652-733	2C8 292	A non-critical error has been detected: intermediate or system bus address parity error. Schedule deferred maintenance. Go to "Performing the checkout procedure" on page 149.
652-734	2C8 292	A non-critical error has been detected: intermediate or system bus data parity error. Schedule deferred maintenance. Go to "Performing the checkout procedure" on page 149.
652-735	2D2 292	A non-critical error has been detected: intermediate or system bus time-out error. Schedule deferred maintenance. Go to "Performing the checkout procedure" on page 149.
652-736	2D2 292	A non-critical error has been detected: intermediate or system bus time-out error. Schedule deferred maintenance. Go to "Performing the checkout procedure" on page 149.
652-770	2C8 292	A non-critical error has been detected: intermediate system bus address parity error. Schedule deferred maintenance. Go to "Performing the checkout procedure" on page 149.
652-771	2C8 292	A non-critical error has been detected: intermediate or system bus data parity error. Schedule deferred maintenance. Go to "Performing the checkout procedure" on page 149.
652-772	2D2 292	A non-critical error has been detected: intermediate or system bus time-out error. Schedule deferred maintenance. Go to "Performing the checkout procedure" on page 149.
652-773	227	A non-critical error has been detected: intermediate or system bus data parity error. Schedule deferred maintenance. Go to "Performing the checkout procedure" on page 149.
652-88x		The CEC or SPCN reported a non-critical error. <ol style="list-style-type: none"> Schedule deferred maintenance. Refer to the entry MAP in this system unit system service guide, with the 8-digit error and location codes, for the necessary repair action. If the 8-digit error and location codes were NOT reported, then run diagnostics in problem determination mode and record and report the 8-digit error and location codes for this SRN.
652-89x		The CEC or SPCN reported a non-critical error. <ol style="list-style-type: none"> Schedule deferred maintenance. Refer to the entry MAP in this system unit system service guide, with the 8-digit error and location codes, for the necessary repair action. If the 8-digit error and location codes were NOT reported, then run diagnostics in problem determination mode and record and report the 8-digit error and location codes for this SRN.
814-112	814	The NVRAM test failed. Go to "Performing the checkout procedure" on page 149.

SRN	FFC	Description and Action
814-113	221	The VPD test failed. Go to "Performing the checkout procedure" on page 149.
814-114	814	I/O Card NVRAM test failed. Go to "Performing the checkout procedure" on page 149.
815-100	815	The floating-point processor test failed. Go to "Performing the checkout procedure" on page 149.
815-101	815	Floating point processor failed. Go to "Performing the checkout procedure" on page 149.
815-102	815	Floating point processor failed. Go to "Performing the checkout procedure" on page 149.
815-200	815 7C0	Power-on self-test indicates a processor failure. Go to "Performing the checkout procedure" on page 149.
815-201	815	Processor has a status of failed. Processors with a failed status are deconfigured and therefore cannot be tested or used by the system. Go to "Performing the checkout procedure" on page 149.
817-123	817	The I/O planar time-of-day clock test failed. Go to "Performing the checkout procedure" on page 149.
817-124	817	Time of day RAM test failed. Go to "Performing the checkout procedure" on page 149.
817-210	817	The time-of-day clock is at POR. Go to "Performing the checkout procedure" on page 149.
817-211	817	Time of day POR test failed. Go to "Performing the checkout procedure" on page 149.
817-212	151	The battery is low. Go to "Performing the checkout procedure" on page 149.
817-213	817	The real-time clock is not running. Go to "Performing the checkout procedure" on page 149.
817-215	817	Time of day clock not running test failed. Go to "Performing the checkout procedure" on page 149.
817-217	817	Time of day clock not running. Go to "Performing the checkout procedure" on page 149.
887-101	887	POS register test failed. Go to "Performing the checkout procedure" on page 149.
887-102		887I/O register test failed. Go to "Performing the checkout procedure" on page 149.
887-103	887	Local RAM test failed. Go to "Performing the checkout procedure" on page 149.
887-104	887	Vital Product Data (VPD) failed. Go to "Performing the checkout procedure" on page 149.
887-105	887	LAN coprocessor internal tests failed. Go to "Performing the checkout procedure" on page 149.
887-106	887	Internal loopback test failed. Go to "Performing the checkout procedure" on page 149.
887-107	887	External loopback test failed. Go to "Performing the checkout procedure" on page 149.
887-108	887	External loopback test failed. Go to "Performing the checkout procedure" on page 149.
887-109	887	External loopback parity tests failed. Go to "Performing the checkout procedure" on page 149.
887-110	887	External loopback fairness test failed. Go to "Performing the checkout procedure" on page 149.
887-111	887	External loopback fairness and parity tests failed. Go to "Performing the checkout procedure" on page 149.
887-112	887	External loopback (twisted pair) test failed. Go to "Performing the checkout procedure" on page 149.
887-113	887	External loopback (twisted pair) parity test failed. Go to "Performing the checkout procedure" on page 149.
887-114	887	Ethernet loopback (twisted pair) fairness test failed. Go to "Performing the checkout procedure" on page 149.
887-115	887	External loopback (twisted pair) fairness and parity tests failed. Go to "Performing the checkout procedure" on page 149.
887-116	887	Twisted pair wrap data failed. Go to "Performing the checkout procedure" on page 149.
887-117	887	Software device configuration fails. Go to "Performing the checkout procedure" on page 149.
887-118	887	Device driver indicates a hardware problem. Go to "Performing the checkout procedure" on page 149.
887-120	887	Device driver indicates a hardware problem. Go to "Performing the checkout procedure" on page 149.

SRN	FFC	Description and Action
887-121	B08	Ethernet transceiver test failed. Go to "Performing the checkout procedure" on page 149.
887-122	B09	Ethernet 10 base-2 transceiver test failed. Go to "Performing the checkout procedure" on page 149.
887-123	887	Internal loopback test failed. Go to "Performing the checkout procedure" on page 149.
887-124	887	Software error log indicates a hardware problem. Go to "Performing the checkout procedure" on page 149.
887-125	887	Fuse test failed. Go to "Performing the checkout procedure" on page 149.
887-202	887	Vital Product Data test failed. Go to "Performing the checkout procedure" on page 149.
887-203	887	Vital Product Data test failed. Go to "Performing the checkout procedure" on page 149.
887-209	887	RJ-45 converter test failed. Go to "Performing the checkout procedure" on page 149.
887-304	887	Coprocessor internal test failed. Go to "Performing the checkout procedure" on page 149.
887-305	887	Internal loopback test failed. Go to "Performing the checkout procedure" on page 149.
887-306	887	Internal loopback test failed. Go to "Performing the checkout procedure" on page 149.
887-307	887	External loopback test failed. Go to "Performing the checkout procedure" on page 149.
887-319	887	Software device driver indicates a hardware failure. Go to "Performing the checkout procedure" on page 149.
887-400	887	Fuse test failed. Go to "Performing the checkout procedure" on page 149.
887-401	887	Circuit breaker for Ethernet test failed. Go to "Performing the checkout procedure" on page 149.
887-402	887	Ethernet 10 Base-2 transceiver test failed. Go to "Performing the checkout procedure" on page 149.
887-403	887	Ethernet 10 Base-T transceiver test failed. Go to "Performing the checkout procedure" on page 149.
887-405	887	Ethernet- network Rerun diagnostics in advanced mode for accurate problem determination. Go to "Performing the checkout procedure" on page 149.
950-2506	2506 221	Missing options resolution for 3Gb SAS Adapter card. Try each of the following steps. After reseating, removing, or replacing a part, retry the operation. 1. Check the management-module event log. If an error was recorded by the system, see "POST progress codes (checkpoints)" on page 71. 2. Replace any parts reported by the diagnostic program. 3. Reseat the 3Gb SAS Adapter card. 4. Replace the 3Gb SAS Adapter card. 3. Replace the system-board and chassis assembly
2506-102E	722	Out of alternate disk storage for storage. Go to "Performing the checkout procedure" on page 149.
2506-3002	722	Addressed device failed to respond to selection. Go to "Performing the checkout procedure" on page 149.
2506-3010	722	Disk returned wrong response to adapter. Go to "Performing the checkout procedure" on page 149.
2506-3020	-	Storage subsystem configuration error. Go to "Performing the checkout procedure" on page 149.
2506-3100	-	Controller detected device bus interface error. Go to "Performing the checkout procedure" on page 149.
2506-3109	-	Controller timed out a device command. Go to "Performing the checkout procedure" on page 149.
2506-3110	-	Device bus interface error. Go to "Performing the checkout procedure" on page 149.
2506-4010	-	Configuration error, incorrect connection between cascaded enclosures. Go to "Performing the checkout procedure" on page 149.
2506-4020	-	Configuration error, connections exceed IOA design limits. Go to "Performing the checkout procedure" on page 149.

SRN	FFC	Description and Action
2506-4030	-	Configuration error, incorrect multipath connection. Go to "Performing the checkout procedure" on page 149.
2506-4040	-	Configuration error, incomplete multipath connection between controller and enclosure detected. Go to "Performing the checkout procedure" on page 149.
2506-4041	-	Configuration error, incomplete multipath connection between enclosure and device detected. Go to "Performing the checkout procedure" on page 149.
2506-4050	-	Attached enclosure does not support required multipath function. Go to "Performing the checkout procedure" on page 149.
2506-4060	-	Multipath redundancy level got worse. Go to "Performing the checkout procedure" on page 149.
2506-4100	-	Device bus fabric error. Go to "Performing the checkout procedure" on page 149.
2506-4101	-	Temporary device bus fabric error. Go to "Performing the checkout procedure" on page 149.
2506-4110	-	Unsupported enclosure function detected. Go to "Performing the checkout procedure" on page 149.
2506-4150	2506	PCI bus error detected by controller. Go to "Performing the checkout procedure" on page 149.
2506-4160	2506	PCI bus error detected by controller. Go to "Performing the checkout procedure" on page 149.
2506-7001	722	Temporary disk data error. Go to "Performing the checkout procedure" on page 149.
2506-8008	BAT	A permanent Cache Battery Pack failure occurred. Go to "Performing the checkout procedure" on page 149.
2506-8009	BAT	Impending Cache Battery Pack failure. Go to "Performing the checkout procedure" on page 149.
2506-8150	2506	Controller failure. Go to "Performing the checkout procedure" on page 149.
2506-8157	2506	Temporary controller failure. Go to "Performing the checkout procedure" on page 149.
2506-9000	-	Controller detected device error during configuration discovery. Go to "Performing the checkout procedure" on page 149.
2506-9001	-	Controller detected device error during configuration discovery. Go to "Performing the checkout procedure" on page 149.
2506-9002	-	Controller detected device error during configuration discovery. Go to "Performing the checkout procedure" on page 149.
2506-9008	-	Controller does not support function expected for one or more disks. Go to "Performing the checkout procedure" on page 149.
2506-9010	-	Cache data associated with attached disks cannot be found. Go to "Performing the checkout procedure" on page 149.
2506-9011	-	Cache data belongs to disks other than those attached. Go to "Performing the checkout procedure" on page 149.
2506-9020	-	Two or more disks are missing from a RAID-5 or RAID 6 Disk Array. Go to "Performing the checkout procedure" on page 149.
2506-9021	-	Two or more disks are missing from a RAID-5 or RAID 6 Disk Array. Go to "Performing the checkout procedure" on page 149.
2506-9022	-	Two or more disks are missing from a RAID-5 or RAID 6 Disk Array. Go to "Performing the checkout procedure" on page 149.
2506-9023	-	One or more Disk Array members are not at required physical locations. Go to "Performing the checkout procedure" on page 149.
2506-9024	-	Physical location of Disk Array members conflict with another Disk Array. Go to "Performing the checkout procedure" on page 149.
2506-9025	-	Incompatible disk installed at degraded disk location in Disk Array. Go to "Performing the checkout procedure" on page 149.
2506-9026	-	Previously degraded disk in Disk Array not found at required physical location. Go to "Performing the checkout procedure" on page 149.
2506-9027	-	Disk Array is or would become degraded and parity data is out of synchronization. Go to "Performing the checkout procedure" on page 149.

SRN	FFC	Description and Action
2506-9028	-	Maximum number of functional Disk Arrays has been exceeded. Go to "Performing the checkout procedure" on page 149.
2506-9029	-	Maximum number of functional Disk Arrays disks has been exceeded. Go to "Performing the checkout procedure" on page 149.
2506-9030	-	Disk Array is degraded due to missing/failed disk. Go to "Performing the checkout procedure" on page 149.
2506-9031	-	Automatic reconstruction initiated for Disk Array. Go to "Performing the checkout procedure" on page 149.
2506-9032	-	Disk Array is degraded due to missing/failed disk. Go to "Performing the checkout procedure" on page 149.
2506-9041	-	Background Disk Array parity checking detected and corrected errors. Go to "Performing the checkout procedure" on page 149.
2506-9042	-	Background Disk Array parity checking detected and corrected errors on specified disk. Go to "Performing the checkout procedure" on page 149.
2506-9050	-	Required cache data can not be located for one or more disks. Go to "Performing the checkout procedure" on page 149.
2506-9051	-	Cache data exists for one or more missing/failed disks. Go to "Performing the checkout procedure" on page 149.
2506-9052	-	Cache data exists for one or more modified disks. Go to "Performing the checkout procedure" on page 149.
2506-9054	-	RAID controller resources not available due to previous problems. Go to "Performing the checkout procedure" on page 149.
2506-9060	-	One or more disk pairs are missing from a RAID-10 Disk Array. Go to "Performing the checkout procedure" on page 149.
2506-9061	-	One or more disks are missing from a RAID-0 Disk Array. Go to "Performing the checkout procedure" on page 149.
2506-9062	-	One or more disks are missing from a RAID-0 Disk Array. Go to "Performing the checkout procedure" on page 149.
2506-9063	-	Maximum number of functional Disk Arrays has been exceeded. Go to "Performing the checkout procedure" on page 149.
2506-9073	-	Multiple controllers connected in an invalid configuration. Go to "Performing the checkout procedure" on page 149.
2506-9074	-	Multiple controllers not capable of similar functions or controlling same set of devices. Go to "Performing the checkout procedure" on page 149.
2506-9075	-	Incomplete multipath connection between controller and remote controller. Go to "Performing the checkout procedure" on page 149.
2506-9076	-	Missing remote controller. Go to "Performing the checkout procedure" on page 149.
2506-9081	-	Controller detected device error during internal media recovery. Go to "Performing the checkout procedure" on page 149.
2506-9082	-	Controller detected device error during internal media recovery. Go to "Performing the checkout procedure" on page 149.
2506-9090	-	Disk has been modified after last known status. Go to "Performing the checkout procedure" on page 149.
2506-9091	-	Incorrect disk configuration change has been detected. Go to "Performing the checkout procedure" on page 149.
2506-9092	-	Disk requires Format before use. Format the disk and retry the operation.
2506-FF3D	2506	Temporary controller failure. Retry the operation.
2506-FFF3	-	Disk media format bad. Reformat the disk and retry the operation.
2506-FFF4	722	Device problem. Perform diagnostics on the device and retry the operation.
2506-FFF6	722	Device detected recoverable error. Retry the operation.
2506-FFFA	722	Temporary device bus error. Retry the operation.
2506-FFFE	-	Temporary device bus error. Retry the operation.

SRN	FFC	Description and Action
252B-101	252B	Adapter configuration error. 1. Check the management-module event log. If an error was recorded by the system, see "POST progress codes (checkpoints)" on page 71. 2. Replace any parts reported by the diagnostic program. 3. Replace the system-board and chassis assembly.
252B-710	252B	Permanent adapter failure. 1. Check the management-module event log. If an error was recorded by the system, see "POST progress codes (checkpoints)" on page 71. 2. Replace any parts reported by the diagnostic program. 3. Replace the system-board and chassis assembly.
252B-711	252B	Adapter failure. 1. Check the management-module event log. If an error was recorded by the system, see "POST progress codes (checkpoints)" on page 71. 2. Replace any parts reported by the diagnostic program. 3. Replace the system-board and chassis assembly.
252B-712	252B	Adapter failure. 1. Check the management-module event log. If an error was recorded by the system, see "POST progress codes (checkpoints)" on page 71. 2. Replace any parts reported by the diagnostic program. 3. Replace the system-board and chassis assembly.
252B-713	252B	Adapter failure. 1. Check the management-module event log. If an error was recorded by the system, see "POST progress codes (checkpoints)" on page 71. 2. Replace any parts reported by the diagnostic program. 3. Replace the system-board and chassis assembly.
252B-714	252B	Temporary adapter failure. 1. Check the management-module event log. If an error was recorded by the system, see "POST progress codes (checkpoints)" on page 71. 2. Replace any parts reported by the diagnostic program. 3. Replace the system-board and chassis assembly.
252B-715	252B	Temporary adapter failure. 1. Check the management-module event log. If an error was recorded by the system, see "POST progress codes (checkpoints)" on page 71. 2. Replace any parts reported by the diagnostic program. 3. Replace the system-board and chassis assembly.
252B-716	252B 293	PCI bus error detected by EEH. 1. Check the management-module event log. If an error was recorded by the system, see "POST progress codes (checkpoints)" on page 71. 2. Replace any parts reported by the diagnostic program. 3. Replace the system-board and chassis assembly.
252B-717	252B 293	PCI bus error detected by adapter. 1. Check the management-module event log. If an error was recorded by the system, see "POST progress codes (checkpoints)" on page 71. 2. Replace any parts reported by the diagnostic program. 3. Replace the system-board and chassis assembly.
252B-718	252B 293	Temporary PCI bus error detected by adapter. 1. Check the management-module event log. If an error was recorded by the system, see "POST progress codes (checkpoints)" on page 71. 2. Replace any parts reported by the diagnostic program. 3. Replace the system-board and chassis assembly.

SRN	FFC	Description and Action
252B-719	252B	Device bus termination power lost or not detected. 1. Check the management-module event log. If an error was recorded by the system, see "POST progress codes (checkpoints)" on page 71. 2. Replace any parts reported by the diagnostic program. 3. Replace the system-board and chassis assembly.
252B-720	252B	Adapter detected device bus failure. 1. Check the management-module event log. If an error was recorded by the system, see "POST progress codes (checkpoints)" on page 71. 2. Replace any parts reported by the diagnostic program. 3. Replace the system-board and chassis assembly.
252B-721	252B	Temporary adapter detected device bus failure. 1. Check the management-module event log. If an error was recorded by the system, see "POST progress codes (checkpoints)" on page 71. 2. Replace any parts reported by the diagnostic program. 3. Replace the system-board and chassis assembly.
252B-722	252B	Device bus interface problem. 1. Check the management-module event log. If an error was recorded by the system, see "POST progress codes (checkpoints)" on page 71. 2. Replace any parts reported by the diagnostic program. 3. Replace the system-board and chassis assembly.
252B-723	252B	Device bus interface problem. 1. Check the management-module event log. If an error was recorded by the system, see "POST progress codes (checkpoints)" on page 71. 2. Replace any parts reported by the diagnostic program. 3. Replace the system-board and chassis assembly.
254E-201	254E 221	Adapter configuration error. Go to "Performing the checkout procedure" on page 149.
254E-601	254	Error log analysis indicates adapter failure. Go to "Performing the checkout procedure" on page 149.
254E-602	254	Error log analysis indicates an error attention condition. Go to "Performing the checkout procedure" on page 149.
254E-603	254	Error log analysis indicates that the microcode could not be loaded on the adapter. Go to "Performing the checkout procedure" on page 149.
254E-604	254	Error log analysis indicates a permanent adapter failure. Go to "Performing the checkout procedure" on page 149.
254E-605	254	Error log analysis indicates permanent adapter failure is reported on the other port of this adapter. Go to "Performing the checkout procedure" on page 149.
254E-606	254	Error log analysis indicates adapter failure. Go to "Performing the checkout procedure" on page 149.
254E-701	254E 221	Error log analysis indicates permanent adapter failure. Go to "Performing the checkout procedure" on page 149.
254E-702	254E 221	Error log analysis indicates permanent adapter failure is reported on the other port of this adapter. Go to "Performing the checkout procedure" on page 149.
2567-xxx	2567	USB integrated system-board and chassis assembly. Go to "Performing the checkout procedure" on page 149.
256D-201	256D 221	Adapter configuration error. 1. Check the management-module event log. If an error was recorded by the system, see "POST progress codes (checkpoints)" on page 71. 2. Replace any parts reported by the diagnostic program. 3. Replace the system-board and chassis assembly.

SRN	FFC	Description and Action
256D-601	256D	Error log analysis indicates adapter. 1. Check the management-module event log. If an error was recorded by the system, see "POST progress codes (checkpoints)" on page 71. 2. Replace any parts reported by the diagnostic program. 3. Replace the system-board and chassis assembly.
256D-602	256D	Error log analysis indicates an error attention condition. 1. Check the management-module event log. If an error was recorded by the system, see "POST progress codes (checkpoints)" on page 71. 2. Replace any parts reported by the diagnostic program. 3. Replace the system-board and chassis assembly.
256D-603	256D	Error Log Analysis indicates that the microcode could not be loaded on the adapter. 1. Check the management-module event log. If an error was recorded by the system, see "POST progress codes (checkpoints)" on page 71. 2. Replace any parts reported by the diagnostic program. 3. Replace the system-board and chassis assembly.
256D-604	256D 210	Error Log Analysis indicates a permanent adapter failure. 1. Check the management-module event log. If an error was recorded by the system, see "POST progress codes (checkpoints)" on page 71. 2. Replace any parts reported by the diagnostic program. 3. Replace the system-board and chassis assembly.
256D-605	256D	Error Log Analysis indicates a permanent adapter failure. 1. Check the management-module event log. If an error was recorded by the system, see "POST progress codes (checkpoints)" on page 71. 2. Replace any parts reported by the diagnostic program. 3. Replace the system-board and chassis assembly.
256D-606	256D	Error Log Analysis indicates adapter failure. 1. Check the management-module event log. If an error was recorded by the system, see "POST progress codes (checkpoints)" on page 71. 2. Replace any parts reported by the diagnostic program. 3. Replace the system-board and chassis assembly.
256D-701	256D 221	Error Log Analysis indicates permanent adapter failure. 1. Check the management-module event log. If an error was recorded by the system, see "POST progress codes (checkpoints)" on page 71. 2. Replace any parts reported by the diagnostic program. 3. Replace the system-board and chassis assembly.
256D-702	256D 221	Error Log Analysis indicates permanent adapter failure is reported on the other port of this adapter. 1. Check the management-module event log. If an error was recorded by the system, see "POST progress codes (checkpoints)" on page 71. 2. Replace any parts reported by the diagnostic program. 3. Replace the system-board and chassis assembly.
25C4-xxx	25C4	Generic reference for Broadcom adapter. Go to "Performing the checkout procedure" on page 149.
25C4-201	25C4	Configuration error. Go to "Performing the checkout procedure" on page 149.
25C4-701	25C4	Permanent adapter failure. Go to "Performing the checkout procedure" on page 149.
25C4-601	25C4	Download firmware error. Go to "Performing the checkout procedure" on page 149.
25C4-602	25C4	EEPROM read error. Go to "Performing the checkout procedure" on page 149.
2604-xxx	2604	Generic reference for 4Gb Fibre Channel Adapter card. Go to "Performing the checkout procedure" on page 149.
2604-102	2604	Reset Test failure for the Fibre Channel adapter card. Replace the 4Gb Fibre Channel Adapter card.

SRN	FFC	Description and Action
2604-103	2604	Register Test failure for the Fibre Channel adapter card. Replace the 4Gb Fibre Channel Adapter card.
2604-104	2604	SRAM Test failure for the Fibre Channel adapter card. Replace the 4Gb Fibre Channel Adapter card.
2604-105	2604	Internal Wrap Test failure for the Fibre Channel adapter card. Replace the 4Gb Fibre Channel Adapter card.
2604-106	2604	Gigabit Link Module (GLM) Wrap Test failure for the Fibre Channel adapter card. Replace the 4Gb Fibre Channel Adapter card.
2604-108	2604 221	Enhanced Error Handling Failure on the bus for the Fibre Channel adapter card. Go to <i>"Performing the checkout procedure"</i> on page 149.
2604-110	2604	Enhanced Error Handling Failure on the Fibre Channel adapter card. Replace the 4Gb Fibre Channel Adapter card.
2604-201	2604 221	Configuration Register Test Failure for the Fibre Channel adapter card. Go to <i>"Performing the checkout procedure"</i> on page 149.
2604-203	2604	PCI Wrap Test Failure for the Fibre Channel adapter card. Replace the 4Gb Fibre Channel Adapter card.
2604-204	2604 221	DMA Test Failure for the Fibre Channel adapter card. Go to <i>"Performing the checkout procedure"</i> on page 149.
2604-205	2604 221	Error on Read/Write Operation for the Fibre Channel adapter card. Go to <i>"Performing the checkout procedure"</i> on page 149.
2604-701	2604	Error Log Analysis indicates that the adapter self-test failed for the Fibre Channel adapter card. Go to <i>"Performing the checkout procedure"</i> on page 149.
2604-703	2604	Error Log Analysis indicates that an unknown adapter error has occurred for the Fibre Channel adapter card. Go to <i>"Performing the checkout procedure"</i> on page 149.
2604-704	2604	Error Log Analysis indicates that an adapter error has occurred for the Fibre Channel adapter card. Go to <i>"Performing the checkout procedure"</i> on page 149.
2604-705	2604	Error Log Analysis indicates that a parity error has been detected for the Fibre Channel adapter card. The adapter must be replaced immediately. Failure to do so could result in data being read or written incorrectly.
2604-706	2604	Error Log Analysis indicates that a fatal hardware error has occurred for the Fibre Channel adapter card. This adapter was successfully taken off-line. It will remain off-line until reconfigured or the system is rebooted. This adapter must be replaced and not brought back on-line. Failure to adhere to this action could result in data being read or written incorrectly or in the loss of data.
2607-xxx	2607	Generic reference for 8Gb PCIe Fibre Channel Expansion Card. o to <i>"Performing the checkout procedure"</i> on page 149.
2607-102	2607	Reset Test failure for the Fibre Channel adapter card. Replace the 8Gb PCIe Fibre hannel Expansion Card.
2607-103	2607	Register Test failure for the Fibre Channel adapter card. Replace the 8Gb PCIe Fibre hannel Expansion Card.
2607-104	2607	SRAM Test failure for the Fibre Channel adapter card. Replace the 8Gb PCIe Fibre hannel Expansion Card.
2607-105	2607	Internal Wrap Test failure for the Fibre Channel adapter card. Replace the 8Gb PCIe ibre Channel Expansion Card.
2607-106	2607	Gigabit Link Module (GLM) Wrap Test failure for the Fibre Channel adapter card. Replace the 8Gb PCIe Fibre Channel Expansion Card.
2607-108	2607 221	Enhanced Error Handling Failure on the bus for the Fibre Channel adapter card. Go to <i>"Performing the checkout procedure"</i> on page 149.
2607-110	2607	Enhanced Error Handling Failure on the Fibre Channel adapter card. Replace the 8Gb PCIe Fibre Channel Expansion Card.
2607-201	2607 221	Configuration Register Test Failure for the Fibre Channel adapter card. Go to <i>"Performing the checkout procedure"</i> on page 149.

SRN	FFC	Description and Action
2607-203	2607	PCI Wrap Test Failure for the Fibre Channel adapter card. Replace the 8Gb PCIe Fibre Channel Expansion Card.
2607-204	2607 221	DMA Test Failure for the Fibre Channel adapter card. Go to <i>"Performing the checkout procedure"</i> on page 149.
2607-205	2607 221	Error on Read/Write Operation for the Fibre Channel adapter card. Go to <i>"Performing the checkout procedure"</i> on page 149.
2607-701	2607	Error Log Analysis indicates that the adapter self-test failed for the Fibre Channel adapter card. Go to <i>"Performing the checkout procedure"</i> on page 149.
2607-703	2607	Error Log Analysis indicates that an unknown adapter error has occurred for the Fibre Channel adapter card. Go to <i>"Performing the checkout procedure"</i> on page 149.
2607-704	2607	Error Log Analysis indicates that an adapter error has occurred for the Fibre Channel adapter card. Go to <i>"Performing the checkout procedure"</i> on page 149.
2607-705	2607	Error Log Analysis indicates that a parity error has been detected for the Fibre Channel adapter card. The adapter must be replaced immediately. Failure to do so could result in data being read or written incorrectly.
2607-706	2607	Error Log Analysis indicates that a fatal hardware error has occurred for the Fibre Channel adapter card. This adapter was successfully taken off-line. It will remain off-line until reconfigured or the system is rebooted. This adapter must be replaced and not brought back on-line. Failure to adhere to this action could result in data being read or written incorrectly or in the loss of data.
2624-xxx	2624	Generic reference for 4X PCI-E DDR InfiniBand Host Channel Adapter - system-board and chassis assembly. Go to <i>"Performing the checkout procedure"</i> on page 149.
2624-101	2624	Configuration failure - system-board and chassis assembly. Go to <i>"Performing the checkout procedure"</i> on page 149.
2624-102	2624	Queue pair create failure - system-board and chassis assembly. Go to <i>"Performing the checkout procedure"</i> on page 149.
2624-103	2624	Loop back test failure - system-board and chassis assembly. Go to <i>"Performing the checkout procedure"</i> on page 149.
2624-201	Cable network	Loop back test failure. Do the following steps one at a time, in order, and rerun the test after each step: 1. Reseat the cable. 2. Replace the cable. 3. Verify that the network is functional. 3. Verify that the network switch is functional.
2624-301	Cable network 2624	Loop back test failure. Do the following steps one at a time, in order, and rerun the test after each step: 1. Reseat the cable. 2. Replace the cable. 3. Verify that the network is functional. 3. Verify that the network switch is functional. 4. Go to <i>"Performing the checkout procedure"</i> on page 149.
2624-701	2624	Error Log Analysis indicates that this adapter has failed due to an internal error - system-board and chassis assembly. Go to <i>"Performing the checkout procedure"</i> on page 149.
2624-702	2624	Error Log Analysis indicates that this adapter has failed due to a failure with the uplink interface used to connect this device to the host processor - system-board and chassis assembly. Go to <i>"Performing the checkout procedure"</i> on page 149.
2624-703	2624	Error Log Analysis indicates that this adapter has failed due to a memory error - system-board and chassis assembly. Go to <i>"Performing the checkout procedure"</i> on page 149.
2624-704	2624	Error Log Analysis indicates that this adapter has failed due to an unrecoverable internal parity error - system-board and chassis assembly. Go to <i>"Performing the checkout procedure"</i> on page 149.

SRN	FFC	Description and Action
2624-705	2624	Error Log Analysis indicates that this adapter has failed due to a internal error - system-board and chassis assembly. Go to "Performing the checkout procedure" on page 149.
2624-706	2624	Error Log Analysis indicates that this adapter has failed due to a memory error - system-board and chassis assembly. Go to "Performing the checkout procedure" on page 149.
2640-121	2640	Physical volume hardware error. Go to "Performing the checkout procedure" on page 149.
2640-131	2640	Smart status threshold exceeded. Go to "Performing the checkout procedure" on page 149.
2640-132	2640	Command timeouts threshold exceeded. Go to "Performing the checkout procedure" on page 149.
2640-133	2640	Command timeout with error condition. Go to "Performing the checkout procedure" on page 149.
2640-134	2640	Hardware command or DMA failure. Go to "Performing the checkout procedure" on page 149.
2640-135	2640	IDE DMA error with no error status. Go to "Performing the checkout procedure" on page 149.
2640-136	2640 2631	Timeout waiting for controller or drive with no busy status. Go to "Performing the checkout procedure" on page 149.
2D02-xxx	2631	Generic reference for USB controller/adapter - system-board and chassis assembly. Go to "Performing the checkout procedure" on page 149.
FFC-724	FFC	Temporary device bus interface problem. 1. Check the management-module event log. If an error was recorded by the system, see "POST progress codes (checkpoints)" on page 71. 2. Replace any parts reported by the diagnostic program. 3. Go to "Performing the checkout procedure" on page 149.
FFC-725	FFC	Temporary device bus interface problem. 1. Check the management-module event log. If an error was recorded by the system, see "POST progress codes (checkpoints)" on page 71. 2. Replace any parts reported by the diagnostic program. 3. Go to "Performing the checkout procedure" on page 149.

2.4.3.3 A00-FF0 through A24-xxx SRNs

AIX might generate service request numbers (SRNs) from A00-FF0 to A24-xxx.

Note Some SRNs in this sequence might have 4 rather than 3 digits after the dash (-).

Table 2-23 shows the meaning of an x in any of the following SRNs, such as A01-00x.

Table 2-23. Meaning of the last character (x) after the hyphen

Number	Meaning
1	Replace all FRUs listed
2	Hot swap supported
4	Software might be the cause
8	Reserved

Table 2-24. A00-FF0 through A24-xxx SRNs

SRN	Description	FRU/action
A00-FF0	Error log analysis is unable to determine the error. The error log indicates the following physical FRU locations as the probable causes.	<ol style="list-style-type: none"> 1. Check the management-module event log; if an error was recorded by the system, see "POST progress codes (checkpoints)" on page 71. 2. If no entry is found, replace the system-board and chassis assembly.
A01-00x	Error log analysis indicates an error detected by the microprocessor, but the failure could not be isolated.	<ol style="list-style-type: none"> 1. Check the management-module event log; if an error was recorded by the system, see "POST progress codes (checkpoints)" on page 71. 2. If no entry is found, replace the system-board and chassis assembly.
A01-01x	GCPU internal error.	<ol style="list-style-type: none"> 1. Check the management-module event log; if an error was recorded by the system, see "POST progress codes (checkpoints)" on page 71. 2. If no entry is found, replace the system-board and chassis assembly.
A01-02x	CPU internal cache or cache controller error.	<ol style="list-style-type: none"> 1. Check the management-module event log; if an error was recorded by the system, see "POST progress codes (checkpoints)" on page 71. 2. If no entry is found, replace the system-board and chassis assembly.
A01-05x	System bus time-out error.	<ol style="list-style-type: none"> 1. Check the management-module event log; if an error was recorded by the system, see "POST progress codes (checkpoints)" on page 71. 2. If no entry is found, replace the system-board and chassis assembly.
A01-06x	Time-out error waiting for I/O.	<ol style="list-style-type: none"> 1. Check the management-module event log; if an error was recorded by the system, see "POST progress codes (checkpoints)" on page 71. 2. If no entry is found, replace the system-board and chassis assembly.

SRN	Description	FRU/action
A01-07x	System bus parity error.	<ol style="list-style-type: none"> 1. Check the management-module event log; if an error was recorded by the system, see "POST progress codes (checkpoints)" on page 71. 2. If no entry is found, replace the system-board and chassis assembly.
A01-08x	System bus protocol/transfer error.	<ol style="list-style-type: none"> 1. Check the management-module event log; if an error was recorded by the system, see "POST progress codes (checkpoints)" on page 71. 2. If no entry is found, replace the system-board and chassis assembly.
A02-00x	Error log analysis indicates an error detected by the memory controller, but the failure could not be isolated.	<ol style="list-style-type: none"> 1. Check the management-module event log; if an error was recorded by the system, see "POST progress codes (checkpoints)" on page 71. 2. If no entry is found, replace the system-board and chassis assembly.
A02-01x	Uncorrectable Memory Error.	<ol style="list-style-type: none"> 1. Check the management-module event log; if an error was recorded by the system, see "POST progress codes (checkpoints)" on page 71. 2. If no entry is found, replace the system-board and chassis assembly.
A02-03x	Correctable error threshold exceeded.	<ol style="list-style-type: none"> 1. Check the management-module event log; if an error was recorded by the system, see "POST progress codes (checkpoints)" on page 71. 2. If no entry is found, replace the system-board and chassis assembly.
A02-04x	Memory Control subsystem internal error.	<ol style="list-style-type: none"> 1. Check the management-module event log; if an error was recorded by the system, see "POST progress codes (checkpoints)" on page 71. 2. If no entry is found, replace the system-board and chassis assembly.
A02-05x	Memory Address Error (invalid address or access attempt).	<ol style="list-style-type: none"> 1. Check the management-module event log; if an error was recorded by the system, see "POST progress codes (checkpoints)" on page 71. 2. If no entry is found, replace the system-board and chassis assembly.
A02-06x	Memory Data error (Bad data going to memory).	<ol style="list-style-type: none"> 1. Check the management-module event log; if an error was recorded by the system, see "POST progress codes (checkpoints)" on page 71. 2. If no entry is found, replace the system-board and chassis assembly.
A02-09x	System bus parity error.	<ol style="list-style-type: none"> 1. Check the management-module event log; if an error was recorded by the system, see "POST progress codes (checkpoints)" on page 71. 2. If no entry is found, replace the system-board and chassis assembly.
A02-10x	System bus time-out error.	<ol style="list-style-type: none"> 1. Check the management-module event log; if an error was recorded by the system, see "POST progress codes (checkpoints)" on page 71. 2. If no entry is found, replace the system-board and chassis assembly.
A02-11x	System bus protocol/transfer error.	<ol style="list-style-type: none"> 1. Check the management-module event log; if an error was recorded by the system, see "POST progress codes (checkpoints)" on page 71. 2. If no entry is found, replace the system-board and chassis assembly.
A02-12x	I/O Host Bridge time-out error.	<ol style="list-style-type: none"> 1. Check the management-module event log; if an error was recorded by the system, see "POST progress codes (checkpoints)" on page 71. 2. If no entry is found, replace the system-board and chassis assembly.

SRN	Description	FRU/action
A02-13x	I/O Host Bridge address/data parity error.	<ol style="list-style-type: none"> 1. Check the management-module event log; if an error was recorded by the system, see "POST progress codes (checkpoints)" on page 71. 2. If no entry is found, replace the system-board and chassis assembly.
A03-00x	Error log analysis indicates an error detected by the I/O device, but the failure could not be isolated.	<ol style="list-style-type: none"> 1. Check the management-module event log; if an error was recorded by the system, see "POST progress codes (checkpoints)" on page 71. 2. If no entry is found, replace the system-board and chassis assembly.
A03-01x	I/O Bus Address parity error.	<ol style="list-style-type: none"> 1. Check the management-module event log; if an error was recorded by the system, see "POST progress codes (checkpoints)" on page 71. 2. If no entry is found, replace the system-board and chassis assembly.
A03-05x	I/O Error on non-PCI bus.	<ol style="list-style-type: none"> 1. Check the management-module event log; if an error was recorded by the system, see "POST progress codes (checkpoints)" on page 71. 2. If no entry is found, replace the system-board and chassis assembly.
A03-07x	System bus address parity error.	<ol style="list-style-type: none"> 1. Check the management-module event log; if an error was recorded by the system, see "POST progress codes (checkpoints)" on page 71. 2. If no entry is found, replace the system-board and chassis assembly.
A03-09x	System bus data parity error.	<ol style="list-style-type: none"> 1. Check the management-module event log; if an error was recorded by the system, see "POST progress codes (checkpoints)" on page 71. 2. If no entry is found, replace the system-board and chassis assembly.
A03-11x	System bus time-out error.	<ol style="list-style-type: none"> 1. Check the management-module event log; if an error was recorded by the system, see "POST progress codes (checkpoints)" on page 71. 2. If no entry is found, replace the system-board and chassis assembly.
A03-12x	Error on System bus.	<ol style="list-style-type: none"> 1. Check the management-module event log; if an error was recorded by the system, see "POST progress codes (checkpoints)" on page 71. 2. If no entry is found, replace the system-board and chassis assembly.
A03-13x	I/O Expansion bus parity error.	<ol style="list-style-type: none"> 1. Check the management-module event log; if an error was recorded by the system, see "POST progress codes (checkpoints)" on page 71. 2. If no entry is found, replace the system-board and chassis assembly.
A03-14x	I/O Expansion bus time-out error.	<ol style="list-style-type: none"> 1. Check the management-module event log; if an error was recorded by the system, see "POST progress codes (checkpoints)" on page 71. 2. If no entry is found, replace the system-board and chassis assembly.
A03-15x	I/O Expansion bus connection failure.	<ol style="list-style-type: none"> 1. Check the management-module event log; if an error was recorded by the system, see "POST progress codes (checkpoints)" on page 71. 2. If no entry is found, replace the system-board and chassis assembly.
A03-16x	I/O Expansion unit not in an operating state.	<ol style="list-style-type: none"> 1. Check the management-module event log; if an error was recorded by the system, see "POST progress codes (checkpoints)" on page 71. 2. If no entry is found, replace the system-board and chassis assembly.

SRN	Description	FRU/action
A05-00x	Error log analysis indicates an environmental and power warning, but the failure could not be isolated.	<ol style="list-style-type: none"> 1. Check the management-module event log; if an error was recorded by the system, see "POST progress codes (checkpoints)" on page 71. 2. If no entry is found, replace the system-board and chassis assembly.
A05-01x	Sensor indicates a fan has failed.	<ol style="list-style-type: none"> 1. Check the management-module event log; if an error was recorded by the system, see "POST progress codes (checkpoints)" on page 71. 2. If no entry is found, replace the system-board and chassis assembly.
A05-02x	System shutdown due to a fan failure.	<ol style="list-style-type: none"> 1. Check the management-module event log; if an error was recorded by the system, see "POST progress codes (checkpoints)" on page 71. 2. If no entry is found, replace the system-board and chassis assembly.
A05-03x	Sensor indicates a voltage outside normal range.	<ol style="list-style-type: none"> 1. Check the management-module event log; if an error was recorded by the system, see "POST progress codes (checkpoints)" on page 71. 2. If no entry is found, replace the system-board and chassis assembly.
A05-04x	System shutdown due to voltage outside normal range.	<ol style="list-style-type: none"> 1. Check the management-module event log; if an error was recorded by the system, see "POST progress codes (checkpoints)" on page 71. 2. If no entry is found, replace the system-board and chassis assembly.
A05-05x	Sensor indicates an abnormally high internal temperature.	<ol style="list-style-type: none"> 1. Make sure that: <ol style="list-style-type: none"> a. The room ambient temperature is within the system operating environment. b. There is unrestricted air flow around the system. c. All system covers are closed. d. There are no fan failures 2. Check the management-module event log; if an error was recorded by the system, see "POST progress codes (checkpoints)" on page 71. 3. If no entry is found, replace the system-board and chassis assembly.
A05-06x	System shutdown due to abnormally high internal temperature.	<ol style="list-style-type: none"> 1. Make sure that: <ol style="list-style-type: none"> a. The room ambient temperature is within the system operating environment. b. There is unrestricted air flow around the system. c. All system covers are closed. d. There are no fan failures 2. Check the management-module event log; if an error was recorded by the system, see "POST progress codes (checkpoints)" on page 71. 3. If no entry is found, replace the system-board and chassis assembly.
A05-07x	Sensor indicates a power supply has failed.	<ol style="list-style-type: none"> 1. Check the management-module event log; if an error was recorded by the system, see "POST progress codes (checkpoints)" on page 71. 2. If no entry is found, replace the system-board and chassis assembly.
A05-08x	System shutdown due to power supply failure.	<ol style="list-style-type: none"> 1. Check the management-module event log; if an error was recorded by the system, see "POST progress codes (checkpoints)" on page 71. 2. If no entry is found, replace the system-board and chassis assembly.
A05-10x	System shutdown due to FRU that has failed.	<ol style="list-style-type: none"> 1. Check the management-module event log; if an error was recorded by the system, see "POST progress codes (checkpoints)" on page 71. 2. If no entry is found, replace the system-board and chassis assembly.

SRN	Description	FRU/action
A05-14x	System shutdown due to power fault with an unspecified cause.	<ol style="list-style-type: none"> 1. Check the management-module event log; if an error was recorded by the system, see "POST progress codes (checkpoints)" on page 71. 2. If no entry is found, replace the system-board and chassis assembly.
A05-19x	System shutdown due to Fan failure.	<ol style="list-style-type: none"> 1. Check the management-module event log; if an error was recorded by the system, see "POST progress codes (checkpoints)" on page 71. 2. If no entry is found, replace the system-board and chassis assembly.
A05-21x	System shutdown due to Over temperature condition.	<ol style="list-style-type: none"> 1. Make sure that: <ol style="list-style-type: none"> a. The room ambient temperature is within the system operating environment. b. There is unrestricted air flow around the system. c. All system covers are closed. d. There are no fan failures 2. Check the management-module event log; if an error was recorded by the system, see "POST progress codes (checkpoints)" on page 71. 3. If no entry is found, replace the system-board and chassis assembly.
A05-22x	System shutdown due to over temperature and fan failure.	<ol style="list-style-type: none"> 1. Check the management-module event log; if an error was recorded by the system, see "POST progress codes (checkpoints)" on page 71. 2. If no entry is found, replace the system-board and chassis assembly.
A05-24x	Power Fault specifically due to internal battery failure.	<ol style="list-style-type: none"> 1. Check the management-module event log; if an error was recorded by the system, see "POST progress codes (checkpoints)" on page 71. 2. If no entry is found, replace the system-board and chassis assembly.
A0D-00x	Error log analysis indicates an error detected by the Service Processor, but the failure could not be isolated.	<ol style="list-style-type: none"> 1. Check the management-module event log; if an error was recorded by the system, see "POST progress codes (checkpoints)" on page 71. 2. If no entry is found, replace the system-board and chassis assembly.
A0D-06x	Service Processor reports unknown communication error.	<ol style="list-style-type: none"> 1. Check the management-module event log; if an error was recorded by the system, see "POST progress codes (checkpoints)" on page 71. 2. If no entry is found, replace the system-board and chassis assembly.
A0D-07x	Internal service processor firmware error or incorrect version.	<ol style="list-style-type: none"> 1. Check the management-module event log; if an error was recorded by the system, see "POST progress codes (checkpoints)" on page 71. 2. If no entry is found, replace the system-board and chassis assembly.
A0D-08x	Other internal Service Processor hardware error.	<ol style="list-style-type: none"> 1. Check the management-module event log; if an error was recorded by the system, see "POST progress codes (checkpoints)" on page 71. 2. If no entry is found, replace the system-board and chassis assembly.
A0D-09x	Service Processor error accessing Vital Product Data EEPROM.	<ol style="list-style-type: none"> 1. Check the management-module event log; if an error was recorded by the system, see "POST progress codes (checkpoints)" on page 71. 2. If no entry is found, replace the system-board and chassis assembly.
A0D-18x	Service Processor detected NVRAM error.	<ol style="list-style-type: none"> 1. Check the management-module event log; if an error was recorded by the system, see "POST progress codes (checkpoints)" on page 71. 2. If no entry is found, replace the system-board and chassis assembly.

SRN	Description	FRU/action
A0D-19x	Service Processor error accessing Real Time Clock/Time-of-Day Clock.	<ol style="list-style-type: none"> 1. Check the management-module event log; if an error was recorded by the system, see "POST progress codes (checkpoints)" on page 71. 2. If no entry is found, replace the system-board and chassis assembly.
A0D-21x	Service Processor detect error with Time-of-Day Clock backup battery.	<ol style="list-style-type: none"> 1. Check the management-module event log; if an error was recorded by the system, see "POST progress codes (checkpoints)" on page 71. 2. If no entry is found, replace the system-board and chassis assembly.
A0D-23x	Loss of heart beat from Service Processor.	<ol style="list-style-type: none"> 1. Check the management-module event log; if an error was recorded by the system, see "POST progress codes (checkpoints)" on page 71. 2. If no entry is found, replace the system-board and chassis assembly.
A0D-24x	Service Processor detected a surveillance time-out.	<ol style="list-style-type: none"> 1. Check the management-module event log; if an error was recorded by the system, see "POST progress codes (checkpoints)" on page 71. 2. If no entry is found, replace the system-board and chassis assembly.
A0D-31x	Error detected while handling an attention/interrupt from the system hardware.	<ol style="list-style-type: none"> 1. Check the management-module event log; if an error was recorded by the system, see "POST progress codes (checkpoints)" on page 71. 2. If no entry is found, replace the system-board and chassis assembly.
A0D-35x	Mainstore or Cache IPL Diagnostic Error.	<ol style="list-style-type: none"> 1. Check the management-module event log; if an error was recorded by the system, see "POST progress codes (checkpoints)" on page 71. 2. If no entry is found, replace the system-board and chassis assembly.
A0D-36x	Other IPL Diagnostic Error.	<ol style="list-style-type: none"> 1. Check the management-module event log; if an error was recorded by the system, see "POST progress codes (checkpoints)" on page 71. 2. If no entry is found, replace the system-board and chassis assembly.
A0D-37x	Clock or PLL Error.	<ol style="list-style-type: none"> 1. Check the management-module event log; if an error was recorded by the system, see "POST progress codes (checkpoints)" on page 71. 2. If no entry is found, replace the system-board and chassis assembly.
A0D-38x	Hardware Scan or Initialization Error.	<ol style="list-style-type: none"> 1. Check the management-module event log; if an error was recorded by the system, see "POST progress codes (checkpoints)" on page 71. 2. If no entry is found, replace the system-board and chassis assembly.
A0D-40x	FRU Presence/Detect Error (Mis-Plugged).	<ol style="list-style-type: none"> 1. Check the management-module event log; if an error was recorded by the system, see "POST progress codes (checkpoints)" on page 71. 2. If no entry is found, replace the system-board and chassis assembly.
A10-100	The resource is unavailable due to an error. System is operating in degraded mode.	<ol style="list-style-type: none"> 1. Check the management-module event log; if an error was recorded by the system, see "POST progress codes (checkpoints)" on page 71. 2. If no entry is found, replace the system-board and chassis assembly.
A10-200	The resource was marked failed by the platform. The system is operating in degraded mode.	<ol style="list-style-type: none"> 1. Check the management-module event log; if an error was recorded by the system, see "POST progress codes (checkpoints)" on page 71. 2. If no entry is found, replace the system-board and chassis assembly.

SRN	Description	FRU/action
A10-210	The processor has been deconfigured. The system is operating in degraded mode.	<ol style="list-style-type: none"> 1. Check the management-module event log; if an error was recorded by the system, see "POST progress codes (checkpoints)" on page 71. 2. If no entry is found, replace the system-board and chassis assembly.
A11-00x	A non-critical error has been detected. Error log analysis indicates an error detected by the microprocessor, but the failure could not be isolated.	<ol style="list-style-type: none"> 1. Check the management-module event log; if an error was recorded by the system, see "POST progress codes (checkpoints)" on page 71. 2. If no entry is found, replace the system-board and chassis assembly.
A11-01x	A non-critical error has been detected, a CPU internal error.	<ol style="list-style-type: none"> 1. Check the management-module event log; if an error was recorded by the system, see "POST progress codes (checkpoints)" on page 71. 2. If no entry is found, replace the system-board and chassis assembly.
A11-02x	A non-critical error has been detected, a CPU internal cache or cache controller error.	<ol style="list-style-type: none"> 1. Check the management-module event log; if an error was recorded by the system, see "POST progress codes (checkpoints)" on page 71. 2. If no entry is found, replace the system-board and chassis assembly.
A11-03x	A non-critical error has been detected, an external cache parity or multi-bit ECC error.	<ol style="list-style-type: none"> 1. Check the management-module event log; if an error was recorded by the system, see "POST progress codes (checkpoints)" on page 71. 2. If no entry is found, see "Solving undetermined problems" on page 194.
A11-05x	A non-critical error has been detected, a system bus time-out error.	<ol style="list-style-type: none"> 1. Check the management-module event log; if an error was recorded by the system, see "POST progress codes (checkpoints)" on page 71. 2. If no entry is found, replace the system-board and chassis assembly.
A11-06x	A non-critical error has been detected, a time-out error waiting for an I/O device.	Check the management-module event log for an entry around this time. If no entry is found, replace the system-board and chassis assembly.
A11-50x	Recoverable errors on resource indicate a trend toward an unrecoverable error. However, the resource could not be deconfigured and is still in use. The system is operating with the potential for an unrecoverable error.	<ol style="list-style-type: none"> 1. If repair is not immediately available, reboot and the resource will be deconfigured; operations can continue in a degraded mode. 2. Check the management-module event log for an entry around this time. If no entry is found, replace the system-board and chassis assembly.
A11-510	Resource has been deconfigured and is no longer in use due to a trend toward an unrecoverable error.	<ol style="list-style-type: none"> 1. Schedule maintenance; the system is operating in a degraded mode. 2. Check the management-module event log for an entry around this time. If no entry is found, replace the system-board and chassis assembly.
A11-540	Recoverable errors on resource indicate a trend toward an unrecoverable error. However, the resource could not be deconfigured and is still in use. The system is operating with the potential for an unrecoverable error.	<ol style="list-style-type: none"> 1. If repair is not immediately available, reboot and the resource will be deconfigured; operations can continue in a degraded mode. 2. Check the management-module event log for an entry around this time. If no entry is found, replace the system-board and chassis assembly.
A11-550	Recoverable errors on resource indicate a trend toward an unrecoverable error. However, the resource could not be deconfigured and is still in use. The system is operating with the potential for an unrecoverable error.	<ol style="list-style-type: none"> 1. If repair is not immediately available, reboot and the resource will be deconfigured; operations can continue in a degraded mode. 2. Check the management-module event log for an entry around this time. If no entry is found, replace the system-board and chassis assembly.
A12-00x	A non-critical error has been detected. Error log analysis indicates an error detected by the memory controller, but the failure could not be isolated.	<ol style="list-style-type: none"> 1. Check the management-module event log; if an error was recorded by the system, see "POST progress codes (checkpoints)" on page 71. 2. If no entry is found, replace the system-board and chassis assembly.

SRN	Description	FRU/action
A12-01x	A non-critical error has been detected, an uncorrectable memory error.	<ol style="list-style-type: none"> 1. Check the management-module event log; if an error was recorded by the system, see "POST progress codes (checkpoints)" on page 71. 2. If no entry is found, replace the system-board and chassis assembly.
A12-02x	A non-critical error has been detected, an ECC correctable error.	<ol style="list-style-type: none"> 1. Check the management-module event log; if an error was recorded by the system, see "POST progress codes (checkpoints)" on page 71. 2. If no entry is found, replace the system-board and chassis assembly.
A12-03x	A non-critical error has been detected, a correctable error threshold exceeded.	<ol style="list-style-type: none"> 1. Check the management-module event log; if an error was recorded by the system, see "POST progress codes (checkpoints)" on page 71. 2. If no entry is found, replace the system-board and chassis assembly.
A12-04x	A non-critical error has been detected, a memory control subsystem internal error.	<ol style="list-style-type: none"> 1. Check the management-module event log; if an error was recorded by the system, see "POST progress codes (checkpoints)" on page 71. 2. If no entry is found, replace the system-board and chassis assembly.
A12-05x	A non-critical error has been detected, a memory address error (invalid address or access attempt).	<ol style="list-style-type: none"> 1. Check the management-module event log; if an error was recorded by the system, see "POST progress codes (checkpoints)" on page 71. 2. If no entry is found, replace the system-board and chassis assembly.
A12-06x	A non-critical error has been detected, a memory data error (bad data going to memory).	<ol style="list-style-type: none"> 1. Check the management-module event log; if an error was recorded by the system, see "POST progress codes (checkpoints)" on page 71. 2. If no entry is found, replace the system-board and chassis assembly.
A12-07x	A non-critical error has been detected, a memory bus/switch internal error.	<ol style="list-style-type: none"> 1. Check the management-module event log; if an error was recorded by the system, see "POST progress codes (checkpoints)" on page 71. 2. If no entry is found, replace the system-board and chassis assembly.
A12-08x	A non-critical error has been detected, a memory time-out error.	<ol style="list-style-type: none"> 1. Check the management-module event log; if an error was recorded by the system, see "POST progress codes (checkpoints)" on page 71. 2. If no entry is found, replace the system-board and chassis assembly.
A12-09x	A non-critical error has been detected, a system bus parity error.	<ol style="list-style-type: none"> 1. Check the management-module event log; if an error was recorded by the system, see "POST progress codes (checkpoints)" on page 71. 2. If no entry is found, replace the system-board and chassis assembly.
A12-10x	A non-critical error has been detected, a system bus time-out error.	<ol style="list-style-type: none"> 1. Check the management-module event log; if an error was recorded by the system, see "POST progress codes (checkpoints)" on page 71. 2. If no entry is found, replace the system-board and chassis assembly.
A12-11x	A non-critical error has been detected, a system bus protocol/transfer error.	<ol style="list-style-type: none"> 1. Check the management-module event log; if an error was recorded by the system, see "POST progress codes (checkpoints)" on page 71. 2. If no entry is found, replace the system-board and chassis assembly.
A12-12x	A non-critical error has been detected, an I/O host bridge time-out error.	<ol style="list-style-type: none"> 1. Check the management-module event log; if an error was recorded by the system, see "POST progress codes (checkpoints)" on page 71. 2. If no entry is found, replace the system-board and chassis assembly.

SRN	Description	FRU/action
A12-13x	A non-critical error has been detected, a I/O host bridge address/data parity error.	<ol style="list-style-type: none"> 1. Check the management-module event log; if an error was recorded by the system, see "POST progress codes (checkpoints)" on page 71. 2. If no entry is found, replace the system-board and chassis assembly.
A12-15x	A non-critical error has been detected, a system support function error.	<ol style="list-style-type: none"> 1. Check the management-module event log; if an error was recorded by the system, see "POST progress codes (checkpoints)" on page 71. 2. If no entry is found, replace the system-board and chassis assembly.
A12-16x	A non-critical error has been detected, a system bus internal hardware/switch error.	<ol style="list-style-type: none"> 1. Check the management-module event log; if an error was recorded by the system, see "POST progress codes (checkpoints)" on page 71. 2. If no entry is found, replace the system-board and chassis assembly.
A12-50x	<p>Recoverable errors on resource indicate a trend toward an unrecoverable error.</p> <p>However, the resource could not be deconfigured and is still in use.</p> <p>The system is operating with the potential for an unrecoverable error.</p>	<ol style="list-style-type: none"> 1. If repair is not immediately available, reboot and the resource will be deconfigured; operations can continue in a degraded mode. 2. Check the management-module event log for an entry around this time. If no entry is found, replace the system-board and chassis assembly.
A13-00x	A non-critical error has been detected, a error log analysis indicates an error detected by the I/O device, but the failure could not be isolated.	<ol style="list-style-type: none"> 1. Check the management-module event log; if an error was recorded by the system, see "POST progress codes (checkpoints)" on page 71. 2. If no entry is found, replace the system-board and chassis assembly.
A13-01x	A non-critical error has been detected, an I/O bus address parity error.	<ol style="list-style-type: none"> 1. Check the management-module event log; if an error was recorded by the system, see "POST progress codes (checkpoints)" on page 71. 2. If no entry is found, replace the system-board and chassis assembly.
A13-02x	A non-critical error has been detected, an I/O bus data parity error.	<ol style="list-style-type: none"> 1. Check the management-module event log; if an error was recorded by the system, see "POST progress codes (checkpoints)" on page 71. 2. If no entry is found, replace the system-board and chassis assembly.
A13-03x	A non-critical error has been detected, an I/O bus time-out, access or other error.	<ol style="list-style-type: none"> 1. Check the management-module event log; if an error was recorded by the system, see "POST progress codes (checkpoints)" on page 71. 2. If no entry is found, replace the system-board and chassis assembly.
A13-04x	A non-critical error has been detected, an I/O bridge/device internal error.	<ol style="list-style-type: none"> 1. Check the management-module event log; if an error was recorded by the system, see "POST progress codes (checkpoints)" on page 71. 2. If no entry is found, replace the system-board and chassis assembly.
A13-05x	A non-critical error has been detected, an I/O error on non-PCI bus.	<ol style="list-style-type: none"> 1. Check the management-module event log; if an error was recorded by the system, see "POST progress codes (checkpoints)" on page 71. 2. If no entry is found, replace the system-board and chassis assembly.
A13-06x	A non-critical error has been detected, a mezzanine bus address parity error.	<ol style="list-style-type: none"> 1. Check the management-module event log; if an error was recorded by the system, see "POST progress codes (checkpoints)" on page 71. 2. If no entry is found, replace the system-board and chassis assembly.
A13-07x	A non-critical error has been detected, a system bus address parity error.	<ol style="list-style-type: none"> 1. Check the management-module event log; if an error was recorded by the system, see "POST progress codes (checkpoints)" on page 71. 2. If no entry is found, replace the system-board and chassis assembly.

SRN	Description	FRU/action
A13-09x	A non-critical error has been detected, a system bus data parity error.	<ol style="list-style-type: none"> 1. Check the management-module event log; if an error was recorded by the system, see "POST progress codes (checkpoints)" on page 71. 2. If no entry is found, replace the system-board and chassis assembly.
A13-11x	A non-critical error has been detected, a system bus time-out error	<ol style="list-style-type: none"> 1. Check the management-module event log; if an error was recorded by the system, see "POST progress codes (checkpoints)" on page 71. 2. If no entry is found, replace the system-board and chassis assembly.
A13-12x	A non-critical error has been detected, an error on system bus.	<ol style="list-style-type: none"> 1. Check the management-module event log; if an error was recorded by the system, see "POST progress codes (checkpoints)" on page 71. 2. If no entry is found, replace the system-board and chassis assembly.
A13-13x	A non-critical error has been detected, an I/O expansion bus parity error.	<ol style="list-style-type: none"> 1. Check the management-module event log; if an error was recorded by the system, see "POST progress codes (checkpoints)" on page 71. 2. If no entry is found, replace the system-board and chassis assembly.
A13-14x	A non-critical error has been detected, an I/O expansion bus time-out error.	<ol style="list-style-type: none"> 1. Check the management-module event log; if an error was recorded by the system, see "POST progress codes (checkpoints)" on page 71. 2. If no entry is found, replace the system-board and chassis assembly.
A13-15x	A non-critical error has been detected, an I/O expansion bus connection failure.	<ol style="list-style-type: none"> 1. Check the management-module event log; if an error was recorded by the system, see "POST progress codes (checkpoints)" on page 71. 2. If no entry is found, replace the system-board and chassis assembly.
A13-16x	A non-critical error has been detected, an I/O expansion unit not in an operating state.	<ol style="list-style-type: none"> 1. Check the management-module event log; if an error was recorded by the system, see "POST progress codes (checkpoints)" on page 71. 2. If no entry is found, replace the system-board and chassis assembly.
A13-50x	<p>Recoverable errors on resource indicate a trend toward an unrecoverable error.</p> <p>However, the resource could not be deconfigured and is still in use. The system is operating with the potential for an unrecoverable error.</p>	<ol style="list-style-type: none"> 1. If repair is not immediately available, reboot and the resource will be deconfigured; operations can continue in a degraded mode. 2. Check the management-module event log for an entry around this time. If no entry is found, replace the system-board and chassis assembly.
A15-01x	Sensor indicates a fan is turning too slowly.	<ol style="list-style-type: none"> 1. Check the management-module event log; if an error was recorded by the system, see "POST progress codes (checkpoints)" on page 71. 2. If no entry is found, replace the system-board and chassis assembly.
A15-03x	Sensor indicates a voltage outside normal range.	<ol style="list-style-type: none"> 1. Check the management-module event log; if an error was recorded by the system, see "POST progress codes (checkpoints)" on page 71. 2. If no entry is found, replace the system-board and chassis assembly.
A15-05x	Sensor indicates an abnormally high internal temperature.	<ol style="list-style-type: none"> 1. Make sure that: <ol style="list-style-type: none"> a. The room ambient temperature is within the system operating environment. b. There is unrestricted air flow around the system. c. All system covers are closed. d. There are no fan failures 2. Check the management-module event log; if an error was recorded by the system, see "POST progress codes (checkpoints)" on page 71. 3. If no entry is found, replace the system-board and chassis assembly.

SRN	Description	FRU/action
A15-07x	Sensor indicates a power supply has failed.	<ol style="list-style-type: none"> 1. Check the management-module event log; if an error was recorded by the system, see "POST progress codes (checkpoints)" on page 71. 2. If no entry is found, replace the system-board and chassis assembly.
A15-11x	Sensor detected a redundant fan failure.	<ol style="list-style-type: none"> 1. Check the management-module event log; if an error was recorded by the system, see "POST progress codes (checkpoints)" on page 71. 2. If no entry is found, replace the system-board and chassis assembly.
A15-12x	Sensor detected redundant power supply failure.	<ol style="list-style-type: none"> 1. Check the management-module event log; if an error was recorded by the system, see "POST progress codes (checkpoints)" on page 71. 2. If no entry is found, replace the system-board and chassis assembly.
A15-13x	Sensor detected a redundant FRU that has failed.	<ol style="list-style-type: none"> 1. Check the management-module event log; if an error was recorded by the system, see "POST progress codes (checkpoints)" on page 71. 2. If no entry is found, replace the system-board and chassis assembly.
A15-14x	Power fault due to unspecified cause.	<ol style="list-style-type: none"> 1. Check the management-module event log; if an error was recorded by the system, see "POST progress codes (checkpoints)" on page 71. 2. If no entry is found, replace the system-board and chassis assembly.
A15-17x	Internal redundant power supply failure.	<ol style="list-style-type: none"> 1. Check the management-module event log; if an error was recorded by the system, see "POST progress codes (checkpoints)" on page 71. 2. If no entry is found, replace the system-board and chassis assembly.
A15-19x	Fan failure.	<ol style="list-style-type: none"> 1. Check the management-module event log; if an error was recorded by the system, see "POST progress codes (checkpoints)" on page 71. 2. If no entry is found, replace the system-board and chassis assembly.
A15-20x	Non-critical cooling problem, loss of redundant fan.	<ol style="list-style-type: none"> 1. Check the management-module event log; if an error was recorded by the system, see "POST progress codes (checkpoints)" on page 71. 2. If no entry is found, replace the system-board and chassis assembly.
A15-21x	Over temperature condition.	<ol style="list-style-type: none"> 1. Make sure that: <ol style="list-style-type: none"> a. The room ambient temperature is within the system operating environment. b. There is unrestricted air flow around the system. c. All system covers are closed. d. There are no fan failures 2. Check the management-module event log; if an error was recorded by the system, see "POST progress codes (checkpoints)" on page 71. 3. If no entry is found, replace the system-board and chassis assembly.
A15-22x	Fan failure and Over temperature condition.	<ol style="list-style-type: none"> 1. Check the management-module event log; if an error was recorded by the system, see "POST progress codes (checkpoints)" on page 71. 2. If no entry is found, replace the system-board and chassis assembly.
A15-23x	Non-critical power problem, loss of redundant power supply.	<ol style="list-style-type: none"> 1. Check the management-module event log; if an error was recorded by the system, see "POST progress codes (checkpoints)" on page 71. 2. If no entry is found, replace the system-board and chassis assembly.

SRN	Description	FRU/action
A15-24x	Power Fault specifically due to internal battery failure.	<ol style="list-style-type: none"> 1. Check the management-module event log; if an error was recorded by the system, see "POST progress codes (checkpoints)" on page 71. 2. If no entry is found, replace the system-board and chassis assembly.
A15-50x	<p>Recoverable errors on resource indicate a trend toward an unrecoverable error.</p> <p>However, the resource could not be deconfigured and is still in use.</p> <p>The system is operating with the potential for an unrecoverable error.</p>	<ol style="list-style-type: none"> 1. If repair is not immediately available, reboot and the resource will be deconfigured; operations can continue in a degraded mode. 2. Check the management-module event log; if an error was recorded by the system, see "POST progress codes (checkpoints)" on page 71. 3. If no entry is found, replace the system-board and chassis assembly.
A1D-00x	A non-critical error has been detected. Error log analysis indicates an error detected by the Service Processor, but the failure could not be isolated.	<ol style="list-style-type: none"> 1. Check the management-module event log; if an error was recorded by the system, see "POST progress codes (checkpoints)" on page 71. 2. If no entry is found, replace the system-board and chassis assembly.
A1D-02x	A non-critical error has been detected, an I/O (I2C) general bus error.	<ol style="list-style-type: none"> 1. Check the management-module event log; if an error was recorded by the system, see "POST progress codes (checkpoints)" on page 71. 2. If no entry is found, replace the system-board and chassis assembly.
A1D-04x	A non-critical error has been detected, an internal service processor memory error.	<ol style="list-style-type: none"> 1. Check the management-module event log; if an error was recorded by the system, see "POST progress codes (checkpoints)" on page 71. 2. If no entry is found, replace the system-board and chassis assembly.
A1D-05x	A non-critical error has been detected, a service processor error accessing special registers.	<ol style="list-style-type: none"> 1. Check the management-module event log; if an error was recorded by the system, see "POST progress codes (checkpoints)" on page 71. 2. If no entry is found, replace the system-board and chassis assembly.
A1D-06x	A non-critical error has been detected, a service processor reports unknown communication error.	<ol style="list-style-type: none"> 1. Check the management-module event log; if an error was recorded by the system, see "POST progress codes (checkpoints)" on page 71. 2. If no entry is found, replace the system-board and chassis assembly.
A1D-07x	A non-critical error has been detected: Internal service processor firmware error or incorrect version.	<ol style="list-style-type: none"> 1. Check the management-module event log; if an error was recorded by the system, see "POST progress codes (checkpoints)" on page 71. 2. If no entry is found, replace the system-board and chassis assembly.
A1D-08x	A non-critical error has been detected, another internal service processor hardware error.	<ol style="list-style-type: none"> 1. Check the management-module event log; if an error was recorded by the system, see "POST progress codes (checkpoints)" on page 71. 2. If no entry is found, replace the system-board and chassis assembly.
A1D-09x	A non-critical error has been detected, a service processor error accessing vital product data EEPROM.	<ol style="list-style-type: none"> 1. Check the management-module event log; if an error was recorded by the system, see "POST progress codes (checkpoints)" on page 71. 2. If no entry is found, replace the system-board and chassis assembly.
A1D-12x	A non-critical error has been detected, a service processor error accessing fan sensor.	<ol style="list-style-type: none"> 1. Check the management-module event log; if an error was recorded by the system, see "POST progress codes (checkpoints)" on page 71. 2. If no entry is found, replace the system-board and chassis assembly.

SRN	Description	FRU/action
A1D-13x	A non-critical error has been detected, a service processor error accessing a thermal sensor.	<ol style="list-style-type: none"> 1. Check the management-module event log; if an error was recorded by the system, see "POST progress codes (checkpoints)" on page 71. 2. If no entry is found, replace the system-board and chassis assembly.
A1D-18x	A non-critical error has been detected, a service processor detected NVRAM error.	<ol style="list-style-type: none"> 1. Check the management-module event log; if an error was recorded by the system, see "POST progress codes (checkpoints)" on page 71. 2. If no entry is found, replace the system-board and chassis assembly.
A1D-19x	A non-critical error has been detected, a service processor error accessing real time clock/time-of-day clock.	<ol style="list-style-type: none"> 1. Check the management-module event log; if an error was recorded by the system, see "POST progress codes (checkpoints)" on page 71. 2. If no entry is found, replace the system-board and chassis assembly.
A1D-20x	A non-critical error has been detected: Service processor error accessing scan controller/hardware.	<ol style="list-style-type: none"> 1. Check the management-module event log; if an error was recorded by the system, see "POST progress codes (checkpoints)" on page 71. 2. If no entry is found, replace the system-board and chassis assembly.
A1D-21x	A non-critical error has been detected, a service processor detected error with time-of-day clock backup battery.	<ol style="list-style-type: none"> 1. Check the management-module event log; if an error was recorded by the system, see "POST progress codes (checkpoints)" on page 71. 2. If no entry is found, replace the system-board and chassis assembly.
A1D-23x	A non-critical error has been detected: Loss of heart beat from Service Processor.	<ol style="list-style-type: none"> 1. Check the management-module event log; if an error was recorded by the system, see "POST progress codes (checkpoints)" on page 71. 2. If no entry is found, replace the system-board and chassis assembly.
A1D-24x	A non-critical error has been detected, a service processor detected a surveillance time-out.	<ol style="list-style-type: none"> 1. Check the management-module event log; if an error was recorded by the system, see "POST progress codes (checkpoints)" on page 71. 2. If no entry is found, replace the system-board and chassis assembly.
A1D-29x	A non-critical error has been detected, a service process error accessing power control network.	<ol style="list-style-type: none"> 1. Check the management-module event log; if an error was recorded by the system, see "POST progress codes (checkpoints)" on page 71. 2. If no entry is found, replace the system-board and chassis assembly.
A1D-30x	A non-critical error has been detected: Non-supported hardware.	<ol style="list-style-type: none"> 1. Check the management-module event log; if an error was recorded by the system, see "POST progress codes (checkpoints)" on page 71. 2. If no entry is found, replace the system-board and chassis assembly.
A1D-31x	A non-critical error has been detected: Error detected while handling an attention/interrupt from the system hardware.	<ol style="list-style-type: none"> 1. Check the management-module event log; if an error was recorded by the system, see "POST progress codes (checkpoints)" on page 71. 2. If no entry is found, replace the system-board and chassis assembly.
A1D-34x	A non-critical error has been detected: Wire Test Error.	<ol style="list-style-type: none"> 1. Check the management-module event log; if an error was recorded by the system, see "POST progress codes (checkpoints)" on page 71. 2. If no entry is found, replace the system-board and chassis assembly.

SRN	Description	FRU/action
A1D-35x	A non-critical error has been detected: Mainstore or Cache IPL Diagnostic Error.	<ol style="list-style-type: none"> 1. Check the management-module event log; if an error was recorded by the system, see "POST progress codes (checkpoints)" on page 71. 2. If no entry is found, replace the system-board and chassis assembly.
A1D-37x	A non-critical error has been detected: Clock or PLL Error.	<ol style="list-style-type: none"> 1. Check the management-module event log; if an error was recorded by the system, see "POST progress codes (checkpoints)" on page 71. 2. If no entry is found, replace the system-board and chassis assembly.
A1D-38x	A non-critical error has been detected: Hardware Scan or Initialization Error.	<ol style="list-style-type: none"> 1. Check the management-module event log; if an error was recorded by the system, see "POST progress codes (checkpoints)" on page 71. 2. If no entry is found, replace the system-board and chassis assembly.
A1D-40x	A non-critical error has been detected: Presence/Detect Error (Mis-Plugged).	<ol style="list-style-type: none"> 1. Check the management-module event log; if an error was recorded by the system, see "POST progress codes (checkpoints)" on page 71. 2. If no entry is found, replace the system-board and chassis assembly.
A1D-50x	<p>Recoverable errors on resource indicate a trend toward an unrecoverable error.</p> <p>However, the resource could not be deconfigured and is still in use. The system is operating with the potential for an unrecoverable error.</p>	<ol style="list-style-type: none"> 1. If repair is not immediately available, reboot and the resource will be deconfigured; operations can continue in a degraded mode. 2. Check the management-module event log; if an error was recorded by the system, see "POST progress codes (checkpoints)" on page 71. 3. If no entry is found, replace the system-board and chassis assembly.
A24-000	Spurious interrupts on shared interrupt level have exceeded threshold	<ol style="list-style-type: none"> 1. Check the management-module event log. If an error was recorded by the system, see "POST progress codes (checkpoints)" on page 71. 2. Replace part numbers reported by the diagnostic program. 3. If no entry is found, replace the system-board and chassis assembly.
A24-xxx	Spurious interrupts have exceeded threshold.	<ol style="list-style-type: none"> 1. Check the management-module event log; if an error was recorded by the system, see "POST progress codes (checkpoints)" on page 71. 2. Replace part numbers reported by the diagnostic program. 3. If no entry is found, replace the system-board and chassis assembly.

2.4.3.4 SCSD devices SRNs (ssss-102 through ssss-640)

These service request numbers (SRNs) identify a SCSD (Self-Configuring SCSI Device) problem.

Use *Table 2-25* to identify an SRN when you suspect a SAS hard disk or Solid State Disk (SSD) device problem. Replace the parts in the order that the failing function codes (FFCs) are listed.

-
- Notes**
- Some SRNs might have 4 digits rather than 3 digits after the dash (-).
 - The ssss before the dash (-) represents the 3 digit or 4 digit SCSI SRN.
-

Table 2-25. ssss-102 through ssss-640 SRNs

SRN	FFC	Description and action
ssss-102	ssss	An unrecoverable media error occurred. 1. Check the management-module event log. If an error was recorded by the system, see <i>"POST progress codes (checkpoints)"</i> on page 71. 2. Replace any parts reported by the diagnostic program. 3. Replace the system board and chassis assembly, as described in <i>"Replacing the Tier 2 system-board and chassis assembly"</i> on page 229.
ssss-104	ssss	The motor failed to restart. 1. Check the management-module event log. If an error was recorded by the system, see <i>"POST progress codes (checkpoints)"</i> on page 71. 2. Replace any parts reported by the diagnostic program. 3. Replace the system board and chassis assembly, as described in <i>"Replacing the Tier 2 system-board and chassis assembly"</i> on page 229.
ssss-105	ssss	The drive did not become ready. 1. Check the management-module event log. If an error was recorded by the system, see <i>"POST progress codes (checkpoints)"</i> on page 71. 2. Replace any parts reported by the diagnostic program. 3. Replace the system board and chassis assembly, as described in <i>"Replacing the Tier 2 system-board and chassis assembly"</i> on page 229.
ssss-106	ssss	The electronics card test failed. 1. Check the management-module event log. If an error was recorded by the system, see <i>"POST progress codes (checkpoints)"</i> on page 71. 2. Replace any parts reported by the diagnostic program. 3. Replace the system board and chassis assembly, as described in <i>"Replacing the Tier 2 system-board and chassis assembly"</i> on page 229.
ssss-108	ssss	The bus test failed. 1. Check the management-module event log. If an error was recorded by the system, see <i>"POST progress codes (checkpoints)"</i> on page 71. 2. Replace any parts reported by the diagnostic program. 3. Replace the system board and chassis assembly, as described in <i>"Replacing the Tier 2 system-board and chassis assembly"</i> on page 229.

SRN	FFC	Description and action
ssss-110	ssss	The media format is corrupted. <ol style="list-style-type: none"> 1. Check the management-module event log. If an error was recorded by the system, see <i>"POST progress codes (checkpoints)"</i> on page 71. 2. Replace any parts reported by the diagnostic program. 3. Replace the system board and chassis assembly, as described in <i>"Replacing the Tier 2 system-board and chassis assembly"</i> on page 229.
ssss-112	ssss	The diagnostic test failed. <ol style="list-style-type: none"> 1. Check the management-module event log. If an error was recorded by the system, see <i>"POST progress codes (checkpoints)"</i> on page 71. 2. Replace any parts reported by the diagnostic program. 3. Replace the system board and chassis assembly, as described in <i>"Replacing the Tier 2 system-board and chassis assembly"</i> on page 229.
ssss-114	ssss	An unrecoverable hardware error. <ol style="list-style-type: none"> 1. Check the management-module event log. If an error was recorded by the system, see <i>"POST progress codes (checkpoints)"</i> on page 71. 2. Replace any parts reported by the diagnostic program. 3. Replace the system board and chassis assembly, as described in <i>"Replacing the Tier 2 system-board and chassis assembly"</i> on page 229.
ssss-116	Ssss	A protocol error. <ol style="list-style-type: none"> 1. Make sure that the device, adapter and diagnostic firmware, and the application software levels are compatible. 2. If you do not find a problem, call your operating-system support person.
ssss-117	ssss	A write-protect error occurred. <ol style="list-style-type: none"> 1. Check the management-module event log. If an error was recorded by the system, see <i>"POST progress codes (checkpoints)"</i> on page 71. 2. Replace any parts reported by the diagnostic program. 3. Replace the system board and chassis assembly, as described in <i>"Replacing the Tier 2 system-board and chassis assembly"</i> on page 229.
ssss-118	ssss 252B	A SCSD command time-out occurred. <ol style="list-style-type: none"> 1. Check the management-module event log. If an error was recorded by the system, see <i>"POST progress codes (checkpoints)"</i> on page 71. 2. Replace any parts reported by the diagnostic program. 3. Replace the system board and chassis assembly, as described in <i>"Replacing the Tier 2 system-board and chassis assembly"</i> on page 229.
ssss-120	ssss	A SCSD busy or command error. <ol style="list-style-type: none"> 1. Check the management-module event log. If an error was recorded by the system, see <i>"POST progress codes (checkpoints)"</i> on page 71. 2. Replace any parts reported by the diagnostic program. 3. Replace the system board and chassis assembly, as described in <i>"Replacing the Tier 2 system-board and chassis assembly"</i> on page 229.
ssss-122	ssss	A SCSD reservation conflict error. <ol style="list-style-type: none"> 1. Check the management-module event log. If an error was recorded by the system, see <i>"POST progress codes (checkpoints)"</i> on page 71. 2. Replace any parts reported by the diagnostic program. 3. Replace the system board and chassis assembly, as described in <i>"Replacing the Tier 2 system-board and chassis assembly"</i> on page 229.
ssss-124	ssss	A SCSD check condition error occurred. <ol style="list-style-type: none"> 1. Check the management-module event log. If an error was recorded by the system, see <i>"POST progress codes (checkpoints)"</i> on page 71. 2. Replace any parts reported by the diagnostic program. 3. Replace the system board and chassis assembly, as described in <i>"Replacing the Tier 2 system-board and chassis assembly"</i> on page 229.

SRN	FFC	Description and action
ssss-126	ssss 252B	A software error was caused by a hardware failure. <ol style="list-style-type: none"> 1. Check the management-module event log. If an error was recorded by the system, see <i>"POST progress codes (checkpoints)"</i> on page 71. 2. Replace any parts reported by the diagnostic program. 3. Replace the system board and chassis assembly, as described in <i>"Replacing the Tier 2 system-board and chassis assembly"</i> on page 229.
ssss-128	252B ssss software	The error log analysis indicates a hardware failure. <ol style="list-style-type: none"> 1. Check the management-module event log. If an error was recorded by the system, see <i>"POST progress codes (checkpoints)"</i> on page 71. 2. Replace any parts reported by the diagnostic program. 3. Replace the system board and chassis assembly, as described in <i>"Replacing the Tier 2 system-board and chassis assembly"</i> on page 229.
ssss-129	252B ssss software	Error log analysis indicates a SCSI bus problem. <ol style="list-style-type: none"> 1. Check the management-module event log. If an error was recorded by the system, see <i>"POST progress codes (checkpoints)"</i> on page 71. 2. Replace any parts reported by the diagnostic program. 3. Replace the system board and chassis assembly, as described in <i>"Replacing the Tier 2 system-board and chassis assembly"</i> on page 229.
ssss-130	ssss	Error log analysis indicates a problem reported by the disk drive's self-monitoring function. <ol style="list-style-type: none"> 1. Check the management-module event log. If an error was recorded by the system, see <i>"POST progress codes (checkpoints)"</i> on page 71. 2. Replace any parts reported by the diagnostic program. 3. Replace the system board and chassis assembly, as described in <i>"Replacing the Tier 2 system-board and chassis assembly"</i> on page 229.
ssss-132	Ssss	A disk drive hardware error occurred. <ol style="list-style-type: none"> 1. Check the management-module event log. If an error was recorded by the system, see <i>"POST progress codes (checkpoints)"</i> on page 71. 2. Replace any parts reported by the diagnostic program. 3. Replace the system board and chassis assembly, as described in <i>"Replacing the Tier 2 system-board and chassis assembly"</i> on page 229.
ssss-134	252B software	The adapter failed to configure. <ol style="list-style-type: none"> 1. Check the management-module event log. If an error was recorded by the system, see <i>"POST progress codes (checkpoints)"</i> on page 71. 2. Replace any parts reported by the diagnostic program. 3. Replace the system board and chassis assembly, as described in <i>"Replacing the Tier 2 system-board and chassis assembly"</i> on page 229.
ssss-135	ssss 252B software	The device failed to configure. <ol style="list-style-type: none"> 1. Check the management-module event log. If an error was recorded by the system, see <i>"POST progress codes (checkpoints)"</i> on page 71. 2. Replace any parts reported by the diagnostic program. 3. Replace the system board and chassis assembly, as described in <i>"Replacing the Tier 2 system-board and chassis assembly"</i> on page 229.
ssss-136	ssss	The certify operation failed. <ol style="list-style-type: none"> 1. Check the management-module event log. If an error was recorded by the system, see <i>"POST progress codes (checkpoints)"</i> on page 71. 2. Replace any parts reported by the diagnostic program. 3. Replace the system board and chassis assembly, as described in <i>"Replacing the Tier 2 system-board and chassis assembly"</i> on page 229.

SRN	FFC	Description and action
ssss-137	ssss 252B	Unit attention condition has occurred on the <i>Send Diagnostic</i> command. 1. Check the management-module event log. If an error was recorded by the system, see <i>"POST progress codes (checkpoints)"</i> on page 71. 2. Replace any parts reported by the diagnostic program. 3. Replace the system board and chassis assembly, as described in <i>"Replacing the Tier 2 system-board and chassis assembly"</i> on page 229.
ssss-138	ssss	Error log analysis indicates that the disk drive is operating at a higher than recommended temperature. 1. Make sure that: <ul style="list-style-type: none"> – The ventilation holes in the blade server bezel are not blocked. – The management-module event log is not reporting any system environmental warnings. 2. If the problem remains, call Bull support.
ssss-140	199 252B ssss	Error log analysis indicates poor signal quality. 1. Check the management-module event log. If an error was recorded by the system, see <i>"POST progress codes (checkpoints)"</i> on page 71. 2. Replace any parts reported by the diagnostic program. 3. Replace the system board and chassis assembly, as described in <i>"Replacing the Tier 2 system-board and chassis assembly"</i> on page 229.
ssss-640	ssss	Error log analysis indicates a path error. 1. Check the management-module event log. If an error was recorded by the system, see <i>"POST progress codes (checkpoints)"</i> on page 71. 2. Replace any parts reported by the diagnostic program. 3. Replace the system board and chassis assembly, as described in <i>"Replacing the Tier 2 system-board and chassis assembly"</i> on page 229.

2.4.3.5 Failing function codes 151 through 2D02

Failing function codes (FFCs) identify a function within the system unit that is failing.

Table 26 describes the component that each function code identifies.

Note: When replacing a component, perform system verification for the component. See *"Using the diagnostics program"* on page 155.

Table 2-26. Failing function codes 151 through 2D02

FFC	Description and notes
151	1. Battery Note: After replacing the battery: <ol style="list-style-type: none"> a. Set the time and date. b. Set the Network IP addresses (for blade servers that start up from a network). 2. System-board and chassis assembly
152	System-board and chassis assembly
166	Check management-module event log for a blower or fan fault. See the documentation that comes with the Bull Blade Chassis - Enterprise.
210	System-board and chassis assembly
212	System-board and chassis assembly (cache problem)

FFC	Description and notes
214	System-board and chassis assembly
217	System-board and chassis assembly
219	Common Memory Logic problem for memory DIMMs. Note: If more than one pair of memory DIMMs are reported missing: 1. Replace the system-board and chassis assembly 2. Replace the memory DIMM at the physical location code that is reported
221	System-board and chassis assembly
226	System-board and chassis assembly
227	System-board and chassis assembly
241	Ethernet network problem
282	System-board and chassis assembly
292	System-board and chassis assembly (Host – PCI bridge problem)
293	System-board and chassis assembly (PCI – PCI bridge problem)
294	System-board and chassis assembly (MPIC interrupt controller problem)
296	PCI device or adapter problem. Note: The replacement part can only be identified by the location code reported by diagnostics.
2C4	System-board and chassis assembly
2C6	1 GB DIMM 2 GB DIMM 4 GB DIMM 8 GB DIMM
2C7	System-board and chassis assembly (Memory controller)
2C8	System-board and chassis assembly
2C9	System-board and chassis assembly
2D2	System-board and chassis assembly (Bus arbiter problem)
2D3	System-board and chassis assembly
2D4	System-board and chassis assembly (System/SP interface logic problem)
2D5	System-board and chassis assembly (I2C primary)
2D6	System-board and chassis assembly (I2C secondary)
2D7	System-board and chassis assembly (VPD module)
2D9	System-board and chassis assembly (Power controller)
2E0	System-board and chassis assembly (Fan sensor problem)
2E1	System-board and chassis assembly (Thermal sensor problem)
2E2	System-board and chassis assembly (Voltage sensor problem)
2E3	System-board and chassis assembly (Serial port controller problem)
2E4	System-board and chassis assembly (JTAG/COP controller problem)
2E8	System-board and chassis assembly (Cache controller)
308	System-board and chassis assembly (I/O bridge problem)
650	Unknown hard disk drive. Note: This FFC indicates that the hard disk drive could not properly configure.
711	Unknown adapter
722	Unknown disk drive

FFC	Description and notes
7C0	System-board and chassis assembly (microprocessor/system interface)
812	System-board and chassis assembly (Common standard adapter logic problem)
814	System-board and chassis assembly (NVRAM problem)
815	System-board and chassis assembly (floating point processor problem)
817	System-board and chassis assembly (time-of-day logic)
820	System-board and chassis assembly (interprocessor related testing problem)
887	System-board and chassis assembly (integrated Ethernet adapter)
893	Vendor LAN adapter
D01	System-board and chassis assembly (cache problem)
E19	System-board and chassis assembly (power supply sensor failed)
252B	System-board and chassis assembly (SAS controller)
2553	SAS 73.4 GB or SAS 146 GB hard disk drive
2567	System-board and chassis assembly (USB integrated adapter)
25A0	System-board and chassis assembly
25C4	Broadcom Ethernet adapter
2607	Emulex 8Gb PCI-Express Fibre Channel Expansion Card
2624	System-board and chassis assembly (InfiniBand Host Channel Adapter)
2631	System-board and chassis assembly
2D02	System-board and chassis assembly (generic USB reference to controller/adapter)
2E12	QLogic 8Gb Fibre Channel Expansion Card, (CFFh/PCIe)
2E13	QLogic 4Gb Fibre Channel 1Xe PCI-Express Expansion Card (CIOv)
2E14	QLogic 8Gb Fibre Channel 1Xe PCI-Express Expansion Card (CIOv)

2.5 Error logs

The power-on self-test (POST), the POWER® Hypervisor™ (PHYP), and the service processor write errors to the Bull Blade Chassis - Enterprise management module event log.

Select the **Monitors** → **Event Log** option in the management module Web interface to view entries that are currently stored in the management-module event log. This log includes entries for events that are detected by the blade servers. The log displays the most recent entries first.

The following table shows the syntax of a nine-word B700xxxx SRC as it might be displayed in the event log of the management module.

The first word of the SRC in this example is the message identifier, **B7001111**. This example numbers each word after the first word to show relative word positions.

The seventh word is the direct select address, which is **77777777** in the example.

Table 2-27. Nine-word system reference code in the management-module event log

Index	Sev	Source	Date/Time	Text
1	E	Blade_05	01/21/2008, 17:15:14	(ESCALA BL460 -BC1BLD5E) SYS F/W: Error. Replace UNKNOWN (5008FECF B7001111 22222222 33333333 44444444 55555555 66666666 77777777 88888888 99999999)

Depending on your operating system and the utilities you have installed, error messages might also be stored in an operating system log. See the documentation that comes with the operating system for more information.

See the *Management Module User's Guide* for more information about the event log.

2.6 Checkout procedure

The checkout procedure is the sequence of tasks that you should follow to diagnose a problem in the blade server.

2.6.1 About the checkout procedure

Review this information before performing the checkout procedure.

- Read “Safety” on page v and the “*Installation guidelines*” on page 201.
- The firmware diagnostic program provides the primary methods of testing the major components of the blade server. If you are not sure whether a problem is caused by the hardware or by the software, you can use the firmware diagnostic program to confirm that the hardware is working correctly. The firmware diagnostic program runs automatically when the blade server is turned on.
- A single problem might cause more than one error message. When this happens, correct the cause of the first error message. The other error messages usually will not occur the next time you run the diagnostic programs.
Exception: If there are multiple error codes or light path diagnostic LEDs that indicate a microprocessor error, the error might be in a microprocessor or in a microprocessor socket. See “*Microprocessor problems*” on page 161 for information about diagnosing microprocessor problems.
- If the blade server hangs on a POST checkpoint, see “*POST progress codes (checkpoints)*” on page 71. If the blade server is halted and no error message is displayed, see “*Troubleshooting tables*” on page 158 and “*Solving undetermined problems*” on page 194. For intermittent problems, check the management-module event log and “*POST progress codes (checkpoints)*” on page 71.
- If the blade server front panel shows no LEDs, verify the blade server status and errors in the management module Web interface; also see “*Solving undetermined problems*” on page 194.
- If device errors occur, see “*Troubleshooting tables*” on page 158.

2.6.2 Performing the checkout procedure

Follow this procedure to perform the checkout.

Step 001

Perform the following steps:

1. Update the firmware to the current level, as described in *"Updating the firmware"* on page 231.
2. You might also have to update the management module firmware.
3. If you did not update the firmware for some reason, power off the blade server for 45 seconds before powering it back on.
4. Establish a SOL session; then continue to Step 002. If the blade server does not start, see *"Troubleshooting tables"* on page 158.

Step 002

Verify that you have looked up each error code or hung checkpoint and attempted the corrective action before going to Step 003:

1. If the firmware hangs on an eight-digit progress code, see *"POST progress codes (checkpoints)"* on page 71.
2. If the firmware records an eight-digit error code, see *"System reference codes (SRCs)"* on page 20.
3. If the AIX operating system records a service request number (SRN), see *"Service request numbers (SRNs)"* on page 109.
4. Check the management-module event log. If an error was recorded by the system, see *"POST progress codes (checkpoints)"* on page 71 or *"System reference codes (SRCs)"* on page 20.
5. If no error was recorded, or if the login prompt appears and you still suspect a problem, continue to Step 003.

Step 003

Is the operating system AIX?

Yes Record any information or messages that may be in the management module event log; then go to Step 005.

No Go to Step 004.

Step 004

Is the operating system Linux?

Yes Record any information or messages that may be in the management module event log; then go to Step 007. If you cannot load the stand-alone *Diagnostics* CD, answer this question *No*.

No Go to “*Solving undetermined problems*” on page 194.

Step 005

Perform the following steps:

Note When possible, run AIX online diagnostics in concurrent mode. AIX online diagnostics perform more functions than the stand-alone diagnostics.

1. Perform the AIX online diagnostics, see “*Starting AIX concurrent diagnostics*” on page 152. Record any diagnostic results and see the “*Service request numbers (SRNs)*” on page 109 to identify the failing component.
Note: When replacing a component, perform system verification for the component. See *Using the diagnostics program*” on page 155.
2. If you cannot perform AIX concurrent online diagnostics, continue to Step 006.

Step 006

Perform the following steps:

1. Use the management-module Web interface to make sure that the device from which you load the stand-alone diagnostics is set as the first device in the blade server boot sequence.
2. Turn off the system unit power and wait 45 seconds before proceeding.
3. Turn on the blade server and establish a SOL session.
4. Check for the following responses:
 - a. Progress codes are recorded in the management-module event log.
 - b. Record any messages or diagnostic information that might be in the log.
5. Load the stand-alone diagnostics. Go to “*Starting stand-alone diagnostics from a CD*” on page 152 or “*Starting stand-alone diagnostics from a NIM server*” on page 153.
6. If you have replaced the failing component, perform system verification for the component. See *Using the diagnostics program*” on page 155.

This ends the AIX procedure.

Step 007

Perform the following steps:

1. Use the management-module Web interface to make sure that the device from which you load the stand-alone diagnostics is set as the first device in the blade server boot sequence.
2. Turn off the blade server and wait 45 seconds before proceeding.
3. Turn on the blade server and establish a SOL session.
4. Check for the following responses:
 - a. Progress codes are recorded in the management-module event log.
 - b. Record any messages or diagnostic information that might be in the log.

Continue with step 008.

Step 008

Load the stand-alone diagnostics. Go to *"Starting stand-alone diagnostics from a CD"* on page 152 or *"Starting stand-alone diagnostics from a NIM server"* on page 153.

Can you load the stand-alone diagnostics?

No Go to *"Solving undetermined problems"* on page 194.

Yes Select the resources to be tested and record any SRNs; then go to *"Service request numbers (SRNs)"* on page 109.

This ends the Linux procedure.

2.7 Verifying the partition configuration

Perform this procedure if there is a configuration problem with the system or a logical partition.

1. Check the processor and memory allocations of the system or the partition.
Processor or memory resources that fail during system startup could cause the startup problem in the partition. Make sure that there are enough functioning processor and memory resources in the system for all the partitions.
2. Check the bus and virtual adapter allocations for the partition. Make sure that the partition has load source and console I/O resources.
3. Make sure that the Boot Mode partition properties are set to Normal.
4. If the problem remains, contact your software service provider for further assistance.

2.8 Running the diagnostics program

You can start or run the diagnostics program from the AIX operating system, from a CD, or from a management server.

2.8.1 Starting AIX concurrent diagnostics

Perform this procedure to start AIX concurrent diagnostics from the AIX operating system.

1. Log in to the AIX operating system as root user, or use the CE login. See *"Creating a CE login"* on page 235 for more information. If you need help, contact the system operator.
2. Type `diag` and press **Enter** at the operating system prompt to start the diagnostics program and display its Function Selection menu. See *"Using the diagnostics program"* on page 155 for more information about running the diagnostics program.
3. When testing is complete, press **F3** until the Diagnostic Operating Instructions panel is displayed, then press **F3** to exit the diagnostic program.

2.8.2 Starting stand-alone diagnostics from a CD

Perform these procedures to start the stand-alone diagnostics from a CD. These procedures can be used if the blade server is running a Linux operating system or if an AIX operating system cannot start the concurrent diagnostics program.

1. Verify with the system administrator and systems users that the blade server may be shut down. Stop all programs; then, shut down the operating system and shut down the blade server. Refer to the documentation that comes with your operating system documentation for information about shutting down the operating system.

2. Press the CD button on the front of the blade server to give it ownership of the Bull Blade Chassis – Enterprise media tray.
3. Using the management module Web interface, make sure that:
 - The blade server firmware is at the latest version.
 - SOL is enabled for the blade server.
 - The CD or DVD drive is selected as the first boot device for the blade server.
4. Insert the stand-alone *Diagnostics* CD into the CD or DVD drive.
5. Turn on the blade server and establish a SOL session.
Note: It can take from 3 to 5 minutes to load the stand-alone diagnostics from the CD. Please be patient.
The screen will display “Please define the System Console.”
6. Type **1** and press **Enter** to continue.
The Diagnostic Operating Instructions screen will display.
7. Press **Enter** to continue.
The Function Selection screen will display. See “Using the diagnostics program” on page 155 for more information about running the diagnostics program.

Note If the Define Terminal screen is displayed, type the terminal type and press Enter. The use of “vs100” as the terminal type is recommended; however, the function keys (F#) may not work. In this case, press Esc and the number in the screen menus. For example, instead of **F3** you can press **Esc** and **3**.

8. When testing is complete, press **F3** until the Diagnostic Operating Instructions screen is displayed; then press **F3** again to exit the diagnostic program.
9. Remove the CD from the CD or DVD drive.

2.8.3 Starting stand-alone diagnostics from a NIM server

Perform this procedure to start the stand-alone diagnostics from a network installation management (NIM) server.

Note Refer to the *Network Installation Management Guide and Reference* for information about configuring the blade server as a NIM server client.

1. Verify with the system administrator and systems users that the blade server can be shut down. Stop all programs; then, shut down the operating system and shut down the blade server. Refer to the documentation that comes with your operating system for information about shutting down the operating system.
2. If the system is running in a full-machine partition, turn on the blade server and establish a SOL session.
3. Perform the following steps to check the NIM server boot settings:
 - a. When the POST menu is displayed, press the 1 key to start the SMS utility.
 - b. From the SMS main menu, select **Setup Remote IPL (Initial Program Load)**.
 - c. From the NIC Adapters menu, select the network adapter that is attached to the NIM server.
 - d. From the Network Parameters menu, select **IP Parameters**.
 - e. Enter the client, server, and gateway IP addresses (if applicable), and enter the subnet mask. If there is no gateway between the NIM server and the client, set the gateway address to 0.0.0.0 See your network administrator to determine if there is a gateway.
 - f. If the NIM server is setup to allow pinging the client system, use the Ping Test option on the Network Parameters menu to verify that the client system can ping the NIM server.

Note If the ping fails, see *"Boot problem resolution"* on page 156; then, follow the steps for network boot problems.

4. When the ping is successful, start the blade server from the NIM server.
5. Establish a SOL session.
If the Diagnostic Operating Instructions screen is displayed, the diagnostics program has started successfully.

Note If the AIX login prompt is displayed, the diagnostics program did not load. See *"Boot problem resolution"* on page 156; then, follow the steps for network boot problems.

6. Press Enter to continue.
The Function Selection screen will display. See *"Using the diagnostics program"* on page 155 for more information about running the diagnostics program.

Note If the Define Terminal screen is displayed, type the terminal type and press Enter. The use of "vs100" as the terminal type is recommended; however, the function keys (F#) may not work. In this case, press Esc and the number in the screen menus. For example, instead of **F3** you can press **Esc** and **3**.

7. When testing is complete, press **F3** until the Diagnostic Operating Instructions screen is displayed; then press **F3** again to exit the diagnostic program.

2.8.4 Using the diagnostics program

Follow the basic procedures for running the diagnostics program.

1. Start the diagnostics from the AIX operating system, from a CD, or from a management server. See *"Starting AIX concurrent diagnostics"* on page 152, *"Starting stand-alone diagnostics from a CD"* on page 152 or *"Starting stand-alone diagnostics from a NIM server"* on page 153.
2. The Function Selection menu is displayed. Use the steps listed to perform one of the following tasks:
 - Problem Determination
 - i. From the Function Selection menu, select **Diagnostic Routines** and press Enter.
 - ii. From the Diagnostic Mode Selection menu, select **Problem Determination**
 - iii. Select the resource to be tested and press **F7=Commit**.
 - iv. Record any results provided and go to *"Service request numbers (SRNs)"* on page 109 to identify the failure and perform the action(s).
 - v. When testing is complete, press **F3** to return to the Diagnostic Selection menu. If you want to run another test, press **F3** again to return to the Function Selection menu.
 - System Verification
 - i. From the Function Selection menu, select **Diagnostic Routines** and press Enter.
 - ii. From the Diagnostic Mode Selection menu, select **System Verification**.
 - iii. Select the resource to be tested and press **F7=Commit**.
 - iv. Record any results provided and go to *"Service request numbers (SRNs)"* on page 109 to identify the failure and perform the action(s).
 - v. When testing is complete, press **F3** to return to the Diagnostic Selection menu. If you want to run another test, press **F3** again to return to the Function Selection menu.
 - Task selection
 - i. From the Function Selection menu, select **Task Selection** and press Enter.
 - ii. Select the task to be run and press **Enter**.
 - iii. If the Resource Selection List menu is displayed, select the resource on which the task is to be run and press **F7=Commit**.
 - iv. Follow the instruction for the selected task.
 - v. When the task is complete, press **F3** to return to the Task Selection List menu. If you want to run another test, press **F3** again to return to the Function Selection menu.
3. When testing is complete, press **F3** until the Diagnostic Operating Instructions screen is displayed; then press **F3** again to exit the diagnostic program.

2.9 Boot problem resolution

Depending on the boot device, a checkpoint might be displayed in the list of checkpoints in the management module for an extended period of time while the boot image is retrieved from the device.

This situation is particularly true for CD and network boot attempts. When booting from a CD, watch for a blinking activity LED on the CD or DVD drive. A blinking activity LED indicates that the loading of either the boot image, or additional information required by the operating system being booted, is still in progress. If the checkpoint is displayed for an extended period of time and the CD-drive or DVD-drive activity LED is not blinking, there might be a problem loading the boot image from the device.

Note For network boot attempts, if the system is not connected to an active network, or if there is no server configured to respond to the system's boot request, the system will still attempt to boot. Because time-out durations are necessarily long to accommodate retries, the system might appear to be hung.

If you suspect a problem loading the boot image, complete the following steps.

1. Make sure that your boot list is correct.
 - a. From the management-module Web interface, display the boot sequences for the blade servers in your Bull Blade Chassis - Enterprise: **Blade Tasks** → **Configuration** → **Boot Sequence**.
 - b. Find your blade server on the list that is displayed and make sure that the device from which you are attempting to boot is the first device in the boot sequence. If it is not, select your blade server from the list of servers and modify the boot sequence. Cycle power on your blade server to retry the boot.

Note If **Network** is selected, the blade server will try to boot from both Ethernet ports on the system board.

- c. If this boot attempt fails, do the following:
 - i. If you are attempting to boot from the network, go to Step 002.
 - ii. If you are attempting to boot from the CD or DVD drive, go to Step 003.
 - iii. If you are attempting to boot from a hard disk drive, go to Step 004.
 2. If you are attempting to boot from the network:
 - a. Make sure that the network cabling to the Bull Blade Chassis – Enterprise network switch is correct.
 - b. Check with the network administrator to make sure that the network is up.
 - c. Verify that the blade server for your system is running and configured to respond to your system.
 - d. Turn the blade server power off; then, turn it on and retry the boot operation.
 - e. If the boot still fails, replace the system-board and chassis assembly.

3. If you are attempting to boot from the CD or DVD drive:
 - a. From the management-module Web interface, make sure that the media tray is assigned to your blade server: **Blade Tasks** → **Remote Control**.
 - b. Turn the blade server power off; then, turn it on and retry the boot operation.
 - c. If the boot fails, try a known-good bootable CD.
 - d. If possible, try to boot another blade server in the Bull Blade Chassis - Enterprise to verify that the CD or DVD drive is functional.
 - If the CD boots on the second server, replace the system-board and chassis assembly in the Escala BL460 blade server you were originally trying to boot.
 - If the CD fails on the second server, replace the CD or DVD drive in the media tray.
 - e. If replacing the CD or DVD drive does not resolve the problem, replace the media tray.
 - f. If booting on all servers fails using the new media tray, replace the following in the Bull Blade Chassis - Enterprise:
 - Management module
 - Midplane

4. If you are attempting to boot from a hard disk drive.
 - a. Verify that the hard disk drive is installed.
 - b. Select the CD or DVD drive as the boot device.
 - c. Go to *"Performing the checkout procedure"* on page 149.
 - d. Reload the operating system onto the hard disk drive if the boot attempts from that disk continue to fail.
 - e. Replace the suspect hard disk drive if you are not able to load the operating system.
 - f. Replace the system-board and chassis assembly; then, retry loading the operating system.

2.10 Troubleshooting tables

Use the troubleshooting tables to find solutions to problems that have identifiable symptoms.

If these symptoms relate to shared Bull Blade Chassis - Enterprise resources, see *"Solving shared Bull Blade Chassis – Enterprise resource problems"* on page 188. If you cannot find the problem in these tables, see *"Running the diagnostics program"* on page 152 for information about testing the blade server.

If you have just added new software or a new optional device and the blade server is not working, complete the following steps before using the troubleshooting tables:

1. Remove the software or device that you just added.
2. Run the diagnostic tests to determine whether the blade server is running correctly.
3. Reinstall the new software or new device.

2.10.1 General problems

Identify general problem symptoms and corrective actions.

- Follow the suggested actions in the order in which they are listed in the Action column until the problem is solved.
- See Chapter 3, "Parts listing," on page 197 to determine which components are CRUs and which components are FRUs.
- If an action step is preceded by "(Trained service technician only)," that step must be performed only by a trained service technician.

Symptom	Action
A cover lock is broken, an LED is not working, or a similar problem has occurred.	If the part is a CRU, replace it. If the part is a FRU, the part must be replaced by a trained service technician.

2.10.2 Drive problems

Identify hard disk drive or solid-state drive (SSD) problem symptoms and what corrective actions to take.

- Follow the suggested actions in the order in which they are listed in the Action column until the problem is solved.
- See Chapter 3, "Parts listing," on page 197 to determine which components are CRUs and which components are FRUs.
- If an action step is preceded by "(Trained service technician only)," that step must be performed only by a trained service technician.

Symptom	Action
Not all drives are recognized by the hard disk drive firmware or operating system.	<ol style="list-style-type: none"> 1. Remove the first drive not recognized; then, run the hard disk drive diagnostic test again. 2. If the remaining drives are recognized, replace the drive that you removed with a new one.
System stops responding during drive operating system commands to test or look for bad blocks.	<ol style="list-style-type: none"> 1. Remove the drive that was being tested when the blade server stopped responding; then, run the diagnostic test again. 2. If the hard disk drive diagnostic test runs successfully, replace the drive you removed with a new one.

2.10.3 Intermittent problems

Identify intermittent problem symptoms and corrective actions.

<ul style="list-style-type: none"> Follow the suggested actions in the order in which they are listed in the Action column until the problem is solved. See <i>Chapter 3, "Parts listing,"</i> on page 197 to determine which components are CRUs and which components are FRUs. If an action step is preceded by "(Trained service technician only)," that step must be performed only by a trained service technician. 	
Symptom	Action
A problem occurs only occasionally and is difficult to diagnose.	<ol style="list-style-type: none"> Make sure that: <ul style="list-style-type: none"> When the blade server is turned on, air is flowing from the rear of the blade server at the blower grill. If there is no airflow, the blower is not working. This causes the blade server to overheat and shut down. Ensure that the self configuring SCSI device (SCSD) bus and devices are configured correctly. Check the management-module event log for errors

2.10.4 Keyboard problems

Identify keyboard problem symptoms and what corrective actions to take.

<ul style="list-style-type: none"> Follow the suggested actions in the order in which they are listed in the Action column until the problem is solved. See <i>Chapter 3, "Parts listing,"</i> on page 197 to determine which components are CRUs and which components are FRUs. If an action step is preceded by "(Trained service technician only)," that step must be performed only by a trained service technician. 	
Symptom	Action
All or some keys on the keyboard do not work.	<ol style="list-style-type: none"> Make sure that: <ul style="list-style-type: none"> The keyboard/video select button LED on the front of the blade server is lit, indicating that the blade server has ownership of the keyboard and video. The keyboard cable is securely connected to the management module. If you are using a PS/2 keyboard, the keyboard cable is connected to the proper connector. The blade server is using a supported Linux operating system that has loaded completely and supports USB devices. The blade server and the monitor are turned on. Replace the keyboard. Replace the management module on the Bull Blade Chassis - Enterprise. See the <i>Hardware Maintenance Manual and Troubleshooting Guide</i> or <i>Problem Determination and Service Guide</i> for your Bull Blade Chassis - Enterprise.

2.10.5 Management module service processor problems

Determine if a problem is a management module service processor problem and, if so, the corrective action to take.

<ul style="list-style-type: none"> • Follow the suggested actions in the order in which they are listed in the Action column until the problem is solved. • See <i>Chapter 3, "Parts listing,"</i> on page 197 to determine which components are CRUs and which components are FRUs. • If an action step is preceded by "(Trained service technician only)," that step must be performed only by a trained service technician. 	
Symptom	Action
Service processor in the management module reports a general monitor failure.	<p>Disconnect the Bull Blade Chassis - Enterprise from all electrical sources, wait for 30 seconds, reconnect it to the electrical sources, and restart the blade server.</p> <p>If the problem remains, see "<i>Solving undetermined problems</i>" on page 194. Also view the <i>Hardware Maintenance Manual and Troubleshooting Guide</i> or <i>Problem Determination and Service Guide</i> for your Bull Blade Chassis - Enterprise.</p>

2.10.6 Memory problems

Identify memory problem symptoms and what corrective actions to take.

<ul style="list-style-type: none"> Follow the suggested actions in the order in which they are listed in the Action column until the problem is solved. See <i>Chapter 3, "Parts listing,"</i> on page 197 to determine which components are CRUs and which components are FRUs. If an action step is preceded by "(Trained service technician only)," that step must be performed only by a trained service technician. 	
Symptom	Action
The amount of system memory displayed is less than the amount of physical memory installed.	<ol style="list-style-type: none"> Make sure that: <ul style="list-style-type: none"> All installed memory is recognized in the Display Vital Product Data of <code>lscfg -vp</code>. The memory modules are seated properly. You have installed the correct type of memory. If you changed the memory, you updated the memory configuration with the Configuration/Setup Utility program. All banks of memory on the DIMMs are enabled. The blade server might have automatically disabled a DIMM bank when it detected a problem or a DIMM bank could have been manually disabled. Check the management-module event log for error message (checkpoint or firmware error codes). <ul style="list-style-type: none"> If the DIMM was disabled by a system-management interrupt (SMI), replace the DIMM. If the DIMM was disabled by POST, obtain the eight-digit error code and replace the failing DIMM. Reseat the DIMM. Replace the DIMM. Replace the system-board and chassis assembly.

2.10.7 Microprocessor problems

Identify microprocessor problem symptoms and what corrective actions to take.

<ul style="list-style-type: none"> Follow the suggested actions in the order in which they are listed in the Action column until the problem is solved. See <i>Chapter 3, "Parts listing,"</i> on page 197 to determine which components are CRUs and which components are FRUs. If an action step is preceded by "(Trained service technician only)," that step must be performed only by a trained service technician. 	
Symptom	Action
The blade server will not boot or a checkpoint or firmware error code is logged in the management-module event log (the startup microprocessor is not working correctly)	<ol style="list-style-type: none"> If a checkpoint or firmware error was logged in the management module event log, correct that error. If no error was logged, restart the blade server and check the management module event log again for error codes. Replace the system-board and chassis assembly.

2.10.8 Monitor or video problems

View monitor or video problem symptoms to find corrective actions.

Some monitors have their own self-tests. If you suspect a problem with your monitor, see the documentation that comes with the monitor for instructions for testing and adjusting the monitor. If you cannot diagnose the problem, call for service.

<ul style="list-style-type: none"> Follow the suggested actions in the order in which they are listed in the Action column until the problem is solved. See <i>Chapter 3, "Parts listing,"</i> on page 197 to determine which components are CRUs and which components are FRUs. If an action step is preceded by "(Trained service technician only)," that step must be performed only by a trained service technician. 	
Symptom	Action
The screen is blank.	<ol style="list-style-type: none"> Make sure that: <ul style="list-style-type: none"> The keyboard/video select button LED on the front of the blade server is lit, indicating that the blade server has ownership of the keyboard and video. The monitor cables are connected properly. The monitor is turned on and the Brightness and Contrast controls are adjusted correctly. The blade server is using a supported operating system that has loaded completely. If you have verified these items and the screen remains blank, replace: <ol style="list-style-type: none"> Monitor Management module on the Bull Blade Chassis - Enterprise. See the <i>Hardware Maintenance Manual and Troubleshooting Guide</i> or <i>Problem Determination and Service Guide</i> for your Bull Blade Chassis - Enterprise.
Only the cursor appears.	<p>Make sure that the keyboard/video ownership on the Bull Blade Chassis - Enterprise has not been switched to another blade server.</p> <p>If the problem remains, see "<i>Solving undetermined problems</i>" on page 194.</p>
The monitor goes blank when you direct it to a working blade server, or goes blank when you start some application programs in the blade servers.	<p>Make sure that the monitor cable is connected to the video port on the Blade management module. Some monitors have their own self-tests. If you suspect a problem with the monitor, see the information that comes with the monitor for adjusting and testing instructions.</p> <p>If you still cannot find the problem, try using the monitor with another blade server. If the problem remains, see the <i>Hardware Maintenance Manual and Troubleshooting Guide</i> or <i>Problem Determination and Service Guide</i> for your Bull Blade Chassis - Enterprise.</p>
The screen is wavy, unreadable, rolling, distorted, or has screen jitter.	<ol style="list-style-type: none"> If the monitor self-tests show the monitor is working properly, consider the location of the monitor. Magnetic fields around other devices (such as transformers, appliances, fluorescent lights, and other monitors) can cause screen jitter or wavy, unreadable, rolling, or distorted screen images. If this happens, turn off the monitor. (Moving a color monitor while it is turned on might cause screen discoloration.) Then move the device and the monitor at least 305 mm (12 in.) apart. Turn on the monitor. <p>Notes:</p> <ol style="list-style-type: none"> To prevent diskette drive read/write errors, be sure the distance between monitors and diskette drives is at least 76 mm (3 in). Some monitor cables might cause unpredictable problems. Replace the monitor. Replace the management card. Replace the system-board and chassis assembly.

<ul style="list-style-type: none"> Follow the suggested actions in the order in which they are listed in the Action column until the problem is solved. See <i>Chapter 3, "Parts listing,"</i> on page 197 to determine which components are CRUs and which components are FRUs. If an action step is preceded by "(Trained service technician only)," that step must be performed only by a trained service technician. 	
Symptom	Action
Wrong characters appear on the screen.	<ol style="list-style-type: none"> If the wrong language is displayed, update the firmware or operating system with the correct language in the blade server that has ownership of the monitor. Replace the monitor. Replace the management card. Replace the system-board and chassis assembly.
No video.	<ol style="list-style-type: none"> Make sure that the correct blade server is selected, if applicable. Make sure that all cables are fastened securely.
After installing AIX using the local keyboard and video, the AIX console does not display.	<p>Run the change console command and reboot the blade server to switch the AIX console to a SOL connection. (This does not affect the console that is used by partition firmware.)</p> <ol style="list-style-type: none"> <code>chcons /dev/vty0</code> <code>shutdown -Fr</code>

2.10.9 Network connection problems

Identify network connection problem symptoms and what corrective actions to take.

<ul style="list-style-type: none"> Follow the suggested actions in the order in which they are listed in the Action column until the problem is solved. See <i>Chapter 3, "Parts listing,"</i> on page 197 to determine which components are CRUs and which components are FRUs. If an action step is preceded by "(Trained service technician only)," that step must be performed only by a trained service technician. 	
Symptom	Action
One or more blade servers are unable to communicate with the network.	<ol style="list-style-type: none"> Make sure that: <ul style="list-style-type: none"> The I/O modules for the network interface being used are installed in the correct Blade bays and are configured and operating correctly. See the <i>Hardware Maintenance Manual and Troubleshooting Guide</i> or <i>Problem Determination and Service Guide</i> for your Bull Blade Chassis - Enterprise for details. The settings in the I/O module are appropriate for the blade server (settings in the I/O module are blade-specific). If the problem remains, see "<i>Solving undetermined problems</i>" on page 194.

2.10.10 PCI expansion card (PIOCARD) problem isolation procedure

The hardware that controls PCI adapters and PCI card slots detected an error. The direct select address (DSA) portion of the system reference code (SRC) identifies the location code of the failing component.

The following table shows the syntax of a nine-word B700xxxx SRC as it might be displayed in the event log of the management module.

The first word of the SRC in this example is the message identifier, **B7001111**. This example numbers each word after the first word to show relative word positions.

The seventh word is the direct select address, which is **77777777** in the example.

Table 2-28. Nine-word system reference code in the management-module event log

Index	Sev	Source	Date/Time	Text
1	E	Blade_05	01/21/2008, 17:15:14	(ESCALA BL460 -BC1BLD5E) SYS F/W: Error. Replace UNKNOWN (5008FECF B7001111 22222222 33333333 44444444 55555555 66666666 77777777 88888888 99999999)

Depending on your operating system and the utilities you have installed, error messages might also be stored in an operating system log. See the documentation that comes with the operating system for more information.

Table 2-29 shows the procedure for isolating which PCI expansion card is failing.

Table 2-29. PCI expansion card problem isolation procedure

<ul style="list-style-type: none"> Follow the suggested actions in the order in which they are listed in the Action column until the problem is solved. See Chapter 3, "Parts listing," on page 197 to determine which components are CRUs and which components are FRUs. If an action step is preceded by "(Trained service technician only)," that step must be performed only by a trained service technician. 	
Symptom	Action
A B700xxxx error message indicates a problem with a PCI expansion card.	<ol style="list-style-type: none"> Collect the error log information. Get the DSA, which is word 7 of the associated B700xxxx SRC. Use the hexadecimal value of the DSA to determine the location code of the failing CRU. <ul style="list-style-type: none"> If the value is 05120010, the location code is P1-C11. If the value is xxxx 0100, the location code is P1-C12.

2.10.11 Optional device problems

Identify optional device problem symptoms and what corrective actions to take.

<ul style="list-style-type: none"> Follow the suggested actions in the order in which they are listed in the Action column until the problem is solved. See <i>Chapter 3, "Parts listing,"</i> on page 197 to determine which components are CRUs and which components are FRUs. If an action step is preceded by "(Trained service technician only)," that step must be performed only by a trained service technician. 	
Symptom	Action
An optional device that was just installed does not work.	<ol style="list-style-type: none"> Make sure that: <ul style="list-style-type: none"> The option is designed for the blade server. Contact your Bull support representative. You followed the installation instructions that came with the option. The option is installed correctly. You have not loosened any other installed devices or cables. If the option comes with its own test instructions, use those instructions to test the option. Reseat the device that you just installed. Replace the device that you just installed.

2.10.12 Power problems

Identify power problem symptoms and what corrective actions to take.

<ul style="list-style-type: none"> Follow the suggested actions in the order in which they are listed in the Action column until the problem is solved. See <i>Chapter 3, "Parts listing,"</i> on page 197 to determine which components are CRUs and which components are FRUs. If an action step is preceded by "(Trained service technician only)," that step must be performed only by a trained service technician. 	
Symptom	Action
Power switch does not work and reset button, if supported, does work.	<ol style="list-style-type: none"> Use the management module to verify that local power control for the blade server is enabled. Reseat the control-panel connector. Replace the bezel assembly. Replace the system-board and chassis assembly.

- Follow the suggested actions in the order in which they are listed in the Action column until the problem is solved.
- See *Chapter 3, "Parts listing,"* on page 197 to determine which components are CRUs and which components are FRUs.
- If an action step is preceded by "(Trained service technician only)," that step must be performed only by a trained service technician.

Symptom	Action
The blade server does not turn on.	<ol style="list-style-type: none"> 1. Make sure that: <ol style="list-style-type: none"> a. The power LED on the front of the Bull Blade Chassis - Enterprise is on. b. The LEDs on all the Chassis power modules are on. c. The blade server is in a blade bay that is supported by the power modules installed in the Bull Blade Chassis - Enterprise. d. The power-on LED on the blade server control panel is blinking slowly. <ul style="list-style-type: none"> • If the power LED is flashing rapidly instead of blinking slowly, and continues to flash rapidly, the blade server is not communicating with the management module; reseal the blade server by following these procedures: <ol style="list-style-type: none"> i. <i>"Removing the management card"</i>, on page 216 ii. <i>"Installing the management card"</i>, on page 217 If reseating the blade server or the management card does not resolve the problem, go to step 3. • If the power LED is off instead of flashing slowly, the blade bay is not receiving power, the blade server is defective, or the LED information panel is loose or defective. e. Local power control for the blade server is enabled (use the management module Web interface to verify), or the blade server was instructed through the management module Web interface to start. 2. If you just installed a device in the blade server, remove it, and restart the blade server. If the blade server now starts, you might have installed more devices than the power to that blade bay supports. 3. Try another blade server in the blade bay; if it works, replace the faulty blade server. 4. See <i>"Solving undetermined problems"</i> on page 194.
The blade server turns off for no apparent reason	<ol style="list-style-type: none"> 1. Make sure that each blade bay has a blade server, expansion unit, or blade filler correctly installed. If these components are missing or incorrectly installed, an over-temperature condition might result in shutdown. 2. If a microprocessor error LED is lit, replace the system-board and chassis assembly.
The blade server does not turn off.	<ol style="list-style-type: none"> 1. Verify whether you are using an ACPI or non-ACPI operating system. If you are using a non-ACPI operating system: <ol style="list-style-type: none"> a. Press Ctrl+Alt+Delete. b. Turn off the system by holding the power-control button for 4 seconds. c. If the blade server fails during POST and the power-control button does not work, remove the blade server from the bay and reseal it. 2. If the problem remains or if you are using an ACPI-aware operating system, suspect the system-board and chassis assembly.

2.10.13 POWER Hypervisor (PHYP) problems

The POWER Hypervisor (PHYP) provides error diagnostics with associated error codes and fault isolation procedures for troubleshooting.

When the POWER6™ Hypervisor error analysis determines a specific fault, the hypervisor logs an error code that identifies a failing component. When the analysis is not definitive, the hypervisor logs one or more isolation procedures for you to run to identify and correct the problem.

Table 2-30 describes the isolation procedures.

Table 2-30. POWER Hypervisor isolation procedures

<ul style="list-style-type: none"> Follow the suggested actions in the order in which they are listed in the Action column until the problem is solved. See Chapter 3, "Parts listing," on page 197 to determine which components are CRUs and which components are FRUs. If an action step is preceded by "(Trained service technician only)," that step must be performed only by a trained service technician. 		
Isolation Procedure Code	Symptom	Action
LPARCFG Symbolic CRU	There is a configuration problem with the system or a logical partition.	<ol style="list-style-type: none"> Perform the procedure associated with the SRC code that is called out after the LPARCFG call. Check processor and memory allocations of the system or the partitions. Verify that there are enough functioning processor and memory resources in the system for all of the partitions. Processor or memory resources that failed or were Garded during system IPL could cause the IPL problem in the partition. Check the bus and I/O adapter allocations for the partition. Verify that the partition has load source and console I/O resources. Check the IPL mode of the system or failing partition. For further assistance, contact Bull Support.

<ul style="list-style-type: none"> Follow the suggested actions in the order in which they are listed in the Action column until the problem is solved. See <i>Chapter 3, "Parts listing,"</i> on page 197 to determine which components are CRUs and which components are FRUs. If an action step is preceded by "(Trained service technician only)," that step must be performed only by a trained service technician. 		
Isolation Procedure Code	Symptom	Action
MEMDIMM Symbolic CRU	The failing component is one of the memory DIMMs.	<ol style="list-style-type: none"> Replace the failing CRU: <ul style="list-style-type: none"> DIMM 1 (Px-C1) P1-C1 is memory module 1 DIMM 2 (Px-C2) Memory module 2 DIMM 3 (Px-C3) Memory module 3 DIMM 4 (Px-C4) Memory module 4 DIMM 5 (Px-C5) Memory module 5 DIMM 6 (Px-C6) Memory module 6 DIMM 7 (Px-C7) Memory module 7 DIMM 8 (Px-C8) Memory module 8 See "<i>Removing a memory module</i>" on page 213 for location information and the removal procedure. Install new memory DIMMs, as described in "<i>Installing a memory module</i>" on page 214. <p>See "<i>Supported DIMMs</i>" on page 5 for more information.</p>
NEXTLVL Symbolic CRU	Contact Bull Support.	
PIOCARD Symbolic CRU	The hardware that controls PCI adapters and PCI card slots detected an error. The direct select address (DSA) portion of the system reference code (SRC) identifies the location code of the failing component.	<ol style="list-style-type: none"> Collect the error log information. Get the DSA, which is word 7 of the associated B700xxxx SRC. Use the hexadecimal value of the DSA to determine the location code of the failing CRU. <ul style="list-style-type: none"> If the value is 05120010, the location code is P1-C11. If the value is xxxx 0100, the location code is P1-C12.

2.10.14 Service processor problems

The baseboard management controller (BMC) is a flexible service processor that provides error diagnostics with associated error codes, and fault isolation procedures for troubleshooting.

Note Resetting the service processor causes a POWER6 reset/reload, which generates a dump. The dump is recorded in the management module event log. The reset/reload dump occurs whenever the service processor resets, such as when resetting the service processor through the management module Web interface or through the management module command line interface.

When the advanced POWER6 service processor error analysis determines a specific fault, the service processor logs an error code to identify the failing component.

When the analysis is not definitive, the service processor logs one or more isolation procedures for you to run to identify and correct the problem.

The service processor reports fault isolation procedure codes to identify a specific service action. The isolation procedure code is recorded in the management-module event log.

A message with three procedures might be similar to the following example, except that the entry would be on one line in the event log:

```
(SN#YL31W7120029) SYS F/W: CEC Hardware VPD.  
See procedure FSPSP07, FSPSP28 then FSPO200  
(5000004C B15A3303 22222222 33333333 44444444 55555555 66666666  
77777777 88888888 99999999)
```

B15A3303 is the identifier word of the associated SRC. The rest of the nine words in the SRC are shown in sequence.

A message that identifies customer replaceable units (CRUs) might be similar to the following example:

```
(SN#YL31W7120029) SYS F/W: Error. Replace PIOCARD then Sys Brd  
(500213A0 B7006973 22222222 33333333 44444444 55555555 66666666  
77777777 88888888 99999999)
```

A message with multiple replacement callouts might be too long to display. In such a case, the message removes SRC words starting with word 2 and inserts an X for every removed word. The following example shows an error log entry that did not have enough room for words 2 and 3:

```
(SN#YL31W7120029) SYS F/W: CEC Hardware VPD.  
See procedure FSPSP07, FSPSP28 then FSPO200  
(50000014 B15A3303 XX 44444444 55555555 66666666 77777777  
8888888888 99999999)
```

<ul style="list-style-type: none"> Follow the suggested actions in the order in which they are listed in the Action column until the problem is solved. See <i>Chapter 3, "Parts listing,"</i> on page 197 to determine which components are CRUs and which components are FRUs. If an action step is preceded by "(Trained service technician only)," that step must be performed only by a trained service technician. 		
Isolation Procedure Code	Symptom	Action
ANYPROC Symbolic CRU	The failing component is one of the system processors.	Replace the system board and chassis assembly, as described in <i>"Replacing the Tier 2 system-board and chassis assembly"</i> on page 229.
BCPROB Symbolic CRU	Error code 1xxx2670 indicates that the Blade encountered a problem, and the blade server was automatically shut down as a result.	<ol style="list-style-type: none"> 1. Check the management-module event log for entries that were made around the time that the Escala BL460 blade server shut down. 2. Resolve any problems. 3. Remove the blade from the Bull Blade Chassis - Enterprise and then reinsert the blade server. 4. Power on the blade server. 5. Monitor the blade server operation to verify that the problem is solved. 6. If the Chassis is functioning normally, but the 1xxx2670 problem persists, Replace the system board and chassis assembly, as described in <i>"Replacing the Tier 2 system-board and chassis assembly"</i> on page 229.
CAPACTY Symbolic CRU	The failing component is the management card.	<ol style="list-style-type: none"> 1. Replace the management card, as described in <i>"Removing the management card"</i> on page 216 and <i>"Installing the management card"</i> on page 217. 2. After replacing the card and installing the blade server in the chassis unit and before rebooting the blade server or performing other operations, ensure that the initialization of the management card VPD occurs by waiting for the management module to discover the blade server. Otherwise, the system might fail to IPL.
CLCKMOD Symbolic CRU	The logic oscillator is failing.	Replace the system board and chassis assembly, as described in <i>"Replacing the Tier 2 system-board and chassis assembly"</i> on page 229.
DTRCARD Symbolic CRU	Error code 1xxx2625, 2626, or 2527 indicates that the blade server is reporting a problem with the PCIe expansion card.	<ol style="list-style-type: none"> 1. Reseat the PCIe expansion card. 2. If the problem persists, replace the expansion card. 3. If the problem persists, go to <i>"Checkout procedure"</i>, on page 148. 4. If the problem persists, Replace the system board and chassis assembly, as described in <i>"Replacing the Tier 2 system-board and chassis assembly"</i> on page 229.

<ul style="list-style-type: none"> Follow the suggested actions in the order in which they are listed in the Action column until the problem is solved. See <i>Chapter 3, "Parts listing,"</i> on page 197 to determine which components are CRUs and which components are FRUs. If an action step is preceded by "(Trained service technician only)," that step must be performed only by a trained service technician. 		
Isolation Procedure Code	Symptom	Action
FSPSP01	A part vital to system function has been deconfigured. Review the system error logs for errors that call out CRUs that are relevant to each reason code.	<p>If replacing parts does not resolve the error, perform one of the following procedures, based on the SRC code that is called out after the FSPSP01 call.</p> <p>If the SRC is B1xxB10C or B1xxB10D The system has detected a deconfigured memory controller that is required for the system to function, or it has detected that there is not enough memory or that the memory is plugged incorrectly.</p> <ol style="list-style-type: none"> Reseat all of the memory DIMMs in the system enclosure but do not replace any memory DIMMs at this time. Reseat the memory DIMMs as described in <i>"Installing a memory module"</i> on page 214 If the problem persists, replace each memory DIMM, by following the action for symbolic FRU MEMDIMM. Install the blade server into the Bull Blade Chassis - Enterprise after each DIMM replacement and restart the blade to verify if the problem is solved. If the problem persists after replacing all DIMMs, Replace the system board and chassis assembly, as described in <i>"Replacing the Tier 2 system-board and chassis assembly"</i> on page 229. <p>If the SRC is B1xxB107 or B1xxB108 The system has detected a problem with a clock card.</p> <ol style="list-style-type: none"> Replace the system board and chassis assembly, as described in <i>"Replacing the Tier 2 system-board and chassis assembly"</i> on page 229. <p>If the SRC is B1xxB106 The system has detected that the planars are deconfigured.</p> <ol style="list-style-type: none"> Replace the system board and chassis assembly, as described in <i>"Replacing the Tier 2 system-board and chassis assembly"</i> on page 229. <p>If the SRC is B1xxB110 or B1xxB111 The system has detected that all of the I/O bridges are deconfigured.</p> <ol style="list-style-type: none"> Replace the system board and chassis assembly, as described in <i>"Replacing the Tier 2 system-board and chassis assembly"</i> on page 229.
FSPSP02	This procedure is for boot failures that terminate very early in the boot process or when the management card or the VPD data on the management card is not operational or is not present.	<ol style="list-style-type: none"> Replace the management card, as described in <i>"Removing the management card"</i> on page 216 and <i>"Installing the management card"</i> on page 217. After replacing the card and installing the blade server in the chassis unit and before rebooting the blade server or performing other operations, ensure that the initialization of the management card VPD occurs by waiting for the management module to discover the blade server. Otherwise, the system might fail to IPL. If the problem persists, Replace the system board and chassis assembly, as described in <i>"Replacing the Tier 2 system-board and chassis assembly"</i> on page 229.
FSPSP03	A system operator or user error has occurred.	Refer to the documentation for the function you were attempting to perform.

<ul style="list-style-type: none"> Follow the suggested actions in the order in which they are listed in the Action column until the problem is solved. See <i>Chapter 3, "Parts listing,"</i> on page 197 to determine which components are CRUs and which components are FRUs. If an action step is preceded by "(Trained service technician only)," that step must be performed only by a trained service technician. 		
Isolation Procedure Code	Symptom	Action
FSPSP04	A problem has been detected in the service processor firmware.	<ol style="list-style-type: none"> Verify that the operating system is running. If it is running, perform an in-band firmware update, as described in <i>"Updating the firmware"</i> on page 231. If the problem persists, Replace the system board and chassis assembly, as described in <i>"Replacing the Tier 2 system-board and chassis assembly"</i> on page 229.
FSPSP05	The service processor has detected a problem in the platform firmware.	<ol style="list-style-type: none"> Verify that the operating system is running. If it is running, perform an in-band firmware update, as described in <i>"Updating the firmware"</i> on page 231. If the problem persists, Replace the system board and chassis assembly, as described in <i>"Replacing the Tier 2 system-board and chassis assembly"</i> on page 229.
FSPSP06	The service processor reported a suspected intermittent problem.	Contact Bull Support.
FSPSP07	The time of day has been reset to the default value.	<ol style="list-style-type: none"> Use the chdate command to set the VIOS date and time, using one of the following syntaxes: chdate [-year YYyy] [-month mm] [-day dd] [-hour HH] [-minute MM] [-timezone TZ] chdate mmddHHMM[YYyy yy] [-timezone TZ] If the problem persists, replace the battery, as described in <i>"Removing the battery"</i> on page 224 and <i>"Installing the battery"</i> on page 225.

<ul style="list-style-type: none"> Follow the suggested actions in the order in which they are listed in the Action column until the problem is solved. See <i>Chapter 3, "Parts listing,"</i> on page 197 to determine which components are CRUs and which components are FRUs. If an action step is preceded by "(Trained service technician only)," that step must be performed only by a trained service technician. 		
Isolation Procedure Code	Symptom	Action
FSPSP09	A problem has been detected with a memory DIMM, but it cannot be isolated to a specific memory DIMM.	<p>Replace the CRU called out after this FSPSP call. If the CRU that is called out is a DIMM CRU, perform the following procedure:</p> <ol style="list-style-type: none"> Replace both memory DIMMs of the pair on the microprocessor that contains the failing CRU: <ul style="list-style-type: none"> DIMM 1 (Px-C1) For P1-C1, replace DIMMS 1 and 3. DIMM 2 (Px-C2) Replace DIMMS 2 and 4. DIMM 3 (Px-C3) Replace DIMMS 1 and 3. DIMM 4 (Px-C4) Replace DIMMS 2 and 4. DIMM 5 (Px-C5) Replace DIMMS 5 and 7. DIMM 6 (Px-C6) Replace DIMMS 6 and 8. DIMM 7 (Px-C7) Replace DIMMS 5 and 7. DIMM 8 (Px-C8) Replace DIMMS 6 and 8. See "<i>Removing a memory module</i>" on page 213 for location information and the removal procedure. Install new memory DIMMs, as described in "<i>Installing a memory module</i>" on page 214. <p>See "<i>Supported DIMMs</i>" on page 5 for more information.</p>
FSPSP10	The part indicated in the CRU callout that follows this procedure is invalid or missing for this system's configuration.	<ol style="list-style-type: none"> If there is only one CRU called out after this FSPSP10 call: <ol style="list-style-type: none"> Verify that the CRU is installed, connected, and seated properly. If the CRU is seated properly and the problem persists, replace the CRU. If the CRU is missing, add the CRU. If multiple CRUs are called out, they have identical serial numbers. Remove all but one of the CRUs.
FSPSP11	The service processor has detected an error on the RIO/HSL port in the system unit.	<ol style="list-style-type: none"> Verify that the operating system is running. If it is running, perform an in-band firmware update, as described in "<i>Updating the firmware</i>" on page 231. If the problem persists, Replace the system board and chassis assembly, as described in "<i>Replacing the Tier 2 system-board and chassis assembly</i>" on page 229.
FSPSP12	The DIMM CRU that was called out failed to correct the memory error.	Replace the system board and chassis assembly, as described in " <i>Replacing the Tier 2 system-board and chassis assembly</i> " on page 229.

<ul style="list-style-type: none"> Follow the suggested actions in the order in which they are listed in the Action column until the problem is solved. See <i>Chapter 3, "Parts listing,"</i> on page 197 to determine which components are CRUs and which components are FRUs. If an action step is preceded by "(Trained service technician only)," that step must be performed only by a trained service technician. 		
Isolation Procedure Code	Symptom	Action
FSPSP14	The Service Processor cannot establish communication with the server firmware. The server firmware will continue to run the system and partitions while it attempts to recover the communications. Server firmware recovery actions will continue for approximately 30 to 40 minutes.	<ol style="list-style-type: none"> View the event log in the management module to locate the system reference code (SRC) and the time that the event was logged. See <i>"Error logs"</i> on page 147. If progress codes are being displayed, the server firmware was able to reset the service processor and solve the problem. Record the time the log was created or when you first noticed this SRC. If progress codes are not being displayed, examine the management module event log to see if an A7006995 SRC has been displayed. If an A7006995 SRC has been displayed, the blade server is powering off partitions and attempting a server dump. Follow the action in the A7006995 SRC description if the partitions do not terminate as requested. If an A7006995 SRC has not been displayed, has the A1xx SRC remained for more than 40 minutes? If so, the server firmware could not begin terminating the partitions. Contact your next level of support to assist in attempting to terminate any remaining partitions and forcing a server dump. Collect the dump for support and power off and power on the blade server. If an A1xx SRC has not remained more than 40 minutes, call Bull Support.
FSPSP16	Save any error log and dump data and contact your next level of support for assistance.	Contact Bull Support.
FSPSP17	A system uncorrectable error has occurred.	<ul style="list-style-type: none"> Look for other serviceable events. Use the SRCs that those events call out to determine and fix any problems.
FSPSP18	A problem has been detected in the platform licensed internal code (LIC).	<ol style="list-style-type: none"> Verify that the operating system is running. If it is running, perform an in-band firmware update, as described in <i>"Updating the firmware"</i> on page 231. If the problem persists, Replace the system board and chassis assembly, as described in <i>"Replacing the Tier 2 system-board and chassis assembly"</i> on page 229.
FSPSP20	A failing item has been detected by a hardware procedure.	Call Bull Support.
FSPSP22	The system has detected that a processor chip is missing from the system configuration because JTAG lines are not working.	Replace the system board and chassis assembly, as described in <i>"Replacing the Tier 2 system-board and chassis assembly"</i> on page 229.
FSPSP23	The system needs to perform a service processor dump.	<ol style="list-style-type: none"> Save the service processor dump to storage by using the partition dump pin control on the control panel. Once the dump is complete, attempt to re-IPL the system. Call Bull Support.

- Follow the suggested actions in the order in which they are listed in the Action column until the problem is solved.
- See *Chapter 3, "Parts listing,"* on page 197 to determine which components are CRUs and which components are FRUs.
- If an action step is preceded by "(Trained service technician only)," that step must be performed only by a trained service technician.

Isolation Procedure Code	Symptom	Action
FSPSP24	The system is running degraded. Array bit steering may be able to correct this problem without replacing hardware.	<ol style="list-style-type: none"> 1. Power off the blade server, as described in <i>"Turning off the blade server"</i> on page 11. 2. Remove the blade server from the Bull Blade Chassis - Enterprise and reinsert the blade server into the Bull Blade Chassis - Enterprise. 3. Power on the blade server, as described in <i>"Turning on the blade server"</i> on page 10. 4. If the problem persists, replace the CRU that is called out after this procedure.
FSPSP27	An attention line has been detected as having a problem.	Replace the CRU that is called out before this FSPSP27 call. If the CRU does not correct the problem, call Bull Support.
FSPSP28	The resource ID (RID) of the CRU could not be found in the Vital Product Data (VPD) table.	<ol style="list-style-type: none"> 1. Find another callout that reads □FSPxxxx□ where xxxx is a 4-digit hex number that represents the resource ID. Record the resource ID and the model of the system. 2. Call Bull Support to find out what CRU the resource ID represents. 3. Replace the CRU that the resource ID represents.
FSPSP29	The system has detected that all I/O bridges are missing from the system configuration.	Replace the system board and chassis assembly, as described in <i>"Replacing the Tier 2 system-board and chassis assembly"</i> on page 229.
FSPSP30	<p>A problem has been encountered accessing the management card or the VPD data found on the management card has been corrupted.</p> <p>This error occurred before VPD collection was completed, so no location codes have been created.</p>	<ol style="list-style-type: none"> 1. Replace the management card, as described in <i>"Removing the management card"</i> on page 216 and <i>"Installing the management card"</i> on page 217. 2. After replacing the card and installing the blade server in the chassis unit and before rebooting the blade server or performing other operations, ensure that the initialization of the management card VPD occurs by waiting for the management module to discover the blade server. Otherwise, the system might fail to IPL. 3. If the problem persists, Replace the system board and chassis assembly, as described in <i>"Replacing the Tier 2 system-board and chassis assembly"</i> on page 229.
FSPSP31	The service processor has detected that one or more of the required fields in the system VPD has not initialized.	<ol style="list-style-type: none"> 1. When the system reaches the SMS, set the system VPD values that are required, which automatically resets the service processor. 2. Power on the blade server, as described in <i>"Turning on the blade server"</i> on page 10.

- Follow the suggested actions in the order in which they are listed in the Action column until the problem is solved.
- See *Chapter 3, "Parts listing,"* on page 197 to determine which components are CRUs and which components are FRUs.
- If an action step is preceded by "(Trained service technician only)," that step must be performed only by a trained service technician.

Isolation Procedure Code	Symptom	Action
FSPSP32	<p>A problem with the enclosure has been found.</p> <p>The problem is one of the following problems:</p> <ul style="list-style-type: none"> √ The enclosure VPD cannot be found. √ The enclosure serial number is not programmed. √ The enclosure feature code is not programmed. 	<p>Record the reason code, which is the last four digits of the first word from the SRC.</p> <p>Perform one of the following procedures based upon the value of the reason code:</p> <ul style="list-style-type: none"> • Reason code A46F <ol style="list-style-type: none"> 1. Verify that the operating system is running. If it is running, perform an in-band firmware update. 2. If the problem persists, Replace the system board and chassis assembly, as described in <i>"Replacing the Tier 2 system-board and chassis assembly"</i> on page 229. 3. If the problem persists, call Bull Support. • Reason code A460 <ol style="list-style-type: none"> 1. Set the enclosure serial number using SMS, which automatically resets the service processor. 2. If the problem persists, call Bull Support. • Reason code A45F <ol style="list-style-type: none"> 1. Set the enclosure feature code using SMS, which automatically resets the service processor. 2. If the problem persists, call Bull Support. <p>If you do not see your reason code listed, call Bull Support.</p>

<ul style="list-style-type: none"> Follow the suggested actions in the order in which they are listed in the Action column until the problem is solved. See <i>Chapter 3, "Parts listing,"</i> on page 197 to determine which components are CRUs and which components are FRUs. If an action step is preceded by "(Trained service technician only)," that step must be performed only by a trained service technician. 		
Isolation Procedure Code	Symptom	Action
FSPSP34	The memory cards are plugged in an invalid configuration and cannot be used by the system.	<p>Install a DIMM for each of the dual processors on the ESCALA BL460 blade server. Install the first pair in DIMM connectors 2 and 4.</p> <p>Look for the following error codes in order. Follow the procedure for the first code you find.</p> <p>SRC B1xx C02A A memory card is missing from the system.</p> <p>The additional parts in the CRU callout list include all memory cards in the group with the missing card. To correct the error, visually check the system to determine which card is missing, and add the card.</p> <p>SRC B1xx C029 A memory card is a different type than the other memory cards in the same group.</p> <p>The additional parts in the CRU callout list include all memory cards in the group that contain the error. To correct the error, exchange the memory cards of the incorrect type with those of the correct type.</p> <p>SRC B1xx C02B A group of memory cards are missing and are required so that other memory cards on the board can be configured.</p> <p>The additional parts in the CRU callout list include all the missing memory cards in the group. To correct the error, add or move the memory cards to the correct locations.</p> <p>SRC B1xx C036 A memory card is not supported in this system.</p> <p>The additional parts in the CRU callout list include all memory cards in the group that contain the unsupported cards. To correct the error, remove the unsupported cards from the system or replace them with the correct type.</p>
FSPSP35	The system has detected a problem with a memory controller.	<p>Enable redundant utilization by performing the following procedure:</p> <ol style="list-style-type: none"> Power off the blade server, as described in <i>"Turning off the blade server"</i> on page 11. Remove the blade server from the Bull Blade Chassis - Enterprise and reinsert the blade server. Power on the blade server, as described in <i>"Turning on the blade server"</i> on page 10.
FSPSP38	The system has detected an error within the JTAG path.	Replace the CRU that is called out before this FSPSP38 call. If the CRU that you replace does not correct the problem, call Bull Support.
FSPSP42	An error communicating between two system processors was detected.	Contact Bull Support.
FSPSP45	The system has detected an error within the FSI path.	Replacing the system board and chassis assembly, as described in <i>"Replacing the Tier 2 system-board and chassis assembly"</i> on page 229.

<ul style="list-style-type: none"> Follow the suggested actions in the order in which they are listed in the Action column until the problem is solved. See <i>Chapter 3, "Parts listing,"</i> on page 197 to determine which components are CRUs and which components are FRUs. If an action step is preceded by "(Trained service technician only)," that step must be performed only by a trained service technician. 		
Isolation Procedure Code	Symptom	Action
FSPSP46	Some corrupt areas of flash or RAM have been detected on the Service Processor.	Replace the system board and chassis assembly, as described in <i>"Replacing the Tier 2 system-board and chassis assembly"</i> on page 229.
FSPSP47	The system has detected an error within the PSI link.	Replace the system board and chassis assembly, as described in <i>"Replacing the Tier 2 system-board and chassis assembly"</i> on page 229.
FSPSP48	A diagnostics function detects an external processor interface problem.	If the CRUs called out before this procedure do not fix the problem, Contact Bull Support.
FSPSP49	A diagnostic function detects an internal processor interface problem.	If the CRUs called out before this procedure do not fix the problem, Contact Bull Support.
FSPSP50	A diagnostic function detects a connection problem between a processor chip and a GX chip.	If the CRUs called out before this procedure do not fix the problem, Contact Bull Support.
FSPSP51	Runtime diagnostics has detected a memory bus correctable error that is exceeding threshold. The memory bus correctable error does not threaten the system operation at the moment. However, the system is operating under degraded mode.	<p>Replace the CRU called out after this FSPSP call. If the CRU that is called out is a DIMM CRU, perform the following procedure:</p> <ol style="list-style-type: none"> Replace both memory DIMMs of the pair on the microprocessor that contains the failing CRU: <ul style="list-style-type: none"> DIMM 1 (Px-C1) For P1-C1, replace DIMMS 1 and 3. DIMM 2 (Px-C2) Replace DIMMS 2 and 4. DIMM 3 (Px-C3) Replace DIMMS 1 and 3. DIMM 4 (Px-C4) Replace DIMMS 2 and 4. DIMM 5 (Px-C5) Replace DIMMS 5 and 7. DIMM 6 (Px-C6) Replace DIMMS 6 and 8. DIMM 7 (Px-C7) Replace DIMMS 5 and 7. DIMM 8 (Px-C8) Replace DIMMS 6 and 8. See <i>"Removing a memory module"</i> on page 213 for location information and the removal procedure. Install new memory DIMMs, as described in <i>"Installing a memory module"</i> on page 214. <p>See <i>"Supported DIMMs"</i> on page 5 for more information.</p>
FSPSP53	A network error has occurred between the Service Processor and the network switch.	Replace the system board and chassis assembly, as described in <i>"Replacing the Tier 2 system-board and chassis assembly"</i> on page 229.

- Follow the suggested actions in the order in which they are listed in the Action column until the problem is solved.
- See *Chapter 3, "Parts listing,"* on page 197 to determine which components are CRUs and which components are FRUs.
- If an action step is preceded by "(Trained service technician only)," that step must be performed only by a trained service technician.

Isolation Procedure Code	Symptom	Action
FSPSP54	A processor over-temperature has been detected. Check for any environmental issues before replacing any parts.	<ol style="list-style-type: none"> 1. Measure the ambient room temperature to see if it is in within the upper limit of the normal operating range. The upper limit is less than 35 degrees C or 95 degrees F. If the temperature exceeds this limit, you must bring down the room temperature until it is within the limit. When the temperature is within range, retry the operation. 2. If the temperature is within the acceptable range, check the front and rear of the Bull Blade Chassis - Enterprise to verify that the each is free of obstructions that would impede the airflow. If there are obstructions, you must clear the obstructions. Also clean the air inlets and exits in the Bull Blade Chassis - Enterprise drawer as required. If you cleared obstructions, retry the operation. 3. Verify that the fans in the Bull Blade Chassis - Enterprise are working correctly. If not, replace fans that are not turning or that are turning slowly. If you replace fans, wait for the unit to cool and retry the operation. 4. If the fans are functioning correctly, there are environmental issues with the cooling of the processors. Replace the system board and chassis assembly, as described in <i>"Replacing the Tier 2 system-board and chassis assembly"</i> on page 229
FSPSP55	An error has been detected on a bus between two FRUs. The end-point FRUs have been called out, however, the source of the error could be the bus path between the FRUs.	The bus error is corrected by the customer replaceable units (CRUs) called out after this procedure. Replace the CRUs called out after this procedure. See Chapter 4, <i>"Removing and replacing blade server components,"</i> on page 201 for more information.
IOHUB Symbolic CRU	The failing component is the RIO/HSL NIC on the IPL path.	Replace the system board and chassis assembly, as described in <i>"Replacing the Tier 2 system-board and chassis assembly"</i> on page 229.
IOBRDG Symbolic CRU	The failing component is the RIO/HSL I/O bridge on the IPL path.	Replace the system board and chassis assembly, as described in <i>"Replacing the Tier 2 system-board and chassis assembly"</i> on page 229.
MEMBRD Symbolic CRU	The failing component is the board the memory DIMMs plug into.	Replace the system board and chassis assembly, as described in <i>"Replacing the Tier 2 system-board and chassis assembly"</i> on page 229.
MEMCTLR Symbolic CRU	The failing component is one of the memory controllers.	Replace the system board and chassis assembly, as described in <i>"Replacing the Tier 2 system-board and chassis assembly"</i> on page 229.

- Follow the suggested actions in the order in which they are listed in the Action column until the problem is solved.
- See *Chapter 3, "Parts listing,"* on page 197 to determine which components are CRUs and which components are FRUs.
- If an action step is preceded by "(Trained service technician only)," that step must be performed only by a trained service technician.

Isolation Procedure Code	Symptom	Action
MEMDIMM Symbolic CRU	The failing component is one of the memory DIMMs.	1. Replace the failing CRU: DIMM 1 (Px-C1) P1-C1 is memory module 1 DIMM 2 (Px-C2) Memory module 2 DIMM 3 (Px-C3) Memory module 3 DIMM 4 (Px-C4) Memory module 4 DIMM 5 (Px-C5) Memory module 5 DIMM 6 (Px-C6) Memory module 6 DIMM 7 (Px-C7) Memory module 7 DIMM 8 (Px-C8) Memory module 8 2. See <i>"Removing a memory module"</i> on page 213 for location information and the removal procedure. 3. Install new memory DIMMs, as described in <i>"Installing a memory module"</i> on page 214. See <i>"Supported DIMMs"</i> on page 5 for more information.
NO12VDC Symbolic CRU	Error code 1xxx2647 indicates that the blade server is reporting that 12V dc is not present on the Bull Blade Chassis - Enterprise midplane.	1. Check the management-module event log for entries that indicate a power problem with the Bull Blade Chassis - Enterprise. 2. Resolve any problems. 3. Remove the blade from the Bull Blade Chassis - Enterprise and then reinsert the blade server. 4. Power on the blade server. 5. Monitor the blade server operation to verify that the problem is solved. 6. If the Chassis is functioning normally, but the 1xxx2647 problem persists, Replace the system board and chassis assembly, as described in <i>"Replacing the Tier 2 system-board and chassis assembly"</i> on page 229.
NODEPL Symbolic CRU	The failing component is the node midplane.	Replace the system board and chassis assembly, as described in <i>"Replacing the Tier 2 system-board and chassis assembly"</i> on page 229.
TOD_BAT Symbolic CRU	The battery for the time-of-day battery is low or failing.	Replace the battery, as described in <i>"Removing the battery"</i> on page 224 and <i>"Installing the battery"</i> on page 225.

2.10.15 Software problems

Use this information to recognize software problem symptoms and to take corrective actions.

<ul style="list-style-type: none"> Follow the suggested actions in the order in which they are listed in the Action column until the problem is solved. See <i>Chapter 3, "Parts listing,"</i> on page 197 to determine which components are CRUs and which components are FRUs. If an action step is preceded by "(Trained service technician only)," that step must be performed only by a trained service technician. 	
Symptom	Action
You suspect a software problem.	<ol style="list-style-type: none"> To determine whether the problem is caused by the software, make sure that: <ul style="list-style-type: none"> The server has the minimum memory that is needed to use the software. For memory requirements, see the information that comes with the software. <p>Note: If you have just installed an adapter or memory, the blade server might have a memory-address conflict.</p> <ul style="list-style-type: none"> The software is designed to operate on the blade server. Other software works on the blade server. The software works on another server. If you received any error messages when using the software, see the information that comes with the software for a description of the messages and suggested solutions to the problem. Contact your place of purchase of the software.

2.10.16 Universal Serial Bus (USB) port problems

This topic describes USB port problem symptoms and corrective actions.

<ul style="list-style-type: none"> Follow the suggested actions in the order in which they are listed in the Action column until the problem is solved. See <i>Chapter 3, "Parts listing,"</i> on page 197 to determine which components are CRUs and which components are FRUs. If an action step is preceded by "(Trained service technician only)," that step must be performed only by a trained service technician. 	
Symptom	Action
A USB device does not work.	<p>Make sure that:</p> <ul style="list-style-type: none"> The correct USB device driver is installed. The operating system supports USB devices.

2.11 Light path diagnostics

Light path diagnostics is a system of LEDs on the control panel and on the system board of the blade server. When an error occurs, LEDs are lit throughout the blade server. If the control panel indicates an error, use the descriptions of the LEDs to diagnose the problem and take corrective action.

LEDs are available for the following components:

- Battery
- SAS disk drive or solid state drive (SSD)
- Management card
- Memory modules (DIMMs)
- PCIe high speed expansion card option
- 1Xe CIOv expansion card option
- System board and chassis assembly

2.11.1 Viewing the light path diagnostic LEDs

After reading required Safety Attention, look at the control panel to determine if the LEDs indicate a sub-optimal condition or an error.

Before working inside the blade server to view light path diagnostic LEDs, read “Safety” on page vii and “Handling static-sensitive devices” on page 202.

If an error occurs, view the light path diagnostic LEDs in the following order:

1. Look at the control panel on the front of the blade server. See “Blade server control panel buttons and LEDs” on page 7.
 - If the information LED is lit, it indicates that information about a suboptimal condition in the blade server is available in the management-module event log.
 - If the blade-error LED is lit, it indicates that an error has occurred and you should proceed to the next step.
2. If an error has occurred, view the light path diagnostics panel and LEDs:
 - a. Remove the blade server from the Bull Blade Chassis - Enterprise.
 - b. Place the blade server on a flat, static-protective surface.
 - c. Remove the cover from the blade server.
 - d. Press and hold the light path diagnostics switch to relight the LEDs that were lit before you removed the blade server from the Bull Blade Chassis - Enterprise. The LEDs will remain lit for as long as you press the switch, to a maximum of 25 seconds.

Figure 2-1 shows the locations of error LEDs on the system board:

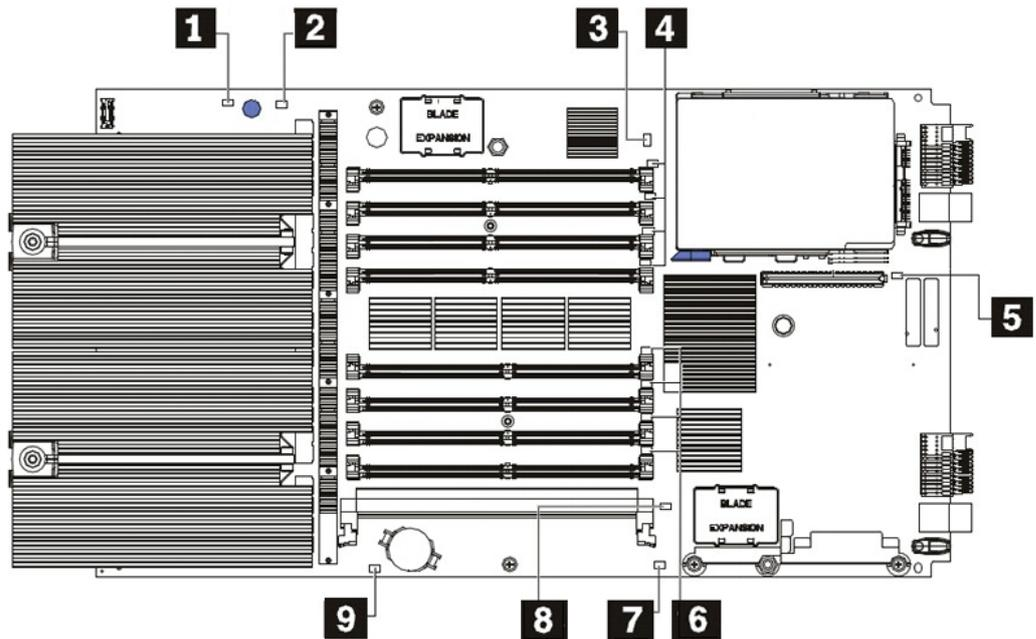

Figure 2-1. Light path diagnostic LEDs

Callout	System-board LEDs
1	Light path power LED.
2	System board LED (Px).
3	SAS hard disk drive LED or SAS solid-state drive LED.
4	DIMM 1-4 LEDs.
5	1Xe connector LED.
6	DIMM 5-8 error LEDs.
7	High speed expansion card LED.
8	Management card LED.
9	Battery LED.

2.11.2 Light path diagnostics LEDs

Light path diagnostics is a system of LEDs on the control panel and on the system board of the blade server. When an error occurs, LEDs are lit throughout the blade server. If the control panel indicates an error, use the descriptions of the LEDs to diagnose the problem and take corrective action.

Table 2-31 describes the LEDs on the system board and suggested actions for correcting any detected problems.

Table 2-31. . Light path diagnostic LED descriptions

Lit light path diagnostics LED	Description	Action
None	An error has occurred and cannot be isolated, or the service processor has failed.	An error has occurred that is not represented by a light path diagnostics LED. Check the management-module event log for information about the error.
Battery error P1-E1 BATT	A battery error occurred.	<ol style="list-style-type: none"> 1. Reseat the battery. 2. Replace the battery.
DIMM x error P1-C1 DIMM 1 P1-C2 DIMM 2 P1-C3 DIMM 3 P1-C4 DIMM 4 P1-C5 DIMM 5 P1-C6 DIMM 6 P1-C7 DIMM 7 P1-C8 DIMM 8	A memory error occurred.	<ol style="list-style-type: none"> 1. Verify that the DIMM indicated by the lit LED is a supported memory module. 2. Reseat the DIMM indicated by the lit LED. 3. Replace the DIMM indicated by the lit LED. <p>Note: Multiple DIMM LEDs do not necessarily indicate multiple DIMM failures. If more than one DIMM LED is lit, reseat or replace one DIMM at a time until the error goes away. See the <i>Hardware Maintenance Manual and Troubleshooting Guide</i> or <i>Problem Determination and Service Guide</i> for your Bull Blade Chassis - Enterprise for further isolation.</p>
Hard disk drive or solid state drive error P1-D1 SAS 0	A hard disk drive error occurred.	<ol style="list-style-type: none"> 1. Reseat the hard disk drive. 2. Replace the hard disk drive.
PCIe high speed expansion card error P1-C11 PCIe	An I/O expansion card option error occurred.	<ol style="list-style-type: none"> 1. Make sure that the I/O expansion option is supported. 2. Reseat the I/O expansion option. 3. Replace the I/O expansion option.
Management card error P1-C9 MGMT CRD	A system board error occurred.	<ol style="list-style-type: none"> 1. Replace the blade server cover, reinsert the blade server in the Bull Blade Chassis - Enterprise, and then restart the blade server. 2. Check the management-module event log for information about the error. 3. Replace the management card assembly. 4. Replace the system board and chassis assembly.

<ul style="list-style-type: none"> Follow the suggested actions in the order in which they are listed in the Action column until the problem is solved. See <i>Chapter 3, "Parts listing,"</i> on page 197 to determine which components are CRUs and which components are FRUs. If an action step is preceded by "(Trained service technician only)," that step must be performed only by a trained service technician. 		
Lit light path diagnostics LED	Description	Action
CIOv expansion card error P1-C12 1Xe	An I/O expansion card option error occurred.	<ol style="list-style-type: none"> Make sure that the I/O expansion option is supported. Reseat the I/O expansion option. Replace the I/O expansion option. <p>See "<i>PCI expansion card (PIOCARD) problem isolation procedure</i>" on page 164 for more information.</p>
System board error P1 SYS BRD	A system board and chassis assembly error has occurred. A microprocessor failure shows up as a system board and chassis assembly error.	<ol style="list-style-type: none"> Replace the blade server cover, reinsert the blade server in the Bull Blade Chassis - Enterprise, and then restart the blade server. Check the management-module event log for information about the error. Replace the system-board and chassis assembly.

2.12 Firmware problem isolation

Isolate a firmware problem.

To isolate a firmware problem, follow the procedure until the problem is solved.

- If the blade server is operating, shut down the operating system and turn off the blade server.
- Turn on the blade server.
If the problem no longer occurs, no further action is necessary. You are finished with this procedure.
- If the blade server boots up far enough to allow the installation of server firmware updates, check for appropriate updates and install them.
If you install updates, reboot the server and see if the problem still exists. If not, you are finished with this procedure.
- Recover the system firmware, as described in "*Recovering the system firmware*" on page 186.
- After recovering the system firmware, check for and install any server firmware updates.

2.13 Recovering the system firmware

The system firmware is contained in separate temporary and permanent images in the flash memory of the blade server. These images are referred to as TEMP and PERM, respectively. The blade server normally starts from the TEMP image, and uses the PERM image as a backup. If the TEMP image becomes damaged, such as from a power failure during a firmware update, you can recover the TEMP image from the PERM image.

If your system hangs, access the management module and select **Blade Tasks** → **Configuration** → **Boot Mode** to show the Escala BL460 blade server in the list of blade servers in the Bull Blade Chassis - Enterprise. Click the appropriate blade server and select **Permanent** to force the system to start from the PERM image.

See the documentation for the management module to learn more.

2.13.1 Starting the PERM image

You can force the blade server to start the PERM (permanent) image.

To force the blade server to start the PERM (permanent) image, complete the following procedure.

1. Access the Chassis Management Module menus.
2. Click **Blade Tasks** → **Configuration** → **Boot Mode**.
3. Click the appropriate Escala BL460 blade server in the list of blade servers in the Bull Blade Chassis - Enterprise.
4. Select **Permanent** to force the system to start from the PERM image.

See the documentation for the management module to learn more.

2.13.2 Starting the TEMP image

Start the TEMP image before you update the firmware.

Perform the following procedure to start the TEMP image.

1. Access the Chassis management module.
See the Management Module Command-Line Interface Reference Guide or the Blade Serial-Over-LAN Setup Guide for more information.
2. Click **Blade Tasks** → **Configuration** → **Boot Mode**.
3. Click the applicable Escala BL460 blade server in the list of blade servers in the Bull Blade Chassis - Enterprise.
4. Select **Temporary** to force the system to start from the TEMP image.
5. Restart the blade server.

6. Verify that the system starts from the TEMP image, as described in “Verifying the system firmware levels.”

2.13.3 Recovering the TEMP image from the PERM image

To recover the TEMP image from the PERM image, you must perform the reject function. The reject function copies the PERM image into the TEMP image.

To perform the reject function, complete the following procedure.

1. If you have not started the system from the PERM image, do so now. See “Starting the PERM image” on page 186.
2. Issue the appropriate command for your operating system to reject the TEMP image.
 - If you are using the Red Hat Linux or SUSE Linux operating system, type the following command:

```
update_flash -r
```
 - If you are using the AIX operating system, type the following command:

```
/usr/lpp/diagnostics/bin/update_flash -r
```
3. Start the TEMP image, as described in “Starting the TEMP image” on page 186.

You might need to update the firmware code to the latest version. See “Updating the firmware” on page 231 for more information about how to update the firmware code.

2.13.4 Verifying the system firmware levels

The diagnostics program displays the current system firmware levels for the TEMP and PERM images. This function also displays which image the blade server used to start up.

1. Start the diagnostics program.
See “Running the diagnostics program” on page 152.
2. From the **Function Selection** menu, select **Task Selection** and press Enter.
3. From the **Tasks Selection List** menu, select **Update and Manage System Flash** and press Enter.
The **Update and Manage System Flash** menu is displayed. The top of the window displays the system firmware level for the PERM and the TEMP images and the image that the blade server used to start.

Note If the TEMP image level is more current than the PERM image, commit the TEMP image.

See “Committing the TEMP system firmware image” on page 188.

4. When you have verified the firmware levels, press F3 until the Diagnostic Operating Instructions window is displayed; then press F3 again to exit the diagnostic program.

2.13.5 Committing the TEMP system firmware image

After updating the system firmware and successfully starting up the blade server from the TEMP image, copy the TEMP image to the PERM image using the diagnostics program commit function.

Note If you install the server firmware update permanently by committing the temporary firmware level from the temporary side to the permanent side, the temporary and permanent sides contain the same level of firmware. You cannot return to the level that was previously on the permanent side.

1. Load the diagnostics program. See “Running the diagnostics program” on page 152.
2. From the Function Selection menu, select **Task Selection** and press **Enter**.
3. From the Tasks Selection List menu, select **Update and Manage System Flash** and press **Enter**.
4. From the Update and Manage System Flash menu, select **Commit the Temporary Image** and press **Enter**.
5. When the commit function is complete, press **F3** until the Diagnostic Operating Instructions screen is displayed; then press **F3** again to exit the diagnostic program.

2.14 Solving shared Bull Blade Chassis – Enterprise resource problems

Problems with Bull Blade Chassis – Enterprise shared resources might appear to be in the blade server, but might actually be a problem in a Bull Blade Chassis - Enterprise component.

This information provides procedures to help you isolate blade server problems from shared resource problems.

If the problem is thought to be with a shared resource, see the *Problem Determination and Service Guide* or the *Hardware Maintenance Manual and Troubleshooting Guide* for your Bull Blade Chassis - Enterprise, or see the documentation for Bull Blade Chassis - Enterprise components for additional information. If the problem cannot be solved, see “*Solving undetermined problems*” on page 194.

To check the general function of shared resources, complete the following operations.

1. Verify that the Bull Blade Chassis - Enterprise has the required power modules installed and is connected to a working power source.
2. Verify that power management is set correctly for your Bull Blade Chassis - Enterprise configuration.
3. Verify whether the problem is being experienced on more than one blade server.

4. Perform a test of the failing function on a blade server that is known to be operational.
5. Try the blade server in a different blade bay.
6. Try a blade server that is known to be operational in the blade bay with the failing blade server.
7. Verify that the blade server and the monitor are powered on.
8. Check for keyboard problems, as described in "Solving shared keyboard problems."
9. Check for problems with the media tray (removable media drives and USB ports), as described in "Solving shared media tray problems" on page 190.
10. Check for network connection problems, as described in "Solving shared network connection problems" on page 192.
11. Check for power problems, as described in "Solving shared power problems" on page 193.
12. Check for video problems, as described in "Solving shared video problems" on page 193.

2.14.1 Solving shared keyboard problems

Problems with shared resources might appear to be in the blade server, but might actually be a problem in a Bull Blade Chassis - Enterprise keyboard component.

To check the general function of shared keyboard resources, perform the following procedure.

1. Verify that the keyboard/video select button LED on the front of the blade server is lit. A lit indicator shows that the blade server is connected to the shared keyboard.
2. Verify that the keyboard cable is securely connected to the active management module.
3. Verify that the keyboard works with another blade server.
4. Verify that the management module is operating correctly.
See the documentation for your Bull Blade Chassis - Enterprise.
Some Bull Blade Chassis - Enterprise types have several management-module components that you might test or replace.
See the *Installation Guide* for your management module for more information.
5. Replace the keyboard.
6. Replace the management module.
See the *Problem Determination and Service Guide* or the *Hardware Maintenance Manual and Troubleshooting Guide* for your Bull Blade Chassis - Enterprise.

If these steps do not resolve the problem, it is likely a problem with the blade server. See "Keyboard problems" on page 159 for more information.

2.14.2 Solving shared media tray problems

Problems with shared resources might appear to be in the blade server, but might actually be a problem in a Bull Blade Chassis - Enterprise media tray component.

To check the general function of shared Bull Blade Chassis – Enterprise media tray resources, perform the following procedure.

1. Verify that the media-tray select button LED on the front of the blade server is lit. A lit media-tray select button LED shows that the blade server is connected to the shared media tray.
2. Verify that the media tray devices work with another blade server.
3. Verify which components of the media tray are affected. Components include:
 - USB ports
 - Diskette drive
 - CD or DVD drive
4. Troubleshoot USB port problems if USB ports are the only failing component.
 - a. Make sure that the USB device is operational.
 - b. If using a USB hub, make sure that the hub is operating correctly and that any software the hub requires is installed.
 - c. Plug the USB device directly into the USB port, bypassing the hub, to check its operation.
 - d. Reseat the following components:
 - USB device cable
 - Media tray cable (if applicable)
 - Media tray
 - e. Replace the following components one at a time, in the order shown, restarting the blade server each time:
 - i. USB cable (if applicable)
 - ii. Media tray cable (if applicable)
 - iii. Media tray
5. Troubleshoot the diskette drive if it is the only failing component. If there is a diskette in the drive, make sure that:
 - The diskette is inserted correctly in the drive.
 - The diskette is good and not damaged; the drive LED light flashes once per second when the diskette is inserted. (Try another diskette if you have one.)
 - The diskette contains the necessary files to start the blade server.
 - The software program is working properly.

- The distance between monitors and diskette drives is at least 76 mm (3 in).
6. Troubleshoot the CD or DVD drive if it is the only failing component.
 - Verify that the CD or DVD is inserted correctly in the drive. If necessary, insert the end of a straightened paper clip into the manual tray-release opening to eject the CD or DVD. The drive LED light flashes once per second when the CD or DVD is inserted.
 - Verify that the CD or DVD is clean and not damaged. (Try another CD or DVD if you have one.)
 - Verify that the software program is working properly.
 7. Troubleshoot one or more of the removable media drives if they are the only failing components.
 - Reseat the following components:
 - Removable-media drive cable (if applicable)
 - Removable-media drive
 - Media tray cable (if applicable)
 - Media tray
 8. Replace the following components one at a time, in the order shown, restarting the blade server each time:
 - a. Removable-media drive cable (if applicable)
 - b. Media tray cable (if applicable)
 - c. Removable-media drive
 - d. Media tray
 9. Verify that the management module is operating correctly.

See the *Problem Determination and Service Guide* or the *Hardware Maintenance Manual and Troubleshooting Guide* for your Bull Blade Chassis - Enterprise. Some Bull Blade Chassis - Enterprise types have several management-module components that you might test or replace. See the *Installation Guide* for your management module for more information.
 10. Replace the management module.

See the *Problem Determination and Service Guide* or the *Hardware Maintenance Manual and Troubleshooting Guide* for your Bull Blade Chassis - Enterprise.

If these steps do not resolve the problem, it is likely a problem with the blade server. See “*Universal Serial Bus (USB) port problems*” on page 181 for more information.

2.14.3 Solving shared network connection problems

Problems with shared resources might appear to be in the blade server, but might actually be a problem in a Bull Blade Chassis - Enterprise network connection resource.

To check the general function of shared Bull Blade Chassis – Enterprise network connection resources, perform the following procedure.

1. Verify that the network cables are securely connected to the I/O module.
2. Verify that the network cables are securely connected to the I/O module.
3. Verify that the power configuration of the Blade Chassis supports the I/O module configuration.
4. Verify that the installation of the I/O-module type is supported by the Blade Chassis and blade server hardware.
5. Verify that the I/O modules for the network interface are installed in the correct blade bays.
6. Verify that the I/O modules for the network interface are configured correctly.
7. Verify that the settings in the I/O module are correct for the blade server.
Some settings in the I/O module are specifically for each blade server.
8. Verify that the I/O modules for the network interface are operating correctly.
Troubleshoot and replace the I/O module as indicated in the documentation for the I/O module.
9. Verify that the management module is operating correctly.
See the *Problem Determination and Service Guide* or the *Hardware Maintenance Manual and Troubleshooting Guide* for your Bull Blade Chassis - Enterprise.
Some Bull Blade Chassis - Enterprise types have several management-module components that you might test or replace. See the *Installation Guide* for your management module for more information
10. Replace the management module.
See the the *Problem Determination and Service Guide* or the *Hardware Maintenance Manual and Troubleshooting Guide* for your Bull Blade Chassis - Enterprise.

If these steps do not resolve the problem, it is likely a problem with the blade server. See “*Network connection problems*” on page 163 for more information.

2.14.4 Solving shared power problems

Problems with shared resources might appear to be in the blade server, but might actually be a problem in a Bull Blade Chassis - Enterprise power component.

To check the general function of shared power resources, perform the following procedure.

1. Verify that the LEDs on all the Blade Chassis power modules are lit.
2. Verify that power is being supplied to the Bull Blade Chassis - Enterprise.
3. Verify that the installation of the blade server type is supported by the Bull Blade Chassis - Enterprise.
4. Verify that the power configuration of the Bull Blade Chassis - Enterprise supports the blade bay where your blade server is installed.
5. Verify that the Bull Blade Chassis - Enterprise power management configuration and status support blade server operation.
See the Management Module User's Guide or the Management Module Command-Line Interface Reference Guide for more information.
6. Verify that the local power control for the blade server is set correctly.
See the Management Module User's Guide or the Management Module Command-Line Interface Reference Guide for more information.
7. Verify that the Bull Blade Chassis - Enterprise blowers are correctly installed and operational.

If these steps do not resolve the problem, it is likely a problem with the blade server. See "Power problems" on page 165 for more information.

2.14.5 Solving shared video problems

Problems with shared resources might appear to be in the blade server, but might actually be a problem in a Bull Blade Chassis - Enterprise video component.

Some monitors have their own self-tests. If you suspect a problem with the monitor, see the information that comes with the monitor for instructions for adjusting and testing the monitor.

To check for video problems, perform the following procedure.

1. Verify that the monitor brightness and contrast controls are correctly adjusted.
2. Verify that the keyboard/video select button LED on the front of the blade server is lit. A lit indicator shows that the blade server is connected to the shared blade chassis monitor.
3. Verify that the video cable is securely connected to the management-module. Non-Bull monitor cables might cause unpredictable problems.

4. Verify that the monitor works with another blade server.
5. Move the device and the monitor at least 305 mm (12 in.) apart, then turn on the monitor.

Attention: Moving a color monitor while it is turned on might cause screen discoloration.

If the monitor self-tests show that the monitor is working correctly, the location of the monitor might be affecting its operation. Magnetic fields around other devices (such as transformers, appliances, fluorescent lights, and other monitors) can cause screen jitter or wavy, unreadable, rolling, or distorted screen images. If this happens, turn off the monitor.

6. Verify that the management module is operating correctly.
See the documentation for your Bull Blade Chassis - Enterprise.
Some Bull Blade Chassis - Enterprise types have several management-module components that you might test or replace.
See the *Installation Guide* for your management module for more information.
7. Replace the monitor cable, if applicable.
8. Replace the monitor.
9. Replace the management module.
See the *Problem Determination and Service Guide* or the *Hardware Maintenance Manual and Troubleshooting Guide* for your Bull Blade Chassis - Enterprise.

If these steps do not resolve the problem, it is likely a problem with the blade server. See "Monitor or video problems", on page 162 for more information.

2.15 Solving undetermined problems

When you are diagnosing a problem in the Escala BL460 blade server, you must determine whether the problem is in the blade server or in the Bull Blade Chassis - Enterprise.

- If all of the blade servers have the same symptom, it is probably a Blade Chassis - Enterprise problem; for more information, See the *Hardware Maintenance Manual and Troubleshooting Guide* or *Problem Determination and Service Guide* for your Bull Blade Chassis - Enterprise.
- If the Bull Blade Chassis - Enterprise contains more than one blade server and only one of the blade servers has the problem, troubleshoot the blade server that has the problem.

Check the LEDs on all the power supplies of the Bull Blade Chassis - Enterprise where the blade server is installed. If the LEDs indicate that the power supplies are working correctly, and reseating the blade server does not correct the problem, complete the following steps:

1. Make sure that the control panel connector is correctly seated on the system board.
See "System-board connectors" on page 12 for the location of the connector.

2. If no LEDs on the control panel are working, replace the bezel assembly; then, try to power-on the blade server from the Management Module Web interface. See the *Management Module User's Guide* for more information.
3. Turn off the blade server.
4. Remove the blade server from the Bull Blade Chassis - Enterprise and remove the cover.
5. Remove or disconnect the following devices, one at a time, until you find the failure. Reinstall, turn on, and reconfigure the blade server each time.
 - I/O expansion option.
 - Hard disk drives.
 - Memory modules. The minimum configuration requirement is 2 GB (two 1 GB DIMMs).The following minimum configuration is required for the blade server to start:
 - System-board and chassis assembly (with two microprocessors)
 - Two 2 GB DIMMs
 - A functioning Bull Blade Chassis - Enterprise
6. Install and turn on the blade server. If the problem remains, suspect the following components in order:
 - a. DIMM
 - b. System-board and chassis assembly

If the problem is solved when you remove an I/O expansion option from the blade server but the problem recurs when you reinstall the same expansion option, suspect the expansion option; if the problem recurs when you replace the expansion option with a different one, suspect the System-board and chassis assembly.

If you suspect a networking problem and the blade server passes all the system tests, suspect a network cabling problem that is external to the system.

2.16 Calling Bull for service

Call Bull for service after you collect as much as possible of the following information.

Before calling for service, collect as much as possible of the following available information:

- Machine type and model
- Hard disk drive upgrades
- Failure symptoms:
 - Does the blade server fail the diagnostic programs? If so, what are the error codes?
 - What occurs? When? Where?
 - Is the failure repeatable?
 - Has the current server configuration ever worked?
 - What changes, if any, were made before it failed?
 - Is this the original reported failure, or has this failure been reported before?
- Diagnostic program type and version level
- Hardware configuration (print screen of the system summary)
- Firmware level
- Operating-system type and version level

You can solve some problems by comparing the configuration and software setups between working and nonworking blade server. When you compare blade servers to each other for diagnostic purposes, consider them identical only if all the following factors are exactly the same in all of the blade servers:

- Machine type and model
- Firmware level
- Adapters and attachments, in the same locations
- Address cabling
- Software versions and levels
- Diagnostic program type and version level
- Configuration option settings
- Operating-system control-file setup

Chapter 3. Parts listing

The parts listing identifies each replaceable part, part number, and replaceable component type.

Figure 3-1 shows replaceable components that are available for the Escala BL460 blade server.

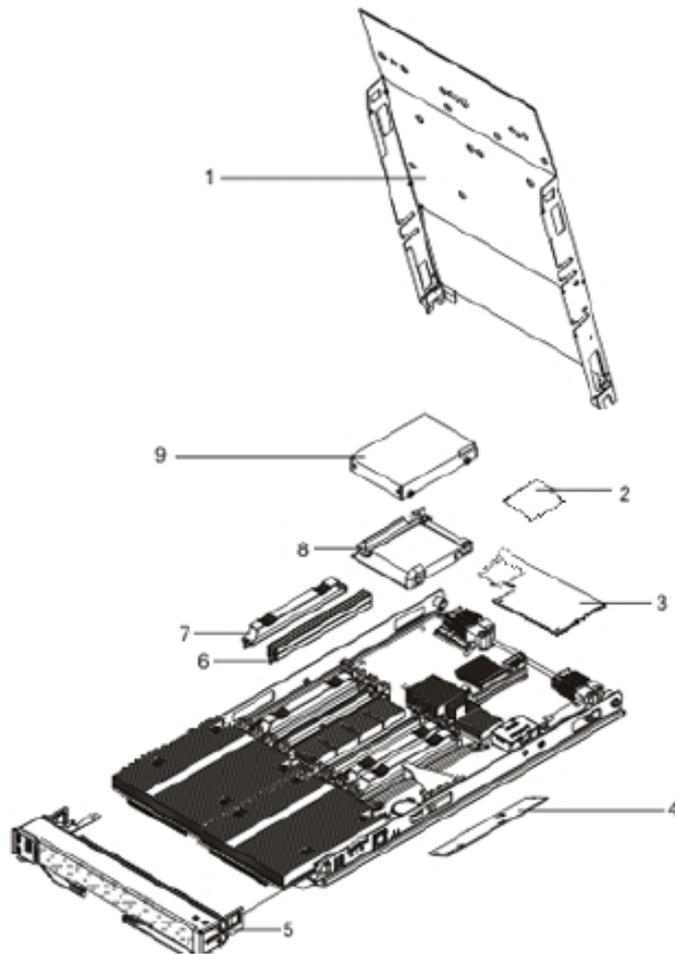

Figure 3-1. Parts illustration

Replaceable components are of three types:

- **Tier 1 customer replaceable unit (CRU):** Replacement of Tier 1 CRUs is your responsibility. If Bull installs a Tier 1 CRU at your request, you will be charged for the installation.
- **Tier 2 customer replaceable unit:** You may install a Tier 2 CRU yourself or request Bull to install it, at no additional charge, under the type of warranty service that is designated for your blade server.
- **Field replaceable unit (FRU):** FRUs must be installed only by trained service technicians.

For information about the terms of the warranty and getting service and assistance, see the *Warranty and Support Information* document.

Table 3-1. Parts table

Index	Description	CRU part number		Failing Feature Code (FFC)
		(Tier 1)	(Tier 2)	
	Base system-board and chassis assembly, with 2 POWER6 dual-core microprocessors		10N9856	Various, see "Failing function codes 151 through 2D02" on page 144
1	Cover	42D8680		
2	3Gb SAS Passthrough Expansion Card (CIOv) (option)	46C4069		2506
2	QLogic 4Gb Fibre Channel 1Xe PCI-Express Expansion Card (CIOv) (option)	46M6068		2E13
2	QLogic 8Gb Fibre Channel 1Xe PCI-Express Expansion Card (CIOv) (option)	44X1948		2E14
2	Emulex 8Gb Fibre Channel Expansion Card (CIOv) (option)	46M6138		2607
3	4X InfiniBand DDR Expansion Card (CFFh) for BladeCenter (option)	7778-8258		
3	Voltaire 4x InfiniBand DDR Expansion Card (CFFh) for BladeCenter (option)	7778-8298		
3	Combo 4Gb Fibre Channel Expansion Card, 1 GB Ethernet Card, (CFFh/PCIe) (option)	39Y9304		
3	QLogic 8Gb Fibre Channel Expansion Card, (CFFh/PCIe) (option)	44X1943		2E12
4	Management card (base system board only)	07P6897		
5	Bezel assembly with control panel	44V6916		
5	OEM Bezel assembly with control panel	44V6917		
6	Memory, 2 GB DDR2, 667 MHz very low profile (VLP) RDIMM (option)	46C0518		219 2C6
6	Memory, 4 GB DDR2, 667 MHz VLP RDIMM (option)	46C0519		219 2C6
6	Memory, 8 GB DDR2, 400 MHz VLP RDIMM (option)	46C0517		219 2C6
7	DIMM filler	40K5989		
8	Tray, SAS hard disk drive	31R2239		
9	Hard disk drive, 73 GB 10K RPM SFF SAS HDD and screws (4)	26K5779		2553
9	Hard disk drive, 146 GB 10K RPM SFF SAS HDD and screws (4) (option)	42D0422		2553

9	Hard disk drive, 300 GB 10K RPM SFF SAS HDD and screws (4) (option)	42D0628		2553
9	Solid State Drive (SSD) 69 GB and screws (4) (option)	44V6825		2553
9	Disk drive filler	40K5928		
	Label, FRU list	44V7312		
	Label, OEM FRU list	44V7313		
	Label, System service	44V6772		
	Kit, Universal -miscellaneous parts	32R2451		
	Battery, 3.0 volt	33F8354		151

Chapter 4. Removing and replacing blade server components

Use this information to remove and replace components of the ESCALA BL460 blade server that are replaceable.

Replaceable components are of three types:

- **Tier 1 customer replaceable unit (CRU):** Replacement of Tier 1 CRUs is your responsibility. If Bull installs a Tier 1 CRU at your request, you will be charged for the installation.
- **Tier 2 customer replaceable unit:** You may install a Tier 2 CRU yourself or request Bull to install it, at no additional charge, under the type of warranty service that is designated for your blade server.
- **Field replaceable unit (FRU):** FRUs must be installed only by trained service technicians.

See *Chapter 3, "Parts listing,"* on page 197 to determine whether a part is a Tier 1 CRU, Tier 2 CRU, or FRU component.

For information about the terms of the warranty and getting service and assistance, see the *Warranty and Support Information* document.

4.1 Installation guidelines

Follow these guidelines to remove and replace blade server components.

- Read the Safety Attention in "*Safety*" on page vii and the guidelines in "*Handling static-sensitive devices*" on page 202. This information will help you work safely.
- When you install a new blade server, download and apply the most recent firmware updates.

Download and install updated device drivers and the Escala BL460 blade server firmware. Go to the Bull Support site (<http://www.bull.com/support/>) to download the updates.

- Observe good housekeeping in the area where you are working. Place removed covers and other parts in a safe place.
- Back up all important data before you make changes to disk drives.
- Before you remove a hot-swap blade server from the Bull Blade Chassis - Enterprise, you must shut down the operating system and turn off the blade server. You do not have to shut down the Bull Blade Chassis - Enterprise itself.
- Blue on a component indicates touch points, where you can grip the component to remove it from or install it in the blade server, open or close a latch, and so on.

- Orange on a component or an orange label on or near a component indicates that the component can be hot-swapped, which means that if the blade server and operating system support hot-swap capability, you can remove or install the component while the blade server is running. (Orange can also indicate touch points on hot-swap components.) See the instructions for removing or installing a specific hot-swap component for any additional procedures that you might have to perform before you remove or install the component.
- When you are finished working on the blade server, reinstall all safety shields, guards, labels, and ground wires.

4.1.1 System reliability guidelines

Follow these guidelines to help ensure proper cooling and system reliability.

- Verify that the ventilation holes on the blade server are not blocked.
- Verify that you are maintaining proper system cooling in the unit.
Do not operate the Bull Blade Chassis - Enterprise without a blade server, expansion unit, or filler blade installed in each blade bay. See the documentation for your Bull Blade Chassis - Enterprise for additional information.
- Verify that you have followed the reliability guidelines for the Bull Blade Chassis - Enterprise.
- Verify that the blade server battery is operational. If the battery becomes defective, replace it immediately, as described in *"Removing the battery"* on page 224 and *"Installing the battery"* on page 225.

4.1.2 Handling static-sensitive devices



Attention:

Static electricity can damage the blade server and other electronic devices. To avoid damage, keep static-sensitive devices in their static-protective packages until you are ready to install them.

To reduce the possibility of damage from electrostatic discharge, observe the following precautions:

- Limit your movement. Movement can cause static electricity to build up around you.
- Handle the device carefully, holding it by its edges or its frame.
- Do not touch solder joints, pins, or exposed circuitry.
- Do not leave the device where others can handle and damage it.
- While the device is still in its static-protective package, touch it to an unpainted metal part of the Bull Blade Chassis - Enterprise or any unpainted metal surface on any other grounded rack component in the rack you are installing the device in for at least 2 seconds. This drains static electricity from the package and from your body.

- Remove the device from its package and install it directly into the blade server without setting down the device. If it is necessary to set down the device, put it back into its static-protective package. Do not place the device on the blade server cover or on a metal surface.
- Take additional care when handling devices during cold weather. Cooling reduces indoor humidity and increases static electricity..

4.1.3 Returning a device or component

If you are instructed to return a device or component, follow all packaging instructions, and use any packaging materials for shipping that are supplied to you.

4.2 Removing the blade server from a Bull Blade Chassis - Enterprise

Remove the blade server from the Bull Blade Chassis - Enterprise to access options, connectors, and system-board indicators.

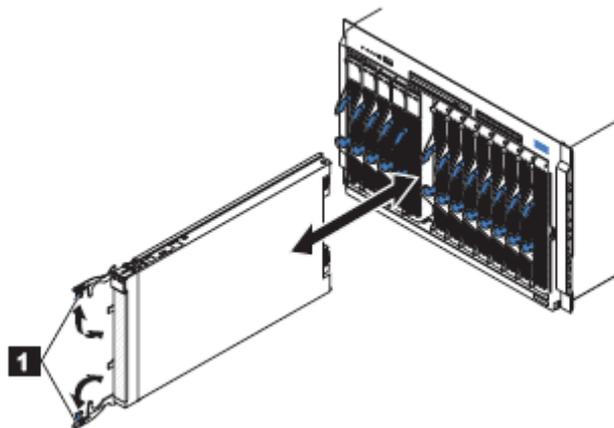

Figure 4-1. Removing the blade server from the Bull Blade Chassis - Enterprise



Attention:

- To maintain proper system cooling, do not operate the Bull Blade Chassis - Enterprise without a blade server, expansion unit, or blade filler installed in each blade bay.
- When you remove the blade server, note the bay number. Reinstalling a blade server into a different bay from the one where it was removed might have unintended consequences. Some configuration information and update options are established according to bay numbers. If you reinstall the blade server into a different bay, you might have to reconfigure the blade server.

Perform the following procedure to remove the blade server.

1. Read "Safety" on page vii and the "Installation guidelines" on page 201.
2. If the blade server is operating, shut down the operating system.

3. Press the power-control button (behind the control-panel door) to turn off the blade server. See *"Turning off the blade server"* on page 11.
4. Wait at least 30 seconds for the hard disk drive to stop spinning.
5. Open the two release handles as shown in the illustration. The blade server moves out of the bay approximately 0.6 cm (0.25 inch).
6. Pull the blade server out of the bay. Spring-loaded doors farther back in the bay move into place to cover the bay temporarily.
7. Carefully lay the blade server on a flat, static-protective surface, with the cover side up.
8. Place either a blade filler or another blade server in the bay within 1 minute. The recessed spring-loaded doors move out of the way as you insert the blade server or filler blade.

4.3 Installing the blade server in a Bull Blade Chassis - Enterprise

Install the blade server in a Bull Blade Chassis - Enterprise to use the blade server.

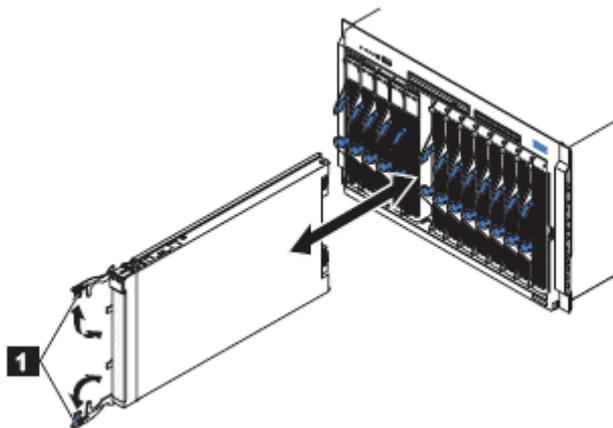

Figure 4-2. Installing the blade server in a Bull Blade Chassis - Enterprise

Statement 21:



CAUTION:

Hazardous energy is present when the blade is connected to the power source. Always replace the blade cover before installing the blade.

Perform the following procedure to install a blade server in a Bull Blade Chassis - Enterprise.

1. Download the firmware so that you can use it later to update the blade server after you start it.
2. Read *"Safety"* on page vii and the *"Installation guidelines"* on page 201.

3. If you have not done so already, install any optional devices that you want, such as a SAS drive or memory modules.
4. Select the bay for the blade server.
 - See the documentation that comes with your Bull Blade Chassis - Enterprise to verify that the bay you choose is powered.
 - Ensure proper cooling, performance, and system reliability by installing a blade server, expansion unit, or blade filler in each blade bay.
 - Reinstall a blade server in the same blade bay to preserve some configuration information and update options that are established by blade bay. Reinstalling into a different blade bay can have unintended consequences, which might include reconfiguring the blade server.
5. Verify that the release handles on the blade server are in the open position (perpendicular to the blade server) as shown in **1** in *Figure 4-2* on page 204.
6. If you installed a filler blade or another blade server in the bay from which you removed the blade server, remove it from the bay.
7. Slide the blade server into the blade bay from which you removed it until the blade server stops.

The spring-loaded doors farther back in the bay that cover the bay opening move out of the way as you insert the blade server.
8. Push the release handles on the front of the blade server to close and lock them.

The discovery and initialization process can take up to three minutes to complete. The discovery and initialization process is complete when the green LED stops flashing rapidly and begins to flash slowly. At this point, you can power on the blade server.
9. Turn on the blade server. See *"Turning on the blade server"* on page 10.
10. Verify that the power-on LED on the blade server control panel is lit continuously. The continuous light indicates that the blade server is receiving power and is turned on.
11. Optional: Write identifying information on one of the user labels that come with the blade servers and place the label on the Bull Blade Chassis - Enterprise bezel.



Do not place the label on the blade server or in any way block the ventilation holes on the blade server. See the documentation that comes with your Bull Blade Chassis - Enterprise for information about label placement.

12. Use the SMS Utility program to configure the blade server. See *"Using the SMS utility"* on page 234.
13. Also use the management module to configure the blade server. See the documentation for the management module to understand the functions that the management module provides.

If you have changed the configuration of the blade server or if this is a different blade server than the one you removed, you must configure the blade server. You might also have to install the blade server operating system.

See the *Installation and User's Guide* for detailed information about these tasks.

4.4 Removing and replacing Tier 1 CRUs

Replacement of Tier 1 customer-replaceable units (CRUs) is your responsibility.

If Bull installs a Tier 1 CRU at your request, you will be charged for the installation.

The illustrations in this documentation might differ slightly from your hardware.

4.4.1 Removing the blade server cover

Remove the blade server from the chassis unit and press the blade server cover releases to open and remove the blade server cover.

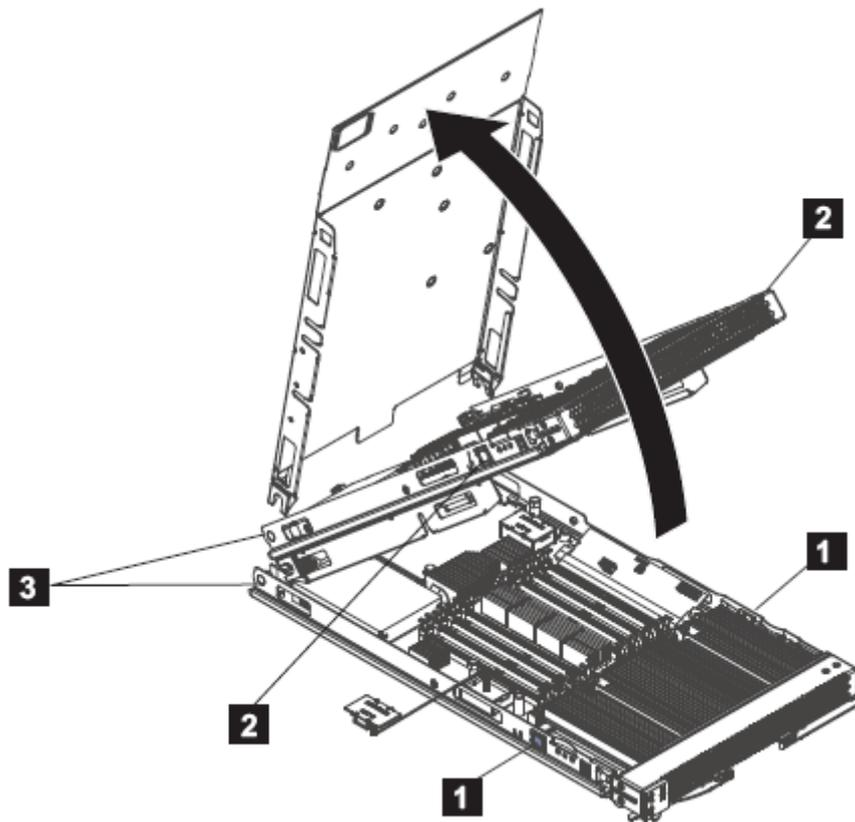

Figure 4-3. Removing the cover

Perform the following procedure to open and remove the blade server cover.

1. Read "Safety" on page vii and the "Installation guidelines" on page 201.

2. Shut down the operating system, turn off the blade server, and remove the blade server from the Bull Blade Chassis - Enterprise. See "*Removing the blade server from a Bull Blade Chassis - Enterprise*" on page 203.
3. Carefully lay the blade server on a flat, static-protective surface, with the cover side up.
4. Press the blade-cover release (as shown by **1**) on each side of the blade server, rotate the cover on the cover pins (**3**) and lift the cover open.
5. Lay the cover flat, or lift it from the blade server and store it for future use.

Statement 21



CAUTION:

Hazardous energy is present when the blade server is connected to the power source. Always replace the blade server cover before installing the blade server.

4.4.2 Installing and closing the blade server cover

Install and close the cover of the blade server before you insert the blade server into the Bull Blade Chassis - Enterprise. Do not attempt to override this important protection.

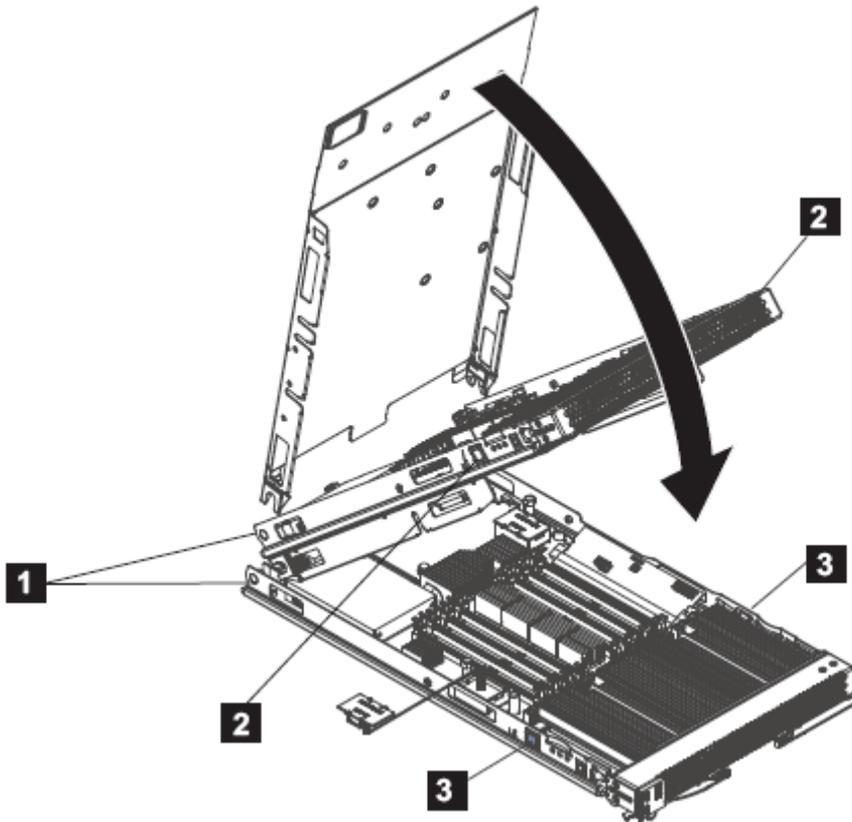

Figure 4-4. Installing the cover

Statement 21



CAUTION:

Hazardous energy is present when the blade server is connected to the power source. Always replace the blade server cover before installing the blade server.

Perform the following procedure to replace and close the blade server cover.

1. Read "Safety" on page vii and the "Installation guidelines" on page 201.
2. Lower the cover so that the slots at the rear slide down onto the pins (**1**) at the rear of the blade server. Before you close the cover, verify that all components are installed and seated correctly and that you have not left loose tools or parts inside the blade server.
3. Pivot the cover to the closed position until the releases (**3**) click into place in the cover.

4. Install the blade server into the Bull Blade Chassis - Enterprise. See *Installing the blade server in a Bull Blade Chassis - Enterprise*, on page 204.

4.4.3 Removing the bezel assembly

Remove the bezel assembly.

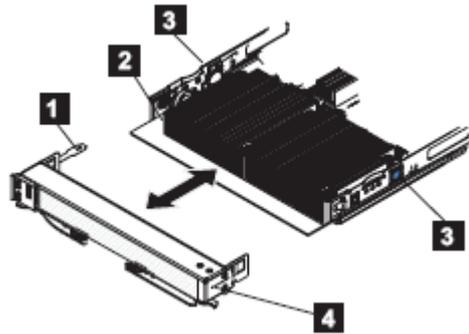

Figure 4-5. Removing the bezel assembly

1. Read "Safety" on page vii and the "Installation guidelines" on page 201.
2. Shut down the operating system, turn off the blade server, and remove the blade server from the Bull Blade Chassis - Enterprise. See "Removing the blade server from a Bull Blade Chassis - Enterprise" on page 203.
3. Carefully lay the blade server on a flat, static-protective surface, with the cover side up.
4. Open and remove the blade server cover. See "Removing the blade server cover", on page 206.
5. Press the bezel-assembly release (as shown by **3**) on each side of the blade server and pull the bezel assembly (**4**) away from the blade server approximately 1.2 cm (0.5 inch).
6. Disconnect the control-panel cable (**1**) from the control-panel connector (**2**).
7. Pull the bezel assembly away from the blade server.
8. If you are instructed to return the bezel assembly, follow all packaging instructions, and use any packaging materials for shipping that are supplied to you.

4.4.4 Installing the bezel assembly

Install the bezel assembly.

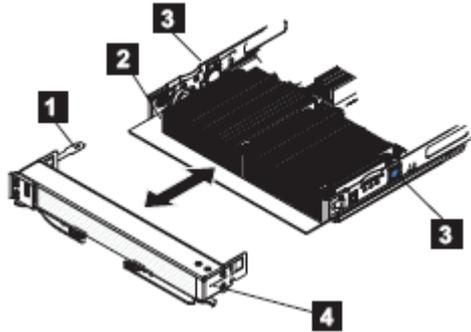

Figure 4-6. Installing the bezel assembly

1. Connect the control-panel cable (**1**) to the control-panel connector (**2**) on the system board.
2. Carefully slide the bezel assembly (**4**) onto the blade server until the two bezel-assembly releases (**3**) click into place in the bezel assembly.
3. Install and close the blade server cover. See “*Installing and closing the blade server cover*” on page 208.

Statement 21



CAUTION:

Hazardous energy is present when the blade server is connected to the power source. Always replace the blade server cover before installing the blade server.

4. Install the blade server into the Bull Blade Chassis - Enterprise. See *Installing the blade server in a Bull Blade Chassis - Enterprise*, on page 204.

4.4.5 Removing a drive

You can remove the SAS hard disk drive or the solid state drive (SSD).

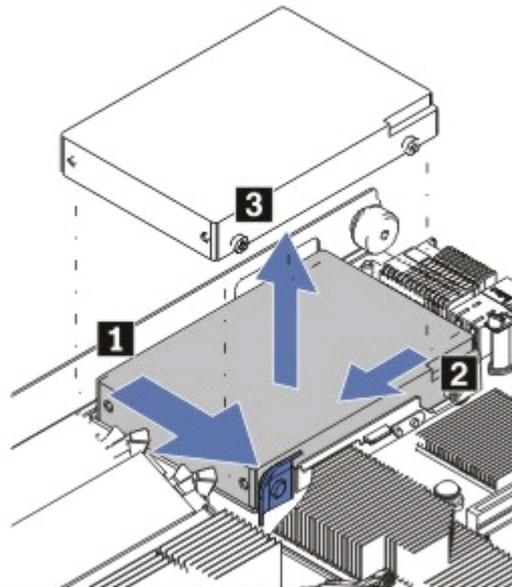

Figure 4-7. Removing a SAS hard disk

Perform the following procedure to remove a drive.

1. Back up the data from the drive to another storage device.
2. Read "Safety" on page *vii* and the "Installation guidelines" on page 201.
3. Shut down the operating system, turn off the blade server, and remove the blade server from the Bull Blade Chassis - Enterprise. See "Removing the blade server from a Bull Blade Chassis - Enterprise" on page 203.
4. Carefully lay the blade server on a flat, static-protective surface, with the cover side up.
5. Open and remove the blade server cover. See "Removing the blade server cover", on page 206.
6. Remove the drive:
 - a. Pull and hold the blue release lever **1** at the front of the hard disk drive tray.
 - b. Slide the drive forward **2** to disengage the connector.
 - c. Lift the drive **3** out of the drive tray.

4.4.6 Installing a drive

You can install a hard disk drive or a solid state drive (SSD).

Figure 4-8 shows how to install the SAS drive.

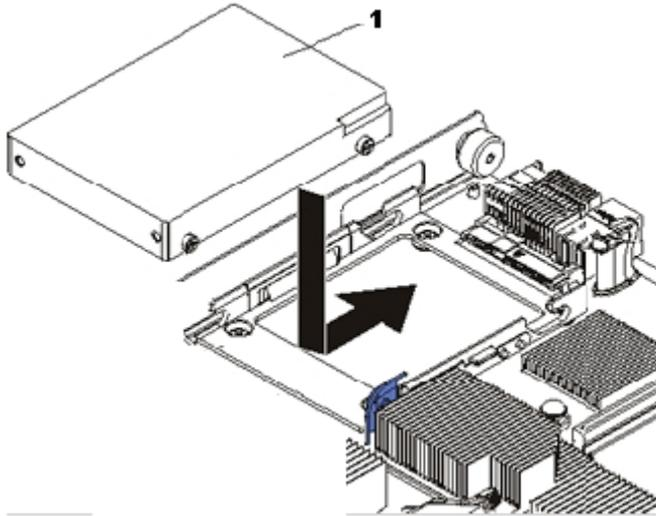

Figure 4-8. Installing a SAS hard disk

To install a drive, complete the following steps:

1. Read "Safety" on page vii and the "Installation guidelines" on page 201.
2. Shut down the operating system, turn off the blade server, and remove the blade server from the Bull Blade Chassis - Enterprise. See "Removing the blade server from a Bull Blade Chassis - Enterprise" on page 203.
3. Carefully lay the blade server on a flat, static-protective surface, with the cover side up.
4. Open and remove the blade server cover. See "Removing the blade server cover", on page 206.
5. Locate the connector for the drive.
6. Place the drive **1** into the hard disk drive tray and push it toward the rear of the blade, into the connector until the drive moves past the lever at the front of the tray.
Attention: Do not press on the top of the drive. Pressing the top might damage the drive.

7. Install and close the blade server cover. See *"Installing and closing the blade server cover"* on page 208.

Statement 21



CAUTION:

Hazardous energy is present when the blade server is connected to the power source. Always replace the blade server cover before installing the blade server.

8. Install the blade server into the Bull Blade Chassis - Enterprise. See *"Installing the blade server in a Bull Blade Chassis - Enterprise"* on page 204.

4.4.7 Removing a memory module

You can remove a very low profile (VLP) dual-inline memory module (DIMM).

1. Read *"Safety"* on page vii and the *"Installation guidelines"* on page 201.
2. Shut down the operating system, turn off the blade server, and remove the blade server from the Bull Blade Chassis - Enterprise. See *"Removing the blade server from a Bull Blade Chassis - Enterprise"* on page 203.
3. Carefully lay the blade server on a flat, static-protective surface, with the cover side up.
4. Open and remove the blade server cover. See *"Removing the blade server cover"*, on page 206.
5. Locate the DIMM connector that contains the DIMM that is to be replaced.

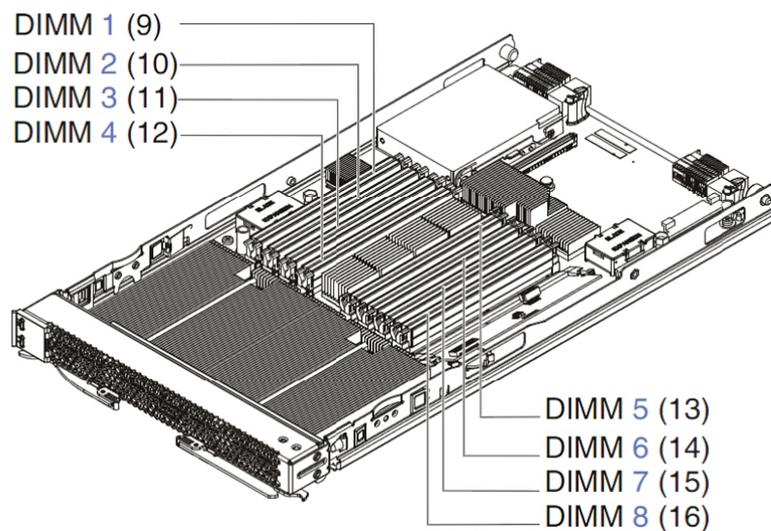

Figure 4-9. DIMM connectors

Attention: To avoid breaking the DIMM retaining clips or damaging the DIMM connectors, open and close the clips gently.

6. Carefully open the retaining clips on each end of the DIMM connector and remove the DIMM.
7. If you are instructed to return the DIMM, follow all packaging instructions, and use any packaging materials for shipping that are supplied to you.

4.4.8 Installing a memory module

Install dual inline memory modules (DIMMs) in the blade server.

The following table shows allowable placement of DIMM modules.

DIMM count	BL460 Blade planar (P1) DIMM slots							
	1	2	3	4	5	6	7	8
2	X		X					
4	X		X			X		X
6	X	X	X	X		X		X
8	X	X	X	X	X	X	X	X

Table 4-1. Memory module combination

See “Supported DIMMs” on page 5 for additional information about the type of memory that is compatible with the blade server.

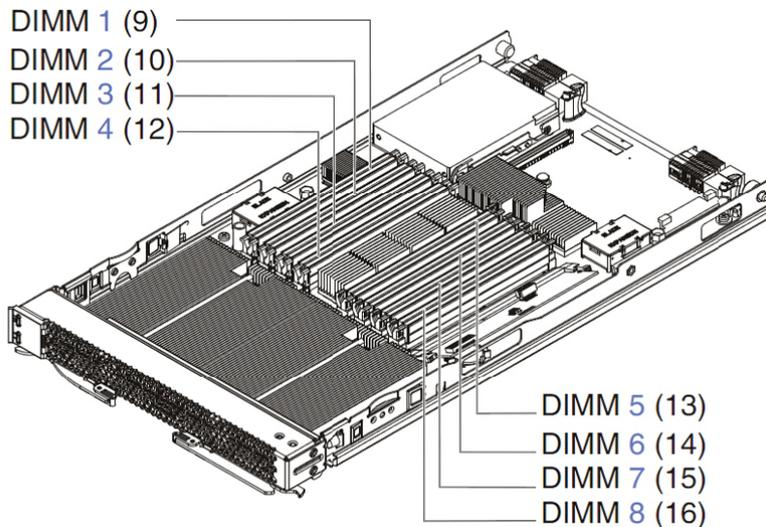

Figure 4-10. DIMM connectors

Perform the following procedure to install a DIMM.

1. Read “Safety” on page vii and the “Installation guidelines” on page 201.
2. Read the documentation that comes with the DIMMs.

3. Shut down the operating system, turn off the blade server, and remove the blade server from the Bull Blade Chassis - Enterprise. See *"Removing the blade server from a Bull Blade Chassis - Enterprise"* on page 203.
4. Carefully lay the blade server on a flat, static-protective surface, with the cover side up.
5. Open and remove the blade server cover. See *"Removing the blade server cover"*, on page 206.
6. Locate the DIMM connectors on the system board. See the illustration in *"System-board connectors"* on page 12. Determine the connector into which you will install the DIMM.
7. Touch the static-protective package that contains the part to any *unpainted* metal surface on the Bull Blade Chassis - Enterprise or any *unpainted* metal surface on any other grounded rack component; then, remove the part from its package.
8. Verify that both of the connector retaining clips are in the fully open position.
9. Turn the DIMM so that the DIMM keys align correctly with the connector on the system board.
Attention: To avoid breaking the DIMM retaining clips or damaging the DIMM connectors, handle the clips gently.
10. Insert the DIMM by pressing the DIMM along the guides into the connector. Verify that each retaining clip snaps into the closed position.
Important: If there is a gap between the DIMM and the retaining clips, the DIMM is not correctly installed. Open the retaining clips to remove and reinsert the DIMM.
11. Install and close the blade server cover. See *"Installing and closing the blade server cover"* on page 208.

Statement 21



CAUTION:

Hazardous energy is present when the blade server is connected to the power source. Always replace the blade server cover before installing the blade server.

12. Install the blade server into the Bull Blade Chassis - Enterprise. See *Installing the blade server in a Bull Blade Chassis - Enterprise*, on page 204.

4.4.9 Removing the management card

Remove the management card.

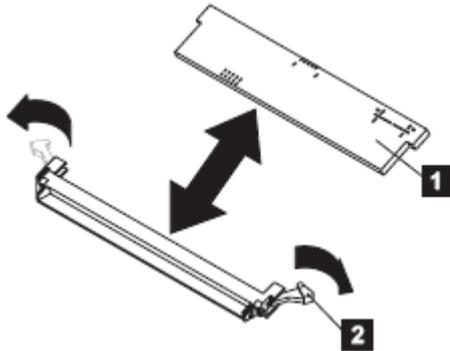

Figure 4-11. Removing the management card

Perform the following procedure to remove the management card, which is shown by (**1**) in the figure above.

1. Read "Safety" on page vii and the "Installation guidelines" on page 201.
2. Shut down the operating system, turn off the blade server, and remove the blade server from the Bull Blade Chassis - Enterprise. See "Removing the blade server from a Bull Blade Chassis - Enterprise" on page 203.
3. Carefully lay the blade server on a flat, static-protective surface, with the cover side up.
4. Open and remove the blade server cover. See "Removing the blade server cover", on page 206.
5. Locate the management card connector.
See "System-board connectors" on page 12 for the management card slot location.
Attention: To avoid breaking the card retaining clips (**2**) or damaging the management card connectors, open and close the clips gently.
6. Carefully open the retaining clips on each end of the management card connector and remove the management card.
7. If you are instructed to return the management card, follow all packaging instructions, and use any packaging materials for shipping that are supplied to you.
8. Move the management card to a new system board and chassis assembly.
If you are directed to move the management card to a new system board and chassis assembly, perform the following procedure.
 - a. Replace the system board and chassis assembly, as described in "Replacing the Tier 2 system-board and chassis assembly" on page 229.
 - b. Replace the management card, as described in "Installing the management card" on page 217.

4.4.10 Installing the management card

Use this procedure to install the management card into the currently installed system board. If you are also installing a new system board, you must complete this procedure before installing the new system board.

To install the management card, complete the following steps.

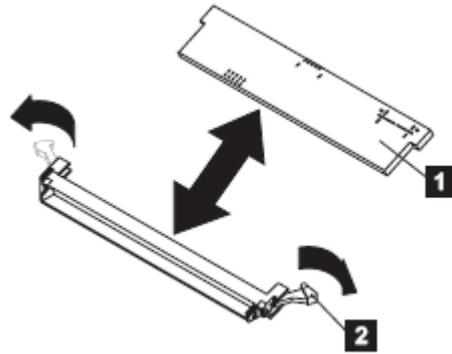

Figure 4-12. Installing the management card

1. Read the documentation that comes with the management card, if you ordered a replacement card.
2. Locate the connector on the currently installed system board into which the management card will be installed. See “*System-board connectors*” on page 12 for the location.
3. Touch the static-protective package that contains the management card to any *unpainted* metal surface on the Bull Blade Chassis - Enterprise or any *unpainted* metal surface on any other grounded rack component; then, remove the management card (as shown by **1** in the figure) from its package.
4. Verify that both of the connector retaining clips are in the fully open position.
5. Turn the management card so that the management card aligns correctly with the connector on the system board.
Attention: To avoid breaking the retaining clips (**2**) or damaging the management card connectors, open and close the clips gently.
6. Insert the management card by pressing the management card along the guides into the connector. Make sure that the retaining clips snap into the closed position.
Important: If there is a gap between the management card and the retaining clips, the management card has not been correctly installed. In this case, open the retaining clips and remove the management card. Then reinsert the management card.

7. Install and close the blade server cover. See "Installing and closing the blade server cover" on page 208.

Statement 21



CAUTION:

Hazardous energy is present when the blade server is connected to the power source. Always replace the blade server cover before installing the blade server.

8. Install the blade server into the Bull Blade Chassis - Enterprise. See *Installing the blade server in a Bull Blade Chassis - Enterprise*, on page 204.

Because the system board and chassis assembly has not changed, the firmware initializes the management card VPD using data that the blade server cached. To ensure that you give the initialization enough time to complete, access the management module and wait for the management module to discover the blade server.

Attention: If the management card was not properly installed, the power-on LED blinks rapidly and a communication error is reported to the management module. If this occurs, remove the blade server from the Bull Blade Chassis - Enterprise, as described in *Removing the management card* on page 216. Reseat the management card, then reinstall the blade server in the Bull Blade Chassis - Enterprise.

9. Complete this procedure before installing a new system board. Then, you can install the new system board by performing the following procedure:
 - a. Shut down the operating system, turn off the blade server, and remove the blade server from the Bull Blade Chassis - Enterprise. See *Removing the blade server from a Bull Blade Chassis - Enterprise* on page 203.
 - b. Perform the procedure for replacing the system board to install the new system board. See *Replacing the Tier 2 system-board and chassis assembly* on page 229.

4.4.11 Removing and installing an I/O expansion card

Add an I/O expansion card to the blade server to provide additional connections for communicating on a network.

The blade server supports various types of I/O expansion cards, including Gigabit Ethernet, Fibre Channel, and Myrinet expansion cards.

Verify that any expansion card that you are using is supported by the Escala BL460 blade server. For example, the following expansion cards are not supported by the Escala BL460 blade server:

- Blade SFF Gb Ethernet
- Cisco 1X InfiniBand
- Qlogic iSCSI TOE Expansion Card (LFF)
- Broadcom 1Gb Ethernet (CFFv)
- SAS 3Gb Expansion Card (CFFv)
- Emulex 4Gb Fibre Channel Expansion Card (CFFv)
- Qlogic 4Gb SFF Fibre Channel Expansion card (CFFv)

4.4.11.1 Removing a CIOv form-factor expansion card

You can remove a CIOv form-factor expansion card from the 1Xe connector.

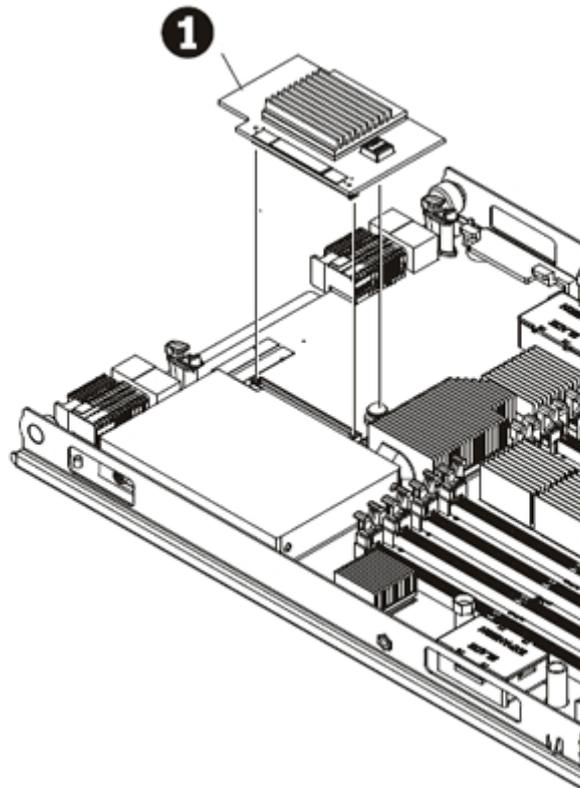

Figure 4-13. Removing a CIOv form factor expansion card from the 1Xe connector

1. Read "Safety" on page vii and the "Installation guidelines" on page 201.
2. Shut down the operating system, turn off the blade server, and remove the blade server from the Bull Blade Chassis - Enterprise. See "Removing the blade server from a Bull Blade Chassis - Enterprise" on page 203.
3. Carefully lay the blade server on a flat, static-protective surface, with the cover side up.
4. Open and remove the blade server cover. See "Removing the blade server cover" on page 206.
5. Lift the expansion card **1** up away from the 1Xe connector and out of the blade server.
6. If you are instructed to return the expansion card, follow all packaging instructions, and use any packaging materials for shipping that are supplied to you.

4.4.11.2 Installing a CIOv form-factor expansion card

Install a CIOv form-factor expansion card on the 1Xe connector to expand the I/O capabilities of the blade server.

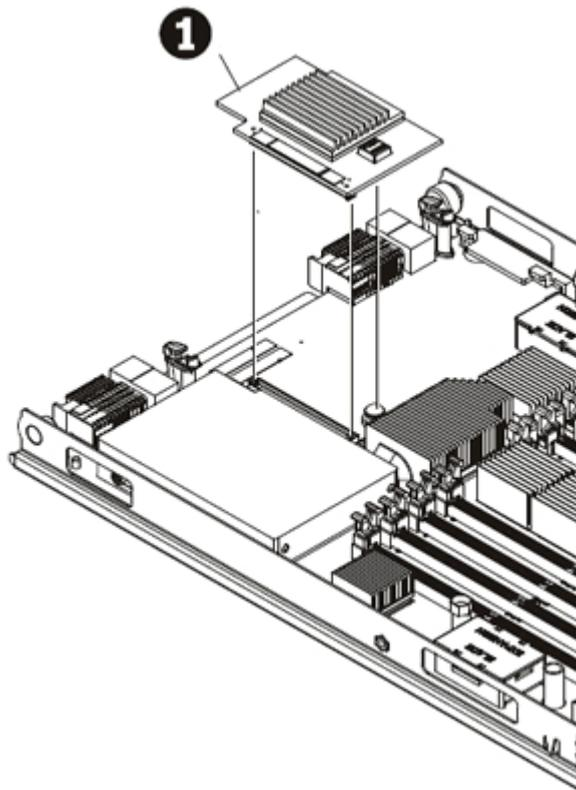

Figure 4-14. Installing a CIOv form-factor expansion card

Perform the following procedure to install a small-form-factor expansion card.

1. Read "Safety" on page *vii* and the "Installation guidelines" on page 201.
2. Shut down the operating system, turn off the blade server, and remove the blade server from the Bull Blade Chassis - Enterprise. See "Removing the blade server from a Bull Blade Chassis - Enterprise" on page 203.
3. Carefully lay the blade server on a flat, static-protective surface, with the cover side up.
4. Open and remove the blade server cover. See "Removing the blade server cover" on page 206.
5. Touch the static-protective package that contains the part to any unpainted metal surface on the Bull Blade Chassis - Enterprise or any unpainted metal surface on any other grounded rack component; then remove the part from its package.
6. Orient the expansion card **1** over the system board.
7. Lower the card to the system board, aligning the connectors on the card with the 1Xe connector on the system board.
8. Install and close the blade server cover. See "Installing and closing the blade server cover" on page 208.

Statement 21



CAUTION:

Hazardous energy is present when the blade server is connected to the power source. Always replace the blade server cover before installing the blade server.

9. Install the blade server into the Bull Blade Chassis - Enterprise unit. See "Installing the blade server in a Bull Blade Chassis - Enterprise" on page 204.
10. Use the documentation that comes with the expansion card to install device drivers and to perform any configuration that the expansion card requires.

4.4.11.3 Removing a combination-form-factor expansion card

Complete this procedure to remove a combination-form-factor expansion card.

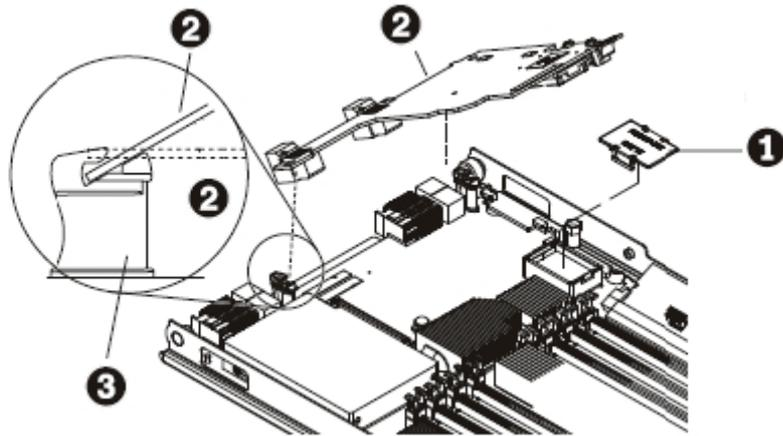

Figure 4-15. Removing a combination-form-factor expansion card

1. Read "Safety" on page vii and the "Installation guidelines" on page 201.
2. Shut down the operating system, turn off the blade server, and remove the blade server from the Bull Blade Chassis - Enterprise. See "Removing the blade server from a Bull Blade Chassis - Enterprise" on page 203.
3. Open and remove the blade server cover. See "Removing the blade server cover" on page 206.
4. Remove the horizontal (CFFh) CFFe expansion card **2**.
 - b. Pull up on the camming lever to disengage the card from the connector.
 - c. Gently pivot the card out of the expansion card connector.
 - d. Slide the card out of the raided expansion card standoff **3** on the system board and lift the card out of the blade server.
 - e. Optional: Reattach the plastic cover **1** for the PCI-Express connector, if it is available.
5. If you are instructed to return the expansion card, follow all packaging instructions, and use any packaging materials for shipping that are supplied to you.

4.4.11.4 Installing a combination-form-factor expansion card

Install a combination-form-factor expansion card to expand the I/O capabilities of the blade server.

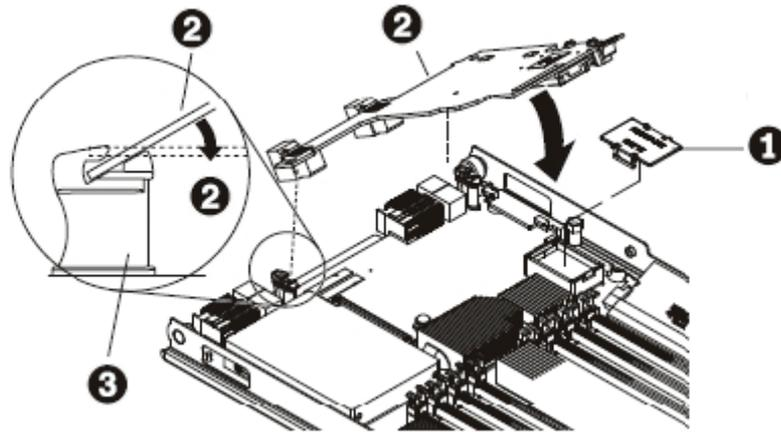

Figure 4-16. Installing a combination-form-factor expansion card

Perform the following procedure to install a combination-form-factor expansion card:

1. Read "Safety" on page vii and the "Installation guidelines" on page 201.
2. Shut down the operating system, turn off the blade server, and remove the blade server from the Bull Blade Chassis - Enterprise. See "Removing the blade server from a Bull Blade Chassis - Enterprise" on page 203.
3. Carefully lay the blade server on a flat, static-protective surface, with the cover side up.
4. Open and remove the blade server cover. See "Removing the blade server cover" on page 206.
5. Remove the plastic cover for the PCI-Express connector **1**.
6. Touch the static-protective package that contains the part to any unpainted metal surface on the Bull Blade Chassis - Enterprise unit or any unpainted metal surface on any other grounded rack component; then, remove the part from its package.
7. Install the expansion card **2**.
 - a. Slide the card into the expansion card standoff **3** on the system board.
 - b. Gently pivot the card down and attach it to the high speed PCIe connector.

8. Install and close the blade server cover. See "*Installing and closing the blade server cover*" on page 208.

Statement 21



CAUTION:

Hazardous energy is present when the blade server is connected to the power source. Always replace the blade server cover before installing the blade server.

9. Install the blade server into the Bull Blade Chassis - Enterprise unit. See "*Installing the blade server in a Bull Blade Chassis - Enterprise*" on page 204.
10. Use the documentation that comes with the expansion card to install device drivers and to perform any configuration that the expansion card requires.

4.4.12 Removing the battery

You can remove and replace the battery.

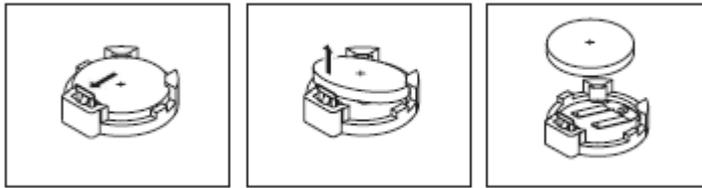

Figure 4-17. Removing the battery

Perform the following procedure to remove the battery.

1. Read "*Safety*" on page vii and the "*Installation guidelines*" on page 201.
2. Shut down the operating system, turn off the blade server, and remove the blade server from the Bull Blade Chassis - Enterprise. See "*Removing the blade server from a Bull Blade Chassis - Enterprise*" on page 203.
3. Carefully lay the blade server on a flat, static-protective surface, with the cover side up.
4. Open and remove the blade server cover. See "*Removing the blade server cover*" on page 206.
5. Locate the battery on the system board. See "*System-board connectors*" on page 12 for the location of the battery connector.

6. Use your finger to press down on one side of the battery; then, slide the battery out from its socket. The spring mechanism will push the battery out toward you as you slide it from the socket.

Note You might need to lift the battery clip slightly with your fingernail to make it easier to slide the battery.

7. Use your thumb and index finger to pull the battery from under the battery clip.

Note After you remove the battery, press gently on the clip to make sure that the battery clip is touching the base of the battery socket.

4.4.13 Installing the battery

You can install the battery.

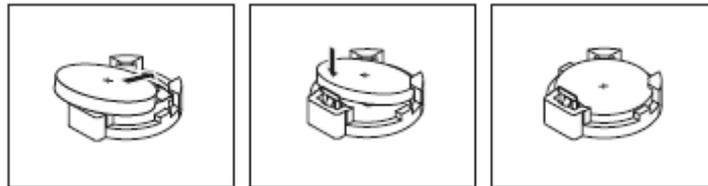

Figure 4-18. Installing the battery

The following notes describe information that you must consider when replacing the battery in the blade server.

- When replacing the battery, you must replace it with a lithium battery of the same type from the same manufacturer.
- After you replace the battery:
 - a. Set the time and date.
 - b. Set the Network IP addresses (for blade servers that start up from a network).
 - c. Reconfigure any other blade server settings.

- To avoid possible danger, read and follow the following safety statement.

Statement 2:



CAUTION:

When replacing the lithium battery, use only a battery recommended by the manufacturer. If your system has a module containing a lithium battery, replace it only with the same module type made by the same manufacturer. The battery contains lithium and can explode if not properly used, handled, or disposed of.

Do not:

- Throw or immerse into water
- Heat to more than 100°C (212°F)
- Repair or disassemble

Dispose of the battery as required by local ordinances or regulations.

Perform the following procedure to install the battery.

1. Follow any special handling and installation instructions that come with the battery.
2. Tilt the battery so that you can insert it into the socket, under the battery clip. Make sure that the side with the positive (+) symbol is facing up.
3. As you slide it under the battery clip, press the battery down into the socket.
4. Install and close the blade server cover. See *“Installing and closing the blade server cover”* on page 208.

Statement 21



CAUTION:

Hazardous energy is present when the blade server is connected to the power source. Always replace the blade server cover before installing the blade server.

5. Install the blade server into the Bull Blade Chassis - Enterprise. See *“Installing the blade server in a Bull Blade Chassis - Enterprise”* on page 204.
6. Turn on the blade server and reset the system date and time through the operating system that you installed. For additional information, see your operating-system documentation.

7. Make sure that the boot list is correct using the management module Web interface. See the management module documentation for more information) or the SMS Utility. See "Using the SMS utility" on page 263 for more information.

4.4.14 Removing the disk drive tray

You can remove the hard disk drive tray.

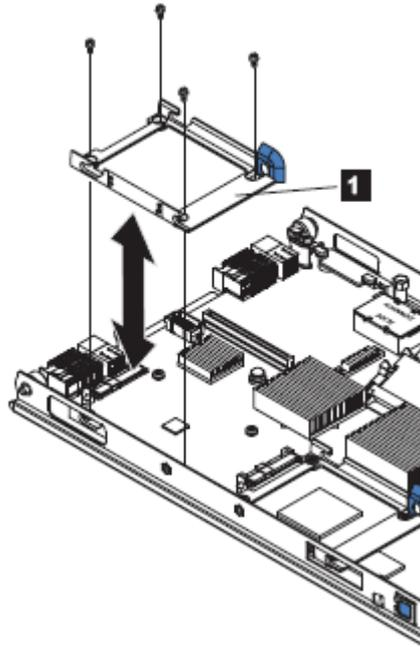

Figure 4-19. Removing the hard disk drive tray

Perform the following procedure to remove the hard disk drive tray.

1. Read "Safety" on page vii and the "Installation guidelines" on page 201.
2. Shut down the operating system, turn off the blade server, and remove the blade server from the Bull Blade Chassis - Enterprise. See "Removing the blade server from a Bull Blade Chassis - Enterprise" on page 203.
3. Carefully lay the blade server on a flat, static-protective surface, with the cover side up.
4. Open and remove the blade server cover. See "Removing the blade server cover", on page 206.
5. Remove the hard disk drive if one is installed. See "Removing a drive" on page 211.
6. Remove the four screws that secure the drive tray to the system board and remove the drive tray.

Save the screws that secure the tray to the system board. Store the screws in a safe place.

4.4.15 Installing the hard disk drive tray

You can install the hard disk drive tray.

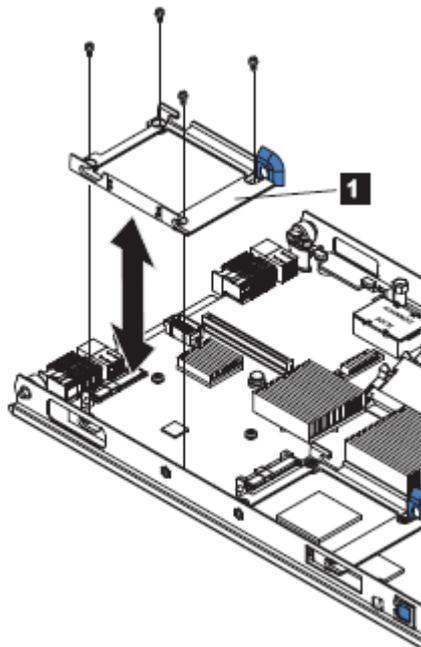

Figure 4-20. Installing the hard disk drive tray

Perform the following procedure to install the hard disk drive tray.

1. Place the drive tray into position on the system board and install the four screws to secure it.
2. Install the hard disk drive that was removed from the drive tray. See *"Installing a drive"* on page 212 for instructions.
3. Install and close the blade server cover. See *"Installing and closing the blade server cover"* on page 208.

Statement 21



CAUTION:

Hazardous energy is present when the blade server is connected to the power source. Always replace the blade server cover before installing the blade server.

4. Install the blade server into the Bull Blade Chassis - Enterprise. See *"Installing the blade server in a Bull Blade Chassis - Enterprise"* on page 204.

4.5 Replacing the Tier 2 system-board and chassis assembly

You can install this Tier 2 CRU yourself or request to install it, at no additional charge, under the type of warranty service that is designated for the blade server. Replace the system board and chassis assembly. When replacing the system board, you will replace the system board, blade base (chassis), microprocessors, and heat sinks as one assembly. After replacement, you must either update the system with the latest firmware or restore the pre-existing firmware that the customer provides on a diskette or CD image.

Note See “*System-board layouts*” on page 12 for more information on the locations of the connectors and LEDs on the system board.

Perform the following procedure to replace the system-board and chassis assembly.

1. Read “*Safety*” on page vii and the “*Installation guidelines*” on page 201.
2. Shut down the operating system, turn off the blade server, and remove the blade server from the Bull Blade Chassis - Enterprise. See “*Removing the blade server from a Bull Blade Chassis - Enterprise*” on page 203.
3. Carefully lay the blade server on a flat, static-protective surface, with the cover side up.
4. Open and remove the blade server cover. See “*Removing the blade server cover*”, on page 206.
5. Remove the blade server bezel assembly. See “*Removing the bezel assembly*” on page 209.
6. Remove any of the installed components listed below from the system board; then, place them on a non-conductive surface or install them on the new system-board and chassis assembly.
 - I/O expansion card. See “*Removing and installing an I/O expansion card*” on page 219.
 - Hard disk drives. See “*Removing a drive*” on page 211.
 - DIMMs. See “*Removing a memory module*” on page 213.
 - Management card. See “*Removing the management card*” on page 216.
 - Battery. See “*Removing the battery*” on page 224.
7. Touch the static-protective package that contains the system-board and chassis assembly to any *unpainted* metal surface on the Bull Blade Chassis - Enterprise or any *unpainted* metal surface on any other grounded rack component; then, remove the assembly from its package.
8. Install any of the components listed below that were removed from the old system-board and chassis assembly.
 - I/O expansion card. See “*Removing and installing an I/O expansion card*” on page 219.

- Hard disk drives. See *"Installing a drive"* on page 212.
 - DIMMs. See *"Installing a memory module"* on page 214.
 - Management card. See *"Installing the management card"* on page 217.
 - Battery. See *"Installing the battery"* on page 225.
9. Install the bezel assembly. See *"Installing the bezel assembly"* on page 210 for instructions.
 10. Install and close the blade server cover. See *"Installing and closing the blade server cover"* on page 208.

Statement 21



CAUTION:

Hazardous energy is present when the blade server is connected to the power source. Always replace the blade server cover before installing the blade server.

11. Write the machine type, model number, and serial number of the blade server on the repair identification (RID) tag that comes with the replacement system-board and chassis assembly. This information is on the identification label that is behind the control-panel door on the front of the blade server.



Important:

Completing the information on the RID tag ensures future entitlement for service.

12. Place the RID tag on the bottom of the blade server chassis.
13. Install the blade server into the Bull Blade Chassis - Enterprise. See *"Installing the blade server in a Bull Blade Chassis - Enterprise"* on page 204.
14. Turn on the blade server and press the keyboard/video select button to switch control of the keyboard and video to the blade server.
15. Reset the system date and time through the operating system that you installed.

For additional information, see the documentation for your operating system.

Chapter 5. Configuring

Update the firmware and use the management module and the system management services (SMS) to configure the Escala BL460 blade server.

5.1 Updating the firmware

Bull periodically makes firmware updates available for you to install on the blade server, the management module, or expansion cards in the blade server.



Important:

To avoid problems and to maintain proper system performance, always verify that the blade server BIOS, service processor, and diagnostic firmware levels are consistent for all blade servers within the Bull Blade Chassis - Enterprise. See “*Verifying the system firmware levels*” on page 187 for more information.

Plan to use a method of applying blade server firmware updates other than the management module. The Escala BL460 blade server enhanced BMC has a larger firmware image that makes it impractical to download and install over the RS-485 bus of the management module. Therefore, a firmware update for the blade server is not supported from the management module.

You can still use the other methods of performing firmware updates for the blade server:

- In-band operating system capabilities, such as the **update_flash** command for Linux and AIX
- The firmware update function of AIX in-band diagnostics
- The firmware update function of the stand-alone *Diagnostics CD*



Important

Before the installation of the new firmware to the Temporary side begins, the contents of the Temporary side are copied into the Permanent side.

After the firmware installation begins, the previous level of firmware on the Permanent side is no longer available.

Use the following procedure to install updated firmware.

1. Start the TEMP image, as described in “*Starting the TEMP image*” on page 186.
2. Download the Escala BL460 firmware.
 - a. Go to the Bull Support site at <http://www.bull.com/support/> to download the updates.
 - b. Select your product, type, model, and operating system, and then click **Go**.
 - c. Click the **Download** tab, if necessary, for device driver and firmware updates.

- d. Download the firmware to the /tmp/fwupdate directory.
3. Log on to the AIX or Linux system as root, or log to the Virtual I/O Server/IVM alpha partition as padmin.
4. Type `ls /tmp/fwupdate` to identify the name of the firmware.
The result of the command lists any firmware updates that you downloaded to the directory, such as the following update, for example: `01EA3xx_yyy_zzz`
5. Install the firmware update with one of the following methods:
 - Install the firmware with the in-band diagnostics of your AIX system, as described in *Using the AIX diagnostics to install the server firmware update through AIX*
 - Install the firmware with the **update_flash** command on AIX:

```
cd /tmp/fwupdate
/usr/lpp/diagnostics/bin/update_flash -f 01EA3xx_yyy_zzz
```
 - Install the firmware with the **update_flash** command on Linux:

```
cd /tmp/fwupdate
/usr/sbin/update_flash -f 01EA3xx_yyy_zzz
```

 Reference codes CA2799FD and CA2799FF are displayed alternately on the control panel during the server firmware installation process. The system automatically powers off and on when the installation is complete.
6. Verify that the update installed correctly, as described in *“Verifying the system firmware levels”* on page 187.
7. Optional: After testing the updated server, you might decide to install the firmware update permanently, as described in *“Committing the TEMP system firmware image”* on page 188.
You can also install an update permanently on either AIX or Linux, as described in:
 - Using AIX commands to install a firmware update permanently
 - Using Linux commands to install a firmware update permanently

5.2 Configuring the blade server

While the firmware is running POST and before the operating system starts, a POST menu with POST indicators is displayed. The POST indicators are the words *Memory*, *Keyboard*, *Network*, *SCSI*, and *Speaker* that are displayed as each component is tested. You can then select configuration utilities from the POST menu.

- **System management services (SMS)**
Use the system management services (SMS) utility to view information about your system or partition and to perform tasks such as setting up remote IPL, changing SCSI device (SCSD) settings, and selecting boot options. The SMS utility can be used for AIX or Linux partitions. See “Using the SMS utility” for more information.
- **Default boot list**
Use this utility to initiate a system boot in service mode through the default service mode boot list. This mode attempts to boot from the first device of each type that is found in the list.
Note: This is the preferred method of starting the stand-alone AIX diagnostics from CD.
- **Stored boot list**
Use this utility to initiate a system boot in service mode, using the customized service mode boot list that was set up by AIX when AIX was first booted, or manually using the AIX service aids.
- **Open firmware prompt**
This utility is for advanced users of the IEEE 1275 specifications only.
- **Management module**
Use the management module to change the boot list, determine which firmware image to boot, and perform other configuration tasks.

5.3 Using the SMS utility

Use the System Management Services (SMS) utility to perform a variety of configuration tasks on the Escala BL460 blade server.

5.3.1 Starting the SMS utility

Start the SMS utility to configure the blade server.

1. Turn on or restart the blade server, and establish a SOL session with it. See the *Management Module Command-Line Interface Reference Guide* or the *Serial-Over-LAN Setup Guide* for more information.
2. When the POST menu and indicators are displayed, press the 1 key after the word Keyboard is displayed and before the word Speaker is displayed.
3. Follow the instructions on the screen.

5.3.2 SMS utility menu choices

Select SMS tasks from the SMS utility main menu. Choices on the SMS utility main menu depend on the version of the firmware in the blade server. Some menu choices might differ slightly from these descriptions.

- **Select Language**
Select this choice to change the language that is used to display the SMS menus.
- **Setup Remote IPL (Initial Program Load)**
Select this choice to enable and set up the remote startup capability of the blade server or partition.
- **Change SCSI Settings**
Select this choice to view and change the addresses of the SCSI controllers that are attached to the blade server.
- **Select Console**
Select this choice to select the console on which the SMS menus are displayed.
- **Select Boot Options**
Select this choice to view and set various options regarding the installation devices and boot devices.

Note: If a device that you are trying to select (such as a USB CD drive in the Blade media tray) is not displayed in the **Select Device Type** menu, select **List all Devices** and select the device from that menu.

5.4 Creating a CE login

If the blade server is running an AIX operating system, you can create a customer engineer (CE) login to perform operating system commands that are required to service the system without being logged in as a root user.

The CE login must have a role of Run Diagnostics and be a primary group of System. This enables the CE login to perform the following tasks:

- Run the diagnostics, including the service aids, certify, and format.
- Run all the operating-system commands that are run by system group users.
- Configure and de-configure devices that are not in use.

In addition, this login can have Shutdown Group enabled to allow use of the Update System Microcode service aid and the shutdown and reboot operations.

The recommended CE login user name is qserv.

5.5 Configuring the Gigabit Ethernet controllers

Two Ethernet controllers are integrated on the blade server system board. You must install a device driver to enable the blade server operating system to address the Ethernet controllers.

Each controller provides a 1000 Mbps full-duplex interface for connecting to one of the Ethernet-compatible I/O modules in I/O-module bays 1 and 2, which enables simultaneous transmission and reception of data on the Ethernet local area network (LAN).

The routing from an Ethernet controller to an I/O-module bay varies according to the blade server type, the Bull Blade Chassis - Enterprise, and the operating system that is installed. For example, each Ethernet controller on the Escala BL460 blade server system board is routed to a different I/O module in I/O module bay 1 or module bay 2 of the Bull Blade Chassis - Enterprise.

See "*Blade server Ethernet controller enumeration*" on page 236 for information about how to determine the routing from an Ethernet controller to an I/O-module bay for the blade server.

Note Other types of blade servers in the same Bull Blade Chassis - Enterprise might have different Ethernet controller routing. See the documentation for information.

You do not have to configure controllers for the blade server operating system. However, you must install a device driver for the blade server operating system to address the Ethernet controllers. For device drivers and information about configuring Ethernet controllers, see the Broadcom NetXtreme Gigabit Ethernet Software CD that comes with the blade server.

The Ethernet controllers in your blade server support failover, which provides automatic redundancy for the Ethernet controllers. Failover capabilities vary per Bull Blade Chassis - Enterprise.

Without failover, only one Ethernet controller can be connected from each server to each virtual LAN or subnet. With failover, you can configure more than one Ethernet controller from each server to attach to the same virtual LAN or subnet. Either one of the integrated Ethernet controllers can be configured as the primary Ethernet controller. If you have configured the controllers for failover and the primary link fails, the secondary controller takes over. When the primary link is restored, the Ethernet traffic switches back to the primary Ethernet controller. See the operating-system device-driver documentation for information about configuring for failover.



To support failover on the blade server Ethernet controllers, the Ethernet switch modules in the Bull Blade Chassis - Enterprise must have identical configurations.

5.6 Blade server Ethernet controller enumeration

The enumeration of the Ethernet controllers in a blade server is operating-system dependent. You can verify the Ethernet controller designations that a blade server uses through the operating-system settings.

The routing of an Ethernet controller to a particular I/O-module bay depends on the type of blade server. You can verify which Ethernet controller is routed to which I/O-module bay by using the following test:

1. Install only one Ethernet switch module or pass-thru module in I/O-module bay 1.
2. Make sure that the ports on the switch module or pass-thru module are enabled. Click **I/O Module Tasks** → **Admin/Power/Restart** in the management-module Web interface.
3. Enable only one of the Ethernet controllers on the blade server. Note the designation that the blade server operating system has for the controller.
4. Ping an external computer on the network that is connected to the switch module or pass-thru module. If you can ping the external computer, the Ethernet controller that you enabled is associated with the switch module or pass-thru module in I/O-module bay 1. The other Ethernet controller in the blade server is associated with the switch module or pass-thru module in I/O-module bay 2.

If you have installed an I/O expansion card in the blade server, communication from the expansion card should be routed to I/O-module bays 3 and 4, if these bays are supported by your Bull Blade Chassis - Enterprise. You can verify which controller on the card is routed to which I/O-module bay by performing the same test and using a controller on the expansion card and a compatible switch module or pass-thru module in I/O-module bay 3 or 4.

5.7 MAC addresses for host Ethernet adapters

Two integrated Ethernet controllers in the Escala BL460 blade server each provide a Host Ethernet Adapter (HEA) that, in turn, provides virtual logical host Ethernet adapters (LHEAs) to client logical partitions (LPARs). The Virtual I/O Server (VIOS) software uses LHEAs as if they were real physical adapters.

The logical HEAs in the Escala BL460 blade server bypass the need for further bridging from VIOS, because the LHEAs connect directly to the integrated Ethernet controllers in the blade server, and from there to the I/O modules in the Bull Blade Chassis - Enterprise.

The Escala BL460 blade server uses two physical HEA ports and 14 logical HEA ports to share the two integrated physical Ethernet adapters on the blade server. The 14 logical HEA medium access control (MAC) addresses are in the same range as the two integrated Ethernet controllers (eth0 and eth1) and the two associated physical HEA ports on the blade server.

The MAC addresses of the two physical HEAs are displayed in the Chassis management module. The MAC address of the first integrated Ethernet controller (eth0) is listed on a label on the blade server. The label also lists the last MAC address. The following table shows the relative addressing scheme.

Node	Name in management module	Relation to the MAC that is listed on the Escala BL460 blade server label	Example
Integrated Ethernet controller eth0		Same as first MAC address	00:1A:64:44:0e:c4
Integrated Ethernet controller eth1		MAC + 1	00:1A:64:44:0e:c5
HEA port 0	MAC address 1	MAC + 2	00:1A:64:44:0e:c6
HEA port 1	MAC address 2	MAC + 3	00:1A:64:44:0e:c7
Logical HEA ports		MAC +4 to MAC +16	00:1A:64:44:0ec8 to 00:1A:64:44:0ed5
Logical HEA port		MAC +17 Same as last MAC address on the label	00:1A:64:44:0ec8 to 00:1A:64:44:0ed5

Table 5-1. MAC addressing scheme for physical and logical host Ethernet adapters

For more information about planning, deploying, and managing the use of host Ethernet adapters, see the *Configuring* section of the *PowerVM Information Roadmap*.

5.8 Updating IBM System Director

If you plan to use IBM System Director to manage the blade server, you must check for the latest applicable IBM System Director updates and interim fixes.

To install the IBM System Director updates and any other applicable updates and interim fixes, complete the following steps.

1. Check for the latest version of IBM System Director.
2. Install IBM System Director.
3. Download and install any applicable updates or interim fixes for the blade server.

Appendix A. Getting help and technical assistance

If you need help, service, or technical assistance or just more information about our products, Bull provides a wide variety of sources to assist you. This appendix indicates where to go for additional information about Bull and Bull products, what to do if you experience a problem with your Bull Blade system, and who to call for service if necessary.

Before you call

Before you call, make sure that you have taken these steps to try to solve the problem yourself:

- Check all cables to make sure that they are connected.
- Check the power switches to make sure that the system is turned on.
- Use the troubleshooting information in your system documentation, and use the diagnostic tools that come with your system.
- Go to <http://www.bull.com/support> and check for information to help you solve the problem.

You can solve many problems without outside assistance by following the troubleshooting procedures that are provided in your system and software documentation. Most systems, operating systems, and programs come with information that contains troubleshooting procedures and explanations of error messages and error codes. If you suspect a software problem, refer to the appropriate software documentation.

If you have not been able to solve the problem yourself, contact your Bull Support Representative.

Using the documentation

Information about your Bull Blade system and pre-installed software, if any, is available in the documentation that comes with your system. The documentation can include printed documents, online documents, readme files, and help files. See the troubleshooting information in your system documentation for instructions for using the diagnostic programs. The troubleshooting information or the diagnostic programs might tell you that you need additional or updated device drivers or other software. Bull maintains pages on the World Wide Web where you can get the latest technical information and download device drivers and updates. To access these pages, go to <http://www.bull.com/support> and select your system.

Appendix B. Notices

Important Notes

Processor speeds indicate the internal clock speed of the microprocessor; other factors also affect application performance.

CD or DVD drive speeds list the variable read rate. Actual speeds vary and are often less than the maximum possible.

When referring to processor storage, real and virtual storage, or channel volume, KB stands for 1024 bytes, MB stands for 1 048 576 bytes, and GB stands for 1 073 741 824 bytes.

When referring to hard disk drive capacity or communications volume, MB stands for 1 000 000 bytes, and GB stands for 1 000 000 000 bytes. Total user-accessible capacity may vary depending on operating environments.

Maximum internal hard disk drive capacities assume the replacement of any standard hard disk drives and population of all hard disk drive bays with the largest currently supported drives available from Bull.

Maximum memory may require replacement of the standard memory with an optional memory module.

Bull makes no representation or warranties regarding non-Bull products and services that are ServerProven®, including but not limited to the implied warranties of merchantability and fitness for a particular purpose. These products are offered and warranted solely by third parties.

Bull makes no representations or warranties with respect to non-Bull products. Support (if any) for the non-Bull products is provided by the third party, not Bull.

Some software may differ from its retail version (if available), and may not include user manuals or all program functionality.

Product recycling and disposal

This unit must be recycled or discarded according to applicable local and national regulations. Bull encourages owners of information technology (IT) equipment to responsibly recycle their equipment when it is no longer needed.



Notice:

This mark applies only to countries within the European Union (EU) and Norway.

This appliance is labeled in accordance with European Directive 2002/96/EC concerning waste electrical and electronic equipment (WEEE). The Directive determines the framework for the return and recycling of used appliances as applicable throughout the European Union. This label is applied to various products to indicate that the product is not to be thrown away, but rather reclaimed upon end of life per this Directive.

注意: このマークは EU 諸国およびノルウェーにおいてのみ適用されます。

この機器には、EU 諸国に対する廃電気電子機器指令 2002/96/EC(WEEE) のラベルが貼られています。この指令は、EU 諸国に適用する使用済み機器の回収とリサイクルの骨子を定めています。このラベルは、使用済みになった時に指令に従って適正な処理をする必要があることを知らせるために種々の製品に貼られています。

Remarque:

Cette marque s'applique uniquement aux pays de l'Union Européenne et à la Norvège.

L'étiquette du système respecte la Directive européenne 2002/96/EC en matière de Déchets des Equipements Electriques et Electroniques (DEEE), qui détermine les dispositions de retour et de recyclage applicables aux systèmes utilisés à travers l'Union européenne. Conformément à la directive, ladite étiquette précise que le produit sur lequel elle est apposée ne doit pas être jeté mais être récupéré en fin de vie.

In accordance with the European WEEE Directive, electrical and electronic equipment (EEE) is to be collected separately and to be reused, recycled, or recovered at end of life. Users of EEE with the WEEE marking per Annex IV of the WEEE Directive, as shown above, must not dispose of end of life EEE as unsorted municipal waste, but use the collection framework available to customers for the return, recycling, and recovery of WEEE. Customer participation is important to minimize any potential effects of EEE on the environment and human health due to the potential presence of hazardous substances in EEE. For proper collection and treatment, contact your local Bull representative.

Electronic emission notices

Federal Communications Commission (FCC) statement

Note: This equipment has been tested and found to comply with the limits for a Class A digital device, pursuant to Part 15 of the FCC Rules. These limits are designed to provide reasonable protection against harmful interference when the equipment is operated in a commercial environment. This equipment generates, uses, and can radiate radio frequency energy and, if not installed and used in accordance with the instruction manual, may cause harmful interference to radio communications. Operation of this equipment in a residential area is likely to cause harmful interference, in which case the user will be required to correct the interference at his own expense.

Properly shielded and grounded cables and connectors must be used in order to meet FCC emission limits. Bull is not responsible for any radio or television interference caused by using other than recommended cables and connectors or by unauthorized changes or modifications to this equipment. Unauthorized changes or modifications could void the user's authority to operate the equipment.

This device complies with Part 15 of the FCC Rules. Operation is subject to the following two conditions: (1) this device may not cause harmful interference, and (2) this device must accept any interference received, including interference that may cause undesired operation.

Industry Canada Class A emission compliance statement

This Class A digital apparatus complies with Canadian ICES-003.

Avis de conformité à la réglementation d'Industrie Canada

Cet appareil numérique de la classe A est conforme à la norme NMB-003 du Canada.

Australia and New Zealand Class A statement

Attention: This is a Class A product. In a domestic environment this product may cause radio interference in which case the user may be required to take adequate measures.

United Kingdom telecommunications safety requirement

Notice to Customers

This apparatus is approved under approval number NS/G/1234/J/100003 for indirect connection to public telecommunication systems in the United Kingdom.

European Union EMC Directive conformance statement

This product is in conformity with the protection requirements of EU Council Directive 89/336/EEC on the approximation of the laws of the Member States relating to electromagnetic compatibility. Bull cannot accept responsibility for any failure to satisfy the protection requirements resulting from a non-recommended modification of the product, including the fitting of non-Bull option cards.

This product has been tested and found to comply with the limits for Class A Information Technology Equipment according to CISPR 22/European Standard EN 55022. The limits for Class A equipment were derived for commercial and industrial environments to provide reasonable protection against interference with licensed communication equipment.

Attention: This is a Class A product. In a domestic environment this product may cause radio interference in which case the user may be required to take adequate measures.

Taiwanese Class A warning statement

警告使用者：
這是甲類的資訊產品，在
居住的環境中使用時，可
能會造成射頻干擾，在這
種情況下，使用者會被要
求採取某些適當的對策。

Chinese Class A warning statement

声 明
此为 A 级产品。在生活环境中，
该产品可能会造成无线电干扰。
在这种情况下，可能需要用户对其
干扰采取切实可行的措施。

Japanese Voluntary Control Council for Interference (VCCI) statement

この装置は、情報処理装置等電波障害自主規制協議会（VCCI）の基準に
基づくクラスA情報技術装置です。この装置を家庭環境で使用すると電波妨害を
引き起こすことがあります。この場合には使用者が適切な対策を講ずるよう要求
されることがあります。

BULL CEDOC
357 AVENUE PATTON
B.P.20845
49008 ANGERS CEDEX 01
FRANCE

REFERENCE
86 A7 81FB 00