

# Hardware Information

Service provider information

ESCALA POWER5



REFERENCE  
86 A1 19EW 00



# ESCALA POWER5

## Hardware Information

Service provider information

### **Hardware**

July 2006

BULL CEDOC  
357 AVENUE PATTON  
B.P.20845  
49008 ANGERS CEDEX 01  
FRANCE

### **REFERENCE**

86 A1 19EW 00

The following copyright notice protects this book under Copyright laws which prohibit such actions as, but not limited to, copying, distributing, modifying, and making derivative works.

Copyright © Bull SAS 1992, 2006

Printed in France

Suggestions and criticisms concerning the form, content, and presentation of this book are invited. A form is provided at the end of this book for this purpose.

To order additional copies of this book or other Bull Technical Publications, you are invited to use the Ordering Form also provided at the end of this book.

### **Trademarks and Acknowledgements**

We acknowledge the right of proprietors of trademarks mentioned in this book.

AIX® is a registered trademark of International Business Machines Corporation, and is being used under licence.

UNIX® is a registered trademark in the United States of America and other countries licensed exclusively through the Open Group.

Linux® is the registered trademark of Linus Torvalds in the U.S. and other countries

# Table of Contents

<b>Service provider information</b> .....	<b>1</b>
Locating and exchanging parts.....	1
Verifying the repair.....	1
Verifying the repair in AIX and Linux.....	1
Verifying the repair from the HMC.....	4
Reference information.....	5
Determining which Processor is the Secondary Service Processor.....	6
Hardware Management Console Maintenance.....	6
Using System Management Services (SMS).....	9
Component and attention LEDs.....	19
Memory plugging for models ESCALA PL 3250R and ESCALA PL 6450R.....	20
Clustering systems using InfiniBand (IB).....	23
Setting expansion unit configuration ID and MTMS value.....	24
Preventive maintenance.....	28
Related information for service provider information.....	28
What's new.....	29
Working with AIX diagnostics.....	30
Printable PDF.....	32
Saving PDF files.....	32
Start of call procedure.....	32
Collect serviceable events in IVM.....	36
Diagnosing a problem on an ESCALA PL 245T/R or a 471/85.....	37
Symptom index.....	40
Detecting problems.....	59
Problem determination procedures.....	59
Problem determination procedure for AIX or Linux servers or partitions.....	314
System unit problem determination.....	332
HMC machine code problems.....	388
Disk-drive-enclosure problem-determination procedures.....	390
Analyzing problems.....	408
Problems with loading and starting the operating system (AIX and Linux).....	408
Problems with noncritical resources.....	556
Intermittent problems.....	557
IPL problems.....	565
Power problems.....	587
Isolating problems.....	639
Isolation procedures.....	640
AIX fast-path problem isolation.....	883
Linux fast-path problem isolation.....	916
HMC isolation procedures.....	919
Using failing item codes.....	920
Symbolic FRUs.....	920
Failing Function Codes (FFCs).....	1122

## Service provider information

## Service provider information

This topic is intended to provide service providers with complete instructions for diagnosing and repairing problems on server hardware.

Before using this information and the products it supports, be sure to read [Safety notices](#).

- **What's new**  
Highlights changes and improvements to the Service provider information.
  - **Printable PDF**  
Provides access to a hardcopy, printable PDF of the service provider information topic.
  - **Start of call procedure**  
Provides a starting point for analyzing problems. You should begin all service actions with this procedure.
  - **Detecting problems**  
Provides information on using various tools and techniques to detect and identify problems.
  - **Analyzing problems**  
Use these instructions and procedures to help you determine the cause of the problem.
  - **Reference codes**  
Provides detailed information on error codes generated by the system.
  - **Isolating problems**  
Provides procedures for determining which part or assembly is failing.
  - **Locating and exchanging parts**  
Provides information for locating and replacing the failing part.
  - **Verifying the repair**  
Provides a guide through the process for verifying and completing the service activity.
  - **Reference information**  
Includes additional information and instructions to aid in servicing the machine.
  - **Related information for service providers**  
Provides links to other information that may be of interest to service providers.
- 

## Locating and exchanging parts

This topic provides service providers with instructions for finding and replacing the failing component.

Before using this information and the products it supports, be sure to read [Safety notices](#).

- **Finding part locations**  
Use this information to help you associate a part name, location code, or address with its physical location.
  - **Part number catalog**  
Use this information to find part numbers of common hardware parts.
  - **Removing and replacing parts**  
Use this information to remove and replace parts.
- 

## Verifying the repair

Use this information to verify hardware operation after making repairs to the system. Choose the operating system that you are working with:

- **Verifying the repair in AIX and Linux**
  - **Verifying the repair from the HMC**
- 

## Verifying the repair in AIX and Linux

Choose from the following:

- If you were sent here after completing a service action on an AIX server or partition, go to [Repair Checkout](#).

- If you were sent here after completing a service action on a Linux server or partition, go to [Verify the installed part](#).

Parent topic: [Verifying the repair](#)

### End of call procedure for servers with Service Focal Point

1. For future reference, record the SRC or symptom and the location code of the FRU you replaced.
2. On the HMC, open Service Focal Point and examine the service action event log for any open service action events.
3. Are there any service action events that are open?  
No  
If the system attention LED is still on, turn off the LED as described in [Activating and deactivating LEDs](#). This completes the repair; return the system to the customer.  
Yes  
Go to step 4.
4. Record the list of open service action events.
5. From the list of serviceable events recorded in step 4, perform step 6 through step 32 for each open service action event.
6. Determine the error class of the serviceable event. Record for future use.
7. Examine the details of the open service action event.

Is the error code associated with this service action event the same as recorded in Step 1322-1?

No

Go to step 27.

Yes

Go to step 11.

8. Examine the FRU list of the service action event. Are there any FRUs listed for the service action event?

No

Go to step 11.

Yes

Go to step 9.

9. Is the FRU list identical (same FRUs, same number of FRUs, and same order of FRUs) to the FRU list of the error code recorded in step 1?

No

Go to step 10.

Yes

Go to step 11.

10. The FRU list is different.

Is the FRU you replaced and recorded in step 1 in the list of FRUs for this service action event?

No

Go to step 32.

**Note:** There are service action events that will remain open when you leave this MAP. Further service actions may be required to complete the repair.

Yes

Go to step 11.

11. Examine the details of this service action event, and record the partitions involved in this service action event for use in a later step.

12. Is the error code associated with this service action event of the form A11-xxx or A01-xxx?

No

Go to step 17.

Yes

Go to step 13.

13. Have you begun a list of "Axx" partitions from prior service action events that you processed in this MAP?

No



- Go to step 14.
- Yes
- Go to step 15.
14. Begin a new list of "Axx" partitions by copying the list of partitions obtained in step 11. Go to step 16.
  15. Add the partition list obtained in step 11 to the existing list of "Axx" partitions obtained from processing previous service action events in this MAP.
  16. Remove all entries in the list of all partitions you recorded in step 11. If you are referred to the list of partitions obtained in step 11 in future steps, the list is empty. Go to step 17.
  17. Select and highlight the service action event from the Error Associated With This Serviceable Event window.
  18. Click Close Event.
  19. Add comments for the serviceable event. Include any unique additional information. Click OK.

The following steps will add or update FRU information.

20. Did you replace, add, or modify a FRU of the open service action event?
  - No
    - Go to step 22.
  - Yes
    - Go to step 21.
21. From the FRU list, select a FRU that you need to update. Double-click on the FRU, and update the FRU information. Go to step 23.
22. Select the No FRU Replaced for this Serviceable Event option.
23. Click OK to close the service action event.
24. Is the list of all partitions you recorded in step 11 empty?
  - No
    - Go to step 25.
  - Yes
    - Go to step 32.
25. Does the list of all partitions you recorded in step 11 contain more than one entry?
  - No
    - Go to step 32.
  - Yes
    - Go to step 26.
26. Is the error class recorded in step 25 AIX?
  - No
    - Go to step 32.
  - Yes
    - Go to step 27.
27. Perform the following steps for each entry in the list of all partitions you recorded in step 11, except the partition you were using to debug the original problem.
28. From the HMC virtual terminal window of a partition in the list of all partitions, type `diag` at the AIX command prompt.
29. When the diagnostic operating instructions are displayed, do the following:
  - a. Press Enter.
  - b. Select the Task Selection option.

**Note:** If the terminal type is not defined, you are prompted to define it before you can proceed.

- c. Select the Log Repair option.
- d. Select the resource associated with the repair action. If the repair action was reseating a cable or adapter, select the resource associated with that repair action. If the resource associated with your repair action is not displayed on the Resource List, select **sysplanar0**.
- e. Click Commit after you have made your selection.
30. Exit from diagnostics in this partition and return to the AIX prompt.
31. Have all the partitions in the list of all partitions you recorded in step 11 been processed?
  - No
    - Go to step 27 to process the next partition in the list you recorded in step 11.
  - Yes
    - Go to step 32.
32. Have all the serviceable events recorded in step 4 been processed?
  - No
    - Go to step 5 and process the next service action event in the list of serviceable events recorded in step 4.

Yes

Go to step 33.

33. While processing all service action events, were you directed to step 14?

No

If the system attention LED is still on, turn off the LED as described in [Activating and deactivating LEDs](#). This completes the repair. Return the system to the customer.

**Note:** If during the processing of the list of open service action events, some service action events remained open, further service actions may be required to complete the repair.

Yes

Go to step 34.

34. Perform the following steps for each entry in the list of "Axx" partitions you began recording in step 14, except the partition you were using to debug the original problem.

35. From the HMC virtual terminal window of a partition in the list of "Axx" partitions, type `diag` at the AIX command prompt.

36. When the diagnostic operating instructions are displayed, do the following:

- a. Press Enter.
- b. Select the Task Selection option.

**Note:** If the terminal type is not defined, you are prompted to define it before you can proceed.

- c. Select the Log Repair option.
- d. Select the resource associated with the repair action. If the repair action was reseating a cable or adapter, select the resource associated with that repair action. If the resource associated with your repair action is not displayed on the Resource List, select `sysplanar0`.
- e. Click Commit after you have made your selection.

37. Exit from diagnostics in this partition and return to the AIX prompt.

38. Have all the partitions in the list of "Axx" partitions you began recording in step 14 been processed?

No

Go to step 34 to process the next partition in the list you recorded in step 14.

Yes

If the system attention LED is still on, turn off the LED as described in [Activating and deactivating LEDs](#). This completes the repair. Return the system to the customer.

**Note:** If during the processing of the list of open service action events, some service action events remained open, further service actions may be required to complete the repair.

## Verifying the repair from the HMC

Perform these procedures to close problem numbers, clear hardware messages, and prepare the server to return to the customer.

Follow this checklist before performing the procedures:

- You return the server to the state that the customer normally uses such as IPL type, IPL mode, and the way the system is configured or partitioned.

**Attention:** Before returning the system to the customer, remove the system from service mode. If the system is left in service mode, it automatically places a call for service every two hours.

- While you were performing the problem analysis on the original serviceable event, other serviceable-event numbers might have been opened. Close all serviceable events that were opened as a result of your service activity.
- Server verification has been performed and there are no problems that require additional service actions.
- If the repair was done using the HMC online repair procedures, ensure that the original serviceable event is now closed.

1. Is an HMC used to manage the server that you are servicing?
  - ◆ No: Return to the [Verifying the repair](#). This ends the procedure.
  - ◆ Yes: Continue with step 2.
2. Are you closing a service event that was a repair on the HMC personal computer?
  - ◆ No: Go to step 4.
  - ◆ Yes: Continue with step 3.
3. Power on the HMC. Did the power-on process complete without errors?
  - ◆ No: Go to the [HMC isolation procedures](#). This ends the procedure.
  - ◆ Yes: Ensure that the HMC can be used to perform server management tasks, and return the HMC to normal operations. This ends the procedure.
4. Log into the HMC as the service representative. If invalid user or invalid password displays, get the correct login information from the system administrator.
  - a. If logged on the System Manager, select Exit from the Console, located on the System Manager window.
  - b. Login to the System Manager with the following: User identification service Password service mode
5. View Serviceable Event Details.

**Note:** Only the events that match all of the criteria you specify are shown.

- a. In the Navigation area, select the **Service Applications** icon.
  - b. In the Navigation area, select the **Service Focal Point** icon.
  - c. In the Contents area, select **Manage Serviceable Events**.
  - d. Designate the set of Serviceable Events you want to view. When you are finished, click OK. The **Service Event Overview** window opens.
6. Close open or delayed events.
    - a. Select the problem to close, on the **Service Event Overview** window.
    - b. Select the menu Selected, located on the menu bar.
    - c. Click **Close Event**.
    - d. Enter your comments in the **Serviceable Event Comments** window, and click **Close Event**.
    - e. Close all events associated with the problem on which you were working.
  7. Did the Service Event Overview window contain the event or events on which you were working?
    - ◆ No: Go to [Detecting problems](#). This ends the procedure.
    - ◆ Yes: Return the HMC to normal operations. This ends the procedure.

**Parent topic:** [Verifying the repair](#)

---

## Reference information

This information is intended to provide service providers with supplemental information for servicing server hardware.

Before using this information and the products it supports, be sure to read [Safety notices](#).

- **Determining which Processor is the Secondary Service Processor**  
Use this procedure to determine which service processor on your system is the secondary service processor.
  - **Working with AIX diagnostics**  
Provides diagnostic information specific to AIX.
  - **Powering on and powering off**  
Provides information for powering on and powering off the system.
  - **Hardware Management Console Maintenance**  
Provides information for servicing the HMC.
  - **Using System Management Services (SMS)**  
Provides information for using the System Management Services.
  - **Component and attention LEDs**  
Provides information about component and attention LEDs.
  - **Memory plugging for models ESCALA PL 3250R and ESCALA PL 6450R**  
Provides guidelines for installing memory in a model ESCALA PL 3250R or ESCALA PL 6450R system.
  - **Clustering systems using InfiniBand (IB)**  
server hardware supports clustering through InfiniBand (IB) Host Channel Adapters (HSAs) and switches. The guide to [Clustering systems using InfiniBand \(IB\) hardware](#), provides planning and installing information to help guide you through the process of installing a cluster fabric that incorporates these switches. Also in this guide, there is information about how to manage and service an InfiniBand (IB) cluster.
  - **Setting expansion unit configuration ID and MTMS value**  
Provides instructions for setting important system values.
  - **Preventive maintenance**  
Provides instructions for system maintenance. Annually check and replace system filters as needed.
  - **Forms**  
Provides various forms that may be needed during a service activity.
- 

## Determining which Processor is the Secondary Service Processor

Use this procedure to determine which service processor on your system is the secondary service processor.

1. Locate the HMC1 and HMC2 port pairs for service processor zero and for service processor one. (See [Finding part locations](#) for your specific model.)
2. Is only one service processor with cables attached to its HMC ports?
  - ◆ **No:** Continue to the next step.
  - ◆ **Yes:** The secondary service processor is the service processor with no cables attached to the HMC ports. **This ends the procedure.**
3. Use the HMC to access Advanced System Management Interface (ASMI) to determine which service processor is the secondary service processor. First, verify ASMI connectivity by logging onto ASMI. Then pull all HMC cables from HMC ports for service processor zero (leaving service processor one HMC cables attached).

Log onto ASMI again. Were you successfully able to log onto ASMI?

- ◆ **No:** The service processor with HMC cables still attached is the secondary service processor. Reattach the HMC cable(s) to service processor zero. **This ends the procedure.**
- ◆ **Yes:** The cables just removed identify the secondary service processor. Reattach the HMC cables to the secondary service processor. **This ends the procedure.**

Parent topic: [Reference information](#)

---

## Hardware Management Console Maintenance

Provides information for servicing the HMC.

The HMC connects to one or more managed systems to perform various functions. The HMC's main functions include the following:

- Providing a console for system administrators and service representatives to manage server hardware.
- Creating and maintaining a multiple partitioned environment on a managed system.
- Detecting, reporting, and storing changes in hardware conditions.
- Acting as a service focal point for service representatives to determine an appropriate service strategy.
- Displaying operating system session terminals for each partition.

The hardware management console (HMC) system is delivered with its machine code preinstalled on the disk drive. After the system is installed and connected to a managed system, system management tasks can begin.

The HMC machine code does not have provisions for loading or running additional applications that are not related to hardware management or service. All the tasks you need to maintain the managed system, the underlying operating system, and the HMC's machine code are available by using the HMC's management interface.

**Parent topic:** [Reference information](#)

### **Managed system operation**

The HMC's graphical user interface provides the functions needed to create and maintain a partitioned environment on a managed system. Using the interface allows for direct manipulation of HMC-defined objects and increased information regarding detected changes in hardware conditions.

The managed system can be run as a partitioned system, sometimes referred to as *logically partitioned* (LPAR). This means that the managed system can run multiple operating systems simultaneously. The system can also run as a large single partition, which is known as the *manufacturing default configuration* when the system is delivered. If the system has been partitioned, then a the single partition that uses all the system resources is referred to as a *full system partition*.

Partitioning provides users with the ability to divide a single managed system into several systems. Each of these systems, running in a partition, is capable of running applications in multiple, independent environments simultaneously. Logical partitioning makes it possible for a user to run a single application using different sets of data on separate partitions, as if that application were running independently on separate physical systems. By creating partitions, for example, a company can test its programs in one partition while developing the same program in another, at the same time, all using the same system. This "same system" partitioning method is more cost-effective, potentially eliminating the need for a separate test system.

The full system partition is no different from the traditional way of using a system. The single server uses all of its resources as one system.

### **HMC system diagnostics**

Your HMC system also provides a set of diagnostic procedures that should be followed when troubleshooting HMC problems. Select [HMC diagnostic overview](#) to access the HMC diagnostic topic.

## Powering On and Off

During the process of powering on, the HMC checks to see which managed systems are available and communicating with the console. To ensure that each managed system is available before you power on the HMC, managed systems must be in "standby mode" or actively operating. Standby mode is indicated by the OK shown in the operator panel after the managed system has the power connected and the initial tests are complete.

**Note:** If the managed system is in an emergency power off (EPOW) condition, the managed system must be brought to "standby mode" before the HMC can be used to power on the system.

To power on the HMC, do the following:

1. Press the Power button once to turn on the power.
2. When the system has finished the power-on self-test (POST), log in to the HMC by using your service representative name and password.

## Power off the HMC

To power off the HMC, do the following:

1. Log in to the HMC and select Power Off.
2. The HMC shuts down any applications that are running, and then turns off the HMC.

## Power-On Self-Test

After power is turned on and before the operating system is loaded, the system does a power-on self-test (POST). This test performs checks to ensure that the hardware is functioning correctly before the operating system is loaded. During the POST, codes indicating the progress of the POST might appear on the display. After the POST is complete, the HMC operating machine code loads and a login prompt appears.

## Specifications and system unit locations

For your HMC's system specifications and system unit locations, go to [Hardware Management Console \(HMC\) parts](#), and then go to the appropriate Hardware Maintenance Manual (HMM).

## HMC external AC power cable

To avoid electrical shock, a power cable with a grounded attachment plug is provided. Use only properly grounded outlets.

Power cables used in the United States and Canada are listed by Underwriter's Laboratories (UL) and certified by the Canadian Standards Association (CSA). These power cords consist of the following:

- Electrical cables, type ST
- Attachment plugs complying with National Electrical Manufacturers Association (NEMA) L6-30P
- Appliance couplers complying with International Electrotechnical Commission (IEC) Standard 320, Sheet C13 and C14

Power cables used in other countries consist of the following:

- Electrical cables, type HD21 or HD22
- Attachment plugs approved by the appropriate testing organization for the specific countries where they are used
- Appliance couplers complying with the International Electrotechnical Commission (IEC) Standard 320, Sheet C13 and C14

---

## Using System Management Services (SMS)

Provides information for using the System Management Services.

Use the system management services menus to view information about your system or partition, and to perform tasks such as setting a password, changing the boot list, and setting the network parameters.

### Notes:

1. If the firmware console is a graphics terminal, you will be asked to enter the password for the service processor's admin user that was set using the Advanced System Management Interface (ASMI).
2. On some of the system management services (or service processor) screens, you will see the term *LPAR*. LPAR is equivalent to the term *logically partitioned server* or *partitioned server*.
3. In a partitioned server, only those devices that are assigned to the partition that is being booted display in the SMS menus. In a partition that uses all the resources in a server, all devices in the system display in the SMS menus.
4. In some of the following example screens, *Un* is used in place of *Ufeature\_code.model.serial number* for legibility.

To start the system management services, do the following:

1. For a server that is connected to an HMC, use the HMC to restart the server or partition.

If the server is not connected to an HMC, stop the system, and then restart the server by pressing the power button on the control panel.

2. For a partitioned server, watch the virtual terminal window on the HMC.

For a full server partition, watch the firmware console.

3. Look for the POST indicators memory, keyboard, network, scsi, speaker, which appear across the bottom of the screen. Press the numeric 1 key after the word keyboard appears, and before the word speaker appears.

After the system management services starts, the following screen displays:

Main Menu

- ```
1  Select Language
2  Setup Remote IPL (Initial Program Load)
3  Change SCSI Settings
4  Select Console
5  Select Boot Options
```

-----  
Navigation keys:

## Service provider information

X = eXit System Management Services

-----  
Type the number of the menu item and press Enter or Select a Navigation key: \_

**Note:** The system management services can also be started using the Service Processor Boot Mode Menu.

On all menus except the Main Menu, there are several navigation keys:

- M Return to the main menu.
  - ESC Return to the previous menu.
  - X Exit the system management services and start the operating system.
- If X is entered, you are asked to confirm your choice to exit the SMS menus and start the operating system.

When there is more than one page of information to display, there are two additional navigation keys:

- N Display the next page of the list.
- P Display the previous page of the list.

**Note:** The lowercase navigation key has the same effect as the uppercase key that is shown on the screen. For example, m or M returns you to the main menu.

On each menu screen, you are given the option of choosing a menu item and pressing Enter (if applicable), or selecting a navigation key.

### Select language

**Note:** Your TTY must support the ISO-8859 character set to properly display languages other than English.

This option allows you to change the language used by the text-based System Management Services menus.

SELECT LANGUAGE

1. English
2. Francais
3. Deutsch
4. Italiano
5. Espanol

-----  
Navigation keys:

M = return to main menu

ESC key = return to previous screen

X = eXit System Management Services



## Service provider information

Type the number of the menu item and press Enter or Select a Navigation key: \_

### Setup remote IPL (Initial Program Load)

This option allows you to enable and set up the remote startup capability of your server or partition. A list of NIC (network interface card) adapters in the server displays first. An example of this screen follows:

**Attention:** In a partitioned server, only those network adapters that have been assigned to the partition being booted display in the IP Parameters menu. In a full system partition, all network adapters in the system are listed in the adapter parameters menu.

```
NIC Adapters
          Device                Slot                Hardware Address
1.  Port 1 - 2 PORT Gigabit Et  Un-P1-T9          00096bff616b
2.  Port 2 - 2 PORT Gigabit Et  Un-P1-T10         00096bff616a
3.  10/100/1000 Base-TX PCI-X   Un-CB1-C03-T1    000295e3814f
```

-----  
Navigation keys:

M = return to main menu

ESC key = return to previous screen                    X = eXit System Management Services

-----  
Type the number of the menu item and press Enter or Select a Navigation key: \_

When an adapter is selected, the Network Parameters menu displays:

```
Network Parameters
Port 1 - 2 PORT Gigabit Et  Un-P1-T9          00096bff616b
1.  IP Parameters
2.  Adapter Parameters
3.  Ping Test
```

-----  
Navigation keys:

M = return to main menu

ESC key = return to previous screen                    X = eXit System Management Services

-----  
Type the number of the menu item and press Enter or Select a Navigation key: \_

Selecting the IP (Internet Protocol) parameters option displays the following menu:

```
IP Parameters
Port 1 - 2 PORT Gigabit Et  Un-P1-T9          00096bff616b
1.  Client IP Address        000.000.000.000
2.  Server IP Address        000.000.000.000
3.  Gateway IP Address       000.000.000.000
4.  Subnet Mask              255.255.255.000
```

-----  
Navigation keys:

M = return to main menu

ESC key = return to previous screen                    X = eXit System Management Services

-----  
Type the number of the menu item and press Enter or Select a Navigation key: \_

To change IP parameters, type the number of the parameters for which you want to change the value. Entering IP parameters on this screen will automatically update the parameters on the ping test screen.

**Attention:** If the client system and the server are on the same subnet, set the gateway IP address to 0.0.0.0.

Selecting Adapter Configuration allows the setting of the network speed, enabling or disabling spanning tree, and setting the protocol as shown in the following example menu:

```
Adapter Configuration
Port 1 - 2 PORT Gigabit Et   Un-P1-T9   00096bff616b
1. Speed, Duplex
2. Spanning Tree Enabled
3. Protocol
```

-----

Navigation keys:

M = return to main menu

ESC key = return to previous screen                      X = eXit System Management Services

-----

Type the number of the menu item and press Enter or Select a Navigation key: \_

Selecting the Speed, Duplex option allows you to set the interface speed at which the card will run and half versus full duplex. The current setting is indicated by "<===".

```
Adapter Configuration
Port 1 - 2 PORT Gigabit Et   Un-P1-T9   00096bff616b

1. auto, auto
2. 10,half
3. 10,full
4. 100,half
5. 100,full
```

-----

Navigation keys:

M = return to main menu

ESC key = return to previous screen                      X = eXit System Management Services

-----

Type the number of the menu item and press Enter or Select a Navigation key: \_

Selecting the Spanning Tree Enabled menu allows you to enable or disable the spanning tree flag. If this flag is enabled (because the network the system is being attached to supports spanning trees), the firmware will impose a waiting period of 60 seconds before the adapter is allowed to communicate with the network. If this flag is disabled, the network adapter will be able to access the network immediately after the system is connected.

The Protocol option allows you to set the appropriate protocol for your network as shown below.

```
Protocol
Port 1 - 2 PORT Gigabit Et   Un-P1-T9   00096bff616b

1. Standard <===
2. IEEE802.3
```

-----

Navigation keys:

M = return to main menu

ESC key = return to previous screen                      X = eXit System Management Services

-----

Type the number of the menu item and press Enter or Select a Navigation key: \_

Select the ping test option from the network parameters menu to test an adapter's network connection to a remote system. After the ping test option is selected, the same series of screens will take you through setting up the IP parameters and the adapter configuration before attempting the ping test.

**Notes:**

1. Once the ping test is initiated, it may take 60 seconds or longer to return a result.
2. If the ping test passes or fails, the firmware will stop and wait for a key to be pressed before continuing.

**Change SCSI settings**

This option allows you to view and change the addresses of the SCSI controllers attached to your system.

SCSI Utilities

1. Hardware Spin Up Delay
2. Change SCSI Id

```
-----  
Navigation keys:  
M = return to main menu  
ESC key = return to previous screen          X = eXit System Management Services  
-----  
Type the number of the menu item and press Enter or Select a Navigation key: _
```

**Select console**

The Select Console utility allows the user to select which console to use to display the SMS menus. This selection is only for the SMS menus and does not affect the display used by the operating system.

Follow the instructions that display on the screen. The firmware automatically returns to the SMS main menu.

**Select boot options**

Use this menu to view and set various options regarding the installation devices and boot devices.

1. Select Install or Boot a Device
2. Select Boot Devices
3. Multiboot Startup

```
-----  
Navigation keys:  
M = return to main menu  
ESC key = return to previous screen          X = eXit System Management Services  
-----  
Type the number of the menu item and press Enter or Select a Navigation key: _
```

**Select Install or Boot Device**

## Service provider information

Allows you to select a device from which to boot or install the operating system. This option is for the current boot only.

### Select Boot Devices

Allows you to set the boot list.

### Multiboot Startup

Toggles the multiboot startup flag, which controls whether the multiboot menu is invoked automatically on startup.

If Select Install or Boot Device is selected, the following menu displays:

```
Select Device Type
1.  Diskette
2.  Tape
3.  CD/DVD
4.  IDE
5.  Hard Drive
6.  Network
7.  None
8.  List All Devices
```

---

#### Navigation keys:

M = return to main menu

ESC key = return to previous screen                      X = eXit System Management Services

---

Type the number of the menu item and press Enter or Select a Navigation key: \_

If a device is selected that is not in the system, a menu with the following message displays:

```
-----
| THE SELECTED DEVICES WERE NOT DETECTED IN THE SYSTEM ! |
Press any key to continue.
```

If Hard Drive is selected, a menu similar to the following displays:

```
Select Hard Drive Type
1.  SCSI
2.  SSA
3.  SAN
4.  None
5.  List All Devices
```

---

#### Navigation keys:

M = return to main menu

ESC key = return to previous screen                      X = eXit System Management Services

---

Type the number of the menu item and press Enter or Select a Navigation key: \_

If SCSI is selected, for example, all of the SCSI adapters that are in the system, or assigned to the partition, are shown on the next screen. Depending on the devices that are installed in your system, a menu similar to the following displays:

```
Version SF220_014
SMS 1.5 (c) Copyright IBM Corp. 2000, 2003 All rights reserved.
```

---

#### Select Media Adapter

```
1.  Un-P1-T14 /pci@80000002000000d/pci@2/pci1069,b166@1/scsi@0
2.  Un-P1-T12 /pci@80000002000000f/pci@2,2/pci1069,b166@1/scsi@0
3.  Un-P1-T13 /pci@80000002000000f/pci@2,2/pci1069,b166@1/scsi@1
4.  List all devices
```

---

#### Navigation keys:

M = return to main menu

ESC key = return to previous screen                      X = eXit System Management Services

## Service provider information

-----  
Type the number of the menu item and press Enter or Select a Navigation key: \_

When an adapter is selected, the next screen displays the devices of the requested type that are attached to that adapter. In the following example, all of the SCSI hardfiles that are attached to the first adapter are listed:

Version SF220\_014  
SMS 1.5 (c) Copyright IBM Corp. 2000, 2003 All rights reserved.

-----  
Select Device  
Device Current Device  
Number Position Name  
1 1 SCSI 73407 MB Harddisk Un-P1-T14 /pci@80000002000000d/pci@2/  
pci1069,b166@1/scsi@0  
-----

-----  
Navigation keys:  
M = return to main menu  
ESC key = return to previous screen X = eXit System Management Services  
-----

Type the number of the menu item and press Enter or Select a Navigation key: \_

The appropriate device can then be selected for this installation or boot.

When a device is selected for installing the operating system, or to boot from, the Select Task menu allows you to get more information about the device, or to boot from that device in normal mode or service mode. The following is an example of this menu.

Select Task  
SCSI 73407 MB Harddisk Un-P1-T14 /pci@80000002000000d/pci@2/pci1069,b166@1/scsi@0  
1. Information  
2. Normal Mode Boot  
3. Service Mode Boot

-----  
Navigation keys:  
M = return to main menu  
ESC key = return to previous screen X = eXit System Management Services  
-----

Type the number of the menu item and press Enter or Select a Navigation key: \_

If either Normal Mode Boot or Service Mode Boot is selected, the next screen will ask, *Are you sure?* If you answer yes, the device will be booted in the appropriate mode. If you answer no, the firmware will return to the Select Task menu.

### Select boot devices

**Attention:** In a partitioned system, only those devices from which an operating system can be booted that are assigned to the partition that is being booted display on the select boot devices menu. In a full system partition, devices from which an operating system can be booted display on the Select Boot Devices menu.

**Note:** To keep the search time for bootable devices down, these menus follow a hierarchy of:

device type -> bus type -> adapter -> devices attached to the adapter

To view all of the potentially bootable devices at one time rather than traversing down the hierarchy with the submenus, go to the "Select Device Type" menu or the "Select Media Type" menu and select the last option, "List All Devices".

The "List All Devices" function may take a long time on a large system with many I/O adapters and devices, such as large disk arrays.

Select this option to view and change the customized boot list, which is the sequence of devices read at startup.

```
Configure Boot Device Order
1.  Select 1st Boot Device
2.  Select 2nd Boot Device
3.  Select 3rd Boot Device
4.  Select 4th Boot Device
5.  Select 5th Boot Device
6.  Display Current Setting
7.  Restore Default Setting
```

-----  
Navigation keys:

M = return to main menu

ESC key = return to previous screen                      X = eXit System Management Services

-----

Type the number of the menu item and press Enter or Select a Navigation key: \_

When any of the options 1-5 is selected, the Select Device Type screen will be displayed, which is similar to the following:

```
Select Device Type
1.  Diskette
2.  Tape
3.  CD/DVD
4.  IDE
5.  Hard Drive
6.  Network
7.  None
8.  List All Devices
```

-----  
Navigation keys:

M = return to main menu

ESC key = return to previous screen                      X = eXit System Management Services

-----

Type the number of the menu item and press Enter or Select a Navigation key: \_

When a device type is selected, such as item 5, a Select Media Type menu is displayed. The following is an example of that menu.

```
Select Media Type
1.  SCSI
2.  SSA
3.  SAN
4.  IDE
5.  ISA
7.  None
8.  List All Devices
```

-----  
Navigation keys:

M = return to main menu

ESC key = return to previous screen                      X = eXit System Management Services

-----

Type the number of the menu item and press Enter or Select a Navigation key: \_

When the media type is selected, all adapters of that type are displayed on the Select Media Adapter menu. The following is an example of that menu for a SCSI media type.

## Service provider information

SMS 1.5 (c) Copyright IBM Corp. 2000, 2003 All rights reserved.

### Select Media Adapter

1. Un-P1-T14 /pci@80000002000000d/pci@2/pci1069,b166@1/scsi@0
2. Un-P1-T12 /pci@80000002000000f/pci@2,2/pci1069,b166@1/scsi@0
3. Un-P1-T13 /pci@80000002000000f/pci@2,2/pci1069,b166@1/scsi@1
4. List all devices

### Navigation keys:

M = return to main menu

ESC key = return to previous screen

X = eXit System Management Services

Type the number of the menu item and press Enter or Select a Navigation key: \_

Each adapter must then be selected individually to see the devices that are attached to it. An example of this menu for the first adapter in the previous example is as follows:

Version SF220\_014

SMS 1.5 (c) Copyright IBM Corp. 2000, 2003 All rights reserved.

| Select Device Number | Device Current Position | Device Name                                                                       |
|----------------------|-------------------------|-----------------------------------------------------------------------------------|
| 1                    | 1                       | SCSI 73407 MB Harddisk Un-P1-T14 /pci@80000002000000d/pci@2/pci1069,b166@1/scsi@0 |

### Navigation keys:

M = return to main menu

ESC key = return to previous screen

X = eXit System Management Services

Type the number of the menu item and press Enter or Select a Navigation key: \_

If there are no devices of the type chosen earlier (on the Select Device Type menu) attached to the adapter that is specified, a message similar to the following displays:

```
| THE SELECTED DEVICES WERE NOT DETECTED IN THE SYSTEM |
| Press any key to continue. |
```

When a device type is selected, the Select Task menu allows you to see detailed information about the device or set the device's location in the boot list as shown below in the example menu. The following is an example of the menu for a hard disk.

### Select Task

SCSI 73407 MB Harddisk Un-P1-T14 /pci@80000002000000d/pci@2/pci1069,b166@1/scsi@0

1. Information
2. Set Boot Sequence: Configure as 1st Boot Device

### Navigation keys:

M = return to main menu

ESC key = return to previous screen

X = eXit System Management Services

Type the number of the menu item and press Enter or Select a Navigation key: \_

Selecting Information displays a menu similar to the following for a hard disk.

Device Information  
/pci@80000002000000d/pci@2/pci1069,b166@1/scsi@1/sd@5,0  
: (Bootable)  
DEVICE : SCSI 73407 MB Harddisk Un-P1-T14 /pci@80000002000000d/pci@2/

### Service provider information

```
pci1069,b166@1/scsi@0
NAME          : sd
DEVICE-TYPE   : block
```

```
Parent Information
IBM,FW-ADAPTER-NAME: Ultra-320
NAME           : scsi
DEVICE-TYPE    : scsi-2
```

```
-----
Navigation keys:
M = return to main menu
ESC key = return to previous screen          X = eXit System Management Services
-----
Type the number of the menu item and press Enter or Select a Navigation key: _
```

The Set Boot Sequence option allows you to set the location of the device in the boot list.

#### Display current settings

This option displays the current setting of the customized boot list. An example of this menu, with one device in the boot list, follows.

```
Current Boot Sequence
1. SCSI 73407 MB Harddisk Un-P1-T14 /pci@800000002000000d/pci@2/pci1069,b166@1/scsi@0
2. None
3. None
4. None
5. None
```

```
-----
Navigation keys:
M = return to main menu
ESC key = return to previous screen          X = eXit System Management Services
-----
Type the number of the menu item and press Enter or Select a Navigation key: _
```

#### Restore default settings

This option restores the boot list to the default boot list. The default boot list will vary depending on the devices that are installed in the system.

The default boot list is as follows:

1. Primary diskette drive (if installed)
2. Optical drive (if installed)
3. Tape drive (if installed)
4. Hard disk drive (if installed)
5. Network adapter



**Multiboot startup**

Multiboot Startup toggles the multiboot startup flag, which controls whether the multiboot menu is invoked automatically on startup.

**Exiting system management services**

After you have finished using the system management services, type x (for exit) to boot your system or partition.

Parent topic: [Reference information](#)

---

## Component and attention LEDs

Provides information about component and attention LEDs.

The component and attention LEDs assist in identifying failing components in your server. If a failing component is detected in your system, an amber-colored attention LED on the operator panel is turned on solid (not blinking). Use the information in this topic along with the Start of call procedure to isolate a failing FRU (see [Start of call procedure](#)). You can use the service processor menus (available from the Advanced System Management Interface) or AIX Service Aid menu to blink the FRU LED for the failing FRU.

Individual LEDs are located on or near the failing field replaceable unit (FRU). The LEDs are located either on the component itself or on the carrier of the component (for example, memory card, fan, memory module, CPU). LEDs are either green or amber.

Green LEDs indicate either of the following:

- Electrical power is present.
- Activity is occurring on a link. (The system could be sending or receiving information.)

Amber LEDs indicate a fault or identify condition. If your system or one of the components in your system has an amber LED turned on or blinking, identify the problem and take the appropriate action to restore the system to normal.

The following table identifies the color and status of the component and attention LEDs. Units or FRUs may not have all of the LEDs listed in the table.

| Unit (FRU)       | LED Function   | LED Color | Off                          | On                          | Blink                |
|------------------|----------------|-----------|------------------------------|-----------------------------|----------------------|
| System attention | Attention      | Amber     | Normal                       | Fault                       | Identify             |
| System power     | Power          | Green     | No AC                        | System on                   | Standby              |
| Fan              | Identify       | Amber     | Normal                       |                             | Identify             |
|                  | Power          | Green     | No power                     | Power on                    |                      |
| Power supply     | AC input good  | Green     | No Input                     | Input good                  |                      |
|                  | Identify       | Amber     | Normal                       | Fault                       | Identify             |
|                  | DC output good | Green     | All power supply outputs off | All power supply outputs on | Control voltage good |
| Disk drives      | Activity       | Green     | No disk activity             | Disk being accessed         |                      |
|                  | Identify       | Amber     |                              |                             | Identify             |
| PCI slot         | Power          | Green     | No power                     | Power on                    |                      |

Service provider information

|                             |          |       |             |          |          |
|-----------------------------|----------|-------|-------------|----------|----------|
|                             | Identify | Amber | Normal      |          | Identify |
| RIO/HSL                     | Identify | Amber | Normal      |          | Identify |
| Memory DIMM                 | Identify | Amber | Normal      |          | Identify |
| System backplane            | Identify | Amber | Normal      |          | Identify |
| PCI riser card              | Power    | Green | No power    | Power on |          |
|                             | Identify | Amber | Normal      |          | Identify |
| Disk drive backplane        | Identify | Amber | Normal      |          | Identify |
| Media backplane             | Identify | Amber | Normal      |          | Identify |
| Service processor card      | Identify | Amber | Normal      |          | Identify |
| Voltage regulator module    | Identify | Amber | Normal      |          | Identify |
| RAID adapter card           | Identify | Amber | Normal      |          | Identify |
| HMC port                    | Link     | Green | No link     | Link     |          |
|                             | Activity | Green | No activity |          | Activity |
| Imbedded Ethernet           | Link     | Green | No link     | Link     |          |
|                             | Activity | Green | No activity |          | Activity |
| Node assembly               | Power    | Green | No power    | Power on |          |
|                             | Identify | Amber | Normal      |          | Identify |
| Bulk power controller (BPC) | Activity | Green | No power    | Power on |          |
|                             | Identify | Amber | Normal      |          | Identify |
| Motor drive assembly (MDA)  | Power    | Green | No power    | Power on |          |
| Motor scroll assembly (MSA) | Identify | Amber | Normal      |          | Identify |
| MCM                         | Identify | Amber | Normal      |          | Identify |
| Light strip                 | Power    | Green | No power    | Power on |          |
|                             | Identify | Amber | Normal      |          | Identify |

Parent topic: [Reference information](#)

## Memory plugging for models ESCALA PL 3250R and ESCALA PL 6450R

Provides guidelines for installing memory in a model ESCALA PL 3250R or 595 system.

For optimum performance, memory should be installed based on the following plugging order.

### Notes:

1. All memory in a node must be of the same size and type. There are two types of memory, DDR1 and DDR2. DDR1 is only offered as CuOD and DDR2 is only offered as non-CuOD.
2. Mixing of memory technologies within a node is not allowed. Because the voltage required by DDR 1 and DDR 2 devices is not the same, an individual node must be populated with only DDR 1 based cards or only with DDR 2 based cards.
3. Memory cards must be plugged in pairs. A valid minimum memory configuration within a node is 2 pairs of cards. Likewise a valid minimum memory configuration for a multinode system is 2 pairs of cards per processor node.
4. Not all of the memory cards seat in the same direction, for proper memory card seating, refer to [Removing and replacing parts on Model ESCALA PL 3250R and ESCALA PL 6450R](#).

The memory card plugging sequence within a single node is identified in the following table.

| Memory card plugging order | Location |
|----------------------------|----------|
| Memory card 1 (MCM 0)      | Px-C2    |
| Memory card 2 (MCM 0)      | Px-C4    |
| Memory card 3 (MCM 1)      | Px-C10   |
| Memory card 4 (MCM 1)      | Px-C12   |
| Memory card 5 (MCM 0)      | Px-C14   |
| Memory card 6 (MCM 0)      | Px-C15   |
| Memory card 15 (MCM 1)     | Px-C24   |
| Memory card 16 (MCM 1)     | Px-C25   |
| Memory card 8 (MCM 0)      | Px-C17   |
| Memory card 9 (MCM 0)      | Px-C18   |
| Memory card 12 (MCM 1)     | Px-C21   |
| Memory card 13 (MCM 1)     | Px-C22   |
| Memory card 7 (MCM 0)      | Px-C16   |
| Memory card 10 (MCM 0)     | Px-C19   |
| Memory card 11 (MCM 1)     | Px-C20   |
| Memory card 14 (MCM 1)     | Px-C23   |

For a multinode system the plugging sequence for memory cards is identified in the following table. For a 1 node system, use Column 1. For a 2 node system use column 2. For a 3 node system use column 3. For a 4 node system use column 4.

| 1 node (16 processor server) | 2 node (32 processor server) | 3 node (48 processor server) | 4 node (64 processor server) |
|------------------------------|------------------------------|------------------------------|------------------------------|
| Node 0, Memory card 1        | Node 0, Memory card 1        | Node 0, Memory card 1        | Node 0, Memory card 1        |
| Node 0, Memory card 2        | Node 0, Memory card 2        | Node 0, Memory card 2        | Node 0, Memory card 2        |
| Node 0, Memory card 3        | Node 1, Memory card 1        | Node 1, Memory card 1        | Node 1, Memory card 1        |
| Node 0, Memory card 4        | Node 1, Memory card 2        | Node 1, Memory card 2        | Node 1, Memory card 2        |
| Node 0, Memory card 5        | Node 0, Memory card 3        | Node 2, Memory card 1        | Node 2, Memory card 1        |
| Node 0, Memory card 6        | Node 0, Memory card 4        | Node 2, Memory card 2        | Node 2, Memory card 2        |
| Node 0, Memory card 15       | Node 1, Memory card 3        | Node 0, Memory card 3        | Node 3, Memory card 1        |
| Node 0, Memory card 16       | Node 1, Memory card 4        | Node 0, Memory card 4        | Node 3, Memory card 2        |
| Node 0, Memory card 8        | Node 0, Memory card 5        | Node 1, Memory card 3        | Node 0, Memory card 3        |
| Node 0, Memory card 9        | Node 0, Memory card 6        | Node 1, Memory card 4        | Node 0, Memory card 4        |
| Node 0, Memory card 12       | Node 1, Memory card 5        | Node 2, Memory card 3        | Node 1, Memory card 3        |
| Node 0, Memory card 13       | Node 1, Memory card 6        | Node 2, Memory card 4        | Node 1, Memory card 4        |
| Node 0, Memory card 7        | Node 0, Memory card 15       | Node 0, Memory card 5        | Node 2, Memory card 3        |
| Node 0, Memory card 10       | Node 0, Memory card 16       | Node 0, Memory card 6        | Node 2, Memory card 4        |
| Node 0, Memory card 11       | Node 1, Memory card 15       | Node 1, Memory card 5        | Node 3, Memory card 3        |
| Node 0, Memory card 14       | Node 1, Memory card 16       | Node 1, Memory card 6        | Node 3, Memory card 4        |
|                              | Node 0, Memory card 8        | Node 2, Memory card 5        | Node 0, Memory card 5        |
|                              | Node 0, Memory card 9        | Node 2, Memory card 6        | Node 0, Memory card 6        |
|                              | Node 1, Memory card 8        | Node 0, Memory card 15       | Node 1, Memory card 5        |
|                              | Node 1, Memory card 9        | Node 0, Memory card 16       | Node 1, Memory card 6        |

Service provider information

|  |                        |                        |                        |
|--|------------------------|------------------------|------------------------|
|  | Node 0, Memory card 12 | Node 1, Memory card 15 | Node 2, Memory card 5  |
|  | Node 0, Memory card 13 | Node 1, Memory card 16 | Node 2, Memory card 6  |
|  | Node 1, Memory card 12 | Node 2, Memory card 15 | Node 3, Memory card 5  |
|  | Node 1, Memory card 13 | Node 2, Memory card 16 | Node 3, Memory card 6  |
|  | Node 0, Memory card 7  | Node 0, Memory card 8  | Node 0, Memory card 15 |
|  | Node 0, Memory card 10 | Node 0, Memory card 9  | Node 0, Memory card 16 |
|  | Node 1, Memory card 7  | Node 1, Memory card 8  | Node 1, Memory card 15 |
|  | Node 1, Memory card 10 | Node 1, Memory card 9  | Node 1, Memory card 16 |
|  | Node 0, Memory card 11 | Node 2, Memory card 8  | Node 2, Memory card 15 |
|  | Node 0, Memory card 14 | Node 2, Memory card 9  | Node 2, Memory card 16 |
|  | Node 1, Memory card 11 | Node 0, Memory card 12 | Node 3, Memory card 15 |
|  | Node 1, Memory card 14 | Node 0, Memory card 13 | Node 3, Memory card 16 |
|  |                        | Node 1, Memory card 12 | Node 0, Memory card 8  |
|  |                        | Node 1, Memory card 13 | Node 0, Memory card 9  |
|  |                        | Node 2, Memory card 12 | Node 1, Memory card 8  |
|  |                        | Node 2, Memory card 13 | Node 1, Memory card 9  |
|  |                        | Node 0, Memory card 7  | Node 2, Memory card 8  |
|  |                        | Node 0, Memory card 10 | Node 2, Memory card 9  |
|  |                        | Node 1, Memory card 7  | Node 3, Memory card 8  |
|  |                        | Node 1, Memory card 10 | Node 3, Memory card 9  |
|  |                        | Node 2, Memory card 7  | Node 0, Memory card 12 |
|  |                        | Node 2, Memory card 10 | Node 0, Memory card 13 |
|  |                        | Node 0, Memory card 11 | Node 1, Memory card 12 |
|  |                        | Node 0, Memory card 14 | Node 1, Memory card 13 |
|  |                        | Node 1, Memory card 11 | Node 2, Memory card 12 |
|  |                        | Node 1, Memory card 14 | Node 2, Memory card 13 |
|  |                        | Node 2, Memory card 11 | Node 3, Memory card 12 |
|  |                        | Node 2, Memory card 14 | Node 3, Memory card 13 |
|  |                        |                        | Node 0, Memory card 7  |
|  |                        |                        | Node 0, Memory card 10 |
|  |                        |                        | Node 1, Memory card 7  |
|  |                        |                        | Node 1, Memory card 10 |
|  |                        |                        | Node 2, Memory card 7  |
|  |                        |                        | Node 2, Memory card 10 |
|  |                        |                        | Node 3, Memory card 7  |
|  |                        |                        | Node 3, Memory card 10 |
|  |                        |                        | Node 0, Memory card 11 |
|  |                        |                        | Node 0, Memory card 14 |
|  |                        |                        | Node 1, Memory card 11 |
|  |                        |                        | Node 1, Memory card 14 |
|  |                        |                        | Node 2, Memory card 11 |
|  |                        |                        | Node 2, Memory card 14 |
|  |                        |                        | Node 3, Memory card 11 |
|  |                        |                        | Node 3, Memory card 14 |

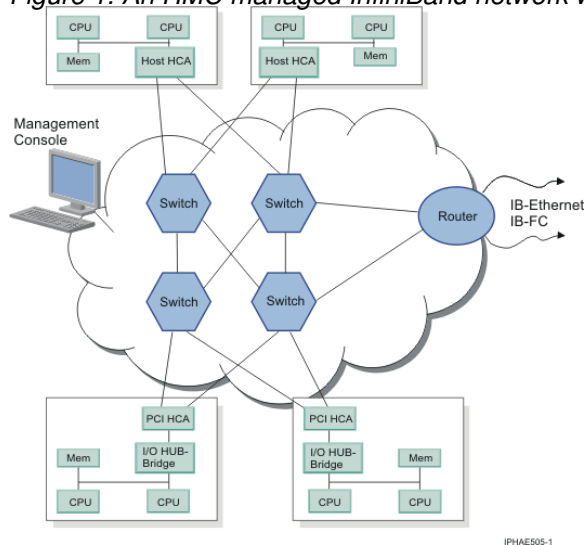
Parent topic: [Reference information](#)

## Clustering systems using InfiniBand (IB)

server hardware supports clustering through InfiniBand (IB) Host Channel Adapters (HSAs) and switches. The guide to [Clustering systems using InfiniBand \(IB\) hardware](#), provides planning and installing information to help guide you through the process of installing a cluster fabric that incorporates these switches. Also in this guide, there is information about how to manage and service an InfiniBand (IB) cluster.

The following illustration shows servers that are connected in a cluster configuration with InfiniBand switch networks (fabric). The servers in these networks can be connected through switches with either Peripheral Computer Interconnect (PCI) HCAs or GX Remote Input Output (RIO) adapter HCAs. Not all configurations support the following network configuration; refer to your sales information for supported configurations.

Figure 1. An HMC managed InfiniBand network with four switches (fabric) and four servers connected.



The following switch models are available:

- 481/20 (Topspin 120 Server Switch)
- 482/70 (Topspin 270 Server Switch)
- 487/00 (Cisco SFS 7000 Server Switch)
- 487/08 (Cisco SFS 7008 Server Switch)

If you are planning to use an InfiniBand switch in your clustered system configuration, the following table provides a list of InfiniBand hardware and software components available.

Table 1. InfiniBand network hardware solutions

| Solution components | PCI Host channel adapter                                                      | GX Host channel adapter                                                          |
|---------------------|-------------------------------------------------------------------------------|----------------------------------------------------------------------------------|
| Adapter             | PCI-X 4x IB Host Channel Adapter (HCA)                                        | GX 4x/12x IB Host Channel Adapter (HCA)                                          |
| Systems             | server, low-end                                                               | server, mid range, and high-end                                                  |
| Switches            | Topspin 120, Cisco 7000, Topspin 270, Cisco 7008                              |                                                                                  |
| Cables              | Certified cables                                                              |                                                                                  |
| Fabric Management   | Topspin WebUI and Element Manager                                             | IBM Network Manager                                                              |
| AIX version         | AIX 5L Version 5.3 with the 5300-03 Technology Level (APAR IY71011)           |                                                                                  |
| Linux version       | SUSE Linux Enterprise Server 9 (SP2) with Topspin Enterprise Commercial Stack | SUSE Linux Enterprise Server 9 (SP2) with IB GX HCA driver and OpenIB Gen2 Stack |

**Note:** See the [Facts and Features Web site](#) for the most recent information regarding cluster offerings.

#### Information resources

If you are planning to set up a clustered server configuration with InfiniBand (IB) switches, the information in this topic helps guide you through the process. This section also contains a framework of information to help you or your service representative to diagnose and resolve InfiniBand switch-network (fabric) problems. The following documentation is available here for your convenience:

#### Planning for InfiniBand Networks

- This documentation, [Guide to Clustering systems using InfiniBand hardware](#), provides planning and installing information to help guide you through installing a cluster fabric using InfiniBand switches
- [Managing your server using the Hardware Management Console \(HMC\)](#)
- [Topspin 120/Cisco SFS 7000 Hardware Guide](#)
- [Topspin 270/Cisco SFS 7008 Hardware Guide](#)
- [Hypertext Documentation Library documentation](#)

#### Installing InfiniBand Networks

The following guides are available to help you set up your network:

- This documentation, [Clustering systems using InfiniBand hardware](#), provides planning and installing information to guide you through the process of installing a cluster fabric using InfiniBand switches.
- [InfiniBand Hardware Installation and Cabling Guide Web Release](#), Topspin number: 10-00122-WEB
- [Topspin 120/Cisco SFS 7000 Quick Start Guide](#), order number: 10-00033-04-A0
- [Topspin 270/Cisco SFS 7008 Quick Start Guide](#), order number: 10-00045-04-A0

**Administering and Servicing InfiniBand Networks**If you need to do administrative tasks on your InfiniBand cluster, the following guides are available to help you. This documentation is also intended for use by service personnel:

- This documentation, [Guide to Clustering systems using InfiniBand hardware](#), provides a guide to help administer and service a cluster fabric using InfiniBand switches.
- [Element Manager User Guide](#), order number: 10-00116-02-A0
- [Chassis Manager User Guide](#), order number: 10-00029-05-A0
- [Command Line Interface Reference Guide](#), order number: 10-00012-07-A0
- [Host-side Drivers User Guide for Linux](#), order number: 10-00125-02-A0

**Parent topic:** [Reference information](#)

---

## Setting expansion unit configuration ID and MTMS value

Provides instructions for setting important system values.

The preferred method for setting the configuration ID is through the Advanced System Management Interface (ASMI), but it can also be performed using the physical control panel if the ASMI is unavailable.

The machine type-model-serial (MTMS) value for the expansion unit should be set to match the original value, which can be found on a label affixed to the expansion unit. Updating the MTMS value keeps the configuration and error information in sync, and is used by the system when creating the location codes. This must be done using the ASMI, not with the control panel. However, if you do not have access to the ASMI, the system will still operate without updating this information

**Note:** Refer to [Managing the Advanced System Management Interface \(ASMI\)](#) for information on setting up the ASMI, and [Managing your server using the Advanced System Management Interface](#) for information on using the ASMI, including updating the system configuration settings. [Updating the world-wide port name for a new 2766, 2787, or 280E IOA](#) Provides instructions for updating the world-wide port name after exchanging certain IOAs.

- [Using the ASMI to set the configuration ID and MTMS value](#)
- [Using the control panel to set the configuration ID](#)

Parent topic: [Reference information](#)

---

## Using the ASMI to set the configuration ID and MTMS value

To perform this operation, verify that the following prerequisites have been met:

- The server must be powered on to firmware standby or firmware running state.
- The expansion unit must be correctly installed in the system configuration and have ac power.
- Your authority level must be one of the following:
  - ◆ Administrator
  - ◆ Authorized service provider

1. Login in to ASMI.
2. Expand System Configuration.
3. Select Configure I/O Enclosures.
4. Select Clear inactive enclosures.
5. If you were directed here from a FRU replacement procedure, the FRU that was replaced contained the non-volatile storage where the expansion unit machine type-model-serial (MTMS) was stored. It is necessary to restore the expansion unit MTMS now. It may also be necessary to set or change the expansion unit configuration ID (power control network identifier).

The non-volatile storage where the expansion unit MTMS value is stored in a new replacement FRU is uninitialized. The system will detect the uninitialized value and assign an obvious, unique value of the form TMPx.xxx.xxxxxx, where x can be any character 0-9 and A-Z. As a result, the location code of the expansion unit will change to UTMPx.xxx.xxxxxx. You must first use the new UTMPx.xxx.xxxxxx location code listed below when selecting the expansion unit to power off and selecting the expansion unit to change settings for.

**Note:**

- a. Do not remove the ac power cord after powering off the expansion unit.
- b. If the expansion unit does not immediately appear on the service utility used to power off the expansion unit, refresh the utility periodically for up to ten minutes until it does. If it still does not appear, go step 1 and repeat this procedure.
- c. Remember to use the new UTMPx.xxx.xxxxxx location code when selecting the expansion unit to power off if you were directed here from a replacement procedure.
- d. If you were instructed by the procedure that sent you here when you were powering off the expansion unit to use panel function 69 to power on the expansion unit, perform panel function 69 now (with the control panel set to manual mode) from the system unit control panel (even though the expansion unit is already on). See [Control panel functions](#).

6. From the ASMI utility, expand System Configuration.
7. Select Configure I/O Enclosures.
8. Compare the power control network identifier value shown for the expansion unit you are working with to the power control network identifier (configuration ID) values in the table below. Compare the type-model and serial number values shown for the expansion unit you are working with to the type, model, and serial values on the label on the expansion unit. If any changes must be made, go to 9. Otherwise go to 21.

**Note:** Serial numbers are case sensitive. (All alpha characters contained in the serial number must be entered as a capital letter.)

- ◆ 71 for 1519-100 or 1519-200 IXA
- ◆ 81 for 50/74, 50/79, and 5097-002 expansion units.
- ◆ 89 for 50/88 and 05/88 expansion units.
- ◆ 8A for 50/94, 5097-001, , , and 9094 expansion units
- ◆ 8B for 50/95 and 05/95 expansion units.
- ◆ 88 for 11D/10, 11D/11, and 57/90 expansion units.
- ◆ 8C for 11D/20 expansion units.

9. If the server is powered on to firmware running state, go to 10. If the server is powered on to firmware standby state go to 11.
10. See the following notes, then go to [Powering off an expansion unit](#). Then continue with 11.

**Note:**

- ◆ Do not disconnect the ac power cables after powering off the expansion unit.
- ◆ If the expansion unit does not immediately appear on the service utility used to power off the expansion unit, refresh the utility periodically for up to ten minutes until it does. If it still does not appear, go step 1 and repeat this procedure.
- ◆ Remember to use the new UTMPx.xxx.xxxxxx location code when selecting the expansion unit to power off if you were directed here from a replacement procedure.
- ◆ If you were instructed by the procedure that sent you here when you were powering off the expansion unit to use panel function 69 to power on the expansion unit, perform panel function 69 now (with the control panel set to manual mode) from the system unit control panel (even though the expansion unit is already on). See [Control panel functions](#).

11. From the ASMI utility, expand System Configuration.
12. Select **Configure I/O Enclosure**.
13. Select the expansion unit you are working with.
14. Select **Change settings**.
15. If in 8 you determined that the power control network identifier value is not correct, enter the correct value now.
16. If in 8 you determined that the type-model and serial number values are not correct, enter the correct values now.

**Note:** Serial numbers are case sensitive. (All alpha characters contained in the serial number must be entered as a capital letter.)

17. Click **Save settings** to complete the operation
18. Verify that the values you just entered are reflected in the power control network identifier, type-model, serial number, and location code columns for the expansion unit you are working with. Do not use the browser back button to do this. Rather, expand system configuration. Then select **Configure I/O Enclosures**.

**Note:** Serial numbers are case sensitive. (All alpha characters contained in the serial number must be entered as a capital letter.)



19. If the server is powered on to firmware standby state and you entered a new power control network identifier in step 15, the expansion unit will power off and back on automatically. If this is the case, go to 21. Otherwise go to 20.
20. Power on the expansion unit.
  - ◆ If the system is not HMC-managed, disconnect all ac power to the expansion unit by disconnecting the ac cables from the power supplies on the expansion unit. Wait for the display panel to go off, and then reconnect the ac power cables. The expansion unit will power on automatically.
  - ◆ If the system is HMC-managed, power on the expansion unit using the Power On/Off unit utility. If the values you just entered are not immediately reflected in the location code of the expansion unit in the Power On/Off unit utility, restart the utility periodically for up to ten minutes until the values you entered are reflected. Go to [Powering on an expansion unit](#) for detailed instructions, then continue with 21.
21. Log off and close ASMI.
22. Return to the procedure that sent you here.

**Parent topic:** [Setting expansion unit configuration ID and MTMS value](#)

---

## Using the control panel to set the configuration ID

To perform this operation, verify that the following prerequisites have been met:

- The server must be powered on
- The expansion unit must be correctly installed in the system configuration and have ac power.

Control panel function 07 is used to query and set the configuration ID and to display the frame address of any tower connected to the SPCN network. Since the tower display panel will have the MTMS and not frame address displayed, a function is provided to display the frame address.

1. If you were directed here from a FRU replacement procedure, the FRU that was replaced contained the non-volatile storage where the expansion unit machine type-model-serial (MTMS) was stored. The non-volatile storage where the expansion unit MTMS value is stored in a new replacement FRU is uninitialized. The system will detect the uninitialized value and assign an obvious, unique value of the form TMPx.xxx.xxxxxx, where x can be any character 0-9 and A-Z. As a result, the location code of the expansion unit will change to UTMPx.xxx.xxxxxx. Use the new UTMPx.xxx.xxxxxx location code to power off the expansion unit. See the following notes, then go to [Powering off an expansion unit](#). Then return here and continue with the next step.

### Note:

- a. Do not remove the ac power cord after powering off the expansion unit.
  - b. If the expansion unit does not immediately appear on the service utility used to power off the expansion unit, refresh the utility periodically until it does. If a code update is occurring to the expansion unit, which is likely during a FRU replacement procedure that directs you here, it could take an extended period for the expansion unit to appear (possibly several hours on a large system).
  - c. Remember to use the new UTMPx.xxx.xxxxxx location code when selecting the expansion unit to power off if you were directed here from a replacement procedure.
  - d. If you were instructed by the procedure that sent you here when you were powering off the expansion unit to use panel function 69 to power on the expansion unit, perform panel function 69 now (with the control panel set to manual mode) from the system unit control panel (even though the expansion unit is already on). See [Control panel functions](#).
2. Select function 07 on the control panel and press Enter.
  3. Select sub function A6 to display the address of all units. The frame address is displayed on all units for 30 seconds.
  4. Note the frame address on the unit that you are working on for use in the next steps.
  5. Select sub function A9 to set the ID of a tower.

6. Use the arrow keys to increment/decrement to the first two digits of the frame address noted above.
7. Press enter
8. Use the arrow keys to increment or /decrement to the last two digits of the frame address noted above.
9. Press enter
10. Use the arrow keys to increment or decrement to a configuration ID for the type of unit you are working on:
  - ◆ 81 for 50/74 and 50/79 expansion units
  - ◆ 89 for 50/88 and 05/88 expansion units
  - ◆ 8A for 50/94 and 52/94 expansion units
  - ◆ 8B for 50/95 and 05/95 expansion units
  - ◆ 88 for 11D/10, 11D/11, and 57/90 expansion units
  - ◆ 8C for 11D/20 expansion units
11. Press Enter (078x 00 will be displayed).
12. Use the arrow keys to increment or decrement until 07\*\* is shown.
13. Press Enter to return the panel to 07.
14. Disconnect all ac power to the unit, wait for the display panel to go off and then reconnect the ac power.

**Note:** The expansion unit will automatically power on.

**Parent topic:** [Setting expansion unit configuration ID and MTMS value](#)

---

## Preventive maintenance

Provides instructions for system maintenance. Annually check and replace system filters as needed.

Do the following to access the Service Focal Point application:

1. Log into the HMC as the service representative.
2. In the Navigation area, select the Service Applications icon.
3. Select the Service Focal Point icon.
4. Select Exchange Parts. The Exchange Parts window opens. Follow the instructions on the Exchange Parts window until you reach the removal and replacement procedures for the selected part.

**Parent topic:** [Reference information](#)

---

## Related information for service provider information

Listed below are the Web sites and ESCALA Power5 Hardware Information topics that relate to the service provider information topic. You can view or print any of the PDFs.

### Web sites

- [ESCALA Power5 Hardware Information](#) The ESCALA Power5 Hardware Information is a source for technical information about the . The ESCALA Power5 Hardware Information is your starting point for all technical information.

### Other information

- [Accessing the Advanced System Management Interface](#)

- [Installing features](#)
- [Managing your server using the Hardware Management Console](#)
- [Managing your server using the Advanced System Management Interface](#)
- [Troubleshooting](#)

### Saving PDF files

To save a PDF on your workstation for viewing or printing:

1. Right-click the PDF in your browser (right-click the link above).
2. Click Save Target As... if you are using Internet Explorer. Click Save Link As... if you are using Netscape Communicator.
3. Navigate to the directory in which you would like to save the PDF.
4. Click Save.

### Downloading Adobe Acrobat Reader

You need Adobe Acrobat Reader to view or print these PDFs. You can download a copy from the [Adobe Web site](http://www.adobe.com/products/acrobat/readstep.html) (www.adobe.com/products/acrobat/readstep.html).

---

## What's new

Highlights changes and improvements to the Service provider information.

### What's new as of April 2006

The Start of Call Procedure has been expanded.

Support for the following hardware has been added:

- 10C/05 HMC.
- server
- server
- server
- 7/20 server
- ESCALA PL 250R-L+ or ESCALA PL 450R-VL+ server
- server
- server
- T24
- D24

### What's new as of 8 February 2005

Support for the following hardware has been added:

- 7/10 system models.
- ESCALA PL 250R-L system models.
- 5/75 system models.
- 10C/04 and 10C/R3 HMC models.

### What's new as of 1 October 2004

Support for the following hardware has been added:

- ESCALA PL 3250R and ESCALA PL 6450R system models.
- 57/90, 57/91, 57/94, and 406/1D expansion units.

### What's new as of 30 August 2004

Updates have been made throughout the topic to direct AIX and Linux users through the appropriate service path.

**Card positions** Missing card position information for some expansion units was added.

**Service processor isolation procedures** A number of the service processor isolation procedures were enhanced and revised.

**Addresses** New address information has been added for the model ESCALA PL 450T/R.

## What's new as of 30 July 2004

### Support for new hardware

- Information for servicing the following system units has been added: ESCALA PL 450T/R .
- Information has also been added for the following expansion units: 11D/10, 11D/11, and 11D/20.
- Information for servicing the model ESCALA PL 850R/PL 1650R/R+ has been updated to account for the optional secondary units.

### Support for AIX and Linux

- Isolation procedures have been added for servers running the AIX and Linux operating systems.
- The [Start of call procedure](#) has been updated to direct AIX and Linux users through the correct service path.
- [Working with AIX diagnostics](#) has been updated in the [Reference information](#) topic.

Parent topic: [Service provider information](#)

---

## Working with AIX diagnostics

Provides diagnostic information specific to AIX.

Working with AIX diagnostics is divided into three topics.

Use [General AIX diagnostic information](#) when you need to refer to information on the following subtopics:

- AIX operating system message files
- Firmware and microcode
- CERADME file
- CE login
- Automatic diagnostic tests
- CPU and memory testing and error log analysis
- Diagnostic programs
- Periodic diagnostics
- Automatic error log analysis (diagela)
- Log repair action
- System fault indicator and system identify indicator
- Array bit steering
- Running diagnostics on the native system port on a full machine partition with a HMC attached
- Enhanced I/O error handling

Use [Loading and Using the AIX online diagnostics or the standalone diagnostics](#) when you need to refer to information on the following subtopics:

- Standalone and online diagnostic operating considerations
- Online diagnostics mode of operations
- Standalone diagnostic operation
- General information about multiple systems
- Determining system architecture
- high-availability SCSI
- Diagnostic summary
- Diagnostics tasks and resources
- PCI SCSI RAID descriptions and diagnostic procedures

Use [AIX tasks and service aids](#) when you need to refer to information on the following tasks or service aids:

- Add resource to resource list
- AIX Shell Prompt
- Analyze Adapter Internal Log
- Backup and Restore Media

- Certify Media
  - Change Hardware Vital Product Data
  - Configure Dials and LPF Keys
  - Configure ISA Adapters
  - Configure Reboot Policy
  - Configure Remote Maintenance Policy
  - Configure Ring Indicate Power On (RSPC)
  - Configure Ring Indicate Power-On Policy
  - Configure Service Processor (RSPC)
  - Configure Scan Dump Policy
  - Configure Surveillance Policy
  - Create Customized Configuration Diskette
  - Delete Resource from Resource List
  - Disk Maintenance
  - Display Configuration and Resource List
  - Display Firmware Device Node Information
  - Display Hardware Error Report
  - Display Hardware Vital Product Data
  - Display Machine Check Error Log
  - Display Microcode Level
  - Display Multipath I/O (MPIO) Device Configuration
  - Display or Change Bootlist
  - Display or Change Diagnostic Run Time Options
  - Display Previous Diagnostic Results
  - Display Resource Attributes
  - Display Service Hints
  - Display Software Product Data
  - Display System Environmental Sensors
  - Display Test Patterns
  - Display USB Devices
  - Download Microcode
  - Fibre Channel RAID Service Aids
  - Flash SK-NET FDDI Firmware
  - Format Media
  - Gather System Information
  - Generic Microcode Download
  - Hot Plug Task
  - Identify Indicators
  - Identify and Remove Resource Task (See "Hot Plug Task" for AIX 4.3.3.10 or higher)
  - Identify and System Attention Indicators
  - Local Area Network Analyzer
  - Log Repair Action
  - Periodic Diagnostics
  - PCI SCSI Disk Identify Array Manager
  - PCI RAID Physical Disk Identify
  - Process Supplemental Media
  - Run Diagnostics
  - Run Error Log Analysis
  - Run Exercisers
  - Save or Restore Hardware Management Policies
  - Save or Restore Service Processor Configuration (RSPC)
  - SCSI Bus Analyzer
  - SCSI RAID Physical Disk Status and Vital Product Data
  - SCSD Tape Drive Service Aid
  - Spare Sector Availability
  - SSA Service Aid
  - System Fault Indicator
  - System Identify Indicator
  - Update Disk-Based Diagnostics
  - Update System or Service Processor Flash
  - Update System Flash (RSPC)
  - 7135 RAIDiant Array Service Aids
  - 7318 Serial Communication Network Server
- **General AIX diagnostic information**
  - **Loading and Using the AIX online diagnostics or the standalone diagnostics**  
Use this procedure to check the server or partition for correct hardware operation after removing and

replacing a part or installing a feature.

- **AIX tasks and service aids**

The AIX diagnostic package contains programs that are called Tasks.

Parent topic: [Reference information](#)

---

## Printable PDF

Provides access to a hardcopy, printable PDF of the service provider information topic.

To view or download the PDF version of this document select from the following:

- **Beginning problem analysis and isolation** (about 9.7 MB) Includes the Start of call procedure and problem determination procedures.
- **Reference codes** (about 12.3 MB) Includes information about system reference codes (SRCs), progress codes, and service request numbers (SRNs).
- **Locating and exchanging parts, and verifying the repair** (about 25 MB) Includes information for locating parts, determining the correct part number, removing and replacing parts, and verifying the repair.
- **Reference information** (about 1.5 MB) Includes additional information that may be of use to the service provider, such as data recovery procedures, AIX diagnostics, and HMC maintenance.
- **Service functions** (about 2.9 MB) Includes information about some of the service functions commonly used by authorized service providers.

### Saving PDF files

To save a PDF on your workstation for viewing or printing:

1. Right-click the PDF in your browser (right-click the link above).
2. Click Save Target As... if you are using Internet Explorer. Click Save Link As... if you are using Netscape Communicator.
3. Navigate to the directory in which you would like to save the PDF.
4. Click Save.

### Downloading Adobe Acrobat Reader

You need Adobe Acrobat Reader to view or print these PDFs. You can download a copy from the [Adobe Web site](http://www.adobe.com/products/acrobat/readstep.html) (www.adobe.com/products/acrobat/readstep.html) .

Parent topic: [Service provider information](#)

---

## Start of call procedure

Provides a starting point for analyzing problems. You should begin all service actions with this procedure.

This is the starting point for diagnosing and repairing servers. From this point, you will be guided to the appropriate information to help you diagnose server problems, determine the appropriate repair action, and then perform the necessary steps to repair the server. A system attention light indicates there is a serviceable event (an SRC in the control panel or in one of the serviceable event views) on the system. This procedure will guide you through finding the serviceable event.

**Note:** In this topic, control panel and operator panel are synonymous.

Before beginning, perform as many of the following tasks as possible:

**Note:** Ask the customer for the [Using the problem reporting forms](#) (available in the [Customer service, support, and troubleshooting](#) topic) that they should have completed when working with the support center.

- Verify the symptoms and service call data, including:
  - ◆ The server machine type, model number, and serial number.
  - ◆ The customer problem number.
  - ◆ A reference code (SRC, SRN or progress code). If you do not have a reference code, ask the customer for the date and time of the problem.
  - ◆ Any available location code information
  - ◆ Any data stored in:
    - ◇ the service action event log in Service Focal Point
    - ◇ other operating system-specific logs as directed
  - ◆ Symptoms reported to you by the customer.
  - ◆ Symptoms reported to you by the service support center.
  - ◆ Symptoms reported to you by an attached input/output (I/O) device, for example, a disk drive enclosure expansion drawer.
- Record information to help you return the server to the same state that the customer typically uses, such as:
  - ◆ The IPL type that the customer typically uses for the server. (See [Function 01: Display selected IPL type, system operating mode, and IPL speed](#) for more information.)
  - ◆ The [IPL mode](#) that is used by the customer on this server.
  - ◆ The way in which the server is configured or partitioned.
- Ensure that the customer has put the server into a state in which you can perform service tasks.

1. Is the failing component a monitor (display) or keyboard?

No:

Continue with the next step.

Yes:

Is the monitor or keyboard attached to a keyboard, video, mouse (KVM) switch?

No:

Continue with the next step.

Yes:

Go to [Troubleshooting the keyboard, video, and mouse \(KVM\) switch for the 1x8 and 2x8 console manager](#).

2. Is the failing unit an ESCALA PL 245T/R or a 471/85?

◆ No: Continue with the next step.

◆ Yes: Go to [Diagnosing a problem on an ESCALA PL 245T/R or a 471/85](#).

3. Is the failing server an xSeries or a BladeCenter blade server attached to a server through an iSCSI Host Bus Adapter (HBA)?

◆ No: Continue with the next step.

◆ Yes: Go to the [integrated xSeries troubleshooting procedure](#).

4. Is there a Hardware Management Console (HMC) attached to the failing unit?

◆ No: Continue with the next step.

◆ Yes: Continue with step 7.

5. Is this an HMC-managed system?

#### Notes:

- a. Look for HMC=x displayed in the control panel. The x represents a 0, 1, or 2, and depends on the number of HMCs attached to your server.
- b. Ask the customer.

c. If the server does not have a control panel, then it should have an HMC.

- ◆ No: Go to step 9.
- ◆ Yes: Continue with the next step.

6. Inform the customer that an HMC is required to continue servicing the system, and ask the customer to reattach the HMC to the server. When the HMC is reattached to the managed system, continue with the next step.
7. Is the HMC functional?
  - ◆ No: Go to [HMC problem isolation procedures](#). Once the HMC is functional, return here and continue with the next step.
  - ◆ Yes: Continue with the next step.
8. Perform the following steps from the HMC that is used to manage the server. During these steps, refer to the service data that was gathered earlier:
  - a. In the Navigation Area, open Service Applications.
  - b. Select Service Focal Point.
  - c. Select Repair Serviceable Event.
  - d. On the Select Failing System window, select the managed system that has the problem, and click OK.
  - e. Scroll through the log and verify that there is a problem with the status of Open to correspond with the customer's reported problem.

**Note:** If you are unable to locate the reported problem, and there is more than one open problem near the time of the reported failure, use the earliest problem in the log.

Do you find the reported problem, or an open problem near the time of the reported problem?

- ◆ No: Continue with the next step.
- ◆ Yes: Select the serviceable event you want to repair, and select Repair from the Selected menu.  
This launches a series of windows that guides you through the steps to repair the serviceable event. The system guides you through one of the two following methods of repair, depending on the type of FRU you need to exchange:
  - ◇ An interactive step-by-step process that provides illustrations and video presentations to help you exchange the FRU.
  - ◇ A link to the appropriate ESCALA Power5 Hardware Information topic that provides instructions to help you exchange the FRU.
 After you complete the repair procedure, the system automatically closes the serviceable event. This ends the procedure.

**Note:** If the Repair procedures are not available, continue with the next step.

9. Is there an eight-digit reference code (except Cxxxxxxx) displayed in function 11 on the control panel, or if applicable on the HMC?
  - ◆ No: Continue with the next step.
  - ◆ Yes: Record all reference code data, including the values for functions 11 through 20 (see [Collecting reference codes and system information](#)), and note the failing partition. Then, go to the [Reference codes](#) topic to further isolate the problem. This ends the procedure.

**Notes:** If you are working at an HMC, check the HMC for operator panel values by performing the following steps:

- a. In the Navigation Area, expand Server and Partition > Server Management.
- b. Choose from the following options:
  - ◇ To view managed system reference codes:
    - i. In the right pane, right-click the system and select Properties.
    - ii. Select the Reference Code tab to view the codes.
    - iii. When finished, click Cancel.
  - ◇ To view logical partition reference codes:
    - i. In the right pane expand the system that contains the partition.



- ii. Open Partitions.
- iii. Right-click the logical partition and select Properties.
- iv. Select the Reference Code tab to view the codes.
- v. When finished, click Cancel.

10. Is the system managed by the Integrated Virtualization Manager (IVM)?

**Note:** For information about the IVM, refer to [Managing the Integrated Virtualization Manager](#)

- ◆ Yes: Go to step [13](#).
- ◆ No: Continue with the next step.

11. Is an operating system console session available and can you log into the session?

**Notes:**

- a. For servers with logical partitions, the console session must be available for the failing partition.
- b. If you suspect a problem is on a device (a disk drive enclosure expansion drawer for example) that is attached to a server or a partition, the console session must be available for the partition to which the device is attached.
- c. See [5250 Console](#) in the Managing your server topic for details on accessing a 5250 console session on the HMC.

- ◆ Yes: Go to step [14](#).
- ◆ No: Continue with the next step.

12. Work with the customer to open an operating system console session. Can you successfully open an operating system console session?

- ◆ Yes: Go to step [14](#).
- ◆ No: Go to step [16](#).

13. Work with the customer to access the IVM web interface if it is not already running. Refer to [Connecting to Integrated Virtualization Manager](#). Can you successfully open the console session for IVM?

- ◆ Yes: Continue with the next step.
- ◆ No: Go to step [16](#).

14. Use the operating system-specific, the IVM-specific, or the Virtual I/O server (VIOS)-specific service tools and system logs to locate a "serviceable event" in the logs, or if there is no serviceable event, use the customer-reported symptom in step [14.b](#).

- a. Ask the customer for the date and time of the problem.

**Note:** If you are unable to locate the reported problem and there is more than one open problem near the time of the reported failure, use the earliest failure.

- b. Go to the appropriate procedure depending on the operating system, IVM, or VIOS that is reporting a problem.
  - ◇ If your server is managed by IVM, go to [Collect serviceable events in IVM](#), and then return here and continue on step [15](#).
  - ◇ If your server or partition is running AIX, go to [AIX fast-path problem isolation](#).
  - ◇ If your server or partition is running Linux, go to [Linux fast-path problem isolation](#).
  - ◇ If your server or partition is running a Virtual I/O Server partition, go to [Virtual I/O Server troubleshooting](#).

15. Did you find a reference code associated with this failure near the time of the reported problem?

- ◆ No: Continue with the next step.
- ◆ Yes: Collect all reference code data and note the failing partition. Go to the [Reference codes](#) topic to further isolate the problem. This ends the procedure.

16. Use the HMC or a web browser to access the Advanced System Management Interface (ASMI). See [Accessing the Advanced System Management Interface](#) for details. Then, perform the following steps:

- a. Log into the ASMI.

- b. Click the plus sign next to System Service Aids.
- c. Select Error/Event Logs to view the service processor error log.

**Note:** For more information on using the ASMI, see [Managing your server using the Advanced System Management Interface](#).

Were you able to access ASMI and is there a reference code in the service processor error log that requires service?

- ◆ No: Continue with the next step.
- ◆ Yes: Collect all reference code data and note the failing partition. Go to the [Reference codes](#) topic to further isolate the problem. This ends the procedure.

17. The following examples show the possible formats of reference codes that display during the power-on process:

- ◆ C1xx xxxx codes are displayed during the time after power is connected to the server until the service processor initial power-on process completes (indicated by "01" in the upper-left corner of the physical or logical control panel).
- ◆ C2xx xxxx and C7xx xxxx codes are displayed after the power-on sequence is initiated.
- ◆ CAxx xxxx codes are displayed while an AIX or Linux partition is initializing its resources.
- ◆ xxx, 0xxx, 2xxxx, or C6xx xxxx, C9xx xxxx codes are displayed during the time that the operating system boots and configures resources.
- ◆ 888-xxx code

Does the power-on process for the server appear to be stopped, and does function 11 display a reference code of a format shown in the list above?

- ◆ No: Go to the [Symptom index](#). This ends the procedure.
- ◆ Yes: Collect all reference code data and note the failing partition. Go to the [List of progress codes](#) topic to further isolate the problem. This ends the procedure.

- **Diagnosing a problem on an ESCALA PL 245T/R or a 471/85**

This is the entry procedure for diagnosing problems on an ESCALA PL 245T/R or a 471/85

Parent topic: [Service provider information](#)

---

## Collect serviceable events in IVM

Use this procedure when using Integrated Virtualization Manager (IVM) to check for serviceable events on your system.

1. Did you receive a reference code on the IVM console?

**Note:** For details on viewing reference codes using IVM, refer to [Using the Integrated Virtualization Manager](#).

Yes:

Record the reference code, and return to the procedure that sent you here to further isolate the problem.

No:

Continue with the next step to check for serviceable events.

2. In the IVM navigation bar, under Service Management, select **Manage Serviceable Events**.
3. In the Serviceable Event Selection Criteria field, select the criteria for the serviceable events that you want to view and click on **Apply**. The serviceable events appear in a table on your monitor. The table contains a list that shows all serviceable events matching your selection criteria.
4. Select one of the following options to perform an action on your serviceable events.
  - ◆ To view properties, continue with step 5.
  - ◆ To view associated FRUs, continue with step 6.

- ◆ To close a serviceable event, continue with step 7.
  - ◆ To view additional details for a serviceable event, continue with step 8.
5. To view properties for a serviceable event, select the serviceable event that you want to view properties for and select **Properties**. The Serviceable Event Comments window opens.
  6. To view associated field replaceable units (FRUs), select the serviceable event that you want to view FRUs for, and select **View associated FRUs**. The serviceable event window opens.
  7. To close a serviceable event, select one or more of the serviceable events that you want to close, and select **Close Events**. The Serviceable Event Comments window opens.
    - a. Enter comments if necessary, and click **Close Events**.
    - b. On the Close Serviceable Event dialog box, click **Yes** to close the serviceable event.
  8. To view additional details for a serviceable event, select the serviceable event that you want to view additional details for and select **View additional details**. The Serviceable Event Comments window opens.

**This ends this procedure.**

Parent topic: [Isolating problems](#)

---

## Diagnosing a problem on an ESCALA PL 245T/R or a 471/85

This is the entry procedure for diagnosing problems on an ESCALA PL 245T/R or a 471/85

If possible, leave the server in the state that it was in when the problem first occurred. Before you begin, visually check the system for symptoms, damage, or obvious problems such as unplugged or damaged power cables, correct external device cabling, or external devices that are powered off. Correct any problems that you find. Make a note of any symptoms that your server displays, such as:

- the system-attention light emitting diode (LED) is continuously illuminated.
- a reference code is displayed in the control (operator) panel display.
- you are having a problem with an adapter or an attached device.

**Note:** Because your server stores information about system operations even after the system unit is powered off, do not unplug the power cord from the system unit (or the power source) until you are instructed to do so later in these procedures.

1. Is the system-attention LED on the control panel illuminated continuously?
  - ◆ No: When the server is running, the system-attention LED is normally in the off state. However, you can manually put the LED in a blinking state to help identify the system unit. These states are normal and do not indicate a problem. To continue diagnosing a potential problem with your server, go to [additional diagnostic procedures](#).
  - ◆ Yes: A continuously illuminated system-attention LED means that the server has stored some information about a problem, and that you need to take an action to correct the problem. Continue with the next step.
2. Using care to not remove the power cord from the system unit or from the power source, remove the side cover from the system unit. See [Remove and replace model ESCALA PL 245T/R covers and doors](#). After the side cover is removed, continue with the next step.
3. Locate the light-path-diagnostic card which is located on the disk drive cage. Is there a fault-indicator LED that is continuously illuminated on the light-path-diagnostic card?

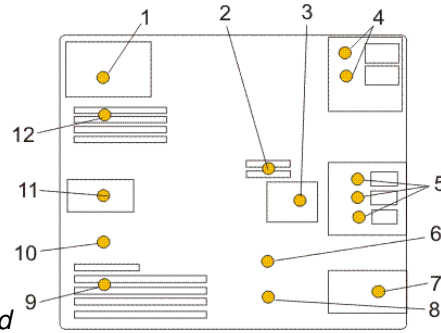


Figure 1. ESCALA PL 245T/R light-path-diagnostic card

Table 1. ESCALA PL 245T/R Fault-indicator LEDs

|                                                |                                   |
|------------------------------------------------|-----------------------------------|
| 1 Power supply fault-indicator LED             | 7 Front fan fault-indicator LED   |
| 2 Voltage-regulator module fault-indicator LED | 8 Battery fault-indicator LED     |
| 3 Disk-drive bay fan fault-indicator LED       | 9 PCI adapter fault-indicator LED |
| 4 Optical-media bay fault-indicator LEDs       | 10 Thermal fault-indicator LED    |
| 5 Disk-drive bay fault-indicator LEDs          | 11 Rear fan fault-indicator LED   |
| 6 System backplane fault-indicator LED         | 12 Memory fault-indicator LED     |

- ◆ No: To continue diagnosing a potential problem with your server, go to the [additional diagnostic procedures](#) in step 8.
- ◆ Yes: A continuously illuminated LED on the light-path-diagnostic card means that the server has detected a problem in the area of the server that is represented by the LED's position on the card. Continue with the next step.

4. Do one of the following actions:

**Note:** If you need to remove the air baffle, do not unplug the power cord from the server or the power source.

- ◆ If the thermal fault-indicator LED on the light-path-diagnostic card is illuminated and there are no other fault indicator LEDs illuminated, ensure that the air vents in the front and rear of the server are not blocked and that the room temperature is within the operational specifications.
  - ◆ If the light-path-diagnostic card indicates that you have a problem with a component that is located under the air baffle, such as a memory module or a voltage-regulator module, you must open the door on the air baffle to see the component-identification LEDs, see [Remove and replace model ESCALA PL 245T/R or a 471/85 covers and doors](#), then continue with step 5.
  - ◆ If the light-path-diagnostic card indicates that you have a problem with the battery, power supply, front fan, rear fan, disk-drive fan, disk drive in one of the bays, or a PCI adapter in a PCI slot, go to step 6.
5. After the air baffle door is opened, you can see components such as memory modules and voltage-regulator modules and the component-identification LEDs that identify which module has a problem. Using the position of the fault-indicator LED from the previous step and the flashing component-identification LED, determine which module in your server is failing. Continue with the next step.
6. Call your service organization and report that one of the parts from the following list has a problem:
- ◆ memory module (DIMM)
  - ◆ voltage-regulator module
  - ◆ system backplane

- ◆ battery, Non-Volatile Random Access Memory (NVRAM)
- ◆ power supply
- ◆ PCI adapter fan
- ◆ processor fan
- ◆ disk drive enclosure fan
- ◆ media device in one of the bays
- ◆ disk drive in one of the bays
- ◆ PCI adapter in a PCI slot

**Note:** The preceding parts are listed with their part numbers in the [Part number catalog](#).

When you receive the replacement part, continue with the next step.

7. Replace the part that was indicated by the fault-indicator LED. For removal and replacement instructions for the part, see [Installing features and replacing parts](#). **This ends the procedure.**
8. You are here because your server has a problem that cannot be identified by the system-attention LED and fault-indicator LEDs. From the following table, find a symptom that describes your server's symptoms and do the related action:

| Option                                                                                                                                                           | Description                                                                                                                                                                                                                                                                                                                                                                                                                                                                                                                                                                                                                                                                                                                                                                                                                                                                                                                                |
|------------------------------------------------------------------------------------------------------------------------------------------------------------------|--------------------------------------------------------------------------------------------------------------------------------------------------------------------------------------------------------------------------------------------------------------------------------------------------------------------------------------------------------------------------------------------------------------------------------------------------------------------------------------------------------------------------------------------------------------------------------------------------------------------------------------------------------------------------------------------------------------------------------------------------------------------------------------------------------------------------------------------------------------------------------------------------------------------------------------------|
| Symptom                                                                                                                                                          | Action                                                                                                                                                                                                                                                                                                                                                                                                                                                                                                                                                                                                                                                                                                                                                                                                                                                                                                                                     |
| The control (operator) panel is not illuminated.                                                                                                                 | Go to the <a href="#">Memory and processor subsystem problem isolation procedure</a> .                                                                                                                                                                                                                                                                                                                                                                                                                                                                                                                                                                                                                                                                                                                                                                                                                                                     |
| The control (operator) panel is blank except for a dot moving across the control panel display.                                                                  | <p>The dot moving across the control panel display indicates that the control panel is hung in a reset state. This symptom might occur if a control panel cable is incorrectly seated or plugged, if a control panel or cable is damaged, or if the wrong control panel is installed. Do the following:</p> <ul style="list-style-type: none"> <li>◆ Check and reconnect the control panel and cable connections. Refer to <a href="#">Model 7037-A50 and 7047-185 control panel</a></li> <li>◆ If reconnecting the control panel cable did not fix the problem, replace the control panel. For control panel removal and installation instructions go to <a href="#">Model ESCALA PL 245T/R and 7047-185 control panel</a>.</li> </ul> <p><b>Note:</b> After checking the above mentioned cables, plugs and control panel, and the symptom still has not been cleared, suspect the system backplane. Call your next level of support.</p> |
| There is a five, six, or eight character code displayed in the control (operator) panel.                                                                         | Go to <a href="#">Using system reference codes</a> .                                                                                                                                                                                                                                                                                                                                                                                                                                                                                                                                                                                                                                                                                                                                                                                                                                                                                       |
| The server appears to have stopped. There is a three or four character code continuously displayed in the control (operator) panel for an unusually long period. | Go to <a href="#">Using progress codes</a> .                                                                                                                                                                                                                                                                                                                                                                                                                                                                                                                                                                                                                                                                                                                                                                                                                                                                                               |
| There is a code with a hyphen (xxx-xxxx) displayed in the control (operator) panel.                                                                              | You have a Service Request Number (SRN); go to <a href="#">AIX problem analysis</a> .                                                                                                                                                                                                                                                                                                                                                                                                                                                                                                                                                                                                                                                                                                                                                                                                                                                      |
| The server appears to be looping. There is a series of three or four character codes repeatedly displaying in the control (operator) panel.                      | Go to <a href="#">Problems with loading and starting the operating system</a> .                                                                                                                                                                                                                                                                                                                                                                                                                                                                                                                                                                                                                                                                                                                                                                                                                                                            |
| The AIX operating system is available but you still have a problem.                                                                                              | You have a problem with an AIX server; go to <a href="#">AIX problem analysis</a> .                                                                                                                                                                                                                                                                                                                                                                                                                                                                                                                                                                                                                                                                                                                                                                                                                                                        |

|                                                                              |                                                                                                                                                                                                                                                                                                                       |
|------------------------------------------------------------------------------|-----------------------------------------------------------------------------------------------------------------------------------------------------------------------------------------------------------------------------------------------------------------------------------------------------------------------|
| <b>The Linux operating system is available but you still have a problem.</b> | You have a problem with a Linux server; go to <a href="#">Linux problem analysis</a> .                                                                                                                                                                                                                                |
| <b>The replacement part does not fix the problem.</b>                        | After the part is replaced, complete the <a href="#">system verification procedure</a> . If your server shows the same symptoms, call your next level of support.<br><br>If your server shows different symptoms than before, diagnose the new symptoms. Return to the <a href="#">first step of this procedure</a> . |
| <b>Find a System Reference Code (SRC) using the Operator Panel functions</b> | Go to <a href="#">Control panel functions</a> .                                                                                                                                                                                                                                                                       |
| <b>Find an SRC using the System Management Services</b>                      | Go to <a href="#">Managing the system management services</a> .                                                                                                                                                                                                                                                       |
| <b>AIX diagnostics</b>                                                       | Go to <a href="#">Working with AIX diagnostics</a> .                                                                                                                                                                                                                                                                  |
| <b>Linux tool kit Web page</b>                                               | Go to <a href="#">Obtaining service and productivity tools for Linux</a> .                                                                                                                                                                                                                                            |
| <b>Firmware update procedures</b>                                            | Go to <a href="#">Getting server firmware fixes for an ESCALA PL 245T/R or 7047-185 system</a> .                                                                                                                                                                                                                      |

Parent topic: [Start of call procedure](#)

---

## Symptom index

Use this symptom index only when you are guided here by the Start of call procedure.

**Note:** If you were not guided here from the [Start of call procedure](#), return there and follow the instructions given in that procedure.

Review the symptoms in the left column. Look for the symptom that most closely matches the symptoms on the server that you are troubleshooting. When you find the matching symptom, perform the appropriate action as described in the right column.

Table 1. Determining symptom types

| Symptom                                                             | What you should do:                                              |
|---------------------------------------------------------------------|------------------------------------------------------------------|
| You do not have a symptom.                                          | Go to the <a href="#">Start of call procedure</a> .              |
| The symptom or problem is on a server or a partition running AIX.   | Go to <a href="#">AIX server or AIX partition symptoms</a> .     |
| The symptom or problem is on a server or a partition running Linux. | Go to <a href="#">Linux server or Linux partition symptoms</a> . |

## AIX server or AIX partition symptoms

Use the following tables to find the symptom you are experiencing. If you cannot find your symptom, contact your next level of support.

Choose the description that best describes your situation:

- [You have a service action to perform](#)
- [Integrated Virtualization Manager \(IVM\) Problem](#)
- [An LED is not operating as expected](#)
- [Control \(operator\) panel problems](#)
- [Reference codes](#)
- [Hardware Management Console \(HMC\) Problem](#)
- [There is a display or monitor problem \(for example, distortion or blurring\)](#)
- [Power and cooling problems](#)
- [Other symptoms or problems](#)

### You have a service action to perform

| Symptom                                                                             | What you should do:                                                                                                                                               |
|-------------------------------------------------------------------------------------|-------------------------------------------------------------------------------------------------------------------------------------------------------------------|
| You have an open service event in the service action event log.                     | Go to <a href="#">Start of call procedure</a> .                                                                                                                   |
| You have parts to exchange or a corrective action to perform.                       | <ol style="list-style-type: none"> <li>1. Go to <a href="#">Removing and replacing parts</a>.</li> <li>2. Go to <a href="#">End-of-call procedure</a>.</li> </ol> |
| You need to verify that a part exchange or corrective action corrected the problem. | <ol style="list-style-type: none"> <li>1. Go to <a href="#">Verifying the repair</a>.</li> <li>2. Go to the <a href="#">End-of-call procedure</a>.</li> </ol>     |
| You need to verify correct system operation.                                        | <ol style="list-style-type: none"> <li>1. Go to <a href="#">Verifying the repair</a>.</li> <li>2. Go to <a href="#">End-of-call procedure</a>.</li> </ol>         |

### Integrated Virtualization Manager (IVM) Problem

| Symptom                                                             | What you should do:                                                                                             |
|---------------------------------------------------------------------|-----------------------------------------------------------------------------------------------------------------|
| The partitions do not activate - partition configuration is damaged | Restore the partition configuration data using IVM. See <a href="#">Backing up and restoring partition data</a> |
| Other partition problems when the server is managed by IVM          | Perform <a href="#">Troubleshooting with the Integrated Virtualization Manager</a>                              |

### An LED is not operating as expected

| Symptom | What you should do:                             |
|---------|-------------------------------------------------|
|         | Go to <a href="#">Start of call procedure</a> . |

|                                                                           |                                                                                                                                                                                                                                                                                                                                                                                                                                                                                                                    |
|---------------------------------------------------------------------------|--------------------------------------------------------------------------------------------------------------------------------------------------------------------------------------------------------------------------------------------------------------------------------------------------------------------------------------------------------------------------------------------------------------------------------------------------------------------------------------------------------------------|
| The system attention LED on the control panel is on.                      |                                                                                                                                                                                                                                                                                                                                                                                                                                                                                                                    |
| The rack identify LED does not operate properly.                          | Go to <a href="#">AIX fast-path problem isolation</a> .                                                                                                                                                                                                                                                                                                                                                                                                                                                            |
| The rack indicator LED does not turn on, but a drawer identify LED is on. | <ol style="list-style-type: none"> <li>1. Make sure the rack indicator LED is properly mounted to the rack.</li> <li>2. Make sure that the rack identify LED is properly cabled to the bus bar on the rack and to the drawer identify LED connector.</li> <li>3. Replace the following parts one at a time: <ul style="list-style-type: none"> <li>◆ Rack LED to bus bar cable</li> <li>◆ LED bus bar to drawer cable</li> <li>◆ LED bus bar</li> </ul> </li> <li>4. Contact your next level of support</li> </ol> |

### Control (operator) panel problems

| Symptom                                                                                                                                                                                                                                            | What you should do:                                                                                                                                                                                                                                                                                                                                                                                                                                                                                                                                                                                                                                                                                                                                                                                                                                                                                                                                                                                                                                                                                                                                                                                                                                                                                                               |
|----------------------------------------------------------------------------------------------------------------------------------------------------------------------------------------------------------------------------------------------------|-----------------------------------------------------------------------------------------------------------------------------------------------------------------------------------------------------------------------------------------------------------------------------------------------------------------------------------------------------------------------------------------------------------------------------------------------------------------------------------------------------------------------------------------------------------------------------------------------------------------------------------------------------------------------------------------------------------------------------------------------------------------------------------------------------------------------------------------------------------------------------------------------------------------------------------------------------------------------------------------------------------------------------------------------------------------------------------------------------------------------------------------------------------------------------------------------------------------------------------------------------------------------------------------------------------------------------------|
| 01 does not appear in the upper-left corner of the operator panel display after the power is connected and before pressing the power-on button. Other symptoms appear in the operator panel display or LEDs before the power on button is pressed. | Go to <a href="#">Power problems</a> .                                                                                                                                                                                                                                                                                                                                                                                                                                                                                                                                                                                                                                                                                                                                                                                                                                                                                                                                                                                                                                                                                                                                                                                                                                                                                            |
| A bouncing or scrolling ball remains on the operator panel display, or the operator panel display is filled with dashes or blocks.                                                                                                                 | <p>Verify that the operator panel connections to the system backplane are connected and properly seated.</p> <p>If a client computer (such as a PC with Ethernet capability and a Web browser) is available, connect it to the service processor in the server that is displaying the symptom.</p> <p>To connect a personal computer with Ethernet capability and a Web browser, or an ASCII terminal, to access the Advanced System Management Interface (ASMI), go to <a href="#">Managing your server using the Advanced System Management Interface</a>.</p> <ul style="list-style-type: none"> <li>• If you can successfully access the ASMI, replace the operator panel assembly. Refer to <a href="#">Finding part locations</a> to determine the part number and correct exchange procedure.</li> <li>• If you cannot successfully access the ASMI, replace the service processor. Refer to <a href="#">Finding part locations</a> to determine the part number and correct exchange procedure.</li> </ul> <p>If you do not have a PC or ASCII terminal, replace the following one at a time (go to <a href="#">Finding part locations</a> to determine the part number and correct exchange procedure):</p> <ol style="list-style-type: none"> <li>1. Operator panel assembly.</li> <li>2. Service processor.</li> </ol> |
| You have a blank display on the operator panel. Other LEDs on the operator panel appear to behave                                                                                                                                                  |                                                                                                                                                                                                                                                                                                                                                                                                                                                                                                                                                                                                                                                                                                                                                                                                                                                                                                                                                                                                                                                                                                                                                                                                                                                                                                                                   |



|                                                                                           |                                                                                                                                                                                                                                                    |
|-------------------------------------------------------------------------------------------|----------------------------------------------------------------------------------------------------------------------------------------------------------------------------------------------------------------------------------------------------|
| normally.                                                                                 | <ol style="list-style-type: none"> <li>1. Replace the operator panel assembly. Refer to <a href="#">Removing and replacing parts</a>.</li> <li>2. Replace the service processor. Refer to <a href="#">Removing and replacing parts</a>.</li> </ol> |
| You have a blank display on the operator panel. Other LEDs on the operator panel are off. | Go to <a href="#">Power problems</a> .                                                                                                                                                                                                             |
| An 888 sequence is displayed in the operator panel display.                               | Go to <a href="#">AIX fast-path problem isolation</a> .                                                                                                                                                                                            |

## Reference codes

| Symptom                                                                                                                               | What you should do:                                                                                                                                                                                                                                                                                                                                                                                                                                                                                                                                                                                                                                                                                                                                                                                                                                          |
|---------------------------------------------------------------------------------------------------------------------------------------|--------------------------------------------------------------------------------------------------------------------------------------------------------------------------------------------------------------------------------------------------------------------------------------------------------------------------------------------------------------------------------------------------------------------------------------------------------------------------------------------------------------------------------------------------------------------------------------------------------------------------------------------------------------------------------------------------------------------------------------------------------------------------------------------------------------------------------------------------------------|
| You have an 8-digit error code displayed.                                                                                             | <p>Look up the reference code in the <a href="#">Reference codes</a> section of the ESCALA Power5 Hardware Information.</p> <p><b>Note:</b> If the repair for this code does not involve replacing a FRU (for instance, running an AIX command that fixes the problem or changing a hot-pluggable FRU), then update the AIX error log after the problem is resolved by performing the following steps:</p> <ol style="list-style-type: none"> <li>1. In the online diagnostics, select Task Selection &gt; Log Repair Action.</li> <li>2. Select resource sysplanar0.</li> </ol> <p>On systems with a fault indicator LED, this changes the fault indicator LED from the fault state to the normal state.</p>                                                                                                                                                |
| The system stops with an 8-digit error code displayed when booting.                                                                   | Look up the reference code in the <a href="#">Reference codes</a> section of the ESCALA Power5 Hardware Information.                                                                                                                                                                                                                                                                                                                                                                                                                                                                                                                                                                                                                                                                                                                                         |
| The system stops and a 4-digit code displays on the control panel that does not begin with 0 or 2.                                    | Look up the reference code in the <a href="#">Reference codes</a> section of the ESCALA Power5 Hardware Information.                                                                                                                                                                                                                                                                                                                                                                                                                                                                                                                                                                                                                                                                                                                                         |
| The system stops and a 4-digit code displays on the control panel that begins with 0 or 2 is displayed in the operator panel display. | Record SRN 101-xxxx where xxxx is the 4-digit code displayed in the control panel, then look up this reference code in the <a href="#">Reference codes</a> section of the ESCALA Power5 Hardware Information. Follow the instructions given in the Description and Action column for your SRN.                                                                                                                                                                                                                                                                                                                                                                                                                                                                                                                                                               |
| The system stops and a 3-digit number displays on the control panel.                                                                  | <p>Add 101 to the left of the three digits to create an SRN, then look up this reference code in the <a href="#">Reference codes</a> section of the ESCALA Power5 Hardware Information. Follow the instructions given in the Description and Action column for your SRN.</p> <p>If there is a location code displayed under the 3-digit error code, look at the location to see if it matches the failing component that the SRN pointed to. If they do not match, perform the action given in the error code table. If the problem still exists, replace the failing component from the location code.</p> <p>If there is a location code displayed under the 3-digit error code, record the location code.</p> <p>Record SRN 101-xxx, where xxx is the 3-digit number displayed in the operator panel display, then look up this reference code in the</p> |

[Reference codes](#) section of the ESCALA Power5 Hardware Information. Follow the instructions given in the Description and Action column for your SRN.

## Hardware Management Console (HMC) Problem

| Symptom                                                                                                                                 | What you should do:                                                                                                                                                                                                                                                                                                                                                                                                                                                                                                                                                                                                                                                                                                                                                                                                                                                                                                                                                                                                                                                                                                                                                                                                                                                                                                                                                                                                                                                                                                                                                                                                                                                                                                                                                                |
|-----------------------------------------------------------------------------------------------------------------------------------------|------------------------------------------------------------------------------------------------------------------------------------------------------------------------------------------------------------------------------------------------------------------------------------------------------------------------------------------------------------------------------------------------------------------------------------------------------------------------------------------------------------------------------------------------------------------------------------------------------------------------------------------------------------------------------------------------------------------------------------------------------------------------------------------------------------------------------------------------------------------------------------------------------------------------------------------------------------------------------------------------------------------------------------------------------------------------------------------------------------------------------------------------------------------------------------------------------------------------------------------------------------------------------------------------------------------------------------------------------------------------------------------------------------------------------------------------------------------------------------------------------------------------------------------------------------------------------------------------------------------------------------------------------------------------------------------------------------------------------------------------------------------------------------|
| <p>Hardware Management Console (HMC) cannot be used to manage a managed system, or the connection to the managed system is failing.</p> | <p>If the managed system is operating normally (no error codes or other symptoms), the HMC might have a problem, or the connection to the managed system might be damaged or incorrectly cabled. Do the following:</p> <ol style="list-style-type: none"> <li>1. Check the connections between the HMC and the managed system. Correct any cabling errors if found. If another cable is available, connect it in place of the existing cable and refresh the HMC interface. You may have to wait up to 30 seconds for the managed system to reconnect.</li> <li>2. Verify that any connected HMC is connected to the managed system by checking the Management Environment of the HMC.</li> </ol> <p><b>Note:</b> The managed system must have power connected, and either be waiting for a power-on instruction (01 is in the upper-left corner of the operator panel), or be running.</p> <p>If the managed system does not appear in the Navigation area of the HMC Management Environment, the HMC or the connection to the managed system might be failing.</p> <ol style="list-style-type: none"> <li>3. Go to the Entry MAP in the <a href="#">Managing your server using the Hardware Management Console</a> section.</li> <li>4. There might be a problem with the service processor card or the system backplane. If you cannot fix the problem using the HMC tests in the <a href="#">Managing your server using the Hardware Management Console</a> section: <ol style="list-style-type: none"> <li>a. Replace the service processor card. Refer to <a href="#">Removing and replacing parts</a>.</li> <li>b. Replace the system backplane if not already replaced in substep "a" above. Refer to <a href="#">Removing and replacing parts</a>.</li> </ol> </li> </ol> |
| <p>Hardware Management Console (HMC) cannot call out using the attached modem and the customer's telephone line.</p>                    | <p>If the managed system is operating normally (no error codes or other symptoms), the HMC might have a problem, or the connection to the modem and telephone line might have a problem. Do the</p>                                                                                                                                                                                                                                                                                                                                                                                                                                                                                                                                                                                                                                                                                                                                                                                                                                                                                                                                                                                                                                                                                                                                                                                                                                                                                                                                                                                                                                                                                                                                                                                |

|  |                                                                                                                                                                                                                                                                                                                |
|--|----------------------------------------------------------------------------------------------------------------------------------------------------------------------------------------------------------------------------------------------------------------------------------------------------------------|
|  | <p>following:</p> <ol style="list-style-type: none"> <li>1. Check the connections between the HMC and the modem and telephone line. Correct any cabling errors if found.</li> <li>2. Go to the Entry MAP in the <a href="#">Managing your server using the Hardware Management Console</a> section.</li> </ol> |
|--|----------------------------------------------------------------------------------------------------------------------------------------------------------------------------------------------------------------------------------------------------------------------------------------------------------------|

### There is a display problem (for example, distortion or blurring)

| Symptom                                                                 | What you should do:                                                                                                                                                                                                                                                                                                                                                                                                                                                                                                                                                                                                                                                                                                                                                                                                                                                                                                                                                                                                                                                                   |
|-------------------------------------------------------------------------|---------------------------------------------------------------------------------------------------------------------------------------------------------------------------------------------------------------------------------------------------------------------------------------------------------------------------------------------------------------------------------------------------------------------------------------------------------------------------------------------------------------------------------------------------------------------------------------------------------------------------------------------------------------------------------------------------------------------------------------------------------------------------------------------------------------------------------------------------------------------------------------------------------------------------------------------------------------------------------------------------------------------------------------------------------------------------------------|
| All display problems.                                                   | <ol style="list-style-type: none"> <li>1. If you are using the Hardware Management Console, go to the <a href="#">Managing your server using the Hardware Management Console</a> section.</li> <li>2. If you are using a graphics display: <ol style="list-style-type: none"> <li>a. Go to the problem determination procedures for the display.</li> <li>b. If you do not find a problem: <ul style="list-style-type: none"> <li>◇ Replace the graphics display adapter. Refer to <a href="#">Removing and replacing parts</a>.</li> <li>◇ Replace the backplane into which the card is plugged. Refer to <a href="#">Removing and replacing parts</a>.</li> </ul> </li> </ol> </li> <li>3. If you are using an ASCII terminal: <ol style="list-style-type: none"> <li>a. Make sure that the ASCII terminal is connected to S1.</li> <li>b. If problems persist, go to the problem determination procedures for the terminal.</li> <li>c. If you do not find a problem, replace the service processor. Refer to <a href="#">Removing and replacing parts</a>.</li> </ol> </li> </ol> |
| There appears to be a display problem (distortion, blurring, and so on) | Go to the problem determination procedures for the display.                                                                                                                                                                                                                                                                                                                                                                                                                                                                                                                                                                                                                                                                                                                                                                                                                                                                                                                                                                                                                           |

### Power and cooling problems

| Symptom                                                                                                          | What you should do:                                                                                                                           |
|------------------------------------------------------------------------------------------------------------------|-----------------------------------------------------------------------------------------------------------------------------------------------|
| The system will not power on and no error codes are available.                                                   | Go to <a href="#">Power problems</a> .                                                                                                        |
| The power LEDs on the operator panel and the power supply do not come on or stay on.                             | <ol style="list-style-type: none"> <li>1. Check the service processor error log.</li> <li>2. Go to <a href="#">Power problems</a>.</li> </ol> |
| The power LEDs on the operator panel and the power supply come on and stay on, but the system does not power on. |                                                                                                                                               |

|                                                                                            |                                                                                                                                               |
|--------------------------------------------------------------------------------------------|-----------------------------------------------------------------------------------------------------------------------------------------------|
|                                                                                            | <ol style="list-style-type: none"> <li>1. Check the service processor error log.</li> <li>2. Go to <a href="#">Power problems</a>.</li> </ol> |
| A rack or a rack-mounted unit will not power on.                                           | <ol style="list-style-type: none"> <li>1. Check the service processor error log.</li> <li>2. Go to <a href="#">Power problems</a>.</li> </ol> |
| The cooling fan(s) do not come on, or come on but do not stay on.                          | <ol style="list-style-type: none"> <li>1. Check the service processor error log.</li> <li>2. Go to <a href="#">Power problems</a>.</li> </ol> |
| The system attention LED on the operator panel is on and there is no error code displayed. | <ol style="list-style-type: none"> <li>1. Check the service processor error log.</li> <li>2. Go to <a href="#">Power problems</a>.</li> </ol> |

### Other symptoms or problems

| Symptom                                                                                                                                                                                                                                                                                                                                                                               | What you should do:                                                                                                                                                                                                                                                                                                                                  |
|---------------------------------------------------------------------------------------------------------------------------------------------------------------------------------------------------------------------------------------------------------------------------------------------------------------------------------------------------------------------------------------|------------------------------------------------------------------------------------------------------------------------------------------------------------------------------------------------------------------------------------------------------------------------------------------------------------------------------------------------------|
| The system stopped and a code is displayed on the operator panel.                                                                                                                                                                                                                                                                                                                     | Go to <a href="#">Start of call procedure</a> .                                                                                                                                                                                                                                                                                                      |
| 01 is displayed in the upper-left corner of the operator panel and the fans are off.                                                                                                                                                                                                                                                                                                  | The service processor is ready. The system is waiting for power-on. Boot the system. If the boot is unsuccessful, and the system returns to the default display (indicated by 01 in the upper-left corner of the operator panel), go to <a href="#">MAP 0020: Problem determination procedure</a> .                                                  |
| The operator panel displays STBY.                                                                                                                                                                                                                                                                                                                                                     | <p>The service processor is ready. The server was shut down by the operating system and is still powered on. This condition can be requested by a privileged system user with no faults. Go to <a href="#">Start of call procedure</a>.</p> <p><b>Note:</b> See the service processor error log for possible operating system fault indications.</p> |
| All of the system POST indicators are displayed on the firmware console, the system pauses and then restarts. The term <i>POST indicators</i> refers to the device mnemonics (the words <code>memory</code> , <code>keyboard</code> , <code>network</code> , <code>scsi</code> , and <code>speaker</code> ) that appear on the firmware console during the power-on self-test (POST). | Go to <a href="#">Problems with loading and starting the operating system</a> .                                                                                                                                                                                                                                                                      |
| The system stops and all of the POST indicators are displayed on the firmware console. The term <i>POST indicators</i> refers to the device mnemonics (the words <code>memory</code> , <code>keyboard</code> , <code>network</code> , <code>scsi</code> , and <code>speaker</code> ) that appear on the firmware console during the power-on self-test (POST).                        | Go to <a href="#">Problems with loading and starting the operating system</a> .                                                                                                                                                                                                                                                                      |

|                                                                                                                                                          |                                                                                                                                                                                                                                                                                                                                                                                                                                                                                                                                                                                                                                                                                                                                                                                                                                                          |
|----------------------------------------------------------------------------------------------------------------------------------------------------------|----------------------------------------------------------------------------------------------------------------------------------------------------------------------------------------------------------------------------------------------------------------------------------------------------------------------------------------------------------------------------------------------------------------------------------------------------------------------------------------------------------------------------------------------------------------------------------------------------------------------------------------------------------------------------------------------------------------------------------------------------------------------------------------------------------------------------------------------------------|
| The system stops and the message <code>starting software please wait...</code> is displayed on the firmware console.                                     | Go to <a href="#">Problems with loading and starting the operating system</a> .                                                                                                                                                                                                                                                                                                                                                                                                                                                                                                                                                                                                                                                                                                                                                                          |
| The system does not respond to the password being entered or the system login prompt is displayed when booting in service mode.                          | <ol style="list-style-type: none"> <li>1. If the password is being entered from the Hardware Management Console (HMC), go to the <a href="#">Managing your server using the Hardware Management Console</a>.</li> <li>2. If the password is being entered from a keyboard attached to the system, the keyboard or its controller may be faulty. In this case, replace these parts in the following order: <ol style="list-style-type: none"> <li>a. Keyboard</li> <li>b. Service processor</li> </ol> </li> <li>3. If the password is being entered from an ASCII terminal, use the problem determination procedures for the ASCII terminal. Make sure the ASCII terminal is connected to S1.</li> </ol> <p>If the problem persists, replace the service processor.</p> <p>If the problem is fixed, go to <a href="#">MAP 0410: Repair checkout</a>.</p> |
| The system stops with a prompt to enter a password.                                                                                                      | Enter the password. You cannot continue until a correct password has been entered. When you have entered a valid password, go to the beginning of this table and wait for one of the other conditions to occur.                                                                                                                                                                                                                                                                                                                                                                                                                                                                                                                                                                                                                                          |
| The system does not respond when the password is entered.                                                                                                | Go to <a href="#">Step 1020-2</a> .                                                                                                                                                                                                                                                                                                                                                                                                                                                                                                                                                                                                                                                                                                                                                                                                                      |
| No codes are displayed on the operator panel within a few seconds of turning on the system. The operator panel is blank before the system is powered on. | <p>Reseat the operator panel cable. If the problem is not resolved, replace in the following order:</p> <ol style="list-style-type: none"> <li>1. Operator panel assembly. Refer to <a href="#">Removing and replacing parts</a></li> <li>2. Service processor. Refer to <a href="#">Removing and replacing parts</a>.</li> </ol> <p>If the problem is fixed, go to <a href="#">MAP 0410: Repair checkout</a>.</p> <p>If the problem is still not corrected, go to <a href="#">MAP 0020: Problem determination procedure</a>.</p>                                                                                                                                                                                                                                                                                                                        |
| The SMS configuration list or boot sequence selection menu shows more SCSI devices attached to a controller/adaptor than are actually attached.          | <p>A device may be set to use the same SCSI bus ID as the control adapter. Note the ID being used by the controller/adaptor (this can be checked and/or changed through an SMS utility), and verify that no device attached to the controller is set to use that ID.</p> <p>If settings do not appear to be in conflict:</p> <ol style="list-style-type: none"> <li>1. Go to <a href="#">MAP 0020: Problem determination procedure</a>.</li> <li>2. Replace the SCSI cable.</li> <li>3. Replace the device.</li> <li>4. Replace the SCSI adapter</li> </ol>                                                                                                                                                                                                                                                                                              |

|                                                                                                                                                     |                                                                                                                                                                                                                                                                                                                                                                                                                                                                                                                                                                                                                                                                                                                                                                                                                                           |
|-----------------------------------------------------------------------------------------------------------------------------------------------------|-------------------------------------------------------------------------------------------------------------------------------------------------------------------------------------------------------------------------------------------------------------------------------------------------------------------------------------------------------------------------------------------------------------------------------------------------------------------------------------------------------------------------------------------------------------------------------------------------------------------------------------------------------------------------------------------------------------------------------------------------------------------------------------------------------------------------------------------|
|                                                                                                                                                     | <p><b>Note:</b> In a "twin-tailed" configuration where there is more than one initiator device (normally another system) attached to the SCSI bus, it may be necessary to use SMS utilities to change the ID of the SCSI controller or adapter.</p>                                                                                                                                                                                                                                                                                                                                                                                                                                                                                                                                                                                       |
| You suspect a cable problem.                                                                                                                        | <p>Go to <a href="#">Adapters, Devices and Cables for Multiple Bus Systems</a>.</p> <p><b>Note:</b> The above link will take you to the home page of the ESCALA PL Series and Hypertext Documentation Library. To access the document mentioned above, do the following:</p> <ol style="list-style-type: none"> <li>1. Select the continent (for example, North America)</li> <li>2. Select one of the three languages listed from the AIX listing (for example, English)</li> <li>3. Select "Hardware Documentation" from the navigation bar, located on the left side of the screen.</li> <li>4. In the "Hardware Documentation" window, go to the "general service documentation" section and select "Adapters, Devices, and Cable".</li> <li>5. Select "Adapters, Devices and Cable Information for Multiple Bus Systems."</li> </ol> |
| You have a problem that does not prevent the system from booting. The operator panel is functional and the rack indicator LED operates as expected. | Go to <a href="#">MAP 0020: Problem determination procedure</a> .                                                                                                                                                                                                                                                                                                                                                                                                                                                                                                                                                                                                                                                                                                                                                                         |
| All other symptoms.                                                                                                                                 | Go to <a href="#">MAP 0020: Problem determination procedure</a> .                                                                                                                                                                                                                                                                                                                                                                                                                                                                                                                                                                                                                                                                                                                                                                         |
| All other problems.                                                                                                                                 | Go to <a href="#">MAP 0020: Problem determination procedure</a> .                                                                                                                                                                                                                                                                                                                                                                                                                                                                                                                                                                                                                                                                                                                                                                         |
| You do not have a symptom.                                                                                                                          | Go to <a href="#">MAP 0020: Problem determination procedure</a> .                                                                                                                                                                                                                                                                                                                                                                                                                                                                                                                                                                                                                                                                                                                                                                         |
| You have parts to exchange or a corrective action to perform.                                                                                       | <ol style="list-style-type: none"> <li>1. Go to <a href="#">Start of call procedure</a>.</li> <li>2. Go to <a href="#">End of call procedure</a>.</li> </ol>                                                                                                                                                                                                                                                                                                                                                                                                                                                                                                                                                                                                                                                                              |
| You need to verify that a part exchange or corrective action corrected the problem.                                                                 | Go to <a href="#">MAP 0410: Repair checkout</a> .                                                                                                                                                                                                                                                                                                                                                                                                                                                                                                                                                                                                                                                                                                                                                                                         |
| You need to verify correct system operation.                                                                                                        | Go to <a href="#">MAP 0410: Repair checkout</a> .                                                                                                                                                                                                                                                                                                                                                                                                                                                                                                                                                                                                                                                                                                                                                                                         |
| The system stopped. A POST indicator is displayed on the system console and an eight-digit error code is not displayed.                             | <p>If the POST indicator represents:</p> <ol style="list-style-type: none"> <li>1. Memory, go to <a href="#">PFW1548: Memory and processor subsystem problem isolation procedure</a>.</li> <li>2. Keyboard <ol style="list-style-type: none"> <li>a. Replace the keyboard.</li> <li>b. Replace the service processor, location: model dependent.</li> </ol> </li> </ol>                                                                                                                                                                                                                                                                                                                                                                                                                                                                   |

|                                                                                                                 |                                                                                                                                                                                                                                                                                                                                                                                                                                                                                                                                                                                                                                                                                                                                                                                                                                                                                                                                                                                                                                                                                                                     |
|-----------------------------------------------------------------------------------------------------------------|---------------------------------------------------------------------------------------------------------------------------------------------------------------------------------------------------------------------------------------------------------------------------------------------------------------------------------------------------------------------------------------------------------------------------------------------------------------------------------------------------------------------------------------------------------------------------------------------------------------------------------------------------------------------------------------------------------------------------------------------------------------------------------------------------------------------------------------------------------------------------------------------------------------------------------------------------------------------------------------------------------------------------------------------------------------------------------------------------------------------|
|                                                                                                                 | <p>c. Go to <a href="#">PFW1548: Memory and processor subsystem problem isolation procedure</a>.</p> <p>3. Network, go to <a href="#">PFW1548: Memory and processor subsystem problem isolation procedure</a>.</p> <p>4. SCSI, go to <a href="#">PFW1548: Memory and processor subsystem problem isolation procedure</a>.</p> <p>5. Speaker</p> <p>a. Replace the control panel. The location is model dependent; refer to <a href="#">Installing features</a></p> <p>b. Replace the service processor. The location is model dependent.</p> <p>c. Go to <a href="#">PFW1548: Memory and processor subsystem problem isolation procedure</a>.</p>                                                                                                                                                                                                                                                                                                                                                                                                                                                                   |
| The diagnostic operating instructions are displayed.                                                            | Go to <a href="#">MAP 0020: Problem determination procedure</a> .                                                                                                                                                                                                                                                                                                                                                                                                                                                                                                                                                                                                                                                                                                                                                                                                                                                                                                                                                                                                                                                   |
| The system login prompt is displayed.                                                                           | <p>If you are loading the diagnostics from a CD-ROM, you may not have pressed the correct key or you may not have pressed the key soon enough when you were trying to indicate a service mode IPL of the diagnostic programs. If this is the case, try to boot the CD-ROM again and press the correct key.</p> <p><b>Note:</b> Perform the system shutdown procedure before turning off the system.</p> <p>If you are sure you pressed the correct key in a timely manner, go to <a href="#">Step 1020-2</a>.</p> <p>If you are loading diagnostics from a Network Installation Management (NIM) server, check for the following:</p> <ul style="list-style-type: none"> <li>• The bootlist on the client may be incorrect.</li> <li>• Cstate on the NIM server may be incorrect.</li> <li>• There may be network problems preventing you from connecting to the NIM server.</li> </ul> <p>Verify the settings and the status of the network. If you continue to have problems refer to <a href="#">Problems with loading and starting the operating system</a> and follow the steps for network boot problems.</p> |
| The System Management Services (SMS) menu is displayed when you were trying to boot standalone AIX diagnostics. | If you are loading diagnostics from the CD-ROM, you may not have pressed the correct key when you were trying to indicate a service mode IPL of the diagnostic programs. If this is the case, try to boot the CD-ROM again and press the correct key.                                                                                                                                                                                                                                                                                                                                                                                                                                                                                                                                                                                                                                                                                                                                                                                                                                                               |

|                                                                                                                                      |                                                                                                                                                                                                                                                                                                                                                                                                                                                                                                                                                                                                                                                         |
|--------------------------------------------------------------------------------------------------------------------------------------|---------------------------------------------------------------------------------------------------------------------------------------------------------------------------------------------------------------------------------------------------------------------------------------------------------------------------------------------------------------------------------------------------------------------------------------------------------------------------------------------------------------------------------------------------------------------------------------------------------------------------------------------------------|
|                                                                                                                                      | <p>If you are sure you pressed the correct key, the device or media you are attempting to boot from may be faulty.</p> <ol style="list-style-type: none"> <li>1. Try to boot from an alternate boot device connected to the same controller as the original boot device. If the boot succeeds, replace the original boot device (for removable media devices, try the media first).</li> </ol> <p>If the boot fails, go to <a href="#">Problems with loading and starting the operating system</a>.</p> <ol style="list-style-type: none"> <li>2. Go to <a href="#">PFW1548: Memory and processor subsystem problem isolation procedure</a>.</li> </ol> |
| <p>The SMS boot sequence selection menu or remote IPL menu does not show all of the bootable devices in the partition or system.</p> | <p>If an AIX or Linux partition is being booted, verify that the devices that you expect to see in the list are assigned to this partition. If they are not, use the HMC to reassign the required resources. If they are assigned to this partition, go to <a href="#">Problems with loading and starting the operating system</a> to resolve the problem.</p>                                                                                                                                                                                                                                                                                          |

## Linux server or Linux partition symptoms

Use the following tables to find the symptom you are experiencing. If you cannot find your symptom, contact your next level of support.

Choose the description that best describes your situation:

- [You have a service action to perform](#)
- [Integrated Virtualization Manager \(IVM\) Problem](#)
- [An LED is not operating as expected](#)
- [Control \(operator\) panel problems](#)
- [Reference codes](#)
- [Hardware Management Console \(HMC\) Problem](#)
- [There is a display or monitor problem \(for example, distortion or blurring\)](#)
- [Power and cooling problems](#)
- [Other symptoms or problems](#)

### You have a service action to perform

| Symptom                                                                             | What you should do:                                                                                                                                                   |
|-------------------------------------------------------------------------------------|-----------------------------------------------------------------------------------------------------------------------------------------------------------------------|
| You have an open service event in the service action event log.                     | Go to <a href="#">Start of call procedure</a> .                                                                                                                       |
| You have parts to exchange or a corrective action to perform.                       | <ol style="list-style-type: none"> <li>1. Go to <a href="#">Removing and replacing parts</a>.</li> <li>2. Go to <a href="#">the End-of-call procedure</a>.</li> </ol> |
| You need to verify that a part exchange or corrective action corrected the problem. | <ol style="list-style-type: none"> <li>1. Go to <a href="#">Verifying the repair</a>.</li> </ol>                                                                      |



|                                              |                                                                                                         |
|----------------------------------------------|---------------------------------------------------------------------------------------------------------|
|                                              | 2. Go to the <a href="#">End-of-call procedure</a> .                                                    |
| You need to verify correct system operation. | 1. Go to <a href="#">Verifying the repair</a> .<br>2. Go to the <a href="#">End-of-call procedure</a> . |

### Integrated Virtualization Manager (IVM) Problem

| Symptom                                                             | What you should do:                                                                                             |
|---------------------------------------------------------------------|-----------------------------------------------------------------------------------------------------------------|
| The partitions do not activate - partition configuration is damaged | Restore the partition configuration data using IVM. See <a href="#">Backing up and restoring partition data</a> |
| Other partition problems when the server is managed by IVM          | Perform <a href="#">Troubleshooting with the Integrated Virtualization Manager</a>                              |

### An LED is not operating as expected

| Symptom                                                                   | What you should do:                                                                                                                                                                                                                                                                                                                                                                                                                                                                                                |
|---------------------------------------------------------------------------|--------------------------------------------------------------------------------------------------------------------------------------------------------------------------------------------------------------------------------------------------------------------------------------------------------------------------------------------------------------------------------------------------------------------------------------------------------------------------------------------------------------------|
| The system attention LED on the control panel is on.                      | Go to <a href="#">Linux fast-path problem isolation</a> .                                                                                                                                                                                                                                                                                                                                                                                                                                                          |
| The rack identify LED does not operate properly.                          | Go to the <a href="#">Linux fast-path problem isolation</a> .                                                                                                                                                                                                                                                                                                                                                                                                                                                      |
| The rack indicator LED does not turn on, but a drawer identify LED is on. | <ol style="list-style-type: none"> <li>1. Make sure the rack indicator LED is properly mounted to the rack.</li> <li>2. Make sure that the rack identify LED is properly cabled to the bus bar on the rack and to the drawer identify LED connector.</li> <li>3. Replace the following parts one at a time: <ul style="list-style-type: none"> <li>◆ Rack LED to bus bar cable</li> <li>◆ LED bus bar to drawer cable</li> <li>◆ LED bus bar</li> </ul> </li> <li>4. Contact your next level of support</li> </ol> |

### Control (operator) panel problems

| Symptom                                                                                                | What you should do:                    |
|--------------------------------------------------------------------------------------------------------|----------------------------------------|
| 01 does not appear in the upper-left corner of the operator panel display after the power is connected | Go to <a href="#">Power problems</a> . |

|                                                                                                                                             |                                                                                                                                                                                                                                                                                                                                                                                                                                                                                                                                                                                                                                                                                                                                                                                                                                                                                                                                                                                                                                                                                                                                                                                                                                                                                                                                   |
|---------------------------------------------------------------------------------------------------------------------------------------------|-----------------------------------------------------------------------------------------------------------------------------------------------------------------------------------------------------------------------------------------------------------------------------------------------------------------------------------------------------------------------------------------------------------------------------------------------------------------------------------------------------------------------------------------------------------------------------------------------------------------------------------------------------------------------------------------------------------------------------------------------------------------------------------------------------------------------------------------------------------------------------------------------------------------------------------------------------------------------------------------------------------------------------------------------------------------------------------------------------------------------------------------------------------------------------------------------------------------------------------------------------------------------------------------------------------------------------------|
| and before pressing the power-on button. Other symptoms appear in the operator panel display or LEDs before the power on button is pressed. |                                                                                                                                                                                                                                                                                                                                                                                                                                                                                                                                                                                                                                                                                                                                                                                                                                                                                                                                                                                                                                                                                                                                                                                                                                                                                                                                   |
| A bouncing or scrolling ball remains on the operator panel display, or the operator panel display is filled with dashes or blocks.          | <p>Verify that the operator panel connections to the system backplane are connected and properly seated.</p> <p>If a client computer (such as a PC with Ethernet capability and a Web browser) is available, connect it to the service processor in the server that is displaying the symptom.</p> <p>To connect a personal computer with Ethernet capability and a Web browser, or an ASCII terminal, to access the Advanced System Management Interface (ASMI), go to <a href="#">Managing your server using the Advanced System Management Interface</a>.</p> <ul style="list-style-type: none"> <li>• If you can successfully access the ASMI, replace the operator panel assembly. Refer to <a href="#">Finding part locations</a> to determine the part number and correct exchange procedure.</li> <li>• If you cannot successfully access the ASMI, replace the service processor. Refer to <a href="#">Finding part locations</a> to determine the part number and correct exchange procedure.</li> </ul> <p>If you do not have a PC or ASCII terminal, replace the following one at a time (go to <a href="#">Finding part locations</a> to determine the part number and correct exchange procedure):</p> <ol style="list-style-type: none"> <li>1. Operator panel assembly.</li> <li>2. Service processor.</li> </ol> |
| You have a blank display on the operator panel. Other LEDs on the operator panel appear to behave normally.                                 | <ol style="list-style-type: none"> <li>1. Replace the operator panel assembly. Refer to <a href="#">Removing and replacing parts</a>.</li> <li>2. Replace the service processor. Refer to <a href="#">Removing and replacing parts</a>.</li> </ol>                                                                                                                                                                                                                                                                                                                                                                                                                                                                                                                                                                                                                                                                                                                                                                                                                                                                                                                                                                                                                                                                                |
| You have a blank display on the operator panel. Other LEDs on the operator panel are off.                                                   | Go to <a href="#">Power problems</a> .                                                                                                                                                                                                                                                                                                                                                                                                                                                                                                                                                                                                                                                                                                                                                                                                                                                                                                                                                                                                                                                                                                                                                                                                                                                                                            |

## Reference codes

| <b>Symptom</b>                            | <b>What you should do:</b>                                                                                                                                                                                                                                                                                                                                                                                                                                                                                                         |
|-------------------------------------------|------------------------------------------------------------------------------------------------------------------------------------------------------------------------------------------------------------------------------------------------------------------------------------------------------------------------------------------------------------------------------------------------------------------------------------------------------------------------------------------------------------------------------------|
| You have an 8-digit error code displayed. | <p>Look up the reference code in the <a href="#">Reference codes</a> section of the ESCALA Power5 Hardware Information.</p> <p><b>Note:</b> If the repair for this code does not involve replacing a FRU (for instance, running an AIX command that fixes the problem or changing a hot-pluggable FRU), then update the AIX error log after the problem is resolved by performing the following steps:</p> <ol style="list-style-type: none"> <li>1. In the online diagnostics, select Task SelectionLog Repair Action.</li> </ol> |

|                                                                                                                                       |                                                                                                                                                                                                                                                                                                                                                                                                                                                                                                                                                                                                                                                                                                                                                                                                                                                                                                                                                                                                                                       |
|---------------------------------------------------------------------------------------------------------------------------------------|---------------------------------------------------------------------------------------------------------------------------------------------------------------------------------------------------------------------------------------------------------------------------------------------------------------------------------------------------------------------------------------------------------------------------------------------------------------------------------------------------------------------------------------------------------------------------------------------------------------------------------------------------------------------------------------------------------------------------------------------------------------------------------------------------------------------------------------------------------------------------------------------------------------------------------------------------------------------------------------------------------------------------------------|
|                                                                                                                                       | <p>2. Select resource sysplanar0.</p> <p>On systems with a fault indicator LED, this changes the "fault indicator" LED from the "fault" state to the "normal" state.</p>                                                                                                                                                                                                                                                                                                                                                                                                                                                                                                                                                                                                                                                                                                                                                                                                                                                              |
| The system stops with an 8-digit error code displayed when booting.                                                                   | Look up the reference code in the <a href="#">Reference codes</a> section of the ESCALA Power5 Hardware Information.                                                                                                                                                                                                                                                                                                                                                                                                                                                                                                                                                                                                                                                                                                                                                                                                                                                                                                                  |
| The system stops and a 4-digit code displays on the control panel that does not begin with 0 or 2.                                    | Look up the reference code in the <a href="#">Reference codes</a> section of the ESCALA Power5 Hardware Information.                                                                                                                                                                                                                                                                                                                                                                                                                                                                                                                                                                                                                                                                                                                                                                                                                                                                                                                  |
| The system stops and a 4-digit code displays on the control panel that begins with 0 or 2 is displayed in the operator panel display. | Record SRN 101-xxxx where xxxx is the 4-digit code displayed in the control panel, then look up this reference code in the <a href="#">Reference codes</a> section of the ESCALA Power5 Hardware Information. Follow the instructions given in the Description and Action column for your SRN.                                                                                                                                                                                                                                                                                                                                                                                                                                                                                                                                                                                                                                                                                                                                        |
| The system stops and a 3-digit number displays on the control panel.                                                                  | <p>Add 101 to the left of the three digits to create an SRN, then look up this reference code in the <a href="#">Reference codes</a> section of the ESCALA Power5 Hardware Information. Follow the instructions given in the Description and Action column for your SRN.</p> <p>If there is a location code displayed under the 3-digit error code, look at the location to see if it matches the failing component that the SRN pointed to. If they do not match, perform the action given in the error code table. If the problem still exists, then replace the failing component from the location code.</p> <p>If there is a location code displayed under the 3-digit error code, record the location code.</p> <p>Record SRN 101-xxx, where xxx is the 3-digit number displayed in the operator panel display, then look up this reference code in the <a href="#">Reference codes</a> section of the ESCALA Power5 Hardware Information. Follow the instructions given in the Description and Action column for your SRN.</p> |

## Hardware Management Console (HMC) Problem

| Symptom                                                                                                                          | What you should do:                                                                                                                                                                                                                                                                                                                                                                                                                                                                                                                                                                                                                                                                                |
|----------------------------------------------------------------------------------------------------------------------------------|----------------------------------------------------------------------------------------------------------------------------------------------------------------------------------------------------------------------------------------------------------------------------------------------------------------------------------------------------------------------------------------------------------------------------------------------------------------------------------------------------------------------------------------------------------------------------------------------------------------------------------------------------------------------------------------------------|
| Hardware Management Console (HMC) cannot be used to manage a managed system, or the connection to the managed system is failing. | <p>If the managed system is operating normally (no error codes or other symptoms), the HMC might have a problem, or the connection to the managed system might be damaged or incorrectly cabled. Do the following:</p> <ol style="list-style-type: none"> <li>1. Check the connections between the HMC and the managed system. Correct any cabling errors if found. If another cable is available, connect it in place of the existing cables and refresh the HMC interface. You may have to wait up to 30 seconds for the managed system to reconnect.</li> <li>2. Verify that any connected HMC is connected to the managed system by checking the Management Environment of the HMC.</li> </ol> |

|                                                                                                                      |                                                                                                                                                                                                                                                                                                                                                                                                                                                                                                                                                                                                                                                                                                                                                                                                                                                                                                                                                                                                                                     |
|----------------------------------------------------------------------------------------------------------------------|-------------------------------------------------------------------------------------------------------------------------------------------------------------------------------------------------------------------------------------------------------------------------------------------------------------------------------------------------------------------------------------------------------------------------------------------------------------------------------------------------------------------------------------------------------------------------------------------------------------------------------------------------------------------------------------------------------------------------------------------------------------------------------------------------------------------------------------------------------------------------------------------------------------------------------------------------------------------------------------------------------------------------------------|
|                                                                                                                      | <p><b>Note:</b> The managed system must have power connected and the system running, or waiting for a power-on instruction (01 is in the upper-left corner of the operator panel.)</p> <p>If the managed system does not appear in the Navigation area of the HMC Management Environment, the HMC or the connection to the managed system might be failing.</p> <ol style="list-style-type: none"> <li>3. Go to the <a href="#">Managing your server using the Hardware Management Console</a> section.</li> <li>4. There might be a problem with the service processor card or the HMC system backplane. If you cannot fix the problem using the HMC tests in the <a href="#">Managing your server using the Hardware Management Console</a> section:             <ol style="list-style-type: none"> <li>a. Replace the service processor card. Refer to <a href="#">Removing and replacing parts</a>.</li> <li>b. Replace the HMC system backplane. Refer to <a href="#">Removing and replacing parts</a>.</li> </ol> </li> </ol> |
| <p>Hardware Management Console (HMC) cannot call out using the attached modem and the customer's telephone line.</p> | <p>If the managed system is operating normally (no error codes or other symptoms), the HMC might have a problem, or the connection to the modem and telephone line might have a problem. Do the following:</p> <ol style="list-style-type: none"> <li>1. Check the connections between the HMC and the modem and telephone line. Correct any cabling errors if found.</li> <li>2. Go to the <a href="#">Managing your server using the Hardware Management Console</a> for information about the HMC.</li> </ol>                                                                                                                                                                                                                                                                                                                                                                                                                                                                                                                    |

**There is a display problem (for example, distortion or blurring)**

| Symptom                      | What you should do:                                                                                                                                                                                                                                                                                                                                                                                                                                                                                                                                                                                                                                                                                                                         |
|------------------------------|---------------------------------------------------------------------------------------------------------------------------------------------------------------------------------------------------------------------------------------------------------------------------------------------------------------------------------------------------------------------------------------------------------------------------------------------------------------------------------------------------------------------------------------------------------------------------------------------------------------------------------------------------------------------------------------------------------------------------------------------|
| <p>All display problems.</p> | <ol style="list-style-type: none"> <li>1. If you are using the Hardware Management Console, go to the <a href="#">Managing your server using the Hardware Management Console</a> section.</li> <li>2. If you are using a graphics display:             <ol style="list-style-type: none"> <li>a. Go to the problem determination procedures for the display.</li> <li>b. If you do not find a problem:                 <ul style="list-style-type: none"> <li>◇ Replace the graphics display adapter. Refer to <a href="#">Removing and replacing parts</a>.</li> <li>◇ Replace the backplane into which the graphics display adapter is plugged. Refer to <a href="#">Removing and replacing parts</a>.</li> </ul> </li> </ol> </li> </ol> |

|                                                                         |                                                             |
|-------------------------------------------------------------------------|-------------------------------------------------------------|
| There appears to be a display problem (distortion, blurring, and so on) | Go to the problem determination procedures for the display. |
|-------------------------------------------------------------------------|-------------------------------------------------------------|

## Power and cooling problems

| Symptom                                                                                                          | What you should do:                                                                                                                           |
|------------------------------------------------------------------------------------------------------------------|-----------------------------------------------------------------------------------------------------------------------------------------------|
| The system will not power on and no error codes are available.                                                   | Go to <a href="#">Power problems</a> .                                                                                                        |
| The power LEDs on the operator panel and the power supply do not come on or stay on.                             | <ol style="list-style-type: none"> <li>1. Check the service processor error log.</li> <li>2. Go to <a href="#">Power problems</a>.</li> </ol> |
| The power LEDs on the operator panel and the power supply come on and stay on, but the system does not power on. | <ol style="list-style-type: none"> <li>1. Check the service processor error log.</li> <li>2. Go to <a href="#">Power problems</a>.</li> </ol> |
| A rack or a rack-mounted unit will not power on.                                                                 | <ol style="list-style-type: none"> <li>1. Check the service processor error log.</li> <li>2. Go to <a href="#">Power problems</a>.</li> </ol> |
| The cooling fan(s) do not come on, or come on but do not stay on.                                                | <ol style="list-style-type: none"> <li>1. Check the service processor error log.</li> <li>2. Go to <a href="#">Power problems</a>.</li> </ol> |
| The system attention LED on the operator panel is on and there is no error code displayed.                       | <ol style="list-style-type: none"> <li>1. Check the service processor error log.</li> <li>2. Go to <a href="#">Power problems</a>.</li> </ol> |

## Other symptoms or problems

| Symptom                                                                              | What you should do:                                                                                                                                                                                                                                                                                 |
|--------------------------------------------------------------------------------------|-----------------------------------------------------------------------------------------------------------------------------------------------------------------------------------------------------------------------------------------------------------------------------------------------------|
| The system stopped and a code is displayed on the operator panel.                    | Go to <a href="#">Start of call procedure</a> .                                                                                                                                                                                                                                                     |
| 01 is displayed in the upper-left corner of the operator panel and the fans are off. | The service processor is ready. The system is waiting for power-on. Boot the system. If the boot is unsuccessful, and the system returns to the default display (indicated by 01 in the upper-left corner of the operator panel), go to <a href="#">MAP 0020: Problem determination procedure</a> . |
| The operator panel displays STBY.                                                    |                                                                                                                                                                                                                                                                                                     |

|                                                                                                                                                                                                                                                                                                                                                                                         |                                                                                                                                                                                                                                                                                                                                                                                                                                                                                                                                                                                                    |
|-----------------------------------------------------------------------------------------------------------------------------------------------------------------------------------------------------------------------------------------------------------------------------------------------------------------------------------------------------------------------------------------|----------------------------------------------------------------------------------------------------------------------------------------------------------------------------------------------------------------------------------------------------------------------------------------------------------------------------------------------------------------------------------------------------------------------------------------------------------------------------------------------------------------------------------------------------------------------------------------------------|
|                                                                                                                                                                                                                                                                                                                                                                                         | <p>The service processor is ready. The server was shut down by the operating system and is still powered on. This condition can be requested by a privileged system user with no faults. Go to <a href="#">Start-of-call</a>.</p> <p><b>Note:</b> See the service processor error log for possible operating system fault indications.</p>                                                                                                                                                                                                                                                         |
| <p>All of the system POST indicators are displayed on the firmware console, the system pauses and then restarts. The term <i>POST indicators</i> refers to the device mnemonics (the words <code>memory</code>, <code>keyboard</code>, <code>network</code>, <code>scsi</code>, and <code>speaker</code>) that appear on the firmware console during the power-on self-test (POST).</p> | <p>Go to <a href="#">Problems with loading and starting the operating system</a>.</p>                                                                                                                                                                                                                                                                                                                                                                                                                                                                                                              |
| <p>The system stops and all of the POST indicators are displayed on the firmware console. The term <i>POST indicators</i> refers to the device mnemonics (the words <code>memory</code>, <code>keyboard</code>, <code>network</code>, <code>scsi</code>, and <code>speaker</code>) that appear on the firmware console during the power-on self-test (POST).</p>                        | <p>Go to <a href="#">Problems with loading and starting the operating system</a>.</p>                                                                                                                                                                                                                                                                                                                                                                                                                                                                                                              |
| <p>The system stops and the message <code>starting software please wait...</code> is displayed on the firmware console.</p>                                                                                                                                                                                                                                                             | <p>Go to <a href="#">Problems with loading and starting the operating system</a>.</p>                                                                                                                                                                                                                                                                                                                                                                                                                                                                                                              |
| <p>The system does not respond to the password being entered or the system login prompt is displayed when booting in service mode.</p>                                                                                                                                                                                                                                                  | <ol style="list-style-type: none"> <li>1. If the password is being entered from the Hardware Management Console (HMC), go to the <a href="#">Managing your server using the Hardware Management Console</a>.</li> <li>2. If the password is being entered from a keyboard attached to the system, the keyboard or its controller may be faulty. In this case, replace these parts in the following order: <ol style="list-style-type: none"> <li>a. Keyboard</li> <li>b. Service processor</li> </ol> </li> </ol> <p>If the problem is fixed, go to <a href="#">MAP 0410: Repair checkout</a>.</p> |
| <p>The system stops with a prompt to enter a password.</p>                                                                                                                                                                                                                                                                                                                              | <p>Enter the password. You cannot continue until a correct password has been entered. When you have entered a valid password, go to the beginning of this table and wait for one of the other conditions to occur.</p>                                                                                                                                                                                                                                                                                                                                                                             |
| <p>The system does not respond when the password is entered.</p>                                                                                                                                                                                                                                                                                                                        | <p>Go to <a href="#">Step 1020-2</a>.</p>                                                                                                                                                                                                                                                                                                                                                                                                                                                                                                                                                          |
| <p>No codes are displayed on the operator panel within a few seconds of turning on the system. The operator panel is blank before the system is powered on.</p>                                                                                                                                                                                                                         | <p>Reseat the operator panel cable. If the problem is not resolved, replace in the following order:</p> <ol style="list-style-type: none"> <li>1. Operator panel assembly. Refer to <a href="#">Removing and replacing parts</a></li> <li>2. Service processor. Refer to <a href="#">Removing and replacing parts</a>.</li> </ol> <p>If the problem is fixed, go to <a href="#">MAP 0410: Repair checkout</a>.</p> <p>If the problem is still not corrected, go to <a href="#">MAP 0020: Problem determination procedure</a>.</p>                                                                  |
|                                                                                                                                                                                                                                                                                                                                                                                         |                                                                                                                                                                                                                                                                                                                                                                                                                                                                                                                                                                                                    |

|                                                                                                                                                            |                                                                                                                                                                                                                                                                                                                                                                                                                                                                                                                                                                                                                                                                                                                                                                                                                 |
|------------------------------------------------------------------------------------------------------------------------------------------------------------|-----------------------------------------------------------------------------------------------------------------------------------------------------------------------------------------------------------------------------------------------------------------------------------------------------------------------------------------------------------------------------------------------------------------------------------------------------------------------------------------------------------------------------------------------------------------------------------------------------------------------------------------------------------------------------------------------------------------------------------------------------------------------------------------------------------------|
| <p>The SMS configuration list or boot sequence selection menu shows more SCSI devices attached to a controller/adaptor than are actually attached.</p>     | <p>A device may be set to use the same SCSI bus ID as the control adapter. Note the ID being used by the controller/adaptor (this can be checked and/or changed through an SMS utility), and verify that no device attached to the controller is set to use that ID.</p> <p>If settings do not appear to be in conflict:</p> <ol style="list-style-type: none"> <li>1. Go to <a href="#">MAP 0020: Problem determination procedure</a>.</li> <li>2. Replace the SCSI cable.</li> <li>3. Replace the device.</li> <li>4. Replace the SCSI adapter</li> </ol> <p><b>Note:</b> In a "twin-tailed" configuration where there is more than one initiator device (normally another system) attached to the SCSI bus, it may be necessary to use SMS utilities to change the ID of the SCSI controller or adapter.</p> |
| <p>You suspect a cable problem.</p>                                                                                                                        | <p>Go to <a href="#">Adapters, Devices and Cables for Multiple Bus Systems</a>.</p>                                                                                                                                                                                                                                                                                                                                                                                                                                                                                                                                                                                                                                                                                                                             |
| <p>You have a problem that does not prevent the system from booting. The operator panel is functional and the rack indicator LED operates as expected.</p> | <p>Go to <a href="#">MAP 0020: Problem determination procedure</a>.</p>                                                                                                                                                                                                                                                                                                                                                                                                                                                                                                                                                                                                                                                                                                                                         |
| <p>All other symptoms.</p>                                                                                                                                 | <p>Go to <a href="#">MAP 0020: Problem determination procedure</a>.</p>                                                                                                                                                                                                                                                                                                                                                                                                                                                                                                                                                                                                                                                                                                                                         |
| <p>All other problems.</p>                                                                                                                                 | <p>Go to <a href="#">MAP 0020: Problem determination procedure</a>.</p>                                                                                                                                                                                                                                                                                                                                                                                                                                                                                                                                                                                                                                                                                                                                         |
| <p>You do not have a symptom.</p>                                                                                                                          | <p>Go to <a href="#">MAP 0020: Problem determination procedure</a>.</p>                                                                                                                                                                                                                                                                                                                                                                                                                                                                                                                                                                                                                                                                                                                                         |
| <p>You have parts to exchange or a corrective action to perform.</p>                                                                                       | <ol style="list-style-type: none"> <li>1. Go to <a href="#">Start of call procedure</a>.</li> <li>2. Go to <a href="#">End of call procedure</a>.</li> </ol>                                                                                                                                                                                                                                                                                                                                                                                                                                                                                                                                                                                                                                                    |
| <p>You need to verify that a part exchange or corrective action corrected the problem.</p>                                                                 | <p>Go to <a href="#">MAP 0410: Repair checkout</a>.</p>                                                                                                                                                                                                                                                                                                                                                                                                                                                                                                                                                                                                                                                                                                                                                         |
| <p>You need to verify correct system operation.</p>                                                                                                        | <p>Go to <a href="#">MAP 0410: Repair checkout</a>.</p>                                                                                                                                                                                                                                                                                                                                                                                                                                                                                                                                                                                                                                                                                                                                                         |
| <p>The system stopped. A POST indicator is displayed on the system console and an eight-digit error code is not displayed.</p>                             | <p>If the POST indicator represents:</p> <ol style="list-style-type: none"> <li>1. Memory, go to <a href="#">PFW1548: Memory and processor subsystem problem isolation procedure</a>.</li> <li>2. Keyboard <ol style="list-style-type: none"> <li>a. Replace the keyboard.</li> <li>b. Replace the service processor, location: model dependent.</li> <li>c. Go to <a href="#">PFW1548: Memory and processor subsystem problem isolation procedure</a>.</li> </ol> </li> <li>3. Network, go to <a href="#">PFW1548: Memory and processor subsystem problem isolation procedure</a>.</li> <li>4. SCSI, go to <a href="#">PFW1548: Memory and processor subsystem problem isolation procedure</a>.</li> <li>5. Speaker</li> </ol>                                                                                 |

|                                                                                                                    |                                                                                                                                                                                                                                                                                                                                                                                                                                                                                                                                                                                                                                                                                                                                                                                                                                                                                                                                                                                                                                                                                                        |
|--------------------------------------------------------------------------------------------------------------------|--------------------------------------------------------------------------------------------------------------------------------------------------------------------------------------------------------------------------------------------------------------------------------------------------------------------------------------------------------------------------------------------------------------------------------------------------------------------------------------------------------------------------------------------------------------------------------------------------------------------------------------------------------------------------------------------------------------------------------------------------------------------------------------------------------------------------------------------------------------------------------------------------------------------------------------------------------------------------------------------------------------------------------------------------------------------------------------------------------|
|                                                                                                                    | <ul style="list-style-type: none"> <li>a. Replace the control panel. The location is model dependent; refer to <a href="#">Installing features</a></li> <li>b. Replace the service processor. The location is model dependent.</li> <li>c. Go to <a href="#">PFW1548: Memory and processor subsystem problem isolation procedure</a>.</li> </ul>                                                                                                                                                                                                                                                                                                                                                                                                                                                                                                                                                                                                                                                                                                                                                       |
| <p>The diagnostic operating instructions are displayed.</p>                                                        | <p>Go to <a href="#">MAP 0020: Problem determination procedure</a>.</p>                                                                                                                                                                                                                                                                                                                                                                                                                                                                                                                                                                                                                                                                                                                                                                                                                                                                                                                                                                                                                                |
| <p>The system login prompt is displayed.</p>                                                                       | <p>If you are loading the diagnostics from a CD-ROM, you may not have pressed the correct key or you may not have pressed the key soon enough when you were trying to indicate a service mode IPL of the diagnostic programs. If this is the case, start again at the beginning of this step.</p> <p><b>Note:</b> Perform the system shutdown procedure before turning off the system.</p> <p>If you are sure you pressed the correct key in a timely manner, go to <a href="#">Step 1020-2</a>.</p> <p>If you are loading diagnostics from a Network Installation Management (NIM) server, check for the following:</p> <ul style="list-style-type: none"> <li>• The bootlist on the client may be incorrect.</li> <li>• Cstate on the NIM server may be incorrect.</li> <li>• There may be network problems preventing you from connecting to the NIM server.</li> </ul> <p>Verify the settings and the status of the network. If you continue to have problems refer to <a href="#">Problems with loading and starting the operating system</a> and follow the steps for network boot problems.</p> |
| <p>The System Management Services (SMS) menu is displayed when you were trying to boot standalone diagnostics.</p> | <p>If you are loading diagnostics from the CD-ROM, you may not have pressed the correct key when you were trying to indicate a service mode IPL of the diagnostic programs. If this is the case, try to boot the CD-ROM again and press the correct key.</p> <p>If you are sure you pressed the correct key, the device or media you are attempting to boot from may be faulty.</p> <ol style="list-style-type: none"> <li>1. Try to boot from an alternate boot device connected to the same controller as the original boot device. If the boot succeeds, replace the original boot device (for removable media devices, try the media first).</li> </ol>                                                                                                                                                                                                                                                                                                                                                                                                                                            |



|                                                                                                                                      |                                                                                                                                                                                                                                                                                                                                                                |
|--------------------------------------------------------------------------------------------------------------------------------------|----------------------------------------------------------------------------------------------------------------------------------------------------------------------------------------------------------------------------------------------------------------------------------------------------------------------------------------------------------------|
|                                                                                                                                      | <p>If the boot fails, go to problems with loading and starting the operating system.</p> <p>2. Go to <a href="#">PFW1548: Memory and processor subsystem problem isolation procedure</a>.</p>                                                                                                                                                                  |
| <p>The SMS boot sequence selection menu or remote IPL menu does not show all of the bootable devices in the partition or system.</p> | <p>If an AIX or Linux partition is being booted, verify that the devices that you expect to see in the list are assigned to this partition. If they are not, use the HMC to reassign the required resources. If they are assigned to this partition, go to <a href="#">Problems with loading and starting the operating system</a> to resolve the problem.</p> |

## Detecting problems

Provides information on using various tools and techniques to detect and identify problems.

- **Problem determination procedures**  
There are several tools you can use to determine a problem.
- **Problem determination procedure for AIX or Linux servers or partitions**  
This procedure helps to produce or retrieve a service request number (SRN) if the customer or a previous procedure did not provide one.
- **System unit problem determination**  
Use this procedure to obtain a reference code if the customer did not provide you with one, or you are unable to load server diagnostics.
- **Disk-drive-enclosure problem-determination procedures**  
Problem determination procedures are provided by power-on self-tests (POSTs), service request numbers, and maintenance analysis procedures (MAPs). Some of these procedures use the service aids that are described in the user or maintenance information for your system SCSI attachment.

Parent topic: [Service provider information](#)

## Problem determination procedures

There are several tools you can use to determine a problem.

These include:

- **Using the Service Action Log**  
Use this procedure to search for an entry in the Service Action Log (SAL) that matches the time, reference code, or resource of the reported problem.
- **Using the product activity log**  
This procedure can help you learn how to use the Product Activity Log (PAL).
- **Using the problem log**  
Use this procedure to find and analyze a problem log entry that relates to the problem reported.

Parent topic: [Detecting problems](#)

## Using the Service Action Log

Use this procedure to search for an entry in the Service Action Log (SAL) that matches the time, reference code, or resource of the reported problem.

1. On the command line, enter the Start System Service Tools command (`STRSST`). If you cannot get to SST, use function 21 to get to DST (see [Dedicated Service Tools \(DST\)](#)).
2. On the Start Service Tools Sign On display, type in a user ID with QSRV authority and password.

3. Select Start a Service Tool > Hardware Service Manager > Work with service action log.
4. On the Select Timeframe display, change the From: Date and Time to a date and time prior to when the customer reported having the problem.
5. Search for an entry that matches one or more conditions of the problem:
  - ◆ Reference code
  - ◆ Resource
  - ◆ Time
  - ◆ Failing item list
6. Perform the following:
  - ◆ Choose Display the failing item information to display the SAL entry.
  - ◆ Use the Display details option to display part location information.

All new entries in the SAL represent problems that require a service action. It may be necessary to handle any problem in the log even if it does not match the original problem symptom.

The information displayed in the date and time fields are the date and time for the first occurrence of the specific reference code for the resource displayed during the time range selected.

7. Did you find an entry in the SAL?
  - ◆ Yes: Continue with the next step.
  - ◆ No: Is available?
    - ◇ Yes: Go to [Using the problem log](#). This ends the procedure.
    - ◇ No: Go to [Problems with noncritical resources](#). This ends the procedure.
8. Does "See the service information system reference code tables for further problem isolation" appear near the top of the display or are there procedures in the FRU list?
  - ◆ Yes: Perform the following steps:
    - a. Go to the [List of reference codes](#) and use the reference code that is indicated in the log to find the correct reference code table and unit reference code.
    - b. Perform all actions in the Description/Action column before exchanging failing items.

**Note:** When exchanging failing items, the part numbers and locations found in the SAL entry should be used.

This ends the procedure.

- ◆ No: Display the failing item information for the SAL entry. Items at the top of the failing item list are more likely to fix the problem than items at the bottom of the list. Continue with the next step.

#### Notes:

- a. Some failing items are required to be exchanged in groups until the problem is solved.
  - b. Other failing items are flagged as mandatory exchange and must be exchanged before the service action is complete, even if the problem appears to have been repaired.
  - c. Use the "Part Action Code" field in the SAL display to determine if failing items are to be replaced in groups or as mandatory exchanges.
  - d. Unless the "Part Action Code" of a FRU indicates group or mandatory exchange, exchange the failing items one at a time until the problem is repaired. Use the help function to determine the meaning of Part Action Codes.
9. Perform the following steps to help resolve the problem:
    - a. For failing items, refer to [Using failing item codes](#).
    - b. For symbolic FRUs, see [Symbolic FRUs](#).
    - c. To display location information, choose the function key for Additional details. If location information is available, go to [Finding part locations](#) for the model you are working on to determine what removal and replacement procedure to perform. To turn on the failing item's identify light, use the "indicator on" option.

**Note:** In some cases where the failing item does not contain a physical identify light, a higher level identify light will be activated (for example, the planar or unit containing the failing item).

The location information should then be used to locate the actual failing item.

- d. If the failing item is Licensed Internal Code, contact your next level of support for the correct PTF to apply.
10. After exchanging an item, perform the following:
- a. Go to [Verifying the repair](#) and return here.
  - b. If the failing item indicator was turned on during the removal and replacement procedure, use the "indicator off" option to turn off the indicator.
  - c. If all problems have been resolved for the partition, use the "Acknowledge all errors" function at the bottom of the SAL display.
  - d. Close the log entry by selecting Close a NEW entry on the SAL Report display. This ends the procedure.

**Parent topic:** [Problem determination procedures](#)

---

## Finding part locations

Use this information to help you associate a part name, location code, or address with its physical location.

The information in this section provides a cross-reference to help you associate a part name, location code, or address with its physical location. After you determine the part number and location for a part, you can go directly to removal and replacement procedures for the part.

- **[Understanding location codes](#)**

The information provided in this topic defines specific sections of a location code string. Use this topic when you need help in understanding the meaning of a location code.

- **[Locations model ESCALA PL 245T/R](#)**
- **[Locations model ESCALA PL 250R-VL or ESCALA PL 450R-XS](#)**
- **[Locations model ESCALA PL 250R-L, PL 250R-L+ or PL 450R-VL+](#)**
- **[Locations model ESCALA PL 250T/R, PL 250T/R+ or PL 450T/R-L+](#)**

Use this information to help you map a location code to a position on the server for the 112/85, ESCALA PL 250T/R+ or ESCALA PL 450T/R-L+, 9405-520, 9406-520, and ESCALA PL 250T/R models.

- **[Locations model ESCALA PL 450T/R, PL 450T/R+ or PL 850T/R-L+](#)**

Use this information to help you map a location code to a position on the server for the ESCALA PL 450T/R+ or ESCALA PL 850T/R-L+, 9406-550, ESCALA PL 450T/R, models.

- **[Locations model ESCALA PL 1650R-L+ and ESCALA PL 850R/PL 1650R/R+](#)**
- **[Locations model 5/75](#)**
- **[Locations model ESCALA PL 3250R, PL 3250R+, ESCALA PL 6450 or PL 6450R+](#)**

Use this information to help you map a location code to a position on the server for the ESCALA PL 3250R, ESCALA PL 6450R, 9406-595 models, and 5792 racks.

- **[Locations 50/74, 8079-002, and 8093-002 expansion units](#)**
- **[Locations 50/79 expansion unit](#)**
- **[Locations 05/88 and 50/88 expansion units](#)**
- **[Locations 50/94, 52/94, 8094-002, 82/94, and 91/94 expansion unit](#)**
- **[Locations 05/95 and 50/95 expansion units](#)**
- **[Locations 57/86, 57/87, D24, and T24 expansion units](#)**
- **[Locations 57/91, 57/94, and 406/1D expansion units](#)**
- **[Locations 57/95 expansion unit](#)**
- **[Locations 11D/10, 11D/11, and 57/90 expansion units](#)**
- **[Locations 11D/20 expansion unit](#)**

**Parent topic:** [Locating and exchanging parts](#)

### Related information

[Load source placement rules for logical partitions](#)

[Alternate restart device \(IPL\) placement rules for logical partitions](#)

---

## Understanding location codes

The information provided in this topic defines specific sections of a location code string. Use this topic when you need help in understanding the meaning of a location code.

Use the following table to link to a specific topic that you need additional information on when reading your location code.

| Location code topics that might be of interest | Description                                                                                                                                                                                                                                                                                                                                                                                         |
|------------------------------------------------|-----------------------------------------------------------------------------------------------------------------------------------------------------------------------------------------------------------------------------------------------------------------------------------------------------------------------------------------------------------------------------------------------------|
| <a href="#">Location code overview</a>         | Contains background information on the use of location codes.                                                                                                                                                                                                                                                                                                                                       |
| <a href="#">Physical location codes</a>        | Provides a definition for physical location code.                                                                                                                                                                                                                                                                                                                                                   |
| <a href="#">Logical location codes</a>         | Provides a definition of what a logical location code is.                                                                                                                                                                                                                                                                                                                                           |
| <a href="#">Location code format</a>           | Provides descriptive information of the <i>Un</i> value in the location code string. For example U7879.001.                                                                                                                                                                                                                                                                                         |
| <a href="#">Location code labels</a>           | Provides a table that identifies and defines the location code labels. The location code labels begin with an alpha character and follow the system serial number. For example, U7879.001.10ABCDE-P3-C31-T2-L23. (The system serial number is the "10ABCDE" in the previous example.) The P3, C31, T2, and L23 all contain an alpha character that is identified in the Location code labels table. |
| <a href="#">Worldwide unique identifier</a>    | Provides a definition for the world unique identifier. This group of digits follows the resource code labels and always begins with the letter <i>W</i> .                                                                                                                                                                                                                                           |

### Location code overview

Servers (system unit and expansion units) use [physical location codes](#) to provide mapping of replaceable units. Location codes are produced by the server's firmware, which structures them so that they can be used to identify specific parts in a system. The [location code format](#) is the same for all servers.

If you are working with a specific location code, the unit type and model immediately follow the first character (Uttt.mmm). Match the unit type and model to a link, as shown in the Unit type and locations table.

If the location code ends with -Txx-Lxx, the server's firmware could not identify the physical location. When a physical location cannot be identified, a [logical location code](#) is provided. Where logical location codes occur in enclosures, the locations article for the enclosure has the known conversions listed. For logical location codes with no conversion, contact your next level of support.

If the location code begins with UTMPx, the expansion I/O unit's machine type, model and serial number have not been set yet and this is a temporary unit identifier. To identify the unit, examine the display panels on all of the expansion I/O units connected to the server until you find one with the same characters in the first 5 digits of the top line in the unit's display. Record the unit's real machine type and model from the unit label. Match the unit's machine type and model in the Unit type and locations table and follow the link to determine the service information.

**Note:** Locations for units that are not in the preceding list are either not supported or there is a problem in the firmware. Contact your next level of support.

### Physical location codes

Physical location codes provide a mapping of logical functions and components, such as backplanes, removable modules, connectors, ports, cables, and devices, to their specific locations within the physical structure of the server.

### Logical location codes

If the physical location cannot be mapped to a physical location code, the server's firmware will generate a logical location code. A logical location code is a sequence of location labels that identify the path that the system uses to communicate with a given resource.

**Note:** A resource has as many logical location codes as it has logical connections to the system. For example, an external tape device connected to two I/O adapters will have two logical location codes.

An example of a logical location code is:

U7879.001.10ABCDE-P3-C31-T2-L23

The first part of the location code (through the T2 label) represents the physical location code for the resource that communicates with the target resource. The remainder of the logical location code (L23) represents exactly which resource is indicated.

### Location code format

The location code is an alphanumeric string of variable length, consisting of a series of location identifiers, separated by a dash. An example of a physical location for a fan is Un-A1.

The first position, represented by Un (where n is equal to any string contained between the U and the hyphen) in the preceding example, is displayed in one of the following forms:

**Note:** In location codes the U is a constant digit, however the numbered positions following the U are variables and are dependent on your server. Each column defines the numbers following the U in the beginning of the location code.

| Machine type and model number in its location codes             | Feature codes and sequence numbers in its location code            |
|-----------------------------------------------------------------|--------------------------------------------------------------------|
| Utttt.mmm.ssssss-A1                                             | Uffff.ccc.ssssss-A1                                                |
| The leftmost code is always U                                   | The leftmost code is always U                                      |
| tttt represents the unit type of the enclosure (drawer or node) | ffff represents the feature code of the enclosure (drawer or node) |
| mmm represents the model of the enclosure                       | ccc represents the sequence number of the enclosure                |
| ssssss represents the serial number for the enclosure           | ssssss represents the serial number of the enclosure               |

**Note:** The *mmm* or *ccc* number might not be displayed on all location codes for all servers. If the *mmm* value is not displayed, the location code is displayed in one of the following forms:

- *Utttt.ssssss-A1*
- *Uffff.ssssss-A1*

The location code is hierarchical; that is, each location identifier in the string represents a physical part. The order (from left to right), in which each identifier is shown, allows you to determine which parts contain other parts in the string.

The - (dash) separator character represents a relationship between two components in the unit. In the example of the fan, whose location code is *Un-A1*, the - (dash) shows that the fan (A1) is contained in the base unit (or *Un*). Modules, adapters, cables, and devices are all parts that are plugged into another part. Their location codes will always show that they are plugged into another part as components of the server. Another example, *Un-P1-C9* is a memory DIMM, with (C9) plugged into a backplane (P1), which is inside the unit (*Un*).

For more information about the various location code label prefixes, refer to [Location code labels](#).

**Note:** For devices, certain error conditions might cause an device to display the device location in an AIX format.

Table 1. Unit type and locations

| Unit type (Utttt.mmm) | Link to location information                                                            |
|-----------------------|-----------------------------------------------------------------------------------------|
| 0588                  | <a href="#">Locations 05/88 and 50/88 expansion units</a>                               |
| 0595                  | <a href="#">Locations 05/95 and 50/95 expansion units</a>                               |
| 5074                  | <a href="#">Locations 50/74, 8079-002, and 8093-002 expansion units</a>                 |
| 5079                  | <a href="#">Locations 50/79 expansion unit</a>                                          |
| 5088                  | <a href="#">Locations 05/88 and 50/88 expansion units</a>                               |
| 5094                  | <a href="#">Locations 50/94, 52/94, 8094-002, 82/94, and 91/94 expansion unit</a>       |
| 5095                  | <a href="#">Locations 05/95 and 50/95 expansion units</a>                               |
| 5294                  | <a href="#">Locations 50/94, 52/94, 8094-002, 82/94, and 91/94 expansion unit</a>       |
| 5786                  | <a href="#">Locations 57/86, 57/87, D24, and T24 expansion units</a>                    |
| 5787                  | <a href="#">Locations 57/86, 57/87, D24, and T24 expansion units</a>                    |
| 5790                  | <a href="#">Locations 11D/10, 11D/11, and 57/90 expansion units</a>                     |
| 5791                  | <a href="#">Locations 57/91, 57/94, and 406/1D expansion units</a>                      |
| 5794                  | <a href="#">Locations 57/91, 57/94, and 406/1D expansion units</a>                      |
| 7031                  | <a href="#">Locations 57/86, 57/87, D24, and T24 expansion units</a>                    |
| 7040                  | <a href="#">Locations 57/91, 57/94, and 406/1D expansion units</a>                      |
| 7311.D10              | <a href="#">Locations 11D/10, 11D/11, and 57/90 expansion units</a>                     |
| 7311.D11              | <a href="#">Locations 11D/10, 11D/11, and 57/90 expansion units</a>                     |
| 7311.D20              | <a href="#">Locations 11D/20 expansion unit</a>                                         |
| 7879.001              | <a href="#">Locations model ESCALA PL 1650R-L+ and ESCALA PL 850R/PL 1650R/R+</a>       |
| 787A.001              | <a href="#">Locations model ESCALA PL 250T/R, PL 250T/R+ or PL 450T/R-L+</a>            |
| 787B.001              | <a href="#">Locations model ESCALA PL 450T/R, PL 450T/R+ or PL 850T/R-L+</a>            |
| 787C.001              | <a href="#">Locations model ESCALA PL 3250R, PL 3250R+, ESCALA PL 6450 or PL 6450R+</a> |

Service provider information

|          |                                                                                                                              |
|----------|------------------------------------------------------------------------------------------------------------------------------|
| 787D.001 | Locations model 5/75                                                                                                         |
| 787E.001 | Locations model ESCALA PL 250R-L, PL 250R-L+ or PL 450R-VL+                                                                  |
| 787F.001 | Locations model ESCALA PL 250T/R, PL 250T/R+ or PL 450T/R-L+                                                                 |
| 789A.001 | Locations model ESCALA PL 250R-VL or ESCALA PL 450R-XS                                                                       |
| 789B.001 | Locations model ESCALA PL 245T/R                                                                                             |
| 8079     | Locations 50/74, 8079-002, and 8093-002 expansion units                                                                      |
| 8093     | Locations 50/74, 8079-002, and 8093-002 expansion units                                                                      |
| 8094     | Locations 50/94, 52/94, 8094-002, 82/94, and 91/94 expansion unit                                                            |
| 8294     |                                                                                                                              |
| 9194     | Locations 50/94, 52/94, 8094-002, 82/94, and 91/94 expansion unit                                                            |
| 9458.100 | Bulk power assembly (BPA) in Locations model ESCALA PL 3250R, PL 3250R+, ESCALA PL 6450 or PL 6450R+ or Locations model 5/75 |
| tttt.185 | Locations model ESCALA PL 245T/R                                                                                             |
| tttt.285 | Locations model ESCALA PL 250T/R, PL 250T/R+ or PL 450T/R-L+                                                                 |
| tttt.505 | Locations model ESCALA PL 250R-VL or ESCALA PL 450R-XS                                                                       |
| tttt.510 | Locations model ESCALA PL 250R-L, PL 250R-L+ or PL 450R-VL+                                                                  |
| tttt.520 | Locations model ESCALA PL 250T/R, PL 250T/R+ or PL 450T/R-L+                                                                 |
| tttt.52A | Locations model ESCALA PL 250T/R, PL 250T/R+ or PL 450T/R-L+                                                                 |
| tttt.550 | Locations model ESCALA PL 450T/R, PL 450T/R+ or PL 850T/R-L+                                                                 |
| tttt.55A | Locations model ESCALA PL 450T/R, PL 450T/R+ or PL 850T/R-L+                                                                 |
| tttt.561 | Locations model ESCALA PL 1650R-L+ and ESCALA PL 850R/PL 1650R/R+                                                            |
| tttt.570 | Locations model ESCALA PL 1650R-L+ and ESCALA PL 850R/PL 1650R/R+                                                            |
| tttt.575 | Locations model 5/75                                                                                                         |
| tttt.590 | Locations model ESCALA PL 3250R, PL 3250R+, ESCALA PL 6450 or PL 6450R+                                                      |
| tttt.595 | Locations model ESCALA PL 3250R, PL 3250R+, ESCALA PL 6450 or PL 6450R+                                                      |
| tttt.705 | Locations model ESCALA PL 250R-VL or ESCALA PL 450R-XS                                                                       |
| tttt.710 | Locations model ESCALA PL 250R-L, PL 250R-L+ or PL 450R-VL+                                                                  |
| tttt.720 | Locations model ESCALA PL 450T/R, PL 450T/R+ or PL 850T/R-L+                                                                 |
| tttt.A50 | Locations model ESCALA PL 245T/R                                                                                             |

**Location code labels**

The following table explains what the location code label prefixes mean.

**Note:** These labels apply to system units only.

Table 2. Location code label prefixes for system units

| Prefix | Description       | Example                        |
|--------|-------------------|--------------------------------|
| A      | Air-moving device | Fan, blower                    |
| C      | Card connector    | IOP, IOA, DIMM, processor card |
| D      | Device            | Diskette, control panel        |

|   |                                                 |                                   |
|---|-------------------------------------------------|-----------------------------------|
| E | Electrical                                      | Battery, power supply, ac charger |
| L | Logical path SCSI target                        | IDE address, Fibre Channel LUN    |
| N | Horizontal placement for an empty rack location |                                   |
| P | Planar                                          | System backplane                  |
| T | Port                                            |                                   |
| U | Unit                                            |                                   |
| V | Virtual planar                                  |                                   |
| W | Worldwide unique ID                             |                                   |
| X | EIA value for an empty rack location            |                                   |
| Y | Firmware FRU                                    |                                   |

### Worldwide unique identifier

A worldwide unique identifier location label consists of the prefix "W" followed by a maximum of 16 uppercase hexadecimal digits with no leading zeros. A location code may or may not consist of a worldwide unique identifier. When present, the worldwide unique identifier location label follows the location label of the resource that interfaces with the resource having the worldwide unique identifier, usually a port.

Parent topic: [Finding part locations](#)

---

## Locations model 1/85 and ESCALA PL 245T/R

**Note:** The logical location codes for this unit are listed next to the corresponding physical location in the following information. If you are working with a logical location code for this unit and it is not listed in the following information, contact your next level of support.

The following diagrams show field replaceable unit (FRU) layout in the system. Use these diagrams with the following tables to identify parts of the control panel.

The following table provides location codes for parts that make up the server.

**Attention:** After replacing any part on a server or expansion unit, perform [Verifying the repair](#).

*Figure 1. Back view, tower unit*



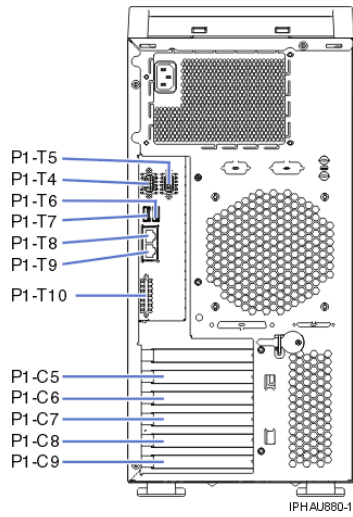


Figure 2. Back view, rack unit

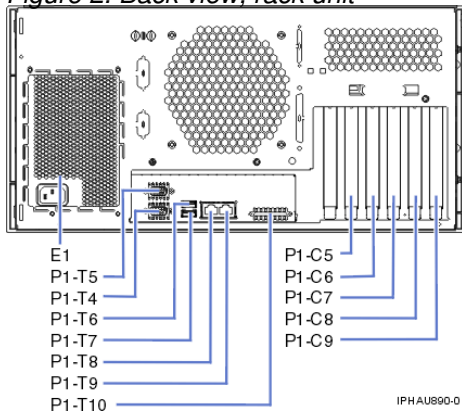


Figure 3. Front view, tower unit

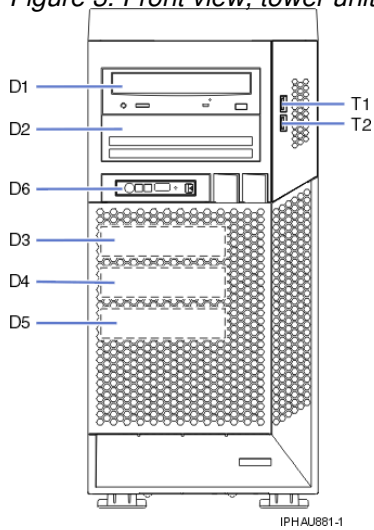


Figure 4. Front view, rack unit

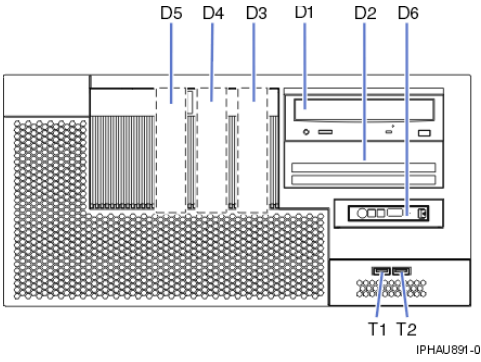


Figure 5. System board view, tower unit

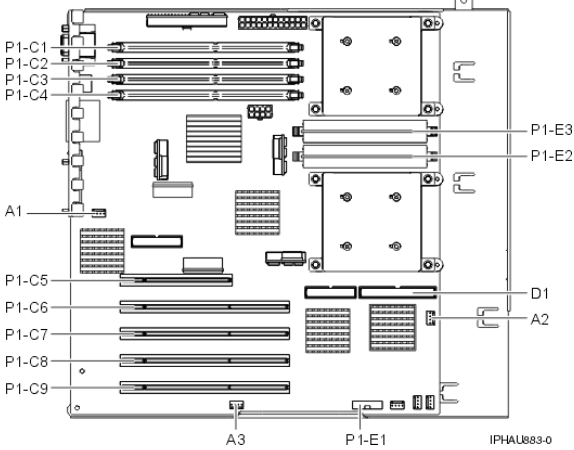


Figure 6. System board view, rack unit

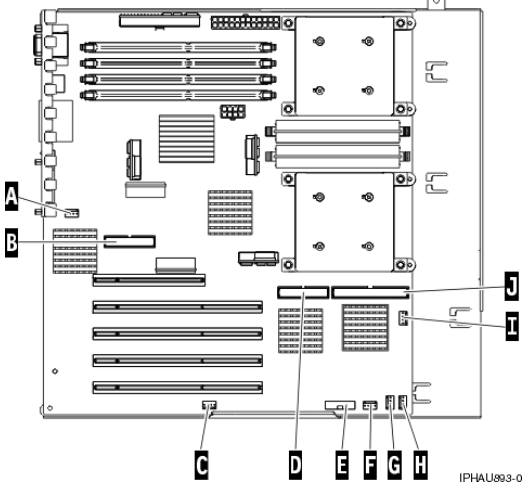


Table 1. FRU locations and failing components

| Failing item name         | Physical location code | Identify LED | Link to part number                    | Failing item removal and replacement procedures |
|---------------------------|------------------------|--------------|----------------------------------------|-------------------------------------------------|
| System unit               | Un                     |              |                                        |                                                 |
| Fans                      |                        |              |                                        |                                                 |
| Fan 1 (Processor cooling) | Un-A1                  | Yes          | <a href="#">Part assembly diagrams</a> | <a href="#">Fans</a>                            |

Service provider information

|                                 |                                                        |     |                                                                                             |                     |
|---------------------------------|--------------------------------------------------------|-----|---------------------------------------------------------------------------------------------|---------------------|
| Fan 2 (Disk drive cooling)      | Un-A2                                                  | Yes | <a href="#">Part assembly diagrams</a>                                                      | Fans                |
| Fan 3 (PCI adapter cooling)     | Un-A3                                                  | Yes | <a href="#">Part assembly diagrams</a>                                                      | Fans                |
| Power supply                    |                                                        |     |                                                                                             |                     |
| Power supply                    | Un-E1                                                  | Yes | <a href="#">Part assembly diagrams</a>                                                      | Power supply        |
| Voltage regulators              |                                                        |     |                                                                                             |                     |
| Voltage-regulator module        | Un-E2                                                  | Yes | Voltage regulator modules are available as part of the <a href="#">System backplane FRU</a> | Voltage regulator   |
| Voltage-regulator module        | Un-E3                                                  | Yes | Voltage regulator modules are available as part of the <a href="#">System backplane FRU</a> | Voltage regulator   |
| Backplane                       |                                                        |     |                                                                                             |                     |
| System backplane                | Un-P1                                                  | Yes | <a href="#">System backplane</a>                                                            | System backplane    |
| NVRAM battery                   | Un-P1-E1                                               |     | <a href="#">Power parts</a>                                                                 | Time-of-day battery |
| Light-path-diagnostic card      | Un-P2                                                  |     |                                                                                             |                     |
| System backplane ports          |                                                        |     |                                                                                             |                     |
| Ethernet port 1 (top)           | Un-P1-T8                                               |     |                                                                                             |                     |
| Ethernet port 2                 | Un-P1-T9                                               |     |                                                                                             |                     |
| External SCSI port              | Un-P1-T10                                              |     |                                                                                             |                     |
| Serial port 1 (left)            | Un-P1-T4                                               |     |                                                                                             |                     |
| Serial port 2                   | Un-P1-T5                                               |     |                                                                                             |                     |
| USB port 1 (left)               | Un-P1-T6                                               |     |                                                                                             |                     |
| USB port 2                      | Un-P1-T7                                               |     |                                                                                             |                     |
| Internal SCSI port              | Un-P1-T11                                              |     |                                                                                             |                     |
| IDE controller port             | Un-P1-T12                                              |     |                                                                                             |                     |
| USB port 3 on front cover (top) | Un-T1                                                  |     |                                                                                             |                     |
| USB port 4 on front cover       | Un-T2                                                  |     |                                                                                             |                     |
| Adapters                        |                                                        |     |                                                                                             |                     |
| PCI adapter in slot 1           | Un-P1-C5                                               | Yes | <a href="#">System parts</a>                                                                | PCI adapter         |
| PCI adapter in slot 2           | Un-P1-C6                                               | Yes | <a href="#">System parts</a>                                                                | PCI adapter         |
| PCI adapter in slot 3           | Un-P1-C7                                               | Yes | <a href="#">System parts</a>                                                                | PCI adapter         |
| PCI adapter in slot 4           | Un-P1-C8                                               | Yes | <a href="#">System parts</a>                                                                | PCI adapter         |
| PCI adapter in slot 5           | Un-P1-C9                                               | Yes | <a href="#">System parts</a>                                                                | PCI adapter         |
| Memory modules                  |                                                        |     |                                                                                             |                     |
| Memory DIMM 1                   | Un-P1-C1                                               | Yes | <a href="#">Memory parts</a>                                                                | Memory modules      |
| Memory DIMM 2                   | Un-P1-C2                                               | Yes | <a href="#">Memory parts</a>                                                                | Memory modules      |
| Memory DIMM 3                   | Un-P1-C3                                               | Yes | <a href="#">Memory parts</a>                                                                | Memory modules      |
| Memory DIMM 4                   | Un-P1-C4                                               | Yes | <a href="#">Memory parts</a>                                                                | Memory modules      |
| Device locations                |                                                        |     |                                                                                             |                     |
| Media device (top)              | Un-D1                                                  | Yes | <a href="#">Removable media device parts</a>                                                |                     |
| Disk drive 1 or media device    | Un-D2<br>(Un-P1-T8-L0-L0 is the logical location code) | Yes | <a href="#">Disk unit parts</a> or <a href="#">Removable media device parts</a>             | Disk drive          |
| Disk drive 2                    |                                                        | Yes | <a href="#">Disk unit parts</a>                                                             | Disk drive          |

Service provider information

|               |                                                              |     |                 |               |
|---------------|--------------------------------------------------------------|-----|-----------------|---------------|
|               | Un-D3<br>(Un-P1-T8-L1-L0<br>is the logical<br>location code) |     |                 |               |
| Disk drive 3  | Un-D4<br>(Un-P1-T8-L2-L0<br>is the logical<br>location code) | Yes | Disk unit parts | Disk drive    |
| Disk drive 4  | Un-D5<br>(Un-P1-T8-L3-L0<br>is the logical<br>location code) | Yes | Disk unit parts | Disk drive    |
| Control panel |                                                              |     |                 |               |
| Control panel | Un-D6                                                        |     |                 | Control panel |

Parent topic: [Finding part locations](#)

## Part assembly diagrams for model 1/85 and ESCALA PL 245T/R

This content covers the ESCALA PL 245T/R models.

### Stand-alone cover assembly for model 1/85

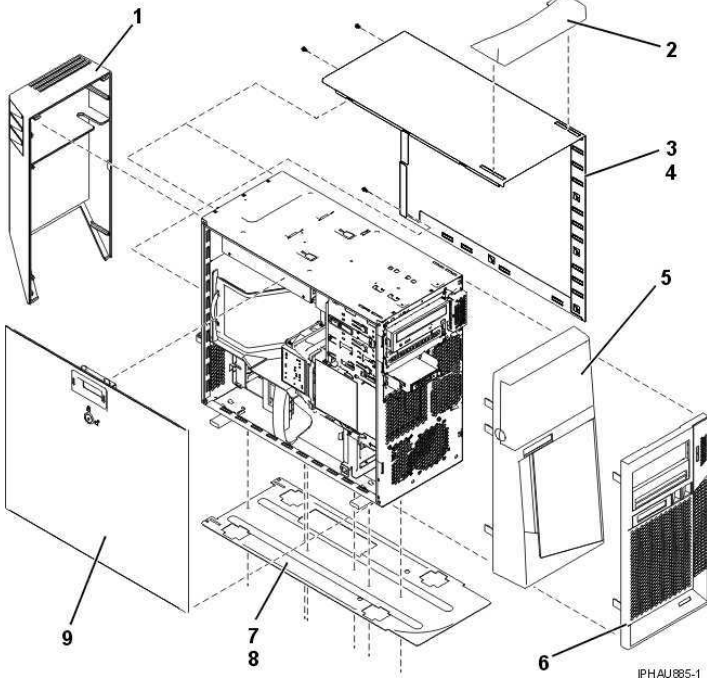


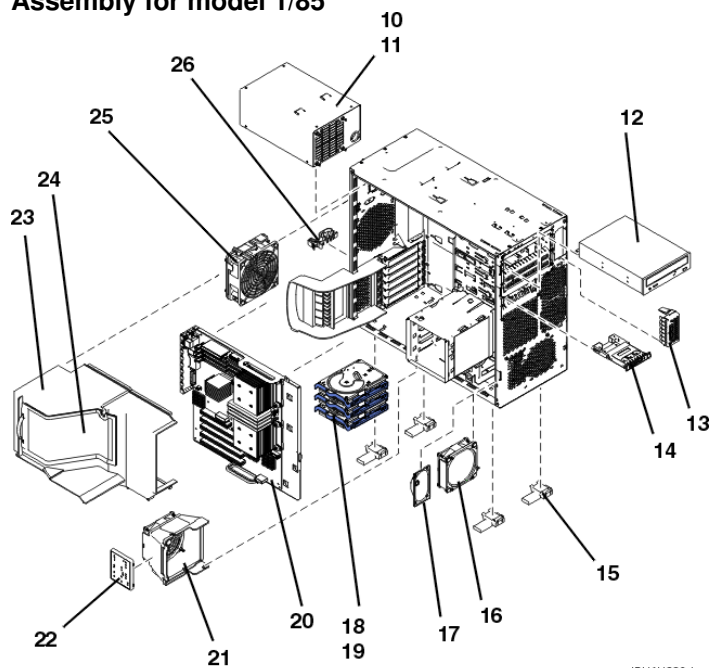
Table 1. Stand-alone cover assembly for model 1/85 part numbers

| Index number | Part number | Units | Description                   |
|--------------|-------------|-------|-------------------------------|
| 1            | 42R4144     | 1     | Rear cover (acoustical cover) |

Service provider information

|   |         |   |                                  |
|---|---------|---|----------------------------------|
| 2 | 39J4143 | 1 | Handle, non acoustical           |
| 2 | 39J4144 |   | Handle, acoustical               |
| 3 | 42R4147 | 1 | Cover, side wrap                 |
| 4 | 03K9553 |   | Screw                            |
| 5 | 42R4146 | 1 | Front cover, acoustical          |
| 6 | 42R4148 |   | Front cover, acoustical          |
| 7 | 42R4143 | 1 | Mount plate for acoustical cover |
| 8 | 33G3907 |   | Screw                            |
| 9 | 13N2428 | 1 | Side access cover                |

Assembly for model 1/85



IPHAU886-1

Table 2. Assembly for model 1/85 part numbers

| Index number | Part number                                      | Units | Description              |
|--------------|--------------------------------------------------|-------|--------------------------|
| 10           | 42R4258<br>42R4274*                              | 1     | 530 watt power supply    |
|              | 39J5221<br>39J4099*                              |       | 750 watt power supply    |
| 11           | 28L0657                                          | 1     | Thumbscrew               |
| 12           | See <a href="#">Removable media device parts</a> |       | Media device             |
| 13           | 39J4135                                          | 1     | USB cable                |
| 14           | 03N7057                                          | 1     | Control (operator) panel |
| 15           | 26K7345                                          | 1 set | Left and right feet      |
| 16           | 39J5381                                          | 1     | Fan, PCI adapter cooling |
| 17           | 39Y9720                                          | 1     | Speaker                  |
| 18           | 26K7320                                          | 1     | DASD carrier             |

Service provider information

|    |                                     |   |                         |
|----|-------------------------------------|---|-------------------------|
| 19 | See <a href="#">Disk drives</a>     |   | DASD                    |
| 20 | See <a href="#">Backplane parts</a> | 1 | System backplane        |
| 21 | 39J3651                             | 1 | DASD fan and plastic    |
| 22 | 42R4235                             | 1 | Light path assembly     |
| 23 | 41R4150                             | 1 | Air baffle base         |
| 24 | 42R4122                             | 1 | Top for air baffle base |
| 25 | 39J5382                             | 1 | Processor fan           |
| 26 | Not available                       | 1 | Cable clamp             |

Parent topic: [Part assembly diagrams](#)

---

## Exchanging the system backplane in the model ESCALA PL 245T/R

**Important:** When you remove the system backplane from the model ESCALA PL 245T/R, the system will lose its settings. In order to restore these settings or any custom settings after the backplane is replaced, if possible, do the following before you remove the system backplane:

1. If you have not done so, verify that the backplane is the failing part.
2. Check and record the server firmware level prior to replacing this part. Refer to [Server firmware fixes](#).
3. Check and record the settings you previously set using the System Management Services (SMS). Refer to [Starting the System Management Services](#) for information about setting up the SMS menus, and [Using the System Management Services](#) for information about using the SMS.

To exchange the system backplane, perform the following procedure:

1. If you are removing the system backplane as part of another procedure, continue to the next step.
2. Perform the following to prepare the system:
  - a. Ensure that the customer has taken appropriate actions to remove the system from normal use.
  - b. Power off the system.
  - c. Disconnect the power source from the system.

**Note:** This system might be equipped with a second power supply. Before continuing with this procedure, ensure that the power source to the system has been completely disconnected.

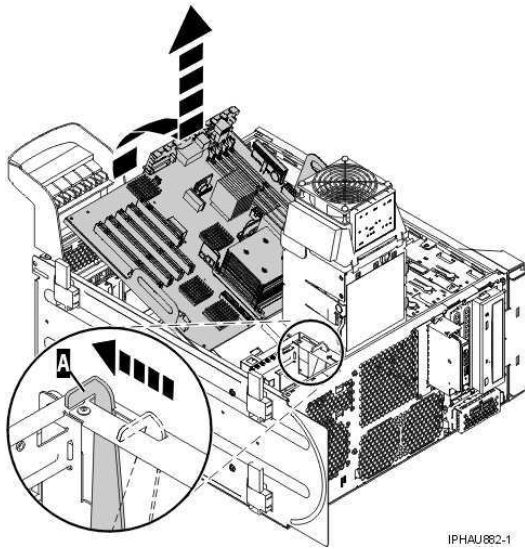
- d. Attach a wrist strap to a metal surface of your hardware to prevent electrostatic discharge from damaging your hardware. If you do not have a wrist strap, touch a metal surface of the system before installing or replacing hardware.

**Note:** Follow the same precautions that you would use if you were not using the wrist strap. A wrist strap is for static control. It will not increase or decrease your risk of receiving electric shock when using or working on electrical equipment.

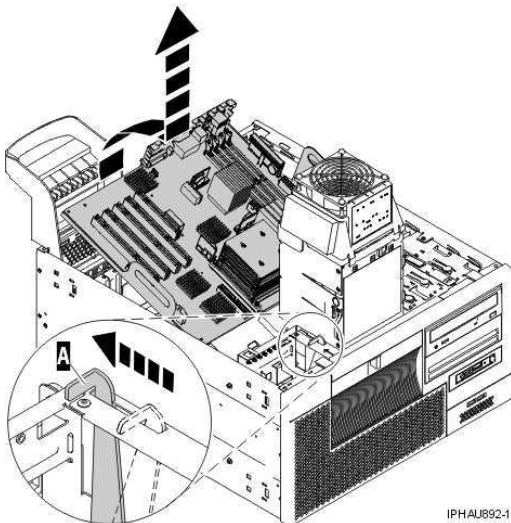
3. Remove all of the cables from the back of the system unit.

4. Remove the service access cover.
5. Remove the unit air baffle. For instructions, see [Model ESCALA PL 245T/R system unit air baffle](#).
6. Lift the adapter retention bracket and remove the adapter cards. For instructions, see [Prepare to remove or install Model ESCALA PL 245T/R dapters with the system power off](#).
7. Remove the processor fan from the processor. For instructions, see [Remove the model ESCALA PL 245T/R system unit fans](#).
8. Remove all remaining cables connecting to the system backplane.
9. Position the unit with the system backplane facing up.
10. Slide the planar locking lever to unlock the system backplane.

### Tower unit



### Rack unit



11. Lift the back of the system backplane, farthest from the planar locking lever, and slide it up and out of the system. Double check to ensure that cables are not in the way.
12. Remove the memory from the system backplane. Keep track of the location of each memory stick, each needs to be placed in the same position on the new system backplane.
13. To insert a system backplane, reverse the steps in this procedure.
14. If you replaced the system backplane as part of another procedure, return to that procedure now. If you replaced it because it was not operational, verify that the new resource is functional. See [Verifying the repair](#).
15. Restore the settings using the System Management Services. For instructions, see [Using the System Management Services](#).

**Note:** The first time the system is powered on with the new backplane installed, system firmware progress codes will be seen. Depending on the system configuration different system progress codes will be seen. Use the [system progress code](#) information to determine the appropriate action to take.

**Parent topic:** [Removing and replacing parts in the model ESCALA PL 245T/R](#)

---

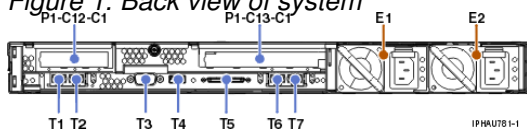
## Locations model ESCALA PL 250R-VL or ESCALA PL 450R-XS

**Note:** The known logical location codes for this unit are listed next to the corresponding physical location in the following information. If you are working with a logical location code for this unit and it is not listed in the following information, contact your next level of support.

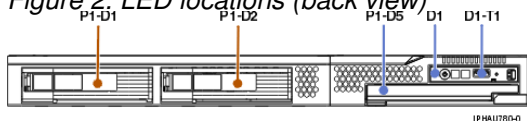
The following diagrams show field replaceable unit (FRU) layout in the system. Use these diagrams with the following tables.

Use the following illustration to help you identify parts of the control panel.

*Figure 1. Back view of system*



*Figure 2. LED locations (back view)*



*Figure 3. System backplane locations*



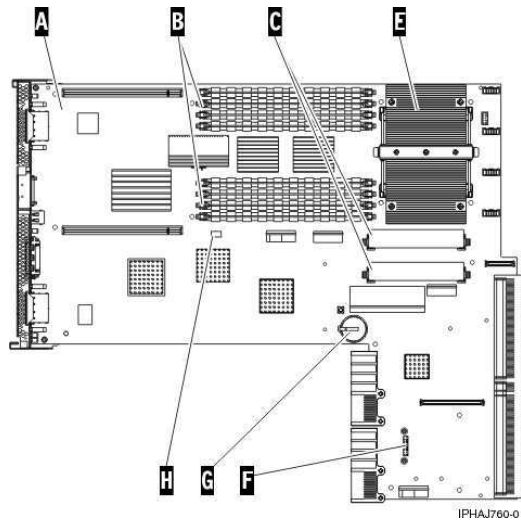
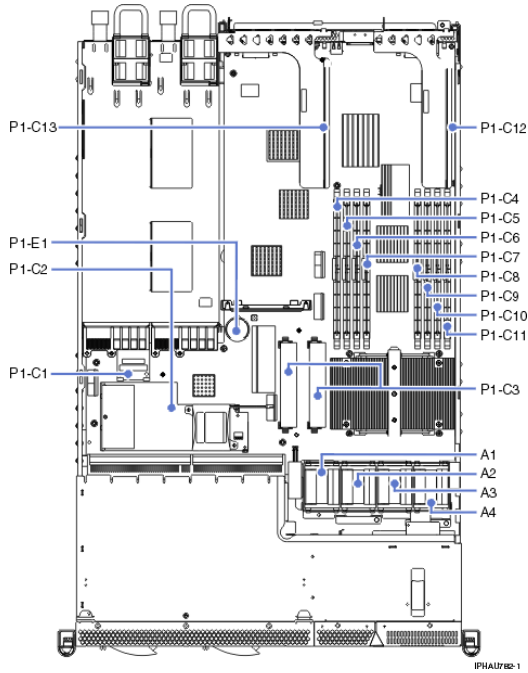


Table 1. System backplane layout

| Index | Description                             |
|-------|-----------------------------------------|
| A     | System backplane                        |
| B     | Memory DIMM                             |
| C     | VRM                                     |
| E     | Processor                               |
| F     | VPD card                                |
| G     | Battery                                 |
| H     | Service processor reset toggle switches |

The following table provides location codes for parts that make up the server.

**Attention:** After replacing any part on a server or expansion unit, perform [Verifying the repair](#).

Table 2. FRU locations and failing components

| Failing item name       | Symbolic failing item name                                                                                                              | Physical location code | Identify LED | Link to part number                    | Failing item removal and replacement procedures |
|-------------------------|-----------------------------------------------------------------------------------------------------------------------------------------|------------------------|--------------|----------------------------------------|-------------------------------------------------|
| System unit             |                                                                                                                                         | Un                     |              |                                        |                                                 |
| Fans                    |                                                                                                                                         |                        |              |                                        |                                                 |
| Fan 1 (left)            |                                                                                                                                         | Un-A1                  | Yes          | <a href="#">Part assembly diagrams</a> | Fan                                             |
| Fan 2                   |                                                                                                                                         | Un-A2                  | Yes          | <a href="#">Part assembly diagrams</a> | Fan                                             |
| Fan 3                   |                                                                                                                                         | Un-A3                  | Yes          | <a href="#">Part assembly diagrams</a> | Fan                                             |
| Fan 4 (right)           |                                                                                                                                         | Un-A4                  | Yes          | <a href="#">Part assembly diagrams</a> | Fan                                             |
| Power supplies          |                                                                                                                                         |                        |              |                                        |                                                 |
| Power supply 1 (left)   |                                                                                                                                         | Un-E1                  | Yes          | <a href="#">Part assembly diagrams</a> | Power supply                                    |
| Power supply 2 (right)  |                                                                                                                                         | Un-E2                  | Yes          | <a href="#">Part assembly diagrams</a> | Power supply                                    |
| Backplanes              |                                                                                                                                         |                        |              |                                        |                                                 |
| System backplane        | ANYPROC<br>CLCKMOD<br>IO_HUB<br>IOBRDG<br>MA_BRDG<br>MEMBRD<br>MEMCTLR<br>NODEPL<br>SI_CARD<br>STORIOA<br>SVCPROC<br>SYSBKPL<br>STORIOA | Un-P1                  | Yes          | <a href="#">Part assembly diagrams</a> | Backplane                                       |
| NVRAM battery           |                                                                                                                                         | Un-P1-E1               |              | <a href="#">Part assembly diagrams</a> | Battery                                         |
| Anchor card             |                                                                                                                                         | Un-P1-C1               | Yes          | <a href="#">Part assembly diagrams</a> |                                                 |
| RAID card               |                                                                                                                                         | Un-P1-C2               | Yes          | <a href="#">Part assembly diagrams</a> |                                                 |
| Processor core VRM      |                                                                                                                                         | Un-P1-C3               | Yes          | <a href="#">Part assembly diagrams</a> |                                                 |
| System backplane ports  |                                                                                                                                         |                        |              |                                        |                                                 |
| Ethernet Port 1 (left)  |                                                                                                                                         | Un-P1-T1               |              |                                        |                                                 |
| Ethernet Port 2 (right) |                                                                                                                                         | Un-P1-T2               |              |                                        |                                                 |
| System port 1 (back)    |                                                                                                                                         | Un-P1-T3               |              |                                        |                                                 |
| USB port 0 (top)        |                                                                                                                                         | Un-P1-T4               |              |                                        |                                                 |
| USB port 1              |                                                                                                                                         | Un-P1-T8               |              |                                        |                                                 |
| SCSI port               |                                                                                                                                         | Un-P1-T5               |              |                                        |                                                 |
| HMC 1 (left)            |                                                                                                                                         | Un-P1-T6               |              |                                        |                                                 |
|                         |                                                                                                                                         | Un-P1-T7               |              |                                        |                                                 |

## Service provider information

|                                                             |                    |                              |     |                                            |                                                                                                                                                 |
|-------------------------------------------------------------|--------------------|------------------------------|-----|--------------------------------------------|-------------------------------------------------------------------------------------------------------------------------------------------------|
| HMC 2<br>(right)                                            |                    |                              |     |                                            |                                                                                                                                                 |
| Adapters                                                    |                    |                              |     |                                            |                                                                                                                                                 |
| PCI adapter<br>in slot 1                                    | PIOCARD            | Un-P1-C12-C1                 | Yes | <a href="#">Part assembly<br/>diagrams</a> | <a href="#">PCI adapter</a>                                                                                                                     |
| PCI adapter<br>in slot 2                                    | PIOCARD            | Un-P1-C13-C1                 | Yes | <a href="#">Part assembly<br/>diagrams</a> | <a href="#">PCI adapter</a>                                                                                                                     |
| PCI riser<br>card                                           |                    | Un-P1-C12                    | Yes |                                            |                                                                                                                                                 |
| PCI riser<br>card                                           |                    | Un-P1-C13                    | Yes |                                            |                                                                                                                                                 |
| PCI bridge<br>set 0                                         | BRDGSET<br>BRDGST1 | Un-P1                        | Yes |                                            | Replace the system<br>backplane and cards<br>using the removal<br>and replacement<br>procedures<br>corresponding to the<br>locations indicated. |
| Memory modules                                              |                    |                              |     |                                            |                                                                                                                                                 |
| Memory<br>DIMM JOA<br>(far left, front<br>view)             | MEMDIMM            | Un-P1-C4                     | Yes | <a href="#">Part assembly<br/>diagrams</a> | <a href="#">Memory module</a>                                                                                                                   |
| Memory<br>DIMM JOB<br>(second from<br>left, front<br>view)  | MEMDIMM            | Un-P1-C5                     | Yes | <a href="#">Part assembly<br/>diagrams</a> | <a href="#">Memory module</a>                                                                                                                   |
| Memory<br>DIMM JOC<br>(third from<br>left, front<br>view)   | MEMDIMM            | Un-P1-C6                     | Yes | <a href="#">Part assembly<br/>diagrams</a> | <a href="#">Memory module</a>                                                                                                                   |
| Memory<br>DIMM JOD<br>(fourth from<br>left, front<br>view)  | MEMDIMM            | Un-P1-C7                     | Yes | <a href="#">Part assembly<br/>diagrams</a> | <a href="#">Memory module</a>                                                                                                                   |
| Memory<br>DIMM J2D<br>(fifth from<br>left, front<br>view)   | MEMDIMM            | Un-P1-C8                     | Yes | <a href="#">Part assembly<br/>diagrams</a> | <a href="#">Memory module</a>                                                                                                                   |
| Memory<br>DIMM J2C<br>(sixth from<br>left, front<br>view)   | MEMDIMM            | Un-P1-C9                     | Yes | <a href="#">Part assembly<br/>diagrams</a> | <a href="#">Memory module</a>                                                                                                                   |
| Memory<br>DIMM J2B<br>(seventh<br>from left,<br>front view) | MEMDIMM            | Un-P1-C10                    | Yes | <a href="#">Part assembly<br/>diagrams</a> | <a href="#">Memory module</a>                                                                                                                   |
| Memory<br>DIMM J2A<br>(far right,<br>front view)            | MEMDIMM            | Un-P1-C11                    | Yes | <a href="#">Part assembly<br/>diagrams</a> | <a href="#">Memory module</a>                                                                                                                   |
| Device locations                                            |                    |                              |     |                                            |                                                                                                                                                 |
| Disk drive 1<br>(3.5 inch)                                  |                    | Un-P1-D1<br>(Un-P1-T9-L8-L0) | Yes | <a href="#">Disk unit parts</a>            |                                                                                                                                                 |

Service provider information

|                             |  |                                                        |     |                              |               |
|-----------------------------|--|--------------------------------------------------------|-----|------------------------------|---------------|
|                             |  | is the logical location code)                          |     |                              |               |
| Disk drive 2 (3.5 inch)     |  | Un-P1-D2 (Un-P1-T9-L5-L0 is the logical location code) | Yes | Disk unit parts              |               |
| Media device                |  | Un-P1-D3                                               |     | Removable media device parts | Media device  |
| Control panel               |  |                                                        |     |                              |               |
| Control panel               |  | Un-D1                                                  |     | Part assembly diagrams       | Control panel |
| Control panel USB connector |  | Un-D1-T1                                               |     | Part assembly diagrams       | Control panel |

Parent topic: [Finding part locations](#)

## Part assembly diagrams for model ESCALA PL 250R-VL or ESCALA PL 450R-XS

This content covers the model ESCALA PL 250R-VL or ESCALA PL 450R-XS.

### Final assembly

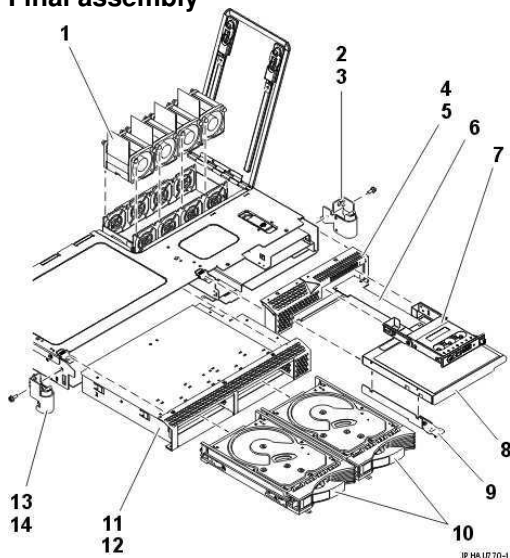


Table 1. Final assembly part numbers

| Index number | Part number | Units per assembly | Description                 |
|--------------|-------------|--------------------|-----------------------------|
| 1            | 39J2228     | 4                  | Fan assembly                |
| 2            | 33P2299     | 1                  | Rack handle assembly, right |
| 3            | 39J1363     | 2                  | Screw                       |

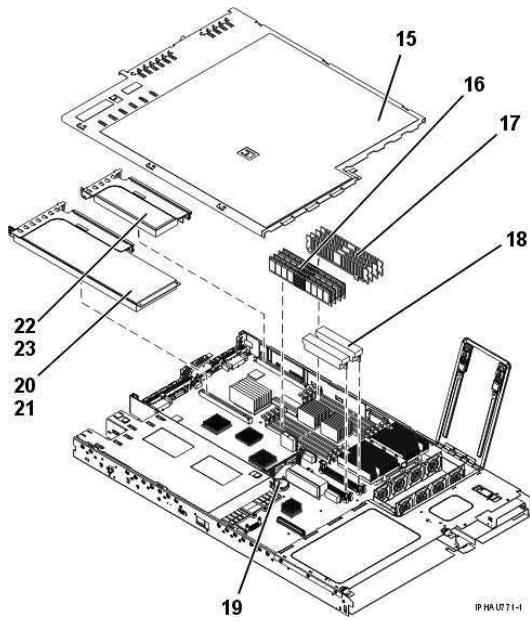


Table 2. Final assembly part numbers

| Index number | Part number                      | Units per assembly | Description                 |
|--------------|----------------------------------|--------------------|-----------------------------|
| 15           | 97P5975                          | 1                  | Access cover assembly, top  |
| 16           | See <a href="#">Memory parts</a> | AR                 | Memory module (DIMM)        |
| 17           | 39J2432                          | AR                 | Memory module (DIMM) filler |
| 18           | 03N6792                          | 2                  | Voltage regulator module    |
| 19           | 16G8095                          | 1                  | Battery, time-of-day        |
| 20           | 03N6846                          | 1                  | PCI adapter riser, long     |
| 21           | 39J1401                          | 1                  | PCI filler                  |
| 22           | 03N6843                          | 1                  | PCI adapter riser, short    |
| 23           | 39J1401                          | 1                  | PCI filler                  |

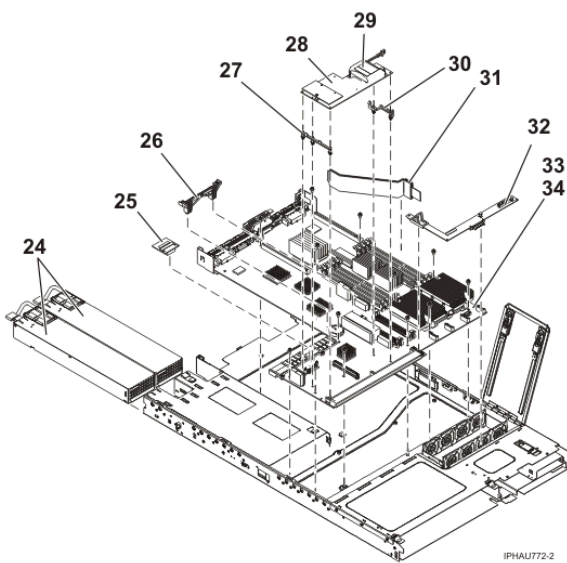


Table 3. Final assembly part numbers

| Index number | Part number                      | Units per assembly | Description                    |
|--------------|----------------------------------|--------------------|--------------------------------|
| 24           | See <a href="#">Power parts</a>  | AR                 | Power supply                   |
|              | 97P6025                          | 1                  | Filler assembly power supply   |
| 25           | See <a href="#">VPD parts</a>    | 1                  | VPD card                       |
| 26           | 39J0931                          | 1                  | Support long PCI adapter       |
| 27           | 39J2595                          | 1                  | Support rail assembly          |
| 28           | 80P6042                          | 1                  | RAID card assembly             |
| 29           | 39J0374                          | 1                  | Battery with plate             |
| 30           | 26K8899                          | 1                  | Support RAID assembly          |
| 31           | 97P5987                          | 1                  | Baffle, airflow (S-shaped)     |
| 32           | 03N5800                          | 1                  | Media card assembly (L-shaped) |
| 33           | See <a href="#">System parts</a> | 1                  | System backplane               |
| 34           | See <a href="#">System parts</a> |                    | System backplane               |

Parent topic: [Part assembly diagrams](#)

---

## Exchanging the system backplane in the model ESCALA PL 250R-VL or ESCALA PL 450R-XS

To exchange the system backplane in the model ESCALA PL 250R-VL or ESCALA PL 450R-XS, perform the following procedure:

**Attention:** Before you remove or disconnect any components, note where they are connected or installed in the system.

**Note:** When you replace the system backplane assembly or time-of-day battery, you will lose the service processor settings.

Check and record the following service processor settings:

- System name setting. Refer to [Changing system name](#).
- System power settings. Refer to [Controlling the system power](#).
- ASMI service aids settings. Refer to [Troubleshooting the system using system service aids](#).
- System configuration settings. Refer to [Changing system configuration](#).
- Network services settings. Refer to [Configuring network services](#).
- Login profile settings. Refer to [Setting up login profile](#).
- Processing unit power control network identifier. Refer to [Changing processing unit power control network identifier](#).
- Server firmware. Refer to [Server firmware fixes](#). The system might need to be updated to the latest server firmware code level after you replace the system backplane.
- Also service processor settings that may have been set using operating system commands.

1. If you are removing the system backplane as part of another procedure, continue to the next step. If you are removing the system backplane because it is not operational, verify that it is the failing part. See [Identify a failing part](#).
2. Perform the following to prepare the system:
  - a. Ensure that the customer has taken appropriate actions to remove the server from normal use.
  - b. Power off the system. For instructions, see [Stopping the system](#).
  - c. Disconnect the power source from the system unit.

**Note:** This system might be equipped with a second power supply. Before continuing with this procedure, ensure that the power source to the system is completely disconnected.

- d. Attach a wrist strap to a metal surface of your hardware to prevent electrostatic discharge from damaging your hardware. If you do not have a wrist strap, touch a metal surface on the system unit before installing or replacing hardware.

**Note:** Follow the same precautions that you would use if you were not using the wrist strap. A wrist strap is for static control. It will not increase or decrease your risk of receiving electric shock when using or working on electrical equipment.

- e. Make a note of cable connections and disconnect all of the cables from the system unit.
- f. Move the system unit into the service position. For instructions, see [Place the rack-mounted system in the service position](#).

**Note:** This unit weighs approximately 17 kg (37 pounds) be sure you can safely support this weight when removing the system unit from the rack.

- g. Remove the system unit from the rack, by pressing the release latches on each extended rail, and pulling the unit outward. Place the system unit on a flat work surface.
  - h. Remove the [service access cover](#).
  - i. Open the fan access door on the top of the system unit by releasing the two latches.
3. Prepare to remove the system backplane by doing the following:

**Note:** For reference when doing the steps in this procedure, refer to [Part assembly diagrams for model ESCALA PL 250R-VL or ESCALA PL 450R-XS](#).

- a. Remove the PCI adapter riser cards from the backplane connectors by pulling the riser card assemblies upwards, out of the system unit, and place the riser card assemblies on a flat, antistatic surface.
- b. Remove the long PCI adapter plastic support bracket. Each leg of the bracket fastens through the backplane in opposite directions.
- c. Remove the removable media drive.
- d. Remove the control panel cable from the L-shaped media card which is located behind the operator panel enclosure and in front of the fan assembly.
- e. Remove the L-shaped media card, held in place with snap fasteners.
- f. Remove the S-shaped bracket that holds one end of the L-shaped media card in place. A single screw retains this bracket near the power supply enclosure.
- g. Remove the disk drives. See [Disk drive](#).
- h. Remove the power supplies. See [Power supply](#).
- i. Remove the voltage regulator modules. See [Voltage regulator module](#).
- j. Remove the memory modules. See [Memory modules](#).
- k. Remove the VPD card. See [Exchanging the VPD card](#).
- l. If so equipped, remove the RAID card assembly by releasing the plastic retaining tabs and pulling the card upward.

- m. Disconnect the fan assembly cables from the system backplane.
- n. Remove the screws that attach the system backplane to the system unit.
  - ◇ 12 screws fasten backplane to chassis.
  - ◇ 4 screws fasten backplane connectors to chassis at rear of enclosure. Use care when removing these screws to avoid damaging the threads.

Save these screws because they are needed to install the new backplane.
- 4. Lift and remove the system backplane.
- 5. Replace the system backplane and reassemble the enclosure by reversing the previous steps in this procedure.

**Note:** Review the following before continuing with the next step.

- ◆ Do not attach power cords, power on, or IPL the system until directed to do so. Failure to do so could result in bus renumbering.
- ◆ Do not start the system at this time. You are instructed when to connect the power and start the system later in this procedure.
- ◆ If the system is managed by an HMC, check the system's connection to the HMC through the service network. Before continuing, the HMC and the service network should be operating normally.

Continue with the next step.

- 6. Restore the service processor and SPCN settings:
  - a. After you replace a system backplane assembly, do the following to restore the service processor and SPCN settings:
    - i. Enable the service network access to the service processor by doing one of the following:
      - If the network connection uses the Dynamic Host Configuration Protocol (DHCP) to establish an IP address, and uses a Hardware Management Console (HMC) as the DHCP server, no additional configuration is necessary to enable network access to the service processor. Do the following:
        1. Ensure that the system's service processor is connected to the existing service network by verifying that an HMC service network cable is connected to an HMC port on the system.
        2. Connect all system power cables by plugging them into power outlets.
        3. Can you access the service network?
          - ◆ No: Go to step [6.a.ii](#).
          - ◆ Yes: Go to [Reset the processing unit power control network identifier using the ASMI](#).
      - If the network connection uses DHCP to establish an IP address, but does not use an HMC as the DHCP server, do the following:
        - Complete any network configuration necessary to allow the DHCP server to recognize and assign an IP address to the service processor.
        - Ensure that the system's service processor is connected to the existing service network by verifying that an HMC service network cable is connected to an HMC port on the system.
        - Connect all system power cables by plugging them into power outlets.
        - Can you access the service network?
          - ◆ No: Go to step [6.a.ii](#)
          - ◆ Yes: Go to [Reset the processing unit power control network identifier using the ASMI](#).
      - If the network connection uses static IP address assignments (not managed by an HMC), do the following:
        - Connect a client with a Web browser directly to the service processor network port using one of the following URLs:
          - ◆ <https://192.168.2.147>
          - ◆ <https://192.168.3.147>
        - Connect all system power cables by plugging them into power outlets.
        - On the client's Web browser, Log in to the Advanced System Management Interface (ASMI) with the user ID: `admin` and the default password: `admin`.



#### Service provider information

- Change the `admin` user ID's password and the general user ID's password. Refer to [Changing ASMI password](#).
  - Configure network access using the static IP address. Refer to [Configuring network access](#).
  - Can you access the service network?
    - ◆ No: Go to step [6.a.ii](#).
    - ◆ Yes: Go to step [6.a.iii](#) to reset the processing unit power control network identifier using the ASMI.
- ii. If you are not able to access the service network, reset the service processor network interfaces (and passwords) by doing the following:
1. Move both service processor reset toggle switches from their current position to the opposite position. See [Locations model ESCALA PL 250R-VL or ESCALA PL 450R-XS](#) to identify the service processor reset toggle switches.
  2. Go to [Enable network access to the service processor](#).
- iii. Reset the processing unit power control network identifier using the ASMI. Do the following to set the configuration ID and MTMS values:
1. Follow the instructions in [Changing processing unit power control network identifier](#) to update the processing unit power control network ID. Change the identifier to `C0`.
  2. Follow the instructions in [Setting the system enclosure type](#) to change the system enclosure type.
- iv. Ask the customer to do the following:
- Change the `admin` user ID's password and the general user ID's password. Refer to [Changing ASMI password](#).
  - Set the system name. Refer to [Changing system name](#).
  - Set the time of day. If this server uses an HMC, set the time of day using the ASMI. Refer to [Changing the time of day](#). If this server does not use an HMC, set the time of day using the appropriate operating system command.
  - Reenter any of the following settings that you previously changed through the ASMI, unless you want to use the defaults:
    - System power settings. Refer to [Controlling the system power](#).
    - ASMI service aids settings. Refer to [Troubleshooting the system using system service aids](#).
    - System configuration settings. Refer to [Changing system configuration](#).
    - Network services settings. Refer to [Configuring network services](#).
    - Login profile settings. Refer to [Setting up login profile](#).
  - Reenter any service processor settings that you may have set using operating system commands. You recorded these settings before removing the service processor.
  - Reactivate any Power On Demand devices using the ASMI. Refer to [Using on-demand utilities](#)
  - If the system is managed by an HMC and runs logical partitions, restore the logical partition profiles. Refer to [Restoring profile data using the HMC](#).
  - If your system is managed by an HMC, reset the HMC access password. From the HMC command line, type:

```
chsyspwd -m managed system -t access --passwd --newpasswd  
newpassword
```

#### Where:

- The value for `managed system` is the new service processor's managed system name.
  - No value for `--passwd` is entered thereby allowing authentication
  - The value for `newpassword` is the new password value.
  - If necessary, update to the latest server firmware level. Refer to [Server firmware fixes](#).
  - Reboot in slow mode.
  - Start the system.
7. If you replaced the system backplane as part of another procedure, return to that procedure now. If you replaced the system backplane because it was not operational, verify that the new resource is functional. See [Verifying the repair](#).

**Parent topic:** [Removing and replacing parts in the model ESCALA PL 250R-VL or ESCALA PL 450R-XS](#)

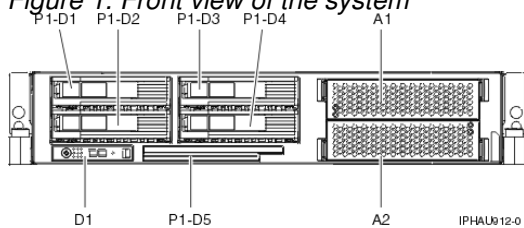
---

## Locations model ESCALA PL 250R-L, PL 250R-L+ or PL 450R-VL+

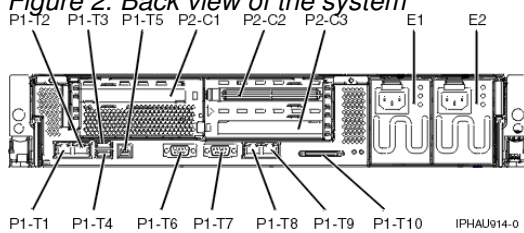
**Note:** The known logical location codes for this unit are listed next to the corresponding physical location in the following information. If you are working with a logical location code for this unit and it is not listed in the following information, contact your next level of support.

The following diagrams show field replaceable unit (FRU) layout in the system. Use these diagrams with the following tables.

*Figure 1. Front view of the system*



*Figure 2. Back view of the system*



*Figure 3. Top view of the system*

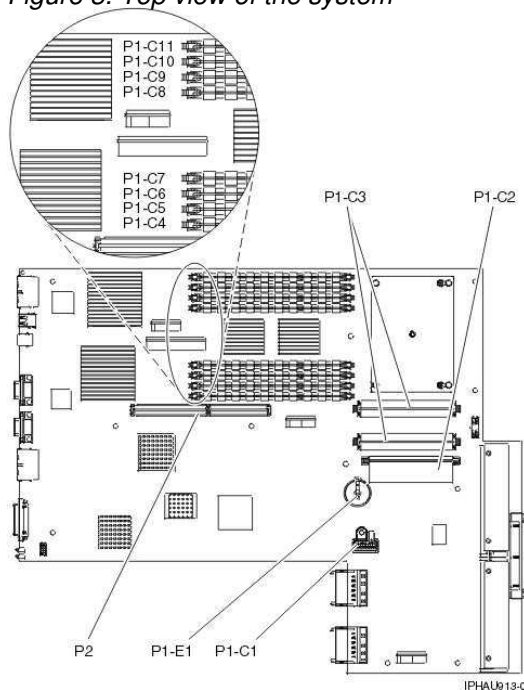
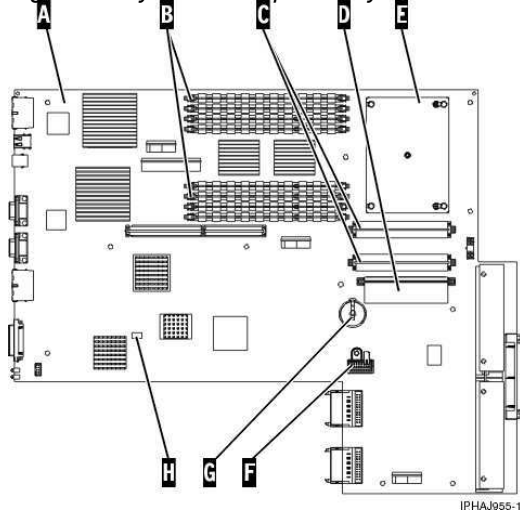


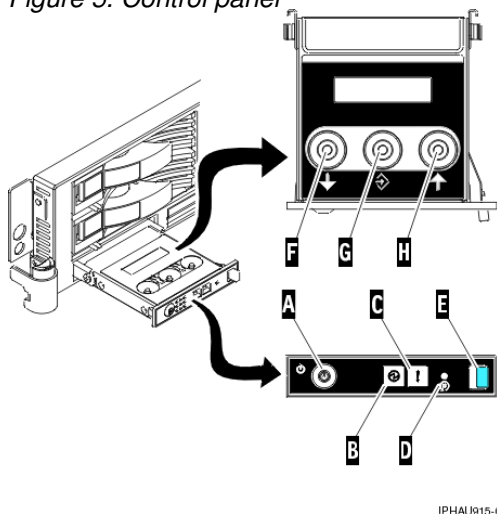
Figure 4. System backplane layout



| Index Number | Description       |
|--------------|-------------------|
| A            | System backplane  |
| B            | Memory DIMM       |
| C            | VRM               |
| D            | Voltage regulator |
| E            | Processor         |
| F            | VPD card          |
| G            | Battery           |
| H            | Reset switch      |

Use the following illustration to help you identify parts of the control panel.

Figure 5. Control panel



| Letter | Name            | Description                                                                                                               |
|--------|-----------------|---------------------------------------------------------------------------------------------------------------------------|
| A      | Power-on button | Turns the system power on and off.                                                                                        |
| B      | Power LED       | Blinking when connected to the power source (system is in standby mode). Solid when the power-on button has been pressed. |
| C      | Attention LED   | Normal state - LED is off.                                                                                                |

|   |                                          |                                                        |
|---|------------------------------------------|--------------------------------------------------------|
| D | Service processor reset switch (pinhole) | Service personnel use.                                 |
| E | Control panel access tab                 | Press tab to gain access to the control panel display. |
| F | Increment down                           | Scrolls the information in the display down.           |
| G | Enter                                    | Enter.                                                 |
| H | Increment up                             | Scrolls the information in the display.                |

The following table provides location codes for parts that make up the server.

**Attention:** After replacing any part on a server or expansion unit, perform [Verifying the repair](#).

Table 1. FRU locations and failing components

| Failing item name      | Symbolic failing item name                                                                                                  | Physical location code | Identify LED | Link to part number          | Failing item removal and replacement procedures |
|------------------------|-----------------------------------------------------------------------------------------------------------------------------|------------------------|--------------|------------------------------|-------------------------------------------------|
| System unit            |                                                                                                                             | Un                     |              |                              |                                                 |
| Fans                   |                                                                                                                             |                        |              |                              |                                                 |
| Fan 1 (top)            |                                                                                                                             | Un-A1                  | Yes          | <a href="#">Power parts</a>  | <a href="#">Fans</a>                            |
| Fan 2 (bottom)         |                                                                                                                             | Un-A2                  | Yes          | <a href="#">Power parts</a>  | <a href="#">Fans</a>                            |
| Power supplies         |                                                                                                                             |                        |              |                              |                                                 |
| Power supply 1 (left)  |                                                                                                                             | Un-E1                  | Yes          | <a href="#">Power parts</a>  | <a href="#">Power supply</a>                    |
| Power supply 2 (right) |                                                                                                                             | Un-E2                  | Yes          | <a href="#">Power parts</a>  | <a href="#">Power supply</a>                    |
| Backplane              |                                                                                                                             |                        |              |                              |                                                 |
| System backplane       | ANYPROC<br>CLKMOD<br>IO_HUB<br>IOBRDG<br>MA_BRDG<br>MEMBRD<br>MEMCTLR<br>NODEPL<br>SI_CARD<br>SVCPROC<br>SYSBKPL<br>STORIOA | Un-P1                  | Yes          | <a href="#">System parts</a> | <a href="#">System backplane</a>                |
| VPD card               | CAPACTY                                                                                                                     | Un-P1-C1               |              | <a href="#">VPD parts</a>    | <a href="#">VPD card</a>                        |
| Voltage regulator 2.5V |                                                                                                                             | Un-P1-C2               | Yes          | <a href="#">Power parts</a>  | <a href="#">Voltage regulator modules</a>       |
| Voltage regulator 1.3V |                                                                                                                             | Un-P1-C3               | Yes          | <a href="#">Power parts</a>  | <a href="#">Voltage regulator modules</a>       |
| Time-of-day battery    | TOD_BAT                                                                                                                     | Un-P1-E1               |              | <a href="#">Power parts</a>  | <a href="#">Time-of-day battery</a>             |

## Service provider information

|                        |                        |                               |     |                 |                                                                                                                               |
|------------------------|------------------------|-------------------------------|-----|-----------------|-------------------------------------------------------------------------------------------------------------------------------|
| PCI adapter enclosure  |                        | Un-P2                         | Yes | 6B15            | PCI adapter                                                                                                                   |
| System backplane ports |                        |                               |     |                 |                                                                                                                               |
| Ethernet Port 1 (left) |                        | Un-P1-T1                      |     |                 |                                                                                                                               |
| Ethernet Port 2        |                        | Un-P1-T2                      |     |                 |                                                                                                                               |
| USB 0 (top)            |                        | Un-P1-T3                      |     |                 |                                                                                                                               |
| USB 1 (bottom)         |                        | Un-P1-T4                      |     |                 |                                                                                                                               |
| Rack indicator         |                        | Un-P1-T5                      |     |                 |                                                                                                                               |
| system port 1 (left)   |                        | Un-P1-T6                      |     |                 |                                                                                                                               |
| system port 2          |                        | Un-P1-T7                      |     |                 |                                                                                                                               |
| HMC 1 (left)           |                        | Un-P1-T8                      |     |                 |                                                                                                                               |
| HMC 2                  |                        | Un-P1-T9                      |     |                 |                                                                                                                               |
| SCSI                   |                        | Un-P1-T10                     |     |                 |                                                                                                                               |
| Adapters               |                        |                               |     |                 |                                                                                                                               |
| PCI adapter in slot 1  | PIOCARD MASBUS SLOTERR | Un-P2-C1                      | Yes | System parts    | PCI adapter                                                                                                                   |
| PCI adapter in slot 2  | PIOCARD MASBUS SLOTERR | Un-P2-C2                      | Yes | System parts    | PCI adapter                                                                                                                   |
| PCI adapter in slot 3  | PIOCARD MASBUS SLOTERR | Un-P2-C3                      | Yes | System parts    | PCI adapter                                                                                                                   |
| PCI bridge set 0       | BRDGSET BRDGST1        |                               |     |                 | Replace the system backplane and cards using the removal and replacement procedures corresponding to the locations indicated. |
| Memory modules         |                        |                               |     |                 |                                                                                                                               |
| Memory module J0A      | MEMDIMM                | Un-P1-C4                      | Yes | Memory parts    | Memory modules                                                                                                                |
| Memory module J0B      | MEMDIMM                | Un-P1-C5                      | Yes | Memory parts    | Memory modules                                                                                                                |
| Memory module J0C      | MEMDIMM                | Un-P1-C6                      | Yes | Memory parts    | Memory modules                                                                                                                |
| Memory module J0D      | MEMDIMM                | Un-P1-C7                      | Yes | Memory parts    | Memory modules                                                                                                                |
| Memory module J2D      | MEMDIMM                | Un-P1-C8                      | Yes | Memory parts    | Memory modules                                                                                                                |
| Memory module J2C      | MEMDIMM                | Un-P1-C9                      | Yes | Memory parts    | Memory modules                                                                                                                |
| Memory module J2B      | MEMDIMM                | Un-P1-C10                     | Yes | Memory parts    | Memory modules                                                                                                                |
| Memory module J2A      | MEMDIMM                | Un-P1-C11                     | Yes | Memory parts    | Memory modules                                                                                                                |
| Device locations       |                        |                               |     |                 |                                                                                                                               |
| Disk drive 1           |                        | Un-P1-D1<br>(Un-P1-T11-L8-L0) | Yes | Disk unit parts | Disk drive                                                                                                                    |

Service provider information

|               |  |                                                         |     |                              |               |
|---------------|--|---------------------------------------------------------|-----|------------------------------|---------------|
|               |  | is the logical location code)                           |     |                              |               |
| Disk drive 2  |  | Un-P1-D2 (Un-P1-T11-L5-L0 is the logical location code) | Yes | Disk unit parts              | Disk drive    |
| Disk drive 3  |  | Un-P1-D3 (Un-P1-T11-L4-L0 is the logical location code) | Yes | Disk unit parts              | Disk drive    |
| Disk drive 4  |  | Un-P1-D4 (Un-P1-T11-L3-L0 is the logical location code) | Yes | Disk unit parts              | Disk drive    |
| IDE drive     |  | Un-P1-D5 (Un-P1-T12-L0 is the logical location code)    |     | Removable media device parts | Media device  |
| Control panel |  |                                                         |     |                              |               |
| Control panel |  | Un-D1                                                   |     | 292F                         | Control panel |

Parent topic: [Finding part locations](#)

## Exchanging the system backplane in the model ESCALA PL 250R-L, ESCALA PL 250R-L+ or ESCALA PL 450R-VL+,

To exchange the system backplane in the model ESCALA PL 250R-L, ESCALA PL 250R-L+ or ESCALA PL 450R-VL+, , perform the following procedure:

Check and record the following service processor settings:

- System name setting. Refer to [Changing system name](#).
- System power settings. Refer to [Controlling the system power](#).
- ASMI service aids settings. Refer to [Troubleshooting the system using system service aids](#).
- System configuration settings. Refer to [Changing system configuration](#).
- Network services settings. Refer to [Configuring network services](#).
- Login profile settings. Refer to [Setting up login profile](#).
- Processing unit power control network identifier. Refer to [Changing processing unit power control network identifier](#).
- Server firmware. Refer to [Server firmware fixes](#). The system may need to be updated to the latest server firmware code level after you replace the service processor.
- Service processor settings that may have been set using operating system commands.

1. If you are removing the system backplane as part of another procedure, continue to the next step. If you are removing the system backplane because it is not operational, verify that it is the failing part. See [Identify a failing part](#).
2. Perform the following procedure to prepare the system:
  - a. Ensure that the customer has taken appropriate actions to remove the server from normal use.
  - b. Power off the system. For instructions, see [Stopping the system](#).
  - c. Disconnect the power source from the system.

**Note:** This system might be equipped with a second power supply. Before continuing with this procedure, ensure that the power source to the system has been completely disconnected.

- d. Attach a wrist strap to a metal surface of your hardware to prevent electrostatic discharge from damaging your hardware. If you do not have a wrist strap, touch a metal surface of the system before installing or replacing hardware.

**Note:** Follow the same precautions that you would use if you were not using the wrist strap. A wrist strap is for static control. It will not increase or decrease your risk of receiving electric shock when using or working on electrical equipment.

3. Remove all of the cables from the back of the system unit.
4. Remove the service access cover.
5. Remove the PCI adapter enclosure by lifting up on the enclosure handle, and then lift the enclosure out of the system unit and place it on a flat, antistatic surface.
6. Remove the fans. See [Fans](#).
7. Remove the control panel and device enclosure. See [Control panel](#).
8. Remove the disk drives. See [Disk drive](#).
9. Remove the power supplies. See [Power supply](#).
10. Remove the voltage regulators. See [Voltage regulator modules](#).
11. Remove the memory modules. See [Memory modules](#).
12. Remove the VPD card. See [VPD card](#).
13. Disconnect the fan assembly cables from the system backplane.
14. Remove the screws that attach the system backplane to the system unit. Be sure to save these screws, they will be needed to install the new backplane. Some of the screws that attach the system backplane to the system unit are screws that also attach:
  - ◆ Connectors to the back of the system unit.
  - ◆ PCI adapter enclosure front supports.
  - ◆ PCI adapter enclosure handle grip post.
  - ◆ VPD card connector.
15. Lift and remove the system backplane.
16. To insert a system backplane, reverse the steps in this procedure. Then continue with the next step.
17. Perform the following procedure to set the configuration ID and MTMS values:
  - a. Complete this step before attempting to power on or IPL the system. If step 17 is not completed before attempting to power on or IPL the system, bus renumbering may occur.
  - b. Use the HMC or PC Web browser to access the ASMI (see [Accessing the Advanced System Management Interface](#)).
  - c. Follow the instructions in [Changing processing unit power control network identifier](#) to update the processing unit power control network ID. Change the identifier to **BA**.
  - d. Follow the instructions in [Setting the system enclosure type](#) to change the system enclosure type.
18. Do not start the system at this time. You will be instructed when to start the system in the procedure to restore service processor settings that follows.
19. After you replace the system backplane assembly, perform the following procedure to restore service processor and SPCN settings:
  - a. Enable network access to the service processor by doing one of the following.
    - ◇ If the network connection uses the Dynamic Host Configuration Protocol (DHCP) to establish an IP address, and uses a Hardware Management Console (HMC) as the DHCP server, no additional configuration is necessary to enable network access to the service processor. Perform the following procedure:
      - i. Ensure that the service processor is connected to the existing service network by verifying that the HMC cable is connected to the HMC port on the service processor assembly.
      - ii. Connect all system power cables by plugging them into power outlets.

**Note:** Do not start the system at this time.

- iii. Can you access the service network?
  - No: Continue with the next step.
  - Yes: Go to step [19.c](#).

- ◇ If the network connection uses DHCP to establish an IP address, but does not use an HMC as the DHCP server, perform the following procedure:
  - i. Complete any network configuration necessary to allow the DHCP server to recognize and assign an IP address to the service processor.
  - ii. Ensure that the service processor is connected to the existing service network by verifying that the network cable is connected to the network port on the service processor assembly.
  - iii. Connect all system power cables by plugging them into power outlets.

**Note:** Do not start the system at this time.

- iv. Can you access the service network?
  - No: Continue with the next step.
  - Yes: Go to step [19.c](#).

- ◇ If the network connection uses static IP address assignments (not managed by an HMC), perform the following procedure:
  - i. Connect a client with a Web browser directly to the service processor network port using one of the following URLs:
    - <https://192.168.2.147>
    - <https://192.168.3.147>
  - ii. Connect all system power cables by plugging them into power outlets.

**Note:** Do not start the system at this time.

- iii. Log on to the Advanced System Management Interface (ASMI) with the user ID `admin` and the default password `admin`.
- iv. Change the admin user ID's password and the general user ID's password. Refer to [Changing the password](#).
- v. Configure network access using the static IP address. Refer to [Configuring network access](#).
- vi. Can you access the service network?
  - No: Continue with the next step.
  - Yes: Go to step [19.c](#).
- b. If you are not able to access the service network, reset the service processor network interfaces (and passwords) by doing the following:
  - i. Move both service processor reset toggle switches from their current position to the opposite position.
  - ii. Go to step [19.a](#).
- c. Reset the processing unit power control network identifier using the ASMI. Perform the following procedure to set the configuration ID and MTMS values:
  - i. Follow the instructions in [Changing processing unit power control network identifier](#) to update the processing unit power control network ID. Change the identifier to `BA`.
  - ii. Follow the instructions in [Setting the system enclosure type](#) to change the system enclosure type.
- d. The customer must do the following:
  - i. Change the admin user ID's password and the general user ID's password. Refer to [Changing the password](#).
  - ii. Set the system name. Refer to [Viewing system name](#).
  - iii. Set the time of day. If this server uses an HMC, set the time of day using the ASMI. Refer to [Viewing time of day](#). If this server does not use an HMC, set the time of day using the appropriate operating system command.
  - iv. Reenter any of the following settings that you previously changed through the ASMI, unless you want to use the defaults:
    - System power settings. Refer to [Controlling the system power](#).
    - ASMI service aids settings. Refer to [Troubleshooting the system using system service aids](#).
    - System configuration settings. Refer to [Changing system configuration](#).
    - Network services settings. Refer to [Configuring network services](#).
    - Login profile settings. Refer to [Setting up login profile](#).
  - v. Reenter any service processor settings that you may have set using operating system commands. You recorded these settings before removing the service



processor.

- vi. Reactivate any Power On Demand devices using the ASMI. Refer to [Using on-demand utilities](#).
- vii. If the system is managed by an HMC and runs logical partitions, restore the logical partition profiles. Refer to [Restoring profile data using the HMC](#).
- viii. Verify the time of day for each partition after the system is powered on and the partitions are activated. If necessary, set the time of day using the appropriate operating system command for each logical partition.
- ix. If your system is managed by an HMC, reset the HMC access password. From the HMC command line, type:

```
chsyspwd -m managed system -t access --passwd --newpasswd newpassword
```

where:

- The value for *managed system* is the new service processor's managed system name.
  - No value for `passwd` is entered thereby allowing authentication.
  - The value for *newpassword* is the new password value.
- x. If necessary, update to the latest server firmware level. Refer to [Server firmware fixes](#).
  - xi. Reboot in slow mode.
  - xii. [Start the system](#).
20. If you replaced the system backplane as part of another procedure, return to that procedure now. If you replaced it because it was not operational, verify that the new resource is functional. See [Verifying the repair](#).

**Parent topic:** [Removing and replacing parts in the model ESCALA PL 250R-L, PL 250R-L+ or PL 450R-VL+](#)

---

## Exchanging the VPD card in the model ESCALA PL 250R-L, ESCALA PL 250R-L+ or ESCALA PL 450R-VL+,

**Attention:** The VPD card contains data which is vital to system operation:

- Machine type, model, and serial number
- System brand
- System unique ID (SUID)
- Activation codes for Power On Demand and Virtualization Engine Technologies (if applicable)

If the VPD card is replaced, this data must be programmed into the replacement VPD card. If the system is still functional prior to the replacement of the VPD card, view and record the System unique ID (SUID).

New, replacement activation codes for Power On Demand and Virtualization Engine Technologies will have to be generated. The original activation codes for the system cannot be reused. Contact your next level of support for new activation codes.

To exchange the VPD card in the model ESCALA PL 250R-L, ESCALA PL 250R-L+ or ESCALA PL 450R-VL+, , perform the following procedure:

1. If you are removing the VPD card as part of another procedure, continue to the next step. If you are removing the VPD card because it is not operational, verify that it is the failing part. See [Identify a failing part](#).
2. If the system is still functional and you are replacing the VPD card with a new VPD card, view and record the System unique ID (SUID). This can be done by using a Hardware Management Console (HMC) or PC to access the ASMI. Refer to [Accessing the Advanced System Management Interface](#) for information about setting up the ASMI, and [Managing your server using the Advanced System Management Interface](#) for information about using the ASMI. For further information, see [Viewing vital](#)

[product data](#).

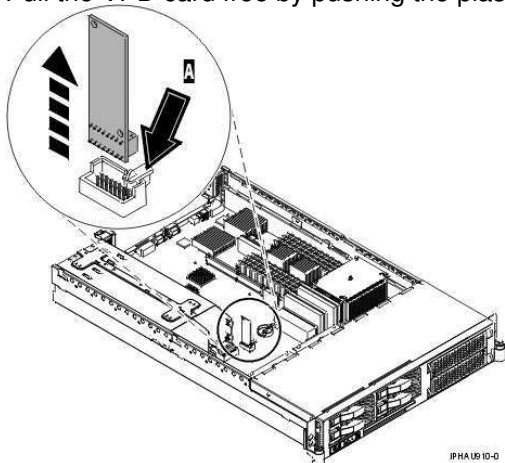
3. Perform the following to prepare the system:
  - a. Ensure that the customer has taken appropriate actions to remove the server from normal use.
  - b. Power off the system. For instructions, see [Stopping the system](#).
  - c. Disconnect the power source from the system.

**Note:** This system might be equipped with a second power supply. Before continuing with this procedure, ensure that the power source to the system has been completely disconnected.

- d. Attach a wrist strap to a metal surface of your hardware to prevent electrostatic discharge from damaging your hardware. If you do not have a wrist strap, touch a metal surface of the system before installing or replacing hardware.

**Note:** Follow the same precautions that you would use if you were not using the wrist strap. A wrist strap is for static control. It will not increase or decrease your risk of receiving electric shock when using or working on electrical equipment.

4. Remove the service access cover. For instructions, see [Remove the service access cover](#).
5. Pull the VPD card free by pushing the plastic tab behind the VPD card A.



6. To insert a VPD card, reverse the steps in this procedure.
7. If you replaced the VPD card as part of another procedure, return to that procedure now.
8. Connect the line cords to each power supply.
9. Use ASMI to set the system identifiers. This can be done by using a Hardware Management Console (HMC) or PC to access the ASMI. Refer to [Accessing the Advanced System Management Interface](#) for information about setting up the ASMI, and [Managing your server using the Advanced System Management Interface](#) for information about using the ASMI. Update the system configuration settings. For further information, see [Programming vital product data](#).
10. If the customer had Power On Demand activation codes, obtain new activation codes from your next level of support and enter the new codes. For more information, see [Working with Power On Demand](#).
11. If the customer had Virtualization Engine Technologies activation codes, obtain new activation codes from your next level of support and enter the new codes. For more information, see [Entering the activation code for Virtualization Engine technologies](#).
12. Power on the system. To review the power on procedure, go to [Powering on and powering off](#).
13. If you replaced the VPD card because it was not operational, verify that the new resource is functional. See [Verifying the repair](#). This ends the procedure.

**Parent topic:** [Removing and replacing parts in the model ESCALA PL 250R-L, PL 250R-L+ or PL 450R-VL+](#)

## Locations model ESCALA PL 250T/R, PL 250T/R+ or PL 450T/R-L+ and 112/85

Use this information to help you map a location code to a position on the server for the 112/85, ESCALA PL 250T/R+ or ESCALA PL 450T/R-L+, 9405-520, 9406-520, and ESCALA PL 250T/R models.

### Mapping physical location codes

**Note:** The known logical location codes for this unit are listed next to the corresponding physical location in the following information. If you are working with a logical location code for this unit and it is not listed in the following information, contact your next level of support.

Use the following illustrations to help you map a location code to a position on the server.

Figure 1. A view of the rack-mounted unit from the front.

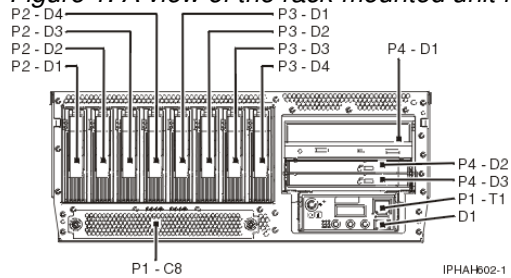


Figure 2. A view of the rack-mounted unit from the back.

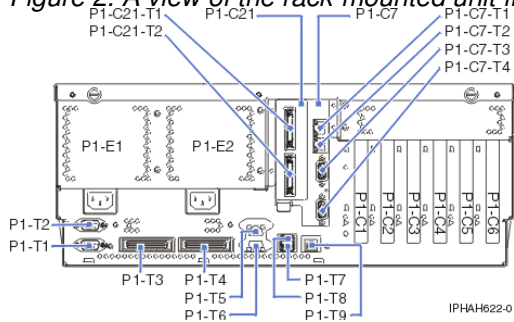


Figure 3. A view of the system backplane from the top.

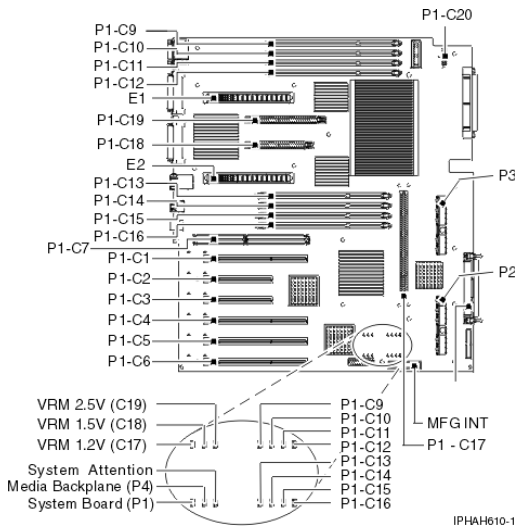


Figure 4. A view of stand-alone system from the front.

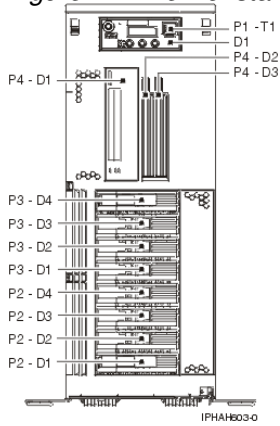
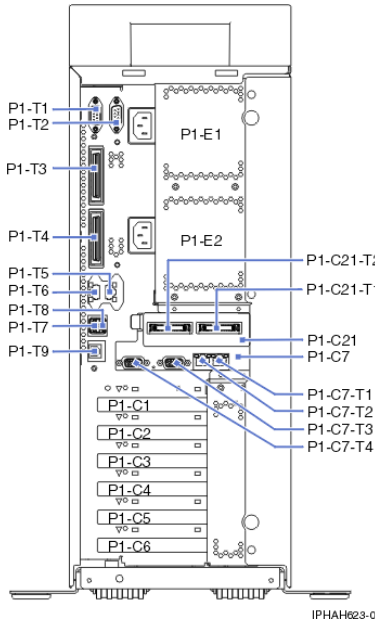
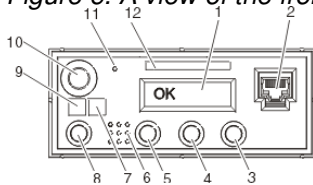


Figure 5. A view of stand-alone system from the back.



Use the following illustration to help you identify parts of the control panel.

Figure 6. A view of the front of the control panel.



| Number | Name                | Description                                                                                                                                                                                                                                                                                                                                                                             |
|--------|---------------------|-----------------------------------------------------------------------------------------------------------------------------------------------------------------------------------------------------------------------------------------------------------------------------------------------------------------------------------------------------------------------------------------|
| 1      | Display             | Displays current status of system startup, or diagnostic information in the event of a hardware problem.                                                                                                                                                                                                                                                                                |
| 2      | Front system port   | Port uses RJ-45 connector. Use to plug in external devices at the front of the system unit.                                                                                                                                                                                                                                                                                             |
| 3      | Increment up        | Scrolls the information in the display up.                                                                                                                                                                                                                                                                                                                                              |
| 4      | Enter               | Enter                                                                                                                                                                                                                                                                                                                                                                                   |
| 5      | Increment down      | Scrolls the information in the display down.                                                                                                                                                                                                                                                                                                                                            |
| 6      |                     |                                                                                                                                                                                                                                                                                                                                                                                         |
| 7      | Attention LED       | Normal state - LED is off                                                                                                                                                                                                                                                                                                                                                               |
| 8      | System reset button | Resets the system                                                                                                                                                                                                                                                                                                                                                                       |
| 9      | Power LED           | Blinking - When connected to the power source (System is in standby mode).<br>Solid - When power-on button has been pressed.<br><br><b>Note:</b> There is approximately a 30-second transition period from the time the power-on button is pressed to when the power LED goes from blinking to on solid. During the transition period, you may observe the blinking intervals speed up. |

Service provider information

|    |                                          |                                    |
|----|------------------------------------------|------------------------------------|
| 10 | Power-on button                          | Turns the system power on and off. |
| 11 | Service processor reset switch (pinhole) | Service personnel use              |
| 12 | Serial number label                      | Displays the system serial number  |

The following table contains location codes for the parts that make up the server.

**Attention:** After replacing any part on a server or expansion unit, perform [Verifying the repair](#).

Table 1. Physical location codes

| Failing item name                                                                                                                                                                                                                                                                                 | Symbolic failing item name                                                                                                                                                                                                       | Physical location code | Identify LED | Link to part number                    | Failing item removal and replacement procedures |
|---------------------------------------------------------------------------------------------------------------------------------------------------------------------------------------------------------------------------------------------------------------------------------------------------|----------------------------------------------------------------------------------------------------------------------------------------------------------------------------------------------------------------------------------|------------------------|--------------|----------------------------------------|-------------------------------------------------|
| System unit                                                                                                                                                                                                                                                                                       |                                                                                                                                                                                                                                  | Un                     |              |                                        | NA                                              |
| <b>Fans</b>                                                                                                                                                                                                                                                                                       |                                                                                                                                                                                                                                  |                        |              |                                        |                                                 |
| Fan 1 (front view, left side)                                                                                                                                                                                                                                                                     |                                                                                                                                                                                                                                  | Un-A1                  | Yes          | <a href="#">Part assembly diagrams</a> | Fan                                             |
| Fan 2                                                                                                                                                                                                                                                                                             |                                                                                                                                                                                                                                  | Un-A2                  | Yes          | <a href="#">Part assembly diagrams</a> | Fan                                             |
| Fan 3 (front view, right side)                                                                                                                                                                                                                                                                    |                                                                                                                                                                                                                                  | Un-A3                  | Yes          | <a href="#">Part assembly diagrams</a> | Fan                                             |
| <b>Power supplies</b>                                                                                                                                                                                                                                                                             |                                                                                                                                                                                                                                  |                        |              |                                        |                                                 |
| Power supply 1                                                                                                                                                                                                                                                                                    | PWRSPLY                                                                                                                                                                                                                          | Un-E1                  | Yes          | <a href="#">Power parts</a>            | <a href="#">Power supply</a>                    |
| Power supply 2                                                                                                                                                                                                                                                                                    | PWRSPLY                                                                                                                                                                                                                          | Un-E2                  | Yes          | <a href="#">Power parts</a>            | <a href="#">Power supply</a>                    |
| <b>Backplanes</b>                                                                                                                                                                                                                                                                                 |                                                                                                                                                                                                                                  |                        |              |                                        |                                                 |
| System backplane                                                                                                                                                                                                                                                                                  | ANYPROC<br>CLCKMOD<br>FRPORT<br>HCA<br>HSL_LNK<br>IO_HUB<br>IOBRDG<br>MA_BRDG<br>MABRCFG<br>MASBUS<br>MEMCTLR<br>NODEPL<br>PIOCARD<br>PPCISYS<br>PRI_PCI<br>SI_PHB<br>SICNTRL<br>SIOADP<br>SPBUS<br>STORIOA<br>SYSBKPL<br>TOPORT | Un-P1                  | Yes          | <a href="#">System parts</a>           | <a href="#">System backplane</a>                |
| <ul style="list-style-type: none"> <li>• Processors</li> <li>• RIO Hub/HSL NIC</li> <li>• RIO/HSL I/O Bridge</li> <li>• RIO/HSL link</li> <li>• Ethernet controller</li> <li>• USB controller (AIX or Linux only)</li> <li>• IDE bridge (AIX or Linux only)</li> <li>• SCSI controller</li> </ul> |                                                                                                                                                                                                                                  |                        |              |                                        |                                                 |

Service provider information

|                                                                                                                 |                                               |             |     |                 |                                               |
|-----------------------------------------------------------------------------------------------------------------|-----------------------------------------------|-------------|-----|-----------------|-----------------------------------------------|
| <ul style="list-style-type: none"> <li>• Logic Oscillator</li> <li>• InfiniBand host channel adapter</li> </ul> |                                               |             |     |                 |                                               |
| Disk drive (1 - 4) backplane                                                                                    |                                               | Un-P2       | Yes | 28D2            | Disk drive backplane                          |
| Disk drive (5 - 8) backplane                                                                                    |                                               | Un-P3       | Yes | 28D2            | Disk drive backplane                          |
| Media drive backplane                                                                                           |                                               | Un-P4       | Yes | 291E            | Removable media drive enclosure and backplane |
| <b>System backplane ports</b>                                                                                   |                                               |             |     |                 |                                               |
| system port 1 (back of system backplane)                                                                        |                                               | Un-P1-T1    |     |                 |                                               |
| S1 system port (front of control panel)                                                                         |                                               | Un-P1-T1    |     |                 |                                               |
| system port 2 (back of system backplane)                                                                        |                                               | Un-P1-T2    |     |                 |                                               |
| RIO/HSL left connector, port 0                                                                                  | HSL_LNK<br>HSL2<br>HSL2_xx<br>HSLH<br>HSLH_xx | Un-P1-T3    |     | External cables | RIO/HSL cables concurrent                     |
| RIO/HSL right connector, port 1                                                                                 | HSL_LNK<br>HSL2<br>HSL2_xx<br>HSLH<br>HSLH_xx | Un-P1-T4    |     | External cables | RIO/HSL cables concurrent                     |
| Integrated dual 1 GB Ethernet controller-port A                                                                 |                                               | Un-P1-T5    |     |                 |                                               |
| Integrated dual 1 GB Ethernet controller-port B                                                                 |                                               | Un-P1-T6    |     |                 |                                               |
| Integrated 2-port universal serial bus (USB) port 0 (AIX or Linux only)                                         |                                               | Un-P1-T7    |     |                 |                                               |
| Integrated 2-port universal serial bus (USB) port 1 (AIX or Linux only)                                         |                                               | Un-P1-T8    |     |                 |                                               |
| Rack indicator connector                                                                                        |                                               | Un-P1-T9    |     |                 |                                               |
| <b>Service processor</b>                                                                                        |                                               |             |     |                 |                                               |
| Service processor card                                                                                          | SVCPROC                                       | Un-P1-C7    |     | 28D7            | Service processor                             |
| Time-of-day (TOD) battery                                                                                       | TOD_BAT                                       | Un-P1-C7-E1 |     | Power parts     | Time-of-day battery                           |
| HMC 1 connector                                                                                                 |                                               | Un-P1-C7-T1 |     |                 |                                               |
| HMC 2 connector                                                                                                 |                                               | Un-P1-C7-T2 |     |                 |                                               |
|                                                                                                                 |                                               | Un-P1-C7-T3 |     |                 |                                               |

Service provider information

|                                        |                              |                                           |     |              |                                                                                                                               |
|----------------------------------------|------------------------------|-------------------------------------------|-----|--------------|-------------------------------------------------------------------------------------------------------------------------------|
| SPCN 0 connector                       |                              |                                           |     |              |                                                                                                                               |
| SPCN 1 connector                       |                              | Un-P1-C7-T4                               |     |              |                                                                                                                               |
| <b>Adapters</b>                        |                              |                                           |     |              |                                                                                                                               |
| PCI adapter in slot 1                  | PIOCARD<br>MASBUS<br>SLOTERR | Un-P1-C1                                  | Yes | System parts | PCI adapter                                                                                                                   |
| PCI adapter in slot 2                  | PIOCARD<br>MASBUS<br>SLOTERR | Un-P1-C2                                  | Yes | System parts | PCI adapter                                                                                                                   |
| PCI adapter in slot 3                  | PIOCARD<br>MASBUS<br>SLOTERR | Un-P1-C3                                  | Yes | System parts | PCI adapter                                                                                                                   |
| PCI adapter in slot 4                  | PIOCARD<br>MASBUS<br>SLOTERR | Un-P1-C4                                  | Yes | System parts | PCI adapter                                                                                                                   |
| PCI adapter in slot 5                  | PIOCARD<br>MASBUS<br>SLOTERR | Un-P1-C5                                  | Yes | System parts | PCI adapter                                                                                                                   |
| PCI adapter in slot 6                  | PIOCARD<br>MASBUS<br>SLOTERR | Un-P1-C6                                  | Yes | System parts | PCI adapter                                                                                                                   |
| Dual channel SCSI RAID enablement card |                              | Un-P1-C8                                  | Yes | 5709         | RAID enablement card                                                                                                          |
| PCI bridge set 1                       | BRDGSET<br>BRDGST1           | Un-P1<br>Un-P1-C1<br>Un-P1-C2             |     |              | Replace the system backplane and cards using the removal and replacement procedures corresponding to the locations indicated. |
| PCI bridge set 2                       | BRDGSET<br>BRDGST2           | Un-P1<br>Un-P1-C3<br>Un-P1-C5<br>Un-P1-C6 |     |              | Replace the system backplane and cards using the removal and replacement procedures corresponding to the locations indicated. |
| PCI bridge set 3                       | BRDGSET<br>BRDGST3           | Un-P1-C4                                  |     |              | Replace the system backplane and cards using the removal and replacement procedures corresponding to the locations indicated. |
| GX adapter                             |                              | Un-P1-C21                                 | Yes | System parts | RIO/HSL or InfiniBand adapter                                                                                                 |
| GX adapter top connector               |                              | Un-P1-C21-T1                              | Yes |              |                                                                                                                               |
| GX adapter bottom connector            |                              | Un-P1-C21-T2                              | Yes |              |                                                                                                                               |
| <b>Memory modules</b>                  |                              |                                           |     |              |                                                                                                                               |
| Memory module 1                        | MEMDIMM                      | Un-P1-C9                                  | Yes | Memory parts | Memory                                                                                                                        |
| Memory module 2                        | MEMDIMM                      | Un-P1-C10                                 | Yes | Memory parts | Memory                                                                                                                        |
|                                        | MEMDIMM                      | Un-P1-C11                                 | Yes | Memory parts | Memory                                                                                                                        |



Service provider information

|                                  |         |           |     |              |                          |
|----------------------------------|---------|-----------|-----|--------------|--------------------------|
| Memory module 3                  |         |           |     |              |                          |
| Memory module 4                  | MEMDIMM | Un-P1-C12 | Yes | Memory parts | Memory                   |
| Memory module 5                  | MEMDIMM | Un-P1-C13 | Yes | Memory parts | Memory                   |
| Memory module 6                  | MEMDIMM | Un-P1-C14 | Yes | Memory parts | Memory                   |
| Memory module 7                  | MEMDIMM | Un-P1-C15 | Yes | Memory parts | Memory                   |
| Memory module 8                  | MEMDIMM | Un-P1-C16 | Yes | Memory parts | Memory                   |
| Vital product data (VPD) card    |         | Un-P1-C20 |     | System parts | VPD card                 |
| Voltage regulator for 1.2 V dc   |         | Un-P1-C17 | Yes | Power parts  | Voltage regulator module |
| Voltage regulator for 1.5 V dc   |         | Un-P1-C18 | Yes | Power parts  | Voltage regulator module |
| Voltage regulator for 2.5 V dc   |         | Un-P1-C19 | Yes | Power parts  | Voltage regulator module |
| <b>Device physical locations</b> |         |           |     |              |                          |
| <b>Control panel</b>             |         |           |     |              |                          |
| Control panel (bottom media bay) |         | Un-D1     |     | 291D         | Control panel            |
| Temperature sensor               |         | Un-D1     |     | 291D         | Control panel            |
| <b>Server firmware</b>           |         |           |     |              |                          |
| Server firmware                  |         | Un-Y1     |     |              |                          |

**Input/output adapter (IOA) assignment rules for**

The following table provides information necessary to identify the input/output processor (IOP) to which IOAs are assigned. The left column indicates the bridge set in which IOA assignment is allowed. Use the right column to determine the IOP to which an IOA is assigned. The first position in the list must be an IOP. The remaining positions might be IOPs or IOAs. IOAs are assigned to the first IOP located to their left in the list. Although IOAs can be manually reassigned using system service tools (SST)/dedicated service tools (DST), the IOA assignments return to the default order after each initial program load (IPL).

Table 2. Model ESCALA PL 250T/R adapter placement

| Multi-adapter bridge domain / Peripheral Component Interconnect (PCI) bridge set | IOA assignment rules          |
|----------------------------------------------------------------------------------|-------------------------------|
| <b>PHB0</b>                                                                      |                               |
| C6, C3, C5                                                                       | C6, C3, embedded SCSI, C5     |
| <b>PHB2</b>                                                                      |                               |
| C1, C2, C4                                                                       | C1, C2, embedded Ethernet, C4 |

Table 3. Model ESCALA PL 250T/R adapter placement, with Feature Codes 8325, 8327 and 8330

| Multi-adapter bridge domain / Peripheral Component Interconnect (PCI) bridge set | IOA assignment rules |
|----------------------------------------------------------------------------------|----------------------|
|----------------------------------------------------------------------------------|----------------------|

|                                           |                          |
|-------------------------------------------|--------------------------|
| <b>PHB0</b>                               |                          |
| C1, C2                                    | C1 embedded Ethernet, C2 |
| <b>PHB2</b> (high speed double data rate) |                          |
| C4                                        | C4 (IOPIess IOAs only)   |
| <b>PHB3</b>                               |                          |
| C3, C5, C6                                | C2, embedded SCSI, C4    |

Parent topic: [Finding part locations](#)

## Part assembly diagrams for model ESCALA PL 250T/R, PL 250T/R+ or PL 450T/R-L+ and 112/85

This content covers the 112/85, ESCALA PL 250T/R+ or ESCALA PL 450T/R-L+, 9405-520, 9406-520, and ESCALA PL 250T/R models.

### Front cover assembly

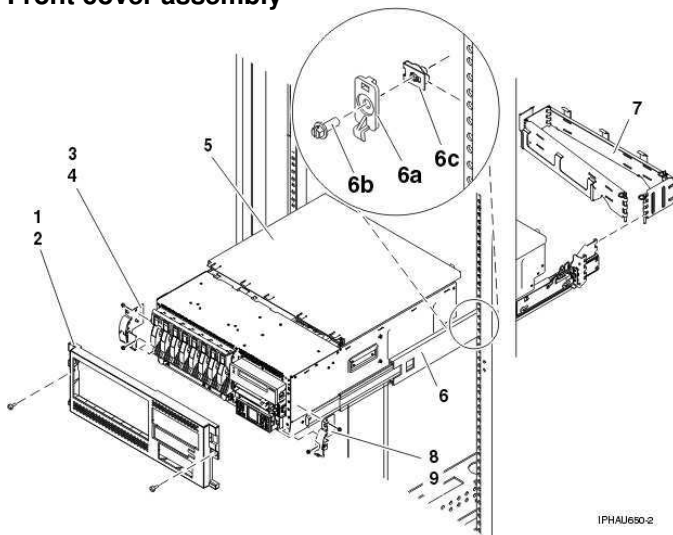


Table 1. Front cover assembly part numbers

| Index number | Part number        | Units | Description                       |
|--------------|--------------------|-------|-----------------------------------|
| 1            | 53P6093            | 1     | Front cover assembly              |
| 1            | 39J2042            | 1     | Bezel assembly                    |
| 2            | 04N6587            | 2     | Thumbscrew, front cover mounting  |
| 3            | 53P4517            | 1     | Rack handle assembly, left        |
| 4            | 09P3744            | 2     | Screw                             |
| 5            | 53P3941            | 1     | Cover, top access                 |
| 6            | 97P5760<br>97P5754 | AR    | Rail kit                          |
| 6a           | NONUM              | AR    | Rack latch (included in rail kit) |
| 6b           | NONUM              | AR    | Screw (included in rail kit)      |
| 6c           | NONUM              | AR    | Nut clip (included in rail kit)   |
| 7            | 39J5304            | 1     | Cable management arm assembly     |

|   |         |   |                             |
|---|---------|---|-----------------------------|
| 8 | 53P4519 | 1 | Rack handle assembly, right |
| 9 | 09P3744 | 2 | Screw                       |

### Final assembly for model

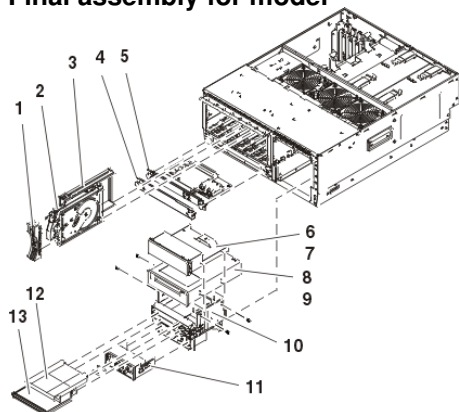


Table 2. Final assembly part numbers

| Index number | Part number                                      | Units | Description                   |
|--------------|--------------------------------------------------|-------|-------------------------------|
| 1            | 97P4178                                          | AR    | Disk unit bezel               |
| 2            | See <a href="#">Disk unit parts</a>              | AR    | Disk unit assembly            |
| 3            | 97P4179                                          | AR    | Disk unit filler assembly     |
| 4            | 39J1004                                          | 1     | RAID enablement filler        |
| 5            | See <a href="#">Storage parts</a>                | 1     | RAID enablement card assembly |
| 6            | 97P6767                                          | 1     | Media device filler           |
| 7            | 33G3907                                          | 4     | Screw                         |
| 8            | See <a href="#">Part number catalog</a>          | 1     | Media device                  |
| 9            | 33G3907                                          | 4     | Screw                         |
| 11           | See <a href="#">Control panel parts</a>          | 1     | Control panel assembly        |
|              | 71P8467                                          | 1     | Power button shield           |
| 12           | 53P5867                                          | 1     | Media device filler           |
| 13           | See <a href="#">Removable media device parts</a> | AR    | Media device                  |

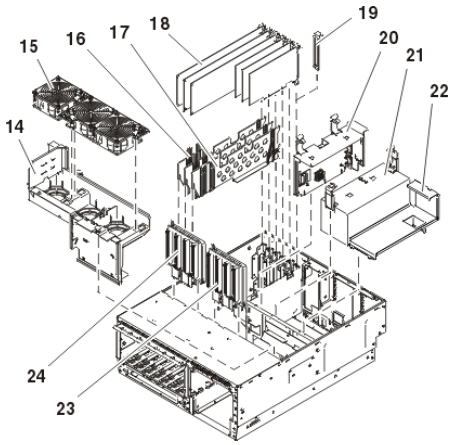


Table 3. Final assembly part numbers

| Index number | Part number                         | Units | Description                                       |
|--------------|-------------------------------------|-------|---------------------------------------------------|
| 14           | 39J5800                             | 1     | Fan tray assembly                                 |
| 15           | 39J2473                             | 3     | Fan assembly                                      |
| 16           | 53P5869                             | 2     | PCI divider assembly, long. Use for slots 5 and 6 |
| 17           | 53P2728                             | 2     | PCI divider. Use for slot 4                       |
| 17           | 53P2729                             | 2     | PCI divider. Use for slot 4                       |
| 18           | See <a href="#">System parts</a>    | AR    | PCI adapter assembly                              |
| 19           | 03K8992                             | AR    | PCI adapter filler                                |
| 20           | See <a href="#">Processor parts</a> | 1     | Service processor assembly                        |
| 21           | See <a href="#">Power parts</a>     | AR    | Power supply assembly                             |
| 22           | 39J0999                             | 1     | Power supply filler                               |
| 23           | See <a href="#">Backplane parts</a> | 1     | Disk unit backplane assembly                      |
| 24           | See <a href="#">Backplane parts</a> | 1     | Disk unit backplane assembly                      |
| 24           | 53P4415                             | 1     | Disk unit backplane filler                        |

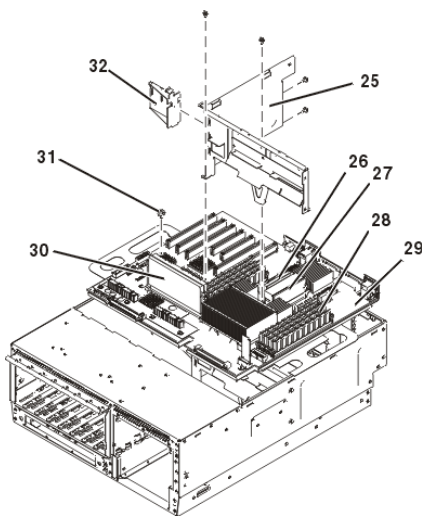


Table 4. Final assembly part numbers

| Index number | Part number                         | Units | Description                       |
|--------------|-------------------------------------|-------|-----------------------------------|
| 25           | 53P4521                             | 1     | Mounting bracket, power supply    |
| 25           | 09P3744                             | 7     | Screw                             |
| 26           | See <a href="#">Power parts</a>     | 1     | 1.5 V or 2.5 V voltage regulator  |
| 27           | See <a href="#">Power parts</a>     | 1     | 2.5 V voltage regulator           |
| 28           | See <a href="#">Memory parts</a>    | AR    | Memory DIMMs                      |
| 29           | See <a href="#">Backplane parts</a> | 1     | System backplane                  |
| 30           | See <a href="#">Power parts</a>     | 1     | 1.2V voltage regulator            |
| 31           | 28L0657                             | 1     | Thumbscrew, planar mounting       |
| 32           | 53P4521                             | 1     | Mounting guide, short PCI divider |
|              | See <a href="#">VPD parts</a>       | 1     | VPD card                          |

#### Stand-alone cover assembly

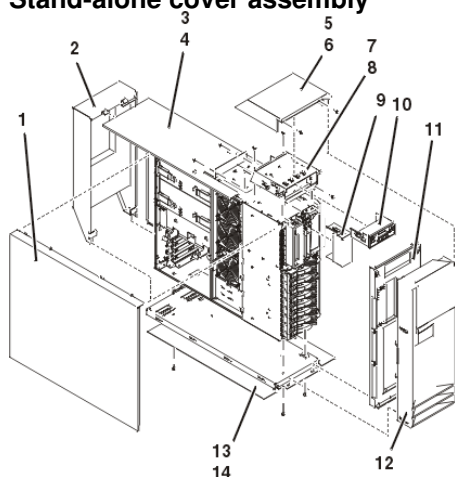


Table 5. Stand-alone cover assembly part numbers

| Index number | Part number                             | Units | Description                    |
|--------------|-----------------------------------------|-------|--------------------------------|
| 1            | 97P3747                                 | 1     | Cover assembly, service access |
| 2            | 97P3772                                 | 1     | Cover assembly, back           |
| 3            | 97P3942                                 | 1     | Cover assembly, top            |
| 4            | 53P4517                                 | 2     | Screw                          |
| 5            | 97P5284                                 | 1     | Cover assembly, top cap        |
| 6            | 09P3744                                 | 2     | Screw                          |
| 7            | 53P4413                                 | 1     | Bracket                        |
| 8            | 09P3744                                 | 4     | Screw                          |
| 9            | 97P2731                                 | 1     | Control panel filler           |
| 10           | See <a href="#">Control panel parts</a> | 1     | Control panel                  |

#### Service provider information

|    |         |   |                       |
|----|---------|---|-----------------------|
|    | 71P8467 | 1 | Power button shield   |
| 11 | 97P5909 | 1 | Cover assembly, front |
| 12 | 97P4148 | 1 | Door assembly         |
| 13 | 53P3949 | 1 | Tip plate             |
| 14 | 09P3744 | 4 | Screw                 |

Parent topic: [Part assembly diagrams](#)

---

## Exchanging the system backplane in the model 112/85, ESCALA PL 250T/R+ or ESCALA PL 450T/R-L+, 9405-520, 9406-520, and ESCALA PL 250T/R

Use this procedure to remove and replace a 112/85, ESCALA PL 250T/R+ or ESCALA PL 450T/R-L+, 9405-520, 9406-520, and ESCALA PL 250T/R system backplane.

To complete these procedures, you might also need to perform removal and replacements from these topics:

- Control panel
- Removable media enclosure
- Fan assembly
- Power supplies
- Voltage regulators
- Disk drives and disk drive backplanes
- PCI adapters and dividers
- Service processor
- SCSI RAID backplane

If you are planning to use this information in printed form, be sure to print all of the information you need. You can find all of the information, in both HTML or PDF format, in the [Installing features and parts](#) topic.

Before performing the following procedures, read the [System Safety Inspection](#).

**Attention:** If you are servicing a rack-mounted system unit, it is strongly recommended that you remove the system drawer from the rack. If you are servicing a stand-alone system unit, place the system on a flat and stable surface on its side. To avoid potential breakage, the system front foot must not be resting on the surface.

Parent topic: [Removing and replacing parts in the model ESCALA PL 250T/R, PL 250T/R+ or PL 450T/R-L+](#)

### Removing the system backplane

**Attention:** Before you remove or disconnect any components, note where they are connected or installed in the system.

1. If you are removing the system backplane as part of another procedure, continue to the next step. If you are removing the system backplane because it is not operational, verify that it is the failing part. See [Identify a failing part](#).
2. Perform the following to prepare the system:
  - a. Ensure that the customer has taken appropriate actions to remove the server from normal use.
  - b. Power off the system. For instructions, see [Stopping the system](#).
  - c. Disconnect the power source from the system.

**Note:** This system might be equipped with a second power supply. Before continuing with this procedure, ensure that the power source to the system has been completely disconnected.

- d. Attach a wrist strap to a metal surface of your hardware to prevent electrostatic discharge from damaging your hardware. If you do not have a wrist strap, touch a metal surface of the system before installing or replacing hardware.

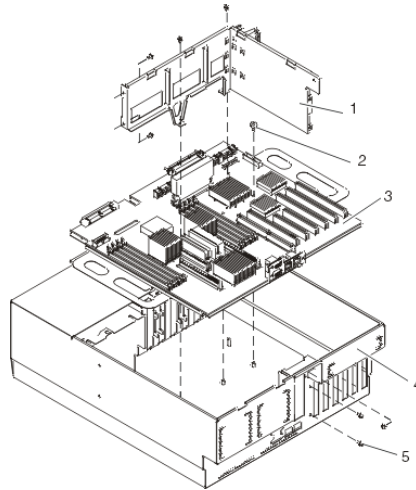
**Note:** Follow the same precautions that you would use if you were not using the wrist strap. A wrist strap is for static control. It will not increase or decrease your risk of receiving electric shock when using or working on electrical equipment.

3. [Remove the front cover](#).
4. Label and disconnect all other cables located at the rear of the system.
5. [Place it in the service position](#).
6. [Remove the service access cover](#).
7. Record the slot number and location of each adapter that is installed in the server.
8. Remove the PCI adapters (see [Removing the PCI adapter with the system power off](#)).
9. Remove the PCI adapter dividers (see [Removing a PCI adapter](#)).
10. Remove both power supplies, if two are present in the system, or remove the power supply and filler (see [Removing the power supply](#)).
11. [Remove the service processor assembly and time-of-day battery](#).
12. [Remove the media-device enclosure](#).

**Note:** If there is a cable from the media bay enclosure to the control panel, unplug the cable as you remove the control panel from the media bay enclosure.

13. Remove the VPD card (see [Exchanging the VPD card](#)).
14. Remove the voltage regulator module (see [Remove the voltage regulator module](#)).
15. Remove the disk drives (see [Remove a disk drive](#)).
16. [Remove the fan tray assembly](#).
17. Remove the disk drive backplanes (see [Replace a disk drive backplane](#)).
18. [Remove memory modules](#).
19. Remove the 7 hex-head screws holding the power supply bay chassis bracket as shown in the following illustration.

## Service provider information



1 Power supply bay chassis bracket

2 Blue thumbscrew

3 System backplane (shown with voltage regulator modules attached)

4 System chassis (shown in service position)

5 Hex-head screw (7)

20. Remove the power supply bay chassis bracket.

21. Remove the blue thumbscrew holding the system backplane to the chassis. Do not remove any other screws from the backplane. The blue thumbscrew is the only screw that needs to be removed in order to release the backplane from the chassis.

**Attention:** Use care when removing the system backplane. Standoffs attached to the chassis base might damage the components attached to the bottom of the system backplane. Do not lift the system backplane by any of the attached modules.

22. To remove the system backplane from the chassis, lift the front edge of the system backplane and pull it towards the front of the system. Lift the system backplane up and out of the system chassis.

23. Place the system backplane in a safe place.

## Replacing the system backplane

To replace the system backplane, do the following:

1. Attach a wrist strap to a metal surface of your hardware to prevent electrostatic discharge from damaging your hardware. If you do not have a wrist strap, touch a metal surface of the system before installing or replacing hardware.

**Note:** Follow the same precautions that you would use if you were not using the wrist strap. A wrist strap is for static control. It will not increase or decrease your risk of receiving electric shock when using or working on electrical equipment.

2. If necessary, remove the system backplane from the antistatic package.
3. Carefully grasp the system backplane along two edges.



4. Lower the system backplane at an angle, so that the rear of the backplane connects with the system chassis first.

**Attention:** Use care when replacing the system backplane. Standoffs attached to the chassis base may damage the components attached to the bottom of the system backplane.

5. Slide the system backplane toward the back of the system chassis, and align the retaining screw hole with the mating screw hole located on the system chassis.
6. Replace the thumbscrew that secures the system backplane to the system chassis.
7. Replace the power supply bay chassis bracket. Insert and tighten the 7 hex-head screws.
8. [Replace the memory modules.](#)
9. Replace the disk drive backplanes (see [Replace a disk drive backplane](#)).
10. [Replace the fan tray assembly.](#)
11. Replace the disk drives (see [Replace a disk drive](#)).
12. Replace the VPD card (see [Exchanging the VPD card](#)).
13. Replace the voltage regulator module (see [Replace the voltage regulator module](#)).
14. [Replace the media-device enclosure.](#)

**Note:** If there is a cable from the media device enclosure to the control panel, reconnect the control panel cable as you install the media device enclosure.

15. [Replace the service processor assembly and time-of-day battery.](#)
16. Replace both power supplies, if two were present in the system, or replace the power supply and filler (see [Replacing the power supply](#)).
17. Replace the PCI adapter dividers (see [Replace a PCI adapter divider](#)).
18. Replace the PCI adapters (see [Replacing the PCI adapter with the system power off](#)).
19. [Replace the service access cover.](#)
20. [Replace the front cover.](#)
21. [Place it in the operating position.](#)
22. Reconnect all signal and power cables to the back of the system.
23. Reconnect the power source to the system.
24. Perform the following to set the configuration ID and MTMS values:
  - a. Use the HMC or PC Web browser to access the ASMI (see [Accessing the Advanced System Management Interface](#)).
  - b. Follow the instructions in [Changing processing unit power control network identifier](#) to update the processing unit power control network ID. Change the identifier to B4.
  - c. Follow the instructions in [Setting the system enclosure type](#) to change the system enclosure type.
25. [Start the system.](#)
26. If you replaced the system backplane as part of another procedure, return to that procedure now. If you replaced it because it was not operational, verify that the new resource is functional. See [Verifying the repair](#).

---

## Exchanging the VPD card in the model 112/85, ESCALA PL 250T/R+ or ESCALA PL 450T/R-L+, 9405-520, 9406-520, and ESCALA PL 250T/R

**Attention:** The VPD card contains data which is vital to system operation:

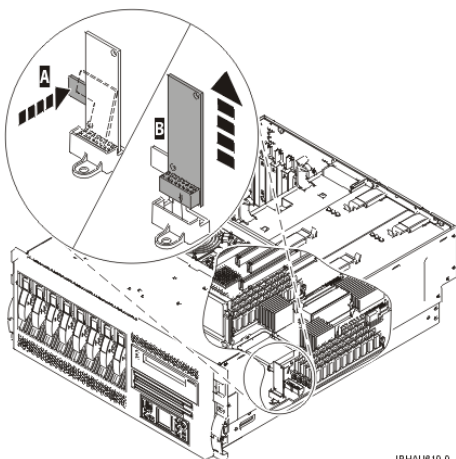
- Machine type, model, and serial number
- System brand
- System unique ID (SUID)
- Activation codes for Power On Demand and Virtualization Engine Technologies (if applicable)

If the VPD card is replaced, this data must be programmed into the replacement VPD card. If the system is still functional prior to the replacement of the VPD card, view and record the System unique ID (SUID).

New, replacement activation codes for Power On Demand and Virtualization Engine Technologies will have to be generated. The original activation codes for the system cannot be reused. Contact your next level of support for new activation codes.

To exchange the VPD card in the model 112/85, ESCALA PL 250T/R+ or ESCALA PL 450T/R-L+, 9405-520, 9406-520, and ESCALA PL 250T/R, perform the following procedure:

1. If you are removing the VPD card as part of another procedure, continue to the next step. If you are removing the VPD card because it is not operational, verify that it is the failing part. See [Identify a failing part](#).
2. If the system is still functional and you are replacing the VPD card with a new VPD card, view and record the System unique ID (SUID). This can be done by using a Hardware Management Console (HMC) or PC to access the ASMI. Refer to [Accessing the Advanced System Management Interface](#) for information about setting up the ASMI, and [Managing your server using the Advanced System Management Interface](#) for information about using the ASMI. For further information, see [Viewing vital product data](#).
3. Power off the system. To review the power-off procedure, go to [Powering on and powering off](#).
4. Disconnect the line cords to each power supply.
5. Remove the model ESCALA PL 250T/R and 112/85 media device enclosure. For further instructions, see [Remove the model ESCALA PL 250T/R media device enclosure](#).
6. Unlock the VPD card by pressing on retaining bracket A.
7. Remove the VPD card from its bracket B.
8. To install a VPD card, reverse this procedure. Ensure retaining pin fully engages VPD card.
9. If you replaced the VPD card as part of another procedure, return to that procedure now.
10. Connect the line cords to each power supply.
11. Use ASMI to set the system identifiers. This can be done by using a Hardware Management Console (HMC) or PC to access the ASMI. Refer to [Accessing the Advanced System Management Interface](#) for information about setting up the ASMI, and [Managing your server using the Advanced System Management Interface](#) for information about using the ASMI. Update the system configuration settings. For further information, see [Programming vital product data](#).
12. If the customer had Power On Demand activation codes, obtain new activation codes from your next level of support and enter the new codes. For more information, see [Working with Power On Demand](#).
13. If the customer had Virtualization Engine Technologies activation codes, obtain new activation codes from your next level of support and enter the new codes. For more information, see [Entering the activation code for Virtualization Engine technologies](#).
14. Power on the system. To review the power on procedure, go to [Powering on and powering off](#).
15. If you replaced the VPD card because it was not operational, verify that the new resource is functional. See [Verifying the repair](#). This ends the procedure.



IPHA1R10.0

## Locations model ESCALA PL 450T/R, PL 450T/R+ or PL 850T/R-L+

Use this information to help you map a location code to a position on the server for the ESCALA PL 450T/R+ or ESCALA PL 850T/R-L+, 9406-550, ESCALA PL 450T/R, models.

**Note:** The known logical location codes for this unit are listed next to the corresponding physical location in the following information. If you are working with a logical location code for this unit and it is not listed in the following information, contact your next level of support.

The following diagrams show field replaceable unit (FRU) layout in the system. Use these diagrams with the following tables.

Figure 1. Front view of the system

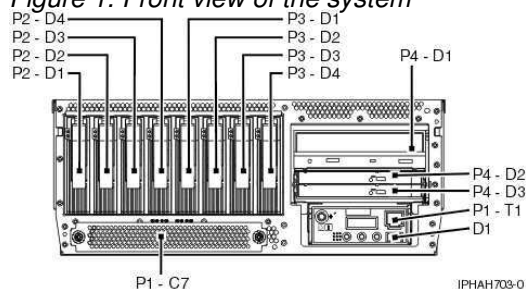


Figure 2. Back view of the system with 2 RIO/HSL ports on the planar and 1 bus card slot. Bus card is installed, port 0 is C6-T1 (closest to board) and port 1 is C6-T2 (towards the top of the card).

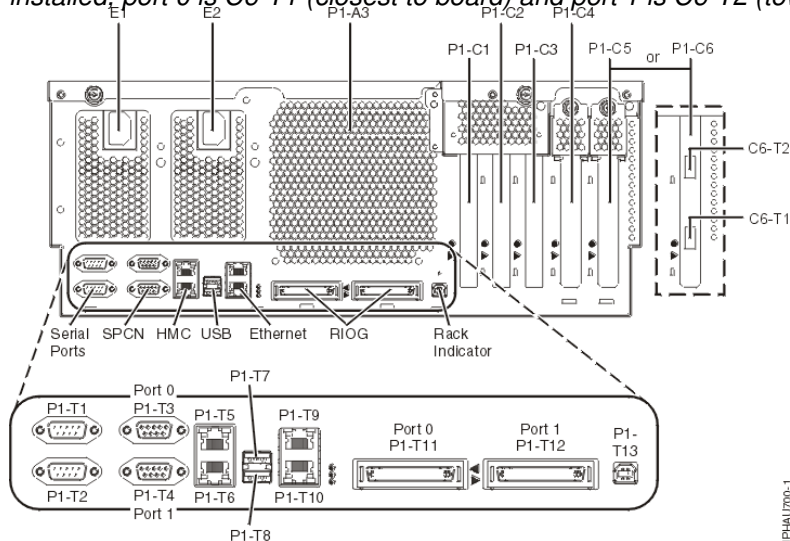


Figure 3. Back view of the stand-alone system with 2 RIO/HSL ports on the planar and 1 bus card slot. Bus card is installed, port 0 is C6-T1 (closest to board) and port 1 is C6-T2 (towards the top of the card).

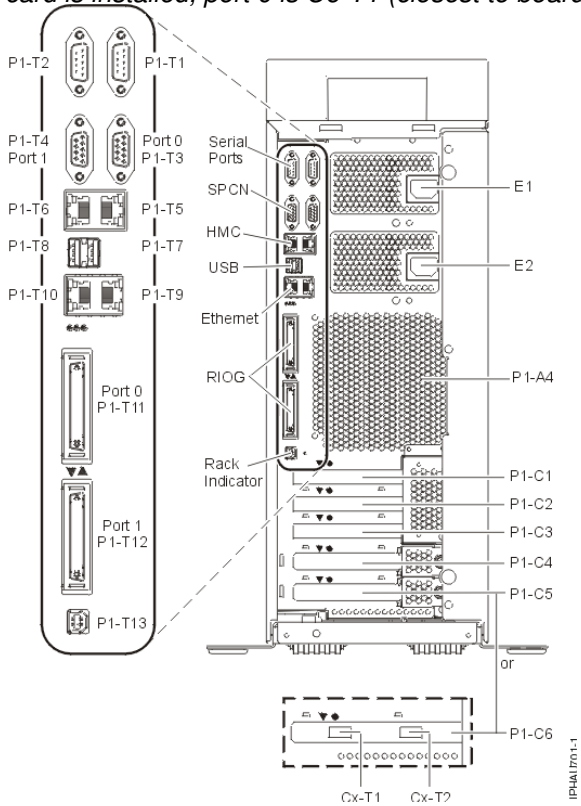


Figure 4. Back view of the system with no RIO/HSL ports on the planar, but has 2 bus card slots (C6 and C14). When bus card is installed port 0 is Cx-T1 (closest to board) and port 1 is Cx-T2 (towards the top of the card).

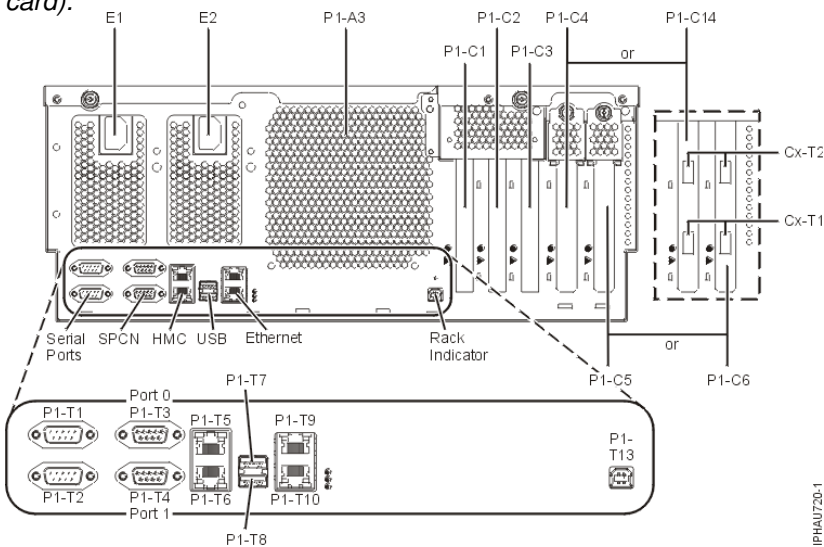


Figure 5. Back view of the stand-alone system with no RIO/HSL ports on the planar, but has 2 bus card slots (C6 and C14). When bus card is installed port 0 is Cx-T1 (closest to board) and port 1 is Cx-T2 (towards the top of the card).

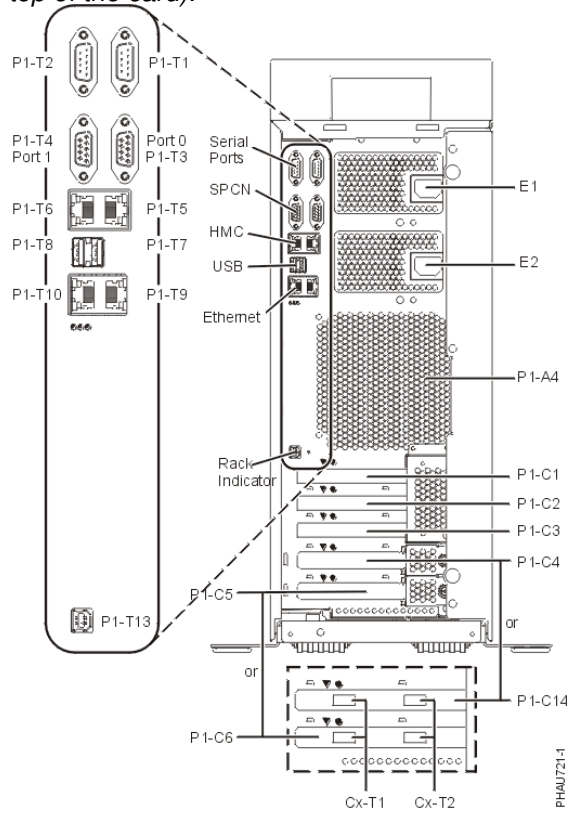


Figure 6. Top view of the system (including service processor reset switch)

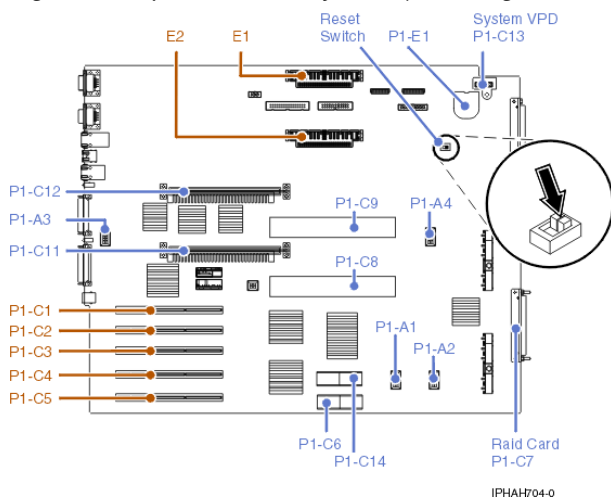
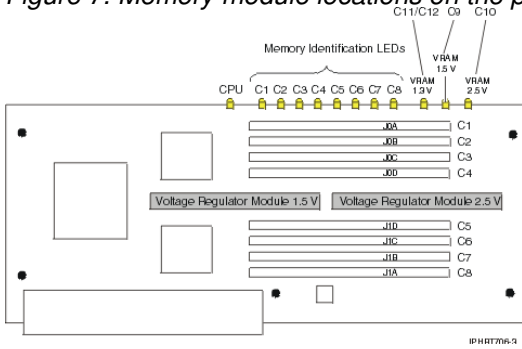


Figure 7. Memory module locations on the processor card



The following table provides location codes for parts that make up the server.

**Attention:** After replacing any part on a server or expansion unit, perform [Verifying the repair](#).

Table 1. FRU locations and failing components

| Failing item name  | Symbolic failing item name                                                                                              | Physical location code | Identify LED | Link to part number                    | Failing item removal and replacement procedures |
|--------------------|-------------------------------------------------------------------------------------------------------------------------|------------------------|--------------|----------------------------------------|-------------------------------------------------|
| System unit        |                                                                                                                         | Un                     |              |                                        |                                                 |
| Fans               |                                                                                                                         |                        |              |                                        |                                                 |
| PCI adapters fan 1 |                                                                                                                         | Un-A1                  | Yes          | <a href="#">Part assembly diagrams</a> | <a href="#">Fans</a>                            |
| PCI adapters fan 2 |                                                                                                                         | Un-A2                  | Yes          | <a href="#">Part assembly diagrams</a> | <a href="#">Fans</a>                            |
| Processor fan 1    |                                                                                                                         | Un-A3                  | Yes          | <a href="#">Part assembly diagrams</a> | <a href="#">Fans</a>                            |
| Processor fan 2    |                                                                                                                         | Un-A4                  | Yes          | <a href="#">Part assembly diagrams</a> | <a href="#">Fans</a>                            |
| Power supplies     |                                                                                                                         |                        |              |                                        |                                                 |
| Power supply 1     | PWRSPLY                                                                                                                 | Un-E1                  | Yes          | <a href="#">51BA</a>                   | <a href="#">Power supply</a>                    |
| Power supply 2     | PWRSPLY                                                                                                                 | Un-E2                  | Yes          | <a href="#">51BA</a>                   | <a href="#">Power supply</a>                    |
| Backplanes         |                                                                                                                         |                        |              |                                        |                                                 |
| System backplane   | HCA<br>HSL_LNK<br>MA_BRDG<br>• SPCN<br>• Card enclosure or backplane<br>• Multi-adapter bridge (all) services processor | Un-P1                  | Yes          | <a href="#">28EC</a>                   | <a href="#">System backplane</a>                |

Service provider information

|                                                                                                                                                                                                                                                                                                                                             |  |                                           |     |                              |                                       |
|---------------------------------------------------------------------------------------------------------------------------------------------------------------------------------------------------------------------------------------------------------------------------------------------------------------------------------------------|--|-------------------------------------------|-----|------------------------------|---------------------------------------|
| <ul style="list-style-type: none"> <li>• RIO Hub/HSWRCARD</li> <li>• RIO I/O Bridge</li> <li>• RIO link</li> <li>• Ethernet controller</li> <li>• USB controller (AIX or Linux only)</li> <li>• IDE bridge (AIX or Linux only)</li> <li>• SCSI controller</li> <li>• Logic oscillator</li> <li>• InfiniBand Host Channel Adapter</li> </ul> |  |                                           |     |                              |                                       |
| SCSI controller 0                                                                                                                                                                                                                                                                                                                           |  | Un-P1-T14                                 |     |                              |                                       |
| SCSI controller 1                                                                                                                                                                                                                                                                                                                           |  | Un-P1-T15                                 |     |                              |                                       |
| IDE controller                                                                                                                                                                                                                                                                                                                              |  | Un-P1-T16                                 |     |                              |                                       |
| Time-of-day battery                                                                                                                                                                                                                                                                                                                         |  | Un-P1-E1                                  |     | Power parts                  | Service processor time-of-day battery |
| Disk drive (1 - 4) backplane                                                                                                                                                                                                                                                                                                                |  | Un-P2 (logical location Un-P1-T15-L15-L0) | Yes | 28F6<br>28F7<br>292C<br>292E | Disk drive backplane                  |
| Disk drive (5 - 8) backplane                                                                                                                                                                                                                                                                                                                |  | Un-P3 (logical location Un-P1-T14-L15-L0) | Yes | 28F6<br>28F7<br>292C<br>292E | Disk drive backplane                  |
| Media drive backplane                                                                                                                                                                                                                                                                                                                       |  | Un-P4                                     | Yes | 28D1<br>291E                 | Media device enclosure                |
| System backplane ports                                                                                                                                                                                                                                                                                                                      |  |                                           |     |                              |                                       |
| system port 1                                                                                                                                                                                                                                                                                                                               |  | Un-P1-T1                                  |     |                              |                                       |
| S1 system port (front of control panel)                                                                                                                                                                                                                                                                                                     |  | Un-P1-T1                                  |     |                              |                                       |
| system port 2                                                                                                                                                                                                                                                                                                                               |  | Un-P1-T2                                  |     |                              |                                       |
| SPCN 0 (upper connector)                                                                                                                                                                                                                                                                                                                    |  | Un-P1-T3                                  |     |                              |                                       |
| SPCN 1                                                                                                                                                                                                                                                                                                                                      |  | Un-P1-T4                                  |     |                              |                                       |

Service provider information

|                                                   |  |                                                                      |     |                      |                           |
|---------------------------------------------------|--|----------------------------------------------------------------------|-----|----------------------|---------------------------|
| (lower connector)                                 |  |                                                                      |     |                      |                           |
| HMC 1 (upper connector)                           |  | Un-P1-T5                                                             |     |                      |                           |
| HMC 2 (lower connector)                           |  | Un-P1-T6                                                             |     |                      |                           |
| USB port 0 (upper connector)                      |  | Un-P1-T7                                                             |     |                      |                           |
| USB port 1 (lower connector)                      |  | Un-P1-T8                                                             |     |                      |                           |
| Ethernet port A (0)                               |  | Un-P1-T9                                                             |     |                      |                           |
| Ethernet port B (1)                               |  | Un-P1-T10                                                            |     |                      |                           |
| RIO Port 0, left                                  |  | Un-P1-T11, not available on ESCALA PL 450T/R+ or ESCALA PL 850T/R-L+ |     |                      |                           |
| RIO Port 1, right                                 |  | Un-P1-T12, not available on ESCALA PL 450T/R+ or ESCALA PL 850T/R-L+ |     |                      |                           |
| Rack indicator                                    |  | Un-P1-T13                                                            |     |                      |                           |
| Processor and processor regulator                 |  |                                                                      |     |                      |                           |
| Processor card 1                                  |  | Un-P1-C9                                                             | Yes | 26F0<br>26F1<br>5237 |                           |
| Processor card 2                                  |  | Un-P1-C8                                                             | Yes | 26F0<br>26F1<br>5237 |                           |
| Voltage regulator 1.5 V on Processor card 2       |  | Un-P1-C8-C9                                                          | Yes | Power parts          | Voltage regulator modules |
| Voltage regulator 2.5 V/1.8 V on Processor card 2 |  | Un-P1-C8-C10                                                         | Yes | Power parts          | Voltage regulator modules |
| Voltage regulator 1.5 V on Processor card 1       |  | Un-P1-C9-C9                                                          | Yes | Power parts          | Voltage regulator modules |
| Voltage regulator 2.5 V/1.8 V on Processor card 1 |  | Un-P1-C9-C10                                                         | Yes | Power parts          | Voltage regulator modules |
|                                                   |  | Un-P1-C11                                                            | Yes | Power parts          |                           |



Service provider information

|                                              |                              |                               |     |              |                                                                                                                               |
|----------------------------------------------|------------------------------|-------------------------------|-----|--------------|-------------------------------------------------------------------------------------------------------------------------------|
| Voltage regulator 1.3 V for Processor card 2 |                              |                               |     |              | Voltage regulator modules                                                                                                     |
| Voltage regulator 1.3 V for Processor card 1 |                              | Un-P1-C12                     | Yes | Power parts  | Voltage regulator modules                                                                                                     |
| VPD card                                     |                              | Un-P1-C13                     |     | System parts | VPD card                                                                                                                      |
| Adapters                                     |                              |                               |     |              |                                                                                                                               |
| PCI adapter in slot 1                        | PIOCARD<br>MASBUS<br>SLOTERR | Un-P1-C1                      | Yes | System parts | PCI adapter                                                                                                                   |
| PCI adapter in slot 2                        | PIOCARD<br>MASBUS<br>SLOTERR | Un-P1-C2                      | Yes | System parts | PCI adapter                                                                                                                   |
| PCI adapter in slot 3                        | PIOCARD<br>MASBUS<br>SLOTERR | Un-P1-C3                      | Yes | System parts | PCI adapter                                                                                                                   |
| PCI adapter in slot 4                        | PIOCARD<br>MASBUS<br>SLOTERR | Un-P1-C4                      | Yes | System parts | PCI adapter                                                                                                                   |
| PCI adapter in slot 5                        | PIOCARD<br>MASBUS<br>SLOTERR | Un-P1-C5                      | Yes | System parts | PCI adapter                                                                                                                   |
| GX adapter card                              | SIIOADP<br>SIADPCD           | Un-P1-C6                      | Yes | 1806<br>1807 | RIO adapter card                                                                                                              |
| GX adapter card connector 0 (bottom)         |                              | Un-P1-C6-T1                   | Yes |              | RIO cables concurrent                                                                                                         |
| GX adapter card connector 1 (top)            |                              | Un-P1-C6-T2                   | Yes |              | RIO cables concurrent                                                                                                         |
| GX adapter card                              | SIIOADP<br>SIADPCD           | Un-P1-C14                     | Yes | 1806<br>1807 | RIO adapter card                                                                                                              |
| GX adapter card connector 0 (bottom)         |                              | Un-P1-C14-T1                  | Yes |              | RIO cables concurrent                                                                                                         |
| GX adapter card connector 1 (top)            |                              | Un-P1-C14-T2                  | Yes |              | RIO cables concurrent                                                                                                         |
| RAID enablement card                         |                              | Un-P1-C7                      | Yes | 5709         | RAID enablement card                                                                                                          |
| PCI bridge set 1                             | BRDGSET<br>BRDGST1           | Un-P1<br>Un-P1-C1<br>Un-P1-C2 |     |              | Replace the system backplane and cards using the removal and replacement procedures corresponding to the locations indicated. |
| PCI bridge set 2                             | BRDGSET<br>BRDGST2           | Un-P1<br>Un-P1-C4<br>Un-P1-C5 |     |              | Replace the system backplane and cards using the removal and                                                                  |

Service provider information

|                                                                                                                                                                                                                                               |                    |                   |     |              |                                                                  |
|-----------------------------------------------------------------------------------------------------------------------------------------------------------------------------------------------------------------------------------------------|--------------------|-------------------|-----|--------------|------------------------------------------------------------------|
|                                                                                                                                                                                                                                               |                    |                   |     |              | replacement procedures corresponding to the locations indicated. |
| PCI bridge set 3                                                                                                                                                                                                                              | BRDGSET<br>BRDGST3 | Un-P1<br>Un-P1-C3 |     |              |                                                                  |
| Memory modules                                                                                                                                                                                                                                |                    |                   |     |              |                                                                  |
| Memory module 1                                                                                                                                                                                                                               | MEMDIMM            | Un-P1-C8-C1       | Yes | Memory parts | Memory modules                                                   |
| Memory module 2                                                                                                                                                                                                                               | MEMDIMM            | Un-P1-C8-C2       | Yes | Memory parts | Memory modules                                                   |
| Memory module 3                                                                                                                                                                                                                               | MEMDIMM            | Un-P1-C8-C3       | Yes | Memory parts | Memory modules                                                   |
| Memory module 4                                                                                                                                                                                                                               | MEMDIMM            | Un-P1-C8-C4       | Yes | Memory parts | Memory modules                                                   |
| Memory module 5                                                                                                                                                                                                                               | MEMDIMM            | Un-P1-C8-C5       | Yes | Memory parts | Memory modules                                                   |
| Memory module 6                                                                                                                                                                                                                               | MEMDIMM            | Un-P1-C8-C6       | Yes | Memory parts | Memory modules                                                   |
| Memory module 7                                                                                                                                                                                                                               | MEMDIMM            | Un-P1-C8-C7       | Yes | Memory parts | Memory modules                                                   |
| Memory module 8                                                                                                                                                                                                                               | MEMDIMM            | Un-P1-C8-C8       | Yes | Memory parts | Memory modules                                                   |
| Memory module 1                                                                                                                                                                                                                               | MEMDIMM            | Un-P1-C9-C1       | Yes | Memory parts | Memory modules                                                   |
| Memory module 2                                                                                                                                                                                                                               | MEMDIMM            | Un-P1-C9-C2       | Yes | Memory parts | Memory modules                                                   |
| Memory module 3                                                                                                                                                                                                                               | MEMDIMM            | Un-P1-C9-C3       | Yes | Memory parts | Memory modules                                                   |
| Memory module 4                                                                                                                                                                                                                               | MEMDIMM            | Un-P1-C9-C4       | Yes | Memory parts | Memory modules                                                   |
| Memory module 5                                                                                                                                                                                                                               | MEMDIMM            | Un-P1-C9-C5       | Yes | Memory parts | Memory modules                                                   |
| Memory module 6                                                                                                                                                                                                                               | MEMDIMM            | Un-P1-C9-C6       | Yes | Memory parts | Memory modules                                                   |
| Memory module 7                                                                                                                                                                                                                               | MEMDIMM            | Un-P1-C9-C7       | Yes | Memory parts | Memory modules                                                   |
| Memory module 8                                                                                                                                                                                                                               | MEMDIMM            | Un-P1-C9-C8       | Yes | Memory parts | Memory modules                                                   |
| <sup>1</sup> A logical location code with the form of Un-P1-Cn-Tn-Ln-Ln indicates that the disk is attached to a disk controller on a PCI adapter. Cn identifies the card slot of the PCI adapter. Tn identifies the port on the PCI adapter. |                    |                   |     |              |                                                                  |
| Control panel                                                                                                                                                                                                                                 |                    |                   |     |              |                                                                  |
| Control panel                                                                                                                                                                                                                                 |                    | Un-D1             |     | 291D         | Control panel and signal cable                                   |
| Temperature sensor                                                                                                                                                                                                                            |                    | Un-D1             |     | 291D         | Control panel and signal cable                                   |

**Input/output adapter (IOA) assignment rules for**

The following table provides information necessary to identify the input/output processor (IOP) to which IOAs are assigned. The left column indicates the bridge set in which IOA assignment is allowed. Use the right column to determine the IOP to which an IOA is assigned. The first position in the list must be an IOP. The

remaining positions might be IOPs or IOAs. IOAs are assigned to the first IOP located to their left in the list. Although IOAs can be manually reassigned using system service tools (SST)/dedicated service tools (DST), the IOA assignments return to the default order after each initial program load (IPL).

Table 2. Model ESCALA PL 450T/R adapter placement

| Multi-adapter bridge domain / Peripheral Component Interconnect (PCI) bridge set | IOA assignment rules                     |
|----------------------------------------------------------------------------------|------------------------------------------|
| <b>PHB0</b>                                                                      |                                          |
| C1, C2                                                                           | C1, Embedded Ethernet, embedded SCSI, C2 |
| <b>PHB2</b>                                                                      |                                          |
| C3, C4, C5                                                                       | C3, C4, C5                               |

Parent topic: [Finding part locations](#)

## Part assembly diagrams for model ESCALA PL 450T/R, PL 450T/R+ or PL 850T/R-L+

This content covers the 9406-550, ESCALA PL 450T/R+ or ESCALA PL 850T/R-L+, models.

### Final assembly for model ESCALA PL 450T/R, ESCALA PL 450T/R+ or ESCALA PL 850T/R-L+,

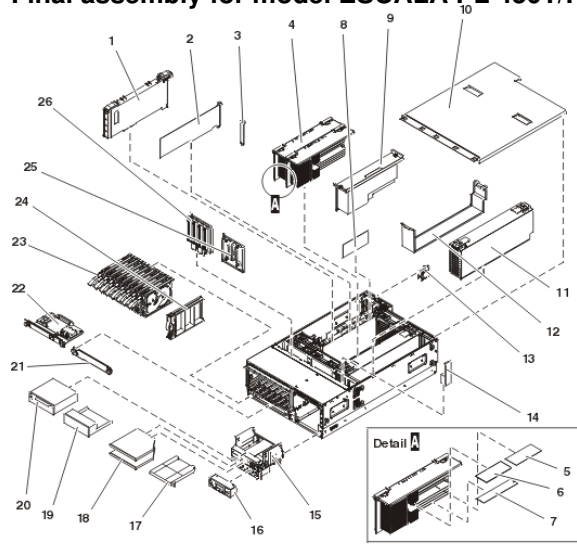
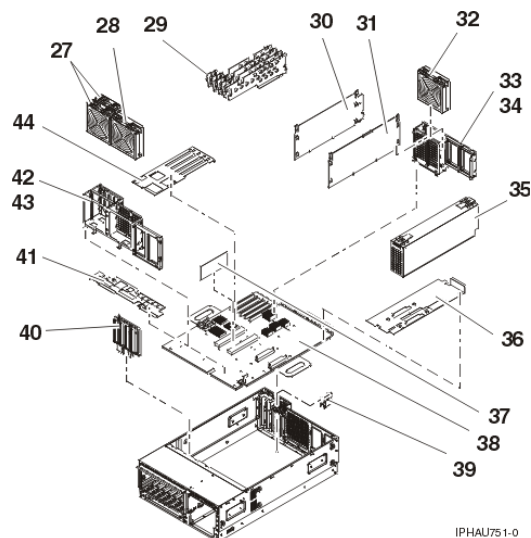


Table 1. Final assembly part numbers for model ESCALA PL 450T/R, ESCALA PL 450T/R+ or ESCALA PL 850T/R-L+,

| Index number | Part number                      | Units | Description |
|--------------|----------------------------------|-------|-------------|
| 1            | See <a href="#">Bus parts</a>    | 1     | RIO adapter |
| 2            | See <a href="#">System parts</a> | AR    | PCI adapter |

## Service provider information

|    |                                                  |    |                                                          |
|----|--------------------------------------------------|----|----------------------------------------------------------|
| 3  | 03K8992                                          | AR | PCI blank                                                |
| 4  | See <a href="#">Processor parts</a>              | AR | System processor                                         |
| 5  | See <a href="#">Power parts</a>                  | 1  | Voltage regulator (1.5 V)                                |
| 6  | See <a href="#">Power parts</a>                  | 1  | Voltage regulator (2.5 V)                                |
| 7  | See <a href="#">Memory parts</a>                 | AR | Memory module                                            |
|    | 44H8167                                          | AR | Filler, memory module                                    |
| 8  | See <a href="#">Power parts</a>                  | 1  | Voltage regulator (1.3 V)                                |
| 9  | 97P4370                                          | AR | System processor filler                                  |
| 10 | 97P4610                                          | 1  | Top cover                                                |
| 11 | See <a href="#">Power parts</a>                  | 1  | Power supply                                             |
| 12 | 39J1219                                          | 1  | Power supply filler                                      |
| 13 | 97P6144                                          | 3  | Retainer for PCI adapter (slots C1, C2, or C3)           |
|    | 97P6794                                          | 2  | Retainer, with bracket, for PCI adapter (slots C4 or C5) |
| 14 | See <a href="#">VPD parts</a>                    | 1  | VPD card                                                 |
| 15 | See <a href="#">Backplane parts</a>              | 1  | Media backplane assembly                                 |
| 16 | See <a href="#">Control panel parts</a>          | 1  | Control panel assembly                                   |
|    | 71P8467                                          | 1  | Power button shield                                      |
| 17 | 53P5867                                          | AR | Media device filler                                      |
| 18 | See <a href="#">Removable media device parts</a> | AR | Media device                                             |
| 19 | 39J1002                                          | AR | Media device filler                                      |
| 20 | See <a href="#">Removable media device parts</a> | AR | Media device                                             |
| 21 | 39J1004                                          | AR | RAID enablement card filler                              |
| 22 | See <a href="#">Storage parts</a>                | AR | RAID enablement card assembly                            |
| 23 | See <a href="#">Disk unit parts</a>              | AR | Disk unit assembly                                       |
|    | 05J7885                                          | AR | Guide rail, disk unit                                    |
| 24 | 97P4179                                          | AR | Disk unit filler assembly                                |
| 25 | 97P5270                                          | AR | Disk unit backplane filler                               |
| 26 | See <a href="#">Backplane parts</a>              | AR | Disk unit backplane assembly                             |



IPHAU751-0

Table 2. Final assembly part numbers for model ESCALA PL 450T/R, ESCALA PL 450T/R+ or ESCALA PL 850T/R-L+, , continued

| Index number | Part number                         | Units | Description                                              |
|--------------|-------------------------------------|-------|----------------------------------------------------------|
| 27           | 39J2390<br>39J2389                  | 2     | Fan, PCI                                                 |
| 28           | 97P4365                             | 1     | Fan, Processor                                           |
| 29           | 97P5894                             | 4     | PCI adapter divider                                      |
| 30           | NONUM                               | 1     | Processor divider                                        |
| 31           | NONUM                               | 1     | Power supply divider                                     |
| 32           | 97P4365                             | 1     | Fan, Processor                                           |
| 33           | NONUM                               | 1     | Rear support                                             |
| 34           | NONUM                               |       | Screw, rear support                                      |
| 35           | See <a href="#">Power parts</a>     | AR    | Power supply                                             |
| 36           | NONUM                               | 1     | Power supply insulator sheet                             |
| 37           | See <a href="#">Power parts</a>     | 1     | Voltage regulator (1.3V)                                 |
| 38           | See <a href="#">Backplane parts</a> | 1     | System backplane                                         |
| 39           | 97P6144                             | 3     | Retainer for PCI adapter (slots C1, C2, or C3)           |
|              | 97P6794                             | 2     | Retainer, with bracket, for PCI adapter (slots C4 or C5) |
| 40           | See <a href="#">Backplane parts</a> | AR    | Disk unit backplane assembly                             |
| 41           | NONUM                               | 1     | System insulator sheet                                   |
| 42           | NONUM                               | 1     | Front support                                            |
| 43           | NONUM                               |       | Screw, front support                                     |
| 44           | NONUM                               | 1     | PCI card insulator sheet                                 |

### Stand-alone cover assembly

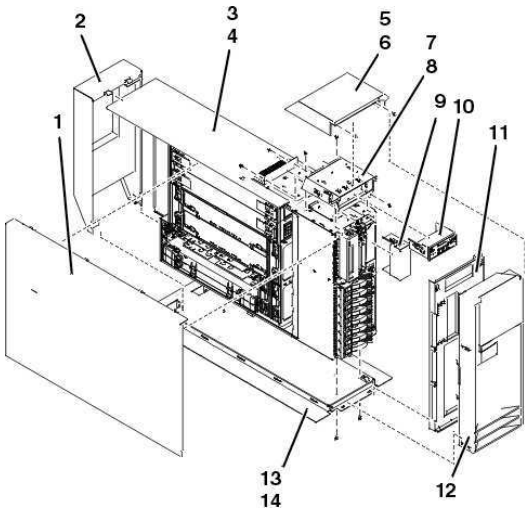
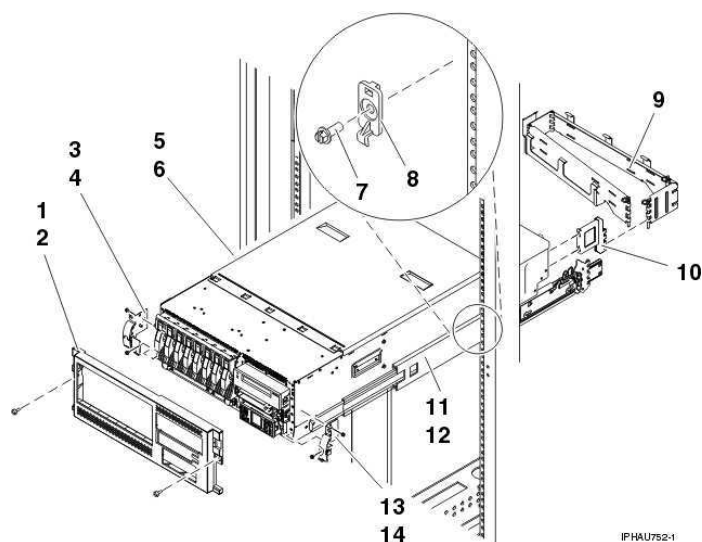


Table 3. Stand-alone cover assembly part numbers

| Index number | Part number                             | Units | Description                             |
|--------------|-----------------------------------------|-------|-----------------------------------------|
| 1            | 97P5244                                 | 1     | Side cover                              |
| 2            | 97P3772                                 | 1     | Back cover                              |
| 3            | 97P5241                                 | 1     | Side wrap                               |
| 4            | NONUM                                   |       | Screw                                   |
| 5            | 97P5284                                 | 1     | Top cap                                 |
| 6            | 09P3744                                 | 2     | Screw                                   |
| 7            | 97P5912                                 | 1     | Control-panel mounting-bracket assembly |
| 8            | NONUM                                   |       | Screw                                   |
| 9            | 97P2731                                 | 1     | Control panel filler                    |
| 10           | See <a href="#">Control panel parts</a> | 1     | Control panel                           |
|              | 71P8467                                 | 1     | Power button shield                     |
| 11           | 97P5907                                 | 1     | Front cover                             |
| 12           | 97P4148                                 | 1     | Door assembly                           |
| 13           | 97P5238                                 |       | Tip plate                               |
| 14           | NONUM                                   |       | Screw                                   |

**Front cover and rail assembly**



IPHAU752-1

Table 4. Front cover and rail assembly part numbers

| Index number | Part number | Units | Description                      |
|--------------|-------------|-------|----------------------------------|
| 1            | 97P5037     | 1     | Front cover assembly model       |
| 1            | 97P6149     | 1     | Front cover assembly server      |
| 2            | 04N6587     | 2     | Thumbscrew, front cover mounting |
| 3            | 97P5896     | 1     | Rack bracket - left              |
| 4            | 09P3744     | 2     | M3.5 screw                       |
| 5, 6, 11, 12 | 97P5271     | 1     | Rail assembly                    |
| 7            | 53P1463     | 2     | Catch rack latch                 |
| 8            | 26H7213     | 2     | M5 screw                         |
| 9            | 39J5304     | 1     | Cable management arm assembly    |
| 10           | 39J1221     | 1     | Cable management bracket         |
| 13           | 97P5895     | 1     | Rack bracket - right             |
| 14           | 09P3744     | 2     | M3.5 screw                       |

Parent topic: [Part assembly diagrams](#)

## Exchanging the system backplane in a model ESCALA PL 450T/R+ or ESCALA PL 850T/R-L+, 9406-550, ESCALA PL 450T/R,

Use this procedure to remove and replace a system backplane in a model ESCALA PL 450T/R+ or ESCALA PL 850T/R-L+, 9406-550, ESCALA PL 450T/R, .

If you are planning to use this information in printed form, be sure to print all of the information you need. You can find all of the information, in both HTML or PDF format, in the [Installing features and parts](#) topic.

Before performing the following procedures, read the [System Safety Inspection](#).

**Attention:** If you are servicing a rack-mounted system unit, it is strongly recommended that the system drawer be removed from the rack. If you are servicing a stand-alone system unit, it is strongly recommended that the system be placed on its side, on a flat and stable surface. To avoid potential breakage, the system front foot must not be resting on the surface.

**Attention:** Before you remove or disconnect any components, note where they are connected or installed in the system.

**Note:** When you replace the system backplane assembly or time-of-day battery, you will lose the service processor settings.

Check and record the following service processor settings:

- System name setting. Refer to [Changing system name](#).
- System power settings. Refer to [Controlling the system power](#).
- ASMI service aids settings. Refer to [Troubleshooting the system using system service aids](#).
- System configuration settings. Refer to [Changing system configuration](#).
- Network services settings. Refer to [Configuring network services](#).
- Login profile settings. Refer to [Setting up login profile](#).
- Processing unit power control network identifier. Refer to [Changing processing unit power control network identifier](#).
- Server firmware. Refer to [Server firmware fixes](#). The system may need to be updated to the latest server firmware code level after you replace the service processor.
- Also service processor settings that may have been set using operating system commands.

1. If you are removing the system backplane as part of another procedure, continue to the next step. If you are removing the system backplane because it is not operational, verify that it is the failing part. See [Identify a failing part](#).
2. Perform the following to prepare the system:
  - a. Ensure that the customer has taken appropriate actions to remove the server from normal use.
  - b. Power off the system. For instructions, see [Stopping the system](#).
  - c. Disconnect the power source from the system.

**Note:** This system might be equipped with a second power supply. Before continuing with this procedure, ensure that the power source to the system has been completely disconnected.

- d. Attach a wrist strap to a metal surface of your hardware to prevent electrostatic discharge from damaging your hardware. If you do not have a wrist strap, touch a metal surface of the system before installing or replacing hardware.

**Note:** Follow the same precautions that you would use if you were not using the wrist strap. A wrist strap is for static control. It will not increase or decrease your risk of receiving electric shock when using or working on electrical equipment.

3. Remove the front cover. For instructions, see [Remove the front cover](#).
4. Label and disconnect all other cables located at the rear of the system.
5. Place the system in the service position. For instructions, see [Place the unit in the service position](#).
6. Remove the service access cover. For instructions, see [Remove the service access cover](#).



7. Remove the media-device enclosure. For instructions, see [Remove the media-device enclosure](#).

**Note:** If there is a cable from the media-device enclosure to the control panel, unplug the cable as you remove the control panel from the media-device enclosure.

8. Remove the RAID enablement card, if present. For instructions, see [Remove the RAID enablement card](#).
9. Record the slot number and location of each disk drive that is installed in the server.
10. Remove the disk drives. For instructions, see [Remove a disk drive](#).
11. Remove the disk drive backplanes (see [Replace a disk drive backplane](#)).
12. Remove the fans. For instructions, see [Remove the fans](#).
13. Record the slot number and location of each adapter that is installed in the server.
14. Remove the PCI adapters. For instructions, see [Remove the PCI adapter with the system power off](#).
15. Remove the PCI adapter dividers. For instructions, see [Remove a PCI adapter](#).
16. Remove both power supplies, if two are present in the system, or remove the power supply and filler. For instructions, see [Remove the power supply](#).
17. Remove both processor assemblies, if two are present in the system, or remove the processor assembly and filler. For instructions, see [Remove the processor assembly](#).
18. Remove the voltage regulator module. For instructions, see [Remove the voltage regulator module](#).
19. Remove the processor and power supply dividers.
20. Remove the screws holding the front support bracket.
21. Remove the front support bracket.
22. Remove the VPD card. For instructions, see [Remove the VPD card](#).
23. Remove the time-of-day battery. For instructions, see [Remove the time-of-day battery](#).
24. Remove the screws holding the rear support bracket.
25. Remove the rear support bracket.
26. Remove the PCI adapter insulator sheet, power supply insulator sheet, and system insulator sheet.
27. To remove the system backplane and mounting plate from the chassis, lift the front edge of the system backplane and mounting plate until it clears the locating pins, then pull it towards the front of the system. Lift the system backplane and mounting plate up and out of the system chassis.
28. Remove the screws holding the system backplane to the mounting plate.
29. To replace the backplane, reverse the steps in the removal procedure.
30. Do not start the system at this time. You will be instructed when to start the system in the procedure to restore service processor settings that follows.
31. After you replace the system backplane assembly, do the following to restore service processor and SPCN settings.
  - a. Enable network access to the service processor by doing one of the following.
    - ◇ If the network connection uses the Dynamic Host Configuration Protocol (DHCP) to establish an IP address, and uses a Hardware Management Console (HMC) as the DHCP server, no additional configuration is necessary to enable network access to the service processor. Do the following:
      - i. Ensure that the service processor is connected to the existing service network by verifying that the HMC cable is connected to the HMC port on the service processor assembly.
      - ii. Connect all system power cables by plugging them into power outlets.

**Note:** Do not start the system at this time.

- iii. Can you access the service network?
  - No: Continue with the next step.
  - Yes: Go to step [31.c](#).
- ◇ If the network connection uses DHCP to establish an IP address, but does not use an HMC as the DHCP server, do the following:
  - i. Complete any network configuration necessary to allow the DHCP server to recognize and assign an IP address to the service processor.
  - ii. Ensure that the service processor is connected to the existing service network by verifying that the network cable is connected to the network port on the service processor assembly.
  - iii. Connect all system power cables by plugging them into power outlets.

**Note:** Do not start the system at this time.

- iv. Can you access the service network?
  - No: Continue with the next step.
  - Yes: Go to step [31.c](#).
- ◇ If the network connection uses static IP address assignments (not HMC managed), do the following:
  - i. Connect a client with a Web browser directly to the service processor network port using one of the following URLs:
    - <https://192.168.2.147>
    - <https://192.168.3.147>
  - ii. Connect all system power cables by plugging them into power outlets.

**Note:** Do not start the system at this time.

- iii. Log on to the Advanced System Management Interface (ASMI) with the user ID `admin` and the default password `admin`.
- iv. Change the admin user ID's password and the general user ID's password. Refer to [Changing the password](#).
- v. Configure network access using the static IP address. Refer to [Configuring network access](#).
- vi. Can you access the service network?
  - No: Continue with the next step.
  - Yes: Go to step [31.c](#).
- b. If you are not able to access the service network, reset the service processor network interfaces (and passwords) by doing the following:
  - i. Move both service processor reset toggle switches from their current position to the opposite position.
  - ii. Go to step [31.a](#).
- c. Reset the processing unit power control network identifier using the ASMI. Do the following to set the configuration ID and MTMS values:
  - i. Follow the instructions in [Changing processing unit power control network identifier](#) to update the processing unit power control network ID. Change the identifier to B5.
  - ii. Follow the instructions in [Setting the system enclosure type](#) to change the system enclosure type.
- d. The customer must do the following:
  - i. Change the admin user ID's password and the general user ID's password. Refer to [Changing the password](#).
  - ii. Set the system name. Refer to [Viewing system name](#).
  - iii. Set the time of day. If this server uses an HMC, set the time of day using the ASMI. Refer to [Viewing time of day](#). If this server does not use an HMC, set the time of day using the appropriate operating system command.
  - iv. Reenter any of the following settings that you previously changed through the ASMI, unless you want to use the defaults:
    - System power settings. Refer to [Controlling the system power](#).
    - ASMI service aids settings. Refer to [Troubleshooting the system using system service aids](#).
    - System configuration settings. Refer to [Changing system configuration](#).
    - Network services settings. Refer to [Configuring network services](#).
    - Login profile settings. Refer to [Setting up login profile](#).
  - v. Reenter any service processor settings that you may have set using operating system commands. You recorded these settings before removing the service processor.
  - vi. Reactivate any Power On Demand devices using the ASMI. Refer to [Using on-demand utilities](#).
  - vii. If the system is managed by an HMC and runs logical partitions, restore the logical partition profiles. Refer to [Restoring profile data using the HMC](#).
  - viii. Verify the time of day for each partition after the system is powered on and the partitions are activated. If necessary, set the time of day using the appropriate operating system command for each logical partition.
  - ix. If your system is managed by an HMC, reset the HMC access password. From the HMC command line, type:

#### Service provider information

```
chsyspwd -m managed system -t access --passwd --newpasswd newpassword
```

where:

- The value for *managed system* is the new service processor's managed system name.
  - No value for `passwd` is entered thereby allowing authentication.
  - The value for *newpassword* is the new password value.
- x. If necessary, update to the latest server firmware level. Refer to [Server firmware fixes](#).
  - xi. Reboot in slow mode.
  - xii. [Start the system](#).
32. If you replaced the system backplane as part of another procedure, return to that procedure now. If you replaced it because it was not operational, verify that the new resource is functional. See [Verifying the repair](#).

**Parent topic:** [Removing and replacing parts in the model ESCALA PL 450T/R, PL 450T/R+ or PL 850T/R-L+](#)

---

## Exchanging the VPD card in the model ESCALA PL 450T/R+ or ESCALA PL 850T/R-L+, 9406-550, ESCALA PL 450T/R,

**Attention:** The VPD card contains data which is vital to system operation:

- Machine type, model, and serial number
- System brand
- System unique ID (SUID)
- Activation codes for Power On Demand and Virtualization Engine Technologies (if applicable)

If the VPD card is replaced, this data must be programmed into the replacement VPD card. If the system is still functional prior to the replacement of the VPD card, view and record the System unique ID (SUID).

New, replacement activation codes for Power On Demand and Virtualization Engine Technologies will have to be generated. The original activation codes for the system cannot be reused. Contact your next level of support for new activation codes.

To exchange the VPD card on the model ESCALA PL 450T/R+ or ESCALA PL 850T/R-L+, 9406-550, ESCALA PL 450T/R, , perform the following procedure:

1. If you are removing the VPD card as part of another procedure, continue to the next step. If you are removing the VPD card because it is not operational, verify that it is the failing part. See [Identify a failing part](#).
2. If the system is still functional and you are replacing the VPD card with a new VPD card, view and record the System unique ID (SUID). This can be done by using a Hardware Management Console (HMC) or PC to access the ASMI. Refer to [Accessing the Advanced System Management Interface](#) for information about setting up the ASMI, and [Managing your server using the Advanced System Management Interface](#) for information about using the ASMI. For further information, see [Viewing vital product data](#).
3. Perform the following to prepare the system:
  - a. Ensure that the customer has taken appropriate actions to remove the server from normal use.
  - b. Power off the system. For instructions, see [Stopping the system](#).
  - c. Disconnect the power source from the system.

**Note:** This system might be equipped with a second power supply. Before continuing with this procedure, ensure that the power source to the system has been completely disconnected.

- d. Attach a wrist strap to a metal surface of your hardware to prevent electrostatic discharge from damaging your hardware. If you do not have a wrist strap, touch a metal surface of the system before installing or replacing hardware.

**Note:** Follow the same precautions that you would use if you were not using the wrist strap. A wrist strap is for static control. It will not increase or decrease your risk of receiving electric shock when using or working on electrical equipment.

4. Remove the front cover. For instructions, see [Remove the model ESCALA PL 450T/R front cover](#).
5. Remove the media-device enclosure. For instructions, see [Remove the ESCALA PL 450T/R media-device enclosure](#).

**Note:** If there is a cable from the media-device enclosure to the control panel, unplug the cable as you remove the control panel from the media-device enclosure.

6. Pull the VPD card free by pushing the plastic tab behind the VPD card towards the back of the machine.
7. To insert a VPD card, reverse the steps in this procedure.
8. If you replaced the VPD card as part of another procedure, return to that procedure now.
9. Connect the line cords to each power supply.
10. Use ASMI to set the system identifiers. This can be done by using a Hardware Management Console (HMC) or PC to access the ASMI. Refer to [Accessing the Advanced System Management Interface](#) for information about setting up the ASMI, and [Managing your server using the Advanced System Management Interface](#) for information about using the ASMI. Update the system configuration settings. For further information, see [Programming vital product data](#).
11. If the customer had Power On Demand activation codes, obtain new activation codes from your next level of support and enter the new codes. For more information, see [Working with Power On Demand](#).
12. If the customer had Virtualization Engine Technologies activation codes, obtain new activation codes from your next level of support and enter the new codes. For more information, see [Entering the activation code for Virtualization Engine technologies](#).
13. Power on the system. To review the power on procedure, go to [Powering on and powering off](#).
14. If you replaced the VPD card because it was not operational, verify that the new resource is functional. See [Verifying the repair](#). This ends the procedure.

**Parent topic:** [Removing and replacing parts in the model ESCALA PL 450T/R, PL 450T/R+ or PL 850T/R-L+](#)

---

## Locations model ESCALA PL 1650R-L+ and ESCALA PL 850R/PL 1650R/R+

### Mapping physical location codes

**Note:** The known logical location codes for this unit are listed next to the corresponding physical location in the following information. If you are working with a logical location code for this unit and it is not listed in the following information, contact your next level of support.

Use the following illustrations to help you map a location code to a position on the server.

Figure 1. Front view of the system unit

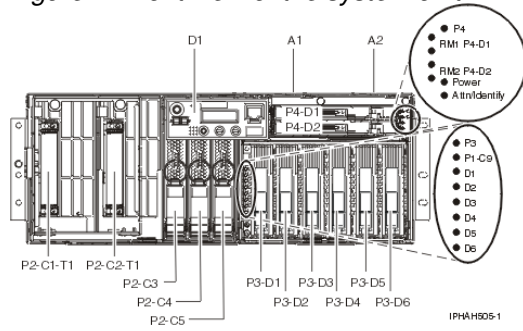


Figure 2. Back view of the system unit

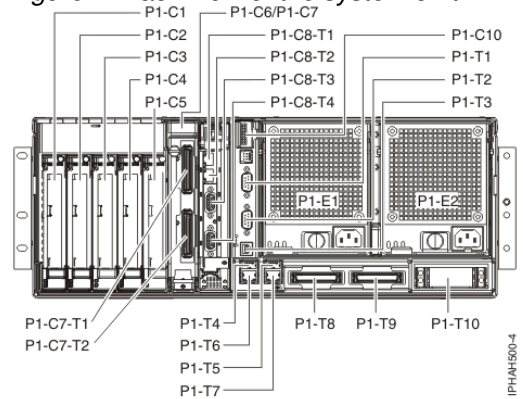
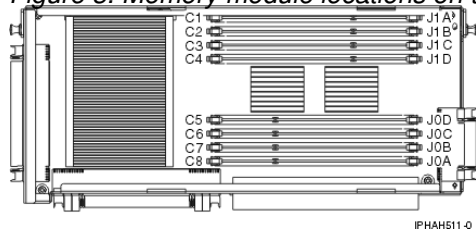
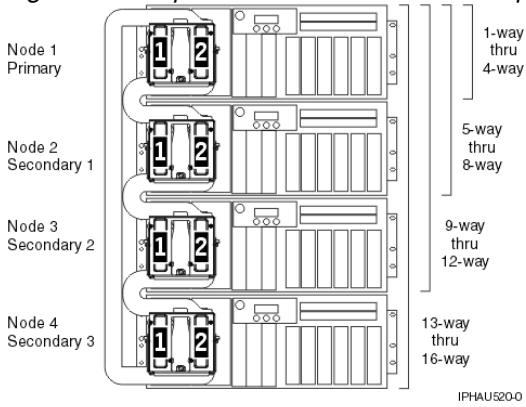


Figure 3. Memory module locations on the processor card (Un-P2-Cx)



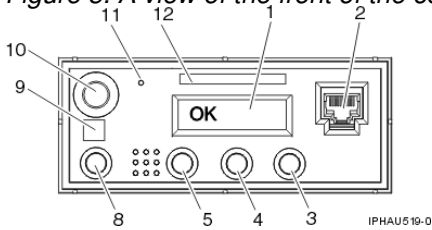
Use the following illustration to map a node location when you are working with a multiple node installation. All of the nodes have the same location codes inside the system unit; only the serial number is different (Utttt.mmm.ssssss-).

Figure 4. Multiple node locations with SMP processor cable shown



Use the following illustration to help you identify parts of the control panel.

Figure 5. A view of the front of the control panel.



| Number | Name                | Description                                                                                                                                                                                                                                                                                                                                                                       |
|--------|---------------------|-----------------------------------------------------------------------------------------------------------------------------------------------------------------------------------------------------------------------------------------------------------------------------------------------------------------------------------------------------------------------------------|
| 1      | Display             | Displays current status of system startup, or diagnostic information in the event of a hardware problem.                                                                                                                                                                                                                                                                          |
| 2      | Front o/p           | Port uses RJ-45 connector. Use to plug in external devices at the front of the system unit.                                                                                                                                                                                                                                                                                       |
| 3      | Increment up        | Scrolls the information in the display up.                                                                                                                                                                                                                                                                                                                                        |
| 4      | Enter               | Enter                                                                                                                                                                                                                                                                                                                                                                             |
| 5      | Increment down      | Scrolls the information in the display down.                                                                                                                                                                                                                                                                                                                                      |
| 8      | System reset button | Resets the system                                                                                                                                                                                                                                                                                                                                                                 |
| 9      | Power LED           | Blinking - When connected to the power source (System is in standby mode). Solid - When power button has been pressed.<br><br><b>Note:</b> There is approximately a 30-second transition period from the time the power-on button is pressed to when the power LED goes from blinking to on solid. During the transition period, you may observe the blinking intervals speed up. |

|    |                                          |                                    |
|----|------------------------------------------|------------------------------------|
| 10 | Power-on button                          | Turns the system power on and off. |
| 11 | Service processor reset switch (pinhole) | Service Personnel Use              |
| 12 | Serial number label                      | Displays the system serial number  |

The following table contains location codes for the parts that make up the server.

**Attention:** After replacing any part on a server or expansion unit, perform [Verifying the repair](#).

Table 1. Physical location codes

| Failing item name                                                                                                                                                                                                                                                                                                   | Symbolic failing item name                                                                                                                                                                 | Physical location code | Identify LED | Link to part number                    | Failing item removal and replacement procedures |
|---------------------------------------------------------------------------------------------------------------------------------------------------------------------------------------------------------------------------------------------------------------------------------------------------------------------|--------------------------------------------------------------------------------------------------------------------------------------------------------------------------------------------|------------------------|--------------|----------------------------------------|-------------------------------------------------|
| System unit                                                                                                                                                                                                                                                                                                         |                                                                                                                                                                                            | Un                     |              | NA                                     | NA                                              |
| <b>Fans</b>                                                                                                                                                                                                                                                                                                         |                                                                                                                                                                                            |                        |              |                                        |                                                 |
| Fan 1                                                                                                                                                                                                                                                                                                               |                                                                                                                                                                                            | Un-A1                  | Yes          | <a href="#">Part assembly diagrams</a> | <a href="#">Fan</a>                             |
| Fan 2                                                                                                                                                                                                                                                                                                               |                                                                                                                                                                                            | Un-A2                  | Yes          | <a href="#">Part assembly diagrams</a> | <a href="#">Fan</a>                             |
| <b>Power supplies</b>                                                                                                                                                                                                                                                                                               |                                                                                                                                                                                            |                        |              |                                        |                                                 |
| Power supply 1                                                                                                                                                                                                                                                                                                      | PWRSPLY                                                                                                                                                                                    | Un-E1                  | Yes          | <a href="#">Power parts</a>            | <a href="#">Power supply</a>                    |
| Power supply 2                                                                                                                                                                                                                                                                                                      | PWRSPLY                                                                                                                                                                                    | Un-E2                  | Yes          | <a href="#">Power parts</a>            | <a href="#">Power supply</a>                    |
| <b>Backplanes</b>                                                                                                                                                                                                                                                                                                   |                                                                                                                                                                                            |                        |              |                                        |                                                 |
| Input/output backplane with embedded:<br><ul style="list-style-type: none"> <li>• RIO Hub/HSL</li> <li>• RIO/HSL link</li> <li>• Ethernet controller</li> <li>• USB controller (AIX or Linux only)</li> <li>• IDE bridge (AIX or Linux only)</li> <li>• SCSI controllers (2)</li> <li>• Logic oscillator</li> </ul> | CLCKMOD<br>FRPORT<br>HSL_LNK<br>IOBRDG<br>IO_HUB<br>MA_BRDG<br>MABRCFG<br>MASBUSP<br>PCISYS<br>PRI_PCI<br>PIOCARD<br>SI_PHB<br>SIIOADP<br>SICNTRL<br>SYSBKPL<br>SPBUS<br>STORIOA<br>TOPORT | Un-P1                  | Yes          | <a href="#">28DA</a>                   | <a href="#">I/O backplane</a>                   |
| SCSI controller                                                                                                                                                                                                                                                                                                     |                                                                                                                                                                                            | Un-P1-T12              |              |                                        |                                                 |

## Service provider information

|                                                  |                                               |           |     |                 |                             |
|--------------------------------------------------|-----------------------------------------------|-----------|-----|-----------------|-----------------------------|
| 1 bus 0                                          |                                               |           |     |                 |                             |
| SCSI controller 1 bus 1                          |                                               | Un-P1-T13 |     |                 |                             |
| SCSI controller 2 bus 0                          |                                               | Un-P1-T14 |     |                 |                             |
| IDE controller                                   |                                               | Un-P1-T15 |     |                 |                             |
| Passthru card                                    |                                               | Un-P1     |     | 25F8            | I/O backplane               |
| I/O backplane assembly                           | NODEPL                                        | Un-P1     | Yes | 28DA            | System backplane            |
| Disk drive backplane                             |                                               | Un-P3     | Yes | 28DB            | Disk drive enclosure        |
| SCSI/IDE card                                    |                                               | Un-P3-C1  |     | 180A            | SCSI-IDE converter card     |
| Media drive backplane                            |                                               | Un-P4     | Yes | 28DC            | Media device enclosure      |
| <b>Ports</b>                                     |                                               |           |     |                 |                             |
| system port 2 (back of system unit)              |                                               | Un-P1-T1  |     |                 | NA                          |
| system port 1 (back of system unit)              |                                               | Un-P1-T2  |     |                 | NA                          |
| S1 system port (front of control panel)          |                                               | Un-P1-T2  |     |                 | NA                          |
| Rack indicator connector                         |                                               | Un-P1-T3  |     |                 | NA                          |
| Integrated 2-port USB port 1 (AIX or Linux only) |                                               | Un-P1-T4  |     |                 | NA                          |
| Integrated 2-port USB port 2 (AIX or Linux only) |                                               | Un-P1-T5  |     |                 | NA                          |
| Integrated dual 1 GB Ethernet controller-port 1  |                                               | Un-P1-T6  |     |                 | NA                          |
| Integrated dual 1 GB Ethernet controller-port 2  |                                               | Un-P1-T7  |     |                 | NA                          |
| RIO/HSL left connector                           | HSL_LNK<br>HSL2<br>HSL2_xx<br>HSLH<br>HSLH_xx | Un-P1-T8  | Yes | External cables | RIO/HSL cables (concurrent) |
| RIO/HSL right connector                          | HSL_LNK<br>HSL2<br>HSL2_xx<br>HSLH<br>HSLH_xx | Un-P1-T9  | Yes | External cables | RIO/HSL cables (concurrent) |
| System cable connector                           |                                               | Un-P1-T10 |     |                 | NA                          |
| <b>Processor and processor regulator</b>         |                                               |           |     |                 |                             |
| Processor card 1                                 | MEMCTLR<br>ANYPROC                            | Un-P2-C1  | Yes | Processor parts | System processor            |
| Processor card 2                                 | MEMCTLR<br>ANYPROC                            | Un-P2-C2  | Yes | Processor parts | System processor            |



Service provider information

|                                                            |                        |                             |     |                                                                |                                                     |
|------------------------------------------------------------|------------------------|-----------------------------|-----|----------------------------------------------------------------|-----------------------------------------------------|
| SMP processor cable                                        |                        | Un-P2-C1-T1 and Un-P2-C2-T1 |     | Model ESCALA PL 1650R-L+ and ESCALA PL 850R/PL 1650R/R+ cables | SMP processor cable                                 |
| Temperature sensor                                         |                        | Un -P2-C1 and Un -P2-C2     |     | Processor parts                                                | System processor                                    |
| Voltage regulator 1                                        |                        | Un-P2-C3                    | Yes | Power parts                                                    | Voltage regulator card assembly                     |
| Voltage regulator 2                                        |                        | Un-P2-C4                    | Yes | Power parts                                                    | Voltage regulator card assembly                     |
| Voltage regulator 3                                        |                        | Un-P2-C5                    | Yes | Power parts                                                    | Voltage regulator card assembly                     |
| VPD card                                                   |                        | Un-P1-T10                   |     | VPD parts                                                      | VPD card                                            |
| <b>Service processor</b>                                   |                        |                             |     |                                                                |                                                     |
| Service processor card                                     | SVCPROC                | Un-P1-C8                    | Yes | 28EA                                                           | Service processor assembly                          |
| Service processor cable                                    | I2CBUS                 | Un-P1-T10                   |     | Model ESCALA PL 1650R-L+ and ESCALA PL 850R/PL 1650R/R+ cables | Service processor cable                             |
| Time-of-day (TOD)                                          |                        | Un -P1-C8                   |     | 28EA                                                           | Service processor assembly                          |
| Time-of-day Battery                                        | TOD_BAT                | Un-P1-C8-E1                 |     | Power parts                                                    | Service processor time-of-day battery               |
| HMC 1 connector                                            |                        | Un-P1-C8-T1                 |     |                                                                | NA                                                  |
| HMC 2 connector                                            |                        | Un-P1-C8-T2                 |     |                                                                | NA                                                  |
| SPCN 0 connector                                           |                        | Un-P1-C8-T3                 |     |                                                                | NA                                                  |
| SPCN 1 connector                                           |                        | Un-P1-C8-T4                 |     |                                                                | NA                                                  |
| <b>Adapters</b>                                            |                        |                             |     |                                                                |                                                     |
| PCI adapter in slot 1                                      | PIOCARD MASBUS SLOTERR | Un-P1-C1                    | Yes | System parts                                                   | PCI adapter                                         |
| PCI adapter in slot 2                                      | PIOCARD MASBUS SLOTERR | Un-P1-C2                    | Yes | System parts                                                   | PCI adapter                                         |
| PCI adapter in slot 3                                      | PIOCARD MASBUS SLOTERR | Un-P1-C3                    | Yes | System parts                                                   | PCI adapter                                         |
| PCI adapter in slot 4                                      | PIOCARD MASBUS SLOTERR | Un-P1-C4                    | Yes | System parts                                                   | PCI adapter                                         |
| PCI adapter in slot 5                                      | PIOCARD MASBUS SLOTERR | Un-P1-C5                    | Yes | System parts                                                   | PCI adapter                                         |
| PCI adapter in slot 6                                      | PIOCARD MASBUS SLOTERR | Un-P1-C6                    | Yes | System parts                                                   | PCI adapter                                         |
| RIO/HSL adapter/<br>InfiniBand host channel adapter<br>ink | SI_CARD SICNTRL HCA    | Un-P1-C7                    | Yes | System parts                                                   | RIO/HSL adapter/<br>InfiniBand host channel adapter |

Service provider information

|                                        |                                               |                                                       |     |                 |                                                                                                                            |
|----------------------------------------|-----------------------------------------------|-------------------------------------------------------|-----|-----------------|----------------------------------------------------------------------------------------------------------------------------|
| RIO/HSL adapter connector              | HSL_LNK<br>HSL2<br>HSL2_xx<br>HSLH<br>HSLH_xx | Un-P1-C7-T1                                           | Yes | External cables | RIO/HSL cables (concurrent)                                                                                                |
| RIO/HSL adapter connector              | HSL_LNK<br>HSL2<br>HSL2_xx<br>HSLH<br>HSLH_xx | Un-P1-C7-T2                                           | Yes | External cables | RIO/HSL cables (concurrent)                                                                                                |
| Dual channel SCSI RAID enablement card |                                               | Un-P1-C9                                              |     | 5709            | RAID enablement card                                                                                                       |
| PCI bridge set 1                       | BRDGSET<br>BRDGST1                            | Un-P1                                                 |     | 28DA            | I/O backplane                                                                                                              |
| PCI bridge set 2                       | BRDGSET<br>BRDGST2                            | Un-P1<br>Un-P1-C1<br>Un-P1-C2                         |     |                 | Replace the I/O backplane and cards using the removal and replacement procedures corresponding to the locations indicated. |
| PCI bridge set 3                       | BRDGSET<br>BRDGST3                            | Un-P1<br>Un-P1-C3<br>Un-P1-C4<br>Un-P1-C5<br>Un-P1-C6 |     |                 | Replace the I/O backplane and cards using the removal and replacement procedures corresponding to the locations indicated. |
| <b>Memory modules</b>                  |                                               |                                                       |     |                 |                                                                                                                            |
| Memory module 1                        | MEMDIMM                                       | Un-P2-C1-C1                                           | Yes | Memory parts    | Memory module                                                                                                              |
| Memory module 2                        | MEMDIMM                                       | Un-P2-C1-C2                                           | Yes | Memory parts    | Memory module                                                                                                              |
| Memory module 3                        | MEMDIMM                                       | Un-P2-C1-C3                                           | Yes | Memory parts    | Memory module                                                                                                              |
| Memory module 4                        | MEMDIMM                                       | Un-P2-C1-C4                                           | Yes | Memory parts    | Memory module                                                                                                              |
| Memory module 5                        | MEMDIMM                                       | Un-P2-C1-C5                                           | Yes | Memory parts    | Memory module                                                                                                              |
| Memory module 6                        | MEMDIMM                                       | Un-P2-C1-C6                                           | Yes | Memory parts    | Memory module                                                                                                              |
| Memory module 7                        | MEMDIMM                                       | Un-P2-C1-C7                                           | Yes | Memory parts    | Memory module                                                                                                              |
| Memory module 8                        | MEMDIMM                                       | Un-P2-C1-C8                                           | Yes | Memory parts    | Memory module                                                                                                              |
| Memory module 1                        | MEMDIMM                                       | Un-P2-C2-C1                                           | Yes | Memory parts    | Memory module                                                                                                              |
| Memory module 2                        | MEMDIMM                                       | Un-P2-C2-C2                                           | Yes | Memory parts    | Memory module                                                                                                              |
| Memory module 3                        | MEMDIMM                                       | Un-P2-C2-C3                                           | Yes | Memory parts    | Memory module                                                                                                              |
| Memory module 4                        | MEMDIMM                                       | Un-P2-C2-C4                                           | Yes | Memory parts    | Memory module                                                                                                              |
| Memory module 5                        | MEMDIMM                                       | Un-P2-C2-C5                                           | Yes | Memory parts    | Memory module                                                                                                              |
| Memory module 6                        | MEMDIMM                                       | Un-P2-C2-C6                                           | Yes | Memory parts    | Memory module                                                                                                              |

Service provider information

|                                                                                                                                                                                                                                                |         |             |     |              |               |
|------------------------------------------------------------------------------------------------------------------------------------------------------------------------------------------------------------------------------------------------|---------|-------------|-----|--------------|---------------|
| Memory module 7                                                                                                                                                                                                                                | MEMDIMM | Un-P2-C2-C7 | Yes | Memory parts | Memory module |
| Memory module 8                                                                                                                                                                                                                                | MEMDIMM | Un-P2-C2-C8 | Yes | Memory parts | Memory module |
| <p><b>Note:</b> First quad of memory modules is plugged into memory module slots P2-Cx-C1, P2-Cx-C3, P2-Cx-C6, and P2-Cx-C8. Second quad of memory modules is plugged into memory module slots P2-Cx-C2, P2-Cx-C4, P2-Cx-C5, and P2-Cx-C7.</p> |         |             |     |              |               |
| <b>Control panel</b>                                                                                                                                                                                                                           |         |             |     |              |               |
| Control panel (bottom media bay)                                                                                                                                                                                                               |         | Un -D1      |     | 291D         | Control panel |
| <b>Server firmware</b>                                                                                                                                                                                                                         |         |             |     |              |               |
| Server firmware                                                                                                                                                                                                                                |         | Un-Y1       |     |              |               |

### Input/output adapter (IOA) assignment rules for

The following table provides information necessary to identify the input/output processor (IOP) to which IOAs are assigned. The left column indicates the bridge set in which IOA assignment is allowed. Use the right column to determine the IOP to which an IOA is assigned. The first position in the list must be an IOP. The remaining positions might be IOPs or IOAs. IOAs are assigned to the first IOP located to their left in the list. Although IOAs can be manually reassigned using system service tools (SST)/dedicated service tools (DST), the IOA assignments return to the default order after each initial program load (IPL).

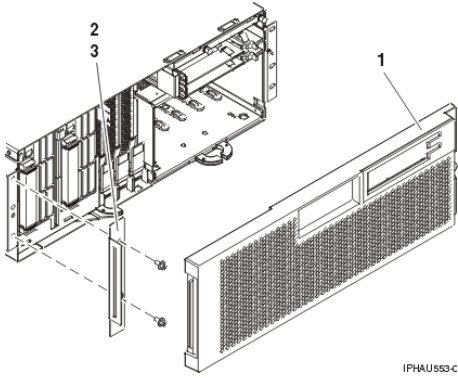
| Multi-adapter bridge domain / Peripheral Component Interconnect (PCI) bridge set | IOA assignment rules             |
|----------------------------------------------------------------------------------|----------------------------------|
| Adapters embedded in -P1 planar (no IOP)                                         | Embedded SCSI, embedded Ethernet |
| C1 - C2                                                                          | Embedded SCSI, C2                |
| C3 - C6                                                                          | C4, C5, C6                       |

Parent topic: [Finding part locations](#)

## Part assembly diagrams for model ESCALA PL 1650R-L+ and ESCALA PL 850R/PL 1650R/R+

This content covers the ESCALA PL 1650R-L+, 9406-570, and ESCALA PL 850R/PL 1650R/R+ models.

### Front cover assembly for model ESCALA PL 1650R-L+ and ESCALA PL 850R/PL 1650R/R+

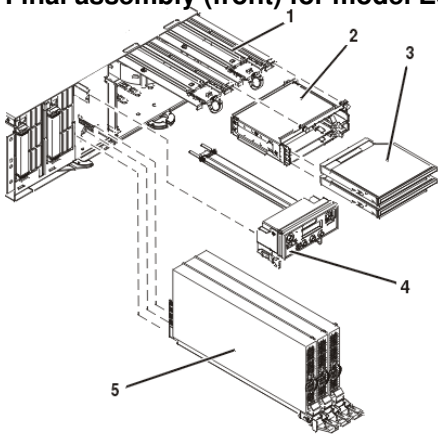


IPHAU553-c

Table 1. Front cover assembly part numbers for model ESCALA PL 1650R-L+ and ESCALA PL 850R/PL 1650R/R+

| Index number | Part number | Units | Description                   |
|--------------|-------------|-------|-------------------------------|
| 1            | 39J1736     | 1     | Front cover assembly          |
| 2            | 97P4698     | 1     | Bracket, front cover mounting |
| 3            | 04N6587     | 2     | Screw                         |

**Final assembly (front) for model ESCALA PL 1650R-L+ and ESCALA PL 850R/PL 1650R/R+**



IPHA1191-c

Table 2. Final assembly (front) part numbers for model ESCALA PL 1650R-L+ and ESCALA PL 850R/PL 1650R/R+

| Index number | Part number                                      | Units | Description                                                       |
|--------------|--------------------------------------------------|-------|-------------------------------------------------------------------|
| 1            | 39J0859                                          | 2     | Fan assembly                                                      |
| 2            | See <a href="#">Backplane parts</a>              | 1     | Removable media enclosure assembly (includes the media backplane) |
| 3            | See <a href="#">Removable media device parts</a> | 2     | Removable media assembly                                          |
| 3            | 97P9137                                          | AR    | Removable media filler assembly                                   |
| 4            | See <a href="#">Control panel parts</a>          | 1     | Control panel assembly                                            |

Service provider information

|   |                                 |   |                            |
|---|---------------------------------|---|----------------------------|
|   | 71P8467                         | 1 | Power button shield        |
| 5 | See <a href="#">Power parts</a> | 3 | Voltage regulator assembly |

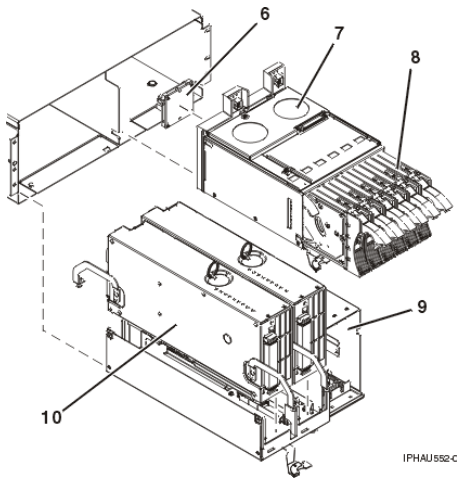


Table 3. Final assembly (front) part numbers for model ESCALA PL 1650R-L+ and ESCALA PL 850R/PL 1650R/R+, continued

| Index number | Part number                         | Units | Description                      |
|--------------|-------------------------------------|-------|----------------------------------|
| 6            | 03N4811                             | 1     | SCSI-IDE converter card assembly |
| 7            | See <a href="#">Backplane parts</a> | 1     | Disk drive backplane             |
| 8            | See <a href="#">Disk unit parts</a> | AR    | Disk drive assembly              |
|              | 97P4179                             | AR    | Disk drive filler assembly       |
| 9            | See <a href="#">Backplane parts</a> | 1     | System processor backplane       |
| 10           | See <a href="#">Processor parts</a> | 2     | System processor assembly        |
|              | See <a href="#">Memory parts</a>    | AR    | Memory DIMM                      |

**Final assembly (back) for model ESCALA PL 1650R-L+ and ESCALA PL 850R/PL 1650R/R+**

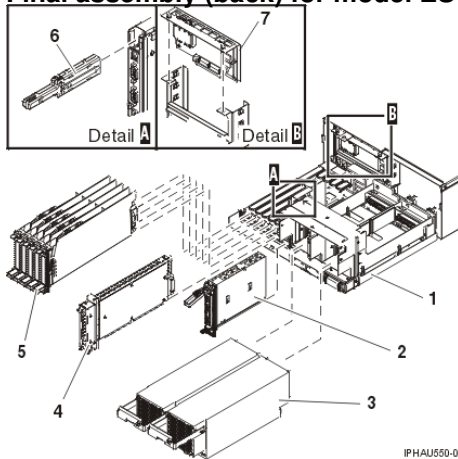


Table 4. Final assembly (back) part numbers for model ESCALA PL 1650R-L+ and ESCALA PL 850R/PL 1650R/R+

| Index number | Part number                         | Units | Description                                |
|--------------|-------------------------------------|-------|--------------------------------------------|
| 1            | See <a href="#">Backplane parts</a> | 1     | I/O backplane assembly                     |
| 2            | See <a href="#">Processor parts</a> | 1     | Service processor assembly                 |
| 2            | 97P5044                             | AR    | Service processor filler card              |
| 3            | See <a href="#">Power parts</a>     | 2     | Power supply assembly                      |
| 4            | See <a href="#">Bus parts</a>       | AR    | RIO card assembly                          |
| 5            | 21P8331                             | AR    | PCI adapter assembly                       |
|              | 97P4918                             | AR    | Short PCI adapter assembly (Un-P1-C6 only) |
| 6            | See <a href="#">VPD parts</a>       | 1     | VPD card                                   |
|              | 97P6687                             | AR    | VPD card filler                            |
| 7            | See <a href="#">Storage parts</a>   | 1     | RAID enablement card assembly              |

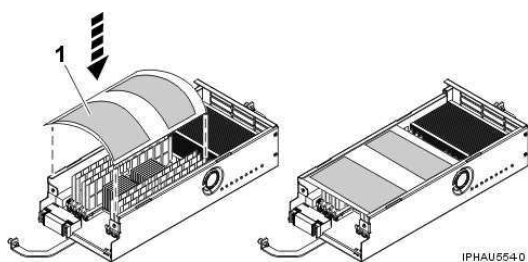


Table 5. ESCALA PL 850R/PL 1650R/R+ plastic shield.

| Index number | Part number | Units | Description    |
|--------------|-------------|-------|----------------|
| 1            | 97P6896     | 1     | Plastic shield |

Parent topic: [Part assembly diagrams](#)

## Exchanging the I/O backplane in the model ESCALA PL 1650R-L+ and ESCALA PL 850R/PL 1650R/R+

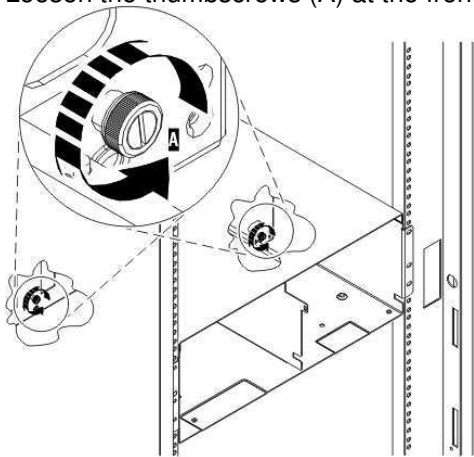
To remove the I/O backplane from the model ESCALA PL 1650R-L+ and ESCALA PL 850R/PL 1650R/R+, perform the following procedure.

**Attention:** Before continuing with this procedure, check the SMP processor cable connections and the service processor cable connections. Reference codes, which can be caused by an SMP processor cable or a service processor cable connection, might instruct you to unnecessarily replace the I/O backplane or the service processor card. Before replacing an I/O backplane or a service processor card, check the SMP processor cable and the service processor cable connections (if the cables are installed) by using the following procedure:

1. If the server is started, stop all the system units that are connected by SMP processor cables and service processor cables.
2. Check each connection by removing the cable connectors from the server and checking for any damage to the connectors or cables.
3. Reconnect the SMP processor cables and service processor cables. Ensure that each connector is fully seated and secured into position.
4. Verify the server operation. If the problem is not corrected, continue with this procedure.
  - a. Power off the system (see [Powering on and powering off](#)).
  - b. Disconnect the plugs to each power supply.
  - c. Perform the following from the back of the system:
    - i. Remove and label all cables from the back of the system.
    - ii. Remove the PCI adapter cards and empty cassettes from slots 1 through 6 (see [model ESCALA PL 850R/PL 1650R/R+ PCI adapters and cassettes](#)).
    - iii. [Remove the model ESCALA PL 850R/PL 1650R/R+ power supplies](#).
    - iv. Remove the RIO card if it is installed in position -C7 (see [RIO card](#)).

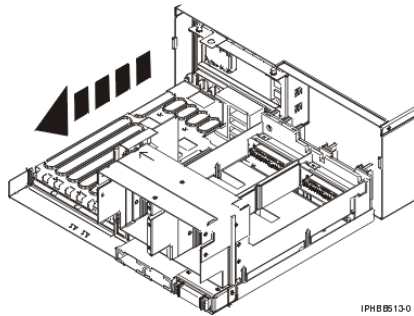
**Note:** When completing the next step, you only need to remove the service processor assembly temporarily. Therefore you do not need to record the service processor settings or remove the time-of-day battery. If you remove the time-of-day battery some of the service processor settings might be lost.

- v. [Remove the model ESCALA PL 850R/PL 1650R/R+ service processor assembly and time-of-day battery](#).
  - vi. Remove the VPD card (see [Exchanging the VPD card in the model ESCALA PL 1650R-L+ and ESCALA PL 850R/PL 1650R/R+](#)).
5. [Remove the model ESCALA PL 850R/PL 1650R/R+ front cover](#).
6. Perform the following from the front of the system:
  - a. [Remove the model ESCALA PL 850R/PL 1650R/R+ control panel](#).
  - b. Remove the fans (see [Remove the model ESCALA PL 850R/PL 1650R/R+ system unit fan](#)).
  - c. [Remove the model ESCALA PL 850R/PL 1650R/R+ media-device enclosure](#).
  - d. [Remove the model ESCALA PL 850R/PL 1650R/R+ disk drive enclosure](#).
  - e. Remove the voltage regulator card assembly (see [model ESCALA PL 850R/PL 1650R/R+ voltage regulator assembly](#)).
  - f. [Remove the model ESCALA PL 850R/PL 1650R/R+ system processor assembly](#).
7. Loosen the thumbscrews (A) at the front of the backplane.



IPH85511-0

8. Slide the backplane from the enclosure.



9. To install the new I/O backplane, reverse this procedure.

**Note:** After installing the backplane securely tighten both thumbscrews. Step 10 must be completed before attempting to power on or IPL the system. If step 10 is not completed before attempting to power on or IPL the system, bus renumbering may occur.

10. Perform the following to set the configuration ID and MTMS values:
- Use the Hardware Management Console (HMC) or PC Web browser to access the ASMI (see [Accessing the Advanced System Management Interface](#)).

**Note:** The machine type-model-serial (MTMS) value must be set to match the original value found on a label affixed to the side of the enclosure. It cannot be left with the new serial number of the newly replaced I/O backplane, if it is the customer's LPAR I/O assignments will be incorrect. Updating the MTMS value keeps the configuration and error information in sync, and is used by the system when creating the location codes. This must be done using the ASMI, not with the control panel. Refer to [Managing the Advanced System Management Interface \(ASMI\)](#) for information on setting up the ASMI, and [Managing your server using the Advanced System Management Interface for information on using the ASMI](#), for information on using the ASMI, including updating the system configuration settings.

- To update the processing unit power control network ID, follow the instructions in [Changing processing unit power control network identifier](#). Change the identifier to one of the following:
    - ◇ B2 for a single enclosure system
    - ◇ B3 for a multiple enclosure system
  - To change the system enclosure type, follow the instructions in [Setting the system enclosure type](#).
11. Reactivate any Power On Demand devices using the ASMI. Refer to [Using on-demand utilities](#). This ends the procedure.

**Parent topic:** [Removing and replacing parts in the model ESCALA PL 1650R-L+, 9406-570, and ESCALA PL 850R/PL 1650R/R+](#)

## Exchanging the VPD card in the model ESCALA PL 1650R-L+ and ESCALA PL 850R/PL 1650R/R+

**Attention:** The VPD card contains data which is vital to system operation:

- Machine type, model, and serial number
- System brand
- System unique ID (SUID)
- Activation codes for Power On Demand and Virtualization Engine Technologies (if applicable)

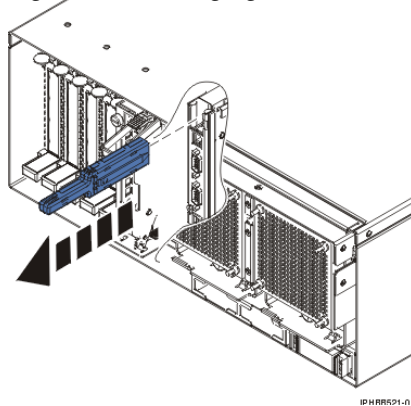
If the VPD card is replaced, this data must be programmed into the replacement VPD card. If the system is still functional prior to the replacement of the VPD card, view and record the System unique ID (SUID).



New, replacement activation codes for Power On Demand and Virtualization Engine Technologies will have to be generated. The original activation codes for the system cannot be reused. Contact your next level of support for new activation codes.

To exchange the VPD card in the model ESCALA PL 1650R-L+ and ESCALA PL 850R/PL 1650R/R+, perform the following procedure:

Figure 1. Exchanging the VPD card in the model ESCALA PL 1650R-L+ and ESCALA PL 850R/PL 1650R/R+



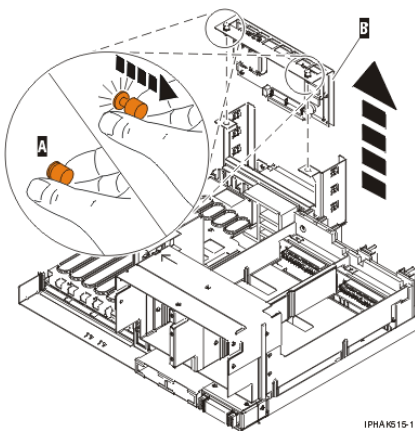
1. If you are removing the VPD card as part of another procedure, continue to the next step. If you are removing the VPD card because it is not operational, verify that it is the failing part. See [Identify a failing part](#).
2. If the system is still functional and you are replacing the VPD card with a new VPD card, view and record the System unique ID (SUID). This can be done by using a Hardware Management Console (HMC) or PC to access the ASMI. Refer to [Accessing the Advanced System Management Interface](#) for information about setting up the ASMI, and [Managing your server using the Advanced System Management Interface](#) for information about using the ASMI. For further information, see [Viewing vital product data](#).
3. Power off the system. To review the power off procedure, go to [Powering on and powering off](#).
4. Disconnect the line cords to each power supply.
5. Pull out the VPD card by the blue handle.
6. To install a VPD card, reverse this procedure. Insert the VPD card with the key oriented to the right as shown and push until fully seated.
7. If you replaced the VPD card as part of another procedure, return to that procedure now.
8. Connect the line cords to each power supply.
9. Use ASMI to set the system brand and system identifiers. This can be done by using a Hardware Management Console (HMC) or PC to access the ASMI. Refer to [Accessing the Advanced System Management Interface](#) for information about setting up the ASMI, and [Managing your server using the Advanced System Management Interface](#) for information about using the ASMI. Update the system configuration settings. For further information, see [Programming vital product data](#).
10. If the customer had Power On Demand activation codes, obtain new activation codes from your next level of support and enter the new codes. For more information, see [Working with Power On Demand](#).
11. If the customer had Virtualization Engine Technologies activation codes, obtain new activation codes from your next level of support and enter the new codes. For more information, see [Entering the activation code for Virtualization Engine technologies](#).
12. Power on the system. To review the power on procedure, go to [Powering on and powering off](#).
13. If you replaced the VPD card because it was not operational, verify that the new resource is functional. See [Verifying the repair](#). This ends the procedure.

**Parent topic:** [Removing and replacing parts in the model ESCALA PL 1650R-L+, 9406-570, and ESCALA PL 850R/PL 1650R/R+](#)

## Exchanging the RAID enablement card in the model ESCALA PL 1650R-L+ and ESCALA PL 850R/PL 1650R/R+

To remove the RAID enablement card, perform the following procedure.

1. Remove the I/O backplane (see [Exchanging the I/O backplane in the model ESCALA PL 1650R-L+ and ESCALA PL 850R/PL 1650R/R+](#)).
2. Place the I/O backplane on a flat surface.
3. Unlock the restraining pins (A) located at the top of the RAID enablement card bracket (B).
4. Lift the RAID enablement card and bracket from the enclosure.
5. To replace the RAID enablement card, reverse the steps in this removal procedure. This ends the procedure.



**Parent topic:** [Removing and replacing parts in the model ESCALA PL 1650R-L+, 9406-570, and ESCALA PL 850R/PL 1650R/R+](#)

## Locations model 5/75

**Note:** The known logical location codes for this unit are listed next to the corresponding physical location in the following information. If you are working with a logical location code for this unit and it is not listed in the following information, contact your next level of support.

The following diagrams show field replaceable unit (FRU) layout in the system. Use these diagrams with the following tables. To find bulk power assembly (BPA) location information for the 57/92 rack, see [Locations model ESCALA PL 3250R, PL 3250R+, ESCALA PL 6450 or PL 6450R+](#).

Figure 1. Bulk power assembly (BPA)

Service provider information

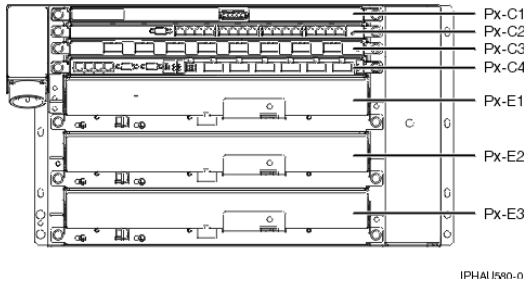


Figure 2. Bulk power jumper (BPJ)

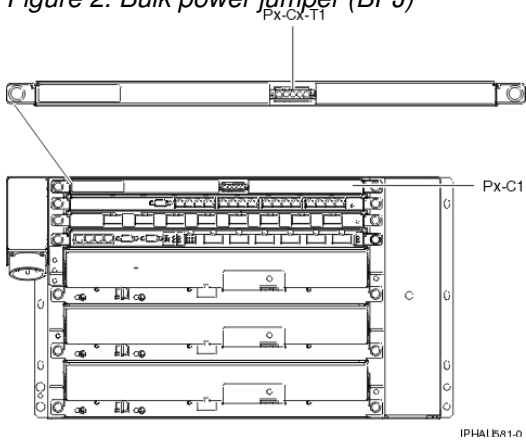


Figure 3. Bulk power hub (BPH)

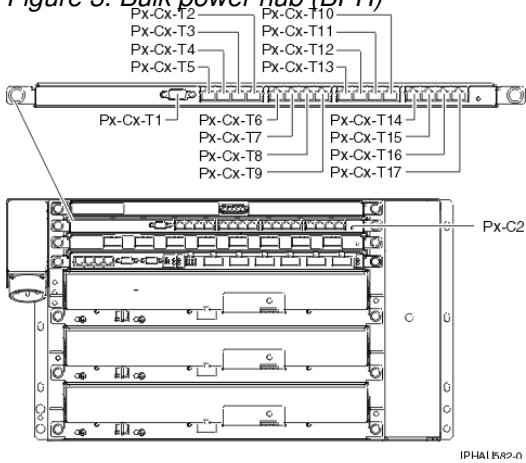


Figure 4. Bulk power controller (BPC)

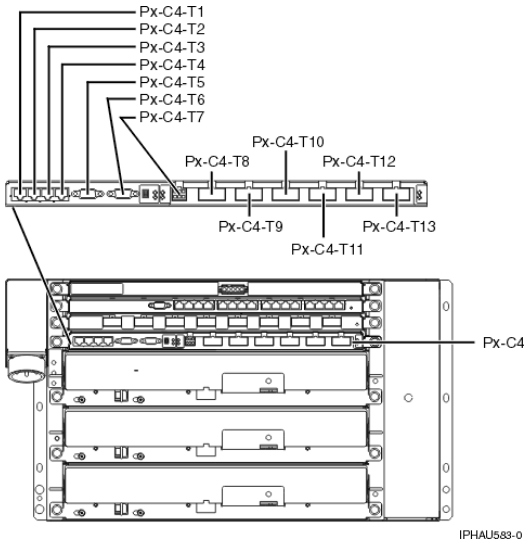


Figure 5. Bulk power regulator (BPR)

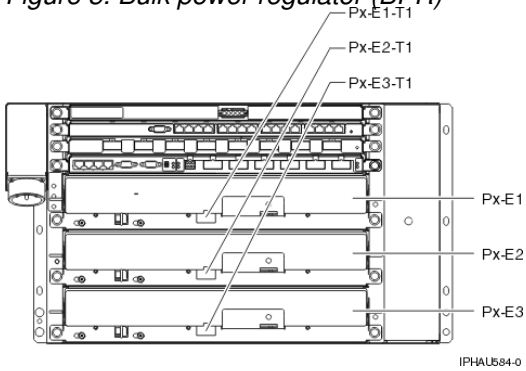


Figure 6. Back view of the system with four PCI adapters installed

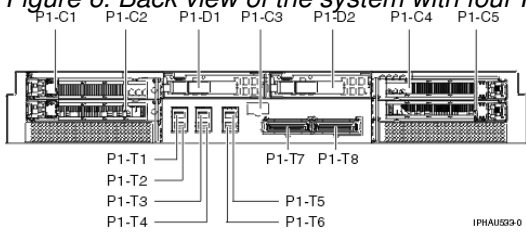


Figure 7. Back view of the system with two PCI adapters and two GX adapters installed

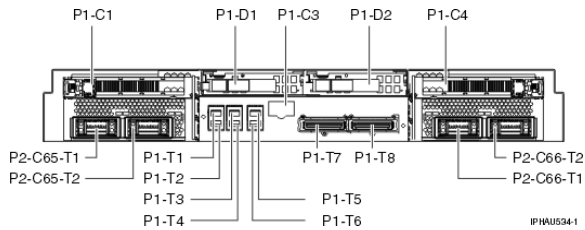
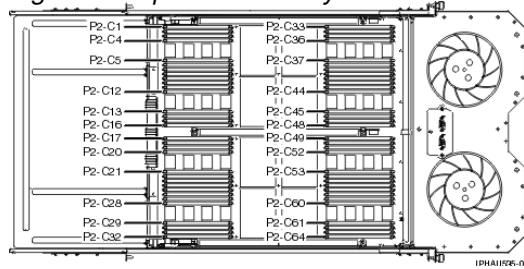


Figure 8. Top view of the system



The following table provides location codes for parts that make up the server.

**Attention:** After replacing any part on a server or expansion unit, perform [Verifying the repair](#).

Table 1. Bulk power assembly (BPA) FRU locations and failing components

| Failing item name                        | Symbolic FRU name | Physical location code | Link to part number         | Failing item removal and replacement procedures                |
|------------------------------------------|-------------------|------------------------|-----------------------------|----------------------------------------------------------------|
| System unit bulk power assembly (BPA)    |                   | Un                     |                             |                                                                |
| Bulk power jumper (BPJ)                  |                   |                        |                             |                                                                |
| Bulk power jumper (BPJ) 1A (front)       |                   | Un-P1-C1               | <a href="#">Power parts</a> | <a href="#">Removing and replacing parts in the model 5/75</a> |
| Bulk power jumper (BPJ) 1A connector J00 |                   | Un-P1-C1-T1            |                             |                                                                |
| Bulk power jumper (BPJ) 1B (back)        |                   | Un-P2-C1               | <a href="#">Power parts</a> | <a href="#">Removing and replacing parts in the model 5/75</a> |
| Bulk power jumper (BPJ) 1B connector J00 |                   | Un-P2-C1-T1            |                             |                                                                |

|                                                                                                                                                     |  |              |                                                |
|-----------------------------------------------------------------------------------------------------------------------------------------------------|--|--------------|------------------------------------------------|
| Bulk power hub (BPH) Where:                                                                                                                         |  |              |                                                |
| <ul style="list-style-type: none"> <li>• Bulk power hub (BPH) A (front) is Un-P1-C2</li> <li>• Bulk power hub (BPH) B (back) is Un-P2-C2</li> </ul> |  |              |                                                |
| Bulk power hub (BPH) x                                                                                                                              |  | Un-Px-C2     | Power parts                                    |
|                                                                                                                                                     |  |              | Removing and replacing parts in the model 5/75 |
| Bulk power hub (BPH) x connector J00                                                                                                                |  | Un-Px-C2-T1  |                                                |
| Bulk power hub (BPH) x connector J01                                                                                                                |  | Un-Px-C2-T2  |                                                |
| Bulk power hub (BPH) x connector J02                                                                                                                |  | Un-Px-C2-T3  |                                                |
| Bulk power hub (BPH) x connector J03                                                                                                                |  | Un-Px-C2-T4  |                                                |
| Bulk power hub (BPH) x connector J04                                                                                                                |  | Un-Px-C2-T5  |                                                |
| Bulk power hub (BPH) x connector J05                                                                                                                |  | Un-Px-C2-T6  |                                                |
| Bulk power hub (BPH) x connector J06                                                                                                                |  | Un-Px-C2-T7  |                                                |
| Bulk power hub (BPH) x connector J07                                                                                                                |  | Un-Px-C2-T8  |                                                |
| Bulk power hub (BPH) x connector J08                                                                                                                |  | Un-Px-C2-T9  |                                                |
| Bulk power hub (BPH) x connector J09                                                                                                                |  | Un-Px-C2-T10 |                                                |
| Bulk power hub (BPH) x connector J10                                                                                                                |  | Un-Px-C2-T11 |                                                |
| Bulk power hub (BPH) x connector J11                                                                                                                |  | Un-Px-C2-T12 |                                                |
| Bulk power hub (BPH) x connector J12                                                                                                                |  | Un-Px-C2-T13 |                                                |
| Bulk power hub (BPH) x connector J13                                                                                                                |  | Un-Px-C2-T14 |                                                |
| Bulk power hub (BPH) x connector J14                                                                                                                |  | Un-Px-C2-T15 |                                                |
| Bulk power hub (BPH) x connector J15                                                                                                                |  | Un-Px-C2-T16 |                                                |
| Bulk power hub (BPH) x connector J16                                                                                                                |  | Un-Px-C2-T17 |                                                |
| Bulk power distribution (BPD) Where:                                                                                                                |  |              |                                                |

|                                                                                                                                                                         |  |              |             |                                                |
|-------------------------------------------------------------------------------------------------------------------------------------------------------------------------|--|--------------|-------------|------------------------------------------------|
| <ul style="list-style-type: none"> <li>• Bulk power distribution (BPD) 1A (front) is Un-P1-C3</li> <li>• Bulk power distribution (BPD) 1B (back) is Un-P2-C3</li> </ul> |  |              |             |                                                |
| Bulk power distribution (BPD) x                                                                                                                                         |  | Un-Px-C3     | Power parts | Removing and replacing parts in the model 5/75 |
| Bulk power distribution (BPD) x connector J00                                                                                                                           |  | Un-Px-Cx-T1  |             |                                                |
| Bulk power distribution (BPD) x connector J01                                                                                                                           |  | Un-Px-Cx-T2  |             |                                                |
| Bulk power distribution (BPD) x connector J02                                                                                                                           |  | Un-Px-Cx-T3  |             |                                                |
| Bulk power distribution (BPD) x connector J03                                                                                                                           |  | Un-Px-Cx-T4  |             |                                                |
| Bulk power distribution (BPD) x connector J04                                                                                                                           |  | Un-Px-Cx-T5  |             |                                                |
| Bulk power distribution (BPD) x connector J05                                                                                                                           |  | Un-Px-Cx-T6  |             |                                                |
| Bulk power distribution (BPD) n connector J06                                                                                                                           |  | Un-Px-Cx-T7  |             |                                                |
| Bulk power distribution (BPD) x connector J07                                                                                                                           |  | Un-Px-Cx-T8  |             |                                                |
| Bulk power distribution (BPD) x connector J08                                                                                                                           |  | Un-Px-Cx-T9  |             |                                                |
| Bulk power distribution (BPD) x connector J09                                                                                                                           |  | Un-Px-Cx-T10 |             |                                                |
| Bulk power controller (BPC) Where:                                                                                                                                      |  |              |             |                                                |
| <ul style="list-style-type: none"> <li>• Bulk power controller (BPC) A (front) is Un-P1-C4</li> <li>• Bulk power controller (BPC) B (back) is Un-P2-C4</li> </ul>       |  |              |             |                                                |
| Bulk power controller (BPC) x                                                                                                                                           |  | Un-Px-C4     | Power parts | Removing and replacing parts in the model 5/75 |
| Bulk power controller (BPC) x connector J00A                                                                                                                            |  | Un-Px-C4-T1  |             | Removing and replacing parts in the model 5/75 |
| Bulk power controller (BPC) x connector                                                                                                                                 |  | Un-Px-C4-T2  |             |                                                |

Service provider information

|                                              |  |              |             |                                                |
|----------------------------------------------|--|--------------|-------------|------------------------------------------------|
| J00B                                         |  |              |             |                                                |
| Bulk power controller (BPC) x connector J00C |  | Un-Px-C4-T3  |             |                                                |
| Bulk power controller (BPC) x connector J00D |  | Un-Px-C4-T4  |             |                                                |
| Bulk power controller (BPC) x connector J01  |  | Un-Px-C4-T5  |             |                                                |
| Bulk power controller (BPC) x connector J02  |  | Un-Px-C4-T6  |             |                                                |
| Bulk power controller (BPC) x connector J03  |  | Un-Px-C4-T7  |             |                                                |
| Bulk power controller (BPC) x connector J04  |  | Un-Px-C4-T8  |             |                                                |
| Bulk power controller (BPC) x connector J05  |  | Un-Px-C4-T9  |             |                                                |
| Bulk power controller (BPC) x connector J06  |  | Un-Px-C4-T10 |             |                                                |
| Bulk power controller (BPC) x connector J07  |  | Un-Px-C4-T11 |             |                                                |
| Bulk power controller (BPC) x connector J08  |  | Un-Px-C4-T12 |             |                                                |
| Bulk power controller (BPC) x connector J09  |  | Un-Px-C4-T13 |             |                                                |
| Bulk power regulator (BPR)                   |  |              |             |                                                |
| Bulk power regulator (BPR) 3A (front)        |  | Un-P1-E1     | Power parts | Removing and replacing parts in the model 5/75 |
| Bulk power regulator (BPR) 3A connector J00  |  | Un-P1-E1-T1  |             |                                                |
| Bulk power regulator (BPR) 2A (front)        |  | Un-P1-E2     | Power parts | Removing and replacing parts in the model 5/75 |



Service provider information

|                                             |  |             |             |                                                |
|---------------------------------------------|--|-------------|-------------|------------------------------------------------|
| Bulk power regulator (BPR) 2A connector J00 |  | Un-P1-E2-T1 |             |                                                |
| Bulk power regulator (BPR) 1A (front)       |  | Un-P1-E3    | Power parts | Removing and replacing parts in the model 5/75 |
| Bulk power regulator (BPR) 1A connector J00 |  | Un-P1-E3-T1 |             |                                                |
| Bulk power regulator (BPR) 3B (back)        |  | Un-P2-E1    | Power parts | Removing and replacing parts in the model 5/75 |
| Bulk power regulator (BPR) 3B connector J00 |  | Un-P2-E1-T1 |             |                                                |
| Bulk power regulator (BPR) 2B (back)        |  | Un-P2-E2    | Power parts | Removing and replacing parts in the model 5/75 |
| Bulk power regulator (BPR) 2B connector J00 |  | Un-P2-E2-T1 |             |                                                |
| Bulk power regulator (BPR) 1B (back)        |  | Un-P2-E3    | Power parts | Removing and replacing parts in the model 5/75 |
| Bulk power regulator (BPR) 1B connector J00 |  | Un-P2-E3-T1 |             |                                                |
| Fans                                        |  |             |             |                                                |
| Bulk power fan (BPF) A (front)              |  | Un-A1       | Power parts | Removing and replacing parts in the model 5/75 |
| Bulk power fan (BPF) B (back)               |  | Un-A2       | Power parts | Removing and replacing parts in the model 5/75 |
| Emergency power off (EPO)                   |  |             |             |                                                |
| Emergency power off (EPO)                   |  | Un-D1       | Power parts | Removing and replacing parts in the model 5/75 |
| Emergency power off (EPO) connector J00     |  | Un-D1-T1    |             |                                                |
| Emergency power off (EPO) J01               |  | Un-D1-T2    |             |                                                |

Table 2. Processor subsystem assembly FRU locations and failing components

| Failing item name | Symbolic failing item | Physical location code | Identify LED | Link to part number | Failing item removal and replacement |
|-------------------|-----------------------|------------------------|--------------|---------------------|--------------------------------------|
|-------------------|-----------------------|------------------------|--------------|---------------------|--------------------------------------|

Service provider information

|                               | name                                                                                                                                                                                                                                           |          |     |             | procedures                                     |
|-------------------------------|------------------------------------------------------------------------------------------------------------------------------------------------------------------------------------------------------------------------------------------------|----------|-----|-------------|------------------------------------------------|
| System unit                   |                                                                                                                                                                                                                                                | Un       |     |             |                                                |
| Fan                           |                                                                                                                                                                                                                                                |          |     |             |                                                |
| Fan                           |                                                                                                                                                                                                                                                | Un-A1    | Yes | Power parts | Removing and replacing parts in the model 5/75 |
| Fan connector 1               |                                                                                                                                                                                                                                                | Un-A1-T1 |     |             |                                                |
| Fan connector 2               |                                                                                                                                                                                                                                                | Un-A1-T2 |     |             |                                                |
| Power supply                  |                                                                                                                                                                                                                                                |          |     |             |                                                |
| Power supply                  |                                                                                                                                                                                                                                                | Un-E1    | Yes | Power parts | Removing and replacing parts in the model 5/75 |
| Power supply connector 1      |                                                                                                                                                                                                                                                | Un-E1-T1 |     |             |                                                |
| Power supply connector 2      |                                                                                                                                                                                                                                                | Un-E1-T2 |     |             |                                                |
| Backplane                     |                                                                                                                                                                                                                                                |          |     |             |                                                |
| System backplane              | CLCKMOD<br>HSL_LNK<br>IO_HUB<br>IOBRDG<br>Multi-adapter bridge (all)<br>Service processor<br>RIO Hub/HSS<br>NIC<br>RIO I/O Bridge<br>RIO link<br>Ethernet controller<br>SCSI controller<br>Logic oscillator<br>InfiniBand Host Channel Adapter | Un-P1    | Yes | 28F0        | Removing and replacing parts in the model 5/75 |
| Time-of-day battery           | TOD_BAT                                                                                                                                                                                                                                        | Un-P1-E1 |     | Power parts | Removing and replacing parts in the model 5/75 |
| Processor backplane           | ANYPROC<br>MEMBRD<br>MEMCTLR<br>• System processor                                                                                                                                                                                             | Un-P2    | Yes |             | Removing and replacing parts in the model 5/75 |
| System backplane ports        |                                                                                                                                                                                                                                                |          |     |             |                                                |
| Ethernet Port 1 (top left)    |                                                                                                                                                                                                                                                | Un-P1-T1 |     |             |                                                |
| Ethernet Port 2 (bottom left) |                                                                                                                                                                                                                                                | Un-P1-T2 |     |             |                                                |
| Ethernet Port 3 (top middle)  |                                                                                                                                                                                                                                                | Un-P1-T3 |     |             |                                                |
| Ethernet Port 4 (bottom)      |                                                                                                                                                                                                                                                | Un-P1-T4 |     |             |                                                |

## Service provider information

|                                                                                  |                                         |          |     |              |                                                                                                                               |
|----------------------------------------------------------------------------------|-----------------------------------------|----------|-----|--------------|-------------------------------------------------------------------------------------------------------------------------------|
| middle)                                                                          |                                         |          |     |              |                                                                                                                               |
| HMC 1 (top right)                                                                |                                         | Un-P1-T5 | Yes |              |                                                                                                                               |
| HMC 2 (bottom right)                                                             |                                         | Un-P1-T6 | Yes |              |                                                                                                                               |
| RIO connector (left connector)                                                   |                                         | Un-P1-T7 | Yes |              | RIO cables concurrent                                                                                                         |
| RIO connector (right connector)                                                  |                                         | Un-P1-T8 | Yes |              | RIO cables concurrent                                                                                                         |
| Adapters                                                                         |                                         |          |     |              |                                                                                                                               |
| PCI adapter in slot 1                                                            | PIOCARD<br>MASBUS<br>SLOTERR            | Un-P1-C1 | Yes | System parts | PCI adapter                                                                                                                   |
| PCI adapter in slot 2                                                            | PIOCARD<br>MASBUS<br>SLOTERR            | Un-P1-C2 | Yes | System parts | PCI adapter                                                                                                                   |
| <b>Note:</b><br>Un-P1-C2 and Un-P2-C65 cannot be in the system at the same time. |                                         |          |     |              |                                                                                                                               |
| VPD card                                                                         | CAPACTY<br>PIOCARD<br>MASBUS<br>SLOTERR | Un-P1-C3 | Yes | System parts | Removing and replacing parts in the model 5/75                                                                                |
| PCI adapter in slot 4                                                            | PIOCARD<br>MASBUS<br>SLOTERR            | Un-P1-C4 | Yes | System parts | PCI adapter                                                                                                                   |
| PCI adapter in slot 5                                                            | PIOCARD<br>MASBUS<br>SLOTERR            | Un-P1-C5 | Yes | System parts | PCI adapter                                                                                                                   |
| <b>Note:</b><br>Un-P1-C5 and Un-P2-C66 cannot be in the system at the same time. |                                         |          |     |              |                                                                                                                               |
| PCI bridge set 1                                                                 | BRDGSET<br>BRDGST1                      |          |     |              | Replace the system backplane and cards using the removal and replacement procedures corresponding to the locations indicated. |
| PCI bridge set 2                                                                 | BRDGSET<br>BRDGST2                      |          |     |              | Replace the system backplane and cards using the removal and replacement procedures corresponding to the                      |

## Service provider information

|                                                                                  |         |              |     |              |                                                |
|----------------------------------------------------------------------------------|---------|--------------|-----|--------------|------------------------------------------------|
|                                                                                  |         |              |     |              | locations indicated.                           |
| GX adapter                                                                       |         | Un-P2-C65    | Yes |              | Removing and replacing parts in the model 5/75 |
| <b>Note:</b><br>Un-P1-C2 and Un-P2-C65 cannot be in the system at the same time. |         |              |     |              |                                                |
| GX adapter connector port 1 (left)                                               |         | Un-P2-C65-T1 | Yes |              |                                                |
| GX adapter connector port 0 (right)                                              |         | Un-P2-C65-T2 | Yes |              |                                                |
| GX adapter                                                                       |         | Un-P2-C66    | Yes |              | Removing and replacing parts in the model 5/75 |
| <b>Note:</b><br>Un-P1-C5 and Un-P2-C66 cannot be in the system at the same time. |         |              |     |              |                                                |
| GX adapter connector port 1 (left)                                               |         | Un-P2-C66-T1 | Yes |              |                                                |
| GX adapter connector port 0 (right)                                              |         | Un-P2-C66-T2 | Yes |              |                                                |
| Memory modules                                                                   |         |              |     |              |                                                |
| Memory module 1                                                                  | MEMDIMM | Un-P2-C1     | Yes | Memory parts | Removing and replacing parts in the model 5/75 |
| Memory module 2                                                                  | MEMDIMM | Un-P2-C2     | Yes | Memory parts | Removing and replacing parts in the model 5/75 |
| Memory module 3                                                                  | MEMDIMM | Un-P2-C3     | Yes | Memory parts | Removing and replacing parts in the model 5/75 |
| Memory module 4                                                                  | MEMDIMM | Un-P2-C4     | Yes | Memory parts | Removing and replacing parts in the model 5/75 |
| Memory module 5                                                                  | MEMDIMM | Un-P2-C5     | Yes | Memory parts | Removing and replacing parts in the model 5/75 |
| Memory module 6                                                                  | MEMDIMM | Un-P2-C6     | Yes | Memory parts | Removing and replacing parts in the model 5/75 |
| Memory module 7                                                                  | MEMDIMM | Un-P2-C7     | Yes | Memory parts | Removing and replacing parts in the model 5/75 |
| Memory module 8                                                                  | MEMDIMM | Un-P2-C8     | Yes | Memory parts | Removing and replacing parts in the model 5/75 |
| Memory module 9                                                                  | MEMDIMM | Un-P2-C9     | Yes | Memory parts | Removing and replacing parts in the model 5/75 |
| Memory module 10                                                                 | MEMDIMM | Un-P2-C10    | Yes | Memory parts | Removing and replacing parts in the model 5/75 |

## Service provider information

|                  |         |           |     |              |                                                |
|------------------|---------|-----------|-----|--------------|------------------------------------------------|
| Memory module 11 | MEMDIMM | Un-P2-C11 | Yes | Memory parts | Removing and replacing parts in the model 5/75 |
| Memory module 12 | MEMDIMM | Un-P2-C12 | Yes | Memory parts | Removing and replacing parts in the model 5/75 |
| Memory module 13 | MEMDIMM | Un-P2-C13 | Yes | Memory parts | Removing and replacing parts in the model 5/75 |
| Memory module 14 | MEMDIMM | Un-P2-C14 | Yes | Memory parts | Removing and replacing parts in the model 5/75 |
| Memory module 15 | MEMDIMM | Un-P2-C15 | Yes | Memory parts | Removing and replacing parts in the model 5/75 |
| Memory module 16 | MEMDIMM | Un-P2-C16 | Yes | Memory parts | Removing and replacing parts in the model 5/75 |
| Memory module 17 | MEMDIMM | Un-P2-C17 | Yes | Memory parts | Removing and replacing parts in the model 5/75 |
| Memory module 18 | MEMDIMM | Un-P2-C18 | Yes | Memory parts | Removing and replacing parts in the model 5/75 |
| Memory module 19 | MEMDIMM | Un-P2-C19 | Yes | Memory parts | Removing and replacing parts in the model 5/75 |
| Memory module 20 | MEMDIMM | Un-P2-C20 | Yes | Memory parts | Removing and replacing parts in the model 5/75 |
| Memory module 21 | MEMDIMM | Un-P2-C21 | Yes | Memory parts | Removing and replacing parts in the model 5/75 |
| Memory module 22 | MEMDIMM | Un-P2-C22 | Yes | Memory parts | Removing and replacing parts in the model 5/75 |
| Memory module 23 | MEMDIMM | Un-P2-C23 | Yes | Memory parts | Removing and replacing parts in the model 5/75 |
| Memory module 24 | MEMDIMM | Un-P2-C24 | Yes | Memory parts | Removing and replacing parts in the model 5/75 |
| Memory module 25 | MEMDIMM | Un-P2-C25 | Yes | Memory parts | Removing and replacing parts in the model 5/75 |
| Memory module 26 | MEMDIMM | Un-P2-C26 | Yes | Memory parts | Removing and replacing parts in the model 5/75 |
| Memory module 27 | MEMDIMM | Un-P2-C27 | Yes | Memory parts | Removing and replacing parts in the model 5/75 |
| Memory module 28 | MEMDIMM | Un-P2-C28 | Yes | Memory parts | Removing and replacing parts in the model 5/75 |
| Memory module 29 | MEMDIMM | Un-P2-C29 | Yes | Memory parts | Removing and replacing parts in the model 5/75 |
| Memory module 30 | MEMDIMM | Un-P2-C30 | Yes | Memory parts | Removing and replacing parts in the model 5/75 |
| Memory module 31 | MEMDIMM | Un-P2-C31 | Yes | Memory parts | Removing and replacing parts in the model 5/75 |
| Memory module 32 | MEMDIMM | Un-P2-C32 | Yes | Memory parts | Removing and replacing parts in the model 5/75 |
| Memory module 33 | MEMDIMM | Un-P2-C33 | Yes | Memory parts | Removing and replacing parts in the model 5/75 |
| Memory module 34 | MEMDIMM | Un-P2-C34 | Yes | Memory parts | Removing and replacing parts in the model 5/75 |
| Memory module 35 | MEMDIMM | Un-P2-C35 | Yes | Memory parts | Removing and replacing parts in the model 5/75 |
| Memory module 36 | MEMDIMM | Un-P2-C36 | Yes | Memory parts | Removing and replacing parts in the model 5/75 |
| Memory module 37 | MEMDIMM | Un-P2-C37 | Yes | Memory parts | Removing and replacing parts in the model 5/75 |
| Memory module 38 | MEMDIMM | Un-P2-C38 | Yes | Memory parts | Removing and replacing parts in the model 5/75 |

Service provider information

|                  |         |                                                      |     |                 |                                                |
|------------------|---------|------------------------------------------------------|-----|-----------------|------------------------------------------------|
| Memory module 39 | MEMDIMM | Un-P2-C39                                            | Yes | Memory parts    | Removing and replacing parts in the model 5/75 |
| Memory module 40 | MEMDIMM | Un-P2-C40                                            | Yes | Memory parts    | Removing and replacing parts in the model 5/75 |
| Memory module 41 | MEMDIMM | Un-P2-C41                                            | Yes | Memory parts    | Removing and replacing parts in the model 5/75 |
| Memory module 42 | MEMDIMM | Un-P2-C42                                            | Yes | Memory parts    | Removing and replacing parts in the model 5/75 |
| Memory module 43 | MEMDIMM | Un-P2-C43                                            | Yes | Memory parts    | Removing and replacing parts in the model 5/75 |
| Memory module 44 | MEMDIMM | Un-P2-C44                                            | Yes | Memory parts    | Removing and replacing parts in the model 5/75 |
| Memory module 45 | MEMDIMM | Un-P2-C45                                            | Yes | Memory parts    | Removing and replacing parts in the model 5/75 |
| Memory module 46 | MEMDIMM | Un-P2-C46                                            | Yes | Memory parts    | Removing and replacing parts in the model 5/75 |
| Memory module 47 | MEMDIMM | Un-P2-C47                                            | Yes | Memory parts    | Removing and replacing parts in the model 5/75 |
| Memory module 48 | MEMDIMM | Un-P2-C48                                            | Yes | Memory parts    | Removing and replacing parts in the model 5/75 |
| Memory module 49 | MEMDIMM | Un-P2-C49                                            | Yes | Memory parts    | Removing and replacing parts in the model 5/75 |
| Memory module 50 | MEMDIMM | Un-P2-C50                                            | Yes | Memory parts    | Removing and replacing parts in the model 5/75 |
| Memory module 51 | MEMDIMM | Un-P2-C51                                            | Yes | Memory parts    | Removing and replacing parts in the model 5/75 |
| Memory module 52 | MEMDIMM | Un-P2-C52                                            | Yes | Memory parts    | Removing and replacing parts in the model 5/75 |
| Memory module 53 | MEMDIMM | Un-P2-C53                                            | Yes | Memory parts    | Removing and replacing parts in the model 5/75 |
| Memory module 54 | MEMDIMM | Un-P2-C54                                            | Yes | Memory parts    | Removing and replacing parts in the model 5/75 |
| Memory module 55 | MEMDIMM | Un-P2-C55                                            | Yes | Memory parts    | Removing and replacing parts in the model 5/75 |
| Memory module 56 | MEMDIMM | Un-P2-C56                                            | Yes | Memory parts    | Removing and replacing parts in the model 5/75 |
| Memory module 57 | MEMDIMM | Un-P2-C57                                            | Yes | Memory parts    | Removing and replacing parts in the model 5/75 |
| Memory module 58 | MEMDIMM | Un-P2-C58                                            | Yes | Memory parts    | Removing and replacing parts in the model 5/75 |
| Memory module 59 | MEMDIMM | Un-P2-C59                                            | Yes | Memory parts    | Removing and replacing parts in the model 5/75 |
| Memory module 60 | MEMDIMM | Un-P2-C60                                            | Yes | Memory parts    | Removing and replacing parts in the model 5/75 |
| Memory module 61 | MEMDIMM | Un-P2-C61                                            | Yes | Memory parts    | Removing and replacing parts in the model 5/75 |
| Memory module 62 | MEMDIMM | Un-P2-C62                                            | Yes | Memory parts    | Removing and replacing parts in the model 5/75 |
| Memory module 63 | MEMDIMM | Un-P2-C63                                            | Yes | Memory parts    | Removing and replacing parts in the model 5/75 |
| Memory module 64 | MEMDIMM | Un-P2-C64                                            | Yes | Memory parts    | Removing and replacing parts in the model 5/75 |
| Device locations |         |                                                      |     |                 |                                                |
| Disk drive 1     |         | Un-P1-D1<br>(Un-P1-T9-L8-L0 is the logical location) | Yes | Disk unit parts | Disk drive                                     |

Service provider information

|              |  |                                                                  |     |                 |            |
|--------------|--|------------------------------------------------------------------|-----|-----------------|------------|
|              |  | code)                                                            |     |                 |            |
| Disk drive 2 |  | Un-P1-D2<br>(Un-P1-T10-L8-L0 is<br>the logical location<br>code) | Yes | Disk unit parts | Disk drive |

Parent topic: [Finding part locations](#)

## Locations model ESCALA PL 3250R, PL 3250R+, ESCALA PL 6450 or PL 6450R+

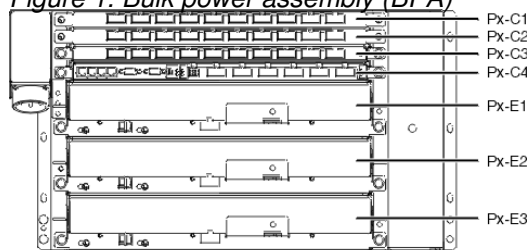
Use this information to help you map a location code to a position on the server for the ESCALA PL 3250R, ESCALA PL 6450R, 9406-595 models, and 5792 racks.

**Note:** The known logical location codes for this unit are listed next to the corresponding physical location in the following information. If you are working with a logical location code for this unit and it is not listed in the following information, contact your next level of support.

The following diagrams show field replaceable unit (FRU) layout in the system unit. Use them with the following tables.

**Note:** Some units may have labels that designate location codes other than those shown in the following illustrations and tables. If that is the case, use the location codes shown in the following illustrations and tables.

Figure 1. Bulk power assembly (BPA)



IPHA1061-1

Figure 2. Bulk power distribution (BPD)

Service provider information

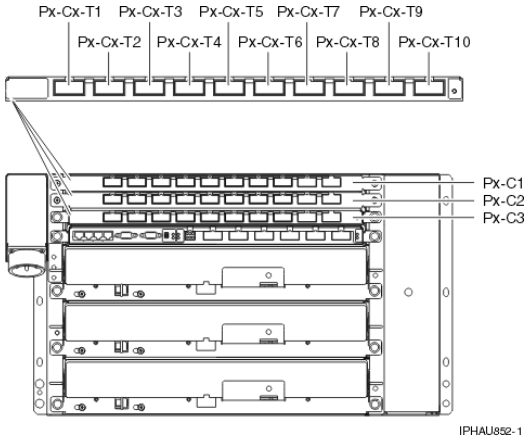


Figure 3. Bulk power controller (BPC)

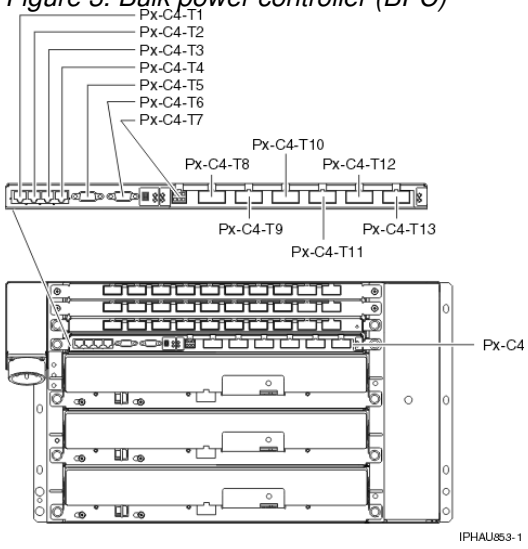


Figure 4. Bulk power regulator (BPR)

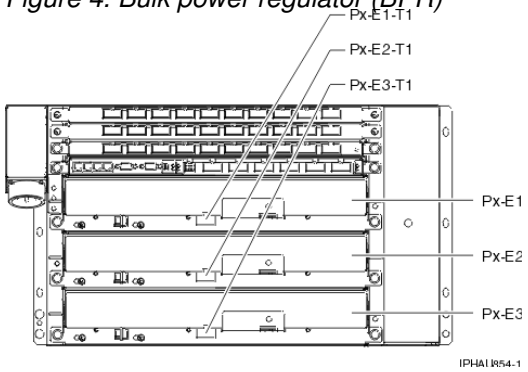




Figure 5. Processor subsystem assembly

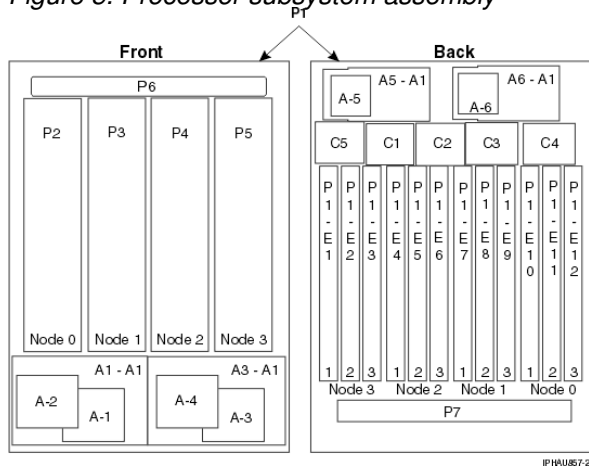


Figure 6. Service processor

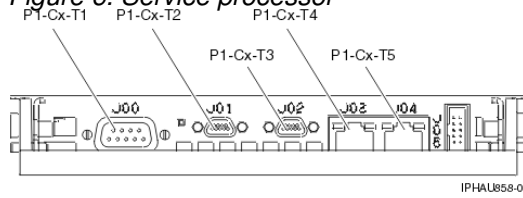


Figure 7. Node assembly

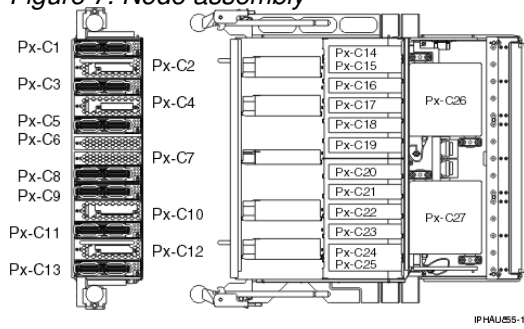


Figure 8. RIO cable connections

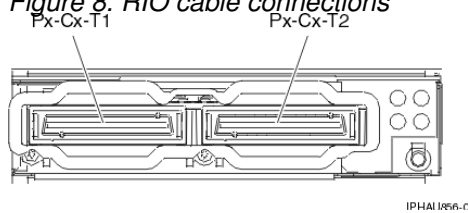
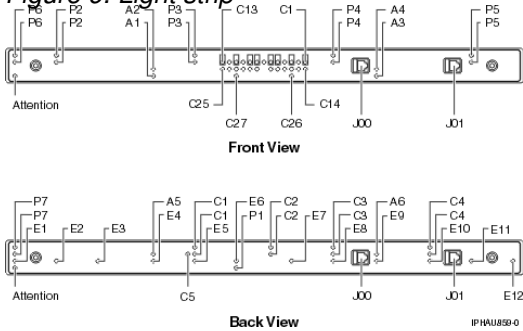


Figure 9. Light strip



Use the following illustrations to help you map a location code to a position on the server. See [Understanding location codes](#) for an explanation of *Un*. See [Model ESCALA PL 3250R, PL 3250R+, ESCALA PL 6450 or PL 6450R+ cables](#) for a listing of cables and plug locations.

**Attention:** After replacing any part on a server or expansion unit, perform [Verifying the repair](#).

Table 1. Bulk power assembly (BPA) FRU locations and failing components

| Failing item name                                                                                                                                                                                                                                                                                                                                                                                                                                                               | Symbolic FRU name | Physical location code                | Link to part number         | Failing item removal and replacement procedures                                                   |
|---------------------------------------------------------------------------------------------------------------------------------------------------------------------------------------------------------------------------------------------------------------------------------------------------------------------------------------------------------------------------------------------------------------------------------------------------------------------------------|-------------------|---------------------------------------|-----------------------------|---------------------------------------------------------------------------------------------------|
| System unit bulk power assembly (BPA)                                                                                                                                                                                                                                                                                                                                                                                                                                           |                   | <i>Un</i>                             |                             |                                                                                                   |
| Bulk power distribution (BPD) Where:                                                                                                                                                                                                                                                                                                                                                                                                                                            |                   |                                       |                             |                                                                                                   |
| <ul style="list-style-type: none"> <li>• Bulk power distribution (BPD) 3A (front) is <i>Un</i>-P1-C1</li> <li>• Bulk power distribution (BPD) 2A (front) is <i>Un</i>-P1-C2</li> <li>• Bulk power distribution (BPD) 1A (front) is <i>Un</i>-P1-C3</li> <li>• Bulk power distribution (BPD) 3B (back) is <i>Un</i>-P2-C1</li> <li>• Bulk power distribution (BPD) 2B (back) is <i>Un</i>-P2-C2</li> <li>• Bulk power distribution (BPD) 1B (back) is <i>Un</i>-P2-C3</li> </ul> |                   |                                       |                             |                                                                                                   |
| Bulk power distribution (BPD) <i>x</i>                                                                                                                                                                                                                                                                                                                                                                                                                                          |                   | <i>Un</i> -P <i>x</i> -C <i>x</i>     | <a href="#">Power parts</a> | Removing and replacing parts in the model ESCALA PL 3250R, PL 3250R+, ESCALA PL 6450 or PL 6450R+ |
| Bulk power distribution (BPD) <i>x</i> connector J00                                                                                                                                                                                                                                                                                                                                                                                                                            |                   | <i>Un</i> -P <i>x</i> -C <i>x</i> -T1 |                             |                                                                                                   |
| Bulk power distribution (BPD) <i>x</i> connector J01                                                                                                                                                                                                                                                                                                                                                                                                                            |                   | <i>Un</i> -P <i>x</i> -C <i>x</i> -T2 |                             |                                                                                                   |
| Bulk power distribution                                                                                                                                                                                                                                                                                                                                                                                                                                                         |                   | <i>Un</i> -P <i>x</i> -C <i>x</i> -T3 |                             |                                                                                                   |

|                                                                                                                                                                   |  |              |             |                                                                                                   |
|-------------------------------------------------------------------------------------------------------------------------------------------------------------------|--|--------------|-------------|---------------------------------------------------------------------------------------------------|
| (BPD) x connector J02                                                                                                                                             |  |              |             |                                                                                                   |
| Bulk power distribution (BPD) x connector J03                                                                                                                     |  | Un-Px-Cx-T4  |             |                                                                                                   |
| Bulk power distribution (BPD) x connector J04                                                                                                                     |  | Un-Px-Cx-T5  |             |                                                                                                   |
| Bulk power distribution (BPD) x connector J05                                                                                                                     |  | Un-Px-Cx-T6  |             |                                                                                                   |
| Bulk power distribution (BPD) x connector J06                                                                                                                     |  | Un-Px-Cx-T7  |             |                                                                                                   |
| Bulk power distribution (BPD) x connector J07                                                                                                                     |  | Un-Px-Cx-T8  |             |                                                                                                   |
| Bulk power distribution (BPD) x connector J08                                                                                                                     |  | Un-Px-Cx-T9  |             |                                                                                                   |
| Bulk power distribution (BPD) x connector J09                                                                                                                     |  | Un-Px-Cx-T10 |             |                                                                                                   |
| Bulk power controller (BPC) Where:                                                                                                                                |  |              |             |                                                                                                   |
| <ul style="list-style-type: none"> <li>• Bulk power controller (BPC) A (front) is Un-P1-C4</li> <li>• Bulk power controller (BPC) B (back) is Un-P2-C4</li> </ul> |  |              |             |                                                                                                   |
| Bulk power controller (BPC) x                                                                                                                                     |  | Un-Px-C4     | Power parts | Removing and replacing parts in the model ESCALA PL 3250R, PL 3250R+, ESCALA PL 6450 or PL 6450R+ |
| Bulk power controller (BPC) x connector J00A                                                                                                                      |  | Un-Px-C4-T1  |             | Removing and replacing parts in the model ESCALA PL 3250R, PL 3250R+, ESCALA PL 6450 or PL 6450R+ |
| Bulk power controller (BPC) x connector J00B                                                                                                                      |  | Un-Px-C4-T2  |             |                                                                                                   |
| Bulk power controller (BPC) x connector J00C                                                                                                                      |  | Un-Px-C4-T3  |             |                                                                                                   |
| Bulk power controller (BPC) x connector J00D                                                                                                                      |  | Un-Px-C4-T4  |             |                                                                                                   |
| Bulk power controller (BPC) x connector J01                                                                                                                       |  | Un-Px-C4-T5  |             |                                                                                                   |
| Bulk power controller (BPC)                                                                                                                                       |  | Un-Px-C4-T6  |             |                                                                                                   |

## Service provider information

|                                                |  |              |             |                                                                                                   |
|------------------------------------------------|--|--------------|-------------|---------------------------------------------------------------------------------------------------|
| x connector J02                                |  |              |             |                                                                                                   |
| Bulk power controller (BPC)<br>x connector J03 |  | Un-Px-C4-T7  |             |                                                                                                   |
| Bulk power controller (BPC)<br>x connector J04 |  | Un-Px-C4-T8  |             |                                                                                                   |
| Bulk power controller (BPC)<br>x connector J05 |  | Un-Px-C4-T9  |             |                                                                                                   |
| Bulk power controller (BPC)<br>x connector J06 |  | Un-Px-C4-T10 |             |                                                                                                   |
| Bulk power controller (BPC)<br>x connector J07 |  | Un-Px-C4-T11 |             |                                                                                                   |
| Bulk power controller (BPC)<br>x connector J08 |  | Un-Px-C4-T12 |             |                                                                                                   |
| Bulk power controller (BPC)<br>x connector J09 |  | Un-Px-C4-T13 |             |                                                                                                   |
| Bulk power regulator (BPR)                     |  |              |             |                                                                                                   |
| Bulk power regulator (BPR)<br>3A (front)       |  | Un-P1-E3     | Power parts | Removing and replacing parts in the model ESCALA PL 3250R, PL 3250R+, ESCALA PL 6450 or PL 6450R+ |
| Bulk power regulator (BPR)<br>3A connector J00 |  | Un-P1-E3-T1  |             |                                                                                                   |
| Bulk power regulator (BPR)<br>2A (front)       |  | Un-P1-E2     | Power parts | Removing and replacing parts in the model ESCALA PL 3250R, PL 3250R+, ESCALA PL 6450 or PL 6450R+ |
| Bulk power regulator (BPR)<br>2A connector J00 |  | Un-P1-E2-T1  |             |                                                                                                   |
| Bulk power regulator (BPR)<br>1A (front)       |  | Un-P1-E1     | Power parts | Removing and replacing parts in the model ESCALA PL 3250R, PL 3250R+, ESCALA PL 6450 or PL 6450R+ |
| Bulk power regulator (BPR)<br>1A connector J00 |  | Un-P1-E1-T1  |             |                                                                                                   |
| Bulk power regulator (BPR)<br>3B (back)        |  | Un-P2-E3     | Power parts | Removing and replacing parts in the model ESCALA PL 3250R, PL 3250R+, ESCALA PL 6450 or PL 6450R+ |
| Bulk power regulator (BPR)<br>3B connector J00 |  | Un-P2-E3-T1  |             |                                                                                                   |
|                                                |  | Un-P2-E2     | Power parts |                                                                                                   |

## Service provider information

|                                             |  |             |             |                                                                                                   |
|---------------------------------------------|--|-------------|-------------|---------------------------------------------------------------------------------------------------|
| Bulk power regulator (BPR) 2B (back)        |  |             |             | Removing and replacing parts in the model ESCALA PL 3250R, PL 3250R+, ESCALA PL 6450 or PL 6450R+ |
| Bulk power regulator (BPR) 2B connector J00 |  | Un-P2-E2-T1 |             |                                                                                                   |
| Bulk power regulator (BPR) 1B (back)        |  | Un-P2-E1    | Power parts | Removing and replacing parts in the model ESCALA PL 3250R, PL 3250R+, ESCALA PL 6450 or PL 6450R+ |
| Bulk power regulator (BPR) 1B connector J00 |  | Un-P2-E1-T1 |             |                                                                                                   |
| Fans                                        |  |             |             |                                                                                                   |
| Bulk power fan (BPF) A (front)              |  | Un-A1       | Power parts | Removing and replacing parts in the model ESCALA PL 3250R, PL 3250R+, ESCALA PL 6450 or PL 6450R+ |
| Bulk power fan (BPF) B (back)               |  | Un-A2       | Power parts | Removing and replacing parts in the model ESCALA PL 3250R, PL 3250R+, ESCALA PL 6450 or PL 6450R+ |
| Emergency power off (EPO)                   |  |             |             |                                                                                                   |
| Emergency power off (EPO)                   |  | Un-D1       | Power parts | Removing and replacing parts in the model ESCALA PL 3250R, PL 3250R+, ESCALA PL 6450 or PL 6450R+ |
| Emergency power off (EPO) connector J00     |  | Un-D1-T1    |             |                                                                                                   |
| Emergency power off (EPO) J01               |  | Un-D1-T2    |             |                                                                                                   |

Table 2. Processor subsystem assembly FRU locations and failing components

| Failing item name                             | Symbolic FRU name | Physical location code | Identify LED       | Link to part number    | Failing item removal and replacement procedures                                                   |
|-----------------------------------------------|-------------------|------------------------|--------------------|------------------------|---------------------------------------------------------------------------------------------------|
| System unit processor subsystem assembly      |                   | Un                     |                    |                        |                                                                                                   |
| Fans                                          |                   |                        |                    |                        |                                                                                                   |
| Motor drive assembly 1 (closest to the front) |                   | Un-A1                  | Light strip, front | Part assembly diagrams | Removing and replacing parts in the model ESCALA PL 3250R, PL 3250R+, ESCALA PL 6450 or PL 6450R+ |
| Motor drive assembly 1                        |                   | Un-A1-T1               |                    |                        |                                                                                                   |

Service provider information

|                                                  |  |          |                    |                        |                                                                                                   |
|--------------------------------------------------|--|----------|--------------------|------------------------|---------------------------------------------------------------------------------------------------|
| J00                                              |  |          |                    |                        |                                                                                                   |
| Motor drive assembly 1<br>J01                    |  | Un-A1-T2 |                    |                        |                                                                                                   |
| Motor scroll assembly 1                          |  | Un-A1-A1 |                    | Part assembly diagrams | Removing and replacing parts in the model ESCALA PL 3250R, PL 3250R+, ESCALA PL 6450 or PL 6450R+ |
| Motor drive assembly 2                           |  | Un-A2    | Light strip, front | Part assembly diagrams | Removing and replacing parts in the model ESCALA PL 3250R, PL 3250R+, ESCALA PL 6450 or PL 6450R+ |
| Motor drive assembly 2<br>J00                    |  | Un-A2-T1 |                    |                        |                                                                                                   |
| Motor drive assembly 2<br>J01                    |  | Un-A2-T2 |                    |                        |                                                                                                   |
| Motor drive assembly 3<br>(closest to the front) |  | Un-A3    | Light strip, front | Part assembly diagrams | Removing and replacing parts in the model ESCALA PL 3250R, PL 3250R+, ESCALA PL 6450 or PL 6450R+ |
| Motor drive assembly 3<br>J00                    |  | Un-A3-T1 |                    |                        |                                                                                                   |
| Motor drive assembly 3<br>J01                    |  | Un-A3-T2 |                    |                        |                                                                                                   |
| Motor scroll assembly 2                          |  | Un-A3-A1 |                    | Part assembly diagrams | Removing and replacing parts in the model ESCALA PL 3250R, PL 3250R+, ESCALA PL 6450 or PL 6450R+ |
| Motor drive assembly 4                           |  | Un-A4    | Light strip, front | Part assembly diagrams | Removing and replacing parts in the model ESCALA PL 3250R, PL 3250R+, ESCALA PL 6450 or PL 6450R+ |
| Motor drive assembly 4<br>J00                    |  | Un-A4-T1 |                    |                        |                                                                                                   |
| Motor drive assembly 4<br>J01                    |  | Un-A4-T2 |                    |                        |                                                                                                   |
| Motor drive assembly 5                           |  | Un-A5    | Light strip, back  | Part assembly diagrams | Removing and replacing parts in the model ESCALA PL 3250R, PL 3250R+, ESCALA PL 6450 or PL 6450R+ |
| Motor drive assembly 5<br>J00                    |  | Un-A5-T1 |                    |                        |                                                                                                   |

Service provider information

|                                                                 |        |          |                    |                        |                                                                                                   |
|-----------------------------------------------------------------|--------|----------|--------------------|------------------------|---------------------------------------------------------------------------------------------------|
| Motor drive assembly 5 J01                                      |        | Un-A5-T2 |                    |                        |                                                                                                   |
| Motor scroll assembly 3                                         |        | Un-A5-A1 |                    | Part assembly diagrams | Removing and replacing parts in the model ESCALA PL 3250R, PL 3250R+, ESCALA PL 6450 or PL 6450R+ |
| Motor drive assembly 6                                          |        | Un-A6    | Light strip, back  | Part assembly diagrams | Removing and replacing parts in the model ESCALA PL 3250R, PL 3250R+, ESCALA PL 6450 or PL 6450R+ |
| Motor drive assembly 6 J00                                      |        | Un-A6-T1 |                    |                        |                                                                                                   |
| Motor drive assembly 6 J01                                      |        | Un-A6-T2 |                    |                        |                                                                                                   |
| Motor scroll assembly 4                                         |        | Un-A6-A1 |                    | Part assembly diagrams | Removing and replacing parts in the model ESCALA PL 3250R, PL 3250R+, ESCALA PL 6450 or PL 6450R+ |
| Backplanes                                                      |        |          |                    |                        |                                                                                                   |
| System backplane<br><br>• SPCN<br>• Card enclosure or backplane |        | Un-P1    | Light strip, back  | System parts           | Removing and replacing parts in the model ESCALA PL 3250R, PL 3250R+, ESCALA PL 6450 or PL 6450R+ |
| Node 0 backplane                                                | NODEPL | Un-P2    | Light strip, front | System parts           | Removing and replacing parts in the model ESCALA PL 3250R, PL 3250R+, ESCALA PL 6450 or PL 6450R+ |
| Node 1 backplane                                                | NODEPL | Un-P3    | Light strip, front | System parts           | Removing and replacing parts in the model ESCALA PL 3250R, PL 3250R+, ESCALA PL 6450 or PL 6450R+ |
| Node 2 backplane                                                | NODEPL | Un-P4    | Light strip, front | System parts           | Removing and replacing parts in the model ESCALA PL 3250R, PL 3250R+, ESCALA PL 6450 or PL 6450R+ |
| Node 3 backplane                                                | NODEPL | Un-P5    | Light strip, front | System parts           | Removing and replacing parts in the model ESCALA PL 3250R, PL 3250R+, ESCALA PL 6450 or PL 6450R+ |
| Service processors                                              |        |          |                    |                        |                                                                                                   |

Service provider information

|                                                                                                                                                                                                               |  |             |                    |                        |                                                                                                   |
|---------------------------------------------------------------------------------------------------------------------------------------------------------------------------------------------------------------|--|-------------|--------------------|------------------------|---------------------------------------------------------------------------------------------------|
| Service processor 0                                                                                                                                                                                           |  | Un-P1-C4    | Light strip, back  | System parts           | Removing and replacing parts in the model ESCALA PL 3250R, PL 3250R+, ESCALA PL 6450 or PL 6450R+ |
| SPCN connector                                                                                                                                                                                                |  | Un-P1-C4-T1 |                    |                        |                                                                                                   |
| Light strip connector (front)                                                                                                                                                                                 |  | Un-P1-C4-T2 |                    |                        |                                                                                                   |
| Light strip connector (back)                                                                                                                                                                                  |  | Un-P1-C4-T3 |                    |                        |                                                                                                   |
| HMC port 0 connector                                                                                                                                                                                          |  | Un-P1-C4-T4 | Yes                |                        |                                                                                                   |
| HMC port 1 connector                                                                                                                                                                                          |  | Un-P1-C4-T5 | Yes                |                        |                                                                                                   |
| Service processor 1                                                                                                                                                                                           |  | Un-P1-C1    | Light strip, back  | System parts           | Removing and replacing parts in the model ESCALA PL 3250R, PL 3250R+, ESCALA PL 6450 or PL 6450R+ |
| SPCN connector                                                                                                                                                                                                |  | Un-P1-C1-T1 |                    |                        |                                                                                                   |
| Light strip connector (front)                                                                                                                                                                                 |  | Un-P1-C1-T2 |                    |                        |                                                                                                   |
| Light strip connector (back)                                                                                                                                                                                  |  | Un-P1-C1-T3 |                    |                        |                                                                                                   |
| HMC port 0 connector                                                                                                                                                                                          |  | Un-P1-C1-T4 | Yes                |                        |                                                                                                   |
| HMC port 1 connector                                                                                                                                                                                          |  | Un-P1-C1-T5 | Yes                |                        |                                                                                                   |
| <p>Processor and processor regulator Where Px is defined as:</p> <ul style="list-style-type: none"> <li>• P2 is node 0</li> <li>• P3 is node 1</li> <li>• P4 is node 2</li> <li>• Power5 is node 3</li> </ul> |  |             |                    |                        |                                                                                                   |
| MCM 0 for node <i>n</i>                                                                                                                                                                                       |  | Un-Px-C26   | Light strip, front | System parts           | Removing and replacing parts in the model ESCALA PL 3250R, PL 3250R+, ESCALA PL 6450 or PL 6450R+ |
| MCM 1 for node <i>n</i>                                                                                                                                                                                       |  | Un-Px-C27   | Light strip, front | System parts           | Removing and replacing parts in the model ESCALA PL 3250R, PL 3250R+, ESCALA PL 6450 or PL 6450R+ |
| Distributed converter assembly (DCA) 31 for node 3                                                                                                                                                            |  | Un-P1-E1    | Light strip, back  | Part assembly diagrams | Removing and replacing parts in the model ESCALA PL 3250R, PL 3250R+, ESCALA PL 6450 or PL 6450R+ |



Service provider information

|                                                    |  |             |                   |                        |                                                                                                   |
|----------------------------------------------------|--|-------------|-------------------|------------------------|---------------------------------------------------------------------------------------------------|
| Distributed converter assembly (DCA) 31 J00        |  | Un-P1-E1-T1 |                   |                        |                                                                                                   |
| Distributed converter assembly (DCA) 31 J01        |  | Un-P1-E1-T2 |                   |                        |                                                                                                   |
| Distributed converter assembly (DCA) 32 for node 3 |  | Un-P1-E2    | Light strip, back | Part assembly diagrams | Removing and replacing parts in the model ESCALA PL 3250R, PL 3250R+, ESCALA PL 6450 or PL 6450R+ |
| Distributed converter assembly (DCA) 32 J00        |  | Un-P1-E2-T1 |                   |                        |                                                                                                   |
| Distributed converter assembly (DCA) 32 J01        |  | Un-P1-E2-T2 |                   |                        |                                                                                                   |
| Distributed converter assembly (DCA) 33 for node 3 |  | Un-P1-E3    | Light strip, back | Part assembly diagrams | Removing and replacing parts in the model ESCALA PL 3250R, PL 3250R+, ESCALA PL 6450 or PL 6450R+ |
| Distributed converter assembly (DCA) 33 J00        |  | Un-P1-E3-T1 |                   |                        |                                                                                                   |
| Distributed converter assembly (DCA) 33 J01        |  | Un-P1-E3-T2 |                   |                        |                                                                                                   |
| Distributed converter assembly (DCA) 21 for node 2 |  | Un-P1-E4    | Light strip, back | Part assembly diagrams | Removing and replacing parts in the model ESCALA PL 3250R, PL 3250R+, ESCALA PL 6450 or PL 6450R+ |
| Distributed converter assembly (DCA) 21 J00        |  | Un-P1-E4-T1 |                   |                        |                                                                                                   |
| Distributed converter assembly (DCA) 21 J01        |  | Un-P1-E4-T2 |                   |                        |                                                                                                   |
| Distributed converter assembly (DCA) 22 for node 2 |  | Un-P1-E5    | Light strip, back | Part assembly diagrams | Removing and replacing parts in the model ESCALA PL 3250R, PL 3250R+, ESCALA PL 6450 or PL 6450R+ |
| Distributed converter assembly (DCA) 22 J00        |  | Un-P1-E5-T1 |                   |                        |                                                                                                   |
| Distributed                                        |  | Un-P1-E5-T2 |                   |                        |                                                                                                   |

Service provider information

|                                                    |  |             |                   |                        |                                                                                                   |
|----------------------------------------------------|--|-------------|-------------------|------------------------|---------------------------------------------------------------------------------------------------|
| converter assembly (DCA) 22 J01                    |  |             |                   |                        |                                                                                                   |
| Distributed converter assembly (DCA) 23 for node 2 |  | Un-P1-E6    | Light strip, back | Part assembly diagrams | Removing and replacing parts in the model ESCALA PL 3250R, PL 3250R+, ESCALA PL 6450 or PL 6450R+ |
| Distributed converter assembly (DCA) 23 J00        |  | Un-P1-E6-T1 |                   |                        |                                                                                                   |
| Distributed converter assembly (DCA) 23 J01        |  | Un-P1-E6-T2 |                   |                        |                                                                                                   |
| Distributed converter assembly (DCA) 11 for node 1 |  | Un-P1-E7    | Light strip, back | Part assembly diagrams | Removing and replacing parts in the model ESCALA PL 3250R, PL 3250R+, ESCALA PL 6450 or PL 6450R+ |
| Distributed converter assembly (DCA) 11 J00        |  | Un-P1-E7-T1 |                   |                        |                                                                                                   |
| Distributed converter assembly (DCA) 11 J01        |  | Un-P1-E7-T2 |                   |                        |                                                                                                   |
| Distributed converter assembly (DCA) 12 for node 1 |  | Un-P1-E8    | Light strip, back | Part assembly diagrams | Removing and replacing parts in the model ESCALA PL 3250R, PL 3250R+, ESCALA PL 6450 or PL 6450R+ |
| Distributed converter assembly (DCA) 12 J00        |  | Un-P1-E8-T1 |                   |                        |                                                                                                   |
| Distributed converter assembly (DCA) 12 J01        |  | Un-P1-E8-T2 |                   |                        |                                                                                                   |
| Distributed converter assembly (DCA) 13 for node 1 |  | Un-P1-E9    | Light strip, back | Part assembly diagrams | Removing and replacing parts in the model ESCALA PL 3250R, PL 3250R+, ESCALA PL 6450 or PL 6450R+ |
| Distributed converter assembly (DCA) 13 J00        |  | Un-P1-E9-T1 |                   |                        |                                                                                                   |
| Distributed converter assembly (DCA) 13 J01        |  | Un-P1-E9-T2 |                   |                        |                                                                                                   |
| Distributed converter                              |  | Un-P1-E10   | Light strip, back | Part assembly diagrams | Removing and replacing parts in the                                                               |

Service provider information

|                                                    |  |              |                   |                        |                                                                                                   |
|----------------------------------------------------|--|--------------|-------------------|------------------------|---------------------------------------------------------------------------------------------------|
| assembly (DCA) 01 for node 0                       |  |              |                   |                        | model ESCALA PL 3250R, PL 3250R+, ESCALA PL 6450 or PL 6450R+                                     |
| Distributed converter assembly (DCA) 01 J00        |  | Un-P1-E10-T1 |                   |                        |                                                                                                   |
| Distributed converter assembly (DCA) 01 J01        |  | Un-P1-E10-T2 |                   |                        |                                                                                                   |
| Distributed converter assembly (DCA) 02 for node 0 |  | Un-P1-E11    | Light strip, back | Part assembly diagrams | Removing and replacing parts in the model ESCALA PL 3250R, PL 3250R+, ESCALA PL 6450 or PL 6450R+ |
| Distributed converter assembly (DCA) 02 J00        |  | Un-P1-E11-T1 |                   |                        |                                                                                                   |
| Distributed converter assembly (DCA) 02 J01        |  | Un-P1-E11-T2 |                   |                        |                                                                                                   |
| Distributed converter assembly (DCA) 03 for node 0 |  | Un-P1-E12    | Light strip, back | Part assembly diagrams | Removing and replacing parts in the model ESCALA PL 3250R, PL 3250R+, ESCALA PL 6450 or PL 6450R+ |
| Distributed converter assembly (DCA) 03 J00        |  | Un-P1-E12-T1 |                   |                        |                                                                                                   |
| Distributed converter assembly (DCA) 03 J01        |  | Un-P1-E12-T2 |                   |                        |                                                                                                   |
| Light strip, front                                 |  | Un-P6        | Yes               | 291A                   | Removing and replacing parts in the model ESCALA PL 3250R, PL 3250R+, ESCALA PL 6450 or PL 6450R+ |
| Light strip, back                                  |  | Un-P7        | Yes               | 291B                   | Removing and replacing parts in the model ESCALA PL 3250R, PL 3250R+, ESCALA PL 6450 or PL 6450R+ |
| Oscillator 0                                       |  | Un-P1-C3     | Light strip, back | 28E4                   | Removing and replacing parts in the model ESCALA PL 3250R, PL 3250R+, ESCALA PL 6450 or PL 6450R+ |
| Oscillator 1                                       |  | Un-P1-C2     | Light strip, back | 28E4                   | Removing and replacing parts in the model ESCALA PL 3250R, PL 3250R+,                             |

Service provider information

|                                                                                                                                              |                                     |          |                    |              |                                                                                                   |
|----------------------------------------------------------------------------------------------------------------------------------------------|-------------------------------------|----------|--------------------|--------------|---------------------------------------------------------------------------------------------------|
|                                                                                                                                              |                                     |          |                    |              | ESCALA PL 6450 or PL 6450R+                                                                       |
| Service processor 0                                                                                                                          |                                     | Un-P1-C4 | Light strip, back  | 28DE         | Removing and replacing parts in the model ESCALA PL 3250R, PL 3250R+, ESCALA PL 6450 or PL 6450R+ |
| Service processor 1                                                                                                                          |                                     | Un-P1-C1 | Light strip, back  | 28DE         | Removing and replacing parts in the model ESCALA PL 3250R, PL 3250R+, ESCALA PL 6450 or PL 6450R+ |
| VPD card                                                                                                                                     |                                     | Un-P1-C5 | Light strip, back  | System parts | Removing and replacing parts in the model ESCALA PL 3250R, PL 3250R+, ESCALA PL 6450 or PL 6450R+ |
| Adapters Where Px is defined as:                                                                                                             |                                     |          |                    |              |                                                                                                   |
| <ul style="list-style-type: none"> <li>• P2 is node 0</li> <li>• P3 is node 1</li> <li>• P4 is node 2</li> <li>• Power5 is node 3</li> </ul> |                                     |          |                    |              |                                                                                                   |
| Adapter 1 for node x                                                                                                                         | SI_CARD<br>SICNTRL<br>IO_HUB<br>HCA | Un-Px-C1 | Light strip, front | System parts | Removing and replacing parts in the model ESCALA PL 3250R, PL 3250R+, ESCALA PL 6450 or PL 6450R+ |
| Adapter 2 for node x                                                                                                                         | SI_CARD<br>SICNTRL<br>IO_HUB<br>HCA | Un-Px-C3 | Light strip, front | System parts | Removing and replacing parts in the model ESCALA PL 3250R, PL 3250R+, ESCALA PL 6450 or PL 6450R+ |
| Adapter 3 for node x                                                                                                                         | SI_CARD<br>SICNTRL<br>IO_HUB<br>HCA | Un-Px-C5 | Light strip, front | System parts | Removing and replacing parts in the model ESCALA PL 3250R, PL 3250R+, ESCALA PL 6450 or PL 6450R+ |
| <b>Note:</b> This card cannot have any RIO cables attached.                                                                                  |                                     |          |                    |              |                                                                                                   |
| Adapter 4 for node x                                                                                                                         | SI_CARD<br>SICNTRL<br>IO_HUB<br>HCA | Un-Px-C6 | Light strip, front | System parts | Removing and replacing parts in the model ESCALA PL 3250R, PL 3250R+, ESCALA PL 6450 or PL 6450R+ |
| Adapter 5 for node x                                                                                                                         | SI_CARD<br>SICNTRL<br>IO_HUB<br>HCA | Un-Px-C8 | Light strip, front | System parts | Removing and replacing parts in the model ESCALA PL 3250R, PL 3250R+, ESCALA PL 6450 or PL 6450R+ |
|                                                                                                                                              |                                     | Un-Px-C9 |                    | System parts |                                                                                                   |

Service provider information

|                                                                                                                                                                                                                                                                                                                                                                                                                                                                                                 |                                     |              |                    |              |                                                                                                   |
|-------------------------------------------------------------------------------------------------------------------------------------------------------------------------------------------------------------------------------------------------------------------------------------------------------------------------------------------------------------------------------------------------------------------------------------------------------------------------------------------------|-------------------------------------|--------------|--------------------|--------------|---------------------------------------------------------------------------------------------------|
| Adapter6 for node x                                                                                                                                                                                                                                                                                                                                                                                                                                                                             | SI_CARD<br>SICNTRL<br>IO_HUB<br>HCA |              | Light strip, front |              | Removing and replacing parts in the model ESCALA PL 3250R, PL 3250R+, ESCALA PL 6450 or PL 6450R+ |
| Adapter 7 for node x                                                                                                                                                                                                                                                                                                                                                                                                                                                                            | SI_CARD<br>SICNTRL<br>IO_HUB<br>HCA | Un-Px-C11    | Light strip, front | System parts | Removing and replacing parts in the model ESCALA PL 3250R, PL 3250R+, ESCALA PL 6450 or PL 6450R+ |
| Adapter 8 for node x                                                                                                                                                                                                                                                                                                                                                                                                                                                                            | SI_CARD<br>SICNTRL<br>IO_HUB<br>HCA | Un-Px-C13    | Light strip, front | System parts | Removing and replacing parts in the model ESCALA PL 3250R, PL 3250R+, ESCALA PL 6450 or PL 6450R+ |
| Multiplexer card for node x                                                                                                                                                                                                                                                                                                                                                                                                                                                                     |                                     | Un-Px-C7     | Light strip, front | 28E6         | Removing and replacing parts in the model ESCALA PL 3250R, PL 3250R+, ESCALA PL 6450 or PL 6450R+ |
| <p>Adapter ports Where Px is defined as:</p> <ul style="list-style-type: none"> <li>• P2 is node 0</li> <li>• P3 is node 1</li> <li>• P4 is node 2</li> <li>• Power5 is node 3</li> </ul> <p>And where Cx is defined as:</p> <ul style="list-style-type: none"> <li>• C1 is adapter 1</li> <li>• C3 is adapter 2</li> <li>• C5 is adapter 3</li> <li>• C6 is adapter 4</li> <li>• C8 is adapter 5</li> <li>• C9 is adapter 6</li> <li>• C11 is adapter 7</li> <li>• C13 is adapter 8</li> </ul> |                                     |              |                    |              |                                                                                                   |
| RIO connector J00                                                                                                                                                                                                                                                                                                                                                                                                                                                                               |                                     | Un-Px-Cx -T1 | Yes                |              |                                                                                                   |
| RIO connector J01                                                                                                                                                                                                                                                                                                                                                                                                                                                                               |                                     | Un-Px-Cx -T2 | Yes                |              |                                                                                                   |
| <p>Memory parts Where Px is defined as:</p> <ul style="list-style-type: none"> <li>• P2 is node 0</li> <li>• P3 is node 1</li> <li>• P4 is node 2</li> <li>• Power5 is node 3</li> </ul>                                                                                                                                                                                                                                                                                                        |                                     |              |                    |              |                                                                                                   |
| Memory card 1 for node x                                                                                                                                                                                                                                                                                                                                                                                                                                                                        | MEMDIMM                             | Un-Px-C2     | Light strip, front | Memory parts | Removing and replacing parts in the model ESCALA PL 3250R, PL 3250R+, ESCALA PL 6450 or PL 6450R+ |
| Memory card 2 for node x                                                                                                                                                                                                                                                                                                                                                                                                                                                                        | MEMDIMM                             | Un-Px-C4     | Light strip, front | Memory parts | Removing and replacing parts in the model ESCALA PL 3250R, PL 3250R+, ESCALA PL 6450 or PL 6450R+ |

## Service provider information

|                                  |         |                  |                    |              |                                                                                                   |
|----------------------------------|---------|------------------|--------------------|--------------|---------------------------------------------------------------------------------------------------|
| Memory card 3 for node <i>x</i>  | MEMDIMM | <i>Un-Px-C10</i> | Light strip, front | Memory parts | Removing and replacing parts in the model ESCALA PL 3250R, PL 3250R+, ESCALA PL 6450 or PL 6450R+ |
| Memory card 4 for node <i>x</i>  | MEMDIMM | <i>Un-Px-C12</i> | Light strip, front | Memory parts | Removing and replacing parts in the model ESCALA PL 3250R, PL 3250R+, ESCALA PL 6450 or PL 6450R+ |
| Memory card 5 for node <i>x</i>  | MEMDIMM | <i>Un-Px-C14</i> | Light strip, front | Memory parts | Removing and replacing parts in the model ESCALA PL 3250R, PL 3250R+, ESCALA PL 6450 or PL 6450R+ |
| Memory card 6 for node <i>x</i>  | MEMDIMM | <i>Un-Px-C15</i> | Light strip, front | Memory parts | Removing and replacing parts in the model ESCALA PL 3250R, PL 3250R+, ESCALA PL 6450 or PL 6450R+ |
| Memory card 7 for node <i>x</i>  | MEMDIMM | <i>Un-Px-C16</i> | Light strip, front | Memory parts | Removing and replacing parts in the model ESCALA PL 3250R, PL 3250R+, ESCALA PL 6450 or PL 6450R+ |
| Memory card 8 for node <i>x</i>  | MEMDIMM | <i>Un-Px-C17</i> | Light strip, front | Memory parts | Removing and replacing parts in the model ESCALA PL 3250R, PL 3250R+, ESCALA PL 6450 or PL 6450R+ |
| Memory card 9 for node <i>x</i>  | MEMDIMM | <i>Un-Px-C18</i> | Light strip, front | Memory parts | Removing and replacing parts in the model ESCALA PL 3250R, PL 3250R+, ESCALA PL 6450 or PL 6450R+ |
| Memory card 10 for node <i>x</i> | MEMDIMM | <i>Un-Px-C19</i> | Light strip, front | Memory parts | Removing and replacing parts in the model ESCALA PL 3250R, PL 3250R+, ESCALA PL 6450 or PL 6450R+ |
| Memory card 11 for node <i>x</i> | MEMDIMM | <i>Un-Px-C20</i> | Light strip, front | Memory parts | Removing and replacing parts in the model ESCALA PL 3250R, PL 3250R+, ESCALA PL 6450 or PL 6450R+ |
| Memory card 12 for node <i>x</i> | MEMDIMM | <i>Un-Px-C21</i> | Light strip, front | Memory parts | Removing and replacing parts in the model ESCALA PL 3250R, PL 3250R+, ESCALA PL 6450 or PL 6450R+ |
| Memory card 13 for node <i>x</i> | MEMDIMM | <i>Un-Px-C22</i> | Light strip, front | Memory parts | Removing and replacing parts in the model ESCALA PL                                               |

|                           |         |           |                    |              |                                                                                                   |
|---------------------------|---------|-----------|--------------------|--------------|---------------------------------------------------------------------------------------------------|
|                           |         |           |                    |              | 3250R, PL 3250R+, ESCALA PL 6450 or PL 6450R+                                                     |
| Memory card 14 for node x | MEMDIMM | Un-Px-C23 | Light strip, front | Memory parts | Removing and replacing parts in the model ESCALA PL 3250R, PL 3250R+, ESCALA PL 6450 or PL 6450R+ |
| Memory card 15 for node x | MEMDIMM | Un-Px-C24 | Light strip, front | Memory parts | Removing and replacing parts in the model ESCALA PL 3250R, PL 3250R+, ESCALA PL 6450 or PL 6450R+ |
| Memory card 16 for node x | MEMDIMM | Un-Px-C25 | Light strip, front | Memory parts | Removing and replacing parts in the model ESCALA PL 3250R, PL 3250R+, ESCALA PL 6450 or PL 6450R+ |

Parent topic: [Finding part locations](#)

## Part assembly diagrams for ESCALA PL 3250R, PL 3250R+, ESCALA PL 6450 or PL 6450R+ and 5792 racks

This content covers the ESCALA PL 3250R, ESCALA PL 6450R, 9406-595 models, and 5792 racks.

### Final assembly

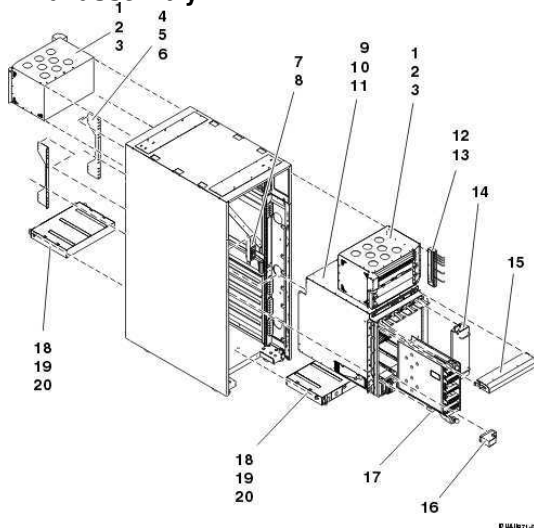


Table 1. Final assembly part numbers

| Index number | Part number | Units per assembly | Description |
|--------------|-------------|--------------------|-------------|
|--------------|-------------|--------------------|-------------|

Service provider information

|    |         |    |                                                                                                             |
|----|---------|----|-------------------------------------------------------------------------------------------------------------|
| 1  | 12R9749 | AR | Bulk power assembly (BPA) For a detailed listing see the <a href="#">Bulk power assembly (BPA)</a> .        |
| 2  | 77G0599 | 2  | Screw, BPE mounting                                                                                         |
| 3  | 74F1823 | 5  | Nut clip                                                                                                    |
| 4  |         | 2  | Bracket, processor subsystem assembly rear                                                                  |
| 5  | 77G0599 | 8  | Screw, processor subsystem assembly rear bracket mounting                                                   |
| 6  | 74F1823 | 8  | Nut clip                                                                                                    |
| 7  | 15R6747 | 1  | Unit emergency power off (UEPO) switch assembly                                                             |
| 8  | 2665528 | 2  | Screw, UEPO mounting                                                                                        |
| 9  |         | AR | Processor subsystem assembly. For a detailed listing see the <a href="#">Processor subsystem assembly</a> . |
| 10 | 77G0599 | AR | Screw, processor subsystem assembly mounting                                                                |
| 11 | 74F1823 | AR | Nut clip                                                                                                    |
| 12 | 11P3843 | 1  | Cable bracket                                                                                               |
| 13 | 77G0599 | 3  | Screw, cable bracket                                                                                        |
| 14 | 44P3384 | AR | Filler, node                                                                                                |
| 15 | 12R6625 | 1  | Cover, EMC                                                                                                  |
| 16 | 12R6626 | 4  | Cover, EMC                                                                                                  |
| 17 |         | AR | Node assembly. For a detailed listing see the <a href="#">Node assembly</a> .                               |
| 18 | 41U0012 | AR | Internal battery feature (IBF)                                                                              |
| 19 | 77G0599 | 2  | Screw                                                                                                       |
| 20 | 5589089 | 2  | Washer                                                                                                      |
|    | 74F1823 | 2  | Nut clip                                                                                                    |
|    | 41V1820 | AR | Rack tie down kit (raised floor short)                                                                      |
|    | 41V1820 | AR | Rack tie down kit (raised floor long)                                                                       |
|    | 41V1820 | AR | Rack tie down kit (non-raised floor)                                                                        |

**Bulk power assembly (BPA)**

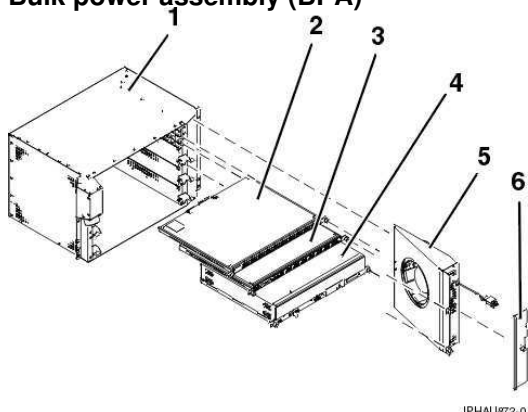


Table 2. Bulk power assembly (BPA) part numbers

| Index number | Part number | Units per assembly | Description |
|--------------|-------------|--------------------|-------------|
|--------------|-------------|--------------------|-------------|



Service provider information

|   |                                 |    |                                  |
|---|---------------------------------|----|----------------------------------|
| 1 | 12R9749                         | 1  | Bulk power assembly              |
| 2 | See <a href="#">Power parts</a> | AR | Bulk power distribution assembly |
| 3 | See <a href="#">Power parts</a> | 1  | Bulk power controller assembly   |
| 4 | See <a href="#">Power parts</a> | AR | Bulk power regulator assembly    |
| 5 | See <a href="#">Power parts</a> | 1  | Bulk power fan                   |
| 6 | 44P0550                         | 1  | Cover, bulk power fan            |

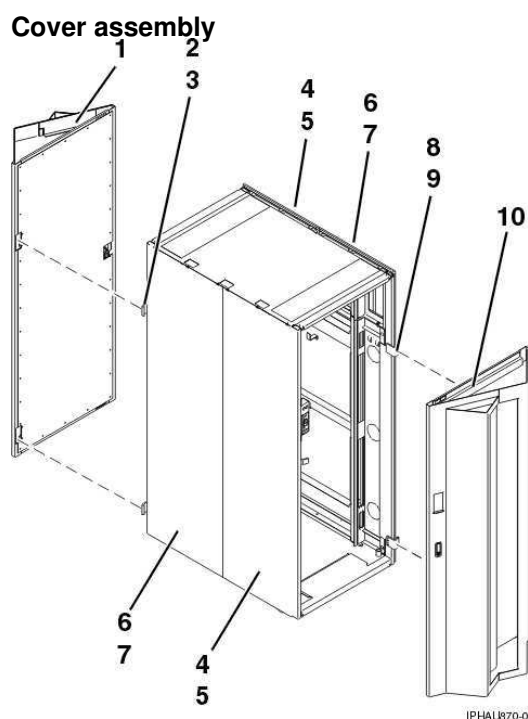


Table 3. Cover assembly part numbers

| Index number | Part number | Units per assembly | Description                   |
|--------------|-------------|--------------------|-------------------------------|
| 1            | 41U0395     | AR                 | Cover kit (acoustical)        |
|              | 41U0392     | AR                 | Cover kit (slim)              |
|              |             | AR                 | Cover kit, 86/91 (acoustical) |
|              | 41U0393     | AR                 | Cover kit, 86/91 (slim)       |
|              | 44P2670     | AR                 | Filter, cover                 |
| 2            | 11P4106     | 2                  | Hinge, back cover             |
| 3            | 2665525     | 4                  | Screw, hinge                  |
| 4            | 44P0126     | 2                  | Cover, right-side             |
| 5            | 54G2882     | 3                  | Screw, cover mounting         |
| 6            | 44P0125     | 2                  | Cover, left-side              |
| 7            | 54G2882     | 3                  | Screw, cover mounting         |
| 8            | 11P3535     | 2                  | Hinge, front cover            |

|    |                    |   |              |
|----|--------------------|---|--------------|
| 9  | 2665525            | 4 | Screw, hinge |
| 10 | See index number 1 | 1 | Cover kit    |

**Processor subsystem assembly**

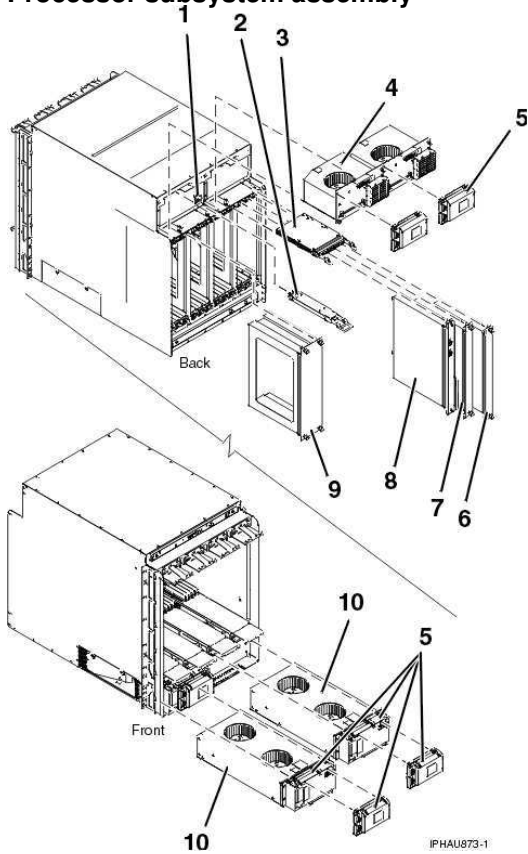


Table 4. Processor subsystem assembly part numbers

| Index number | Part number                         | Units per assembly | Description                                           |
|--------------|-------------------------------------|--------------------|-------------------------------------------------------|
| 1            | See <a href="#">VPD parts</a>       | 1                  | VPD card                                              |
| 2            | See <a href="#">Processor parts</a> | 1                  | Oscillator (clock) card                               |
| 3            | See <a href="#">Processor parts</a> | AR                 | Service processor card                                |
| 4            | 12R9148                             | 1                  | Motor scroll assembly                                 |
| 5            | 41U0341                             | 4                  | Motor drive assembly                                  |
| 6            | 41U0328                             | AR                 | Filler, distributed converter assembly (DCA) - single |
| 7            | 41U0013                             | AR                 | Jumper, distributed converter assembly (DCA)          |
| 8            | 15R6709                             | AR                 | Distributed converter assembly (DCA)                  |
| 9            | 12R6732                             | AR                 | Filler, distributed converter assembly (DCA) - triple |
| 10           | 12R9201                             | 1                  | Blower assembly, right                                |
|              | 12R9200                             | 1                  | Blower assembly, left                                 |
|              |                                     | 1                  | System backplane                                      |

|  |                                     |  |
|--|-------------------------------------|--|
|  | See <a href="#">Backplane parts</a> |  |
|--|-------------------------------------|--|

**Node assembly**

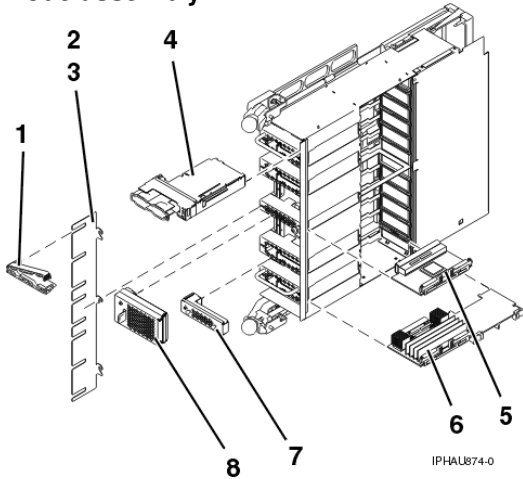


Table 5. Node assembly part numbers

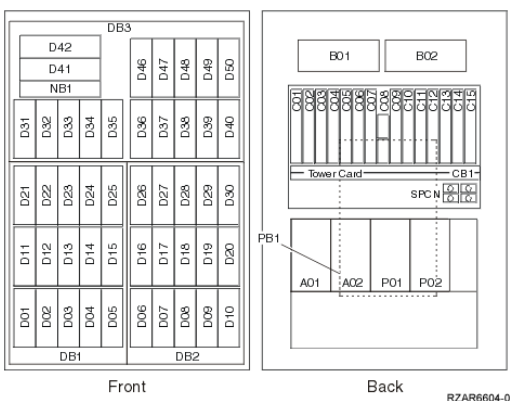
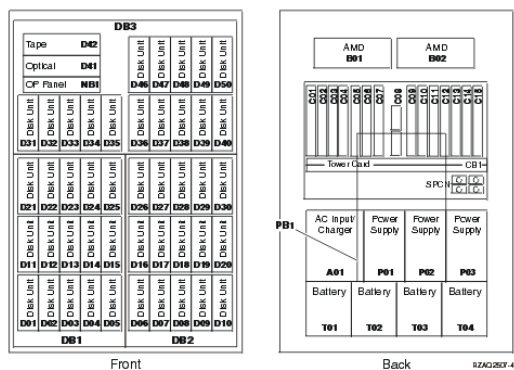
| Index number | Part number                         | Units per assembly | Description              |
|--------------|-------------------------------------|--------------------|--------------------------|
| 1            | 12R7089                             | AR                 | Cable clamp              |
| 2            | 12R7088                             | 1                  | Cable management bracket |
| 3            |                                     | AR                 | Screw                    |
| 4            | See <a href="#">Bus parts</a>       | AR                 | RIO card                 |
| 5            | See <a href="#">Processor parts</a> | AR                 | Multiplexer card         |
| 6            | See <a href="#">Memory parts</a>    | AR                 | Memory card              |
|              | 41V0808                             | AR                 | Filler, memory airflow   |
| 7            | 12R6700                             | AR                 | Baffle, single           |
| 8            | 12R7296                             | AR                 | Baffle, double           |
|              | See <a href="#">Processor parts</a> | AR                 | Processor MCM kit        |
|              | See <a href="#">Backplane parts</a> | 1                  | Node backplane           |

Parent topic: [Part assembly diagrams](#)

## Locations 50/74, 8079-002, and 8093-002 expansion units

**Note:** The known logical location codes for this unit are listed next to the corresponding physical location in the following information. If you are working with a logical location code for this unit and it is not listed in the following information, contact your next level of support.

The following diagram shows the FRU layout in the 50/74 expansion unit. Use it with the following tables.



The following table provides the components available for callout on 50/74, 8079-002, and 8093-002 expansion units. It matches those components with the FRU containing the component. The other columns provide location information, a link to a removal and replacement procedure, and additional information.

**Attention:** After replacing any part on a server or expansion unit, perform [Verifying the repair](#).

Table 1. FRU locations and failing components for 50/74, 8079-002, and 8093-002 expansion units

| Failing item name                                                                                                                                                 | Symbolic failing item name                                                                                | Physical location code | Link to part number  | Failing item removal and replacement procedures                                                       |
|-------------------------------------------------------------------------------------------------------------------------------------------------------------------|-----------------------------------------------------------------------------------------------------------|------------------------|----------------------|-------------------------------------------------------------------------------------------------------|
| Expansion unit backplane<br><ul style="list-style-type: none"> <li>• SPCN</li> <li>• Card enclosure or backplane</li> <li>• Multi-adapter bridge (all)</li> </ul> | TWRCARD<br>MA_BRDG<br>MABRCFG<br>PPCITWR<br>PRI_PCI<br>HSL_LNK<br>PIOCARD<br>MASBUS<br>TWBRKPL<br>TWRPLNR | U <sub>n</sub> -CB1    | <a href="#">28AB</a> | <a href="#">Exchanging the tower card in the 50/74, 50/79, 8079-002, and 8093-002 expansion units</a> |

|                                                                    |                              |                                                                    |                     |                                                                                                          |
|--------------------------------------------------------------------|------------------------------|--------------------------------------------------------------------|---------------------|----------------------------------------------------------------------------------------------------------|
| PCI adapter in slot 1                                              | PIOCARD<br>MASBUS<br>SLOTERR | Un-CB1-C01                                                         | Part number catalog | PCI adapters in the Installing hardware topic.                                                           |
| PCI adapter in slot 2                                              | PIOCARD<br>MASBUS<br>SLOTERR | Un-CB1-C02                                                         |                     |                                                                                                          |
| PCI adapter in slot 3                                              | PIOCARD<br>MASBUS<br>SLOTERR | Un-CB1-C03                                                         |                     |                                                                                                          |
| PCI adapter in slot 4                                              | PIOCARD<br>MASBUS<br>SLOTERR | Un-CB1-C04                                                         |                     |                                                                                                          |
| PCI adapter in slot 5                                              | PIOCARD<br>MASBUS<br>SLOTERR | Un-CB1-C05                                                         |                     |                                                                                                          |
| PCI adapter in slot 6                                              | PIOCARD<br>MASBUS<br>SLOTERR | Un-CB1-C06                                                         |                     |                                                                                                          |
| PCI adapter in slot 7                                              | PIOCARD<br>MASBUS<br>SLOTERR | Un-CB1-C07                                                         |                     |                                                                                                          |
| RIO adapter card<br><br>• HSL adapter<br>• PCI host bridge adapter | SIIOADP<br>SIADPCD<br>SI_PHB | Un-CB1-C08                                                         | 2691                | FC 5074, FC 5079, FC 5094, FC 5294 - Cards (dedicated)                                                   |
| PCI adapter in slot 9                                              | PIOCARD<br>MASBUS<br>SLOTERR | Un-CB1-C09                                                         | Part number catalog | PCI adapters in the Installing hardware topic.                                                           |
| PCI adapter in slot 10                                             | PIOCARD<br>MASBUS<br>SLOTERR | Un-CB1-C10                                                         |                     |                                                                                                          |
| PCI adapter in slot 11                                             | PIOCARD<br>MASBUS<br>SLOTERR | Un-CB1-C11                                                         |                     |                                                                                                          |
| PCI adapter in slot 12                                             | PIOCARD<br>MASBUS<br>SLOTERR | Un-CB1-C12                                                         |                     |                                                                                                          |
| PCI adapter in slot 13                                             | PIOCARD<br>MASBUS<br>SLOTERR | Un-CB1-C13                                                         |                     |                                                                                                          |
| PCI adapter in slot 14                                             | PIOCARD<br>MASBUS<br>SLOTERR | Un-CB1-C14                                                         |                     |                                                                                                          |
| PCI adapter in slot 15                                             | PIOCARD<br>MASBUS<br>SLOTERR | Un-CB1-C15                                                         |                     |                                                                                                          |
| PCI bridge set 1                                                   | BRDGSET<br>BRDGST1           | Un-CB1-C01<br>Un-CB1-C02<br>Un-CB1-C03<br>Un-CB1-C04               |                     | Replace the cards using the removal and replacement procedures corresponding to the locations indicated. |
| PCI bridge set 2                                                   | BRDGSET<br>BRDGST2           | Un-CB1-C05<br>Un-CB1-C06<br>Un-CB1-C07<br>Un-CB1-C09<br>Un-CB1-C10 |                     |                                                                                                          |

Service provider information

|                                        |                    |                                                                    |                                                                           |                                                                                                                  |
|----------------------------------------|--------------------|--------------------------------------------------------------------|---------------------------------------------------------------------------|------------------------------------------------------------------------------------------------------------------|
| PCI bridge set 3                       | BRDGSET<br>BRDGST3 | Un-CB1-C11<br>Un-CB1-C12<br>Un-CB1-C13<br>Un-CB1-C14<br>Un-CB1-C15 |                                                                           |                                                                                                                  |
| Fan 1                                  |                    | Un-B01                                                             | Part assembly diagrams for 50/74, 50/94, 82/94, and 91/94 expansion units | Exchanging the air-moving devices in the 50/74, 50/79, 8079-002, and 8093-002 expansion units                    |
| Fan 2                                  |                    | Un-B02                                                             |                                                                           |                                                                                                                  |
| Power board                            |                    | Un-PB1                                                             | Part assembly diagrams for 50/74, 50/94, 82/94, and 91/94 expansion units | Exchanging the power distribution board in the 50/74, 50/79, 8079-002, and 8093-002 expansion units              |
| AC module / charger (single line cord) |                    | Un-A01                                                             | Part assembly diagrams for 50/74, 50/94, 82/94, and 91/94 expansion units | Exchanging the ac charger (A01) in the 50/74, 50/79, 8079-002, and 8093-002 expansion units (single line cord)   |
| AC module (dual line cord)             |                    | Un-A01                                                             | Part assembly diagrams for 50/74, 50/94, 82/94, and 91/94 expansion units | Exchanging ac modules (A01 and A02) in the 50/74, 50/79, 8079-002, and 8093-002 expansion units (dual line cord) |
| AC module (dual line cord)             |                    | Un-A02                                                             |                                                                           |                                                                                                                  |
| Power supply 1                         |                    | Un-P01                                                             | Part assembly diagrams for 50/74, 50/94, 82/94, and 91/94 expansion units | Exchanging the power supplies in the 50/74, 50/79, 8079-002, and 8093-002 expansion units                        |
| Power supply 2                         |                    | Un-P02                                                             |                                                                           |                                                                                                                  |
| Power supply 3                         |                    | Un-P03                                                             |                                                                           |                                                                                                                  |
| Battery 1                              |                    | Un-T01                                                             | Power parts                                                               | Exchanging the batteries in the 50/74, 50/79, 8079-002, and 8093-002 expansion units                             |
| Battery 2                              |                    | Un-T02                                                             |                                                                           |                                                                                                                  |
| Battery 3                              |                    | Un-T03                                                             |                                                                           |                                                                                                                  |
| Battery 4                              |                    | Un-T04                                                             |                                                                           |                                                                                                                  |
| Device board 1                         |                    | Un-DB1                                                             | 283D                                                                      | Exchanging the device boards in the 50/74, 50/79, 8079-002, and 8093-002 expansion units                         |
| Device board 2                         |                    | Un-DB2                                                             |                                                                           |                                                                                                                  |
| Device board 3                         |                    | Un-DB3                                                             | 283C                                                                      | Exchanging the device boards in the 50/74, 50/79, 8079-002, and 8093-002 expansion units                         |
| Display panel                          |                    | Un-NB1                                                             | 247B                                                                      | Exchanging the control panel in the 50/74, 50/79, 8079-002, and 8093-002 expansion units                         |
| Disk units 1 5                         |                    | Un-DB1-D01<br>Un-DB1-D02<br>Un-DB1-D03<br>Un-DB1-D04<br>Un-DB1-D05 | Part number catalog                                                       | Disk unit recovery procedures                                                                                    |
| Disk units 6 10                        |                    | Un-DB2-D06<br>Un-DB2-D07<br>Un-DB2-D08<br>Un-DB2-D09               | Part number catalog                                                       | Disk unit recovery procedures                                                                                    |

Service provider information

|                            |                                               |                                                                                                                                                                                                                          |                     |                                                                     |
|----------------------------|-----------------------------------------------|--------------------------------------------------------------------------------------------------------------------------------------------------------------------------------------------------------------------------|---------------------|---------------------------------------------------------------------|
|                            |                                               | <i>Un</i> -DB2-D10                                                                                                                                                                                                       |                     |                                                                     |
| Disk units<br>11 15        |                                               | <i>Un</i> -DB1-D11<br><i>Un</i> -DB1-D12<br><i>Un</i> -DB1-D13<br><i>Un</i> -DB1-D14<br><i>Un</i> -DB1-D15                                                                                                               | Part number catalog | Disk unit recovery procedures                                       |
| Disk units<br>16 20        |                                               | <i>Un</i> -DB2-D16<br><i>Un</i> -DB2-D17<br><i>Un</i> -DB2-D18<br><i>Un</i> -DB2-D19<br><i>Un</i> -DB2-D20                                                                                                               | Part number catalog | Disk unit recovery procedures                                       |
| Disk units<br>21 25        |                                               | <i>Un</i> -DB1-D21<br><i>Un</i> -DB1-D22<br><i>Un</i> -DB1-D23<br><i>Un</i> -DB1-D24<br><i>Un</i> -DB1-D25                                                                                                               | Part number catalog | Disk unit recovery procedures                                       |
| Disk units<br>26 30        |                                               | <i>Un</i> -DB2-D26<br><i>Un</i> -DB2-D27<br><i>Un</i> -DB2-D28<br><i>Un</i> -DB2-D29<br><i>Un</i> -DB2-D30                                                                                                               | Part number catalog | Disk unit recovery procedures                                       |
| Disk units<br>31 40        |                                               | <i>Un</i> -DB3-D31<br><i>Un</i> -DB3-D32<br><i>Un</i> -DB3-D33<br><i>Un</i> -DB3-D34<br><i>Un</i> -DB3-D35<br><i>Un</i> -DB3-D36<br><i>Un</i> -DB3-D37<br><i>Un</i> -DB3-D38<br><i>Un</i> -DB3-D39<br><i>Un</i> -DB3-D40 | Part number catalog | Disk unit recovery procedures                                       |
| Optical                    |                                               | <i>Un</i> -DB3-D41                                                                                                                                                                                                       | Part number catalog | Media device in an expansion unit in the Installing hardware topic. |
| Tape                       |                                               | <i>Un</i> -DB3-D42                                                                                                                                                                                                       |                     |                                                                     |
| Disk units<br>46 50        |                                               | <i>Un</i> -DB3-D46<br><i>Un</i> -DB3-D47<br><i>Un</i> -DB3-D48<br><i>Un</i> -DB3-D49<br><i>Un</i> -DB3-D50                                                                                                               | Part number catalog | Disk unit recovery procedures                                       |
| RIO adapter card connector | HSL_LNK<br>HSL2<br>HSL2_xx<br>HSLH<br>HSLH_xx | <i>Un</i> -CB1-C08-00                                                                                                                                                                                                    | Part number catalog | Exchanging RIO cables                                               |
| RIO adapter card connector | HSL_LNK<br>HSL2<br>HSL2_xx<br>HSLH<br>HSLH_xx | <i>Un</i> -CB1-C08-01                                                                                                                                                                                                    |                     |                                                                     |

**Notes:**

1. Card position C01 must be a processor.
2. Card positions C05 and C11 must be processors.
3. J11 is an RPO connection, J14 is an uninterruptible power supply (UPS) connector, J15 is an SPCN 1 connector, and J16 is an SPCN 2 connector.
4. Multi-adapter bridge domains are labeled PCI Bridge Set inside the unit.
5. The following table provides information necessary to identify the input/output processor (IOP) to which input/output adapters (IOAs) are assigned.

- ◆ The left column indicates the domain in which IOA assignment is allowed.
- ◆ The right column is used to determine the IOP to which an IOA is assigned.
- ◆ The first position in the list must be an IOP. The remaining positions may be IOPs or IOAs. IOAs are assigned to the first IOP located to their left in the list. Although IOAs can be manually reassigned using SST/DST, the IOA assignments return to the default order after each IPL.

Table 2. IOA assignment rules

| Multi-adapter bridge domain / PCI bridge set | IOA assignment rules    |
|----------------------------------------------|-------------------------|
| C01 - C04                                    | C01, C02, C03, C04      |
| C05 - C10 (Not including C08)                | C05, C06, C07, C09, C10 |
| C11 - C15                                    | C11, C12, C13, C14, C15 |

Parent topic: [Finding part locations](#)

## Exchanging the tower card in the 50/74, 50/79, 8079-002, and 8093-002 expansion units

Use this procedure in conjunction with [Powering off an expansion unit](#) to remove or replace the tower card (CB1) in the 50/74, 50/79, 8079-002, and 8093-002 expansion units.

1. Power off the expansion unit using [Powering off an expansion unit](#), then continue with the next step.
  2. Open the rear cover. See [Exchanging the covers in the 50/74, 50/79, 50/94, 52/94, 8079-002, 8093-002, 8094-002, and 82/94 expansion units](#).
  3. Disconnect the power cords at each power supply from the unit you are working on (if you have not already done so).
  4. From the rear of the expansion unit do the following:
    - a. Remove the external cables from the rear of the PCI card enclosure and record their card and port locations.
    - b. Remove the EMC access plate that is located directly above the PCI card enclosure. Press the surfaces of the two latching mechanisms together and tilt the top of the cover away from the frame to remove it.
    - c. Remove the cables from the top of the PCI cards and record their card and port locations.
- Attention:** All cards are sensitive to electrostatic discharge. See [Working with electrostatic discharge-sensitive parts](#).
- d. Remove the screws that hold the PCI card enclosure to the frame.
  - e. Pull the PCI card enclosure partially out of the frame while lifting the cables clear of the enclosure.
  - f. Press the release mechanism that is located along the top right side of the enclosure and carefully slide the enclosure towards you. Make sure that the cables are clear of the enclosure.
5. Remove the PCI cards and HSL/RIO bridge adapter from the enclosure and note their locations. See [Exchanging cards \(dedicated\) in the 50/74, 50/79, 50/94, 52/94, 8079-002, 8093-002, 8094-002, and 82/94 expansion units](#).
  6. Install the new PCI card enclosure by reversing the above procedure.
  7. Reconnect the power cord(s) and/or the power supply cords that you disconnected earlier.

**Note:** The tower will power on automatically.



8. Perform [Setting expansion unit configuration ID and MTMS value](#) and then continue with the next step of this procedure.
9. Go to [Verifying the repair](#). This ends the procedure.

**Parent topic:** [Removing and replacing parts in the 50/74, 50/79, 8079-002, and 8093-002 expansion units](#)

## Part assembly diagrams for 50/74, 50/94, 82/94, and 91/94 expansion units

### Cover assembly for 50/74, 50/94, 82/94, and 91/94 expansion units

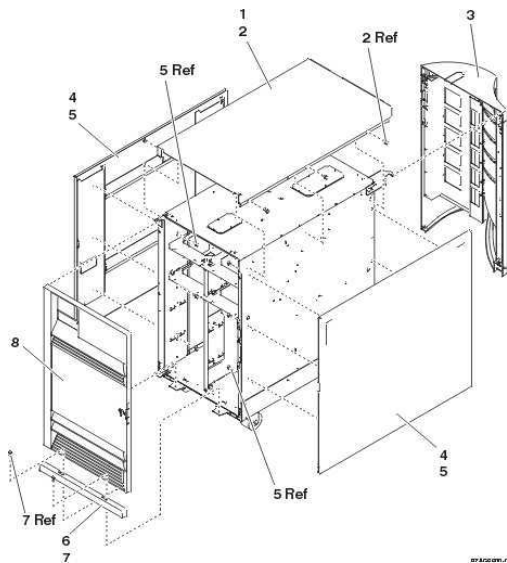


Table 1. Cover assembly part numbers

| Index | Part number | Units | Description        |
|-------|-------------|-------|--------------------|
| 1     | 39J4314     | 1     | Top cover          |
| 2     | 1621811     | 4     | Screw, M4 (10mm)   |
|       | 24L1079     | 1     | Back cover         |
|       | 24L1071     | 1     | Hinge pin, top     |
| 4     | 39J4313     | 1     | Side cover         |
| 5     | 1621811     | 12    | Screw, M4 (10mm)   |
| 6     | 24L1078     | 1     | Front filler cover |
| 7     | 1621811     | 2     | Screw, M4 (10mm)   |
| 8     | 24L1069     | 1     | Front cover        |
|       | 24L1071     |       | Hinge pin, top     |

### Final assembly for 50/74, 50/94, 82/94, and 91/94 expansion units

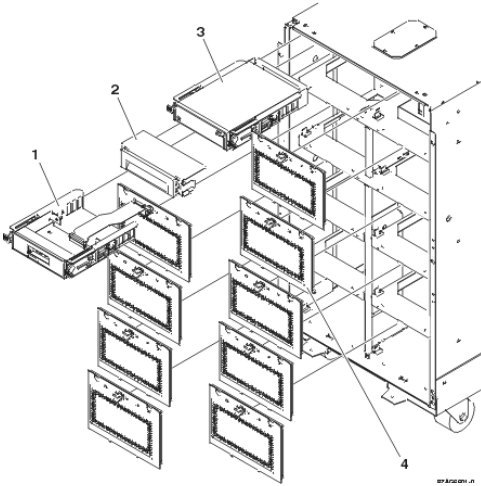


Table 2. Final assembly part numbers

| Index | Part number                                      | Units | Description                |
|-------|--------------------------------------------------|-------|----------------------------|
| 1     | See <a href="#">System parts</a>                 | 1     | Display panel              |
| 2     | 42R4037                                          | AR    | Filler (removable media)   |
| 2     | See <a href="#">System parts</a>                 | AR    | Optical storage unit       |
| 3     | See <a href="#">Removable media device parts</a> | AR    | Removable media.           |
| 4     | 42R4045                                          | AR    | Disk unit EMC access plate |

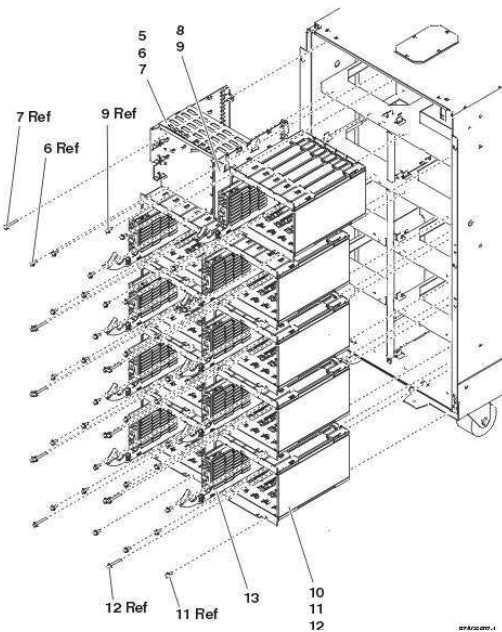


Table 3. Final assembly part numbers

| Index | Part number | Units | Description                        |
|-------|-------------|-------|------------------------------------|
| 5     | NONUM       | 1     | Removable media enclosure assembly |
| 6     | 1621811     | 2     | Screw, M4 (10mm)                   |
| 7     | 1621817     | 2     | Screw                              |
| 8     | 39J5598     | 1     | Center support bracket             |
| 9     | 1621811     | 2     | Screw, M4 (10mm)                   |

Service provider information

|    |                                     |    |                                   |
|----|-------------------------------------|----|-----------------------------------|
| 10 | NONUM                               | AR | Five disk unit enclosure assembly |
| 11 | 1621811                             | 12 | Screw, M4 (10mm)                  |
| 12 | 1621817                             | 6  | Screw                             |
| 13 | See <a href="#">Disk unit parts</a> | AR | Disk unit assembly                |

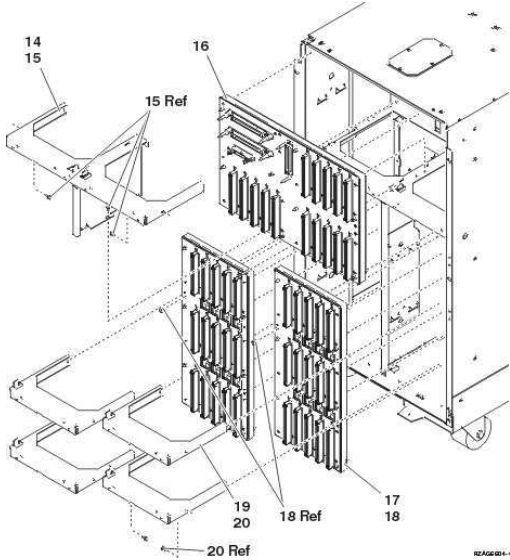


Table 4. Final assembly part numbers

| Index | Part number     | Units | Description                                     |
|-------|-----------------|-------|-------------------------------------------------|
| 14    | NONUM           | 1     | Shelf, base disk unit                           |
| 15    | 1621811         | 3     | Screw, M4 (10mm)                                |
| 16    | 24L0892         | 1     | Base disk unit board/stiffener assembly (50/74) |
|       | 42R3859         | 1     | Base disk unit board/stiffener assembly (50/94) |
| 17    | 39J2931 (50/74) | AR    | Disk unit board/stiffener assembly              |
|       | 39J2931 (50/94) |       |                                                 |
| 18    | 1621838         | 1     | Screw                                           |
| 19    | NONUM           | AR    | Shelf, disk unit                                |
| 20    | 1621811         | 2     | Screw, M4 (10mm)                                |

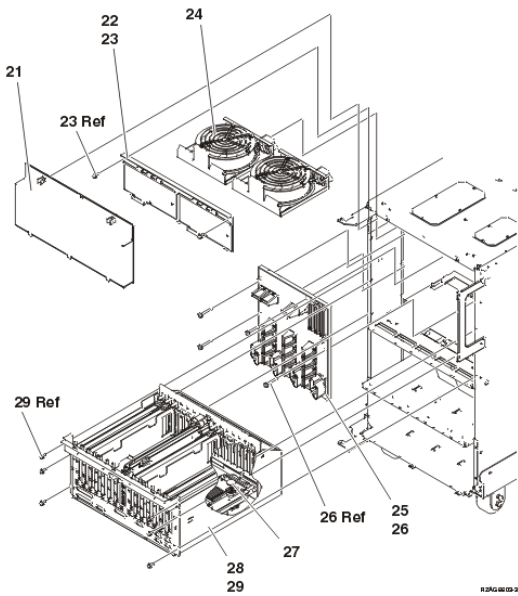


Table 5. Final assembly part numbers

| Index | Part number                         | Units | Description                                  |
|-------|-------------------------------------|-------|----------------------------------------------|
| 21    | 42R4046                             | 1     | EMC access plate                             |
| 22    | NONUM                               | 1     | Air-moving device (fan) door assembly        |
| 23    | 1621811                             | 2     | Screw, M4 (10mm)                             |
| 24    | 39J5235                             | 2     | Air-moving device (fan)                      |
| 25    | 39J3082                             | 1     | Power board/stiffener assembly               |
| 26    | 1621816                             | 6     | Screw                                        |
| 27    | See <a href="#">Power parts</a>     | 1     | Time of day (TOD) battery                    |
| 28    | See <a href="#">Backplane parts</a> | 1     | I/O backplane (50/74)                        |
|       | See <a href="#">Backplane parts</a> | 1     | I/O backplane (50/94)                        |
| 29    | 1621811                             | 6     | Screw, M4 (10mm)                             |
|       |                                     |       | <b>Note:</b> This applies only to the 50/74. |

**Final assembly for 50/74 (single line cord)**

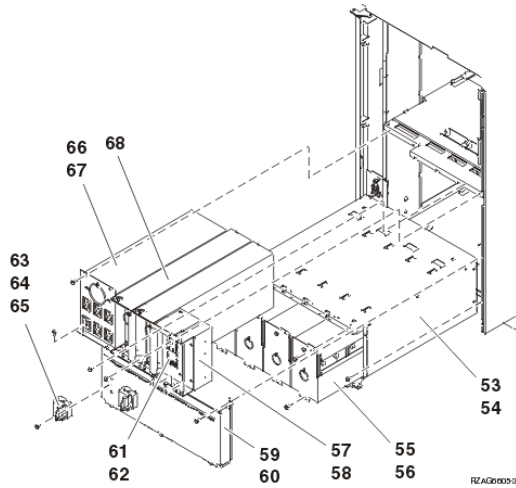


Table 6. Final assembly part numbers for 50/74 (single line cord)

| Index | Part number | Units | Description                                                                                                                       |
|-------|-------------|-------|-----------------------------------------------------------------------------------------------------------------------------------|
| 53    | 42R4092     | 1     | Power subframe assembly                                                                                                           |
| 54    | 1621811     | 12    | Screw, M4 (10mm)                                                                                                                  |
| 55    | 97H7318     | 1     | Battery pack. This part number includes four batteries. For additional information, refer to symbolic FRU <a href="#">BATRY</a> . |
| 56    | 1621811     | 12    | Screw, M4 (10mm)                                                                                                                  |
| 57    | 39J5845     | AR    | Filler, spacer                                                                                                                    |
| 58    | 1621811     | 2     | Screw, M4 (10mm)                                                                                                                  |
| 59    | NONUM       | 1     | EMC access plate                                                                                                                  |
| 60    | 1621811     | 2     | Screw, M4 (10mm)                                                                                                                  |
| 61    | 24L0939     | AR    | Filler, power supply                                                                                                              |
| 62    | 1621811     | 2     | Screw, M4 (10mm)                                                                                                                  |
| 63    | 44H8641     | 2     | Cable clamp, top                                                                                                                  |
| 64    | 44H8640     | 2     | Cable clamp, base                                                                                                                 |
| 65    | 1621811     | 2     | Screw, M4 (10mm)                                                                                                                  |
| 66    | 97H7316     | 1     | Battery charger                                                                                                                   |
| 67    | 1621811     | 4     | Screw, M4 (10mm)                                                                                                                  |
| 68    | 90H6629     | 3     | Power supply, 765 watts (P01, P02, P03)                                                                                           |

**Final assembly for 50/74 (two power supply dual line cord)**

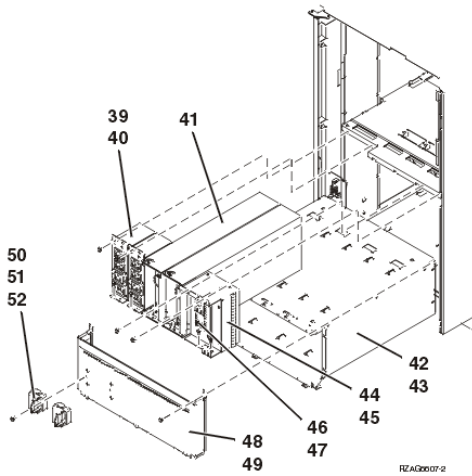


Table 7. Final assembly part numbers for 50/74 (two power supply dual line cord)

| Index | Part number | Units | Description             |
|-------|-------------|-------|-------------------------|
| 39    | 21P6347     | 2     | AC module               |
| 40    | 1621811     | 4     | Screw, M4 (10mm)        |
| 41    | 39J5273     | 2     | Power supply, 840 watts |
| 42    | 42R4092     | 1     | Power subframe assembly |
| 43    | 1621811     | 12    | Screw, M4 (10mm)        |
| 44    | 39J5845     | AR    | Filler, Spacer          |
| 45    | 1621811     | 2     | Screw, M4 (10mm)        |
| 46    | 24L0939     | AR    | Filler, power supply    |
| 47    | 1621811     | 2     | Screw, M4 (10mm)        |
| 48    | NONUM       | 1     | EMC access plate        |
| 49    | 1621811     | 2     | Screw, M4 (10mm)        |
| 50    | 44H8641     | 2     | Cable clamp, Top        |
| 51    | 44H8640     | 2     | Cable clamp, Base       |
| 52    | 1621811     | 2     | Screw, M4 (10mm)        |

**Final assembly for 50/94, 82/94, and 91/94 expansion units**

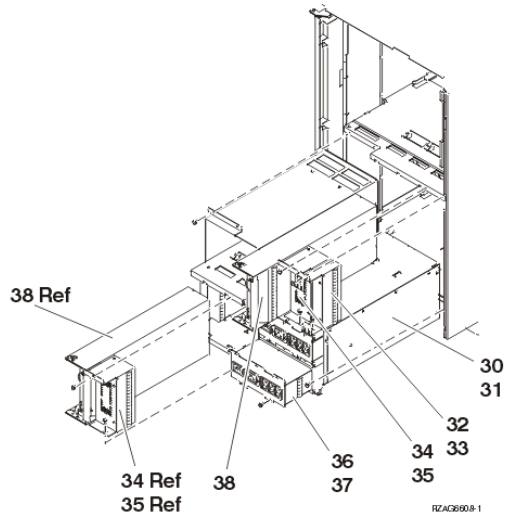


Table 8. Final assembly part numbers for 50/94, 82/94, and 91/94 expansion unit

| Index | Part number | Units | Description                                                                |
|-------|-------------|-------|----------------------------------------------------------------------------|
| 30    | 42R4295     | 1     | Power subframe assembly for dual line cord                                 |
| 31    | 1621811     | 8     | Screw, M4 (10mm)                                                           |
| 32    | 39J5845     | 2     | Filler, spacer                                                             |
| 33    | 1621811     | 2     | Screw, M4 (10mm)                                                           |
| 34    | 24L0939     | 2     | Filler, power supply                                                       |
| 35    | 1621811     | 4     | Screw, M4 (10mm)                                                           |
| 36    | 39J5171     | 2     | AC power distribution assembly. See symbolic FRU <a href="#">ACMODUL</a> . |
| 37    | 1621811     | 4     | Screw, M4 (10mm)                                                           |
| 38    | 39J5273     | 4     | Power supply assembly - 840W                                               |

Parent topic: [Part assembly diagrams](#)

## Exchanging the air-moving devices in the 50/74, 50/79, 8079-002, and 8093-002 expansion units

Use this procedure to remove or replace the air-moving device (AMD) (B01 and B02) in the 50/74, 50/79, 8079-002, and 8093-002 expansion unit.

**Attention:** Since this procedure can be performed concurrently, you do not need to power off the unit if it is already powered on.

1. Open the rear cover (see [Exchanging the covers in the 50/74, 50/79, 50/94, 52/94, 8079-002, 8093-002, 8094-002, and 82/94 expansion units](#)).

2. Remove the EMC access plate located directly above the PCI card enclosure. Press the surfaces of the two latches together, and tilt the top of the cover away from the frame to remove it.
3. Remove the screw from the AMD door assembly for the AMD that you are replacing.
4. Remove the AMD assembly by sliding it out of the enclosure, while holding the AMD access plate open.
5. Install the new AMD by reversing this procedure. The new AMD will automatically power on after it is installed.
6. After exchanging an item, go to [Verifying the repair](#).

This ends the procedure.

**Parent topic:** [Removing and replacing parts in the 50/74, 50/79, 8079-002, and 8093-002 expansion units](#)

---

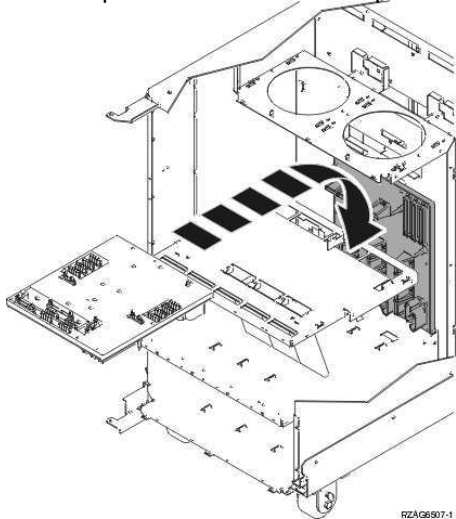
## Exchanging the power distribution board in the 50/74, 50/79, 8079-002, and 8093-002 expansion units

Use this procedure to remove or replace the power distribution board (PB1) in the 50/74, 50/79, 8079-002, and 8093-002 expansion units.

1. [Removing and replacing the device board \(DB1 and DB2\)](#). Continue with the next step.
2. From the rear of the expansion unit, do the following:
  - a. Open the rear cover (see [Exchanging the covers in the 50/74, 50/79, 50/94, 52/94, 8079-002, 8093-002, 8094-002, and 82/94 expansion units](#)).
  - b. Remove the EMC access plate that is located directly above the PCI card enclosure. Press the surfaces of the two latching mechanisms together and tilt the top of the cover away from the frame to remove it.
  - c. Remove the cables from the disk unit controller cards that are located inside the PCI card enclosure and record their card and port locations. All cards are sensitive to electrostatic discharge (see [Working with electrostatic discharge-sensitive parts](#)).
  - d. Remove the screws that hold the PCI card enclosure to the frame.
  - e. Pull the PCI card enclosure partially out of the frame while lifting the cables clear of the enclosure.
  - f. Press the release mechanism that is located along the top right side of the enclosure and carefully slide the enclosure towards you. Make sure that the cables are clear of the enclosure. Then continue with the next step.
3. Are you working on a dual line cord unit?
  - ◆ Yes: Perform the following:
    - a. Remove the ac modules (see [Exchanging ac modules \(A01 and A02\) in the 50/74, 50/79, 8079-002, and 8093-002 expansion units \(dual line cord\)](#)).
    - b. Remove the power supplies (see [Exchanging the power supplies in the 50/74, 50/79, 8079-002, and 8093-002 expansion units](#)).
    - c. Remove the blank filler plate(s).
    - d. Continue with the next step.
  - ◆ No: Perform the following:
    - a. Remove the ac charger (see [Exchanging the ac charger \(A01\) in the 50/74, 50/79, 8079-002, and 8093-002 expansion units \(single line cord\)](#)).
    - b. Remove the power supplies (see [Exchanging the power supplies in the 50/74, 50/79, 8079-002, and 8093-002 expansion units](#)).
    - c. Remove the blank filler plate(s).
    - d. Remove the four batteries (see [Exchanging the batteries in the 50/74, 50/79, 8079-002, and 8093-002 expansion units](#)).
    - e. Continue with the next step.
4. Remove the screws from the power subframe assembly.
5. From the front of the tower, reach through the frame and remove the cables from the back side of the power distribution backplane and note their locations.
6. From the rear of the tower, remove the mounting screws that hold the power distribution backplane to the frame.



7. Pull the power distribution backplane slightly towards you and lift it up to remove it from the frame.



8. Install the power distribution backplane by reversing the removal procedure. After exchanging an item, go to [Verifying the repair](#). This ends the procedure.

**Parent topic:** [Removing and replacing parts in the 50/74, 50/79, 8079-002, and 8093-002 expansion units](#)

---

## Exchanging the ac charger (A01) in the 50/74, 50/79, 8079-002, and 8093-002 expansion units (single line cord)

Use this procedure to remove or replace the ac charger (A01) in a single line cord 50/74, 50/79, 8079-002, and 8093-002 expansion units.

1. Power off the expansion unit (see [Powering off an expansion unit](#)).
2. Open the rear cover (see [Exchanging the covers in the 50/74, 50/79, 50/94, 52/94, 8079-002, 8093-002, 8094-002, and 82/94 expansion units](#)).
3. Disconnect the incoming ac power cord from the expansion unit.
4. Disconnect all the power cords from the battery charger.
5. Remove the screws that are holding the charger to the frame.
6. Remove the battery charging unit.
7. Install the new ac charger by reversing this procedure. After exchanging an item, go to [Verifying the repair](#). This ends the procedure.

**Parent topic:** [Removing and replacing parts in the 50/74, 50/79, 8079-002, and 8093-002 expansion units](#)

---

## Exchanging ac modules (A01 and A02) in the 50/74, 50/79, 8079-002, and 8093-002 expansion units (dual line cord)

Use this procedure to remove or replace the ac module (A01 and A02) in the dual line cord 50/74, 50/79, 8079-002, and 8093-002 expansion units.

**Attention:** Because this procedure can be performed concurrently, you do not need to power off the unit if it is already powered on.

1. Open the back cover (see [Exchanging the covers in the 50/74, 50/79, 50/94, 52/94, 8079-002, 8093-002, 8094-002, and 82/94 expansion units](#)).
2. Trace and disconnect the ac input line cord that connects to the ac module that needs replacing. Refer to [Locations 50/74, 8079-002, and 8093-002 expansion units](#) or [Locations 50/79 expansion unit](#) for location and address information.

**Attention:** Do not disconnect the other system ac line cord when powered on.

3. Disconnect the power supply jumper cords from the ac module that you are working on.

**Attention:** Do not disconnect the other system ac module power supply jumper cords.

4. Remove the top and bottom screws that hold the ac module to the frame.
5. Remove the ac module unit.
6. Install a new ac module by reversing this procedure. After exchanging an item, go to [Verifying the repair](#).

This ends the procedure.

**Parent topic:** [Removing and replacing parts in the 50/74, 50/79, 8079-002, and 8093-002 expansion units](#)

---

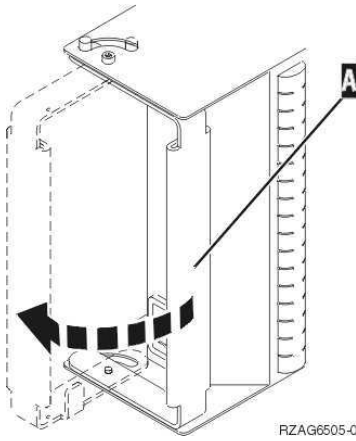
## Exchanging the power supplies in the 50/74, 50/79, 8079-002, and 8093-002 expansion units

Use this procedure to remove or replace the power supply (P00, P01, P02, and P03) in the 50/74, 50/79, 8079-002, and 8093-002 expansion units.

1. Is the system powered on?
  - ◆ Yes: Do not power off the system. Continue with the next step.
  - ◆ No: Continue with the next step.
2. Open the rear cover (see [Exchanging the covers in the 50/74, 50/79, 50/94, 52/94, 8079-002, 8093-002, 8094-002, and 82/94 expansion units](#)).
3. Disconnect the power jumper cord from the unit that you are replacing.
4. Remove the bottom screw (if installed).
5. Rotate the handle from right to left to release the power supply from the frame.

**CAUTION:**The power distribution outlets provide 200 to 240 V ac. Use these outlets only for devices that operate within this voltage range. (C021)

6. Remove the power supply from the frame.



7. Install the new power supply by reversing this procedure. Do not use excessive force when installing the power supply into the system. Insert it until the power supply engages the frame, then rotate the handle from left to right. After exchanging an item, go to [Verifying the repair](#). This ends the procedure.

**Parent topic:** [Removing and replacing parts in the 50/74, 50/79, 8079-002, and 8093-002 expansion units](#)

## Exchanging the batteries in the 50/74, 50/79, 8079-002, and 8093-002 expansion units

Use this procedure to remove or replace the batteries (T01, T02, T03, and T04) in the 50/74, 50/79, 8079-002, and 8093-002 expansion units.

**Attention:** Since this procedure can be performed concurrently, you do not need to power off the unit if it is already powered on. However, removing the battery power unit while the system is running on battery power will cause the system to fail and may damage the battery power unit and the PCI card enclosure. (If the console will accept commands, the system is not running on battery power.)

**CAUTION:** This part or unit is heavy but has a weight smaller than 18 kg (39.7 lb). Use care when lifting, removing, or installing this part or unit. (C008)

1. Open the rear cover (see [Exchanging the covers in the 50/74, 50/79, 50/94, 52/94, 8079-002, 8093-002, 8094-002, and 82/94 expansion units](#)).
2. Remove the screws from the EMC access plate that is covering the batteries.
3. Remove the EMC access plate from the battery enclosure.
4. Remove the top and bottom screws from the battery unit.
5. Remove the battery power unit by using two hands to pull on the ring.

**CAUTION:** Lead-acid batteries can present a risk of electrical burn from high, short-circuit current. Avoid battery contact with metal materials; remove watches, rings, or other metal objects, and use tools with insulated handles. To avoid possible explosion, do not burn.

Exchange only with the approved part. Recycle or discard the battery as instructed by local regulations. (C004a)

6. Install the new battery power unit by reversing this removal procedure. After exchanging an item, go to [Verifying the repair](#). This ends the procedure.

**Parent topic:** [Removing and replacing parts in the 50/74, 50/79, 8079-002, and 8093-002 expansion units](#)

---

## Exchanging the device boards in the 50/74, 50/79, 8079-002, and 8093-002 expansion units

Use this procedure to remove or replace the device board in the 50/74, 50/79, 8079-002, and 8093-002 expansion units.

Use the appropriate procedure depending on the device board you are replacing:

- [Removing and replacing the device board \(DB1 and DB2\)](#)
- [Removing and replacing the device board \(DB3\)](#)

**Parent topic:** [Removing and replacing parts in the 50/74, 50/79, 8079-002, and 8093-002 expansion units](#)

### Removing and replacing the device board (DB1 and DB2)

1. Power off the expansion unit (see [Powering off an expansion unit](#)).
2. Disconnect the power cord from the expansion unit.
3. Open the front cover (see [Exchanging the covers in the 50/74, 50/79, 50/94, 52/94, 8079-002, 8093-002, 8094-002, and 82/94 expansion units](#)).
4. From the front of the expansion unit, do the following:
  - a. Remove the EMC access plates from the disk unit enclosures that are located in front of the backplane that you are replacing. (For location information, see [Locations 50/74, 8079-002, and 8093-002 expansion units](#).) Press the surfaces of the two latching mechanisms together, and tilt the top of the cover away from the frame to remove it.
  - b. Record the locations of the disk units and then remove them from the disk unit enclosures that you just uncovered.

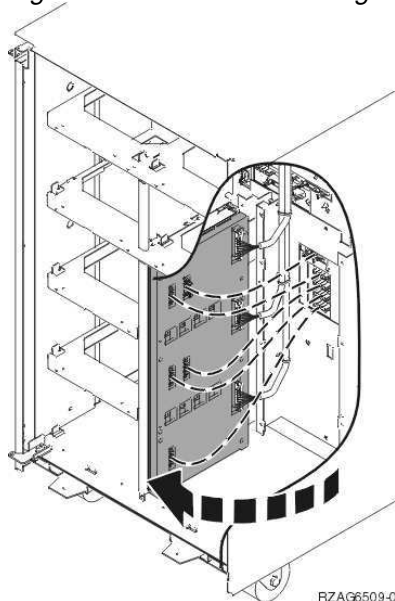
**Attention:** The disk units are sensitive to electrostatic discharge (see [Working with electrostatic discharge-sensitive parts](#)).

- c. Remove the screws that hold the disk unit cage assembly to the frame.
  - d. Remove the two retaining screws that are located inside of the disk unit cage assembly (the top-right and bottom-left corners).
  - e. Remove the disk unit cage assemblies.
  - f. Remove the screws that hold the DASD shelf to the frame.
  - g. Remove the DASD shelf from the frame.
5. Remove the retaining screw that is holding the DASD board assembly to the frame.
  6. Pull the DASD board assembly out until it slides off the guide pins, then rotate the DASD board assembly 90 degrees. Record the locations of the cables that are located on the backside of the board assembly, and then remove them.

**Note:** Both ends of the ribbon cables are marked LH or RH, indicating that one end of the cable is plugged in to either the left-hand (DB1) or right-hand (DB2) DASD board assembly. The other end of

the cable is plugged in to either the left-most (LH) or right-most (RH) DASD controller card. The cables will crisscross in the center of the tower.

Figure 1. Device board cabling



7. Remove the DASD board assembly.
8. Install the DASD board assembly by reversing the removal procedure. After exchanging an item, go to [Verifying the repair](#). This ends the procedure.

### Removing and replacing the device board (DB3)

1. Power off the expansion unit (see [Powering off an expansion unit](#)).
2. Disconnect the power cord from the expansion unit.
3. Open the rear cover (see [Exchanging the covers in the 50/74, 50/79, 50/94, 52/94, 8079-002, 8093-002, 8094-002, and 82/94 expansion units](#)).
4. From the rear of the expansion unit, do the following:
  - a. Remove the EMC access plate that is located directly above the card enclosure. Press the surfaces of the two latching mechanisms together, and tilt the top of the cover away from the frame to remove it.
  - b. Remove the cables from the disk unit controller cards (IOAs) that are located inside the PCI card enclosure and record their card and port locations.
  - c. Remove the screws that hold the tower card enclosure to the frame.
  - d. Pull the tower card enclosure partially out of the frame while lifting the cables clear of the enclosure.
  - e. Press the release mechanism that is located along the top right side of the enclosure and carefully slide the enclosure towards you. Make sure that the cables are clear of the enclosure.
  - f. Remove the tower card enclosure from the frame.
  - g. Remove the screws from the EMC access plate that is located inside the frame and directly above the power distribution board.
  - h. Remove the EMC access plate.
    - i. Reach through the opening and remove the cables from the backside of the base DASD board assembly (DB3).
5. Open the front cover (see [Exchanging the covers in the 50/74, 50/79, 50/94, 52/94, 8079-002, 8093-002, 8094-002, and 82/94 expansion units](#)).
6. From the front of the expansion unit do the following:
  - a. Record the removable media locations and then remove them by pulling out on the handles that are located on each side of the unit.
  - b. Remove the control panel by pulling on the handles that are located on each side of the unit and sliding it partially out of the tower. Then, unplug the cable from the rear of the control panel (see [Exchanging the control panel in the 50/74, 50/79, 8079-002, and 8093-002 expansion units](#)).

- c. Unplug the control panel cable from the base DASD board assembly (DB3).
- d. Remove the two retaining screws that are located inside of the removable media enclosure (the top right and lower left corners).
- e. Remove the removable media enclosure.
- f. Remove the EMC access plates from the disk unit enclosures that are located in front of the backplane (DB3). For location information, see [Locations 50/74, 8079-002, and 8093-002 expansion units](#). Press the surfaces of the two latching mechanisms together and tilt the top of the cover away from the frame to remove it.
- g. Record the disk unit locations and then remove them from the disk unit enclosures that you just uncovered.

**Attention:** The disk units are sensitive to electrostatic discharge (see [Working with electrostatic discharge-sensitive parts](#)).

- h. Remove the screws that hold the disk unit enclosures to the frame.
  - i. Remove the retaining screws that are located inside the disk unit enclosure.
  - j. Remove the disk unit enclosures.
  - k. Remove the screws that hold the center support bracket and shelf for the disk unit and removable media enclosure to the frame.
  - l. Remove the support bracket and shelf.
  - m. Remove the base DASD board assembly (DB3).
7. Install the base DASD board assembly by reversing the removal procedure. After exchanging an item, go to [Verifying the repair](#). This ends the procedure.

---

## Exchanging the control panel in the 50/74, 50/79, 8079-002, and 8093-002 expansion units

Use this procedure to remove or replace the control panel (NB1) in the 50/74, 50/79, 8079-002, and 8093-002 expansion units.

**Attention:** The control panel is sensitive to electrostatic discharge (see [Working with electrostatic discharge-sensitive parts](#)).

1. Power off the expansion unit (see [Powering off an expansion unit](#)).
2. Disconnect the ac power cords from the expansion unit.
3. Open the front cover (see [Exchanging the covers in the 50/74, 50/79, 50/94, 52/94, 8079-002, 8093-002, 8094-002, and 82/94 expansion units](#)).
4. Pull on the two side fasteners to release the control panel assembly.
5. Slide the panel partially out of the frame.
6. Disconnect the cables that are attached to the back side of the control panel.
7. Remove the control panel from the frame.
8. Reverse this procedure to install the new control panel.
9. After exchanging an item, go to [Verifying the repair](#). This ends the procedure.

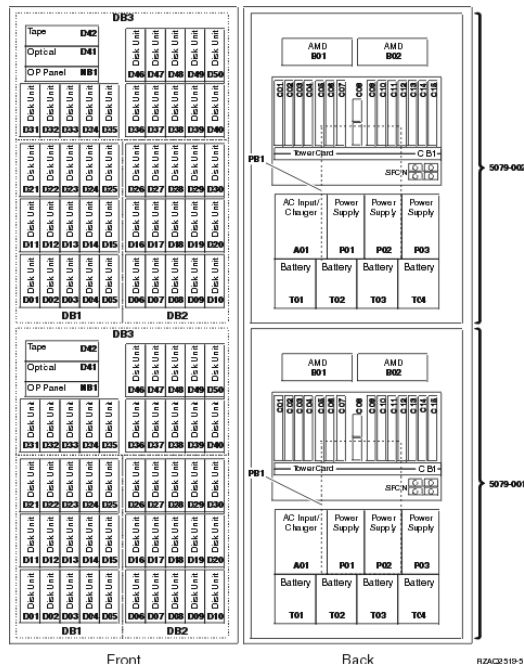
---

**Parent topic:** [Removing and replacing parts in the 50/74, 50/79, 8079-002, and 8093-002 expansion units](#)

## Locations 50/79 expansion unit

The following diagram shows field replaceable unit (FRU) layout in the 50/79 expansion unit. Use the diagram with the information that follows. Service the 50/79 as two independent 50/74 units in the same 1.8 meter rack (see [Locations 50/74](#), [8079-002](#), and [8093-002 expansion units](#)).

**Attention:** After replacing any part on a server or expansion unit, perform [Verifying the repair](#).



Parent topic: [Finding part locations](#)

## Locations 05/88 and 50/88 expansion units

**Note:** The known logical location codes for this unit are listed next to the corresponding physical location in the following information. If you are working with a logical location code for this unit and it is not listed in the following information, contact your next level of support.

The following diagram shows field replaceable unit (FRU) layout in the 05/88 and 50/88 expansion units. Use it with the following tables.

Figure 1. 05/88 and 50/88 expansion units

Service provider information

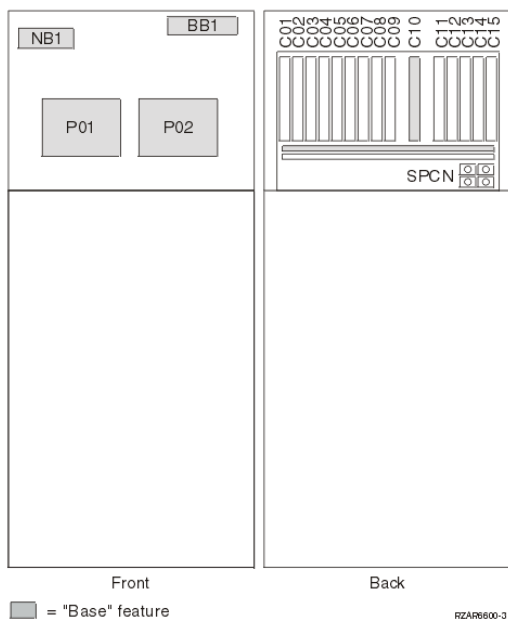
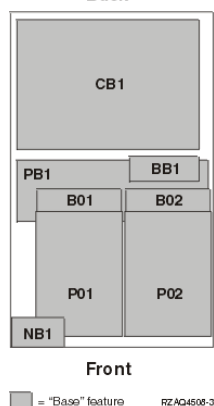


Figure 2. 05/88 and 50/88 expansion units, top view



The following table provides the components available for callout on the 05/88 and 50/88 expansion units. It matches those components with the FRU containing the component. The other columns give location information, a link to a removal and replacement procedure, and additional information.

**Attention:** After replacing any part on a server or expansion unit, perform [Verifying the repair](#).

Table 1. FRU locations and failing components for 05/88 and 50/88 expansion units

| Failing item name                                                                                              | Symbolic failing item name                                                | Physical location code | Link to part number  | Failing item removal and replacement procedures                                  |
|----------------------------------------------------------------------------------------------------------------|---------------------------------------------------------------------------|------------------------|----------------------|----------------------------------------------------------------------------------|
| Expansion unit backplane <ul style="list-style-type: none"> <li>• SPCN</li> <li>• Card enclosure or</li> </ul> | TWRCARD<br>MA_BRDG<br>MABRCFG<br>PPCITWR<br>PRI_PCI<br>HSL_LNK<br>PIOCARD | Un-CB1                 | <a href="#">28B8</a> | <a href="#">Exchanging the tower card in the 50/88 and 05/88 expansion units</a> |



## Service provider information

|                                                                      |                              |            |                        |                                                                                     |
|----------------------------------------------------------------------|------------------------------|------------|------------------------|-------------------------------------------------------------------------------------|
| backplane<br>• Multi-adapter<br>bridge (all)                         | MASBUST<br>WRBKPLT<br>WRPLNR |            |                        |                                                                                     |
| PCI adapter in slot<br>1                                             | PIOCARD<br>MASBUS<br>SLOTERR | Un-CB1-C01 | Part number<br>catalog | Exchanging<br>cards<br>(concurrent) in<br>the 50/88 and<br>05/88 expansion<br>units |
| PCI adapter in slot<br>2                                             | PIOCARD<br>MASBUS<br>SLOTERR | Un-CB1-C02 | Part number<br>catalog | Exchanging<br>cards<br>(concurrent) in<br>the 50/88 and<br>05/88 expansion<br>units |
| PCI adapter in slot<br>3                                             | PIOCARD<br>MASBUS<br>SLOTERR | Un-CB1-C03 | Part number<br>catalog | Exchanging<br>cards<br>(concurrent) in<br>the 50/88 and<br>05/88 expansion<br>units |
| PCI adapter in slot<br>4                                             | PIOCARD<br>MASBUS<br>SLOTERR | Un-CB1-C04 | Part number<br>catalog | Exchanging<br>cards<br>(concurrent) in<br>the 50/88 and<br>05/88 expansion<br>units |
| PCI adapter in slot<br>5                                             | PIOCARD<br>MASBUS<br>SLOTERR | Un-CB1-C05 | Part number<br>catalog | Exchanging<br>cards<br>(concurrent) in<br>the 50/88 and<br>05/88 expansion<br>units |
| PCI adapter in slot<br>6                                             | PIOCARD<br>MASBUS<br>SLOTERR | Un-CB1-C06 | Part number<br>catalog | Exchanging<br>cards<br>(concurrent) in<br>the 50/88 and<br>05/88 expansion<br>units |
| PCI adapter in slot<br>7                                             | PIOCARD<br>MASBUS<br>SLOTERR | Un-CB1-C07 | Part number<br>catalog | Exchanging<br>cards<br>(concurrent) in<br>the 50/88 and<br>05/88 expansion<br>units |
| PCI adapter in slot<br>8                                             | PIOCARD<br>MASBUS<br>SLOTERR | Un-CB1-C08 | Part number<br>catalog | Exchanging<br>cards<br>(concurrent) in<br>the 50/88 and<br>05/88 expansion<br>units |
| PCI adapter in slot<br>9                                             | PIOCARD<br>MASBUS<br>SLOTERR | Un-CB1-C09 | Part number<br>catalog | Exchanging<br>cards<br>(concurrent) in<br>the 50/88 and<br>05/88 expansion<br>units |
| RIO adapter card<br><br>• HSL I/O<br>adapter<br>• PCI host<br>bridge | SIIOADP<br>SIADPCD<br>SI_PHB | Un-CB1-C10 | Part number<br>catalog | Exchanging<br>cards<br>(concurrent) in<br>the 50/88 and<br>05/88 expansion<br>units |

## Service provider information

| adapter                  |                              |                                                                    |                                                                             |                                                                                                     |
|--------------------------|------------------------------|--------------------------------------------------------------------|-----------------------------------------------------------------------------|-----------------------------------------------------------------------------------------------------|
| PCI adapter in slot 11   | PIOCARD<br>MASBUS<br>SLOTERR | Un-CB1-C11                                                         | Part number catalog                                                         | Exchanging cards (concurrent) in the 50/88 and 05/88 expansion units                                |
| PCI adapter in slot 12   | PIOCARD<br>MASBUS<br>SLOTERR | Un-CB1-C12                                                         | Part number catalog                                                         | Exchanging cards (concurrent) in the 50/88 and 05/88 expansion units                                |
| PCI adapter in slot 13   | PIOCARD<br>MASBUS<br>SLOTERR | Un-CB1-C13                                                         | Part number catalog                                                         | Exchanging cards (concurrent) in the 50/88 and 05/88 expansion units                                |
| PCI adapter in slot 14   | PIOCARD<br>MASBUS<br>SLOTERR | Un-CB1-C14                                                         | Part number catalog                                                         | Exchanging cards (concurrent) in the 50/88 and 05/88 expansion units                                |
| PCI adapter in slot 15   | PIOCARD<br>MASBUS<br>SLOTERR | Un-CB1-C15                                                         | Part number catalog                                                         | Exchanging cards (concurrent) in the 50/88 and 05/88 expansion units                                |
| PCI bridge set 1         | BRDGSET<br>BRDGST1           | Un-CB1-C01<br>Un-CB1-C02<br>Un-CB1-C03<br>Un-CB1-C04               |                                                                             | Replace the cards using the remove and replace procedures corresponding to the locations indicated. |
| PCI bridge set 2         | BRDGSET<br>BRDGST2           | Un-CB1-C05<br>Un-CB1-C06<br>Un-CB1-C07<br>Un-CB1-C08<br>Un-CB1-C09 |                                                                             | Replace the cards using the remove and replace procedures corresponding to the locations indicated. |
| PCI bridge set 3         | BRDGSET<br>BRDGST3           | Un-CB1-C11<br>Un-CB1-C12<br>Un-CB1-C13<br>Un-CB1-C14<br>Un-CB1-C15 |                                                                             | Replace the cards using the remove and replace procedures corresponding to the locations indicated. |
| Power distribution board |                              | Un-PB1                                                             | Part assembly diagrams for , 05/88, 50/79, 50/88, and 52/94 expansion units | Exchanging the power distribution board in the 50/88 and 05/88 expansion units                      |
| Power supply 1           |                              | Un-P01                                                             | Part assembly diagrams for , 05/88, 50/79,                                  | Exchanging the power supplies in the 50/88 and                                                      |

Service provider information

|                            |                                               |               |                                                                             |                                                                               |
|----------------------------|-----------------------------------------------|---------------|-----------------------------------------------------------------------------|-------------------------------------------------------------------------------|
|                            |                                               |               | 50/88, and 52/94 expansion units                                            | 05/88 expansion units                                                         |
| Power supply 2             |                                               | Un-P02        | Part assembly diagrams for , 05/88, 50/79, 50/88, and 52/94 expansion units | Exchanging the power supplies in the 50/88 and 05/88 expansion units          |
| Fan 1                      |                                               | Un-B01        | Part assembly diagrams for , 05/88, 50/79, 50/88, and 52/94 expansion units | Exchanging the air-moving device (AMD) in the 50/88 and 05/88 expansion units |
| Fan 2                      |                                               | Un-B02        | Part assembly diagrams for , 05/88, 50/79, 50/88, and 52/94 expansion units | Exchanging the air-moving device (AMD) in the 50/88 and 05/88 expansion units |
| Fan controller card        | AMDCTRL                                       | Un-BB1        | Part assembly diagrams for , 05/88, 50/79, 50/88, and 52/94 expansion units | Exchanging the AMD controller card in the 50/88 and 05/88 expansion units     |
| Display panel              |                                               | Un-NB1        | Part number catalog                                                         | Exchanging the control panel in the 50/88 and 05/88 expansion units           |
| RIO adapter card connector | HSL_LNK<br>HSL2<br>HSL2_xx<br>HSLH<br>HSLH_xx | Un-CB1-C10-00 | Part number catalog                                                         | Exchanging RIO cables                                                         |
| RIO adapter card connector | HSL_LNK<br>HSL2<br>HSL2_xx<br>HSLH<br>HSLH_xx | Un-CB1-C10-01 | Part number catalog                                                         | Exchanging RIO cables                                                         |

**Notes:**

1. Card positions C01, C05, and C11 are required to be I/O processors.
2. J11 is an RPO connection, J14 is a uninterruptible power supply connector, J15 is an SPCN 1 connector, and J16 is an SPCN 2 connector.
3. Multi-adapter bridge domains are labeled PCI Bridge Set inside the I/O unit.
4. The following table provides information necessary to identify the IOP to which IOAs are assigned.
  - ◆ The left column indicates the domain in which IOA assignment is allowed.
  - ◆ The right column is used to determine the IOP to which an IOA is assigned.
  - ◆ The first position in the list must be an IOP. The remaining positions may be IOPs or IOAs. IOAs are assigned to the first IOP located to their left in the list. Although IOAs can be manually reassigned using SST/DST, the IOA assignments return to the default order after each IPL.

Table 2. Identify the IOP to which IOAs are assigned

| Multi-adapter bridge domain / PCI bridge set | IOA assignment rules    |
|----------------------------------------------|-------------------------|
| C01 - C04                                    | C01, C02, C03, C04      |
| C05 - C09                                    | C05, C06, C07, C08, C09 |
| C11 - C15                                    | C11, C12, C13, C14, C15 |

Parent topic: [Finding part locations](#)

---

## Exchanging the tower card in the 50/88 and 05/88 expansion units

Use this procedure in conjunction with [Powering off an expansion unit](#) to remove or replace the tower card (CB1) in the 50/88 and 05/88 expansion units.

1. Power off the expansion unit (see [Powering off an expansion unit](#)).
2. Open the rear cover (see [Exchanging the covers in the 50/88 and 05/88 expansion units](#)).
3. Remove the ac power cord from the expansion unit.
4. From the rear of the expansion unit, remove the external cables from the rear of the PCI card enclosure and note their locations.
5. Remove the airflow baffle that is located directly above the PCI card enclosure. Loosen the three fasteners and slide the airflow baffle out the back side.
6. Remove the cables from the front of the PCI card assembly and note their locations.

**Attention:** All cards are sensitive to electrostatic discharge (see [Working with electrostatic discharge-sensitive parts](#)).

7. Remove the screws that hold the PCI card enclosure to the frame.
8. Pull the PCI card enclosure out of the frame while lifting the cables clear of the enclosure.
9. Remove the PCI cards from the enclosure and note their locations (see [Exchanging cards \(dedicated\) in the 50/88 and 05/88 expansion units](#)).
10. Remove the HSL/RIO I/O bridge adapter from the enclosure and note its location.
11. Install the new PCI card enclosure by reversing the above procedure.
12. Reconnect the power cord(s) and/or the power supply cords that you disconnected earlier.

**Note:** The expansion unit will power on automatically.

13. Perform [Setting expansion unit configuration ID and MTMS value](#) and then continue with the next step of this procedure.
14. Go to [Verifying the repair](#). This ends the procedure.

Parent topic: [Removing and replacing parts in the 50/88 and 05/88 expansion units](#)

---

## Exchanging cards (concurrent) in the 50/88 and 05/88 expansion units

Use this procedure to remove or replace cards concurrently in the 50/88 and 05/88 expansion units.

### Concurrent/dedicated guidelines

In some cases, you do not need to power down the system to change PCI cards. If you choose to power down the expansion unit, see [Exchanging cards \(dedicated\) in the 50/88 and 05/88 expansion units](#). If you use concurrent maintenance on a partitioned system, follow the procedures from the partition that owns the resource. If the resource is not owned, follow the procedure from the primary partition.

**For 50/88 and 05/88 IXS cards:**

The IXS cards require dedicated maintenance, see [Exchanging cards \(dedicated\) in the 50/88 and 05/88 expansion units](#).

**For 50/88 and 05/88 cards - except IXS cards:**

- Card positions C01 through C09 and C11 through C15 permit card level concurrent maintenance using HSM. You can power down the individual card slot.
- If the resource is the load source IOA or the load source IOP, or any other storage IOA/IOP with critical DASD attached for the system, primary, or secondary partition, follow the on-screen instructions when you use HSM to power down the IOP or IOA. Instructions to use functions 68 and 69 on the control panel will be included.
- If the resource is the console IOA or the console IOP for the system or primary partition, you cannot power down the domain.
- If the resource is the console IOA or the console IOP for a secondary partition, then power down the secondary partition and follow the procedure from the primary partition.

**CAUTION:** Some laser products contain an embedded Class 3A or Class 3B laser diode. Note the following information: laser radiation when open. Do not stare into the beam, do not view directly with optical instruments, and avoid direct exposure to the beam. (C030)

**Attention:** If removing the cover while powered on, errors may occur due to electromagnetic interference.

**Attention:** All cards are sensitive to electrostatic discharge (see [Working with electrostatic discharge-sensitive parts](#)).

1. From the Hardware Service Manager display, select Packaging hardware resources > Hardware contained in packaging for the frame ID that you are working on.
2. Find the card position for the IOA or IOP that you are removing and select Concurrent maintenance.

**Attention:** If multiple resources are shown with the same card position, one or more of these resources will show a status of *Missing* ("?" after the description). Only one resource will be listed as not missing. Select this resource for the concurrent maintenance operation.

3. A listing of the power domain is shown. Find the IOA or IOP that you are removing and select Power off domain. Everything within the IOA's or IOP's power domain will be powered off .
4. To see the status of the power domain, select Display power status.
5. Find the IOA or IOP that you are removing and select Toggle LED blink off/on.
6. Remove the cover to access the card that you are removing from the system (see [Exchanging the covers in the 50/88 and 05/88 expansion units](#)).
7. Look at the power LED for the card that you are removing to ensure that it is powered off. The power LED is located above or in front of the card slot. If the LED is blinking multiple times per second (rapidly) or it is off, then the card is powered off.
8. Remove the rear cover (see [Exchanging the covers in the 50/88 and 05/88 expansion units](#)).
9. Remove the EMC access plate, that is located directly above the card enclosure, by removing the three thumbscrews and pulling the access plate towards you.
10. Disconnect and label any cables from the card that you wish to remove.
11. Turn the latch counterclockwise and lift up on the black latch to release the card.
12. Remove the card by gently pulling it out.

13. Install the card in to the system by reversing the card removal procedure.
14. Select Power on domain for the IOA or IOP that you are installing.

**Note:** To the right of the description field you will see one or both of the following symbols displayed:

- ◆ \* indicates the location to which the system will assign the resource.
- ◆ > indicates the location to which the resource was last assigned.

15. Press Enter. The Work with Controlling Resources display will appear.
16. Determine the location where you want to assign the resource and select Assign to for that location.
17. Wait for the Hardware Resource Concurrent Maintenance display to appear with the message indicating power on complete.
18. After exchanging the failing item, go to [Verifying the repair](#).
19. If you have exchanged a 2766, 2787, or 280E Fibre Channel IOA, the external storage subsystem must be updated to use the world-wide port name of the new IOA. Refer to [Updating the world-wide port name for a new 2766 or 2787 IOA](#) for details. This ends the procedure.

**Parent topic:** [Removing and replacing parts in the 50/88 and 05/88 expansion units](#)

## Part assembly diagrams for , 05/88, 50/79, 50/88, and 52/94 expansion units

### Cover assembly for and 50/79 expansion units

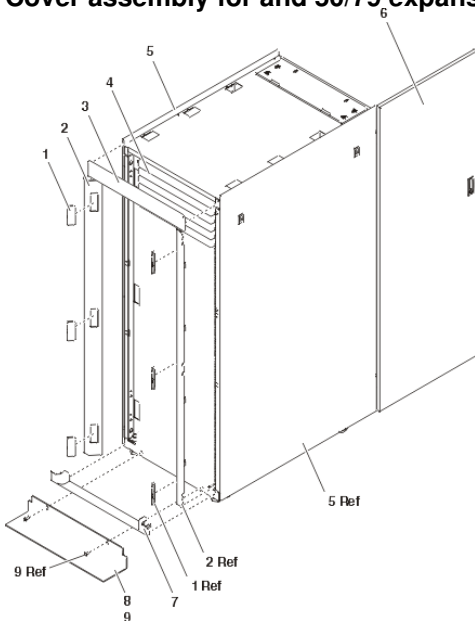


Table 1. Cover assembly part numbers for 05/88 and 50/79 expansion units

| Index | Part number | Units | Description             |
|-------|-------------|-------|-------------------------|
| 1     | 05N6809     | 6     | Cover, trim kit         |
| 2     | 12K0034     | 2     | Side bezel, trim kit    |
| 3     | 12K0032     | 1     | Top bezel, trim kit     |
| 4     | 97H9754     | AR    | 1 high black EIA filler |
| 4     | 97H9755     | AR    | 3 high black EIA filler |
| 4     | 97H9756     | AR    | 5 high black EIA filler |
| 5     | 05N6478     | 2     | Cover, side             |

Service provider information

|   |         |   |                        |
|---|---------|---|------------------------|
| 6 | 31L7523 | 1 | Cover, Back            |
| 7 | 12K0024 | 1 | Bottom bezel, trim kit |
| 8 | 31L8305 | 1 | Tip plate              |
| 9 | 24L0558 | 1 | Screw M8x25            |

**Cover assembly for 50/88 expansion unit**

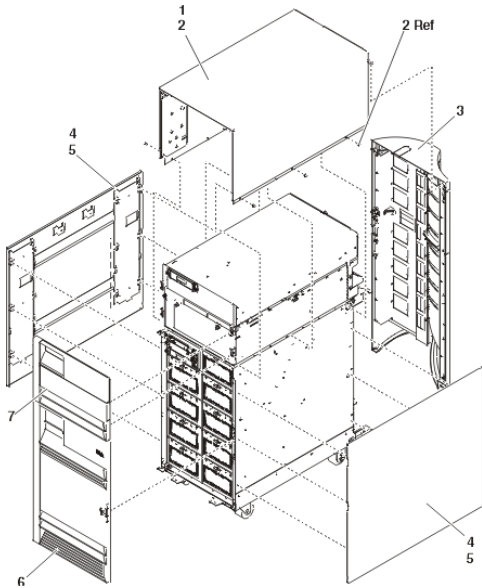


Table 2. Cover assembly part numbers for 50/88 expansion unit

| Index | Part number | Units | Description        |
|-------|-------------|-------|--------------------|
| 1     | 21P4986     | 1     | Top cover          |
| 2     | 1621811     | 6     | Screw, M4 (10mm)   |
| 3     | 44L0247     | 1     | Back cover         |
| 4     | 39J4313     | 2     | Side cover         |
| 5     | 1621811     | 16    | Screw, M4 (10mm)   |
| 6     | 24L1069     | 1     | Front cover, lower |
| 7     | 44L0252     | 1     | Front cover, upper |

**Final assembly for 50/88 expansion unit**

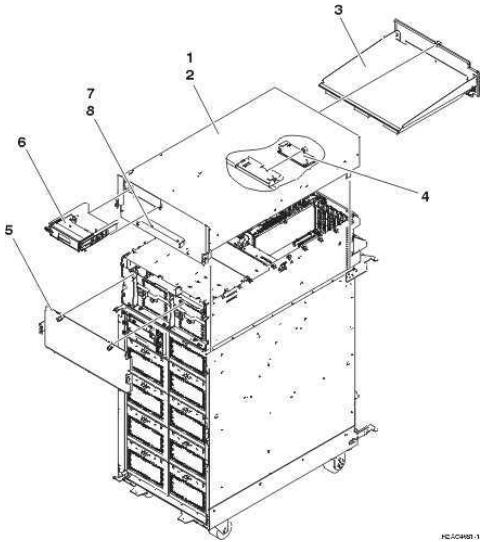


Table 3. Final assembly part numbers for 50/88 expansion unit

| Index | Part number | Units | Description                          |
|-------|-------------|-------|--------------------------------------|
| 1     | 04N4523     | 1     | Top wrap assembly                    |
| 2     | 00G1268     | 4     | Screws, M4X                          |
| 3     | 04N4499     | 1     | Back EMC shield                      |
| 4     | 11K1107     | 1     | Air-moving device (AMD) control card |
| 5     | 04N4500     | 1     | Front EMC shield                     |
| 6     | 24L0962     | 1     | Display panel assembly               |
| 8     | 00G1268     | 2     | Screws, M4X                          |

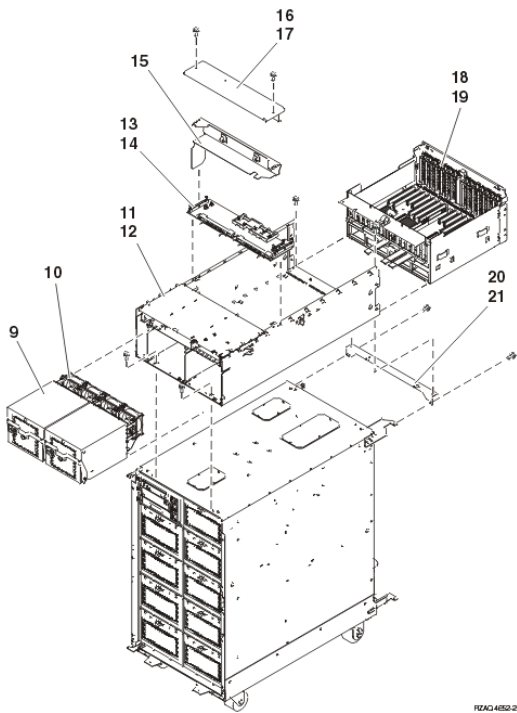


Table 4. Final assembly part numbers for 50/88 expansion unit

| Index | Part number | Units | Description     |
|-------|-------------|-------|-----------------|
| 9     | 00P3918     | 2     | AC power supply |



|    |         |    |                               |
|----|---------|----|-------------------------------|
| 10 | 41L5448 | 2  | Air-moving device             |
| 11 | 21P4894 | 1  | Chassis                       |
| 12 | 1621811 | 6  | Screw, M4 (10mm)              |
| 13 | 00P2382 | 1  | Power distribution            |
| 14 | 00G1268 | 6  | Screws, M4X                   |
| 15 | 44K0243 | 1  | Cable tray                    |
| 16 | 41L5206 | 1  | Cover                         |
| 17 | 00G1268 | 2  | Screw, M4X                    |
| 18 | 53P2354 | AR | PCI node board assembly       |
| 19 | 00G1268 | 6  | Screw, M4X                    |
| 20 | 04N4498 | 1  | Mounting bracket              |
| 21 | 1621811 | 2  | Screw, M4 (10mm)              |
| NA | 04N3038 | AR | Power supply to PDU line cord |
| NA | 21P6094 | AR | Miscellaneous power cable     |
| NA | 41L5650 | AR | SPCN cable                    |
| NA | 41L5649 | AR | Display panel cable           |
| NA | 41L5652 | AR | Fan control cable             |

**Optional hardware assembly for 50/79, and 52/94 expansion units**

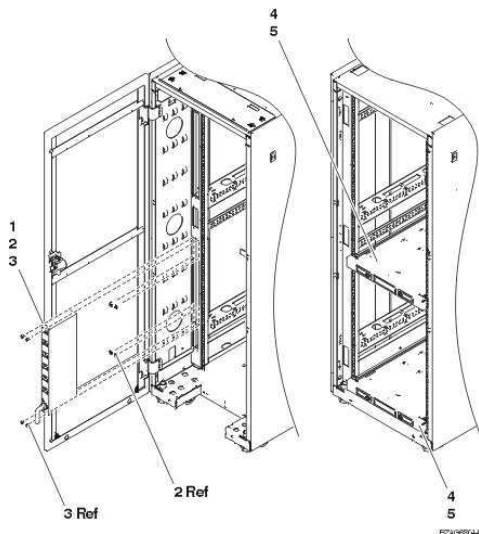


Table 5. Optional hardware assembly part numbers for 50/79, and 52/94 expansion units

| Index | Part number | Units | Description                                             |
|-------|-------------|-------|---------------------------------------------------------|
| 1     | 00P2200     | 1     | Type 6 power distribution unit single phase U.S.        |
|       | 00P2201     | 1     | Type 6 power distribution unit two phase                |
|       | 00P2202     | 1     | Type 6 power distribution unit three phase              |
|       | 00P2203     | 1     | Type 6 power distribution unit single phase World Trade |
|       | 00P3663     | 1     | Type 7 Power distribution panel (1 Phase)               |
|       | 00P3665     | 1     | Type 7 Power distribution panel (1 Phase World Trade)   |
|       | 00P3667     | 1     | Type 7 Power distribution panel (3 Phase World          |

Service provider information

|   |         |    | Trade)   |
|---|---------|----|----------|
| 2 | 74F1823 | 4  | Nut clip |
| 3 | 1624779 | 4  | Screw    |
| 5 | 1624779 | 16 | Screw    |

Parent topic: [Part assembly diagrams](#)

---

## Exchanging the power distribution board in the 50/88 and 05/88 expansion units

Use this procedure to remove or replace the power distribution board (PB1) in the 50/88 and 05/88 expansion units.

1. Remove the top, front, and rear covers (see [Exchanging the covers in the 50/88 and 05/88 expansion units](#)).
2. Power off the expansion unit (see [Powering off an expansion unit](#)). Pull the power plugs that run from the unit to the ac box of the lower unit.
3. Remove the center top plate.
4. Remove the two power supplies (see [Exchanging the power supplies in the 50/88 and 05/88 expansion units](#)).
5. From the top of the unit, remove and label the cables that connect to the power distribution board.
6. Remove the screws that secure the power distribution board to the expansion unit.
7. Pull the power distribution board out through the top of the expansion unit.
8. Install the new power distribution backplane by reversing this procedure.
9. After exchanging an item, go to [Verifying the repair](#). This ends the procedure.

Parent topic: [Removing and replacing parts in the 50/88 and 05/88 expansion units](#)

---

## Exchanging the power supplies in the 50/88 and 05/88 expansion units

Use this procedure to remove or replace the power supplies (P01 and P02) in the 50/88 and 05/88 expansion units.

**Note:** Remove and replace only one power supply at a time.

**Attention:** Do not power off the system if it is powered on. This procedure can be performed concurrently.

1. Open the front cover (see [Exchanging the covers in the 50/88 and 05/88 expansion units](#)).
2. Remove the ac line cord from the power supply being replaced.
3. Pull down on the docking handle located in the front of the power supply, to release the power supply from the expansion unit.
4. Remove the power supply.
5. Remove the air moving device (AMD) from the power supply by pulling out on the latch knob and sliding the AMD to the left (towards the latch).
6. Install the new power supply by reversing this procedure.

**Attention:** Do not use excessive force when installing the new power supply into the system. Insert the power supply until it engages the frame, then lift the docking handle to lock the power supply into place.

7. After exchanging an item, go to [Verifying the repair](#). This ends the procedure.

**Parent topic:** [Removing and replacing parts in the 50/88 and 05/88 expansion units](#)

---

## Exchanging the air-moving device (AMD) in the 50/88 and 05/88 expansion units

Use this procedure to remove or replace the air-moving device (AMD) (B01 and B02) in the 50/88 and 05/88 expansion units.

**Attention:** Since this procedure can be performed concurrently, you do not need to power off the unit if it is already powered on.

1. Remove the front cover (see [Exchanging the covers in the 50/88 and 05/88 expansion units](#)).
2. Remove the upper EMC access plate.
3. Remove the ac line cord from the power supply attached to the AMD being replaced.
4. Remove the power supply that has the defective AMD attached by pulling down on the docking handle, and sliding the power supply with the two AMDs attached out of the expansion unit.
5. Remove the AMD from the power supply by pulling out on the latch knob and sliding the AMD to the left towards the latch.
6. Install the new AMD by reversing this removal procedure.

**Attention:** Do not use excessive force when installing the new power supply into the system. Insert the power supply until it engages the frame, then lift the docking handle to lock the power supply into place.

7. After exchanging an item, go to [Verifying the repair](#). This ends the procedure.

**Parent topic:** [Removing and replacing parts in the 50/88 and 05/88 expansion units](#)

## Exchanging the AMD controller card in the 50/88 and 05/88 expansion units

Use this procedure to remove or replace the air moving device (AMD) controller card (BB1) in the 50/88 and 05/88 expansion units.

1. Power off the PCI expansion unit (see [Powering off an expansion unit](#)).
2. Disconnect the two ac power cords from the ac box.
3. Remove the rear cover (see [Exchanging the covers in the 50/88 and 05/88 expansion units](#)).
4. Remove the EMC access plate over the card enclosure by loosening the thumbscrews and pulling it toward you.
5. Unclip and remove the cable by pressing down on the cable retainers to eject it.
6. Remove the AMD controller card by pulling out on the latch knob and sliding the card back toward you.
7. Install the new AMD controller card by reversing this removal procedure. After exchanging an item, go to [Verifying the repair](#). This ends the procedure.

**Parent topic:** [Removing and replacing parts in the 50/88 and 05/88 expansion units](#)

---

## Exchanging the control panel in the 50/88 and 05/88 expansion units

Use this procedure to remove or replace the control panel (NB1) in the 50/88 and 05/88 expansion units.

**CAUTION:**The system contains circuit cards, assemblies, or both that contain lead solder. To avoid the release of lead (Pb) into the environment, do not burn. Discard the circuit card as instructed by local regulations. (C014)

**Attention:** The control panel is sensitive to electrostatic discharge (see [Working with electrostatic discharge-sensitive parts](#)).

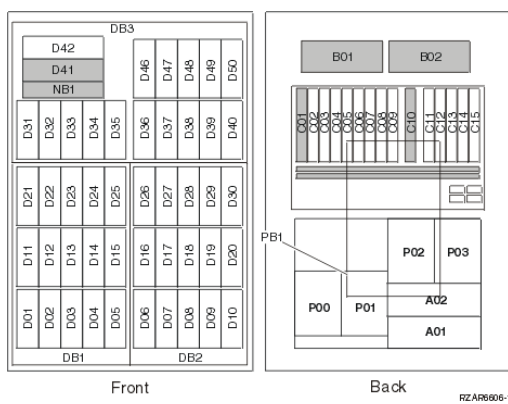
1. Power down the expansion unit (see [Powering off an expansion unit](#)). Pull the power plugs that run from the expansion unit to the AC box of the unit below.
2. Open the front cover (see [Exchanging the covers in the 50/88 and 05/88 expansion units](#)).
3. Pull on the two side fasteners to release the control panel assembly.
4. Slide the panel partially out of the unit.
5. Disconnect the cables that are attached to back side of the control panel.
6. Remove the control panel from the unit.
7. Install the new control panel by reversing this procedure. After exchanging an item, go to [Verifying the repair](#). This ends the procedure.

Parent topic: [Removing and replacing parts in the 50/88 and 05/88 expansion units](#)

## Locations 50/94, 52/94, 8094-002, 82/94, and 91/94 expansion unit

**Note:** The known logical location codes for this unit are listed next to the corresponding physical location in the following information. If you are working with a logical location code for this unit and it is not listed in the following information, contact your next level of support.

The following diagram shows FRU layout in the 50/94 expansion unit. Use it with the following tables.



**Note:** Do not install power supplies P00 and P01 ac jumper cables on the same ac module.

The following table gives the components available for callout on the 50/94, 52/94, 8094-002, 82/94, and 91/94 expansion units. It matches those components with the FRU containing the component. The other columns give location information, a link to a removal and replacement procedure, and additional comments.

**Attention:** After replacing any part on a server or expansion unit, perform [Verifying the repair](#).

Table 1. FRU locations and failing components for 50/94, 52/94, 8094-002, 82/94, and 91/94 expansion units

| Failing item name                                                                                                           | Symbolic FRU name                                                                              | Physical location code | Link to part number  | Failing item removal and replacement procedures                                 |
|-----------------------------------------------------------------------------------------------------------------------------|------------------------------------------------------------------------------------------------|------------------------|----------------------|---------------------------------------------------------------------------------|
| Expansion unit backplane<br><ul style="list-style-type: none"> <li>• SPCN</li> <li>• Card enclosure or backplane</li> </ul> | TWRCARD<br>MA_BRDG<br>MABRCFG<br>PPCITWR<br>PRI_PCI<br>HSL_LNK<br>PIOCARD<br>MASBUS<br>TWRBKPL | Un-CB1                 | <a href="#">28B7</a> | <a href="#">Exchanging the backplane in the 50/94 and 82/94 expansion units</a> |

|                                                                                                                     |                              |                                                      |                     |                                                                                                          |                  |                                                        |
|---------------------------------------------------------------------------------------------------------------------|------------------------------|------------------------------------------------------|---------------------|----------------------------------------------------------------------------------------------------------|------------------|--------------------------------------------------------|
| <ul style="list-style-type: none"> <li>Multi-adapter bridge (all)</li> </ul>                                        | PIOCARD<br>MASBUS<br>SLOTERR | Un-CB1-C01                                           |                     |                                                                                                          |                  |                                                        |
| PCI adapter in slot 1                                                                                               | PIOCARD<br>MASBUS<br>SLOTERR | Un-CB1-C02                                           |                     |                                                                                                          |                  |                                                        |
| PCI adapter in slot 2                                                                                               | PIOCARD<br>MASBUS<br>SLOTERR | Un-CB1-C03                                           |                     |                                                                                                          |                  |                                                        |
| PCI adapter in slot 3                                                                                               | PIOCARD<br>MASBUS<br>SLOTERR | Un-CB1-C04                                           |                     |                                                                                                          |                  |                                                        |
| PCI adapter in slot 4                                                                                               | PIOCARD<br>MASBUS<br>SLOTERR | Un-CB1-C05                                           | Part number catalog | PCI adapter in the <a href="#">Installing hardware</a> topic.                                            |                  |                                                        |
| PCI adapter in slot 5                                                                                               | PIOCARD<br>MASBUS<br>SLOTERR | Un-CB1-C06                                           |                     |                                                                                                          |                  |                                                        |
| PCI adapter in slot 6                                                                                               | PIOCARD<br>MASBUS<br>SLOTERR | Un-CB1-C07                                           |                     |                                                                                                          |                  |                                                        |
| PCI adapter in slot 7                                                                                               | PIOCARD<br>MASBUS<br>SLOTERR | Un-CB1-C08                                           |                     |                                                                                                          |                  |                                                        |
| PCI adapter in slot 8                                                                                               | PIOCARD<br>MASBUS<br>SLOTERR | Un-CB1-C09                                           |                     |                                                                                                          |                  |                                                        |
| PCI adapter in slot 9                                                                                               | PIOCARD<br>MASBUS<br>SLOTERR |                                                      |                     |                                                                                                          |                  |                                                        |
| RIO adapter card <ul style="list-style-type: none"> <li>HSL I/O adapter</li> <li>PCI host bridge adapter</li> </ul> | SIIOADP<br>SIADPCD<br>SI_PHB | Un-CB1-C10                                           |                     |                                                                                                          | 2886, 2887, 28E7 | FC 5074, FC 5079, FC 5094, FC 5294 - Cards (dedicated) |
| PCI adapter in slot 11                                                                                              | PIOCARD<br>MASBUS<br>SLOTERR | Un-CB1-C11                                           |                     |                                                                                                          |                  |                                                        |
| PCI adapter in slot 12                                                                                              | PIOCARD<br>MASBUS<br>SLOTERR | Un-CB1-C12                                           |                     |                                                                                                          |                  |                                                        |
| PCI adapter in slot 13                                                                                              | PIOCARD<br>MASBUS<br>SLOTERR | Un-CB1-C13                                           | Part number catalog | PCI adapter in the <a href="#">Installing hardware</a> topic.                                            |                  |                                                        |
| PCI adapter in slot 14                                                                                              | PIOCARD<br>MASBUS<br>SLOTERR | Un-CB1-C14                                           |                     |                                                                                                          |                  |                                                        |
| PCI adapter in slot 15                                                                                              | PIOCARD<br>MASBUS<br>SLOTERR | Un-CB1-C15                                           |                     |                                                                                                          |                  |                                                        |
| PCI bridge set 1                                                                                                    | BRDGSET<br>BRDGST1           | Un-CB1-C01<br>Un-CB1-C02<br>Un-CB1-C03<br>Un-CB1-C04 |                     |                                                                                                          |                  |                                                        |
| PCI bridge set 2                                                                                                    | BRDGSET<br>BRDGST2           | Un-CB1-C05<br>Un-CB1-C06                             |                     | Replace the cards using the removal and replacement procedures corresponding to the locations indicated. |                  |                                                        |

Service provider information

|                                           |                    |                                                                    |                                                                           |                                                                                                                                                                  |
|-------------------------------------------|--------------------|--------------------------------------------------------------------|---------------------------------------------------------------------------|------------------------------------------------------------------------------------------------------------------------------------------------------------------|
|                                           |                    | Un-CB1-C07<br>Un-CB1-C08<br>Un-CB1-C09                             |                                                                           |                                                                                                                                                                  |
| PCI bridge set 3                          | BRDGSET<br>BRDGST3 | Un-CB1-C11<br>Un-CB1-C12<br>Un-CB1-C13<br>Un-CB1-C14<br>Un-CB1-C15 |                                                                           |                                                                                                                                                                  |
| Fan 1                                     |                    | Un-B01                                                             | Part assembly diagrams for 50/74, 50/94, 82/94, and 91/94 expansion units | Exchanging air moving devices in the 50/94 and 82/94 expansion units                                                                                             |
| Fan 2                                     |                    | Un-B02                                                             |                                                                           |                                                                                                                                                                  |
| Power board                               |                    | Un-PB1                                                             | Part assembly diagrams for 50/74, 50/94, 82/94, and 91/94 expansion units | Exchanging the power distribution backplane in the 50/94 and 82/94 expansion units                                                                               |
| AC module 1                               |                    | Un-A01                                                             | Power parts                                                               | Exchanging ac modules in the 50/94 and 82/94 expansion units (single line cord) or Exchanging ac modules in the 50/94 and 82/94 expansion units (dual line cord) |
| AC module 2                               |                    | Un-A02                                                             |                                                                           |                                                                                                                                                                  |
| Power supply 0 (dual line cord only)      |                    | Un-P00                                                             | Part assembly diagrams for 50/74, 50/94, 82/94, and 91/94 expansion units | Exchanging power supplies in the 50/94 and 82/94 expansion units                                                                                                 |
| Power supply 1 (single or dual line cord) |                    | Un-P01                                                             |                                                                           |                                                                                                                                                                  |
| Power supply 2 (single or dual line cord) |                    | Un-P02                                                             |                                                                           |                                                                                                                                                                  |
| Power supply 3 (single or dual line cord) |                    | Un-P03                                                             |                                                                           |                                                                                                                                                                  |
| Device board 1                            |                    | Un-DB1                                                             | 28CC                                                                      | Exchanging device boards (DB1 and DB2) in the 50/94 and 82/94 expansion units                                                                                    |
| Device board 2                            |                    | Un-DB2                                                             |                                                                           |                                                                                                                                                                  |
| Device board 3                            |                    | Un-DB3                                                             | 28CB                                                                      | Exchanging device board (DB3) in the 50/94 and 82/94 expansion units                                                                                             |
| Display panel                             |                    | Un-NB1                                                             | 247B                                                                      | Exchanging the control panel in the 50/94 and 82/94 expansion units                                                                                              |
| Disk units 1 5                            |                    | Un-DB1-D01<br>Un-DB1-D02<br>Un-DB1-D03<br>Un-DB1-D04<br>Un-DB1-D05 | Part number catalog                                                       | Disk unit recovery procedures                                                                                                                                    |
| Disk units 6 10                           |                    | Un-DB2-D06<br>Un-DB2-D07<br>Un-DB2-D08<br>Un-DB2-D09<br>Un-DB2-D10 | Part number catalog                                                       | Disk unit recovery procedures                                                                                                                                    |
| Disk units 11 15                          |                    | Un-DB1-D11<br>Un-DB1-D12<br>Un-DB1-D13<br>Un-DB1-D14               | Part number catalog                                                       | Disk unit recovery procedures                                                                                                                                    |

Service provider information

|                                      |                                               |                                                                                                                                          |                        |                                                                           |
|--------------------------------------|-----------------------------------------------|------------------------------------------------------------------------------------------------------------------------------------------|------------------------|---------------------------------------------------------------------------|
|                                      |                                               | Un-DB1-D15                                                                                                                               |                        |                                                                           |
| Disk units<br>16 20                  |                                               | Un-DB2-D16<br>Un-DB2-D17<br>Un-DB2-D18<br>Un-DB2-D19<br>Un-DB2-D20                                                                       | Part number<br>catalog | Disk unit recovery<br>procedures                                          |
| Disk units<br>21 25                  |                                               | Un-DB1-D21<br>Un-DB1-D22<br>Un-DB1-D23<br>Un-DB1-D24<br>Un-DB1-D25                                                                       | Part number<br>catalog | Disk unit recovery<br>procedures                                          |
| Disk units<br>26 30                  |                                               | Un-DB2-D26<br>Un-DB2-D27<br>Un-DB2-D28<br>Un-DB2-D29<br>Un-DB2-D30                                                                       | Part number<br>catalog | Disk unit recovery<br>procedures                                          |
| Disk units<br>31 40                  |                                               | Un-DB3-D31<br>Un-DB3-D32<br>Un-DB3-D33<br>Un-DB3-D34<br>Un-DB3-D35<br>Un-DB3-D36<br>Un-DB3-D37<br>Un-DB3-D38<br>Un-DB3-D39<br>Un-DB3-D40 | Part number<br>catalog | Disk unit recovery<br>procedures                                          |
| Media (optical)                      |                                               | Un-DB3-D41                                                                                                                               | Part number<br>catalog | Media device in an<br>expansion unit in the<br>Installing hardware topic. |
| Media (tape)                         |                                               | Un-DB3-D42                                                                                                                               |                        |                                                                           |
| Disk units<br>46 50                  |                                               | Un-DB3-D46<br>Un-DB3-D47<br>Un-DB3-D48<br>Un-DB3-D49<br>Un-DB3-D50                                                                       | Part number<br>catalog | Disk unit recovery<br>procedures                                          |
| RIO/HSL<br>adapter card<br>connector | HSL_LNK<br>HSL2<br>HSL2_xx<br>HSLH<br>HSLH_xx | Un-CB1-C10-00                                                                                                                            | Part number<br>catalog | Exchanging RIO cables                                                     |
| RIO/HSL<br>adapter card<br>connector | HSL_LNK<br>HSL2<br>HSL2_xx<br>HSLH<br>HSLH_xx | Un-CB1-C10-01                                                                                                                            |                        |                                                                           |

**Notes:**

- Card positions C01, C05, and C11 are required to be I/O processors.
- J11 is an RPO connection, J14 is an uninterruptible power supply connector, J15 is an SPCN 1 connector, and J16 is an SPCN 2 connector.
- Multi-adapter bridge domains are labeled PCI Bridge Set inside the I/O unit.
- The following table provides information necessary to identify the IOP to which IOAs are assigned.
  - ◆ The left column indicates the domain in which IOA assignment is allowed.
  - ◆ The right column is used to determine the IOP to which an IOA is assigned.
  - ◆ The first position in the list must be an IOP. The remaining positions may be IOPs or IOAs. IOAs are assigned to the first IOP located to their left in the list. Although IOAs can be manually reassigned using SST/DST, the IOA assignments return to the default order after each IPL.

Table 2. Identify the IOP to which IOAs are assigned



| Multi-adapter bridge domain / PCI bridge set | IOA assignment rules    |
|----------------------------------------------|-------------------------|
| C01 - C04                                    | C01, C02, C03, C04      |
| C05 - C09                                    | C05, C06, C07, C08, C09 |
| C11 - C15                                    | C11, C12, C13, C14, C15 |

Parent topic: [Finding part locations](#)

---

## Exchanging the backplane in the 50/94 and 82/94 expansion units

Use this procedure in conjunction with [Powering off an expansion unit](#) to remove or replace the backplane in the 50/94 and 82/94 expansion units.

1. Power off the expansion unit using [Powering off an expansion unit](#).

**Note:** The primary I/O unit backplane cannot be replaced concurrently.

2. Open the rear cover (see [Exchanging the covers in the 50/74, 50/79, 50/94, 52/94, 8079-002, 8093-002, 8094-002, and 82/94 expansion units](#)).
  3. Disconnect the plugs to each power supply.
  4. From the rear of the expansion unit do the following:
    - a. Remove the external cables from the rear of the PCI card enclosure and note their locations.
    - b. Remove the EMC access plate that is located directly above the PCI card enclosure. Press the surfaces of the two latching mechanisms together and tilt the top of the cover away from the frame to remove it.
    - c. Remove the cables from the top of the PCI cards and note their locations.
- Attention:** All cards are sensitive to electrostatic discharge (see [Working with electrostatic discharge-sensitive parts](#)).
- d. Remove the screws that hold the PCI card enclosure to the frame.
  - e. Pull the PCI card enclosure partially out of the frame while lifting the cables clear of the enclosure.
  - f. Press the release mechanism that is located along the top right side of the enclosure and carefully slide the enclosure towards you. Make sure that the cables are clear of the enclosure.
5. Remove the PCI cards from the enclosure and note their locations (see [Exchanging cards \(dedicated\) in the 50/74, 50/79, 50/94, 52/94, 8079-002, 8093-002, 8094-002, and 82/94 expansion units](#)).
  6. Install the new PCI card enclosure by reversing the above procedure. Then continue with the next step.
  7. Reconnect the power cord(s) and/or the power supply cords that you disconnected earlier.

**Note:** The expansion unit will power on automatically.

8. Perform [Setting expansion unit configuration ID and MTMS value](#) and then continue with the next step of this procedure.
9. Go to [Verifying the repair](#). This ends the procedure.

Parent topic: [Removing and replacing parts in the 50/94, 52/94, and 82/94 expansion units](#)

---

## Exchanging air moving devices in the 50/94 and 82/94 expansion units

Use this procedure to remove or replace an air moving device (AMD) (B01 and B02) in the 50/94 and 82/94 expansion units.

**Note:** Since this procedure can be performed concurrently, you do not need to power down the expansion unit if it is powered on.

1. Open the rear cover (see [Exchanging the covers in the 50/74, 50/79, 50/94, 52/94, 8079-002, 8093-002, 8094-002, and 82/94 expansion units](#)).
2. Remove the EMC access plate located directly above the PCI card enclosure. Press the surfaces of the two latches together and tilt the top of the cover away from the rack to remove it.
3. Remove the screw from the AMD door assembly for the AMD that you are replacing.
4. Remove the AMD assembly by sliding it out of the enclosure while holding the AMD access plate open.
5. Install the new AMD by reversing this procedure. The new AMD will automatically power on when it is installed.
6. After exchanging an item, go to [Verifying the repair](#). This ends the procedure.

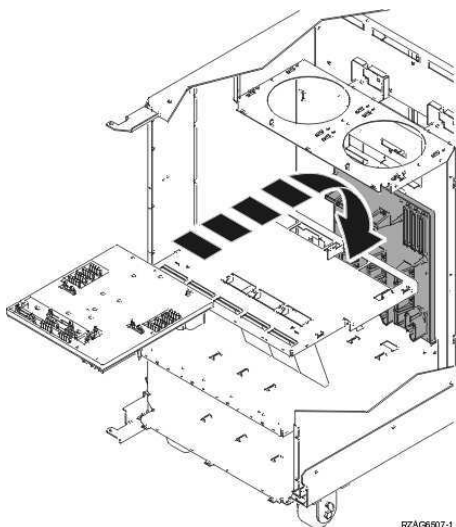
Parent topic: [Removing and replacing parts in the 50/94, 52/94, and 82/94 expansion units](#)

---

## Exchanging the power distribution backplane in the 50/94 and 82/94 expansion units

Use this procedure to remove or replace the power distribution backplane (PB1) in the 50/94 and 82/94 expansion units.

1. You must remove both device boards DB1 and DB2 before continuing with this procedure. Perform [Exchanging device boards \(DB1 and DB2\) in the 50/94 and 82/94 expansion units](#) for each backplane. After you have removed both device boards, return here and continue with the next step of this procedure.
2. Remove the rear cover (see [Exchanging the covers in the 50/74, 50/79, 50/94, 52/94, 8079-002, 8093-002, 8094-002, and 82/94 expansion units](#)).
3. Remove the PCI drawer (see [Exchanging the backplane in the 50/94 and 82/94 expansion units](#)).
4. Remove the ac module (see [Exchanging ac modules in the 50/94 and 82/94 expansion units \(single line cord\)](#) or [Exchanging ac modules in the 50/94 and 82/94 expansion units \(dual line cord\)](#)).
5. Remove all power supplies in the unit you are working on (see [Exchanging power supplies in the 50/94 and 82/94 expansion units](#)).
6. Remove the screws from the power subframe assembly.
7. From the front of the unit, reach through and remove the cables from the backside of the power distribution backplane and note their locations.
8. From the rear of the unit, remove the mounting screws that hold the power distribution backplane to the unit.
9. Pull the power distribution backplane slightly towards you and lift it up to remove it from the unit.



10. Install the new power distribution backplane by reversing this procedure.

**Attention:** Do not install power supplies P00 and P01 ac jumper cables on the same ac input module.

11. After exchanging an item, go to [Verifying the repair](#). This ends the procedure.

**Parent topic:** [Removing and replacing parts in the 50/94, 52/94, and 82/94 expansion units](#)

---

## Exchanging ac modules in the 50/94 and 82/94 expansion units (dual line cord)

Use this procedure to remove or replace an ac module (A01 and A02) in the dual line cord 50/94 and 82/94 expansion units.

**Note:** Since this procedure can be performed concurrently, you do not need to power down the expansion unit if it is powered on.

1. Open the rear cover (see [Exchanging the covers in the 50/74, 50/79, 50/94, 52/94, 8079-002, 8093-002, 8094-002, and 82/94 expansion units](#)).
2. Trace and disconnect the ac input line cord that connects to the ac module that needs replacing (see [Locations 50/94, 52/94, 8094-002, 82/94, and 91/94 expansion unit](#)).

**Attention:** Do not disconnect the other system ac line cord when powered on.

3. Disconnect the power supply jumper cords from the ac module that you are working on.

**Attention:** Do not disconnect the other expansion unit ac module power supply jumper cords.

4. Remove the left and right screws that hold the ac module to the expansion unit.
5. Remove the ac module unit.
6. Install the new ac module by reversing this procedure.

**Note:** Do not install power supplies P00 and P01 ac jumper cables on the same ac input module.

7. After exchanging an item, go to [Verifying the repair](#). This ends the procedure.

**Parent topic:** [Removing and replacing parts in the 50/94, 52/94, and 82/94 expansion units](#)

---

## Exchanging power supplies in the 50/94 and 82/94 expansion units

Use this procedure to remove or replace a power supply (P00, P01, P02, P03) in the 50/94 and 82/94 expansion units.

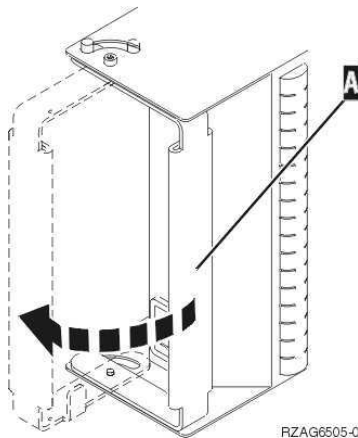
**Note:** Since this procedure can be performed concurrently, you do not need to power down the expansion unit if it is powered on.

1. Open the rear cover (see [Exchanging the covers in the 50/74, 50/79, 50/94, 52/94, 8079-002, 8093-002, 8094-002, and 82/94 expansion units](#)).
2. Disconnect the ac power jumper cord from the unit you are replacing.
3. Remove the bottom screw (if installed).
4. Rotate the handle from right to left to release the power supply.

**CAUTION:**The power distribution outlets provide 200 to 240 V ac. Use these outlets only for devices that operate within this voltage range. (C021)

5. Remove the power supply.

*Figure 1. Removing the power supply - P00, P01, P02, P03*



6. Install the new power supply by reversing this procedure.

**Attention:** Do not forcibly insert the power supply in when installing it. Insert it until the power supply engages the unit, then rotate the handle from left to right.

**Attention:** Do not install power supplies P00 and P01 ac jumper cables on the same ac input module.

7. After exchanging an item, go to [Verifying the repair](#). This ends the procedure.

**Parent topic:** [Removing and replacing parts in the 50/94, 52/94, and 82/94 expansion units](#)

## Exchanging device boards (DB1 and DB2) in the 50/94 and 82/94 expansion units

Use this procedure to remove or replace a device board (DB1 and DB2) in the 50/94 and 82/94 expansion units.

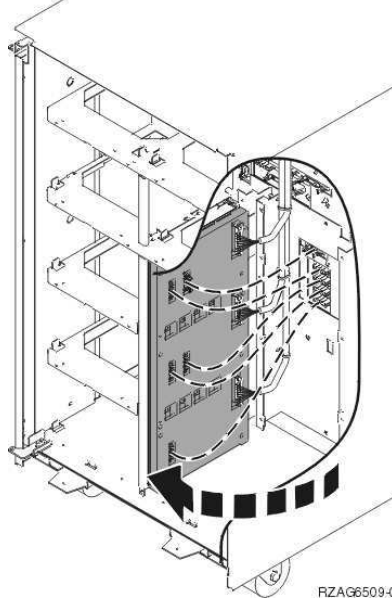
1. Power off the expansion unit (see [Powering off an expansion unit](#)).
2. Disconnect the power cord from the expansion unit.
3. Open the front cover (see [Exchanging the covers in the 50/74, 50/79, 50/94, 52/94, 8079-002, 8093-002, 8094-002, and 82/94 expansion units](#)).
4. From the front of the expansion unit, perform the following:
  - a. Remove the EMC access plates from the disk unit enclosures that are located in front of the board that you are replacing (see [Locations 50/94, 52/94, 8094-002, 82/94, and 91/94 expansion unit](#)). Press the surfaces of the two latching mechanisms together and tilt the top of the cover away from the frame to remove it.
  - b. Record the locations of the disk units and then remove them from the disk unit enclosures that you just uncovered.

**Attention:** The disk units are sensitive to electrostatic discharge (see [Working with electrostatic discharge-sensitive parts](#)).

- c. Remove the screws that hold the disk unit cage assembly to the frame.
  - d. Remove the two retaining screws that are located inside of the disk unit cage assembly (the top right and bottom left corners).
  - e. Remove the disk unit cage assemblies.
  - f. Remove the screws that hold the DASD shelf to the frame.
  - g. Remove the DASD shelf from the frame.
5. Remove the retaining screw that is holding the device board assembly to the frame.
  6. Pull the device board assembly out until it slides off the guide pins, then rotate the device board assembly 90 degrees. Note the locations of the cables that are located on the backside of the board assembly, and then remove the cables.

**Note:** Both ends of the ribbon cables are marked LH or RH, indicating that one end of the cable is plugged in to either the left-hand (DB1) or right-hand (DB2) device board assembly. The other end of the cable is plugged in to either the left-most (LH) or right-most (RH) DASD controller card. The cables will cross in the center of the tower.

Figure 1. Device board cabling



7. Remove the device board assembly.
8. Install the new device board assembly by reversing this remove procedure.
9. After exchanging an item, go to [Verifying the repair](#). This ends the procedure.

**Parent topic:** [Removing and replacing parts in the 50/94, 52/94, and 82/94 expansion units](#)

## Exchanging device board (DB3) in the 50/94 and 82/94 expansion units

Use this procedure to remove or replace a device board (DB3) in the 50/94 and 82/94 expansion units.

1. Power off the expansion unit (see [Powering off an expansion unit](#)).
2. Disconnect the power cord from the expansion unit.
3. Open the rear cover (see [Exchanging the covers in the 50/74, 50/79, 50/94, 52/94, 8079-002, 8093-002, 8094-002, and 82/94 expansion units](#)).
4. From the rear of the expansion unit do the following:
  - a. Remove the EMC access plate that is located directly above the tower card enclosure. Press the surfaces of the two latching mechanisms together and tilt the top of the cover away from

the frame to remove it.

- b. Remove the cables from the disk unit controller cards (IOAs) that are located inside the PCI card enclosure and note their locations.

**Note:** Both ends of the ribbon cables are marked LH or RH, indicating that one end of the cable is plugged in to either the left-hand (DB1) or right-hand (DB2) DASD board assembly. The other end of the cable is plugged in to either the left-most (LH) or right-most (RH) DASD controller card. The cables will cross in the center of the tower.

- c. Remove the screws that hold the tower card enclosure to the frame.
  - d. Pull the tower card enclosure partially out of the frame while lifting the cables clear of the enclosure.
  - e. Press the release mechanism that is located along the top right side of the enclosure and carefully slide the enclosure towards you. Make sure that the cables are clear of the enclosure.
  - f. Remove the tower card enclosure from the frame.
  - g. Remove the screws from the EMC access plate that is located inside the frame and directly above the power distribution board.
  - h. Remove the EMC access plate.
  - i. Reach through the opening and remove the cables from the backside of the base device board assembly (DB3).
5. Open the front cover (see [Exchanging the covers in the 50/74, 50/79, 50/94, 52/94, 8079-002, 8093-002, 8094-002, and 82/94 expansion units](#)).
  6. From the front of the expansion unit do the following:
    - a. Note the removable media locations and then remove them by pulling out on the handles that are located on each side of the unit.
    - b. Remove the control panel by pulling on the handles that are located on each side of the unit and sliding it partially out of the unit. Then, unplug the cable from the rear of the control panel (see [Exchanging the control panel in the 50/94 and 82/94 expansion units](#)).
    - c. Unplug the control panel cable from the base device board assembly (DB3).
    - d. Remove the two retaining screws that are located inside of the removable media enclosure (the top right and lower left corners).
    - e. Remove the removable media enclosure.
    - f. Remove the EMC access plates from the disk unit enclosures that are located in front of the device board (DB3) (see [Locations 50/94, 52/94, 8094-002, 82/94, and 91/94 expansion unit](#)). Press the surfaces of the two latching mechanisms together and tilt the top of the cover away from the frame to remove it.
    - g. Record the disk unit locations and then remove them from the disk unit enclosures that you just uncovered.

**Attention:** The disk units are sensitive to electrostatic discharge (see [Working with electrostatic discharge-sensitive parts](#)).

- h. Remove the screws that hold the disk unit enclosures to the frame.
  - i. Remove the retaining screws that are located inside the disk unit enclosure.
  - j. Remove the disk unit enclosures.
  - k. Remove the screws that hold the center support bracket and shelf for the disk unit and removable media enclosure to the frame.
  - l. Remove the support bracket and shelf.
  - m. Remove the base device board assembly (DB3).
7. Install the new base device board assembly by reversing this removal procedure.
  8. After exchanging an item, go to [Verifying the repair](#). This ends the procedure.

**Parent topic:** [Removing and replacing parts in the 50/94, 52/94, and 82/94 expansion units](#)

---

## Exchanging the control panel in the 50/94 and 82/94 expansion units

Use this procedure to remove or replace the control panel (NB1) in the 50/94 and 82/94 expansion units.

**Attention:** The control panel is sensitive to electrostatic discharge (see [Working with electrostatic discharge-sensitive parts](#)).

1. Power off the expansion unit (see [Powering off an expansion unit](#)).
2. Disconnect the ac power cord from the expansion unit. Note that dual line cord units have two power cords.
3. Open the front cover (see [Exchanging the covers in the 50/74, 50/79, 50/94, 52/94, 8079-002, 8093-002, 8094-002, and 82/94 expansion units](#)).
4. Pull on the two side fasteners to release the control panel assembly.
5. Slide the panel partially out of the frame.
6. Disconnect the cables that are attached to the backside of the control panel.
7. Remove the control panel from the frame.
8. Reverse the above procedure to install the new panel.
9. After exchanging an item, go to [Verifying the repair](#). This ends the procedure.

**Parent topic:** [Removing and replacing parts in the 50/94, 52/94, and 82/94 expansion units](#)

## Locations 05/95 and 50/95 expansion units

**Note:** The known logical location codes for this unit are listed next to the corresponding physical location in the following information. If you are working with a logical location code for this unit and it is not listed in the following information, contact your next level of support.

The following diagrams show field replaceable unit (FRU) layout in the 05/95 and 50/95 expansion units. Use them with the following tables.

Figure 1. 50/95 expansion unit

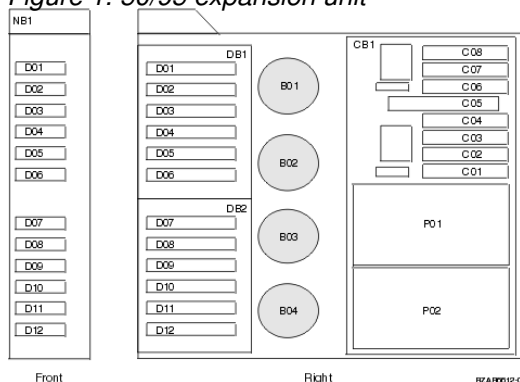




Figure 2. 05/95 expansion unit

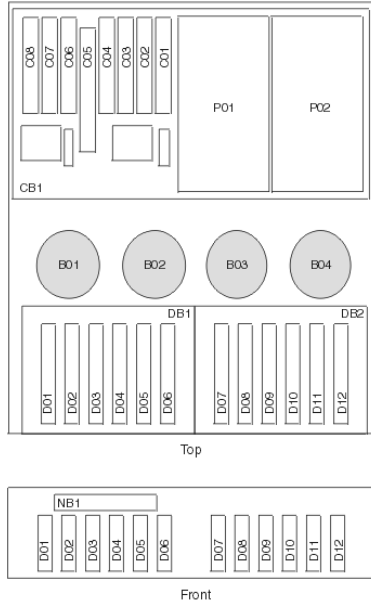
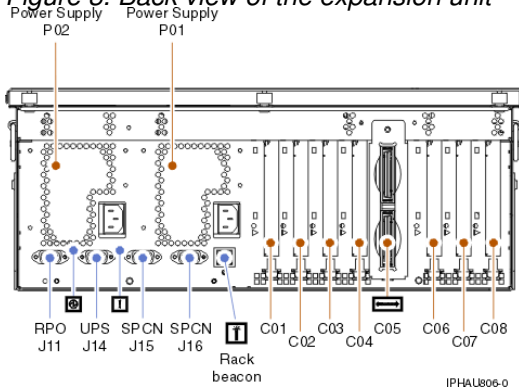


Figure 3. Back view of the expansion unit



The following table gives the components available for callout on the 05/95 and 50/95 expansion units. It matches those components with the FRU containing the component. The other columns give location information, a link to a removal and replacement procedure, and additional information.

**Attention:** After replacing any part on a server or expansion unit, perform [Verifying the repair](#).

Table 1. FRU locations and failing components for 05/95 and 50/95 expansion units

| Failing item name                                                                                                                               | Symbolic FRU name                                                                              | Physical location code                               | Link to part number                                                        | Failing item removal and replacement procedures                                                                          |
|-------------------------------------------------------------------------------------------------------------------------------------------------|------------------------------------------------------------------------------------------------|------------------------------------------------------|----------------------------------------------------------------------------|--------------------------------------------------------------------------------------------------------------------------|
| Backplane <ul style="list-style-type: none"> <li>• SPCN</li> <li>• Card enclosure or backplane</li> <li>• Multi-adapter bridge (all)</li> </ul> | TWRCARD<br>MA_BRDG<br>MABRCFG<br>PPCITWR<br>PRI_PCI<br>HSL_LNK<br>PIOCARD<br>MASBUS<br>TWRBKPL | Un-CB1                                               | <a href="#">28BE</a>                                                       | <a href="#">Exchanging the I/O backplane assembly in the 50/95, 05/95, and 11D/20 expansion units</a>                    |
| PCI adapter in slot 1                                                                                                                           | PIOCARD<br>MASBUS<br>SLOTERR                                                                   | Un-CB1-C01                                           | <a href="#">Part number catalog</a>                                        | PCI adapter                                                                                                              |
| PCI adapter in slot 2                                                                                                                           | PIOCARD<br>MASBUS<br>SLOTERR                                                                   | Un-CB1-C02                                           | <a href="#">Part number catalog</a>                                        | PCI adapter                                                                                                              |
| PCI adapter in slot 3                                                                                                                           | PIOCARD<br>MASBUS<br>SLOTERR                                                                   | Un-CB1-C03                                           | <a href="#">Part number catalog</a>                                        | PCI adapter                                                                                                              |
| PCI adapter in slot 4                                                                                                                           | PIOCARD<br>MASBUS<br>SLOTERR                                                                   | Un-CB1-C04                                           | <a href="#">Part number catalog</a>                                        | PCI adapter                                                                                                              |
| RIO adapter card <ul style="list-style-type: none"> <li>• HSL I/O adapter</li> <li>• RIO host bridge adapter</li> </ul>                         | SIIOADP<br>SIADPCD<br>SI_PHB                                                                   | Un-CB1-C05                                           | <a href="#">2886 288728E7</a>                                              | <a href="#">Exchanging the RIO card</a>                                                                                  |
| PCI adapter in slot 6                                                                                                                           | PIOCARD<br>MASBUS<br>SLOTERR                                                                   | Un-CB1-C06                                           | <a href="#">Part number catalog</a>                                        | PCI adapter                                                                                                              |
| PCI adapter in slot 7                                                                                                                           | PIOCARD<br>MASBUS<br>SLOTERR                                                                   | Un-CB1-C07                                           | <a href="#">Part number catalog</a>                                        | PCI adapter                                                                                                              |
| PCI adapter in slot 8                                                                                                                           | PIOCARD<br>MASBUS<br>SLOTERR                                                                   | Un-CB1-C08                                           | <a href="#">Part number catalog</a>                                        | PCI adapter                                                                                                              |
| PCI bridge set 1                                                                                                                                | BRDGSET<br>BRDGST1                                                                             | Un-CB1-C01<br>Un-CB1-C02<br>Un-CB1-C03<br>Un-CB1-C04 |                                                                            | Replace the system backplane and cards using the remove and replace procedures corresponding to the locations indicated. |
| PCI bridge set 2                                                                                                                                | BRDGSET<br>BRDGST2                                                                             | Un-CB1-C06<br>Un-CB1-C07<br>Un-CB1-C08               |                                                                            | Replace the system backplane and cards using the remove and replace procedures corresponding to the locations indicated. |
| Fan 1                                                                                                                                           |                                                                                                | Un-B01                                               | <a href="#">Part assembly diagrams for 05/95 and 50/95 expansion units</a> | <a href="#">Exchanging fans in the 50/95, 05/95, and 11D/20 expansion units</a>                                          |
| Fan 2                                                                                                                                           |                                                                                                | Un-B02                                               | <a href="#">Part assembly diagrams for 05/95 and 50/95 expansion units</a> | <a href="#">Exchanging fans in the 50/95, 05/95, and 11D/20 expansion units</a>                                          |
| Fan 3                                                                                                                                           |                                                                                                | Un-B03                                               | <a href="#">Part assembly diagrams for</a>                                 | <a href="#">Exchanging fans in the 50/95, 05/95, and 11D/20 expansion units</a>                                          |

Service provider information

|                                               |                                               |               |                                                            |                                                                                 |
|-----------------------------------------------|-----------------------------------------------|---------------|------------------------------------------------------------|---------------------------------------------------------------------------------|
|                                               |                                               |               | 05/95 and 50/95 expansion units                            |                                                                                 |
| Fan 4                                         |                                               | Un-B04        | Part assembly diagrams for 05/95 and 50/95 expansion units | Exchanging fans in the 50/95, 05/95, and 11D/20 expansion units                 |
| Disk unit 1                                   |                                               | Un-DB1-D01    | Part number catalog                                        | Disk drive                                                                      |
| Disk unit 2                                   |                                               | Un-DB1-D02    | Part number catalog                                        | Disk drive                                                                      |
| Disk unit 3                                   |                                               | Un-DB1-D03    | Part number catalog                                        | Disk drive                                                                      |
| Disk unit 4                                   |                                               | Un-DB1-D04    | Part number catalog                                        | Disk drive                                                                      |
| Disk unit 5                                   |                                               | Un-DB1-D05    | Part number catalog                                        | Disk drive                                                                      |
| Disk unit 6                                   |                                               | Un-DB1-D06    | Part number catalog                                        | Disk drive                                                                      |
| Disk unit 7                                   |                                               | Un-DB2-D07    | Part number catalog                                        | Disk drive                                                                      |
| Disk unit 8                                   |                                               | Un-DB2-D08    | Part number catalog                                        | Disk drive                                                                      |
| Disk unit 9                                   |                                               | Un-DB2-D09    | Part number catalog                                        | Disk drive                                                                      |
| Disk unit 10                                  |                                               | Un-DB2-D10    | Part number catalog                                        | Disk drive                                                                      |
| Disk unit 11                                  |                                               | Un-DB2-D11    | Part number catalog                                        | Disk drive                                                                      |
| Disk unit 12                                  |                                               | Un-DB2-D12    | Part number catalog                                        | Disk drive                                                                      |
| Power supply 1                                |                                               | Un-P01        | Part assembly diagrams for 05/95 and 50/95 expansion units | Power supply                                                                    |
| Power supply 2                                |                                               | Un-P02        | Part assembly diagrams for 05/95 and 50/95 expansion units | Power supply                                                                    |
| Device board 1                                |                                               | Un-DB1        | 28B9                                                       | Exchanging disk drive backplane in the 50/95, 05/95, and 11D/20 expansion units |
| Device board 2                                |                                               | Un-DB2        | 28B9                                                       | Exchanging disk drive backplane in the 50/95, 05/95, and 11D/20 expansion units |
| Display panel                                 |                                               | Un-NB1        | 250C                                                       | Exchanging the control panel in the 50/95, 05/95, and 11D/20 expansion units    |
| RIO adapter card connector (bottom connector) | HSL_LNK<br>HSL2<br>HSL2_xx<br>HSLH<br>HSLH_xx | Un-CB1-C05-00 | Part number catalog                                        | Exchanging RIO cables                                                           |
| RIO adapter card connector                    | HSL_LNK<br>HSL2<br>HSL2_xx<br>HSLH<br>HSLH_xx | Un-CB1-C05-00 | Part number catalog                                        | Exchanging RIO cables                                                           |

**Notes:**

1. Card positions C01 and C06 are required to be I/O processors.
2. J11 is an RPO connection, J14 is a uninterruptible power supply connector, J15 is an SPCN 1 connector, and J16 is an SPCN 2 connector.
3. Multi-adapter bridge domains are labeled PCI Bridge Set inside the expansion unit.
4. The following table provides information necessary to identify the IOP to which IOAs are assigned.
  - ◆ The left column indicates the domain in which IOA assignment is allowed.
  - ◆ The right column is used to determine the IOP to which an IOA is assigned.
  - ◆ The first position in the list must be an IOP. The remaining positions may be IOPs or IOAs. IOAs are assigned to the first IOP located to their left in the list. Although IOAs can be manually reassigned using SST/DST, the IOA assignments return to the default order after each IPL.

Table 2. Identify the IOP to which IOAs are assigned

| Multi-adapter bridge domain / PCI bridge set | IOA assignment rules |
|----------------------------------------------|----------------------|
| C01 - C04                                    | C01, C02, C03, C04   |
| C06 - C08                                    | C06, C07, C08        |

Parent topic: [Finding part locations](#)

---

## Exchanging the I/O backplane assembly in the 50/95, 05/95, and 11D/20 expansion units

Use this procedure in conjunction with [Powering off an expansion unit](#) to remove or replace the I/O backplane assembly in the 50/95, 05/95, and 11D/20 expansion units.

1. Record the activated firmware level of the server for use in this procedure. The activated firmware level of the server can be found in the upper-right corner of the ASMI utility.
2. If this is a 7311-D20 expansion unit connected to a server with an activated firmware level that is earlier than SF235, the partitions that own slots in the expansion unit must be powered off during this procedure. Power the partitions off now. This power-off action can be accomplished by powering off individual partitions, or powering off the server.
3. Power off the expansion unit (see [Powering off an expansion unit](#)).
4. Remove the ac power cord(s) from the expansion unit.
5. If you are servicing a rack-mounted unit, place the unit in the service position (see [Place the rack-mounted system or expansion unit in the service position](#)).
6. Remove the side cover (see [Exchanging covers in the 50/95 and 05/95 expansion units](#)).
7. Remove the PCI card access cover.
8. Remove the PCI cards, RIO I/O bridge adapter, and the card dividers.
9. Remove the power supplies.
10. Remove the five screws (three from the side and two from the back) that hold the backplane to the expansion unit. Notice the aligning pins near the top of the board, and the power connections near the bottom of the board, for use later when you reinstall the board.
11. Install the new backplane by reversing the procedure described in steps 5 to 10.
12. Reconnect the power cord(s) and/or the power supply cords that you disconnected earlier.

**Note:** If the server is powered on, the expansion unit will power on automatically.

13. Perform [Setting expansion unit configuration ID and MTMS value](#) and then continue with the next step

of this procedure.

**Note:** If this is a 7311-D20 expansion unit connected to a server with an activated firmware level that is lower than SF235, and the server is currently powered off, when instructed to power on the server in Setting expansion unit configuration ID and MTMS value it must be powered on to firmware standby, not firmware running.

14. If this is a 7311-D20 expansion unit connected to a server with an activated firmware level that is lower than SF235, go to step 15. Otherwise, go to step 17.
15. If the server is HMC-managed, disconnect one of the SPCN cables from the 7311-D20 expansion unit (only one of them). Wait 30 seconds, then reconnect it. For a server that is not managed by an HMC, this step can be omitted.
16. An SPCN microcode download to the 7311-D20 expansion unit may or may not be occurring.
  - ◆ If an SPCN microcode download does not occur, go to step 17.
  - ◆ If an SPCN microcode download does occur, wait for the download to finish. Then power the server off and back on again. Partitions may be started at this time. Then go to step 17.
  - ◆ There are two ways to determine if an SPCN download is occurring:
    - ◇ Look at the Error/Event Logs using the ASMI utility
      - Expand **System Service Aids**.
      - Select **Error/Event Logs**.
      - A 1xxx9107 SRC in the informational logs section indicates that an SPCN download was started.
      - A 1xxx91DD SRC in the informational logs section indicates that an SPCN download completed.
    - ◇ Look at the expansion unit rack address using the ASMI utility.
      - Expand **System Configuration**.
      - Select **Configure I/O Enclosures**.
      - If the rack address for the 7311-D20 expansion unit is a 1-byte value, an SPCN download is occurring.
      - If the rack address is a 2-byte value, the SPCN download has completed or is not needed.
17. Go to [Verifying the repair](#). This ends the procedure.

**Parent topic:** [Removing and replacing parts in the 50/95, 05/95, and 11D/20 expansion units](#)

---

## Exchanging the RIO card

Use this procedure in conjunction with [Powering off an expansion unit](#) to remove or replace the RIO card.

**Parent topic:** [Removing and replacing parts in the 50/95, 05/95, and 11D/20 expansion units](#)

### Remove the RIO card

To remove the RIO card from the subsystem, do the following:

1. Open the rack front door.
2. Power off the expansion unit (see [Powering off an expansion unit](#)).
3. Put the expansion unit into the service position as described in [Place the expansion unit in the service position](#).
4. Remove the ac power cord from the expansion unit that you are working on.
5. Open the service access cover.
6. Disconnect the RIO-2 cables from the RIO connectors located on the rear of the subsystem.

7. Identify, and then disconnect and label all cables that cross over the top of the RIO card. These cables might interfere with the removal and installation of the RIO card.
8. Release the release latches located on top of the RIO card.
9. Simultaneously lift both retention handles.
10. Pivot the release handles up until they are perpendicular (90 degrees) to the top of the RIO card.

**Note:** By placing the handles perpendicular to the top of the RIO card, the base or hinged portion of each handle acts as a cam and will gently pry the RIO card up, disconnecting it from its docking connector.

11. Remove the RIO card from the subsystem chassis, and put it in a safe place.

## Replace the RIO card

To replace the RIO bus card, do the following:

1. Grasp the two RIO card release handles.
2. Pivot both handles upward to 90 degrees, ensuring that the handles are perpendicular to the RIO card. The handle cams have now been placed into the correct position to assist you when seating the RIO card into its docking connector.
3. Before inserting the RIO card into its bay, observe the alignment bracket. The alignment bracket is secured to the power bulkhead.
4. Insert the RIO card into its bay. Ensure that the power cable receptacle located on the back of the RIO card is facing the back of the subsystem chassis.
5. Lower the RIO card through the alignment bracket. The alignment bracket will catch the back edge of the RIO card closest to it.

The RIO card should now be resting on the top of its docking connector. The docking connector has two large alignment pins located on each end. These alignment pins will ensure alignment of the RIO card to its docking connector when seated.

6. Lower the RIO card locking handles, carefully seating the RIO card into the docking connector. The plastic latch located beneath each handle clicks when the RIO card is fully seated. This click also indicates that the handle is locked in the closed position.
7. Reconnect the RIO-2 cables to the RIO card connectors located on the back of the chassis.
8. Reconnect the cables that were disconnected during the RIO card removal.
9. Reconnect the power source to the expansion unit.
10. Close and then secure the service access cover with the three thumbscrews located on its back edge.
11. Return the expansion unit to the operating position as described in [Place the expansion unit in the operating position](#).
12. Power on the expansion unit as described in [Powering off an expansion unit](#).
13. Close the rack front door.

---

## Part assembly diagrams for 05/95 and 50/95 expansion units

### Cover assembly for 50/95 expansion unit

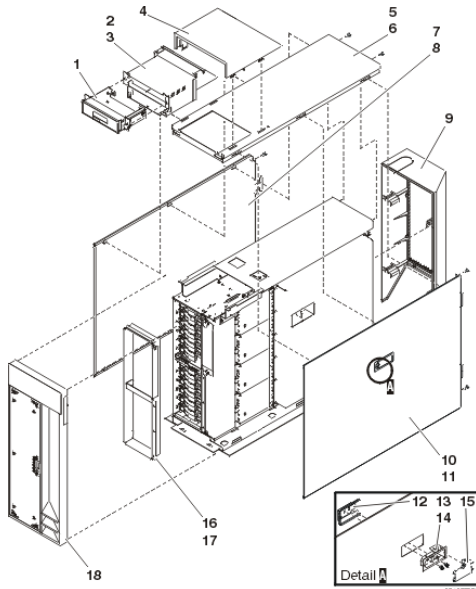


Table 1. Cover assembly part numbers for 50/95 expansion unit

| Index | Part number | Units | Description                      |
|-------|-------------|-------|----------------------------------|
| 1     | 53P0330     | 1     | Display panel tray assembly      |
| 2     | NONUM       | 1     | Display panel enclosure assembly |
| 3     | 53P0320     | 5     | Screw                            |
| 4     | 53P0308     | 1     | Cover, display panel             |
| 5     | 53P0280     | 1     | Cover, top                       |
| 6     | 53P0320     | 2     | Screw                            |
| 7     | 53P0285     | 1     | Cover, left side                 |
| 8     | 53P0320     | 2     | Screw                            |
| 9     | 53P0303     | 1     | Cover assembly, back             |
| 10    | 39J1179     | 1     | Cover assembly, right side       |
| 11    | 53P0320     | 2     | Screw                            |
| 12    | 53P0322     | 1     | EMC bracket                      |
| 13    | 06P5858     | 1     | Latch housing                    |
| 14    | 03K9553     | 2     | Screw, M3.5 x 7                  |
| 15    | 06P5857     | 1     | Latch handle                     |
| 16    | 53P0234     | 1     | Bracket, DASD filler             |
| 17    | 44H7336     | 4     | Screw                            |
| 18    | 39J3317     | 1     | Cover assembly, front            |

**Final assembly for 05/95 expansion unit (rack mounted)**

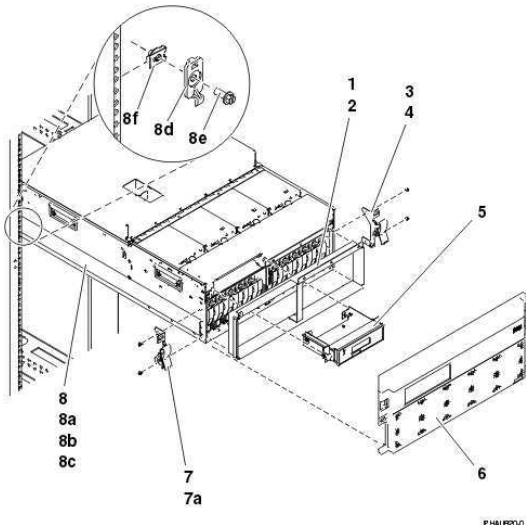


Table 2. Final assembly part numbers for 05/95 expansion unit (rack mounted)

| Index | Part number | Units | Description                                                                                    |
|-------|-------------|-------|------------------------------------------------------------------------------------------------|
| 1     | 53P0234     | 1     | Bracket, DASD filler                                                                           |
| 2     | 75G2878     | 4     | Screw, M3.5 x 8mm                                                                              |
| 3     | 53P2573     | 1     | Latch assembly, right                                                                          |
| 4     | 75G2878     | 2     | Screw, M3.5 x 8mm                                                                              |
| 5     | 53P0330     | 1     | Display panel tray assembly                                                                    |
| 6     | 39J3326     | 1     | Cover assembly, front                                                                          |
| 7     | 53P2572     | 1     | Latch assembly, left                                                                           |
| 7a    | 75G2878     | 2     | Screw, M3.5 x 8mm                                                                              |
| 8     | 42R4300     | 1     | Cable management arm. General location, but not shown.                                         |
| 8a    | 42R5254     | 1     | Slide assembly, left side                                                                      |
| 8b    | 42R5255     | 1     | Slide assembly, right side                                                                     |
| 8c    | 42R5260     | AR    | Rail-mounting kit                                                                              |
| 8d    | NONUM       | AR    | <ul style="list-style-type: none"> <li>• Rack latch (included in rail-mounting kit)</li> </ul> |
| 8e    | NONUM       | AR    | <ul style="list-style-type: none"> <li>• Screw (included in rail-mounting kit)</li> </ul>      |
| 8f    | NONUM       | AR    | <ul style="list-style-type: none"> <li>• Nut clip (included in rail-mounting kit)</li> </ul>   |

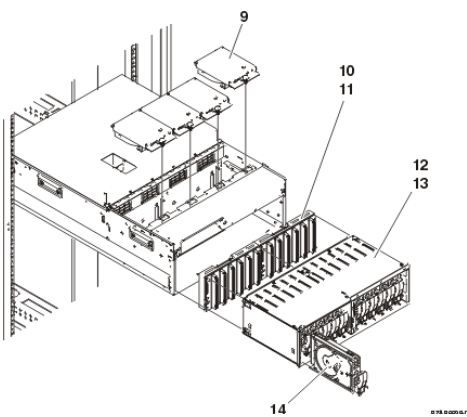




Table 3. Final assembly part numbers for 05/95 expansion unit (rack mounted)

| Index | Part number                         | Units | Description                   |
|-------|-------------------------------------|-------|-------------------------------|
| 9     | 39J1176                             | 4     | Blower assembly               |
| 10    | 39J1695                             | 2     | Disk unit enclosure backplane |
| 11    | 75G2878                             | 8     | Screw, M3.5 x 8mm             |
| 12    | 53P0250                             | 2     | Disk unit enclosure           |
| 13    | 75G2878                             | 4     | Screw, M3.5 x 8mm             |
| 14    | See <a href="#">Disk unit parts</a> | AR    | Disk unit                     |
| 14    | See <a href="#">Disk unit parts</a> | AR    | Disk unit                     |

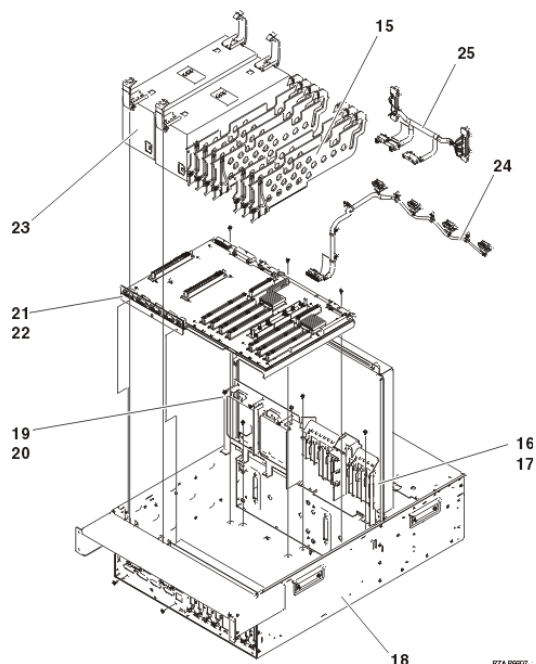


Table 4. Final assembly part numbers for 05/95 expansion unit (rack mounted)

| Index | Part number | Units | Description                |
|-------|-------------|-------|----------------------------|
| 15    | 53P2728     | 1     | PCI divider                |
|       | 53P2729     | 1     | PCI divider (C01, C06)     |
| 16    | NONUM       | NP    | PCI headstock              |
| 17    | 75G2878     | 3     | Screw, M3.5 x 8mm          |
| 18    | 53P0222     | NP    | Frame assembly             |
| 19    | NONUM       | NP    | Power bulkhead             |
| 20    | 75G2878     | 5     | Screw, M3.5 x 8mm          |
| 21    | 53P2970     | AR    | PCI backplane assembly CB1 |
| 22    | 75G2878     | 5     | Screw, M3.5 x 8mm          |
| 23    | 21P7602     | AR    | Power supply               |
| 23    | 39J1175     | AR    | Filler, power supply       |
| 24    | 53P4065     | 1     | AMD cable                  |
| 25    | 53P4016     | 1     | Disk unit cable            |

**Final assembly for 50/95 expansion unit**

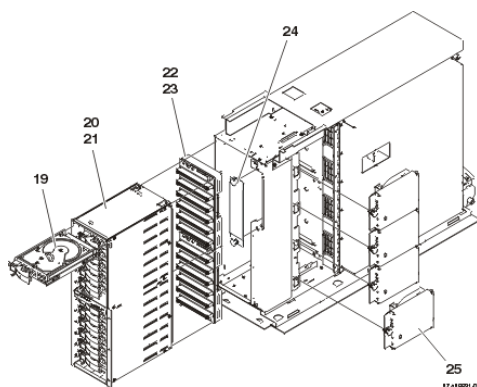


Table 5. Final assembly part numbers for 50/95 expansion unit

| Index | Part numbers | Units | Description                         |
|-------|--------------|-------|-------------------------------------|
| 19    | 21P3593      | AR    | Disk unit                           |
| 19    | 24L0900      | AR    | Disk unit                           |
| 20    | 53P0250      | 2     | Disk unit enclosure                 |
| 21    | 44H7366      | AR    | Screw, M3.5 x 8mm                   |
| 21    | 53P0319      | AR    | Screw                               |
| 22    | 39J1695      | 2     | Disk unit enclosure backplane       |
| 23    | 53P0321      | 8     | Screw                               |
| 24    | 39J1176      | 1     | EMC enclosure                       |
| 25    | 39J1176      | 4     | Air-moving device (blower assembly) |

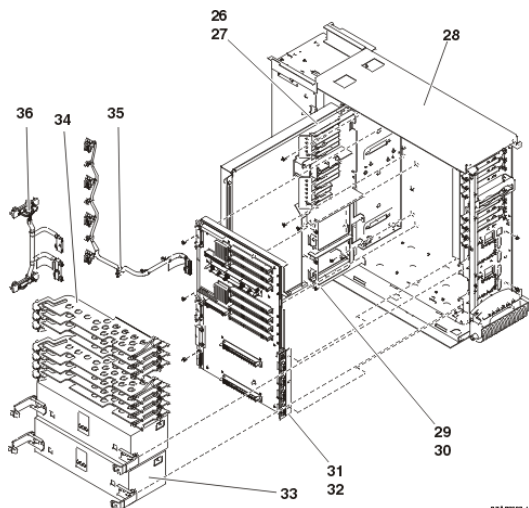


Table 6. Final assembly part numbers for 50/95 expansion unit

| Index | Part numbers | Units | Description            |
|-------|--------------|-------|------------------------|
| 26    | 53P0249      | 1     | Bracket, PCI Headstock |
| 27    | 44H7366      | 3     | Screw                  |
| 28    | 53P0222      | NP    | Frame assembly         |
| 29    | 21P7602      | 1     | Bracket, power supply  |
| 30    | 44H7366      | 4     | Screw                  |

|    |         |    |                              |
|----|---------|----|------------------------------|
| 31 | 53P0239 | 1  | Processor backplane assembly |
| 32 | 44H7366 | 5  | Screw                        |
| 33 | 21P7602 | AR | Power supply                 |
| 33 | 39J1175 | AR | Filler, Power supply         |
| 34 | 53P2728 | AR | PCI divider                  |
| 34 | 53P2729 | AR | PCI divider                  |

Parent topic: [Part assembly diagrams](#)

---

## Exchanging fans in the 50/95, 05/95, and 11D/20 expansion units

Use this procedure to remove or replace a fan or air moving device (AMD) in the 50/95, 05/95, and 11D/20 expansion units.

**Attention:** At least three running fans and two power supplies *must* be installed and powered on to perform this procedure.

1. Are there at least three running fans and two power supplies installed and powered on in the expansion unit?
  - ◆ Yes: Continue with the next step.
  - ◆ No: Perform the following:
    - a. Power off the expansion unit ([Powering off an expansion unit](#)).
    - b. Remove the power cord from the rear of the expansion unit, and continue with the next step.
2. If you are servicing a rack-mounted unit, place the unit in the service position (see [Place the rack-mounted system or expansion unit in the service position](#)).
3. Remove the right or top side cover, depending on expansion unit orientation (see [Exchanging covers in the 50/95 and 05/95 expansion units](#)).
4. Pull the fastener on the front of the fan casing.
5. Pull open and remove the fan. The power connection will undock automatically.
6. Install the new fan by reversing this procedure. After exchanging an item, go to [Verifying the repair](#). This ends the procedure.

Parent topic: [Removing and replacing parts in the 50/95, 05/95, and 11D/20 expansion units](#)

---

## Exchanging disk drive backplane in the 50/95, 05/95, and 11D/20 expansion units

Use this procedure to remove or replace a disk drive backplane in the 50/95, 05/95, and 11D/20 expansion units.

1. Power off the expansion unit (see [Powering off an expansion unit](#)).
2. Unplug the power cord from the back of the expansion unit.
3. If you are servicing a rack-mounted unit, place the unit in the service position (see [Place the rack-mounted system or expansion unit in the service position](#)).
4. Remove the front and right side covers (see [Exchanging covers in the 50/95 and 05/95 expansion units](#)).

5. Remove the EMC shield in front of the disk units by pulling out on the two side latches.
6. Remove the disk units from the disk unit enclosure. Label the position of each disk unit.
7. Remove the screws holding the disk unit enclosure to the frame. The screws are located on the front and inside rear of the disk unit enclosure.
8. Unplug and remove the cables plugged into the back of the disk drive backplane.
9. Pull the disk unit enclosure out of the frame.
10. Remove the disk drive backplane from the back of the disk unit enclosure.
11. Install a new disk drive backplane by reversing this removal procedure. This ends the procedure.

**Parent topic:** [Removing and replacing parts in the 50/95, 05/95, and 11D/20 expansion units](#)

---

## Exchanging the control panel in the 50/95, 05/95, and 11D/20 expansion units

Use this procedure to remove or install the control or display panel in the 50/95, 05/95, and 11D/20 expansion units.

1. Power off the expansion unit (see [Powering off an expansion unit](#)).
2. Remove the front cover (see [Exchanging covers in the 50/95 and 05/95 expansion units](#)).
3. Remove the ac power cord from the expansion unit you are working on.
4. Pull the locks on each side of the control panel.
5. Slide the control panel approximately halfway out and remove the cables from the rear of the panel.
6. Remove the control panel.
7. Install a new control panel by reversing this procedure. After exchanging an item, go to [Verifying the repair](#). This ends the procedure.

**Parent topic:** [Removing and replacing parts in the 50/95, 05/95, and 11D/20 expansion units](#)

---

## Locations 57/86, 57/87, D24, and T24 expansion units

**Note:** The known logical location codes for this unit are listed next to the corresponding physical location in the following information. If you are working with a logical location code for this unit and it is not listed in the following information, contact your next level of support.

The following diagrams show the field replaceable unit (FRU) layout. Use them with the following tables.

The following table gives the components available for callout. It matches those components with the FRU containing the component. The other columns give location information, a link to a removal and replacement procedure, and additional information.

**Attention:** After replacing any part on a server or expansion unit, perform [Verifying the repair](#).

Figure 1. Front view

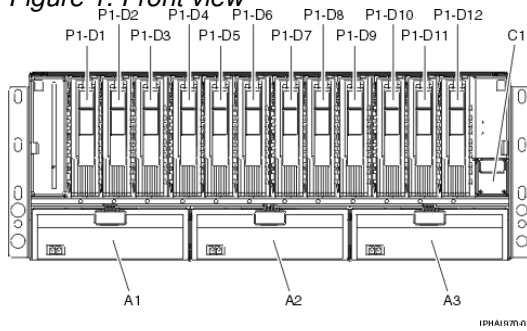


Figure 2. Back view

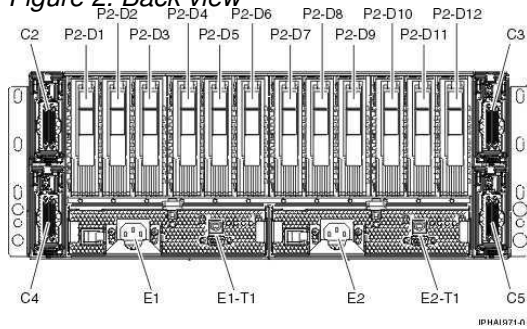


Table 1. FRU locations and failing components

| Failing item name                   | Symbolic failing item name | Physical location code | Identify LED | Link to part number                    | Failing item removal and replacement procedures |
|-------------------------------------|----------------------------|------------------------|--------------|----------------------------------------|-------------------------------------------------|
| Disk drive backplane 1              |                            | Un-P1                  | No           |                                        |                                                 |
| Disk drive backplane 2              |                            | Un-P2                  | No           |                                        |                                                 |
| Power distribution backplane        |                            | Un-P3                  | No           |                                        |                                                 |
| Fan 1 (left)                        | DISKFAN                    | Un-A1                  | No           | <a href="#">Part assembly diagrams</a> |                                                 |
| Fan 2                               | DISKFAN                    | Un-A2                  | No           | <a href="#">Part assembly diagrams</a> |                                                 |
| Fan 3 (right)                       | DISKFAN                    | Un-A3                  | No           | <a href="#">Part assembly diagrams</a> |                                                 |
| VPD card                            |                            | Un-C1                  | No           |                                        |                                                 |
| SCSI interface card 1 (top left)    | DEVBPLN                    | Un-C2                  | No           | <a href="#">Part assembly diagrams</a> |                                                 |
| SCSI interface card 2 (top right)   | DEVBPLN                    | Un-C3                  | No           | <a href="#">Part assembly diagrams</a> |                                                 |
| SCSI interface card 3 (bottom left) | DEVBPLN                    | Un-C4                  | No           | <a href="#">Part assembly diagrams</a> |                                                 |
| SCSI interface                      | DEVBPLN                    | Un-C5                  | No           | <a href="#">Part assembly diagrams</a> |                                                 |

Service provider information

|                                  |         |                                                                                                               |     |                                            |                            |
|----------------------------------|---------|---------------------------------------------------------------------------------------------------------------|-----|--------------------------------------------|----------------------------|
| card 4<br>(bottom<br>right)      |         |                                                                                                               |     |                                            |                            |
| Crossover<br>card 1 (left)       |         | Un-C6                                                                                                         | No  | <a href="#">Part assembly<br/>diagrams</a> |                            |
| Crossover<br>card 2 (right)      |         | Un-C7                                                                                                         | No  | <a href="#">Part assembly<br/>diagrams</a> |                            |
| Power<br>supply 1<br>(left)      | DISKPWR | Un-E1                                                                                                         | No  | <a href="#">Power parts</a>                |                            |
| Rack<br>indicator<br>connector   |         | Un-E1-T1                                                                                                      | No  |                                            |                            |
| Power<br>supply 2<br>(right)     | DISKPWR | Un-E2                                                                                                         | No  | <a href="#">Power parts</a>                |                            |
| Rack<br>indicator<br>connector   |         | Un-E2-T1                                                                                                      | No  |                                            |                            |
| <b>Device physical locations</b> |         |                                                                                                               |     |                                            |                            |
| Disk drive 1<br>(front)          |         | Un-P1-D01<br>(logical location<br>Un-Px- Ty-L5-L0 -<br>single or<br>Un-Px-Ty-L13-L0 -<br>dual <sup>1)</sup> ) | Yes | <a href="#">Disk unit parts</a>            | <a href="#">Disk drive</a> |
| Disk drive 2<br>(front)          |         | Un-P1-D02<br>(logical location<br>Un-Px- Ty-L4-L0 -<br>single or<br>Un-Px-Ty-L12-L0 -<br>dual <sup>1)</sup> ) | Yes | <a href="#">Disk unit parts</a>            | <a href="#">Disk drive</a> |
| Disk drive 3<br>(front)          |         | Un-P1-D03<br>(logical location<br>Un-Px- Ty-L3-L0 -<br>single or<br>Un-Px-Ty-L11-L0 -<br>dual <sup>1)</sup> ) | Yes | <a href="#">Disk unit parts</a>            | <a href="#">Disk drive</a> |
| Disk drive 4<br>(front)          |         | Un-P1-D04<br>(logical location<br>Un-Px- Ty-L2-L0 -<br>single or<br>Un-Px-Ty-L10-L0 -<br>dual <sup>1)</sup> ) | Yes | <a href="#">Disk unit parts</a>            | <a href="#">Disk drive</a> |
| Disk drive 5<br>(front)          |         | Un-P1-D05<br>(logical location<br>Un-Px- Ty-L1-L0 -<br>single or<br>Un-Px-Ty-L9-L0 -<br>dual <sup>1)</sup> )  | Yes | <a href="#">Disk unit parts</a>            | <a href="#">Disk drive</a> |
| Disk drive 6<br>(front)          |         | Un-P1-D06<br>(logical location<br>Un-Px- Ty-L0-L0 -<br>single or<br>Un-Px-Ty-L8-L0 -<br>dual <sup>1)</sup> )  | Yes | <a href="#">Disk unit parts</a>            | <a href="#">Disk drive</a> |
| Disk drive 7<br>(front)          |         | Un-P1-D07<br>(logical location<br>Un-Px- Ty-L5-L0<br><sup>1)</sup> )                                          | Yes | <a href="#">Disk unit parts</a>            | <a href="#">Disk drive</a> |
|                                  |         |                                                                                                               | Yes | <a href="#">Disk unit parts</a>            | <a href="#">Disk drive</a> |

## Service provider information

|                       |  |                                                                                                |     |                 |            |
|-----------------------|--|------------------------------------------------------------------------------------------------|-----|-----------------|------------|
| Disk drive 8 (front)  |  | Un-P1-D08 (logical location Un-Px- Ty-L4-L0 <sup>1)</sup> )                                    |     |                 |            |
| Disk drive 9 (front)  |  | Un-P1-D09 (logical location Un-Px- Ty-L3-L0 <sup>1)</sup> )                                    | Yes | Disk unit parts | Disk drive |
| Disk drive 10 (front) |  | Un-P1-D10 (logical location Un-Px- Ty-L2-L0 <sup>1)</sup> )                                    | Yes | Disk unit parts | Disk drive |
| Disk drive 11 (front) |  | Un-P1-D11 (logical location Un-Px- Ty-L1-L0 <sup>1)</sup> )                                    | Yes | Disk unit parts | Disk drive |
| Disk drive 12 (front) |  | Un-P1-D12 (logical location Un-Px- Ty-L0-L0 <sup>1)</sup> )                                    | Yes | Disk unit parts | Disk drive |
| Disk drive 1 (back)   |  | Un-P2-D01 (logical location Un-Px- Ty-L5-L0 - single or Un-Px-Ty-L13-L0 - dual <sup>1)</sup> ) | Yes | Disk unit parts | Disk drive |
| Disk drive 2 (back)   |  | Un-P2-D02 (logical location Un-Px- Ty-L4-L0 - single or Un-Px-Ty-L12-L0 - dual <sup>1)</sup> ) | Yes | Disk unit parts | Disk drive |
| Disk drive 3 (back)   |  | Un-P2-D03 (logical location Un-Px- Ty-L3-L0 - single or Un-Px-Ty-L11-L0 - dual <sup>1)</sup> ) | Yes | Disk unit parts | Disk drive |
| Disk drive 4 (back)   |  | Un-P2-D04 (logical location Un-Px- Ty-L2-L0 - single or Un-Px-Ty-L10-L0 - dual <sup>1)</sup> ) | Yes | Disk unit parts | Disk drive |
| Disk drive 5 (back)   |  | Un-P2-D05 (logical location Un-Px- Ty-L1-L0 - single or Un-Px-Ty-L9-L0 - dual <sup>1)</sup> )  | Yes | Disk unit parts | Disk drive |
| Disk drive 6 (back)   |  | Un-P2-D06 (logical location Un-Px- Ty-L0-L0 - single or Un-Px-Ty-L8-L0 - dual <sup>1)</sup> )  | Yes | Disk unit parts | Disk drive |
| Disk drive 7 (back)   |  | Un-P2-D07 (logical location Un-Px- Ty-L5-L0 <sup>1)</sup> )                                    | Yes | Disk unit parts | Disk drive |
| Disk drive 8 (back)   |  | Un-P2-D08 (logical location                                                                    | Yes | Disk unit parts | Disk drive |

Service provider information

|                                                                                                                                                                                                                                                                                                                                                         |  |                                                                                  |     |                 |            |
|---------------------------------------------------------------------------------------------------------------------------------------------------------------------------------------------------------------------------------------------------------------------------------------------------------------------------------------------------------|--|----------------------------------------------------------------------------------|-----|-----------------|------------|
|                                                                                                                                                                                                                                                                                                                                                         |  | $U_n$ - $P_x$ - $T_y$ -L4-L0 <sup>1)</sup>                                       |     |                 |            |
| Disk drive 9 (back)                                                                                                                                                                                                                                                                                                                                     |  | $U_n$ -P2-D09<br>(logical location<br>$U_n$ - $P_x$ - $T_y$ -L3-L0 <sup>1)</sup> | Yes | Disk unit parts | Disk drive |
| Disk drive 10 (back)                                                                                                                                                                                                                                                                                                                                    |  | $U_n$ -P2-D10<br>(logical location<br>$U_n$ - $P_x$ - $T_y$ -L2-L0 <sup>1)</sup> | Yes | Disk unit parts | Disk drive |
| Disk drive 11 (back)                                                                                                                                                                                                                                                                                                                                    |  | $U_n$ -P2-D11<br>(logical location<br>$U_n$ - $P_x$ - $T_y$ -L1-L0 <sup>1)</sup> | Yes | Disk unit parts | Disk drive |
| Disk drive 12 (back)                                                                                                                                                                                                                                                                                                                                    |  | $U_n$ -P2-D12<br>(logical location<br>$U_n$ - $P_x$ - $T_y$ -L0-L0 <sup>1)</sup> | Yes | Disk unit parts | Disk drive |
| <sup>1</sup> Where: <ul style="list-style-type: none"> <li>• <math>U_n</math>-<math>P_x</math> is the backplane of the unit where the SCSI PCI adapter is installed.</li> <li>• <math>T_y</math> is the connector on the SCSI PCI adapter.</li> <li>• single is a single SCSI interface card.</li> <li>• dual is a dual SCSI interface card.</li> </ul> |  |                                                                                  |     |                 |            |

Parent topic: [Finding part locations](#)

## Locations 57/91, 57/94, and 406/1D expansion units

**Note:** The known logical location codes for this unit are listed next to the corresponding physical location in the following information. If you are working with a logical location code for this unit and it is not listed in the following information, contact your next level of support.

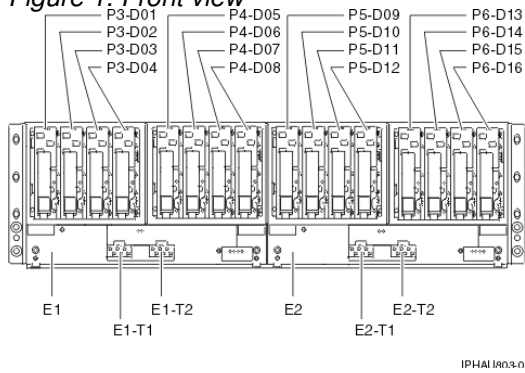
The following diagrams show the field replaceable unit (FRU) layout for 57/91 and 57/94. Use them with the following tables.

The following diagrams also show the field replaceable unit (FRU) layout in the 406/1D expansion unit. After you locate your part in the 406/1D expansion unit, refer to the 406/1D service guide for part number information.

**Note:** Some units may have labels that designate location codes other than those shown in the following illustrations and tables. If that is the case, use the location codes shown in the following illustrations and tables.

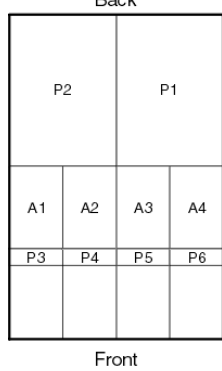


Figure 1. Front view



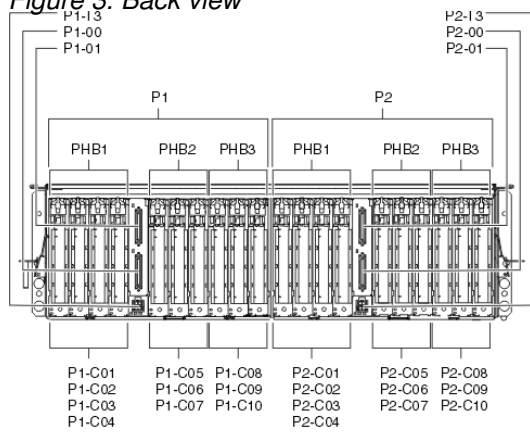
IPHA1803-n

Figure 2. Top view



IPHA1804-c

Figure 3. Back view



IPHA1805-1

The following table gives the components available for callout. It matches those components with the FRU containing the component. The other columns give location information, a link to a removal and replacement procedure, and additional information.

**Attention:** After replacing any part on a server or expansion unit, perform [Verifying the repair](#).

Table 1. FRU locations and failing components

| Failing item name                                                                                                      | Symbolic failing item name                                                                                                               | Physical location code | Attention LED | Link to part number          | Failing item removal and replacement procedures                                              |
|------------------------------------------------------------------------------------------------------------------------|------------------------------------------------------------------------------------------------------------------------------------------|------------------------|---------------|------------------------------|----------------------------------------------------------------------------------------------|
| Backplane 1<br><ul style="list-style-type: none"> <li>• RIO</li> <li>• SCSI Controller</li> <li>• SPCN node</li> </ul> | MA_BRDG<br>MABRCFG<br>PPCITWR<br>PRI_PCI<br>SLEBHB<br>SIIOADP<br>PIOCARD<br>MASBUS<br>SLOTERR<br>SIADPCD<br>HSL_I4<br>HSL_LNK<br>TWRPLNR | Un-P1                  | Yes           | <a href="#">28C6</a>         | <a href="#">Removing and replacing parts in the 57/91, 57/94, and 406/1D expansion units</a> |
| Backplane 2<br><ul style="list-style-type: none"> <li>• RIO</li> <li>• SCSI Controller</li> <li>• SPCN node</li> </ul> | MA_BRDG<br>MABRCFG<br>PPCITWR<br>PRI_PCI<br>SLEBHB<br>SIIOADP<br>PIOCARD<br>MASBUS<br>SLOTERR<br>SIADPCD<br>HSL_I4<br>HSL_LNK<br>TWRPLNR | Un-P2                  | Yes           | <a href="#">28C6</a>         | <a href="#">Removing and replacing parts in the 57/91, 57/94, and 406/1D expansion units</a> |
| Disk drive backplane                                                                                                   |                                                                                                                                          | Un-P3                  | Yes           | <a href="#">Backplanes</a>   | <a href="#">Removing and replacing parts in the 57/91, 57/94, and 406/1D expansion units</a> |
| Disk drive backplane                                                                                                   |                                                                                                                                          | Un-P4                  | Yes           | <a href="#">Backplanes</a>   | <a href="#">Removing and replacing parts in the 57/91, 57/94, and 406/1D expansion units</a> |
| Disk drive backplane                                                                                                   |                                                                                                                                          | Un-P5                  | Yes           | <a href="#">Backplanes</a>   | <a href="#">Removing and replacing parts in the 57/91, 57/94, and 406/1D expansion units</a> |
| Disk drive backplane                                                                                                   |                                                                                                                                          | Un-P6                  | Yes           | <a href="#">Backplanes</a>   | <a href="#">Removing and replacing parts in the 57/91, 57/94, and 406/1D expansion units</a> |
| PCI adapter in slot 1                                                                                                  | PIOCARD<br>MASBUS<br>SLOTERR                                                                                                             | Un-P1-C01              | Yes           | <a href="#">System parts</a> | <a href="#">Removing and replacing parts in the 57/91, 57/94, and 406/1D expansion units</a> |
| PCI adapter in slot 2                                                                                                  | PIOCARD<br>MASBUS<br>SLOTERR                                                                                                             | Un-P1-C02              | Yes           | <a href="#">System parts</a> | <a href="#">Removing and replacing parts in the 57/91, 57/94, and 406/1D expansion units</a> |
| PCI adapter in slot 3                                                                                                  | PIOCARD<br>MASBUS<br>SLOTERR                                                                                                             | Un-P1-C03              | Yes           | <a href="#">System parts</a> | <a href="#">Removing and replacing parts in the 57/91, 57/94, and 406/1D expansion units</a> |
| PCI adapter in slot 4                                                                                                  | PIOCARD<br>MASBUS<br>SLOTERR                                                                                                             | Un-P1-C04              | Yes           | <a href="#">System parts</a> | <a href="#">Removing and replacing parts in the 57/91, 57/94, and 406/1D expansion units</a> |

## Service provider information

|                        |                              |                                                  |     |              |                                                                                                          |
|------------------------|------------------------------|--------------------------------------------------|-----|--------------|----------------------------------------------------------------------------------------------------------|
| PCI adapter in slot 5  | PIOCARD<br>MASBUS<br>SLOTERR | Un-P1-C05                                        | Yes | System parts | Removing and replacing parts in the 57/91, 57/94, and 406/1D expansion units                             |
| PCI adapter in slot 6  | PIOCARD<br>MASBUS<br>SLOTERR | Un-P1-C06                                        | Yes | System parts | Removing and replacing parts in the 57/91, 57/94, and 406/1D expansion units                             |
| PCI adapter in slot 7  | PIOCARD<br>MASBUS<br>SLOTERR | Un-P1-C07                                        | Yes | System parts | Removing and replacing parts in the 57/91, 57/94, and 406/1D expansion units                             |
| PCI adapter in slot 8  | PIOCARD<br>MASBUS<br>SLOTERR | Un-P1-C08                                        | Yes | System parts | Removing and replacing parts in the 57/91, 57/94, and 406/1D expansion units                             |
| PCI adapter in slot 9  | PIOCARD<br>MASBUS<br>SLOTERR | Un-P1-C09                                        | Yes | System parts | Removing and replacing parts in the 57/91, 57/94, and 406/1D expansion units                             |
| PCI adapter in slot 10 | PIOCARD<br>MASBUS<br>SLOTERR | Un-P1-C10                                        | Yes | System parts | Removing and replacing parts in the 57/91, 57/94, and 406/1D expansion units                             |
| PHB (PCI bridge set) 1 | BRDGSET<br>BRDGST1           | Un-P1-C01<br>Un-P1-C02<br>Un-P1-C03<br>Un-P1-C04 |     |              | Replace the cards using the removal and replacement procedures corresponding to the locations indicated. |
| PHB (PCI bridge set) 2 | BRDGSET<br>BRDGST2           | Un-P1-C05<br>Un-P1-C06<br>Un-P1-C07              |     |              |                                                                                                          |
| PHB (PCI bridge set) 3 | BRDGSET<br>BRDGST3           | Un-P1-C08<br>Un-P1-C09<br>Un-P1-C10              |     |              |                                                                                                          |
| PCI adapter in slot 1  | PIOCARD<br>MASBUS<br>SLOTERR | Un-P2-C01                                        | Yes | System parts | PCI adapter                                                                                              |
| PCI adapter in slot 2  | PIOCARD<br>MASBUS<br>SLOTERR | Un-P2-C02                                        | Yes | System parts | PCI adapter                                                                                              |
| PCI adapter in slot 3  | PIOCARD<br>MASBUS<br>SLOTERR | Un-P2-C03                                        | Yes | System parts | PCI adapter                                                                                              |
| PCI adapter in slot 4  | PIOCARD<br>MASBUS<br>SLOTERR | Un-P2-C04                                        | Yes | System parts | PCI adapter                                                                                              |
| PCI adapter in slot 5  | PIOCARD<br>MASBUS<br>SLOTERR | Un-P2-C05                                        | Yes | System parts | PCI adapter                                                                                              |
| PCI adapter in slot 6  | PIOCARD<br>MASBUS<br>SLOTERR | Un-P2-C06                                        | Yes | System parts | PCI adapter                                                                                              |
| PCI adapter in slot 7  | PIOCARD<br>MASBUS<br>SLOTERR | Un-P2-C07                                        | Yes | System parts | PCI adapter                                                                                              |
| PCI adapter in slot 8  | PIOCARD<br>MASBUS<br>SLOTERR | Un-P2-C08                                        | Yes | System parts | PCI adapter                                                                                              |
| PCI adapter in slot 9  | PIOCARD<br>MASBUS<br>SLOTERR | Un-P2-C09                                        | Yes | System parts | PCI adapter                                                                                              |
| PCI adapter in slot 10 | PIOCARD<br>MASBUS<br>SLOTERR | Un-P2-C10                                        | Yes | System parts | PCI adapter                                                                                              |
|                        |                              |                                                  |     |              |                                                                                                          |

Service provider information

|                                                           |                                               |                                                  |     |              |                                                                                                          |
|-----------------------------------------------------------|-----------------------------------------------|--------------------------------------------------|-----|--------------|----------------------------------------------------------------------------------------------------------|
| PHB (PCI bridge set) 1                                    | BRDGSET<br>BRDGST1                            | Un-P2-C01<br>Un-P2-C02<br>Un-P2-C03<br>Un-P2-C04 |     |              | Replace the cards using the removal and replacement procedures corresponding to the locations indicated. |
| PHB (PCI bridge set) 2                                    | BRDGSET<br>BRDGST2                            | Un-P2-C05<br>Un-P2-C06<br>Un-P2-C07              |     |              |                                                                                                          |
| PHB (PCI bridge set) 3                                    | BRDGSET<br>BRDGST3                            | Un-P2-C08<br>Un-P2-C09<br>Un-P2-C10              |     |              |                                                                                                          |
| Fan 1 (left)                                              |                                               | Un-A1                                            | Yes | Power parts  | Removing and replacing parts in the 57/91, 57/94, and 406/1D expansion units                             |
| Fan 2                                                     |                                               | Un-A2                                            | Yes | Power parts  | Removing and replacing parts in the 57/91, 57/94, and 406/1D expansion units                             |
| Fan 3                                                     |                                               | Un-A3                                            | Yes | Power parts  | Removing and replacing parts in the 57/91, 57/94, and 406/1D expansion units                             |
| Fan 4 (right)                                             |                                               | Un-A4                                            | Yes | Power parts  | Removing and replacing parts in the 57/91, 57/94, and 406/1D expansion units                             |
| Power supply 1 (left)                                     |                                               | Un-E1                                            | Yes | System parts | Removing and replacing parts in the 57/91, 57/94, and 406/1D expansion units                             |
| UPIC connector (left)                                     |                                               | Un-E1-T1                                         |     |              |                                                                                                          |
| UPIC connector (right)                                    |                                               | Un-E1-T2                                         |     |              |                                                                                                          |
| Power supply 2 (right)                                    |                                               | Un-E2                                            | Yes | System parts | Removing and replacing parts in the 57/91, 57/94, and 406/1D expansion units                             |
| UPIC connector (left)                                     |                                               | Un-E2-T1                                         |     |              |                                                                                                          |
| UPIC connector (right)                                    |                                               | Un-E2-T2                                         |     |              |                                                                                                          |
| RIO adapter card connector port 0 (bottom connector - P0) | HSL_LNK<br>HSL2<br>HSL2_xx<br>HSLH<br>HSLH_xx | Un-P1-00                                         | Yes |              | Exchanging RIO cables                                                                                    |
| RIO adapter card connector port 1 (top connector - P1)    | HSL_LNK<br>HSL2<br>HSL2_xx<br>HSLH<br>HSLH_xx | Un-P1-01                                         | Yes |              | Exchanging RIO cables                                                                                    |
| RIO adapter card connector port 0 (bottom connector - P0) | HSL_LNK<br>HSL2<br>HSL2_xx<br>HSLH<br>HSLH_xx | Un-P2-00                                         | Yes |              | Exchanging RIO cables                                                                                    |

Service provider information

|                                                        |                                               |                                              |     |                 |                       |
|--------------------------------------------------------|-----------------------------------------------|----------------------------------------------|-----|-----------------|-----------------------|
| RIO adapter card connector port 1 (top connector - P1) | HSL_LNK<br>HSL2<br>HSL2_xx<br>HSLH<br>HSLH_xx | Un-P2-01                                     | Yes |                 | Exchanging RIO cables |
| Media subsystem power connector                        |                                               | Un-P1-T3                                     |     |                 |                       |
| Media subsystem power connector                        |                                               | Un-P2-T3                                     |     |                 |                       |
| Integrated SCSI controller port                        |                                               | Un-P1-T5                                     |     |                 |                       |
| Integrated SCSI controller port                        |                                               | Un-P1-T6                                     |     |                 |                       |
| Integrated SCSI controller port                        |                                               | Un-P2-T5                                     |     |                 |                       |
| Integrated SCSI controller port                        |                                               | Un-P2-T6                                     |     |                 |                       |
| Device physical locations                              |                                               |                                              |     |                 |                       |
| Disk drive 1                                           |                                               | Un-P3-D01<br>(logical location P2-T6-L8-L0)  |     | Disk unit parts | Disk drive            |
| Disk drive 2                                           |                                               | Un-P3-D02<br>(logical location P2-T6-L9-L0)  |     | Disk unit parts | Disk drive            |
| Disk drive 3                                           |                                               | Un-P3-D03<br>(logical location P2-T6-L10-L0) |     | Disk unit parts | Disk drive            |
| Disk drive 4                                           |                                               | Un-P3-D04<br>(logical location P2-T6-L11-L0) |     | Disk unit parts | Disk drive            |
| Disk drive 5                                           |                                               | Un-P4-D05<br>(logical location P2-T5-L8-L0)  |     | Disk unit parts | Disk drive            |
| Disk drive 6                                           |                                               | Un-P4-D06<br>(logical location P2-T5-L9-L0)  |     | Disk unit parts | Disk drive            |
| Disk drive 7                                           |                                               | Un-P4-D07<br>(logical location P2-T5-L10-L0) |     | Disk unit parts | Disk drive            |
| Disk drive 8                                           |                                               | Un-P4-D08<br>(logical                        |     | Disk unit parts | Disk drive            |

Service provider information

|               |  |                                                    |  |                    |            |
|---------------|--|----------------------------------------------------|--|--------------------|------------|
|               |  | location<br>P2-T5-L11-L0)                          |  |                    |            |
| Disk drive 9  |  | Un-P5-D09<br>(logical<br>location<br>P1-T6-L8-L0)  |  | Disk unit<br>parts | Disk drive |
| Disk drive 10 |  | Un-P5-D10<br>(logical<br>location<br>P1-T6-L9-L0)  |  | Disk unit<br>parts | Disk drive |
| Disk drive 11 |  | Un-P5-D11<br>(logical<br>location<br>P1-T6-L10-L0) |  | Disk unit<br>parts | Disk drive |
| Disk drive 12 |  | Un-P5-D12<br>(logical<br>location<br>P1-T6-L11-L0) |  | Disk unit<br>parts | Disk drive |
| Disk drive 13 |  | Un-P6-D13<br>(logical<br>location<br>P1-T5-L8-L0)  |  | Disk unit<br>parts | Disk drive |
| Disk drive 14 |  | Un-P6-D14<br>(logical<br>location<br>P1-T5-L9-L0)  |  | Disk unit<br>parts | Disk drive |
| Disk drive 15 |  | Un-P6-D15<br>(logical<br>location<br>P1-T5-L10-L0) |  | Disk unit<br>parts | Disk drive |
| Disk drive 16 |  | Un-P6-D16<br>(logical<br>location<br>P1-T5-L11-L0) |  | Disk unit<br>parts | Disk drive |

**Note:**

- The following table provides information necessary to identify the IOP to which an IOA is assigned.
  - ◆ The left column indicates the domain in which IOA assignment is allowed.
  - ◆ The right column is used to determine the IOP to which an IOA is assigned.
  - ◆ The first position in the list must be an IOP. The remaining positions may be IOPs or IOAs. IOAs are assigned to the first IOP located to their left in the list. Although IOAs can be manually reassigned using SST/DST, the IOA assignments return to the default order after each IPL.

Table 2. Identify the IOP to which IOAs are assigned

| Multi-adapter bridge domain / PCI<br>bridge set | IOA assignment rules   |
|-------------------------------------------------|------------------------|
| P1-C01 through P1-C04                           | P1-C02, P1-C03, P1-C04 |
| P1-C05 through P1-C07                           | P1-C06, P1-C07         |
| P2-C01 through P2-C04                           | P2-C02, P2-C03, P2-C04 |
| P2-C05 through P2-C07                           | P2-C06, P2-C07         |

**Parent topic:** [Finding part locations](#)

## Locations 57/95 expansion unit

The following figures show locations for devices installed in the 57/95 expansion unit, and the SCSI IDs for the media devices.

**Note:** The SCSI IDs shown for the media devices indicate how installed devices are set when shipped from the factory.

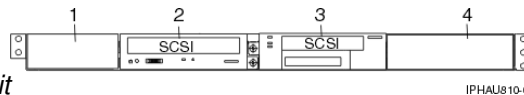


Figure 1. Front view of the 57/95 expansion unit

| Index | Description                        | Location code  |
|-------|------------------------------------|----------------|
| 1     | Filler plate                       |                |
| 2     | DVD media device, SCSI address 05  | Un-Px-Ty-L5-L0 |
| 3     | Tape media device, SCSI address 06 | Un-Px-Ty-L6-L0 |
| 4     | Filler plate                       |                |

Where:

- Un-Px is the backplane of the unit where the SCSI PCI adapter is installed.
- Ty is the connector on the SCSI PCI adapter.

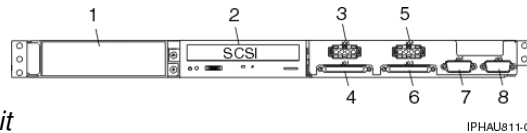


Figure 2. Back view of the 57/95 expansion unit

| Index | Description                                   | Location code  |
|-------|-----------------------------------------------|----------------|
| 1     | Filler plate                                  |                |
| 2     | DVD media device, SCSI address 06             | Un-Px-Ty-L6-L0 |
| 3     | SCSI power connection for front media devices |                |
| 4     | SCSI data connection for front media devices  |                |
| 5     | SCSI power connection for back media devices  |                |
| 6     | SCSI data connection for back media devices   |                |
| 7     | Reserved                                      |                |
| 8     | Reserved                                      |                |

Where:

- Un-Px is the backplane of the unit where the SCSI PCI adapter is installed.
- Ty is the connector on the SCSI PCI adapter.

**Parent topic:** [Finding part locations](#)

## Locations 11D/10, 11D/11, and 57/90 expansion units

**Note:** The known logical location codes for this unit are listed next to the corresponding physical location in the following information. If you are working with a logical location code for this unit and it is not listed in the following information, contact your next level of support.

The following diagrams show the field replaceable unit (FRU) layout in the 11D/11 and 57/90 expansion units. Use them with the following tables.

The following diagrams also show the field replaceable unit (FRU) layout in the 11D/10 expansion unit. After you locate your part in the 11D/10 expansion unit, refer to the [11D/10 service guide](#) for part number information and the removal and replacement procedures.

**Note:** Some units may have labels that designate location codes other than those shown in the following illustrations and tables. If that is the case, use the location codes shown in the following illustrations and tables.

Figure 1. Front view of the expansion unit

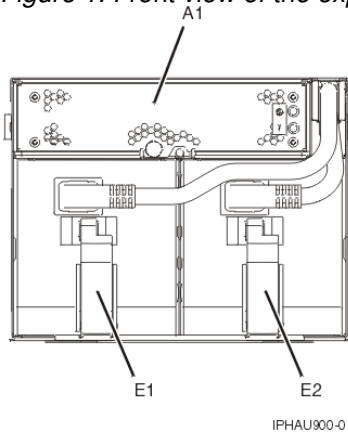
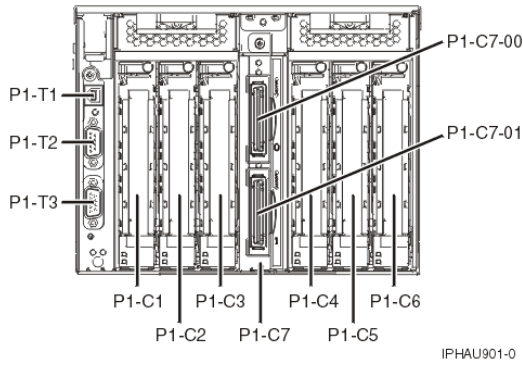


Figure 2. Back view of the expansion unit





The following table gives the components available for callout on the 11D/11 and 57/90 expansion units. It matches those components with the FRU containing the component. The other columns give location information, a link to a removal and replacement procedure, and additional information.

**Attention:** After replacing any part on a server or expansion unit, perform [Verifying the repair](#).

Table 1. FRU locations and failing components

| Failing item name          | Symbolic failing item name   | Physical location code | Identify LED | Link to part number                    | Failing item removal and replacement procedures                      |
|----------------------------|------------------------------|------------------------|--------------|----------------------------------------|----------------------------------------------------------------------|
| Expansion unit             |                              | <i>Un</i>              |              |                                        |                                                                      |
| <b>Fan</b>                 |                              |                        |              |                                        |                                                                      |
| Fan                        |                              | <i>Un-A1</i>           | Yes          | <a href="#">Part assembly diagrams</a> | <a href="#">Exchange the 11D/11 and 57/90 fan assembly</a>           |
| <b>Power supplies</b>      |                              |                        |              |                                        |                                                                      |
| Power supply 1             |                              | <i>Un-E1</i>           | Yes          | <a href="#">Power parts</a>            | <a href="#">Exchange the 11D/11 and 57/90 power supply</a>           |
| Power supply 2             |                              | <i>Un-E2</i>           | Yes          | <a href="#">Power parts</a>            | <a href="#">Exchange the 11D/11 and 57/90 power supply</a>           |
| <b>Backplane</b>           |                              |                        |              |                                        |                                                                      |
| I/O backplane              | MA_BRDG<br>TWRPLNR           | <i>Un-P1</i>           | Yes          | <a href="#">282A, 28BB</a>             | <a href="#">Exchange the 11D/11 and 57/90 I/O backplane assembly</a> |
| <b>I/O backplane ports</b> |                              |                        |              |                                        |                                                                      |
| Rack beacon connector      |                              | <i>Un-P1-T1</i>        |              |                                        |                                                                      |
| <b>Adapters</b>            |                              |                        |              |                                        |                                                                      |
| PCI adapter in slot 1      | PIOCARD<br>MASBUS<br>SLOTERR | <i>Un-P1-C1</i>        | Yes          | <a href="#">System parts</a>           | <a href="#">PCI adapter</a>                                          |
| PCI adapter in slot 2      | PIOCARD<br>MASBUS<br>SLOTERR | <i>Un-P1-C2</i>        | Yes          | <a href="#">System parts</a>           | <a href="#">PCI adapter</a>                                          |

Service provider information

|                                                               |                                               |                                           |     |              |                                                                                                                            |
|---------------------------------------------------------------|-----------------------------------------------|-------------------------------------------|-----|--------------|----------------------------------------------------------------------------------------------------------------------------|
| PCI adapter in slot 3                                         | PIOCARD<br>MASBUS<br>SLOTERR                  | Un-P1-C3                                  | Yes | System parts | PCI adapter                                                                                                                |
| PCI adapter in slot 4                                         | PIOCARD<br>MASBUS<br>SLOTERR                  | Un-P1-C4                                  | Yes | System parts | PCI adapter                                                                                                                |
| PCI adapter in slot 5                                         | PIOCARD<br>MASBUS<br>SLOTERR                  | Un-P1-C5                                  | Yes | System parts | PCI adapter                                                                                                                |
| PCI adapter in slot 6                                         | PIOCARD<br>MASBUS<br>SLOTERR                  | Un-P1-C6                                  | Yes | System parts | PCI adapter                                                                                                                |
| PCI bridge set 1                                              | BRDGST1                                       | Un-P1<br>Un-P1-C1<br>Un-P1-C2<br>Un-P1-C3 |     |              | Replace the I/O backplane and cards using the removal and replacement procedures corresponding to the locations indicated. |
| PCI bridge set 2                                              | BRDGST2                                       | Un-P1<br>Un-P1-C4<br>Un-P1-C5<br>Un-P1-C6 |     |              | Replace the I/O backplane and cards using the removal and replacement procedures corresponding to the locations indicated. |
| RIO adapter<br>• HSL I/O adapter<br>• RIO host bridge adapter | SIIOADP<br>SIADPCD<br>SI_PHB                  | Un-P1-C7                                  | Yes | 28FF         | RIO card                                                                                                                   |
| RIO adapter connector (top connector)                         | HSL_LNK<br>HSL2<br>HSL2_xx<br>HSLH<br>HSLH_xx | Un-P1-C7-00                               | Yes |              | Exchanging RIO cables                                                                                                      |
| RIO adapter connector                                         | HSL_LNK<br>HSL2<br>HSL2_xx<br>HSLH<br>HSLH_xx | Un-P1-C7-01                               | Yes |              | Exchanging RIO cables                                                                                                      |

Parent topic: [Finding part locations](#)

## Part assembly diagrams for 11D/11 and 57/90 expansion units

**Note:** For 11D/10 part number information, see [11D/10 service guide](#) .

**Final assembly for 11D/11 and 57/90**

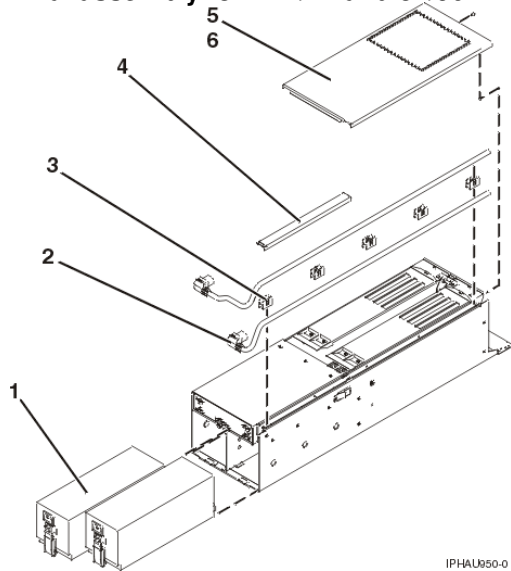


Table 1. Final assembly part numbers for 11D/11 and 57/90

| Index number | Part number                             | Units | Description                |
|--------------|-----------------------------------------|-------|----------------------------|
| 1            | See <a href="#">Part number catalog</a> | 2     | Power supply               |
| 2            | See <a href="#">Part number catalog</a> | 2     | Cable, power               |
| 3            | 09P3185                                 | 5     | Guide, power cable         |
| 4            | 80P2654                                 | 1     | Cover, power cable channel |
| 5            | 80P2646                                 | 1     | Access cover               |
| 6            | 1624743                                 | 2     | Screw, access cover        |

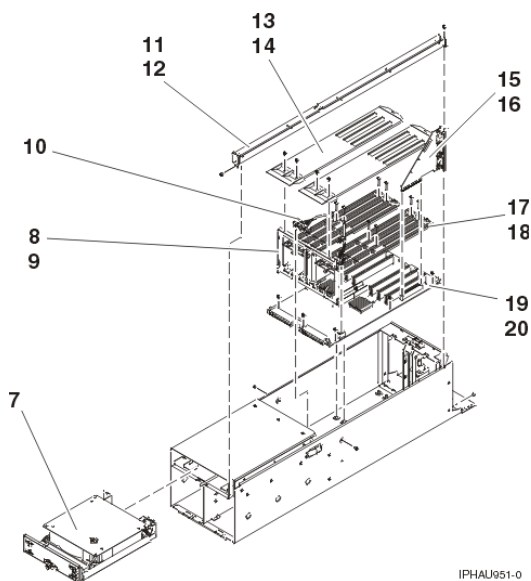


Table 2. Final assembly for 11D/11 and 57/90, continued

| Index number | Part number | Units | Description |
|--------------|-------------|-------|-------------|
|--------------|-------------|-------|-------------|

Service provider information

|    |                                         |   |                                                       |
|----|-----------------------------------------|---|-------------------------------------------------------|
| 7  | 03N6069                                 | 1 | Fan assembly                                          |
| 8  | 80P2645                                 | 1 | Bracket, bulkhead                                     |
| 9  | 1621829                                 | 2 | Screw, bulkhead bracket                               |
| 10 | 03N6196                                 | 1 | Cable, fan                                            |
| 11 | 80P2648                                 | 1 | Tray, power cable                                     |
| 12 | 1621829                                 | 2 | Screw, tray mounting                                  |
| 13 | 80P2648                                 | 2 | Guide, upper                                          |
| 14 | 1621829                                 | 4 | Screw, upper guide mounting                           |
| 15 | NONUM                                   |   | SPCN connector card (included with index number 20)   |
| 16 | NONUM                                   |   | Screw (included with index number 20)                 |
| 17 | 80P2666                                 | 2 | Guide, lower                                          |
| 18 | 1624749                                 | 8 | Screw, lower guide mounting                           |
| 19 | See <a href="#">Part number catalog</a> | 1 | I/O backplane assembly (includes SPCN connector card) |
| 20 | 1624743                                 | 6 | Screw, backplane mounting                             |

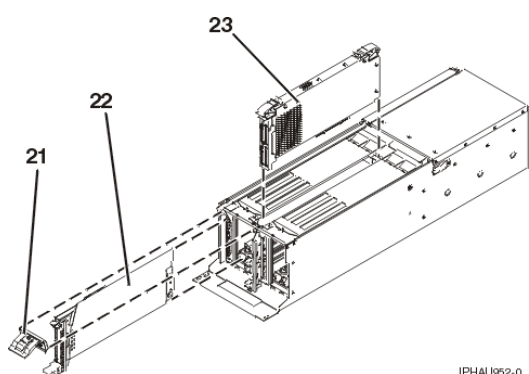


Table 3. Final assembly for 11D/11 and 57/90, continued

| Index number | Part number                             | Units | Description  |
|--------------|-----------------------------------------|-------|--------------|
| 21           | 80P2669                                 | 2     | Filler, EMC  |
| 22           | 21P8331                                 | AR    | PCI cassette |
| 23           | See <a href="#">Part number catalog</a> | 1     | RIO card     |

**Rack mounting enclosure for 11D/11 and 57/90**

Table 4. Rack mounting enclosure part numbers for 11D/11 and 57/90

| Index number | Part number | Units | Description                                  |
|--------------|-------------|-------|----------------------------------------------|
|              | 09P5159     | 1     | Front cover                                  |
|              | 04N6587     | 2     | Thumbscrew, shipping                         |
|              | NONUM       | 1     | Two-position I/O subsystem mounting assembly |
|              | 1624779     | 4     | Screw, I/O subsystem mounting                |
|              | 39J4471     | 1     | Left rail                                    |

Service provider information

|  |         |    |                                           |
|--|---------|----|-------------------------------------------|
|  | 03N3847 | 1  | Right rail                                |
|  | 1624779 | 8  | Screw, rail mounting                      |
|  | 74F1823 | 12 | Nut clip, rail mounting                   |
|  | 80P2665 | 2  | Cable support bracket                     |
|  | 00G1268 | 2  | Screw, bracket mounting                   |
|  | 80P2663 | 2  | I/O subsystem retention bracket           |
|  | 93H4729 | 2  | Screw, expansion unit attach              |
|  | 93H4729 | 2  | Screw, I/O subsystem attach               |
|  | 80P2664 | 1  | Back filler for empty I/O subsystem space |
|  | 93H4729 | 2  | Screw, filler mounting                    |

Parent topic: [Part assembly diagrams](#)

---

## Exchange the 11D/11 and 57/90 fan assembly

To remove the fan assembly, do the following:

1. This procedure can be done with the power on.
2. Locate the fan assembly on the front of the expansion unit.
3. Unscrew the thumbscrew that holds the fan into the expansion unit.
4. Pull the fan assembly straight out until it is clear of the expansion unit.
5. To replace the fan assembly, reverse this removal procedure.

Parent topic: [Removing and replacing parts in the 11D/11 and 57/90 expansion units](#)

---

## Exchange the 11D/11 and 57/90 power supply

To remove the power supply, do the following:

**Attention:** Do not remove two power supplies at the same time if performing an exchange with power on. Power supplies are considered as replaceable with power on only if you remove one power supply at a time. The power supplies can be removed from the front of the expansion unit.

1. Disconnect the power cord from the power supply.
2. Unlatch the power supply handle and rotate the handle downward to unseat the power supply.

**Attention:** Do not remove a power supply for more than four minutes. If you cannot replace the power supply in less than four minutes, shut down the system and then remove the power supply.

3. Pull the power supply straight out from the expansion unit.
4. To replace the power supply, reverse this removal procedure.

**Parent topic:** [Removing and replacing parts in the 11D/11 and 57/90 expansion units](#)

---

## Exchange the 11D/11 and 57/90 I/O backplane assembly

**Note:** The I/O backplane and the SPCN riser card are replaced as a pair.

Use this procedure in conjunction with [Powering off an expansion unit](#) to remove or replace the I/O backplane assembly on 11D/11 and 57/90 expansion units.

1. Power off the expansion unit (see [Powering off an expansion unit](#)).
2. Remove the ac power cord from the expansion unit that you are working on.
3. Put the I/O subsystem into the service position. (See [Place the 11D/11 and 57/90 expansion unit in the service position](#)).
4. Label and remove the PCI adapters. (See [PCI adapter](#)).
5. Remove the service access cover. (See [Remove the 11D/11 and 57/90 expansion unit service access cover](#)).
6. Remove the power supplies. (See [Exchange the 11D/11 and 57/90 power supply](#)).
7. Remove the RIO bus adapter. (See [Exchange the 11D/11 and 57/90 RIO card](#)).
8. Remove the screws that hold the line cord tray.
9. Remove the line cord tray.
10. Remove the two screws that hold the SPCN connector card
11. Remove the SPCN connector card from the I/O backplane.
12. Remove the screws that hold the upper PCI adapter-mounting guides, and remove the guides.
13. Remove the screws that hold the lower PCI adapter-mounting guides, and remove the guides.
14. Remove the screws from the bulkhead bracket.
15. Disconnect the fan cable from the bulkhead bracket.
16. Remove the bulkhead bracket.
17. Disconnect the fan cable from the I/O backplane.
18. Remove the screws that secure the I/O backplane to the subsystem chassis.
19. Lift up on the rear of the backplane and slide it towards the rear of the unit, enough to clear the pipe light. Then lift the backplane up and out of the subsystem chassis.
20. Install the new backplane by reversing the above procedure.
21. Perform [Setting expansion unit configuration ID and MTMS value](#) and then continue with the next step of this procedure.
22. Go to [Verifying the repair](#). This ends the procedure.

**Parent topic:** [Removing and replacing parts in the 11D/11 and 57/90 expansion units](#)

---

## Exchange the 11D/11 and 57/90 RIO card

Use this procedure in conjunction with [Powering off an expansion unit](#) to remove or replace the RIO card on 11D/11 and 57/90 expansion units.

To remove the RIO card, do the following:

1. Power off the expansion unit (see [Powering off an expansion unit](#)).
2. Remove the ac power cord from the expansion unit that you are working on.
3. Put the expansion unit into the service position. (See [Place the 11D/11 and 57/90 expansion unit in the service position](#)).
4. Remove the service access cover. (See [Remove the 11D/11 and 57/90 expansion unit service access cover](#)).
5. Remove the screws that attach the RIO card to the expansion unit chassis.
6. Carefully pull the RIO card straight up and out of the slot.
7. To replace the RIO card, reverse this removal procedure.

**Parent topic:** [Removing and replacing parts in the 11D/11 and 57/90 expansion units](#)

---

## Locations 11D/20 expansion unit

**Note:** The known logical location codes for this unit are listed next to the corresponding physical location in the following information. If you are working with a logical location code for this unit and it is not listed in the following information, contact your next level of support.

The following diagrams show field replaceable unit (FRU) layout in the 11D/20 expansion units. Use these diagrams with the following tables.

**Note:** Some units may have labels that designate location codes other than those shown in the following illustrations and tables. If that is the case, use the location codes shown in the following illustrations and tables.

*Figure 1. Front view of the 11D/20 expansion unit*

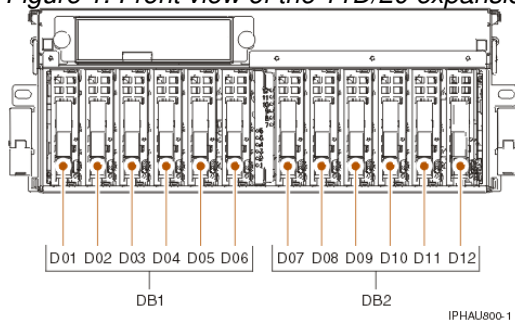


Figure 2. Back view of the 11D/20 expansion unit

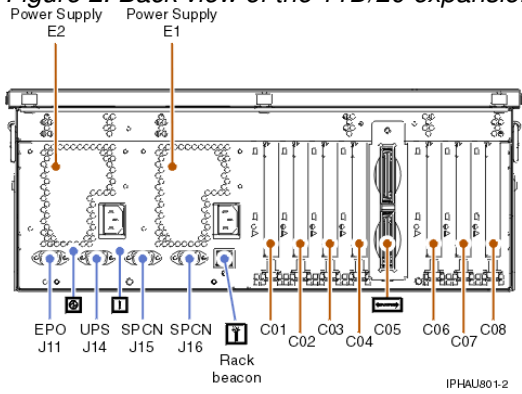
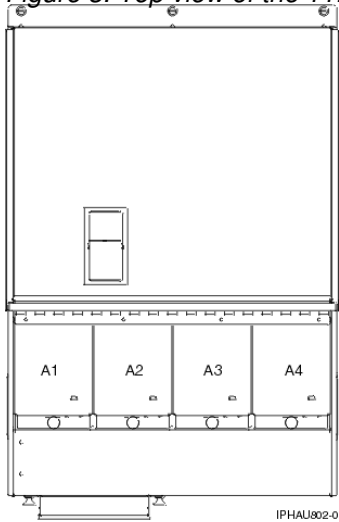


Figure 3. Top view of the 11D/20 expansion unit



The following table gives the components available for callout on the 11D/20 expansion units. It matches those components with the FRU containing the component. The other columns give location information, a link to a removal and replacement procedure, and additional information.

**Attention:** After replacing any part on a server or expansion unit, perform [Verifying the repair](#).

Table 1. FRU locations and failing components for 11D/20 expansion unit

| Failing item name | Symbolic failing item name                         | Physical location code | Identify LED | Link to part number  | Failing item removal and replacement procedures |
|-------------------|----------------------------------------------------|------------------------|--------------|----------------------|-------------------------------------------------|
| Backplane         | TWRCARD<br>MA_BRDG<br>• SPCN<br>MABRCFG<br>PPCITWR | U $n$ -P1              | Yes          | <a href="#">28BE</a> | <a href="#">I/O backplane assembly</a>          |



Service provider information

|                                                                                                                    |                                                                                                                                                          |                                                           |     |  |                                                                                                                               |
|--------------------------------------------------------------------------------------------------------------------|----------------------------------------------------------------------------------------------------------------------------------------------------------|-----------------------------------------------------------|-----|--|-------------------------------------------------------------------------------------------------------------------------------|
| <ul style="list-style-type: none"> <li>• Card enclosure or backplane</li> <li>• Multi-bridge (all)</li> </ul>      | <ul style="list-style-type: none"> <li>• PRI_PCI</li> <li>• HSL_LNK</li> <li>• PIOCARD</li> <li>• MASBUS</li> <li>• TWRKPL</li> <li>• TWRPLNR</li> </ul> |                                                           |     |  |                                                                                                                               |
| PCI adapter in slot 1                                                                                              | PIOCARD<br>MASBUS<br>SLOTERR                                                                                                                             | Un-P1-C01                                                 | Yes |  | PCI adapter                                                                                                                   |
| PCI adapter in slot 2                                                                                              | PIOCARD<br>MASBUS<br>SLOTERR                                                                                                                             | Un-P1-C02                                                 | Yes |  | PCI adapter                                                                                                                   |
| PCI adapter in slot 3                                                                                              | PIOCARD<br>MASBUS<br>SLOTERR                                                                                                                             | Un-P1-C03                                                 | Yes |  | PCI adapter                                                                                                                   |
| PCI adapter in slot 4                                                                                              | PIOCARD<br>MASBUS<br>SLOTERR                                                                                                                             | Un-P1-C04                                                 | Yes |  | PCI adapter                                                                                                                   |
| RIO adapter <ul style="list-style-type: none"> <li>• HSL I/O adapter</li> <li>• RIO host bridge adapter</li> </ul> | SIIOADP<br>SIADPCD<br>SI_PHB                                                                                                                             | Un-P1-C05                                                 | Yes |  | RIO card                                                                                                                      |
| PCI adapter in slot 6                                                                                              | PIOCARD<br>MASBUS<br>SLOTERR                                                                                                                             | Un-P1-C06                                                 | Yes |  | PCI adapter                                                                                                                   |
| PCI adapter in slot 7                                                                                              | PIOCARD<br>MASBUS<br>SLOTERR                                                                                                                             | Un-P1-C07                                                 | Yes |  | PCI adapter                                                                                                                   |
| PCI adapter in slot 8                                                                                              | PIOCARD<br>MASBUS<br>SLOTERR                                                                                                                             | Un-P1-C08                                                 | Yes |  | PCI adapter                                                                                                                   |
| PCI bridge set 1                                                                                                   | BRDGSET<br>BRDGST1                                                                                                                                       | Un-P1<br>Un-P1-C01<br>Un-P1-C02<br>Un-P1-C03<br>Un-P1-C04 |     |  | Replace the system backplane and cards using the removal and replacement procedures corresponding to the locations indicated. |
| PCI bridge set 2                                                                                                   | BRDGSET<br>BRDGST2                                                                                                                                       | Un-P1<br>Un-P1-C06<br>Un-P1-C07<br>Un-P1-C08              |     |  | Replace the system backplane and cards using the removal and replacement procedures corresponding to the locations indicated. |
| EPO connector (J11)                                                                                                |                                                                                                                                                          | Un-P1-T1                                                  |     |  |                                                                                                                               |
| UPS connector (J14)                                                                                                |                                                                                                                                                          | Un-P1-T2                                                  |     |  |                                                                                                                               |
| SPCN connector (J15)                                                                                               |                                                                                                                                                          | Un-P1-T3                                                  |     |  |                                                                                                                               |
|                                                                                                                    |                                                                                                                                                          | Un-P1-T4                                                  |     |  |                                                                                                                               |

Service provider information

|                                          |                                               |              |     |                                        |                                       |
|------------------------------------------|-----------------------------------------------|--------------|-----|----------------------------------------|---------------------------------------|
| SPCN connector (J16)                     |                                               |              |     |                                        |                                       |
| Rack beacon connector                    |                                               | Un-P1-T5     |     |                                        |                                       |
| Fan 1                                    |                                               | Un-A1        | Yes | <a href="#">Part assembly diagrams</a> | Fan                                   |
| Fan 2                                    |                                               | Un-A2        | Yes | <a href="#">Part assembly diagrams</a> | Fan                                   |
| Fan 3                                    |                                               | Un-A3        | Yes | <a href="#">Part assembly diagrams</a> | Fan                                   |
| Fan 4                                    |                                               | Un-A4        | Yes | <a href="#">Part assembly diagrams</a> | Fan                                   |
| <b>Device physical locations</b>         |                                               |              |     |                                        |                                       |
| Disk drive 1                             |                                               | Un-DB1-D01   |     | <a href="#">Disk unit parts</a>        | Disk drive                            |
| Disk drive 2                             |                                               | Un-DB1-D02   |     | <a href="#">Disk unit parts</a>        | Disk drive                            |
| Disk drive 3                             |                                               | Un-DB1-D03   |     | <a href="#">Disk unit parts</a>        | Disk drive                            |
| Disk drive 4                             |                                               | Un-DB1-D04   |     | <a href="#">Disk unit parts</a>        | Disk drive                            |
| Disk drive 5                             |                                               | Un-DB1-D05   |     | <a href="#">Disk unit parts</a>        | Disk drive                            |
| Disk drive 6                             |                                               | Un-DB1-D06   |     | <a href="#">Disk unit parts</a>        | Disk drive                            |
| Disk drive 7                             |                                               | Un-DB2-D07   |     | <a href="#">Disk unit parts</a>        | Disk drive                            |
| Disk drive 8                             |                                               | Un-DB2-D08   |     | <a href="#">Disk unit parts</a>        | Disk drive                            |
| Disk drive 9                             |                                               | Un-DB2-D09   |     | <a href="#">Disk unit parts</a>        | Disk drive                            |
| Disk drive 10                            |                                               | Un-DB2-D10   |     | <a href="#">Disk unit parts</a>        | Disk drive                            |
| Disk drive 11                            |                                               | Un-DB2-D11   |     | <a href="#">Disk unit parts</a>        | Disk drive                            |
| Disk drive 12                            |                                               | Un-DB2-D12   |     | <a href="#">Disk unit parts</a>        | Disk drive                            |
| Power supply 1                           |                                               | Un-E1        |     | <a href="#">Power parts</a>            | Power supply                          |
| Power supply 2                           |                                               | Un-E2        |     | <a href="#">Power parts</a>            | Power supply                          |
| Disk drive backplane                     |                                               | Un-DB1       |     | <a href="#">Backplanes</a>             | Disk drive backplane                  |
| Disk drive backplane                     |                                               | Un-DB2       |     | <a href="#">Backplanes</a>             | Disk drive backplane                  |
| RIO adapter connector (bottom connector) | HSL_LNK<br>HSL2<br>HSL2_xx<br>HSLH<br>HSLH_xx | Un-P1-C05-00 | Yes |                                        | <a href="#">Exchanging RIO cables</a> |
| RIO adapter connector                    | HSL_LNK<br>HSL2<br>HSL2_xx<br>HSLH<br>HSLH_xx | Un-P1-C05-01 | Yes |                                        | <a href="#">Exchanging RIO cables</a> |

**Notes:**

1. J11 is an RPO connection, J14 is an uninterruptible power supply connector, J15 is an SPCN 1 connector, and J16 is an SPCN 2 connector.
2. Multi-adapter bridge domains are labeled PCI Bridge Set inside the expansion unit.
3. The following table provides information necessary to identify the IOP to which an IOA is assigned.
  - ◆ The left column indicates the domain in which IOA assignment is allowed.
  - ◆ The right column is used to determine the IOP to which an IOA is assigned.

- ◆ The first position in the list must be an IOP. The remaining positions may be IOPs or IOAs. IOAs are assigned to the first IOP located to their left in the list. Although IOAs can be manually reassigned using SST/DST, the IOA assignments return to the default order after each IPL.

Table 2. Identify the IOP to which IOAs are assigned

| Multi-adapter bridge domain / PCI bridge set | IOA assignment rules |
|----------------------------------------------|----------------------|
| C01 - C04                                    | C01, C02, C03, C04   |
| C06 - C08                                    | C06, C07, C08        |

Parent topic: [Finding part locations](#)

## Part assembly diagrams for 11D/20 expansion unit

### I/O backplane and cabling assembly for 11D/20

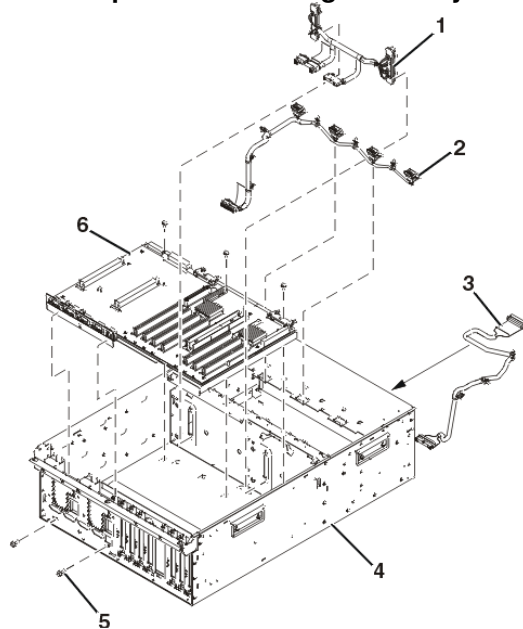


Table 1. I/O backplane and cabling assembly part numbers for 11D/20

| Index number | Part number                         | Units | Description               |
|--------------|-------------------------------------|-------|---------------------------|
| 1            | 53P0416                             | 1     | DASD cable                |
| 2            | 53P4065                             | 1     | Blower cable              |
| 3            | 53P0414                             | 1     | Control panel cable       |
| 4            | 53P0220                             | 1     | Chassis assembly          |
| 5            | 44H7366                             | 5     | Mounting screw, stiffener |
| 6            | See <a href="#">Backplane parts</a> | 1     | I/O Backplane             |

**PCI adapters assembly for 11D/20**

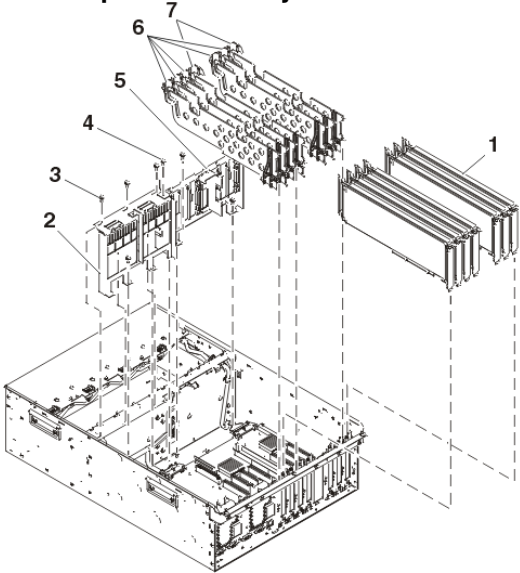


Table 2. PCI adapters assembly part numbers for 11D/20

| Index number | Part number                      | Units                | Description                    |
|--------------|----------------------------------|----------------------|--------------------------------|
| 1            | See <a href="#">System parts</a> | 7 (maximum quantity) | PCI adapter                    |
| 2            | 39J1118                          | 1                    | Power supply bulkhead          |
| 3            | 44H7366                          | 4                    | Screw, power bulkhead mounting |
| 4            | 44H7366                          | 3                    | Screw, PCI plate mounting      |
| 5            | 53P0249                          | 1                    | PCI adapter headstock bracket  |
| 6            | 53P2728                          | 5                    | PCI dividers                   |
| 7            | 53P2729                          | 2                    | PCI dividers                   |

**Power, RIO adapter, and cabling assembly for 11D/20**

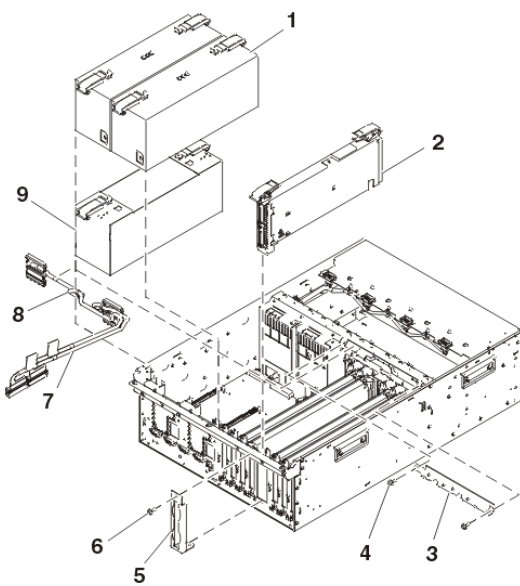


Table 3. Power, RIO adapter, and cabling assembly part numbers for 11D/20

| Index number | Part number                      | Units                   | Description                |
|--------------|----------------------------------|-------------------------|----------------------------|
| 1            | See <a href="#">Power parts</a>  | 2 (maximum quantity)    | Power supply               |
| 2            | See <a href="#">System parts</a> | 1                       | RIO bus adapter            |
|              | See <a href="#">System parts</a> | 1                       | RIO-2 bus adapter          |
| 3            | 53P2690                          | 3                       | Cable bracket, SCSI        |
| 4            | 44H7366                          | 1                       | Screw, SCSI cable          |
| 5            | 39J3287                          | 5                       | RIO-2 cable bracket        |
| 6            | 44H7366                          | 2                       | Screw, RIO-2 cable bracket |
| 7            | 53P0417                          | Configuration dependent | SCSI bus cable             |
| 8            | 53P0418                          | Configuration dependent | SCSI bus cable             |
| 9            | 39J1175                          | 1                       | Power supply filler        |

## Operator panel assembly for 11D/20

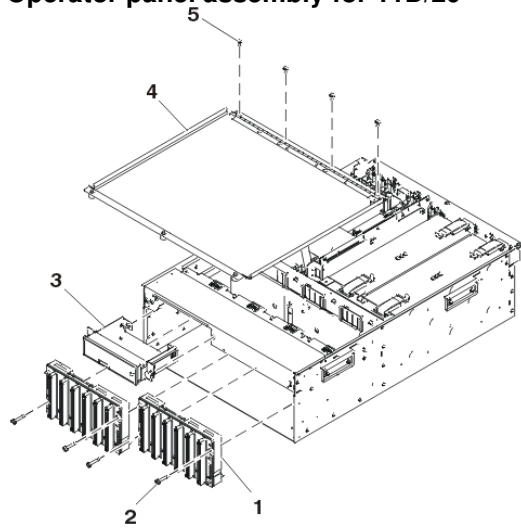


Table 4. Operator panel assembly part numbers for 11D/20

| Index number | Part number                             | Units | Description                                          |
|--------------|-----------------------------------------|-------|------------------------------------------------------|
| 1            | See <a href="#">Disk unit parts</a>     | 2     | Disk-drive-backplane (disk drive enclosure included) |
| 2            | 53P0321                                 | 4     | Screw, disk-drive-backplane mounting                 |
| 3            | See <a href="#">Control panel parts</a> | 1     | Operator panel                                       |
| 4            | 39J1178                                 | 1     | Processor cover                                      |
| 5            | 44H7366                                 | 4     | Screw, cover-mounting                                |

**Fans and disk drives assembly for 11D/20**

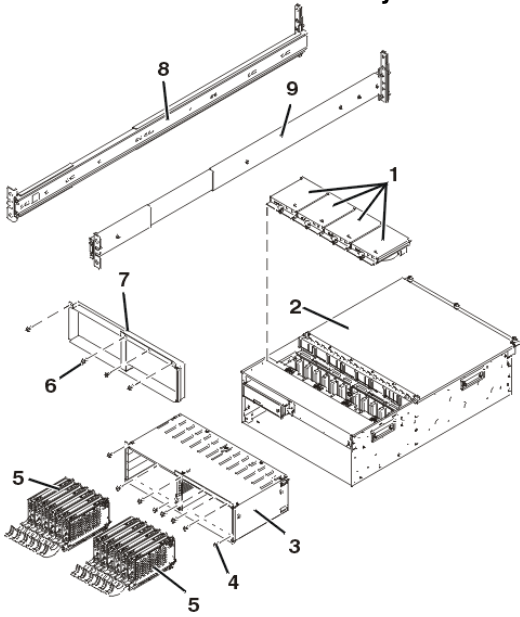


Table 5. Fans and disk drives assembly part numbers for 11D/20

| Index number | Part number                         | Units        | Description                                                   |
|--------------|-------------------------------------|--------------|---------------------------------------------------------------|
| 1            | 39J1176                             | 4            | Fan assembly                                                  |
| 2            | NONUM                               |              | 11D/20                                                        |
| 3            | 53P0257                             | 1            | Disk-drive enclosure 12 pack (disk drive backplanes included) |
| 4            | 53P0319                             | 8            | Screw, disk drive enclosure mounting                          |
| 5            | See <a href="#">Disk unit parts</a> |              | Disk drives                                                   |
| 6            | 53P0234                             | 4            | Screw, filler-plate mounting                                  |
| 7            | 44H7366                             | 1 (optional) | Disk drive filler plate                                       |
| 8            | 42R5254                             | 1            | Left rail                                                     |
| 9            | 42R5255                             | 1            | Right rail                                                    |

**Covers and brackets assembly for 11D/20**

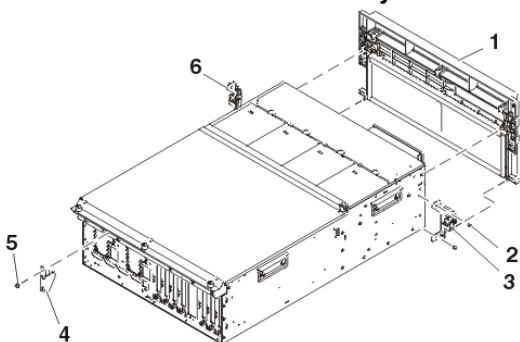


Table 6. Covers and brackets assembly part numbers for 11D/20

| Index number | Part number | Units | Description                  |
|--------------|-------------|-------|------------------------------|
| 1            | 39J3326     | 1     | Front bezel                  |
| 2            | 44H7366     | 2     | Screw, latch bracket         |
| 3            | 53P2572     | 1     | Latch bracket assembly left  |
| 4            | 42R4299     | 4     | Cable arm bracket            |
| 5            | 44H7366     | 1     | Screw, cable arm bracket     |
| 6            | 53P2573     | 1     | Latch bracket assembly right |

Parent topic: [Part assembly diagrams](#)

---

## Using the product activity log

This procedure can help you learn how to use the Product Activity Log (PAL).

1. To locate a problem, find an entry in the product activity log for the symptom you are seeing.
  - a. On the command line, enter the Start System Service Tools command:

```
STRSST
```

If you cannot get to SST, select DST. See [Dedicated Service Tools \(DST\)](#) for details.

**Note:** Do not IPL the system or partition to get to DST.

- b. On the Start Service Tools Sign On display, type in a User ID with service authority and password.
- c. From the System Service Tools display, select Start a Service Tool > Product activity log > Analyze log.
- d. On the Select Subsystem Data display, select the option to view All Logs.

**Note:** You can change the From: and To: Dates and Times from the 24-hour default if the time that the customer reported having the problem was more than 24 hours ago.

- e. Use the defaults on the Select Analysis Report Options display by pressing the Enter key.
- f. Search the entries on the Log Analysis Report display.

**Note:** For example, a 6380 Tape Unit error would be identified as follows:

```

◇ System Reference Code: 6380CC5F
◇ Class: Perm
◇ Resource Name: TAP01

```

2. Find an SRC from the product activity log that best matches the time and type of the problem the customer reported.

Did you find an SRC that matches the time and type of problem the customer reported?

- ◆ Yes: Go to [Reference codes](#) and use the SRC information to correct the problem. This ends the procedure.
- ◆ No: Contact your next level of support. This ends the procedure.

## Using the problem log

Use this procedure to find and analyze a problem log entry that relates to the problem reported.

**Note:** For on-line problem analysis (WRKPRB), ensure that you are logged on with QSRV authority. During problem isolation, this will allow access to test procedures that are not available under any other log-on.

1. On the command line, enter the Work with Problems command:

```
WRKPRB
```

**Note:** Use F4 to change the WRKPRB parameters to select and sort on specific problem log entries that match the problem. Also, F11 displays the dates and times the problems were logged by the system.

Was an entry that relates to the problem found?

**Note:** If the WRKPRB function was not available answer NO.

- ◆ Yes: Continue with the next step.
  - ◆ No: Go to [Problems with noncritical resources](#). This ends the procedure.
2. Select the problem entry by moving the cursor to the problem entry option field and entering option 8 to work with the problem.

Is Analyze Problem (option 1) available on the Work with Problem display?

No: Perform the following:

- a. Return to the initial problem log display (F12).
- b. Select the problem entry by moving the cursor to the problem entry option field and selecting the option to display details.
- c. Select the function key to display possible causes.

**Note:** If this function key is not available, use the customer reported symptom string for customer perceived information about this problem. Then, go to [Using the product activity log](#).

- d. Use the list of possible causes as the FRU list and go to step 5.
- Yes: Run Analyze Problem (option 1) from the Work with Problem display.

### Notes:

- a. For SRCs starting with 6112 or 9337, use the SRC and go to the [Reference codes](#) topic.



- b. If the message on the display directs you to use SST (System Service Tools), go to [COMIP01](#).

Was the problem corrected by the analysis procedure?

- ◆ No: Continue with the next step.
  - ◆ Yes: This ends the procedure.
3. Did problem analysis send you to another entry point in the service information?
- ◆ No: Continue with the next step.
  - ◆ Yes: Go to the entry point indicated by problem analysis. This ends the procedure.
4. Was the problem isolated to a list of failing items?
- ◆ Yes: Continue with the next step.
  - ◆ No: Go to [Problems with noncritical resources](#). This ends the procedure.
5. Exchange the failing items one at a time until the problem is repaired.

#### Notes:

- a. For failing items, see [Using failing item codes](#), and symbolic FRUs, see [Symbolic FRUs](#).  
 b. When exchanging FRUs, go to [Removing and replacing parts](#).

Has the problem been resolved?

- ◆ No: Contact your next level of support. This ends the procedure.
- ◆ Yes: This ends the procedure.

Parent topic: [Problem determination procedures](#)

---

## COMIP01

This procedure helps you to isolate problems with the communications input/output adapter (IOA) or input/output processor (IOP).

Please read and observe the danger notices in [Communication isolation procedure](#) before proceeding with this procedure.

1. If the system has logical partitions, perform this procedure from the logical partition that reported the problem. To determine if the system has logical partitions, go to [Determining if the system has logical partitions](#).
2. To determine which communications hardware to test, use the SRC from the problem summary form, or problem log, For details on line description information, see the Starting a Trace section of [Work with communications trace](#).
3. Perform the following:
  - a. Vary off the resources.
  - b. On the Start a Service Tool display, select Hardware service manager > Logical hardware resources > System bus resources > Resources associated with IOP for the attached IOPs in the list until you display the suspected failing hardware.
  - c. Select Verify on the hardware you want to test. The Verify option may be valid on the IOP, IOA, or port resource. When it is valid on the IOP resource, any replaceable memory will be tested. Communications IOAs are tested by using the Verify option on the port resource.
4. Run the IOA/IOP test(s). This may include any of the following:
  - ◆ Adapter internal test
  - ◆ Adapter wrap test (requires adapter wrap plug - available from your hardware service provider).
  - ◆ Processor internal test
  - ◆ Memory test
  - ◆ System port test

Does the IOA/IOP test(s) complete successfully?

- ◆ **No:** The problem is in the IOA or IOP. If a verify test identified a failing memory module, replace the memory module. On multiple card combinations, exchange the IOA card before exchanging the IOP card. Exchange the failing hardware. See [Removing and replacing parts](#). **This ends the procedure.**

- ◆ **Yes:** The IOA/IOP is good. Do NOT replace the IOA/IOP. Continue with the next step.

5. Before running tests on modems or network equipment, the remaining local hardware should be verified. Since the IOA/IOP test(s) have completed successfully, the remaining local hardware to be tested is the external cable.

Is the IOA adapter type 2838, with a UTP (unshielded twisted pair) external cable?

- ◆ **Yes:** Continue with the next step.

- ◆ **No:** Go to step 8.

6. Is the RJ-45 connector on the external cable correctly wired according to the EIA/TIA-568A standard? That is,

-Pins 1 and 2 using the same twisted pair,  
 -Pins 3 and 6 using the same twisted pair,  
 -Pins 4 and 5 using the same twisted pair,  
 -Pins 7 and 8 using the same twisted pair.

- ◆ **Yes:** Continue with the next step.

- ◆ **No:** Replace the external cable with correctly wired cable. **This ends the procedure.**

7. Do the Line Speed and Duplex values of the line description (DSPLINETH) match the corresponding values for the network device (router, hub or switch) port?

- ◆ **No:** Change the Line Speed and/or Duplex value for either the line description or the network device (router, hub or switch) port. **This ends the procedure.**

- ◆ **Yes:** Go to step 9.

8. Is the cable wrap test option available as a *Verify* test option for the hardware you are testing?

- ◆ **Yes:** Verify the external cable by running the cable wrap test. A wrap plug is required to perform the test. This plug is available from your hardware service provider. Wrap plug part numbers can be found in [Miscellaneous parts](#).

Does the cable wrap test complete successfully?

- ◇ **Yes:** Continue with the next step.

- ◇ **No:** The problem is in the cable. Exchange the cable. **This ends the procedure.**

- ◆ **No:** The communications IOA/IOP is not the failing item. One of the following could be causing the problem.

- ◇ External cable.

- ◇ The network.

- ◇ Any system or device on the network

- ◇ The configuration of any system or device on the network.

- ◇ Intermittent problems on the network.

- ◇ A new SRC - go to [Start of call procedure](#) or ask your next level of support for assistance.

Work with the customer or your next level of support to correct the problem. **This ends the procedure.**

9. All the local hardware is good. This completes the local hardware verification. The communications IOA/IOP and/or external cable is not the failing item.

One of the following could be causing the problem:

- ◆ The network

- ◆ Any system or device on the network

- ◆ The configuration of any system or device on the network

- ◆ Intermittent problems on the network

- ◆ A new SRC - go to [Start of call procedure](#) or ask your next level of support for assistance

Work with the customer or your next level of support to correct the problem. **This ends the procedure.**

**Parent topic:** [Communication isolation procedure](#)

---

## Miscellaneous parts

Use this information to find part numbers for miscellaneous items such as keyboards, cable wraps, or cleaning kits.

See the following for other parts:

- For parts that have CCINs, servers Failing Function Code numbers, or o/p Failing Function Code numbers, see [System parts](#).
- For mechanical and connecting parts, see [Part assembly diagrams](#).
- For internal signal and power cables and external cables, see [Cables](#).
- For Hardware Management Console (HMC) parts, see [Hardware Management Console \(HMC\) parts](#).

### Miscellaneous parts

| Description                                     | Units | Part number |
|-------------------------------------------------|-------|-------------|
| QIC cleaning cartridge                          |       | 59H4366     |
| Test tape QIC 4GB                               |       | 59H3661     |
| Test tape QIC 16GB                              |       | 87G1626     |
| Test tape QIC 25GB                              |       | 59H4127     |
| Test tape QIC 50GB                              |       | 35L0967     |
| Cleaning kit, optical cables                    |       | 46G6844     |
| CD-ROM test disk (FC 4425, FC 4525)             |       | 81F8902     |
| DVD test disk (FC 4430, FC 4530)                |       | 19P0484     |
| DVD cleaning kit                                |       | 19P0489     |
| Mouse (FC 1700)                                 |       | 76H5078     |
| II card wrap (TR LAN) FC 2744                   | AR    | 6165899     |
| LL card wrap                                    | AR    | 21H3548     |
| MM card wrap                                    | AR    | 21H3547     |
| NN card wrap                                    | AR    | 42H0540     |
| OO card wrap (WS PCI)                           | AR    | 45H2364     |
| QQ card wrap (WAN PCI)                          | AR    | 44H7479     |
| SS RJ-45 card wrap FC 2838 and FC 2892          | AR    | 21H4811     |
| UU card wrap (ISDN) FC 2750                     | AR    | 97H7749     |
| VV card wrap (ISDN) FC 2751                     | AR    | 97H7745     |
| WW card wrap FC 2761                            | AR    | 97H7754     |
| XX card wrap (FC 2744)                          | AR    | 44L0082     |
| YY card wrap (FC 2743)                          | AR    | 16G5609     |
| ZZ card wrap USB (FC 2890 and FC 2892)          | AR    | 04N5682     |
| Optical card wrap                               | AR    | 75G2725     |
| GL card wrap (Ethernet) - (FC 2760 and FC 5701) | AR    | 21P4745     |
| GM card wrap (FC 2742 and FC 2793)              | AR    | 53P1677     |
| ASYNC cable wrap                                | 1     | 17G2642     |

|                                                                                                          |    |         |
|----------------------------------------------------------------------------------------------------------|----|---------|
| V.24AD cable wrap                                                                                        | 1  | 21H3761 |
| RS232AD cable wrap                                                                                       | 1  | 21H3762 |
| V35AD cable wrap                                                                                         | 1  | 21H3763 |
| RS449AD cable wrap                                                                                       | 1  | 21H3790 |
| X21AD cable wrap                                                                                         | 1  | 21H3791 |
| Twinax port tester (93X2040)                                                                             | AR | 59X4262 |
| Adapter, 25 pin to 9 pin EIA232                                                                          | AR | 42R5145 |
| FC 5077 jumper                                                                                           | AR | 04N2653 |
| PCI card filler plate                                                                                    |    | 03K8992 |
| PCI U3 DASD tray                                                                                         |    | 53P2599 |
| GF card wrap - LC Optical (FC 2765, 2766, 2787, 5700, 5704, 5716)                                        | AR | 11P3847 |
| V35GM cable wrap                                                                                         | AR | 53P1678 |
| Power cord retainer clip (models 270, 800, 810, 820, 825, and FC 5075)                                   | AR | 5556740 |
| MCM repair kit - support rails (models ESCALA PL 3250R and ESCALA PL 6450R)                              | AR | 12R7403 |
| MCM repair kit - clamp assembly, blocks, shelves, and tools (models ESCALA PL 3250R and ESCALA PL 6450R) | AR | 12R7407 |
| MCM repair kit - shelf (models ESCALA PL 3250R and ESCALA PL 6450R)                                      | AR | 12R7409 |
| MCM repair kit - nest and blower blocking plate (models ESCALA PL 3250R and ESCALA PL 6450R)             | AR | 12R7411 |
| Memory repair kit (models ESCALA PL 3250R and ESCALA PL 6450R)                                           | AR | 16R1540 |
| MCM repair kit - tower (models ESCALA PL 3250R and ESCALA PL 6450R)                                      | AR | 16R1549 |
| RIO bracket (models ESCALA PL 3250R and ESCALA PL 6450R)                                                 | 1  | 12R7091 |

Parent topic: [Part number catalog](#)

## Removing and replacing parts

Use this information to remove and replace parts.

This is the starting point for all removal and replacement procedures. Perform the following steps.

**Attention:** When you are removing the cover while the system is powered on, errors may occur due to electromagnetic interference.

1. See [Finding part locations](#) to locate the part you are replacing.
2. Find the appropriate procedure in this topic for the field replaceable unit (FRU) you are removing, and follow the instructions.

**Attention:** If you are removing an IOA, IOP, IXS card, disk unit, removable media unit, or certain parts in an expansion unit, you might be able to keep the system powered on and perform a

concurrent exchange.

3. When you have completed the procedure, install the new unit by reversing the removal and replacement procedure unless otherwise noted.
4. After exchanging an item, see [Verifying the repair](#).
  - **Removing and replacing parts in the model ESCALA PL 245T/R**  
Use this information to remove and replace parts.
  - **Removing and replacing parts in the model ESCALA PL 250R-VL or ESCALA PL 450R-XS**
  - **Removing and replacing parts in the model ESCALA PL 250R-L, PL 250R-L+ or PL 450R-VL+**  
Use this information to remove and replace parts in the model ESCALA PL 250R-L, PL 250R-L+ or PL 450R-VL+ .
  - **Removing and replacing parts in the model ESCALA PL 250T/R, PL 250T/R+ or PL 450T/R-L+**  
Use this information to remove and replace parts in the model 112/85, ESCALA PL 250T/R+ or ESCALA PL 450T/R-L+, 9405-520, 9406-520, and ESCALA PL 250T/R.
  - **Removing and replacing parts in the model ESCALA PL 450T/R, PL 450T/R+ or PL 850T/R-L+**  
Use this information to remove and replace parts in the model ESCALA PL 450T/R+ or ESCALA PL 850T/R-L+, 9406-550, ESCALA PL 450T/R, .
  - **Removing and replacing parts in the model ESCALA PL 1650R-L+, 9406-570, and ESCALA PL 850R/PL 1650R/R+**  
Use this information to remove and replace parts in the model ESCALA PL 1650R-L+, 9406-570, and ESCALA PL 850R/PL 1650R/R+.
  - **Removing and replacing parts in the model 5/75**  
Use the Service Focal Point application on the Hardware Management Console (HMC) to find information on how to remove and replace parts in the model 185/75.
  - **Removing and replacing parts in the model ESCALA PL 3250R, PL 3250R+, ESCALA PL 6450 or PL 6450R+**  
Use the Service focal point application on the Hardware Management Console (HMC) to find information on how to remove and replace parts in the model ESCALA PL 3250R, ESCALA PL 6450R, and 9406-595.
  - **Removing and replacing parts in the 50/74, 50/79, 8079-002, and 8093-002 expansion units**  
Use this information to replace a part in the 50/74, 50/79, 8079-002, and 8093-002 expansion units.
  - **Removing and replacing parts in the 50/88 and 05/88 expansion units**  
Use this information to exchange parts in the 50/88 and 05/88 expansion units.
  - **Removing and replacing parts in the 50/94, 52/94, and 82/94 expansion units**  
Use this information to exchange parts in the 50/94, 52/94, and 82/94 expansion units.
  - **Removing and replacing parts in the 50/95, 05/95, and 11D/20 expansion units**  
Use this information to exchange parts in the 50/95, 05/95, and 11D/20 expansion units.
  - **Removing and replacing parts in the 57/86, 57/87, D24, and T24 expansion units**  
Use this information to exchange parts in the 57/86, 57/87, D24, and T24 expansion units.
  - **Removing and replacing parts in the 57/91, 57/94, and 406/1D expansion units**  
Use this information to exchange parts in the 57/91, 57/94, and 406/1D expansion units.
  - **Removing and replacing parts in the 57/95 expansion unit**  
Use this information to exchange parts in the 57/95 expansion unit.
  - **Removing and replacing parts in the 11D/11 and 57/90 expansion units**  
Use this information to exchange parts in the 11D/11 and 57/90 expansion units.
  - **Exchanging RIO cables**  
Use this procedure to replace the RIO cables concurrently. You will need to perform the following steps for both ends of the cable that you are replacing.
  - **HMC parts removal and replacement procedures**
  - **Removing and replacing parts on type 2748, 2757, 2763, 2778, 2780, 2782, 4758, 4764, 5703, 5708, 5709, 571B, 571E, 571F, 573D, 574F, 575B**  
Use this information to exchange parts on type 2748, 2757, 2763, 2778, 2780, 2782, 4758, 4764, 5703, 5708, 5709, 571B, 571E, 571F, 573D, 574F, 575B cards, only when directed from another procedure.
  - **Tape cartridge, manual removal**  
Use this information to remove a tape cartridge from a tape unit.
  - **Optical media (CD-ROM, DVD-ROM, and DVD-RAM) - manual removal**  
Use this procedure to manually remove optical media (CD-ROM, DVD-ROM, or DVD-RAM) from the disc tray.

**Parent topic:** [Locating and exchanging parts](#)

---

## Removing and replacing parts in the model ESCALA PL 245T/R

Use this information to remove and replace parts.

### **DANGER**When working on or around the system, observe the following precautions:

Electrical voltage and current from power, telephone, and communication cables are hazardous. To avoid a shock hazard:

- Connect power to this unit only with the provided power cord. Do not use the provided power cord for any other product.
- Do not open or service any power supply assembly.
- Do not connect or disconnect any cables or perform installation, maintenance, or reconfiguration of this product during an electrical storm.
- The product might be equipped with multiple power cords. To remove all hazardous voltages, disconnect all power cords.
- Connect all power cords to a properly wired and grounded electrical outlet. Ensure that the outlet supplies proper voltage and phase rotation according to the system rating plate.
- Connect any equipment that will be attached to this product to properly wired outlets.
- When possible, use one hand only to connect or disconnect signal cables.
- Never turn on any equipment when there is evidence of fire, water, or structural damage.
- Disconnect the attached power cords, telecommunications systems, networks, and modems before you open the device covers, unless instructed otherwise in the installation and configuration procedures.
- Connect and disconnect cables as described in the following procedures when installing, moving, or opening covers on this product or attached devices.  
To Disconnect:
  1. Turn off everything (unless instructed otherwise).
  2. Remove the power cords from the outlets.
  3. Remove the signal cables from the connectors.
  4. Remove all cables from the devices

To Connect:

1. Turn off everything (unless instructed otherwise).
2. Attach all cables to the devices.
3. Attach the signal cables to the connectors.
4. Attach the power cords to the outlets.
5. Turn on the devices.

(D005)

**Note:** For most parts, the removal and replacement procedures are customer tasks and can be found in the [Installing hardware](#) topic.

- [Control panel](#)
- [Covers](#)
- [Disk drive](#)
- [Fan](#)
- [Light path diagnostic card](#)
- [Media device](#)
- [Memory modules](#)
- [PCI adapter](#)
- [Power supply](#)
- [Exchanging the system backplane in the model ESCALA PL 245T/R](#)
- [Time of day battery](#)

- **Voltage regulator module**

Parent topic: [Removing and replacing parts](#)

---

## Removing and replacing parts in the model ESCALA PL 250R-VL or ESCALA PL 450R-XS

### **DANGER**When working on or around the system, observe the following precautions:

Electrical voltage and current from power, telephone, and communication cables are hazardous. To avoid a shock hazard:

- Connect power to this unit only with the provided power cord. Do not use the provided power cord for any other product.
- Do not open or service any power supply assembly.
- Do not connect or disconnect any cables or perform installation, maintenance, or reconfiguration of this product during an electrical storm.
- The product might be equipped with multiple power cords. To remove all hazardous voltages, disconnect all power cords.
- Connect all power cords to a properly wired and grounded electrical outlet. Ensure that the outlet supplies proper voltage and phase rotation according to the system rating plate.
- Connect any equipment that will be attached to this product to properly wired outlets.
- When possible, use one hand only to connect or disconnect signal cables.
- Never turn on any equipment when there is evidence of fire, water, or structural damage.
- Disconnect the attached power cords, telecommunications systems, networks, and modems before you open the device covers, unless instructed otherwise in the installation and configuration procedures.
- Connect and disconnect cables as described in the following procedures when installing, moving, or opening covers on this product or attached devices.
  - To Disconnect:
    1. Turn off everything (unless instructed otherwise).
    2. Remove the power cords from the outlets.
    3. Remove the signal cables from the connectors.
    4. Remove all cables from the devices

To Connect:

1. Turn off everything (unless instructed otherwise).
2. Attach all cables to the devices.
3. Attach the signal cables to the connectors.
4. Attach the power cords to the outlets.
5. Turn on the devices.

(D005)

Choose the part you want to replace.

**Note:** For most parts in the model ESCALA PL 250R-VL or ESCALA PL 450R-XS, the removal and replacement procedures are customer tasks and can be found in the [Installing hardware](#) topic. Use the following links to go directly to these procedures.

- [Control panel](#)
- [Fan](#)
- [Install into a rack](#)
- [Media device](#)
- [Memory modules](#)
- [PCI adapter](#)
- [Power supply](#)
- [System backplane](#)
- [Time of day battery](#)
- [Voltage regulator module](#)
- [VPD card](#)

Parent topic: [Removing and replacing parts](#)

---

## Exchanging the VPD card in the model ESCALA PL 250R-VL or ESCALA PL 450R-XS

**Attention:** The VPD card contains data that is vital to system operation:

- Machine type, model, and serial number
- System brand
- System unique ID (SUID)
- Activation codes for Power On Demand and Virtualization Engine Technologies (if applicable)

If the VPD card is replaced, this data must be programmed into the replacement VPD card. If the system is still functional prior to the replacement of the VPD card, view and record the System unique ID (SUID).

New, replacement activation codes for Power On Demand and Virtualization Engine Technologies must be generated. The original activation codes for the system cannot be reused. Contact your next level of support for new activation codes.

To exchange the VPD card in the model ESCALA PL 250R-VL or ESCALA PL 450R-XS, perform the following procedure:

1. If you are removing the VPD card as part of another procedure, continue to the next step. If you are removing the VPD card because it is not operational, verify that it is the failing part. See [Identify a failing part](#).
2. If the system is still functional and you are replacing the VPD card with a new VPD card, view and record the System unique ID (SUID). This can be done by using a Hardware Management Console (HMC) or PC to access the ASMI. Refer to [Accessing the Advanced System Management Interface](#) for information about setting up the ASMI, and [Managing your server using the Advanced System Management Interface](#) for information about using the ASMI. For further information, see [Viewing vital product data](#).
3. Perform the following to prepare the system:
  - a. Ensure that the customer has taken appropriate actions to remove the server from normal use.
  - b. Power off the system. For instructions, see [Stopping the system](#).
  - c. Disconnect the power source from the system.

**Note:** This system might be equipped with a second power supply. Before continuing with this procedure, ensure that the power source to the system has been completely disconnected.

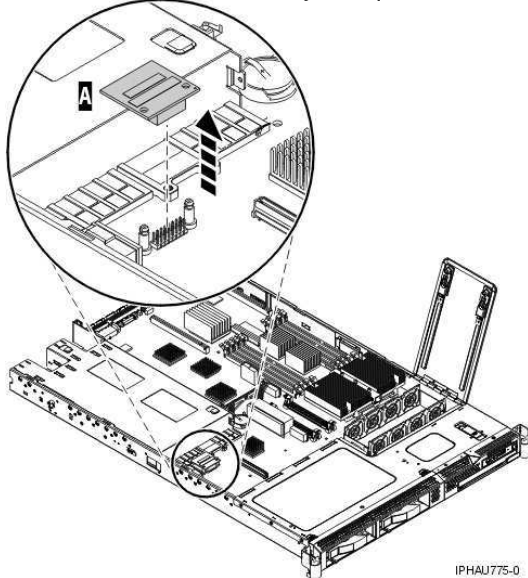
- d. Attach a wrist strap to a metal surface of your hardware to prevent electrostatic discharge from damaging your hardware. If you do not have a wrist strap, touch a metal surface of the



system before installing or replacing hardware.

**Note:** Follow the same precautions that you would use if you were not using the wrist strap. A wrist strap is for static control. It will not increase or decrease your risk of receiving electric shock when using or working on electrical equipment.

4. Remove the service access cover. For instructions, see [Remove the service access cover](#).
5. Pull the VPD card out as you squeeze the retainers together (A).



IPHAU775-0

6. To insert a VPD card, reverse the steps in this procedure.
7. If you replaced the VPD card as part of another procedure, return to that procedure now.
8. Connect the line cords to each power supply.
9. Use the ASMI to set the system identifiers. Access the ASMI by either using a Hardware Management Console (HMC) or PC to access the ASMI. Refer to [Accessing the Advanced System Management Interface](#) for information about setting up the ASMI, and [Managing your server using the Advanced System Management Interface](#) for information about using the ASMI. Update the system configuration settings. For further information, see [Programming vital product data](#).
10. If the customer had Power On Demand activation codes, obtain new activation codes from your next level of support and enter the new codes. For more information, see [Working with Power On Demand](#).
11. If the customer had Virtualization Engine Technologies activation codes, obtain new activation codes from your next level of support and enter the new codes. For more information, see [Entering the activation code for Virtualization Engine technologies](#).
12. Power on the system. To review the power on procedure, go to [Powering on and powering off](#).
13. If you replaced the VPD card because it was not operational, verify that the new resource is functional. See [Verifying the repair](#). This ends the procedure.

**Parent topic:** [Removing and replacing parts in the model ESCALA PL 250R-VL or ESCALA PL 450R-XS](#)

## Removing and replacing parts in the model ESCALA PL 250R-L, PL 250R-L+ or PL 450R-VL+

Use this information to remove and replace parts in the model ESCALA PL 250R-L, PL 250R-L+ or PL 450R-VL+ .

### **DANGER**When working on or around the system, observe the following precautions:

Electrical voltage and current from power, telephone, and communication cables are hazardous. To avoid a shock hazard:

- Connect power to this unit only with the provided power cord. Do not use the provided power cord for any other product.
- Do not open or service any power supply assembly.
- Do not connect or disconnect any cables or perform installation, maintenance, or reconfiguration of this product during an electrical storm.
- The product might be equipped with multiple power cords. To remove all hazardous voltages, disconnect all power cords.
- Connect all power cords to a properly wired and grounded electrical outlet. Ensure that the outlet supplies proper voltage and phase rotation according to the system rating plate.
- Connect any equipment that will be attached to this product to properly wired outlets.
- When possible, use one hand only to connect or disconnect signal cables.
- Never turn on any equipment when there is evidence of fire, water, or structural damage.
- Disconnect the attached power cords, telecommunications systems, networks, and modems before you open the device covers, unless instructed otherwise in the installation and configuration procedures.
- Connect and disconnect cables as described in the following procedures when installing, moving, or opening covers on this product or attached devices.

To Disconnect:

1. Turn off everything (unless instructed otherwise).
2. Remove the power cords from the outlets.
3. Remove the signal cables from the connectors.
4. Remove all cables from the devices

To Connect:

1. Turn off everything (unless instructed otherwise).
2. Attach all cables to the devices.
3. Attach the signal cables to the connectors.
4. Attach the power cords to the outlets.
5. Turn on the devices.

(D005)

**Note:** For most parts in the model ESCALA PL 250R-L, ESCALA PL 250R-L+ or ESCALA PL 450R-VL+, , the removal and replacement procedures are customer tasks and can be found in the [Installing hardware](#) topic.

- [Control panel](#)
- [Disk drive](#)
- [Fan](#)
- [Media device](#)
- [Memory module](#)
- [PCI adapter](#)
- [Power supply](#)
- [Storage I/O adapter cache battery pack](#)
- [System backplane](#)
- [Time-of-day battery](#)
- [Voltage regulator module](#)
- [VPD card](#)

**Parent topic:** [Removing and replacing parts](#)

---

## Removing and replacing parts in the model ESCALA PL 250T/R, PL 250T/R+ or PL 450T/R-L+

Use this information to remove and replace parts in the model 112/85, ESCALA PL 250T/R+ or ESCALA PL 450T/R-L+, 9405-520, 9406-520, and ESCALA PL 250T/R.

**DANGER** When working on or around the system, observe the following precautions:

Electrical voltage and current from power, telephone, and communication cables are hazardous. To avoid a shock hazard:

- Connect power to this unit only with the provided power cord. Do not use the provided power cord for any other product.
- Do not open or service any power supply assembly.
- Do not connect or disconnect any cables or perform installation, maintenance, or reconfiguration of this product during an electrical storm.
- The product might be equipped with multiple power cords. To remove all hazardous voltages, disconnect all power cords.
- Connect all power cords to a properly wired and grounded electrical outlet. Ensure that the outlet supplies proper voltage and phase rotation according to the system rating plate.
- Connect any equipment that will be attached to this product to properly wired outlets.
- When possible, use one hand only to connect or disconnect signal cables.
- Never turn on any equipment when there is evidence of fire, water, or structural damage.
- Disconnect the attached power cords, telecommunications systems, networks, and modems before you open the device covers, unless instructed otherwise in the installation and configuration procedures.
- Connect and disconnect cables as described in the following procedures when installing, moving, or opening covers on this product or attached devices.
  - To Disconnect:
    1. Turn off everything (unless instructed otherwise).
    2. Remove the power cords from the outlets.
    3. Remove the signal cables from the connectors.
    4. Remove all cables from the devices

To Connect:

1. Turn off everything (unless instructed otherwise).
2. Attach all cables to the devices.
3. Attach the signal cables to the connectors.
4. Attach the power cords to the outlets.
5. Turn on the devices.

(D005)

**Note:** For most parts in the model 112/85, ESCALA PL 250T/R+ or ESCALA PL 450T/R-L+, 9405-520, 9406-520, and ESCALA PL 250T/R, the removal and replacement procedures are customer tasks and can be found in the [Installing hardware](#) topic.

- [Control panel and signal cable](#)
- [Disk drive](#)
- [Disk drive backplane](#)
- [Fan](#)
- [Fan tray](#)
- [Media device](#)
- [Media device enclosure](#)
- [Memory module](#)
- [PCI adapter](#)
- [PCI adapter divider](#)
- [Power supply](#)
- [Rack-mounted system unit latch bracket](#)
- [RAID enablement card](#)
- [Service processor assembly](#)
- [Storage I/O adapter cache battery pack](#)
- [System backplane](#)

- [Time-of-day battery](#)
- [Voltage regulator module](#)
- [VPD card](#)

Parent topic: [Removing and replacing parts](#)

---

## Removing and replacing parts in the model ESCALA PL 450T/R, PL 450T/R+ or PL 850T/R-L+

Use this information to remove and replace parts in the model ESCALA PL 450T/R+ or ESCALA PL 850T/R-L+, 9406-550, ESCALA PL 450T/R, .

### **DANGER**When working on or around the system, observe the following precautions:

Electrical voltage and current from power, telephone, and communication cables are hazardous. To avoid a shock hazard:

- Connect power to this unit only with the provided power cord. Do not use the provided power cord for any other product.
- Do not open or service any power supply assembly.
- Do not connect or disconnect any cables or perform installation, maintenance, or reconfiguration of this product during an electrical storm.
- The product might be equipped with multiple power cords. To remove all hazardous voltages, disconnect all power cords.
- Connect all power cords to a properly wired and grounded electrical outlet. Ensure that the outlet supplies proper voltage and phase rotation according to the system rating plate.
- Connect any equipment that will be attached to this product to properly wired outlets.
- When possible, use one hand only to connect or disconnect signal cables.
- Never turn on any equipment when there is evidence of fire, water, or structural damage.
- Disconnect the attached power cords, telecommunications systems, networks, and modems before you open the device covers, unless instructed otherwise in the installation and configuration procedures.
- Connect and disconnect cables as described in the following procedures when installing, moving, or opening covers on this product or attached devices.

To Disconnect:

1. Turn off everything (unless instructed otherwise).
2. Remove the power cords from the outlets.
3. Remove the signal cables from the connectors.
4. Remove all cables from the devices

To Connect:

1. Turn off everything (unless instructed otherwise).
2. Attach all cables to the devices.
3. Attach the signal cables to the connectors.
4. Attach the power cords to the outlets.
5. Turn on the devices.

(D005)

**Note:** For most parts in the model ESCALA PL 450T/R+ or ESCALA PL 850T/R-L+, 9406-550, ESCALA PL 450T/R, , the removal and replacement procedures are customer tasks and can be found in the [Installing hardware](#) topic.

- **Control panel and signal cable**
- **Disk drive**
- **Disk drive backplane**
- **Fan**
- **Media device**
- **Media device enclosure**
- **Memory module**
- **PCI adapter**
- **PCI adapter dividers and light pipes**
- **Power supply**
- **Rack-mounted system unit latch bracket**
- **RAID enablement card**
- **RIO/HSL cables**
- **RIO/HSL adapter card**
- **System backplane**

Use this procedure to remove and replace a system backplane in a model ESCALA PL 450T/R+ or ESCALA PL 850T/R-L+, 9406-550, ESCALA PL 450T/R, .

- **System processor assembly**
- **Time-of-day battery**
- **Voltage regulator module**
- **VPD card**

**Parent topic:** [Removing and replacing parts](#)

---

## Removing and replacing parts in the model ESCALA PL 1650R-L+, 9406-570, and ESCALA PL 850R/PL 1650R/R+

Use this information to remove and replace parts in the model ESCALA PL 1650R-L+, 9406-570, and ESCALA PL 850R/PL 1650R/R+.

### **DANGER**When working on or around the system, observe the following precautions:

Electrical voltage and current from power, telephone, and communication cables are hazardous. To avoid a shock hazard:

- Connect power to this unit only with the provided power cord. Do not use the provided power cord for any other product.
- Do not open or service any power supply assembly.
- Do not connect or disconnect any cables or perform installation, maintenance, or reconfiguration of this product during an electrical storm.
- The product might be equipped with multiple power cords. To remove all hazardous voltages, disconnect all power cords.
- Connect all power cords to a properly wired and grounded electrical outlet. Ensure that the outlet supplies proper voltage and phase rotation according to the system rating plate.
- Connect any equipment that will be attached to this product to properly wired outlets.
- When possible, use one hand only to connect or disconnect signal cables.
- Never turn on any equipment when there is evidence of fire, water, or structural damage.
- Disconnect the attached power cords, telecommunications systems, networks, and modems before you open the device covers, unless instructed otherwise in the installation and configuration procedures.
- Connect and disconnect cables as described in the following procedures when installing, moving, or opening covers on this product or attached devices.
  - To Disconnect:
    1. Turn off everything (unless instructed otherwise).
    2. Remove the power cords from the outlets.
    3. Remove the signal cables from the connectors.
    4. Remove all cables from the devices

To Connect:

1. Turn off everything (unless instructed otherwise).
2. Attach all cables to the devices.
3. Attach the signal cables to the connectors.
4. Attach the power cords to the outlets.
5. Turn on the devices.

(D005)

**Note:** For most parts in the model ESCALA PL 1650R-L+, 9406-570, and ESCALA PL 850R/PL 1650R/R+, the removal and replacement procedures are customer tasks and can be found in the [Installing hardware](#) topic.

- [Control panel](#)
- [Disk drive](#)
- [Disk drive enclosure and backplane](#)
- [Fan](#)
- [Exchanging the I/O backplane in the model ESCALA PL 1650R-L+ and ESCALA PL 850R/PL 1650R/R+](#)
- [Media device](#)
- [Media enclosure and backplane](#)
- [Memory module](#)
- [PCI adapter](#)
- [Power supply](#)
- [Exchanging the RAID enablement card in the model ESCALA PL 1650R-L+ and ESCALA PL 850R/PL 1650R/R+](#)
- [RIO/HSL card](#)
- [SCSI-IDE converter card](#)
- [Flexible service processor and time-of-day battery](#)
- [Flexible service processor](#)
- [SMP processor cable](#)
- [System backplane](#)
- [System processor card](#)
- [Voltage regulator module](#)
- [Exchanging the VPD card in the model ESCALA PL 1650R-L+ and ESCALA PL 850R/PL 1650R/R+](#)

**Parent topic:** [Removing and replacing parts](#)

---

## Removing and replacing parts in the model 5/75

Use the Service Focal Point application on the Hardware Management Console (HMC) to find information on how to remove and replace parts in the model 185/75.

Do the following to access the Service Focal Point application:

1. Log into the HMC as the service representative.
2. In the Navigation area, select the Service Applications icon.
3. Select the Service Focal Point icon.
4. Select Exchange Parts. The Exchange Parts window opens. Follow the instructions on the Exchange Parts window until you reach the removal and replacement procedures for the selected part.

Parent topic: [Removing and replacing parts](#)

---

## Removing and replacing parts in the model ESCALA PL 3250R, PL 3250R+, ESCALA PL 6450 or PL 6450R+

Use the Service focal point application on the Hardware Management Console (HMC) to find information on how to remove and replace parts in the model ESCALA PL 3250R, ESCALA PL 6450R, and 9406-595.

Do the following to access the Service focal point application:

1. Log into the HMC as the service representative.
2. In the Navigation area, select the Service Applications icon.
3. Select the Service Focal Point icon.
4. Select Exchange Parts. The Exchange Parts window opens. Follow the instructions on the Exchange Parts window until you reach the removal and replacement procedures for the selected part.

Parent topic: [Removing and replacing parts](#)

---

## Removing and replacing parts in the 50/74, 50/79, 8079-002, and 8093-002 expansion units

Use this information to replace a part in the 50/74, 50/79, 8079-002, and 8093-002 expansion units.

- [AC charger A01 \(single line cord\)](#)
- [AC modules A01 and A02 \(dual line cord\)](#)
- [Air moving devices B01 and B02](#)
- [Batteries T01, T02, T03, and T04](#)
- [PCI adapter](#)
- [Cards \(concurrent\)](#)

Use this procedure to remove or replace cards concurrently in the 50/74, 50/79, 50/94, 52/94, 8079-002, 8093-002, 8094-002, and 82/94 expansion units.

- [Cards \(dedicated\)](#)  
Use this procedure to remove or replace cards using dedicated maintenance in the 50/74, 50/79, 50/94, 52/94, 8079-002, 8093-002, 8094-002, and 82/94 expansion units.
- [Covers](#)
- [Device boards DB1, DB2, DB3](#)  
Use this procedure to remove or replace the device board in the 50/74, 50/79, 8079-002, and 8093-002 expansion units.
- [Disk drive](#)
- [Control panel NB1](#)
- [Media device](#)
- [Power distribution board PB1](#)
- [Power supplies P00, P01, P02, and P03](#)
- [Tower card CB1](#)

Parent topic: [Removing and replacing parts](#)

---

## Exchanging cards (concurrent) in the 50/74, 50/79, 50/94, 52/94, 8079-002, 8093-002, 8094-002, and 82/94 expansion units

Use this procedure to remove or replace cards concurrently in the 50/74, 50/79, 50/94, 52/94, 8079-002, 8093-002, 8094-002, and 82/94 expansion units.

## Concurrent/dedicated guidelines

In some cases you do not need to power down the system to change PCI cards. Use the following guidelines to determine if you should use dedicated or concurrent removal and replacement procedures. If you use concurrent maintenance on a partitioned system, follow the procedures from the partition that owns the resource. If the resource is not owned, follow the procedure from the primary partition.

### For 50/74, 50/79, 50/94, and 52/94 IXS cards:

The IXS cards require dedicated maintenance. Do not power down the individual card slot. You can power down the 50/74 unit, or the top or bottom half of a 50/79 or 52/94 unit. See [Exchanging cards \(dedicated\) in the 50/74, 50/79, 50/94, 52/94, 8079-002, 8093-002, 8094-002, and 82/94 expansion units](#).

### For 50/74, 50/79, 50/94, and 52/94 cards - except IXS cards:

- Card positions that permit card level concurrent maintenance using HSM:
  - ◆ For 50/74 or 50/79: Card positions C01 through C07 and C09 through C15 permit card level concurrent maintenance using HSM. You can power down the individual card slot.
  - ◆ For 50/94 or 52/94: Card positions C01 through C09, and C11 through C15 permit card level concurrent maintenance using HSM. You can power down the individual card slot.
- If the resource is the load source IOA or the load source IOP, or any other storage IOA/IOP with critical DASD attached for the system, primary, or secondary partition, follow the on-screen instructions when you use HSM to power down the IOP or IOA. Instructions to use functions 68 and 69 on the control panel will be included.
- If the resource is the console IOA or the console IOP for the system or primary partition, you cannot power down the domain.
- If the resource is the console IOA or the console IOP for a secondary partition, then power down the secondary partition and follow the procedure from the primary partition.

**CAUTION:**The system contains circuit cards, assemblies, or both that contain lead solder. To avoid the release of lead (Pb) into the environment, do not burn. Discard the circuit card as instructed by local regulations. (C014)

**Attention:** All cards are sensitive to electrostatic discharge. See [Working with electrostatic discharge-sensitive parts](#).

**Parent topic:** [Removing and replacing parts in the 50/74, 50/79, 8079-002, and 8093-002 expansion units](#)

**Parent topic:** [Removing and replacing parts in the 50/94, 52/94, and 82/94 expansion units](#)

## Remove cards concurrently

To remove cards concurrently:

1. On the command line, enter the Start System Service Tools command:

```
STRSST
```

If you cannot get to SST, select DST. See [Dedicated Service Tools \(DST\)](#) for details.

**Attention:** Do not perform a system IPL to get to DST.



2. Select Start a Service Tool > Hardware Service Manager > Packaging hardware resources.
3. Select Hardware contained within package for the Frame ID that contains the IOA or IOP that you are removing.
4. Find the card position for the IOA or IOP that you are removing and select Concurrent maintenance.
5. A listing of the power domain is shown. Select the Power off domain function key. Everything within the IOA's or IOP's power domain will be powered off .
6. To see the status of the power domain, select the Display power states function key.
7. Find the IOA or IOP that you are removing and select Toggle LED blink off/on.
8. Remove the cover to access the card that you are removing from the system. See [Exchanging the covers in the 50/74, 50/79, 50/94, 52/94, 8079-002, 8093-002, 8094-002, and 82/94 expansion units](#).
9. Remove the EMC access plate that is located directly above the card enclosure. Press the two latching mechanisms together and tilt the top of the cover away from the frame to remove it.
10. Look at the power LED for the card that you are removing to ensure that it is powered off. The power LED is located to the left of and directly above the card slot. If the LED is blinking multiple times per second (rapidly) or it is off, then the card is powered off.

**Note:** For a double wide adapter, there is only one power LED visible for both slots.

11. Disconnect and label any cables from the card that you wish to remove.
12. Turn the latch counter clockwise and lift upward on the black latch to release the card.
13. Gently pull the card off the backplane. This ends the procedure.

### Replace cards concurrently

To replace cards concurrently:

1. Install the card in to the system by reversing the card removal procedure above.
2. Select the Power on domain function key for the IOA or IOP that you are installing.

**Note:** To the right of the description field you will see one or both of the following symbols displayed:

- ◆ \* indicates the location to which the system will assign the resource.
- ◆ > indicates the location to which the resource was last assigned.

3. Press Enter. The Work with Controlling Resource display will appear.
4. Determine the location where you want to assign the resource and select Assign to for that location.
5. Wait for the Hardware Resource Concurrent Maintenance display to appear with the message indicating that the power on is complete.
6. After exchanging an item, go to [Verifying the repair](#).
7. If you have exchanged a 2766, 2787, or 280E Fibre Channel IOA, the external storage subsystem must be updated to use the world-wide port name of the new IOA. Refer to [Updating the world-wide port name for a new 2766 or 2787 IOA](#) for details. This ends the procedure.

---

## Exchanging cards (dedicated) in the 50/74, 50/79, 50/94, 52/94, 8079-002, 8093-002, 8094-002, and 82/94 expansion units

Use this procedure to remove or replace cards using dedicated maintenance in the 50/74, 50/79, 50/94, 52/94, 8079-002, 8093-002, 8094-002, and 82/94 expansion units.

In some cases, you do not need to power down the system to change PCI cards. Use the guidelines in [Exchanging cards \(concurrent\) in the 50/74, 50/79, 50/94, 52/94, 8079-002, 8093-002, 8094-002, and 82/94 expansion units](#) to determine if you should use dedicated or concurrent exchange procedures.

**CAUTION:**The system contains circuit cards, assemblies, or both that contain lead solder. To avoid the release of lead (Pb) into the environment, do not burn. Discard the circuit card as instructed by local regulations. (C014)

**Attention:** All cards are sensitive to electrostatic discharge. See [Working with electrostatic discharge-sensitive parts](#).

To remove or replace the cards (dedicated):

1. Power off the expansion unit. See [Powering off an expansion unit](#).
2. Remove the ac power cord from the frame that you are working on.
3. Remove the cover to access the card that you are removing from the system. See [Exchanging the covers in the 50/74, 50/79, 50/94, 52/94, 8079-002, 8093-002, 8094-002, and 82/94 expansion units](#).
4. Remove the EMC access plate that is located directly above the card enclosure. Press the two latching mechanisms together and tilt the top of the cover away from the frame to remove it.
5. Disconnect and label any cables from the card that you wish to remove.
6. Turn the latch counter clockwise and lift upward on the black latch to release the card.
7. Gently pull the card off the backplane.
8. Reverse this procedure to replace the card. After exchanging a failing item, go to [Verifying the repair](#).
9. If you have exchanged a 2766, 2787, or 280E Fibre Channel IOA, the external storage subsystem must be updated to use the world-wide port name of the new IOA. Refer to [Updating the world-wide port name for a new 2766, 2787, or 280E IOA](#) for details. This ends the procedure..

**Parent topic:** [Removing and replacing parts in the 50/74, 50/79, 8079-002, and 8093-002 expansion units](#)  
**Parent topic:** [Removing and replacing parts in the 50/94, 52/94, and 82/94 expansion units](#)

---

## Exchanging the covers in the 50/74, 50/79, 50/94, 52/94, 8079-002, 8093-002, 8094-002, and 82/94 expansion units

Use this procedure to remove or replace covers in the 50/74, 50/79, 50/94, 52/94, 8079-002, 8093-002, 8094-002, and 82/94 expansion units.

- To open or remove the front cover, refer to [Figure 1](#).
- To open or remove the rear cover, refer to [Figure 2](#).

Perform the following steps to open or remove each cover.

1. Unlock the cover (front only).
2. Open the cover by grasping its right side and pulling it towards you.
3. After opening the cover, press down on lever (B), which is located inside along the top, left side of the cover.
4. Tilt the top of the cover away from the expansion unit, and lift the cover off. This ends the procedure.

Figure 1. Front cover - removal

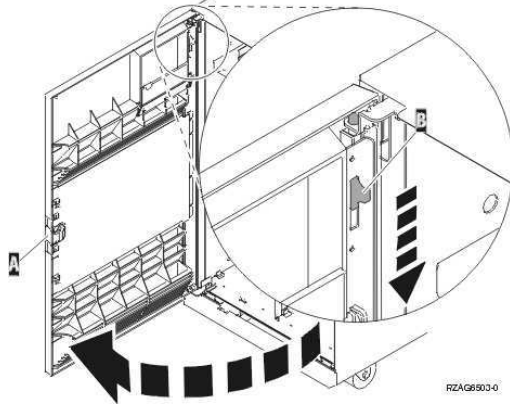
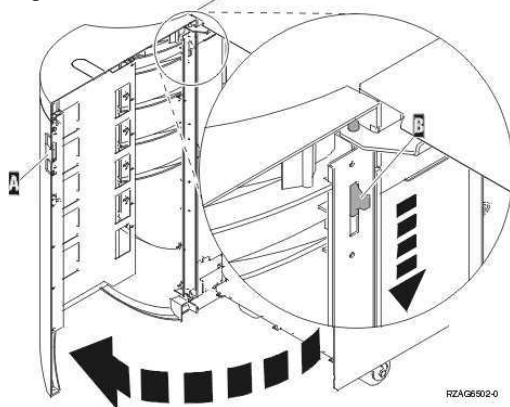


Figure 2. Rear cover - removal



Parent topic: [Removing and replacing parts in the 50/74, 50/79, 8079-002, and 8093-002 expansion units](#)  
 Parent topic: [Removing and replacing parts in the 50/94, 52/94, and 82/94 expansion units](#)

## Removing and replacing parts in the 50/88 and 05/88 expansion units

Use this information to exchange parts in the 50/88 and 05/88 expansion units.

### **DANGER**When working on or around the system, observe the following precautions:

Electrical voltage and current from power, telephone, and communication cables are hazardous. To avoid a shock hazard:

- Connect power to this unit only with the provided power cord. Do not use the provided power cord for any other product.
- Do not open or service any power supply assembly.
- Do not connect or disconnect any cables or perform installation, maintenance, or reconfiguration of this product during an electrical storm.
- The product might be equipped with multiple power cords. To remove all hazardous voltages, disconnect all power cords.
- Connect all power cords to a properly wired and grounded electrical outlet. Ensure that the outlet supplies proper voltage and phase rotation according to the system rating plate.
- Connect any equipment that will be attached to this product to properly wired outlets.
- When possible, use one hand only to connect or disconnect signal cables.
- Never turn on any equipment when there is evidence of fire, water, or structural damage.
- Disconnect the attached power cords, telecommunications systems, networks, and modems before you open the device covers, unless instructed otherwise in the installation and configuration procedures.

- Connect and disconnect cables as described in the following procedures when installing, moving, or opening covers on this product or attached devices.

To Disconnect:

1. Turn off everything (unless instructed otherwise).
2. Remove the power cords from the outlets.
3. Remove the signal cables from the connectors.
4. Remove all cables from the devices

To Connect:

1. Turn off everything (unless instructed otherwise).
2. Attach all cables to the devices.
3. Attach the signal cables to the connectors.
4. Attach the power cords to the outlets.
5. Turn on the devices.

(D005)

- [Air moving devices B01 and B02](#)

- [AMD controller card BB1](#)

- [PCI adapter](#)

- [Cards \(concurrent\)](#)

Use this procedure to remove or replace cards concurrently in the 50/88 and 05/88 expansion units.

- [Cards \(dedicated\)](#)

- [Covers](#)

Use this procedure to remove or replace the covers in the 50/88 and 05/88 expansion units.

- [Control panel NB1](#)

- [Power distribution backplane PB1](#)

- [Power supplies P01 and P02](#)

- [Tower card CB1](#)

Parent topic: [Removing and replacing parts](#)

---

## Exchanging cards (dedicated) in the 50/88 and 05/88 expansion units

Use this procedure to remove or replace cards (dedicated) in the 50/88 and 05/88 expansion units.

In some cases, you do not need to power down the system to change PCI cards. Use the guidelines in [Exchanging cards \(concurrent\) in the 50/88 and 05/88 expansion units](#) to determine if you should use dedicated or concurrent remove and replace procedures.

**CAUTION:**The system contains circuit cards, assemblies, or both that contain lead solder. To avoid the release of lead (Pb) into the environment, do not burn. Discard the circuit card as instructed by local regulations. (C014)

**Attention:** All cards are sensitive to electrostatic discharge (see [Working with electrostatic discharge-sensitive parts](#)).

1. Power off the PCI expansion unit (see [Powering off an expansion unit](#)).
2. Disconnect the two ac power cords from the AC box.
3. Remove the rear cover (see [Exchanging the covers in the 50/88 and 05/88 expansion units](#)).
4. Remove the EMC access plate over the card enclosure by loosening the thumb screws and pulling it towards you.

5. Remove the retaining screws from the card enclosure.
6. Disconnect and label the cables that are attached to the back of the card enclosure.
7. Slide the card enclosure partially out of the frame.
8. Disconnect and label any cables from the card that you wish to remove.
9. Turn the latch counter-clockwise and lift up on the black latch to release the card.
10. Remove the card by gently pulling it out.
11. Install the new card by reversing this procedure. After exchanging the failing item, go to [Verifying the repair](#).
12. If you have exchanged a 2766, 2787, or 280E Fibre Channel IOA, the external storage subsystem must be updated to use the world-wide port name of the new IOA. Refer to [Updating the world-wide port name for a new 2766, 2787, or 280E IOA](#) for details. This ends the procedure.

**Parent topic:** [Removing and replacing parts in the 50/88 and 05/88 expansion units](#)

---

## Exchanging the covers in the 50/88 and 05/88 expansion units

Use this procedure to remove or replace the covers in the 50/88 and 05/88 expansion units.

**Attention:** If you remove the cover while the expansion unit is powered on, errors may occur due to electromagnetic interference.

- To remove the front cover, grasp the edges of the front cover and pull it towards you.
- To open or remove the rear cover when the expansion unit is mounted either on top of a 50/74 or in a 0551 rack, perform the following steps:
  1. Grasp the right side of the cover and pull it towards you to open it.
  2. After opening the cover, press down on the lever that is located inside along the top, left-side of the cover.
  3. Tilt the top of the cover away from the unit and lift the cover off.

**Note:** Refer to [Figure 2. Rear cover - removal](#) in [Exchanging the covers in the 50/74, 50/79, 50/94, 52/94, 8079-002, 8093-002, 8094-002, and 82/94 expansion units](#) for details.

This ends the procedure.

**Parent topic:** [Removing and replacing parts in the 50/88 and 05/88 expansion units](#)

---

## Removing and replacing parts in the 50/94, 52/94, and 82/94 expansion units

Use this information to exchange parts in the 50/94, 52/94, and 82/94 expansion units.

**DANGER**When working on or around the system, observe the following precautions:

Electrical voltage and current from power, telephone, and communication cables are hazardous. To avoid a shock hazard:

- Connect power to this unit only with the provided power cord. Do not use the provided power cord for any other product.
- Do not open or service any power supply assembly.
- Do not connect or disconnect any cables or perform installation, maintenance, or reconfiguration of this product during an electrical storm.
- The product might be equipped with multiple power cords. To remove all hazardous voltages, disconnect all power cords.
- Connect all power cords to a properly wired and grounded electrical outlet. Ensure that the outlet supplies proper voltage and phase rotation according to the system rating plate.
- Connect any equipment that will be attached to this product to properly wired outlets.
- When possible, use one hand only to connect or disconnect signal cables.
- Never turn on any equipment when there is evidence of fire, water, or structural damage.
- Disconnect the attached power cords, telecommunications systems, networks, and modems before you open the device covers, unless instructed otherwise in the installation and configuration procedures.
- Connect and disconnect cables as described in the following procedures when installing, moving, or opening covers on this product or attached devices.

To Disconnect:

1. Turn off everything (unless instructed otherwise).
2. Remove the power cords from the outlets.
3. Remove the signal cables from the connectors.
4. Remove all cables from the devices

To Connect:

1. Turn off everything (unless instructed otherwise).
2. Attach all cables to the devices.
3. Attach the signal cables to the connectors.
4. Attach the power cords to the outlets.
5. Turn on the devices.

(D005)

**Note:** The 52/94 expansion unit consists of two stacked 50/94 units. Use these 50/94 exchange procedures for a 52/94 unit. Service 8094-002 expansion units with these procedures also.

- **AC modules A01 and A02 (single line cord)**
- **AC modules A01 and A02 (dual line cord)**
- **Backplane CB1**
- **PCI adapter**
- **Cards (concurrent)**  
Use this procedure to remove or replace cards concurrently in the 50/74, 50/79, 50/94, 52/94, 8079-002, 8093-002, 8094-002, and 82/94 expansion units.
- **Cards (dedicated)**  
Use this procedure to remove or replace cards using dedicated maintenance in the 50/74, 50/79, 50/94, 52/94, 8079-002, 8093-002, 8094-002, and 82/94 expansion units.
- **Covers**
- **Device boards DB1 and DB2**  
Use this procedure to remove or replace a device board (DB1 and DB2) in the 50/94 and 82/94 expansion units.
- **Device board DB3**  
Use this procedure to remove or replace a device board (DB3) in the 50/94 and 82/94 expansion units.
- **Disk unit (concurrent)**  
Use this procedure to remove or replace a disk unit using concurrent maintenance in the 50/94 and 82/94 expansion units.
- **Disk unit (dedicated)**  
Use this procedure to remove or replace a disk unit using dedicated maintenance in the 50/94 and

82/94 expansion units.

- [Control panel NB1](#)
- [Fans B01 and B02](#)
- [Power distribution backplane PB1](#)
- [Power supplies P00, P01, P02, and P03](#)
- [Removable media D41 and D42](#)

Use this procedure to remove or replace removable media (D41 and D42) in the 50/94 and 82/94 expansion units.

**Parent topic:** [Removing and replacing parts](#)

---

## Exchanging ac modules in the 50/94 and 82/94 expansion units (single line cord)

Use this procedure to remove or replace an ac module (A01 and A02) in the single line cord 50/94 and 82/94 expansion units.

1. Is the system or expansion unit with the failing ac module powered on?
  - ◆ Yes: Continue with the next step.
  - ◆ No: Go to step 3.
2. Is the failing ac module in location A02 (see [Locations 50/94, 52/94, 8094-002, 82/94, and 91/94 expansion unit](#))?
  - ◆ No: The failing ac module is in location A01. Power off the system (see [Powering on and powering off](#)) and continue with the next step.
  - ◆ Yes: Do not power off the system or expansion unit if it is powered on; this procedure can be performed concurrently. Continue with the next step.
3. Open the rear cover (see [Exchanging the covers in the 50/74, 50/79, 50/94, 52/94, 8079-002, 8093-002, 8094-002, and 82/94 expansion units](#)).
4. Trace and disconnect the ac input line cord that connects to the ac module that needs replacing (see [Locations 50/94, 52/94, 8094-002, 82/94, and 91/94 expansion unit](#)).

**Attention:** Do not disconnect the other nonfailing unit ac line cord when powered on.

5. Disconnect the power supply jumper cords from the ac module that you are working on.

**Attention:** Do not disconnect the other system ac module power supply jumper cords.

6. Remove the top and bottom screws that hold the ac module to the expansion unit.
7. Remove the ac module unit.
8. Install the new ac module by reversing this procedure.

**Note:** Do not install power supplies P00 and P01 ac jumper cables on the same ac input module.

9. After exchanging the module, go to [Verifying the repair](#). This ends the procedure.

**Parent topic:** [Removing and replacing parts in the 50/94, 52/94, and 82/94 expansion units](#)

---

## Exchanging disk units (concurrent) in the 50/94 and 82/94 expansion units

Use this procedure to remove or replace a disk unit using concurrent maintenance in the 50/94 and 82/94 expansion units.

**Attention:** If you are removing the cover while the expansion unit is powered on, errors may occur due to electromagnetic interference.

**Attention:** The disk unit is sensitive to electrostatic discharge (see [Working with electrostatic discharge-sensitive parts](#)).

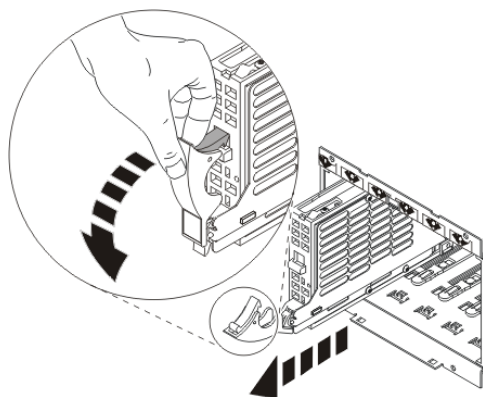
1. Determine if the system has logical partitions before continuing with this procedure (see [Determining if the system has logical partitions](#)).
2. Were you directed here from the [Disk unit recovery procedures](#)?
  - ◆ No: Go to [Disk unit recovery procedures](#).
  - ◆ Yes: After you have determined the location of the disk unit to replace, remove the front covers for access (see [Exchanging the covers in the 50/74, 50/79, 50/94, 52/94, 8079-002, 8093-002, 8094-002, and 82/94 expansion units](#)). Then continue with the next step.
3. Remove the EMC access plate that is at the location of the disk unit that you are removing.
4. To remove the disk unit perform the following:
  - a. Select System Service Tools (SST). If you cannot get to SST, select DST.

**Attention:** Do not perform a system IPL to get to DST.

- b. Select Start a Service Tool > Hardware Service Manager.
- c. Select Device Concurrent Maintenance and enter the required information in the information fields.
- d. Press Enter on the console. After the delay time, the light above the device location will begin flashing. You now have 9 seconds to pinch the two surfaces of the latching mechanism together and rotate the handle of the disk unit towards you. Pull the disk unit partially out of the tower. The light above the device location will go off and remain off as soon as the device is no longer making contact with the backplane.

**Attention:** If you remove the device when the light is not flashing, data might be lost, the disk unit might be damaged, or the backplane might be damaged.





Wait another 5 seconds to allow time for the disk to stop spinning. Then pull the disk unit the remaining way out of the tower.

5. Are you finished with the repair?
  - ◆ No: Continue with the next step.
  - ◆ Yes: Replace the covers that were removed during this procedure, and return to the procedure that sent you here. This ends the procedure.
6. Install the new disk unit by performing the following:
  - a. Select System Service Tools (SST). If you cannot get to SST, select DST.

**Attention:** Do not perform a system IPL to get to DST.

- b. Select Start a Service Tool > Hardware Service Manager.
- c. Select Device Concurrent Maintenance and enter the required information in the information fields.

**Attention:** Do not press Enter at this time.

- d. Slide the unit halfway into the tower. Ensure that the device does not make contact with the backplane at this time.
- e. Press Enter on the console. After the delay time, the light above the device location will begin flashing. You now have 9 seconds to insert the disk unit:
  - i. Put the disk unit part way into the desired slot and rotate the handle of the disk unit towards you.
  - ii. Push the disk unit completely into the slot, and rotate the handle towards the disk unit to latch it into the slot. The light above the device location will go off and remain off for a few seconds when the device contacts the backplane. Then it should go on and remain on.

**Attention:** If you install the device when the light is not flashing, data may be lost, the disk unit may be damaged, or the backplane may be damaged.

- f. Replace the covers that were removed during this procedure and return to the procedure that sent you here. This ends the procedure.

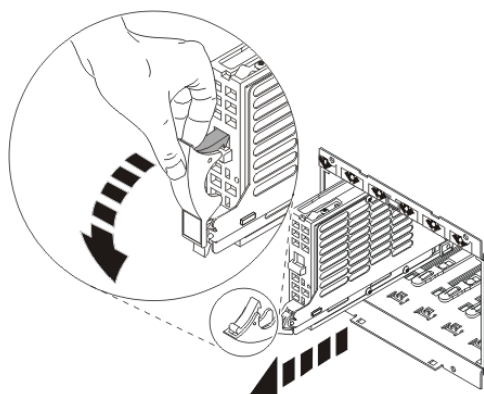
**Parent topic:** [Removing and replacing parts in the 50/94, 52/94, and 82/94 expansion units](#)

## Exchanging disk units (dedicated) in the 50/94 and 82/94 expansion units

Use this procedure to remove or replace a disk unit using dedicated maintenance in the 50/94 and 82/94 expansion units.

**Attention:** The disk unit is sensitive to electrostatic discharge (see [Working with electrostatic discharge-sensitive parts](#)).

1. Determine if the system has logical partitions before continuing with this procedure (see [Determining if the system has logical partitions](#)).
2. Were you directed here from the [Disk unit recovery procedures](#)?
  - ◆ No: Go to [Disk unit recovery procedures](#).
  - ◆ Yes: After you have determined the location of the disk unit to replace, remove the front covers for access (see [Exchanging the covers in the 50/74, 50/79, 50/94, 52/94, 8079-002, 8093-002, 8094-002, and 82/94 expansion units](#)). Then continue with the next step.
3. Remove the EMC access plate that is over the location of the disk unit that you are removing (see [Locations 50/94, 52/94, 8094-002, 82/94, and 91/94 expansion unit](#)).
4. Remove the disk unit by performing the following:
  - a. Power off the system (see [Powering on and powering off](#)).
  - b. Disconnect the power cord.
  - c. Pinch the two surfaces of the latching mechanism together and pull the handle towards you to release the disk unit from the slot.
  - d. Remove the disk unit from the tower.



5. Are you finished with the repair?
  - ◆ No: Continue with the next step.
  - ◆ Yes: Replace the covers that were removed during this procedure and return to the procedure that sent you here. This ends the procedure.
6. Install the disk unit by performing the following:
  - a. Power off the system (see [Powering on and powering off](#)).
  - b. Disconnect the power cord.
  - c. Put the disk unit partially into the desired slot, and rotate the handle of the disk unit towards you.
  - d. Push the disk unit completely into the slot and rotate the handle towards the disk unit to latch it into the slot.
  - e. Replace the covers that were removed during this procedure and return to the procedure that sent you here. This ends the procedure.

**Parent topic:** [Removing and replacing parts in the 50/94, 52/94, and 82/94 expansion units](#)

## Exchanging removable media in the 50/94 and 82/94 expansion units

Use this procedure to remove or replace removable media (D41 and D42) in the 50/94 and 82/94 expansion units.

**CAUTION:**This product might contain one or more of the following devices: CD-ROM drive, DVD-ROM drive, DVD-RAM drive, or laser module, which are Class 1 laser products. Note the following information:

- Do not remove the covers. Removing the covers of the laser product could result in exposure to hazardous laser radiation. There are no serviceable parts inside the device.
- Use of the controls or adjustments or performance of procedures other than those specified herein might result in hazardous radiation exposure.

(C026)

**CAUTION:**Some laser products contain an embedded Class 3A or Class 3B laser diode. Note the following information: laser radiation when open. Do not stare into the beam, do not view directly with optical instruments, and avoid direct exposure to the beam. (C030)

Perform the following to remove the removable media:

1. Determine if the system has logical partitions before continuing with this procedure (see [Determining if the system has logical partitions](#)).
2. Remove media (if any) from the device. If the eject button on a tape device is failing, go to [Tape cartridge, manual removal](#), then continue with the next step of this procedure. If the eject button on a DVD-RAM device is failing and will not open, do not attempt manual removal of optical media at this time. For optical devices other than DVD-RAM, go to [Optical media \(CD-ROM, DVD-ROM, and DVD-RAM\) - manual removal](#), and then continue with the next step of this procedure.
3. Are you removing a unit by using device concurrent maintenance?
  - ◆ Yes: Continue with the next step.
  - ◆ No: Perform the following:
    - a. Power off the tower or expansion tower (see [Powering on and powering off](#)).
    - b. Disconnect the power cord from the tower or expansion tower.
    - c. Open the front cover (see [Exchanging the covers in the 50/74, 50/79, 50/94, 52/94, 8079-002, 8093-002, 8094-002, and 82/94 expansion units](#)).
    - d. Pull on the handles, which are located on each side of the unit, and remove the unit. If the unit is DVD-RAM, and manual removal of optical media is required, go to [Optical media \(CD-ROM, DVD-ROM, and DVD-RAM\) - manual removal](#).
    - e. Install the new device by reversing this removal procedure. After exchanging an item, go to [Verifying the repair](#).

**Notes:**

- i. If you need to remove a tape from the old tape unit, see [Tape cartridge, manual removal](#).
- ii. If you need to remove optical media from an optical device, go to [Optical media \(CD-ROM, DVD-ROM, and DVD-RAM\) - manual removal](#).

This ends the procedure.

4. Before exchanging a removable media unit, you must ensure that the unit is not in use and is varied off.

**Note:** If you are removing an optical storage unit, you must ensure that all of the removable media units in the tower or expansion tower are not in use and are varied off.

5. Use the figure to determine the location of the internal removable media unit. Record this location for later use.

Figure 1. Internal removable media locations

|                 |
|-----------------|
| Position<br>D42 |
| Position<br>D41 |

R7APA503-1

## 6. Perform the following:

- a. Select System Service Tools (SST). If you cannot get to SST, select DST.

Do not perform a system IPL to get to DST.

- b. Select Start a Service Tool > Hardware Service Manager > Device Concurrent Maintenance and enter the required information in the information fields. *Do not press the Enter key at this time.*
- c. Read the remaining steps of this procedure and ensure that you understand the procedure before continuing.
- d. Press the Enter key on the console. After the delay time, the light at the top right of the device will begin flashing. You now have 9 seconds to pull firmly on the handles and pull the unit partially out of the tower.

**Attention:** If you remove the device when the light is *not* flashing, data may be lost, the unit may be damaged, or the backplane may be damaged.

**Note:** The light at the top right of the device will go off and remain off as soon as the device is no longer making contact with the backplane.

- e. Remove the unit from the tower.
  - ◇ If you need to remove a tape from the old tape unit, see [Tape cartridge, manual removal](#).
  - ◇ If you need to remove optical media from an optical device, go to [Optical media \(CD-ROM, DVD-ROM, and DVD-RAM\) - manual removal](#).

This ends the procedure.

**Parent topic:** [Removing and replacing parts in the 50/94, 52/94, and 82/94 expansion units](#)

## Replace removable media

Perform the following to replace the removable media:

1. Perform the following to install a new unit:
  - a. Select Device Concurrent Maintenance and enter the required information in the information fields. *Do not press the Enter key at this time.*
  - b. Read the remaining steps of this procedure and ensure that you understand the procedure before continuing.
  - c. Slide the unit partially into the tower. Ensure that the device does not contact the backplane at this time.

**Attention:** If you install the device when the light is not flashing, data may be lost, the unit may be damaged, or the backplane may be damaged.

- d. Press the Enter key on the console. After the delay time, the light at the top right of the device will begin flashing. You now have 9 seconds to push in firmly on the handles and push the

unit completely into the frame.

**Note:** The light at the top right of the device will go off and remain off for a few seconds when the device contacts the backplane. Then it should go on and remain on.

Did the light on the device go on and remain on?

◇ No: Continue with the next step.

◇ Yes: After exchanging an item, go to [Verifying the repair](#). This ends the procedure.

2. Attempt the device concurrent maintenance procedure again without physically moving the unit.

Did the light above the device go on and remain on?

◆ No: Continue with the next step.

◆ Yes: After exchanging an item, go to [Verifying the repair](#). This ends the procedure.

3. There is a power problem. One of the following is the problem:

◆ The new unit is defective.

◆ The backplane was damaged during the device concurrent maintenance procedure.

◆ There is a new problem with the power subsystem. This ends the procedure.

## Removing and replacing parts in the 50/95, 05/95, and 11D/20 expansion units

Use this information to exchange parts in the 50/95, 05/95, and 11D/20 expansion units.

### **DANGER**When working on or around the system, observe the following precautions:

Electrical voltage and current from power, telephone, and communication cables are hazardous. To avoid a shock hazard:

- Connect power to this unit only with the provided power cord. Do not use the provided power cord for any other product.
- Do not open or service any power supply assembly.
- Do not connect or disconnect any cables or perform installation, maintenance, or reconfiguration of this product during an electrical storm.
- The product might be equipped with multiple power cords. To remove all hazardous voltages, disconnect all power cords.
- Connect all power cords to a properly wired and grounded electrical outlet. Ensure that the outlet supplies proper voltage and phase rotation according to the system rating plate.
- Connect any equipment that will be attached to this product to properly wired outlets.
- When possible, use one hand only to connect or disconnect signal cables.
- Never turn on any equipment when there is evidence of fire, water, or structural damage.
- Disconnect the attached power cords, telecommunications systems, networks, and modems before you open the device covers, unless instructed otherwise in the installation and configuration procedures.
- Connect and disconnect cables as described in the following procedures when installing, moving, or opening covers on this product or attached devices.
  - To Disconnect:
    1. Turn off everything (unless instructed otherwise).
    2. Remove the power cords from the outlets.
    3. Remove the signal cables from the connectors.
    4. Remove all cables from the devices

To Connect:

1. Turn off everything (unless instructed otherwise).
2. Attach all cables to the devices.
3. Attach the signal cables to the connectors.
4. Attach the power cords to the outlets.
5. Turn on the devices.

(D005)

- [Control panel](#)
- [Covers](#)
- [Disk drive](#)
- [Disk drive backplane](#)
- [Fan](#)

Use this procedure to remove or replace a fan or air moving device (AMD) in the 50/95, 05/95, and 11D/20 expansion units.

- [I/O backplane assembly](#)
- [PCI adapter](#)
- [Power supply](#)
- [RIO/HSL card](#)

Parent topic: [Removing and replacing parts](#)

---

## Exchanging covers in the 50/95 and 05/95 expansion units

Use this procedure to remove or replace the covers in the 50/95 and 05/95 expansion units.

To remove the front cover: Pull the top of the cover away from the frame.

To remove the right side cover: Lift up on the latch and slide the cover to the rear of the unit.

To remove the rear cover: Lift the cover to detach.

Parent topic: [Removing and replacing parts in the 50/95, 05/95, and 11D/20 expansion units](#)

---

## Removing and replacing parts in the 57/86, 57/87, D24, and T24 expansion units

Use this information to exchange parts in the 57/86, 57/87, D24, and T24 expansion units.

### **DANGER**When working on or around the system, observe the following precautions:

Electrical voltage and current from power, telephone, and communication cables are hazardous. To avoid a shock hazard:

- Connect power to this unit only with the provided power cord. Do not use the provided power cord for any other product.
- Do not open or service any power supply assembly.
- Do not connect or disconnect any cables or perform installation, maintenance, or reconfiguration of this product during an electrical storm.
- The product might be equipped with multiple power cords. To remove all hazardous voltages, disconnect all power cords.

- Connect all power cords to a properly wired and grounded electrical outlet. Ensure that the outlet supplies proper voltage and phase rotation according to the system rating plate.
- Connect any equipment that will be attached to this product to properly wired outlets.
- When possible, use one hand only to connect or disconnect signal cables.
- Never turn on any equipment when there is evidence of fire, water, or structural damage.
- Disconnect the attached power cords, telecommunications systems, networks, and modems before you open the device covers, unless instructed otherwise in the installation and configuration procedures.
- Connect and disconnect cables as described in the following procedures when installing, moving, or opening covers on this product or attached devices.

To Disconnect:

1. Turn off everything (unless instructed otherwise).
2. Remove the power cords from the outlets.
3. Remove the signal cables from the connectors.
4. Remove all cables from the devices

To Connect:

1. Turn off everything (unless instructed otherwise).
2. Attach all cables to the devices.
3. Attach the signal cables to the connectors.
4. Attach the power cords to the outlets.
5. Turn on the devices.

(D005)

#### Notes:

1. For most parts on a 57/86, 57/87, D24, and T24 expansion unit, the removal and replacement procedures are customer tasks and can be found in the [Installing hardware](#) topic.
2. Refer to the installation instructions that were provided with the chassis assembly FRU (field replaceable unit) for the chassis assembly FRU removal and replacement procedures.

- [Exchanging the model 57/86 chassis](#)
- [Disk drive](#)
- [Exchanging the 57/86, 57/87, D24, and T24 SCSI disk drive enclosure fans](#)  
Replace SCSI disk drive enclosure fans for expansion units.
- [Power supply](#)

Parent topic: [Removing and replacing parts](#)

---

## Exchanging the model 57/86 chassis

To exchange the chassis on the model 57/86, perform the following procedure:

1. If you are removing the chassis as part of another procedure, continue to the next step. If you are removing the system backplane because it is not operational, verify that it is the failing part. See [Identify a failing part](#).
2. Perform the following to prepare the system:
  - a. Ensure that the customer has taken appropriate actions to remove the server from normal use.
  - b. Power off the system. For instructions, see [Stopping the system](#).
  - c. Disconnect the power source from the system.

**Note:** This system might be equipped with a second power supply. Before continuing with this procedure, ensure that the power source to the system has been completely disconnected.

- d. Attach a wrist strap to a metal surface of your hardware to prevent electrostatic discharge from damaging your hardware. If you do not have a wrist strap, touch a metal surface of the system before installing or replacing hardware.

**Note:** Follow the same precautions that you would use if you were not using the wrist strap. A wrist strap is for static control. It will not increase or decrease your risk of receiving electric shock when using or working on electrical equipment.

3. Remove all of the cables from the back of the system unit.
4. Remove the service access cover.
5. Remove the fans. See [Fans](#).
6. Remove the device enclosure.
7. Remove the disk drives. Mark their order and location. See [Disk drive](#).
8. To insert a chassis, reverse the steps in this procedure.
9. If you replaced the chassis as part of another procedure, return to that procedure now. If you replaced it because it was not operational, verify that the new resource is functional. See [Verifying the repair](#).

**Parent topic:** [Removing and replacing parts in the 57/86, 57/87, D24, and T24 expansion units](#)

---

## Exchanging the 57/86, 57/87, D24, and T24 SCSI disk drive enclosure fans

Replace SCSI disk drive enclosure fans for expansion units.

**CAUTION:**This assembly contains mechanical moving parts. Use care when servicing this assembly.

**CAUTION:**Service of this product or unit is to be performed by trained service personnel only. (C032)

(L008)



Use this procedure to remove and replace the 57/86, 57/87, D24, and T24 SCSI disk drive enclosure fan.

1. This procedure can be done with the power on.
2. Locate the fan assembly on the front of the expansion unit and a slide bar that secures the fans.
3. Unscrew the slide bar's thumbscrew, and slide the slide bar to the side.
4. Pull the fan assembly straight out until it is clear of the expansion unit.
5. To replace the fan assembly, reverse this removal procedure.



## Removing and replacing parts in the 57/91, 57/94, and 406/1D expansion units

Use this information to exchange parts in the 57/91, 57/94, and 406/1D expansion units.

### **DANGER**When working on or around the system, observe the following precautions:

Electrical voltage and current from power, telephone, and communication cables are hazardous. To avoid a shock hazard:

- Connect power to this unit only with the provided power cord. Do not use the provided power cord for any other product.
- Do not open or service any power supply assembly.
- Do not connect or disconnect any cables or perform installation, maintenance, or reconfiguration of this product during an electrical storm.
- The product might be equipped with multiple power cords. To remove all hazardous voltages, disconnect all power cords.
- Connect all power cords to a properly wired and grounded electrical outlet. Ensure that the outlet supplies proper voltage and phase rotation according to the system rating plate.
- Connect any equipment that will be attached to this product to properly wired outlets.
- When possible, use one hand only to connect or disconnect signal cables.
- Never turn on any equipment when there is evidence of fire, water, or structural damage.
- Disconnect the attached power cords, telecommunications systems, networks, and modems before you open the device covers, unless instructed otherwise in the installation and configuration procedures.
- Connect and disconnect cables as described in the following procedures when installing, moving, or opening covers on this product or attached devices.
  - To Disconnect:
    1. Turn off everything (unless instructed otherwise).
    2. Remove the power cords from the outlets.
    3. Remove the signal cables from the connectors.
    4. Remove all cables from the devices

To Connect:

1. Turn off everything (unless instructed otherwise).
2. Attach all cables to the devices.
3. Attach the signal cables to the connectors.
4. Attach the power cords to the outlets.
5. Turn on the devices.

(D005)

**Note:** For some parts in the 57/91, 57/94, and 406/1D expansion units, the removal and replacement procedures are customer tasks and can be found in the [Installing hardware](#) topic. Use the following links to go directly to these procedures.

[Disk drive](#)

[PCI adapter](#)

For all other parts, use the Service focal point application on the Hardware Management Console (HMC) to find information about how to remove and replace parts. Do the following to access the Service focal point application:

1. Log into the HMC as the service representative.
2. In the Navigation area, select the Service Applications icon.
3. Select the Service Focal Point icon.
4. Select Exchange Parts. The Exchange Parts window opens. Follow the instructions on the Exchange Parts window until you reach the removal and replacement procedures for the selected part.

Parent topic: [Removing and replacing parts](#)

---

## Removing and replacing parts in the 57/95 expansion unit

Use this information to exchange parts in the 57/95 expansion unit.

### **DANGER**When working on or around the system, observe the following precautions:

Electrical voltage and current from power, telephone, and communication cables are hazardous. To avoid a shock hazard:

- Connect power to this unit only with the provided power cord. Do not use the provided power cord for any other product.
- Do not open or service any power supply assembly.
- Do not connect or disconnect any cables or perform installation, maintenance, or reconfiguration of this product during an electrical storm.
- The product might be equipped with multiple power cords. To remove all hazardous voltages, disconnect all power cords.
- Connect all power cords to a properly wired and grounded electrical outlet. Ensure that the outlet supplies proper voltage and phase rotation according to the system rating plate.
- Connect any equipment that will be attached to this product to properly wired outlets.
- When possible, use one hand only to connect or disconnect signal cables.
- Never turn on any equipment when there is evidence of fire, water, or structural damage.
- Disconnect the attached power cords, telecommunications systems, networks, and modems before you open the device covers, unless instructed otherwise in the installation and configuration procedures.
- Connect and disconnect cables as described in the following procedures when installing, moving, or opening covers on this product or attached devices.
  - To Disconnect:
    1. Turn off everything (unless instructed otherwise).
    2. Remove the power cords from the outlets.
    3. Remove the signal cables from the connectors.
    4. Remove all cables from the devices

To Connect:

1. Turn off everything (unless instructed otherwise).
2. Attach all cables to the devices.
3. Attach the signal cables to the connectors.
4. Attach the power cords to the outlets.
5. Turn on the devices.

(D005)

- [57/95 expansion unit](#)

- [57/95 media device](#)

Parent topic: [Removing and replacing parts](#)

---

## 57/95 expansion unit

1. Perform the following to prepare the system:
  - a. Ensure that the customer has taken appropriate actions to remove the server from normal use.
  - b. Power off the system. For instructions, see [Stopping the system](#).
  - c. Disconnect the power source from the system.

**Note:** This system might be equipped with a second power supply. Before continuing with this procedure, ensure that the power source to the system has been completely disconnected.

- d. Attach a wrist strap to a metal surface of your hardware to prevent electrostatic discharge from damaging your hardware. If you do not have a wrist strap, touch a metal surface of the system before installing or replacing hardware.

**Note:** Follow the same precautions that you would use if you were not using the wrist strap. A wrist strap is for static control. It will not increase or decrease your risk of receiving electric shock when using or working on electrical equipment.

2. Label and disconnect all cables from the rear of the 57/95 expansion unit.
3. Loosen the thumbscrews that hold the 57/95 expansion unit to the rack.
4. Slide the 57/95 expansion unit out of the rack.
5. To insert the 57/95 expansion unit, reverse the steps in this procedure.
6. If you replaced the 57/95 expansion unit because it was not operational, verify that the new resource is functional. See [Verifying the repair](#). This ends the procedure.

Parent topic: [Removing and replacing parts in the 57/95 expansion unit](#)

---

## 57/95 media device

1. Perform the following to prepare the system:
  - a. Ensure that the customer has taken appropriate actions to remove the server from normal use.
  - b. Power off the system. For instructions, see [Stopping the system](#).
  - c. Disconnect the power source from the system.

**Note:** This system might be equipped with a second power supply. Before continuing with this procedure, ensure that the power source to the system has been completely disconnected.

- d. Attach a wrist strap to a metal surface of your hardware to prevent electrostatic discharge from damaging your hardware. If you do not have a wrist strap, touch a metal surface of the system before installing or replacing hardware.

**Note:** Follow the same precautions that you would use if you were not using the wrist strap. A wrist strap is for static control. It will not increase or decrease your risk of receiving electric shock when using or working on electrical equipment.

2. Loosen the thumbscrew of the media device that you want to remove.
3. Slide the media device out of the expansion unit.
4. Disconnect the power cable at the rear of the media device.
5. Disconnect the SCSI cable at the rear of the media device.
6. Remove the screws that attach the media device to the carrier assembly.
7. To insert a media device, reverse the steps in this procedure.
8. If you replaced the media device because it was not operational, verify that the new resource is functional. See [Verifying the repair](#). This ends the procedure.

**Parent topic:** [Removing and replacing parts in the 57/95 expansion unit](#)

---

## Removing and replacing parts in the 11D/11 and 57/90 expansion units

Use this information to exchange parts in the 11D/11 and 57/90 expansion units.

**Note:** Refer to the [11D/10 service guide](#) for 11D/10 removal and replacement information.

### **DANGER**When working on or around the system, observe the following precautions:

Electrical voltage and current from power, telephone, and communication cables are hazardous. To avoid a shock hazard:

- Connect power to this unit only with the provided power cord. Do not use the provided power cord for any other product.
- Do not open or service any power supply assembly.
- Do not connect or disconnect any cables or perform installation, maintenance, or reconfiguration of this product during an electrical storm.
- The product might be equipped with multiple power cords. To remove all hazardous voltages, disconnect all power cords.
- Connect all power cords to a properly wired and grounded electrical outlet. Ensure that the outlet supplies proper voltage and phase rotation according to the system rating plate.
- Connect any equipment that will be attached to this product to properly wired outlets.
- When possible, use one hand only to connect or disconnect signal cables.
- Never turn on any equipment when there is evidence of fire, water, or structural damage.
- Disconnect the attached power cords, telecommunications systems, networks, and modems before you open the device covers, unless instructed otherwise in the installation and configuration procedures.
- Connect and disconnect cables as described in the following procedures when installing, moving, or opening covers on this product or attached devices.
  - To Disconnect:
    1. Turn off everything (unless instructed otherwise).
    2. Remove the power cords from the outlets.
    3. Remove the signal cables from the connectors.
    4. Remove all cables from the devices

To Connect:

1. Turn off everything (unless instructed otherwise).
2. Attach all cables to the devices.
3. Attach the signal cables to the connectors.
4. Attach the power cords to the outlets.
5. Turn on the devices.

(D005)

- [Remove the 11D/11 and 57/90 expansion unit front cover](#)
- [Place the 11D/11 and 57/90 expansion unit in the service position](#)
- [Remove the 11D/11 and 57/90 expansion unit service access cover](#)
- [PCI adapter](#)
- [Exchange the 11D/11 and 57/90 fan assembly](#)
- [Exchange the 11D/11 and 57/90 I/O backplane assembly](#)
- [Exchange the 11D/11 and 57/90 RIO card](#)
- [Exchange the 11D/11 and 57/90 power supply](#)

Parent topic: [Removing and replacing parts](#)

---

## Remove the 11D/11 and 57/90 expansion unit front cover

To remove the expansion unit front cover, do the following:

1. Open the front rack door.
2. Simultaneously press in both cover-release tabs.
3. Pivot the cover out from the top, swing the top forward.
4. Pull the bottom of the cover up, then away from the expansion unit chassis. This action releases the two tab hooks located on the bottom of the expansion unit chassis.
5. To replace the front cover, reverse this removal procedure.

Parent topic: [Removing and replacing parts in the 11D/11 and 57/90 expansion units](#)

---

## Place the 11D/11 and 57/90 expansion unit in the service position

Parent topic: [Removing and replacing parts in the 11D/11 and 57/90 expansion units](#)

### Place the expansion unit in the service position

To place the expansion unit in the service position, do the following:

1. Ensure that the system unit to which the expansion unit is connected is shut down.
2. From the back of the rack, disconnect the expansion unit's power cables from the power distribution bus.
3. Remove the retaining screws located on the back of the expansion unit.
4. Label and disconnect all of the cables connected to the back of the expansion unit.
5. From the back of the rack, pull the expansion unit straight out until the unit stops.
6. Press the stop latch on the side of the enclosure.
7. Support the expansion unit as you pull it out from the back of the rack.
8. Place the expansion unit on a stable work surface.

### Return the expansion unit to the operating position

To return the expansion unit to the operating position, do the following:

1. From the back of the rack, insert the expansion unit into the rack location from which it was removed. The end of the expansion unit that contains the power supplies goes toward the front of the rack.

2. Support the expansion unit as you push it toward the front of the rack.
3. Install the retaining screws in the back of the expansion unit.
4. Reconnect the cables to the back of the expansion unit.
5. Reconnect the power cables.
6. Restart the system.

---

## Remove the 11D/11 and 57/90 expansion unit service access cover

To remove the expansion unit service access cover, follow these steps:

1. Open the front rack door.
2. Place the expansion unit into the service position as described in [Place the 11D/11 and 57/90 expansion unit in the service position](#).
3. Loosen the two captive thumbscrews located on the back of the service access cover.
4. From the back of the expansion unit, lift the cover and slide it backwards until the front disengages. Lift the cover off the expansion unit.
5. To replace the expansion unit service access cover, reverse this removal procedure.

**Parent topic:** [Removing and replacing parts in the 11D/11 and 57/90 expansion units](#)

---

## Exchanging RIO cables

Use this procedure to replace the RIO cables concurrently. You will need to perform the following steps for both ends of the cable that you are replacing.

**Attention:** Depending on your operator system you may need to follow the [Power off, power on instructions](#) specific to your server.

**Note:** You do not need to power off the system or expansion unit. If you are replacing a cable between a system unit and an expansion unit, connect the expansion unit end of the cable first. This will reduce the chances of the problem identified in the previous warning from happening with the system unit however, the problem may still occur with the I/O unit in rare cases.

1. Disconnect the cable at the unit, card location, and port on which you are working. See the previous note.
2. Is the connection an optical link?
  - ◆ No: Wait at least 30 seconds.
  - ◆ Yes: Clean the RIO cable connectors on the new cables and the cable port using the tools and procedures listed in the symbolic FRU [OPTCLN](#). Continue with the next step.
3. Connect the new cable to the port.

**Attention:** For copper cables, you must fully connect the cable and tighten the connector's screws within 30 seconds of when the cable makes contact with the port. If you do not, the link will fail and you must disconnect and reconnect it again. If the connector screws are not tightened, errors will occur on the link and it will fail.

This ends the procedure.

**Parent topic:** [Removing and replacing parts](#)

### Power off, power on instructions

If you accidentally removed an RIO cable and lost RIO connections to frames that were in a loop, follow these steps.

1. From the Hardware Service Manager screen, select Packaging hardware resources.
2. Select the unit that has lost its RIO connection and select Concurrent maintenance. Then press *Enter*.
3. Select Power off domain to power off the unit tower.
4. After reconnecting the unit into the RIO loop, select Power on domain. This ends the procedure.

## HMC parts removal and replacement procedures

Customers can perform the removal and replacement procedures for most of the parts on their HMC personal computers. For more information about removing and replacing parts on the HMC, see [Removing and replacing parts on the HMC](#).

**Parent topic:** [Removing and replacing parts](#)

### Removing and replacing parts on type 2748, 2757, 2763, 2778, 2780, 2782, 4758, 4764, 5703, 5708, 5709, 571B, 571E, 571F, 573D, 574F, 575B

Use this information to exchange parts on type 2748, 2757, 2763, 2778, 2780, 2782, 4758, 4764, 5703, 5708, 5709, 571B, 571E, 571F, 573D, 574F, 575B cards, only when directed from another procedure.

- [Replacing the cache battery pack on type 2748, 2757, 2763, 2778, 2780, 2782, 5703, 5708, 5709, 571B, 571E, 571F, 573D, 574F, 575B cards](#)  
Use this procedure to remove or replace the cache battery pack from type 2748, 2757, 2763, 2778, 2780, 2782, 5703, 5708, 5709, 571B, 571E, 571F, 573D, 574F, 575B cards.
- [Separating the removable cache card from the base card on type 2780 and 571E cards](#)
- [Separating the 571F/575B card set and moving the cache directory card](#)
- [Remove / Install the cache directory card on type 2748, 2757, 2763, 2778, 2780, 2782, 5703, 5709, 571B, 571E, and 573D cards](#)
- [Replacing the battery on a type 4758 card](#)  
Use this procedure to remove or replace the PCI cryptographic coprocessor card batteries in type 4758.
- [Disabling the cryptographic coprocessor on a type 4758 card](#)
- [Replacing the battery on a type 4764 card](#)  
Use this procedure to remove or replace the type 4764 PCI cryptographic coprocessor card batteries.
- [Disabling the cryptographic coprocessor on a type 4764 card](#)

**Parent topic:** [Removing and replacing parts](#)

## Separating the removable cache card from the base card on type 2780 and 571E cards

To complete this procedure, you will need a T-10 TORX tool.

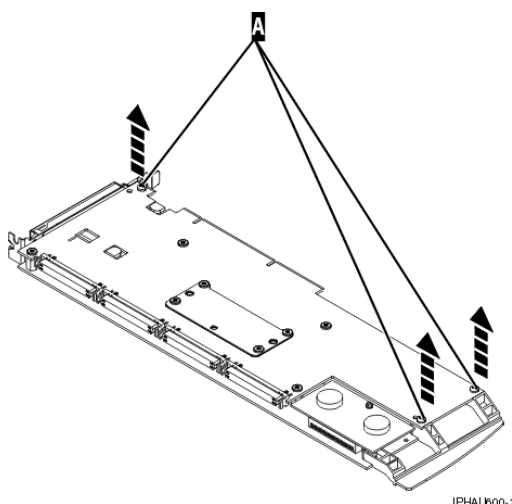
**Attention:** To avoid loss of cache data, *do not* disconnect the cache battery during this procedure.

To separate the removable cache card from the base card, do the following:

**Important:** All cards are sensitive to electrostatic discharge. See [Working with electrostatic discharge-sensitive parts](#).

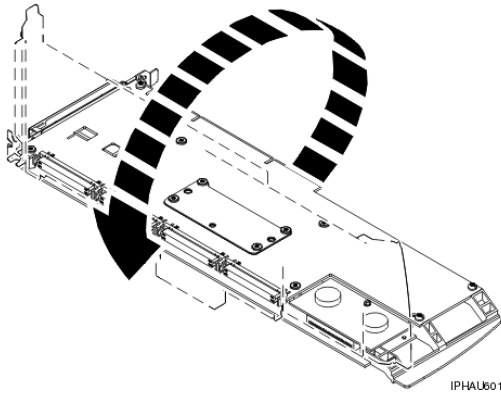
1. Label both sides of the card before separating the cache card from the base card.
2. Are you servicing a 2780 adapter or a 571E adapter?
  - ◆ If you are servicing a 2780 adapter, go to [step 3](#).
  - ◆ If you are servicing a 571E adapter, go to [step 9](#).
3. Place the 2780 adapter on an ESD protective surface and orient it as shown in the following graphic. Note the position of the card handle.
4. Remove the three screws A from the base card as shown.

**Tip:** Note the thread differences of the screws for correct screw replacement. The two screws that were secured into the plastic handle have a different thread pattern from the machine thread screw that was removed from the front of the card.

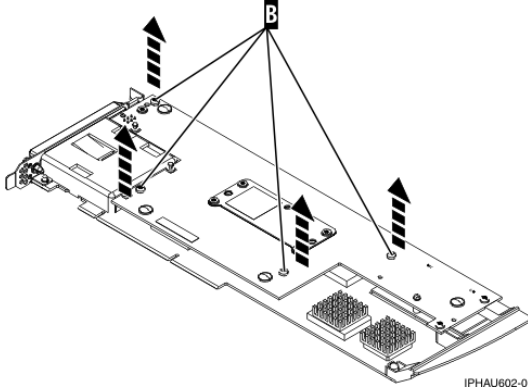


5. Turn the card over.

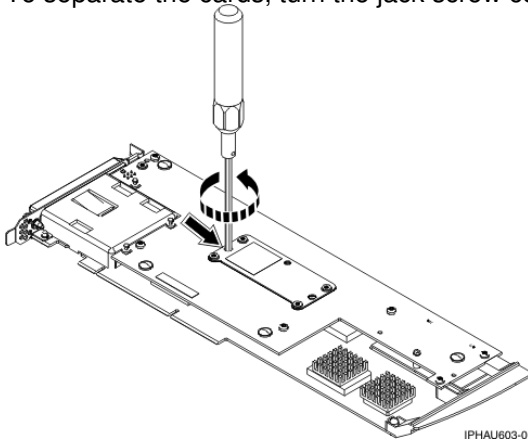




6. Remove the four screws B from the removable cache card as shown.



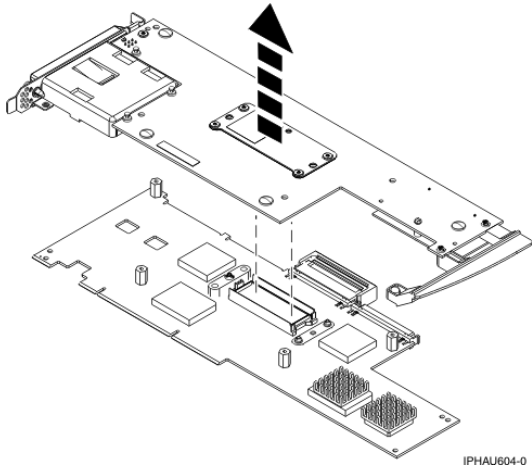
7. To separate the cards, turn the jack screw counterclockwise until you feel the cards separate.



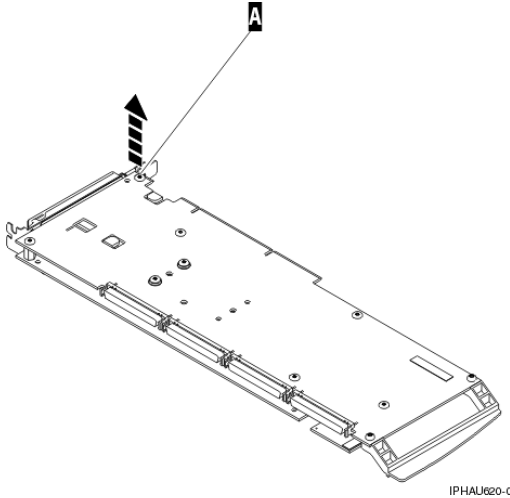
8. Separate the base card from the removable cache card.

**Important:** After separating the base card from the cache card, turn the jack screw clockwise to reset it.

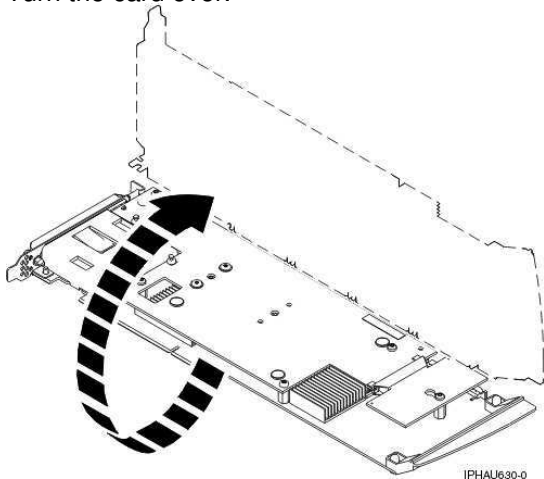
After you have reset the jack screw, go to [Attach the removable cache card to the base card.](#)



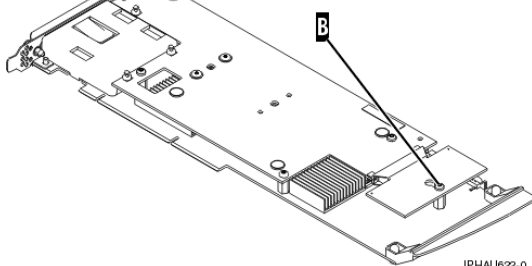
9. Place the 571E adapter on an ESD protective surface and orient it as shown in the following graphic. Note the position of the card handle.
10. Remove screw A from the base card as shown.



11. Turn the card over.

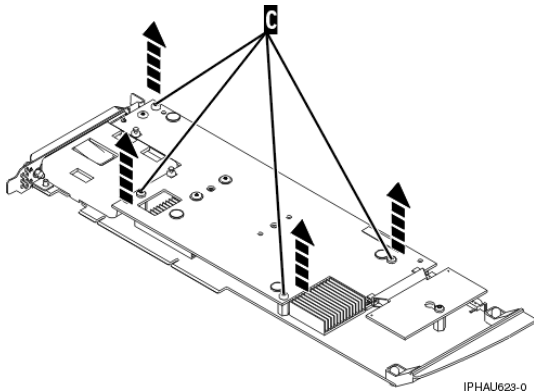


12. Loosen screw B one full turn. *Do not* remove this screw.

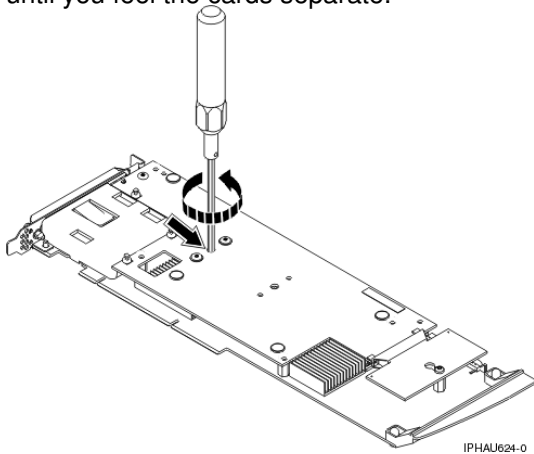


13. Remove the four screws C from the removable cache card as shown.

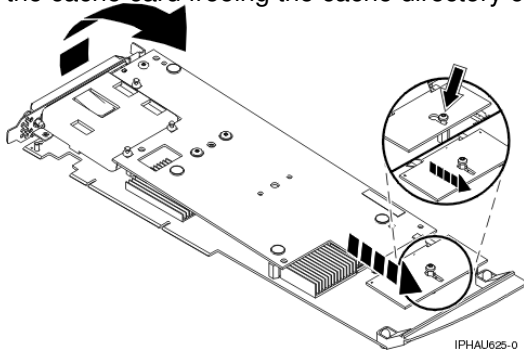
**Note:** Observe the keyhole slot located below screw B. In [step 15](#) when asked to separate the cache card, you will need to have the keyhole slot clear the retaining screw.



14. Turn the jack screw counterclockwise to begin separating the cards. Continue turning the jack screw until you feel the cards separate.

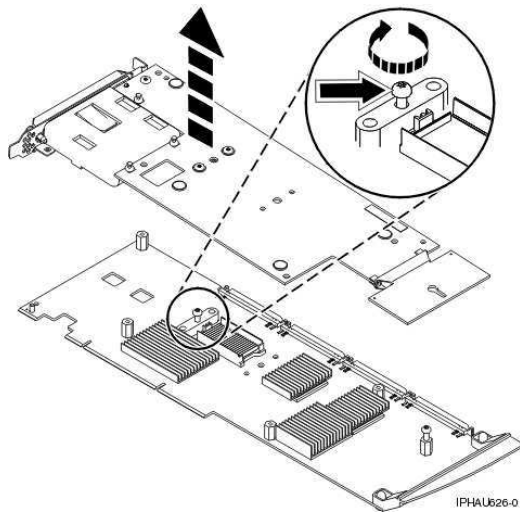


15. Carefully slide the removable cache card towards the plastic handle. Slightly lift up the back portion of the cache card freeing the cache directory card's keyhole slot from its retaining screw.



16. Separate the base card from the removable cache card.

**Important:** After separating the base card from the cache card, turn the jack screw clockwise to reset it.



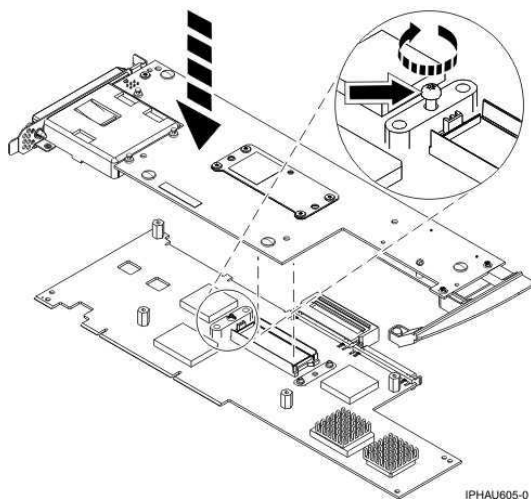
**Parent topic:** [Removing and replacing parts on type 2748, 2757, 2763, 2778, 2780, 2782, 4758, 4764, 5703, 5708, 5709, 571B, 571E, 571F, 573D, 574F, 575B](#)

### Attach the removable cache card to the base card

To attach the removable cache card to the base card, do the following:

1. Make sure the jack screw is turned clockwise until it is fully seated.

**Attention:** If the jack screw is not fully seated, the cards will not connect properly and damage may occur.

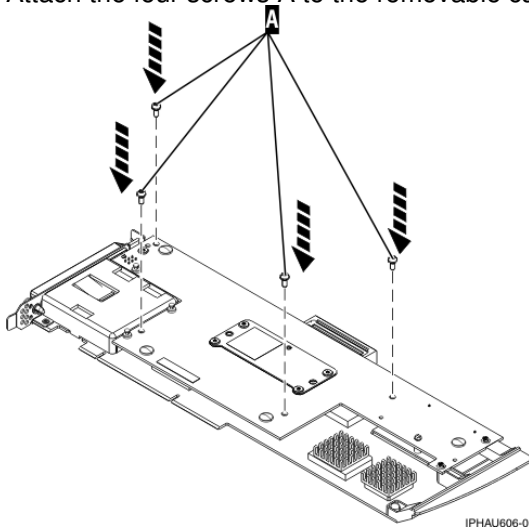


2. Are you servicing a 2780 adapter or a 571E adapter?
  - ◆ If you are servicing a 2780 adapter, go to [step 3](#).
  - ◆ If you are servicing a 571E adapter, go to [step 7](#).
3. Align then attach the 2780 base card to the removable cache card by doing the following:
  - a. Align the card connector.

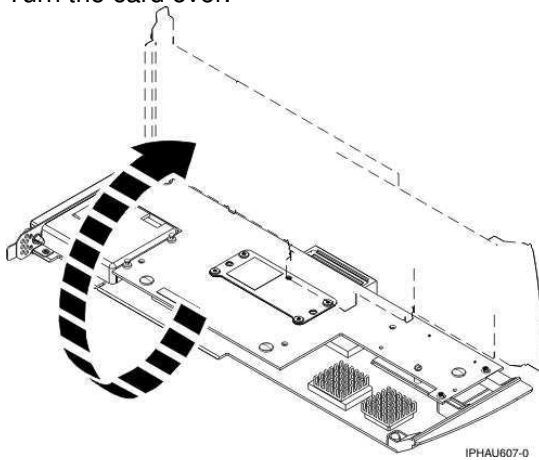
**Note:** To help align the card connector, view the jack screw through the hole.

- b. Press down on the stiffener plate to fully seat the connector.

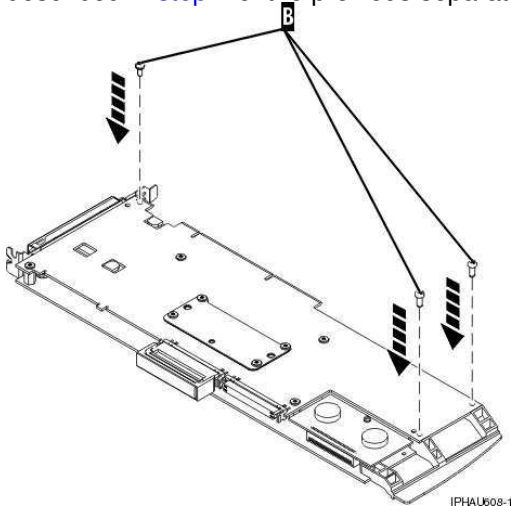
4. Attach the four screws A to the removable cache card as shown.



5. Turn the card over.

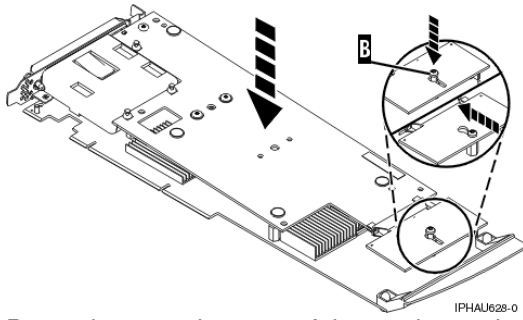


6. Attach the three screws B to the base card as shown. Note the thread differences in the screws as described in [step 4](#) of the previous separation procedure. This ends this procedure.

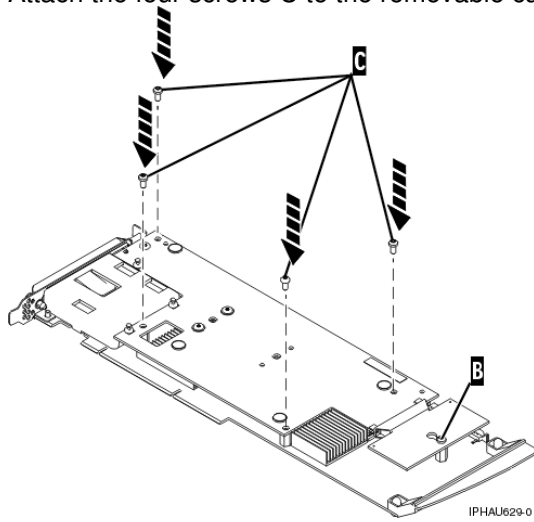


7. Attach the 571E base card to the removable cache card by doing the following:
- Align the removable cache card with the base card and place the hole in the cache directory card over the screw B.
  - Slide the removable cache card away from the plastic handle to line up the card connector. (view the jack screw through the hole to help alignment).

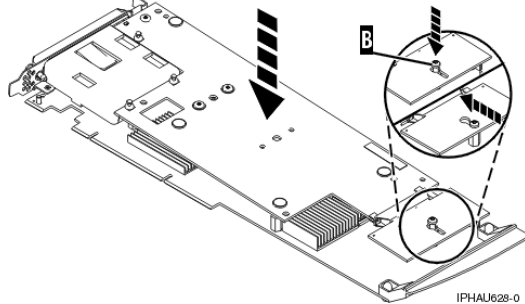
Service provider information



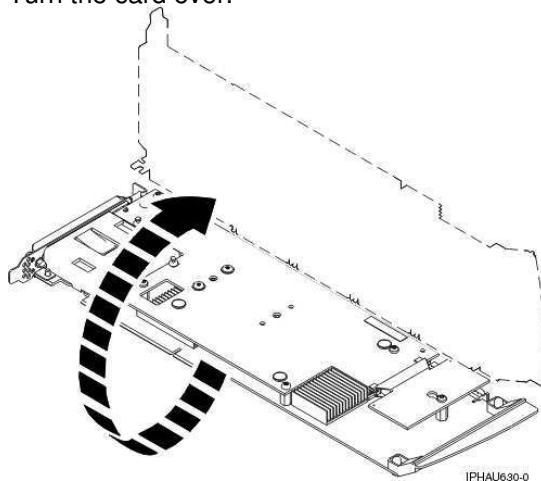
- c. Press down on the area of the card over the connector to fully seat the connector.  
8. Attach the four screws C to the removable cache card as shown.



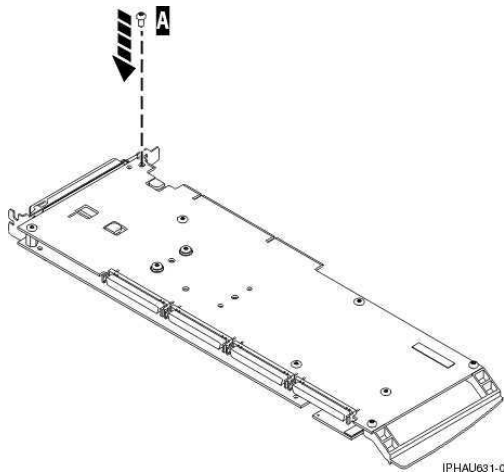
9. Tighten screw B on the cache directory card.



10. Turn the card over.



11. Attach the screw A to the base card.



## Remove / Install the cache directory card on type 2748, 2757, 2763, 2778, 2780, 2782, 5703, 5709, 571B, 571E, and 573D cards

**Important:** All cards are sensitive to electrostatic discharge. Read [Working with electrostatic discharge-sensitive parts](#) before performing this procedure.

1. Is the cache directory card on a type 5709 or 573D (RAID enablement) card?
  - ◆ No: Continue with the next step.
  - ◆ Yes: Remove the RAID enablement card using one of the following procedures, then go to step [step 7](#):
    - ◇ For model 5/20: [Remove the model ESCALA PL 250T/R RAID enablement card](#)
    - ◇ For model 5/70: [Exchanging the RAID enablement card in the model ESCALA PL 1650R-L+ and ESCALA PL 850R/PL 1650R/R+](#)
2. Remove the card using the concurrent card removal and replacement procedure for the model or expansion unit that you are working on (see [Removing and replacing parts](#)).
3. Choose one of the following:
  - ◆ For type 2748, 2763, and 2778 cards, continue with the next step.
  - ◆ For type 2757, 2780, 2782, 5703, 5709, 571B, and 573D cards, go to step [step 7](#).
  - ◆ For type 571E cards, go to [step 10](#).
4. Locate the cache directory card B. It is a small rectangular card mounted on the I/O card (see [Figure 1](#)).

Spread the tabs on each side of the cache directory card, and raise the back of the cache directory card B up and away from the I/O card. The cache directory card will pivot up about 20 degrees.

5. Pull the cache directory card out.
6. Install the replacement cache directory card by wiggling it into place at a 20-degree angle before pushing it down and locking the tabs. Be sure that the holes on each side of the cache directory card are filled by the pegs on the cache card to ensure proper seating. This ends the procedure.
7. Locate the cache directory card B. It is a small rectangular card mounted on the I/O card (see [Figure 2](#), [Figure 3](#), [Figure 4](#), [Figure 5](#) or [Figure 6](#)).
8. Unseat the connector on the cache directory card by wiggling the two corners that are farthest from the mounting peg by using a rocking motion. Then, pivot the cache directory card back over the mounting peg to disengage the cache directory card from the mounting peg.

**Note:** For the type 2757 card, do not remove the larger card with the two mounting pegs.

9. Install the replacement card by seating it on the connector and mounting peg. **This ends the procedure.**

Figure 1. Cache battery pack and cache directory card for type 2748, 2763, and 2778

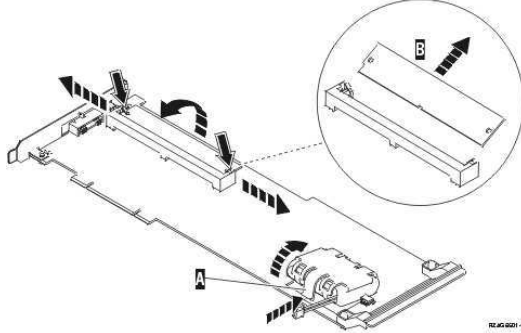


Figure 2. Cache battery pack and cache directory card for type 2757

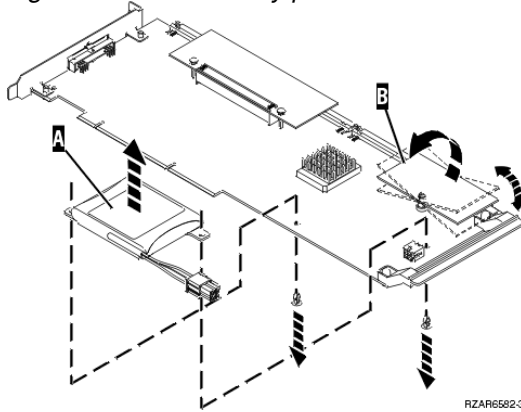


Figure 3. Cache battery pack and cache directory card for type 2782, and 5703

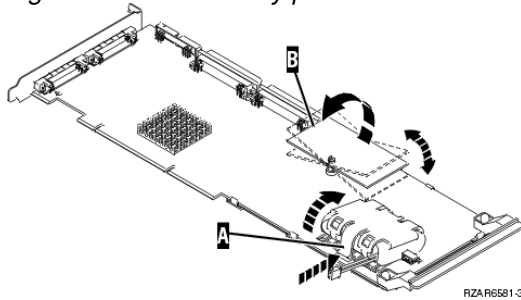


Figure 4. Cache battery pack and cache directory card for type 5709 and 573D

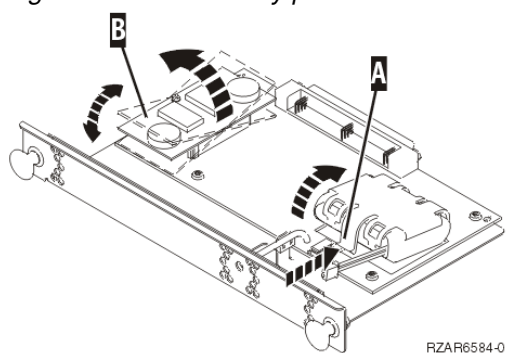




Figure 5. Cache battery pack and cache directory card for type 2780 (style A)

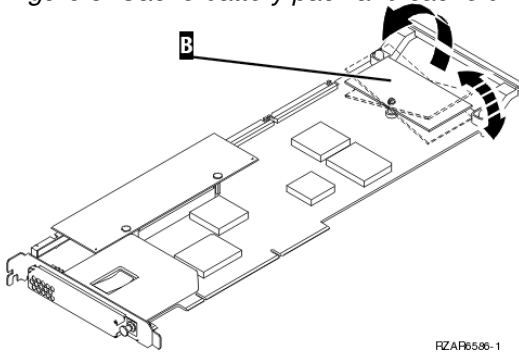


Figure 6. Cache battery pack and cache directory card for type 2780 (style B)

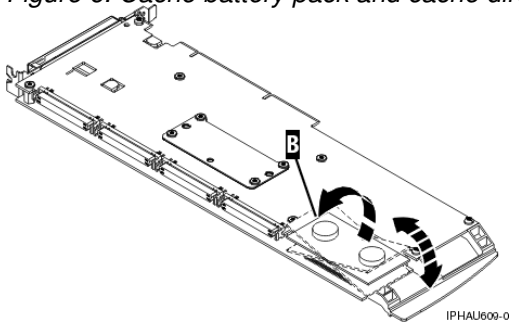
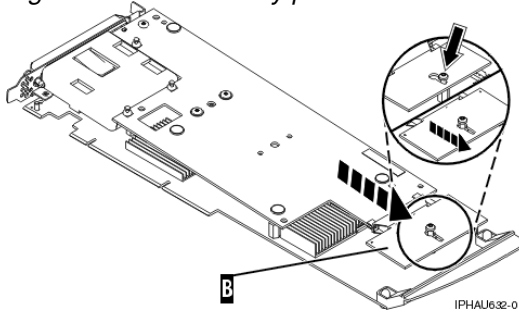


Figure 7. Cache battery pack and cache directory card for type 571E



10. Locate the cache directory card **B**. To locate the cache directory card for your card type, refer to the graphics listed in step 9. In the graphics the **B** designation is always the cache directory card.
11. Loosen the retaining screw located on the cache directory card one full turn. *Do not* remove the retaining screw.
12. Unseat the cache directory card from the connector. To unseat and remove the cache directory card, wiggle the card back and forth toward the plastic card handle, then lift the cache directory card up and off the retaining screw.
13. Install the replacement cache directory card. To install the replacement cache directory card, place it down over the retaining screw, then slide it away from the plastic card handle to fully seat it in the connector.
14. Tighten the retaining screw. **This ends the procedure.**

**Parent topic:** [Removing and replacing parts on type 2748, 2757, 2763, 2778, 2780, 2782, 4758, 4764, 5703, 5708, 5709, 571B, 571E, 571F, 573D, 574F, 575B](#)

## Disabling the cryptographic coprocessor on a type 4758 card

**Note:** For security, use the following procedure when replacing the cryptographic coprocessor.

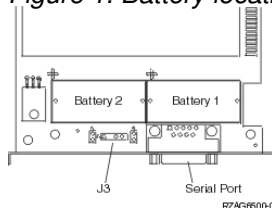
Use this procedure to properly and permanently disable the Type 4758 PCI cryptographic coprocessor card.

**Attention:** During disablement, the contents of the coprocessor's protected memory will be set to zeros. The cryptographic master key and other data stored in the protected memory will be lost.

**CAUTION:**The battery is a lithium ion battery. To avoid possible explosion, do not burn. Exchange only with the approved part. Recycle or discard the battery as instructed by local regulations. (C007a)

1. Remove the cryptographic coprocessor card using the Cards (concurrent) remove and replace procedure for the system unit or tower in which the card is located. See [Removing and replacing parts](#), choose the correct model, and then the Cards (concurrent) procedure.
2. Locate the lithium batteries, which are located in adjacent holders, with the battery 2 above the J3 connector. Refer to the following illustration.

Figure 1. Battery locations on the PCI cryptographic coprocessor



**Note:** The 4758-023 card contains four batteries, even though only two batteries are shown in the preceding figure. Battery 3 is directly above battery 1, and battery 4 is directly above battery 2.

**Attention:** The loss of battery power erases data stored in the card's protected memory and renders the card useless.

3. Remove the battery from each battery holder in sequential order. If this is a 4758-023 card, remove the batteries in the following order: battery 1, battery 2, battery 3, battery 4. For all other cards, remove battery 1 and then battery 2.
4. The PCI cryptographic coprocessor card has been disabled. You can now install the new card. This ends the procedure.

**Parent topic:** [Removing and replacing parts on type 2748, 2757, 2763, 2778, 2780, 2782, 4758, 4764, 5703, 5708, 5709, 571B, 571E, 571F, 573D, 574F, 575B](#)

## Disabling the cryptographic coprocessor on a type 4764 card

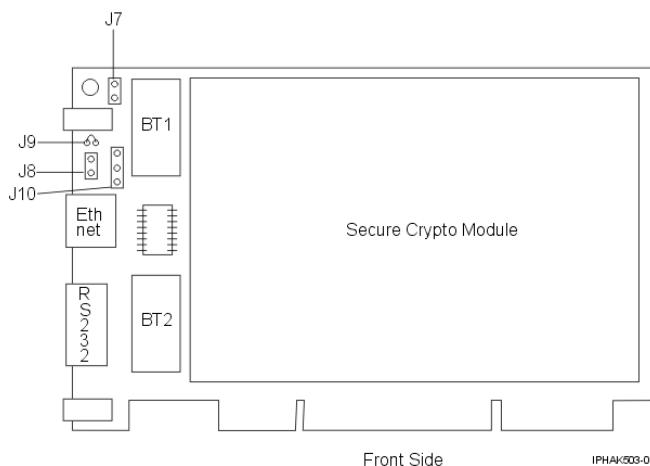
**Attention:** For security, use the following procedure when replacing the cryptographic coprocessor.

Use this procedure to properly and permanently disable the Type 4764 PCI cryptographic coprocessor card. During disablement, the contents of the coprocessor's protected memory will be set to zeroes. The cryptographic master key and other data stored in the protected memory will be lost.

**CAUTION:**The battery is a lithium ion battery. To avoid possible explosion, do not burn. Exchange only with the approved part. Recycle or discard the battery as instructed by local regulations. (C007a)

1. Remove the cryptographic coprocessor card using the Cards (concurrent) remove and replace procedure for the system unit or tower in which the card is located. See [Removing and replacing parts](#), choose the correct model, and then the Cards (concurrent) procedure.
2. Find the location of the lithium batteries. They are located in adjacent holders, with the battery 2 above the J10 connector. Refer to the illustration below.

Figure 1. Battery locations on the PCI cryptographic coprocessor



**Attention:** The loss of battery power erases data stored in the card's protected memory and renders the card useless.

3. Remove battery 1 and then battery 2.
4. The PCI cryptographic coprocessor card has been disabled. You can now install the new card. This ends the procedure.

**Parent topic:** [Removing and replacing parts on type 2748, 2757, 2763, 2778, 2780, 2782, 4758, 4764, 5703, 5708, 5709, 571B, 571E, 571F, 573D, 574F, 575B](#)

## Tape cartridge, manual removal

Use this information to remove a tape cartridge from a tape unit.

- **4685 - tape cartridge**

Use this procedure to remove a tape cartridge manually from a 4685 tape unit.

- **6335 - 1/4 inch tape cartridge**

- **6383, 6384, 6385, 6386, 6387 - tape cartridge**

Use this procedure to manually remove a tape cartridge from a 6383, 6384, 6385, 6386, or 6387 tape unit. You may need this procedure if a power failure or tape unit failure prevent the tape cartridge from ejecting.

**Parent topic:** [Removing and replacing parts](#)

---

### 4685 - tape cartridge

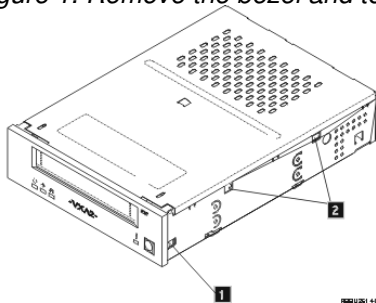
Use this procedure to remove a tape cartridge manually from a 4685 tape unit.

This procedure may be required if a defective tape cartridge or tape unit has caused the cartridge ejection function to fail, or if the data on the tape cartridge is either critical or sensitive and the customer cannot afford its loss.

**Attention:** This procedure is very delicate and may damage or destroy the tape cartridge. Use this procedure only when you are not able to unload the cartridge by pressing and holding the unload button.

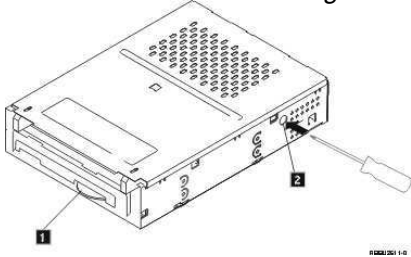
1. Remove the 4685 tape drive tray from the frame.
2. Remove the 4685 tape drive from the tray.
3. Remove the front bezel (the bezel snaps on) by doing the following:
  - a. Use a small screwdriver to press the bezel tabs (see 1 in [Figure 1](#)) on each side of the drive.
  - b. Rotate the bottom of the bezel toward the front to release the bezel attachments on the top of the drive.
  - c. Lift the bezel off the top locating tabs.
  - d. Remove the bezel from the unit.

*Figure 1. Remove the bezel and top cover from the tape drive*



4. Remove the top lid of the drive mechanism by doing the following:
  - a. Use a small screwdriver to press the top tabs (see 2 in [Figure 1](#)) on each side of the drive.
  - b. Slide the cover approximately 5mm to the rear, and then lift the cover off.
5. Locate the large thumbwheel below the right side of the data cartridge.
6. Gently rotate the thumbwheel (see 1 in [Figure 2](#)) counterclockwise to remove slack from the tape by winding the media onto the take-up reel.

Figure 2. Rotate the thumbwheel counterclockwise to remove slack from the tape and turn the load motor to release the cartridge



7. Insert a Phillips screwdriver in the load motor access hole (see 2 in [Figure 2](#)). Rotate the load motor clockwise to unwind the tape path. Unwind the mechanism until tape slack appears.
8. After tape slack appears, gently rotate the thumbwheel again to remove the slack from the tape by winding the media onto the take-up reel.
9. Repeat steps 7 and 8 until all of the tape media is wound onto the cartridge take-up wheel.
10. When the tape is completely rewound into the cartridge, turn the load motor clockwise until the tape cartridge is lifted out of the drive mechanism and ejected.
11. Remove the tape cartridge, install the bezel, and attach the top cover.
12. Reassemble the drive in reverse order. This ends the procedure.

Parent topic: [Tape cartridge, manual removal](#)

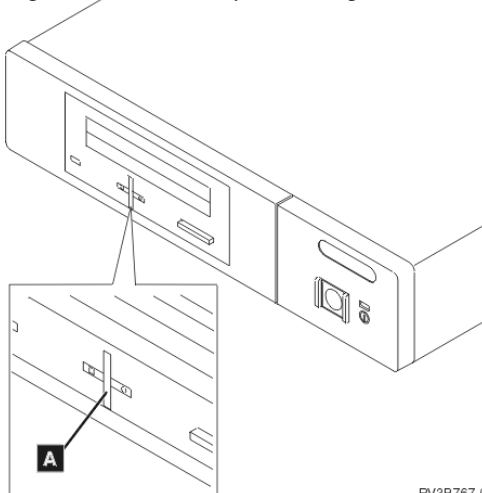
## 6335 - 1/4 inch tape cartridge

Use this procedure to remove a tape cartridge manually from an internal 1/4 inch tape unit. This procedure may be required if a defective tape cartridge or tape unit has caused the cartridge ejection function to fail, or if the data on the tape cartridge is either critical or sensitive and the customer cannot afford its loss.

**Attention:** This procedure is very delicate, and if not performed correctly, can damage or destroy the tape cartridge. Use this procedure only when you have attempted the other options for removing the tape cartridge.

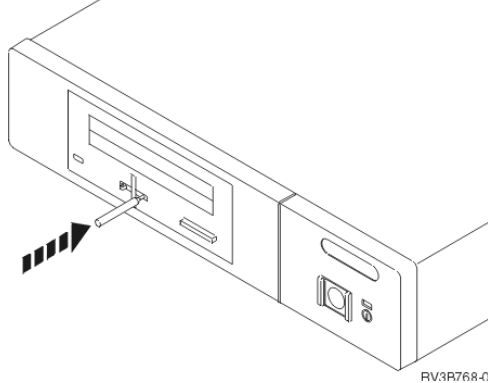
1. Power off the tape unit.
2. Carefully lift and turn the manual tape cartridge unload lid A.

Figure 1. Manual tape cartridge unload lid



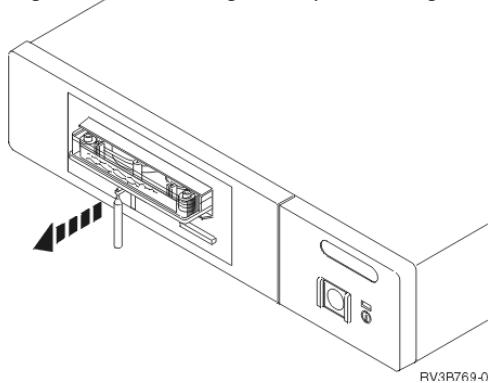
3. Insert a solid metal rod (such as a Bristol wrench) into the manual tape cartridge unload hole, and push in until it stops and the arm appears.

Figure 2. Metal rod being inserted into the manual tape cartridge unload hole



4. Pull the arm out until it stops. Insert the solid metal rod into the hole of the arm, and pull out until the tape cartridge comes out.

Figure 3. Removing the tape cartridge



5. Remove the tape cartridge.
6. Push the arm back in until it stops, turn the manual tape cartridge lid back to the starting position and push it back in place. This ends the procedure.

Parent topic: [Tape cartridge, manual removal](#)

---

## 6383, 6384, 6385, 6386, 6387 - tape cartridge

Use this procedure to manually remove a tape cartridge from a 6383, 6384, 6385, 6386, or 6387 tape unit. You may need this procedure if a power failure or tape unit failure prevent the tape cartridge from ejecting.

**Attention:** This procedure is very delicate and may damage or destroy the tape cartridge. Use this procedure only when you have tried the other options for removing the tape cartridge.

1. Open the tape unit door and check the location of the bridge.
2. If the bridge is engaged to the cartridge, go to the Locked position procedure.
3. If the bridge is moved away from the cartridge, go to the Standby position procedure

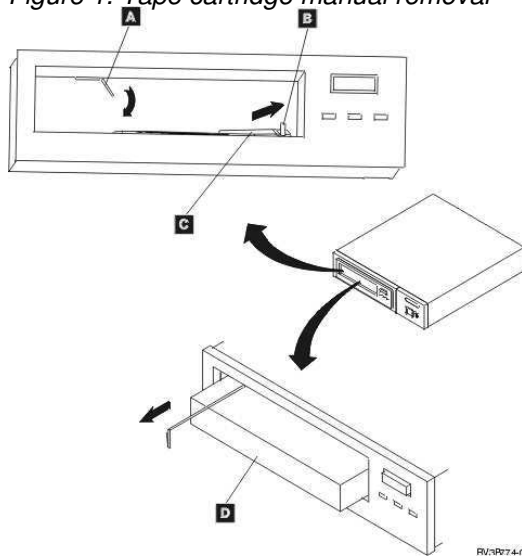
**Parent topic:** [Tape cartridge, manual removal](#)**Locked position**

1. Power off the tape unit.
2. Open the tape unit door.
3. Locate the metal axle B inside the tape unit. Look toward the lower-right corner.
4. Insert a pointed object (such as a pen or screwdriver) into the tape unit and push the axle inward.
5. Push the bridge C to the right. The tape unit is now in standby position.
6. Continue with the Standby position procedure.

**Standby position**

1. Power off the tape unit.
2. Open the tape unit door.
3. Locate the hook shaped metal rod A inside the tape unit in the upper-left corner.
4. Insert a pointed object (such as a pen or screwdriver) into the tape unit and push the metal rod downward.
5. Pull the metal rod forward until the cartridge ejects. The cartridge D is pushed out of the tape unit door and can be removed.

Figure 1. Tape cartridge manual removal



This ends the procedure.

---

## Optical media (CD-ROM, DVD-ROM, and DVD-RAM) - manual removal

Use this procedure to manually remove optical media (CD-ROM, DVD-ROM, or DVD-RAM) from the disc tray.

**Note:** If the device power is lost due to a power failure or other reason while the disc tray is closed in the device and it is necessary to open the disc tray, the eject pin (see the following specifications) can be inserted into the emergency eject hole on the front bezel, causing the disc tray to open, allowing you to remove the media.

**Attention:** Damage to a DVD-RAM device can result if the manual ejection function is used while the device is powered on. Remove the device before manually ejecting the media.

1. Insert the eject pin that is approximately 1.5 mm in diameter and at least 60 mm (DVD-RAM) or 35 mm (CD-ROM) in length into the manual eject hole and push firmly. The front edge of the tray will push open approximately 1/4 of an inch. Push until the disc tray opens far enough to remove the media.

**Note:** If an eject pin is not easily obtainable, you can use a long paper clip.

2. Grasp the tray and slowly pull it out far enough to remove the media. This ends the procedure.

**Parent topic:** [Removing and replacing parts](#)

---

## Problem determination procedure for AIX or Linux servers or partitions

This procedure helps to produce or retrieve a service request number (SRN) if the customer or a previous procedure did not provide one.

If your server is running AIX or Linux, use one of the following procedures to test the server or partition resources to help you determine where a problem might exist.

If you are servicing a server running the AIX operating system, go to [MAP 0020: Problem determination procedure](#).

If you are servicing a server running the Linux operating system, go to the [Linux problem isolation procedure](#).

**Parent topic:** [Detecting problems](#)

---

## MAP 0020: Problem determination procedure

Use this MAP to get a service request number (SRN) if the customer or a previous MAP provided none.

### Purpose of this MAP

Use this MAP to get a service request number (SRN) if the customer or a previous MAP provided none. If you are unable to power the system on, refer to the [Power isolation procedure](#).

- Step 0020-1

Visually check the server for obvious problems such as unplugged power cables or external devices that are powered off.

Did you find an obvious problem?

NO

Go to [Step 0020-2](#).

YES

Fix the problem, then go to [MAP 0410: Repair Checkout](#).

- Step 0020-2



Are the AIX online diagnostics installed?

**Note:** If AIX is not installed on the server or partition, answer no to the above question.

NO

If the operating system is running, perform its shutdown procedure. Get help if needed. Go to [Step 0020-4](#).

YES

Go to [Step 0020-3](#).

- Step 0020-3

**Note:** When possible, run online diagnostics in service mode. Online diagnostics perform additional functions compared to standalone diagnostics.

Run online diagnostics in concurrent mode when the customer does not let you power-off the system unit. To run online diagnostics in service mode, go to [substep 5](#). If the system unit is already running in the service mode and you want to run online diagnostics, proceed to the question at the bottom of this MAP step. Otherwise, continue with [1](#) through [4](#) in the following procedure.

1. Log in with root authority or use CE login. If necessary, ask the customer for the password.
2. Enter the diag -a command to check for missing resources.
  - a. If you see a command line prompt, proceed to [substep 3](#) below.
  - b. If the DIAGNOSTIC SELECTION menu is displayed, with the letter M shown next to any resource, select that resource, then press Commit (F7 key). Follow any instructions displayed. If you are prompted with a message `Do you want to review the previously displayed error` select Yes and press Enter. If an SRN displays, record it, and go to [Step 0020-15](#). If there is no SRN, go to [substep 3](#) below.
  - c. If MISSING RESOURCE menu is displayed, follow any instructions displayed. If you are prompted with a message `Do you want to review the previously displayed error` select Yes and press Enter. If an SRN displays, record it, and go to [Step 0020-15](#). If there is no SRN, go to [substep 3](#) below.
3. Enter the diag command.
4. Go to [Step 0020-5](#).
5. If the operating system is running, perform its shut down procedure (get help if needed).
6. Turn off the system unit power and wait 45 seconds before proceeding.
7. Turn on the system unit power.
8. Load the online diagnostics in service mode.
9. Wait until the Diagnostic Operating Instructions display or the system appears to have stopped.

**Are the Diagnostic Operating Instructions displayed?**

NO

Go to [Step 0020-16](#).

YES

Go to [Step 0020-5](#).

- Step 0020-4

**Note:** If you are working on a partition, do not remove the power as directed in the following procedure. Only remove the power if you are working on a server that does not have multiple partitions.

1. If the server does not have multiple partitions, disconnect the power from the server, wait 45 seconds, then reconnect the power.

2. If the server supports slow boot (See [Performing a slow boot](#)) set the server to perform a slow boot for the next boot that is performed. If the system does not support slow boot, do a normal boot in the next step.
3. Refer to [Loading the AIX online and standalone diagnostics](#) to load the standalone diagnostics. Before continuing to the next step, ensure that the server power is turned on, or if you are working on a partition, the partition is started. The server or partition should be booting the standalone diagnostics from a CD-ROM or a network server.
4. Wait until the Diagnostic Operating Instructions display or the server boot appears to have stopped.

**Are the Diagnostic Operating Instructions displayed?**

NO

Go to [Step 0020-16](#).

YES

Go to [Step 0020-5](#).

- Step 0020-5

**Are the Diagnostic Operating Instructions displayed (screen number 801001) with no obvious problem (for example, blurred or distorted)?**

NO

For display problems, go to [Step 0020-12](#).

YES

To continue with diagnostics, go to [Step 0020-6](#).

- Step 0020-6

Press the Enter key.

**Is the FUNCTION SELECTION menu displayed (screen number 801002)?**

NO

Go to [Step 0020-13](#).

YES

Go to [Step 0020-7](#).

- Step 0020-7
  1. Select the ADVANCED DIAGNOSTICS ROUTINES option.

**Notes:**

- a. If the terminal type is not defined, do so now. You cannot proceed until this is complete.
  - b. If you have SRNs from a Previous Diagnostics Results screen, process these Previous Diagnostics Results SRNs prior to processing any SRNs you may have received from an SRN reporting screen.
2. If the DIAGNOSTIC MODE SELECTION menu (screen number 801003) displays, select the PROBLEM DETERMINATION option.
  3. Find your system response in the following table. Follow the instructions in the Action column.

| System Response                                                                    | Action                                                                                                                                                                                                                                                                                                                                                                  |
|------------------------------------------------------------------------------------|-------------------------------------------------------------------------------------------------------------------------------------------------------------------------------------------------------------------------------------------------------------------------------------------------------------------------------------------------------------------------|
| Previous Diagnostic Results. Do you want to review the previously displayed error? | <p>You have a pending item in the error log for which there is no corresponding <a href="#">Log Repair Action</a>. To see this error, select YES at the prompt.</p> <p>Information from the error log is displayed in order of last event first. Record the error code, the FRU names and the location code of the FRUs.</p> <p>Go to <a href="#">Step 0020-15</a>.</p> |
| The RESOURCE SELECTION menu or the ADVANCED DIAGNOSTIC SELECTION                   | Go to <a href="#">Step 0020-8</a> .                                                                                                                                                                                                                                                                                                                                     |

|                                                                                                                                    |                                                                                                                                                                                                                                                                                                                                                                                                                                                                                                                                                                                                                                                                                                                                                                                                                                                                                                                                                                                                                                                                                                                                           |
|------------------------------------------------------------------------------------------------------------------------------------|-------------------------------------------------------------------------------------------------------------------------------------------------------------------------------------------------------------------------------------------------------------------------------------------------------------------------------------------------------------------------------------------------------------------------------------------------------------------------------------------------------------------------------------------------------------------------------------------------------------------------------------------------------------------------------------------------------------------------------------------------------------------------------------------------------------------------------------------------------------------------------------------------------------------------------------------------------------------------------------------------------------------------------------------------------------------------------------------------------------------------------------------|
| menu is displayed (screen number 801006).                                                                                          |                                                                                                                                                                                                                                                                                                                                                                                                                                                                                                                                                                                                                                                                                                                                                                                                                                                                                                                                                                                                                                                                                                                                           |
| The system halted while testing a resource.                                                                                        | Record SRN 110-xxxx, where xxxx is the first four digits of the menu number displayed in the upper-right corner of the diagnostic menu. Go to <a href="#">Step 0020-15</a> .                                                                                                                                                                                                                                                                                                                                                                                                                                                                                                                                                                                                                                                                                                                                                                                                                                                                                                                                                              |
| The MISSING RESOURCE menu is displayed or the letter M is displayed alongside a resource in the resource list.                     | <p>If the MISSING RESOURCE menu is displayed, follow the displayed instructions until either the ADVANCED DIAGNOSTIC SELECTION menu or an SRN is displayed. If an M is displayed in front of a resource (indicating that it is missing) select that resource then choose the Commit (F7 key).</p> <p><b>Notes:</b></p> <ol style="list-style-type: none"> <li>1. Run any supplemental media that may have been supplied with the adapter or device, and then return to substep 1 of <a href="#">Step 0020-7</a>.</li> <li>2. If the SCSI enclosure services device appears on the missing resource list along with the other resources, select it first.</li> <li>3. ISA adapters cannot be detected by the system. The ISA adapter configuration service aid in standalone diagnostics allows the identification and configuration of ISA adapters.</li> </ol> <p>If the ADVANCED DIAGNOSTIC SELECTION menu is displayed, go to <a href="#">Step 0020-11</a>.</p> <p>If an 8-digit error code is displayed, go to <a href="#">Reference codes</a>.</p> <p>If an SRN is displayed, record it, and go to <a href="#">Step 0020-15</a>.</p> |
| The message <code>The system will now continue the boot process</code> is displayed continuously on the system unit's console.     | Go to <a href="#">Step 0020-4</a> .                                                                                                                                                                                                                                                                                                                                                                                                                                                                                                                                                                                                                                                                                                                                                                                                                                                                                                                                                                                                                                                                                                       |
| The message <code>Processing supplemental diagnostic diskette media</code> is displayed continuously on the system unit's console. | Call your service support structure.                                                                                                                                                                                                                                                                                                                                                                                                                                                                                                                                                                                                                                                                                                                                                                                                                                                                                                                                                                                                                                                                                                      |
| The diagnostics begin testing a resource.                                                                                          | <p>Follow the displayed instructions.</p> <p>If the No Trouble Found screen is displayed, press Enter.</p> <p>If another resource is tested, repeat this step.</p> <p>If the ADVANCED DIAGNOSTIC SELECTION menu is displayed, go to <a href="#">Step 0020-11</a>.</p> <p>If an SRN is displayed, record it, and go to <a href="#">Step 0020-15</a>.</p> <p>If an 8-digit error code is displayed, go to <a href="#">Reference codes</a>.</p>                                                                                                                                                                                                                                                                                                                                                                                                                                                                                                                                                                                                                                                                                              |
| The system did not respond to selecting the advanced diagnostics option.                                                           | Go to <a href="#">Step 0020-13</a> .                                                                                                                                                                                                                                                                                                                                                                                                                                                                                                                                                                                                                                                                                                                                                                                                                                                                                                                                                                                                                                                                                                      |
| A system unit with a beeper did not beep while booting.                                                                            | Record SRN 111-947 and then go to <a href="#">Step 0020-15</a>                                                                                                                                                                                                                                                                                                                                                                                                                                                                                                                                                                                                                                                                                                                                                                                                                                                                                                                                                                                                                                                                            |

|                                                                                                                    |                                                                                                                                                                                                                             |
|--------------------------------------------------------------------------------------------------------------------|-----------------------------------------------------------------------------------------------------------------------------------------------------------------------------------------------------------------------------|
| The system unit emits a continuous sound from the beeper.                                                          | Record SRN 111-947 and then go to <a href="#">Step 0020-15</a> .                                                                                                                                                            |
| An SRN or an eight-digit error code is displayed.                                                                  | Record the error code, the FRU names, and the location code for the FRUs. If a SRN is displayed, go to <a href="#">Step 0020-15</a> .<br><br>If an 8-digit error code is displayed, go to <a href="#">Reference codes</a> . |
| The system stopped with a 3-digit or 4-digit code displayed in the operator panel display.                         | Record SRN 101-xxx (where xxx is the rightmost three digits of the displayed code). Go to <a href="#">Step 0020-15</a> .                                                                                                    |
| An 888 message is displayed in the operator panel display.<br><br><b>Note:</b> The 888 may or may not be flashing. | Go to <a href="#">Isolation MAP 0070: 888 Sequence in operator panel display</a> .                                                                                                                                          |

- Step 0020-8

On the DIAGNOSTIC SELECTION or ADVANCED DIAGNOSTIC SELECTION menu, look through the list of resources to make sure that all adapters and SCSI devices are listed including any new resources.

**Notes:**

1. Resources attached to serial and parallel ports may not appear in the resource list.
2. If running diagnostics in a partition within a partitioned system, resources assigned to other partitions will not be displayed on the resource list.

**Did you find the all the adapters or devices on the list?**

NO

Go to [Step 0020-9](#).

YES

Go to [Step 0020-11](#).

- Step 0020-9

**Is the new device or adapter an exact replacement for a previous one installed at same location?**

NO

Go to [Step 0020-10](#).

YES

The replacement device or adapter may be defective. If possible, try installing it in an alternate location if one is available; if it works in that location, then suspect that the location where it failed to appear has a defective slot; schedule time to replace the hardware that supports that slot. If it does not work in alternate location, suspect a bad replacement adapter or device. If you are still unable to detect the device or adapter, contact your service support structure.

- Step 0020-10

**Is the operating system software to support this new adapter or device installed?**

NO

Load the operating system software.

YES

The replacement device or adapter may be defective. If possible, try installing it in an alternate location if one is available; if it works in that location, then suspect that the location where it failed to appear has a defective slot; schedule time to replace the hardware that

supports that slot. If it does not work in alternate location, suspect a bad replacement adapter or device. If you are still unable to detect the device or adapter, contact your service support structure.

- Step 0020-11

Select and run the diagnostic test problem determination or system verification on one of the following:

- ◆ The resources with which the customer is having problems. If the resource is not shown on the DIAGNOSTIC SELECTION menu, then run diagnostics on its parent (the adapter or controller to which the resource is attached).
- ◆ The resources you suspect are causing a problem.
- ◆ All resources.

**Note:** When choosing All Resources, interactive tests are not done. If no problem is found running All Resources you should choose each of the individual resources on the selection menu to run diagnostics tests on to do the interactive tests

Find the response in the following table or follow the directions on the test results screen.

| Diagnostic Response                                                                                                                   | Action                                                                                                                                                                                                                                                                                                                                                                  |
|---------------------------------------------------------------------------------------------------------------------------------------|-------------------------------------------------------------------------------------------------------------------------------------------------------------------------------------------------------------------------------------------------------------------------------------------------------------------------------------------------------------------------|
| An SRN or an eight-digit error code is displayed on the screen.                                                                       | Record the error code, the FRU names, and the location code for the FRUs. If an SRN is displayed, go to <a href="#">Step 0020-15</a> . If an 8-digit error code is displayed, go to the ESCALA Power5 Hardware Information, and perform a search on the error code to obtain the name and location of the failing FRU. Perform the listed action.                       |
| The TESTING COMPLETE menu and the No trouble was found message are displayed, and you have not tested all of the resources.           | Press Enter and continue testing other resources.                                                                                                                                                                                                                                                                                                                       |
| The TESTING COMPLETE menu and the No trouble was found message are displayed, and you have tested all of the resources.               | Go to <a href="#">Step 0020-14</a> .<br><br><b>Note:</b> If you have not run the sysplanar test, do so before going to <a href="#">Step 0020-14</a> .                                                                                                                                                                                                                   |
| The system halted while testing a resource.                                                                                           | Record SRN 110-xxxx, where xxxx is the first three or four digits of the menu number displayed in the upper-right corner of the diagnostic menu screen.<br><br>Go to <a href="#">Step 0020-15</a> .                                                                                                                                                                     |
| When running the Online Diagnostics, an installed device does not appear in the test list.                                            | Ensure that the diagnostic support for the device was installed. The display configuration service aid can be used to determine whether diagnostic support is installed for the device.<br><br>Record SRN 110-101. Go to <a href="#">Step 0020-15</a> .<br><br><b>Note:</b> Supplemental diskettes may be required if service aids are run from standalone diagnostics. |
| The ARTIC960 Quad T1/E1 adapter diagnostics display a message indicating that the interface board (PMC) is either not installed or is | Install a PMC board if not already installed.<br><br>When running online diagnostics on any of the ARTIC960 family of adapters and the message indicates that the PMC (daughter board) is not installed, but it is installed, do the following:                                                                                                                         |

|                                         |                                                                                                                                                                                                                   |
|-----------------------------------------|-------------------------------------------------------------------------------------------------------------------------------------------------------------------------------------------------------------------|
| malfunctioning.                         | <ul style="list-style-type: none"> <li>◆ Reseat the PMC board, then run diagnostics.</li> <li>◆ If the response is the same, replace the PMC and then go to <a href="#">MAP 0410: Repair Checkout</a>.</li> </ul> |
| The symptom was not found in the table. | Go back to the <a href="#">Start of call procedure</a> .                                                                                                                                                          |

- Step 0020-12

The following step analyzes a console display problem.

Find your type of console display in the following table. Follow the instructions given in the Action column.

| Type of Console Display           | Action                                                                                                                                                                                                                                                                                                                                                                                                                                                                                                                                      |
|-----------------------------------|---------------------------------------------------------------------------------------------------------------------------------------------------------------------------------------------------------------------------------------------------------------------------------------------------------------------------------------------------------------------------------------------------------------------------------------------------------------------------------------------------------------------------------------------|
| TTY-type terminal                 | <p>Be sure the TTY terminal attributes are set correctly. See "Running the Diagnostic Programs from a TTY Terminal" in <a href="#">Using Standalone and Online Diagnostics</a>.</p> <p>If you did not find a problem with the attributes, go to the documentation for this type of TTY terminal, and continue problem determination. If you do not find the problem, record SRN 111-259, then go the <a href="#">Step 0020-15</a>.</p>                                                                                                      |
| Graphics display                  | Go to the documentation for this type of graphics display, and continue problem determination. If you do not find the problem, record SRN 111-82c, then go to <a href="#">Step 0020-15</a> .                                                                                                                                                                                                                                                                                                                                                |
| HMC (Hardware Management Console) | Go to <a href="#">HMC isolation procedures</a> . If HMC tests find no problem, there may be a problem with the communication between the HMC and the managed system. If the HMC communicates with the managed system through a network interface, verify whether the network interface is functional. If the HMC communicates with the managed system through the HMC interface, check the cable between the HMC and the managed system. If it is not causing the problem, suspect a configuration problem of the HMC communications setup. |

- Step 0020-13

There is a problem with the keyboard.

Find the type of keyboard you are using in the following table. Follow the instructions given in the Action column.

| Keyboard Type                                                                                                         | Action                                                                                                                                                                                            |
|-----------------------------------------------------------------------------------------------------------------------|---------------------------------------------------------------------------------------------------------------------------------------------------------------------------------------------------|
| Type 101 keyboard (U.S.). Identify by the size of the Enter key. The Enter key is in only one horizontal row of keys. | Record SRN 111-736, then go to <a href="#">Step 0020-15</a> .                                                                                                                                     |
| Type 102 keyboard (W.T.). Identify by the size of the Enter key. The Enter key extends into two horizontal rows.      | Record SRN 111-922; then go to <a href="#">Step 0020-15</a> .                                                                                                                                     |
| Kanji-type keyboard. (Identify by the Japanese characters.)                                                           | Record SRN 111-923; then go to <a href="#">Step 0020-15</a> .                                                                                                                                     |
| TTY terminal keyboard                                                                                                 | Go to the documentation for this type of TTY terminal and continue problem determination.                                                                                                         |
| HMC (Hardware Management Console)                                                                                     | Go to <a href="#">HMC isolation procedures</a> . If HMC tests find no problem, there may be a problem with the communication between the HMC and the managed system. If the HMC communicates with |

|  |                                                                                                                                                                                                                                                                                                                                           |
|--|-------------------------------------------------------------------------------------------------------------------------------------------------------------------------------------------------------------------------------------------------------------------------------------------------------------------------------------------|
|  | the managed system through a network interface, verify whether the network interface is functional. If the HMC communicates with the managed system through the HMC interface, check the cable between the HMC and the managed system. If it is not causing the problem, suspect a configuration problem of the HMC communications setup. |
|--|-------------------------------------------------------------------------------------------------------------------------------------------------------------------------------------------------------------------------------------------------------------------------------------------------------------------------------------------|

- Step 0020-14

The diagnostics did not detect a problem.

If the problem is related to either the system unit or the I/O expansion box, refer to the service documentation for that unit.

If the problem is related to an external resource, use the problem determination procedures, if available, for that resource.

If a problem occurs when running online diagnostics but not when running the stand-alone diagnostics, suspect a software problem.

Check for the presence of supplemental diagnostic material, such as diskettes or documentation.

This is possibly a problem with software or intermittent hardware. If you think that you have an intermittent hardware problem, go to [MAP 0040: Intermittent problem isolation](#).

- Step 0020-15

Take the following actions:

1. Handle multiple SRNs and error codes in the following order:
  - a. 8-Digit Error Codes.
  - b. SRNs with a source code other than F or G.
  - c. SRNs with a source code of F. Run online diagnostics in advanced and problem determination mode to obtain maximum isolation.
  - d. SRNs with a source code of G.

**Note:** The priority for multiple SRNs with a source of G is determined by the time stamp of the failure. Follow the action for the SRN with the earliest time stamp first.

- e. Device SRNs and error codes (5-digit SRNs).  
If a group has multiple SRNs, it does not matter which SRN is handled first.
2. Find the SRN in the [List of service request numbers](#).

**Note:** If the SRN is not listed, look for it in the following:

- ◇ Any supplemental service manual for the device
- ◇ The diagnostic problem report screen for additional information
- ◇ The "Service Hints" service aid in [Using standalone and online diagnostics](#)
- ◇ The [CEREADME file](#) (by using the Service Hints service aid)

3. Perform the action listed.
4. If you replace a part, go to [MAP 0410: Repair checkout](#).

- Step 0020-16

Refer to [AIX IPL progress codes](#) for definitions of configuration program indicators. They are normally 0xxx.

**Is a configuration program indicator displayed?**

NO

Go to the [Problems with loading and starting the operating system \(AIX and Linux\)](#)

YES

Record SRN 101-xxxx (where xxxx is the rightmost three or four digits or characters of the configuration program indicator). Go to [Step 0020-17](#).

- Step 0020-17

**Is a physical location code or an AIX location code displayed on the operator panel display?**

NO

Go to [Step 0020-15](#).

YES

Record the location code, then go to [Step 0020-15](#).

## MAP 0040: Intermittent Problem Isolation

This MAP provides a structured way of analyzing intermittent problems.

### Purpose of This MAP

This MAP provides a structured way of analyzing intermittent problems. It consists of two tables: Hardware Symptoms and Software Symptoms.

Because software or hardware can cause intermittent problems, consider all symptoms relevant to your problem.

### How to Use This MAP

This MAP contains information about causes of intermittent symptoms. In the following tables, find your symptoms, and read the list of things to check.

When you exchange a FRU, go to [MAP 0410: Repair Checkout](#) to check out the system.

### Hardware Symptoms

**Note:** This table spans several pages.

| Symptom of Hardware Problem              | Things to Check For                                                                                                                                                                                                                                                                                                                                                                                                                           |
|------------------------------------------|-----------------------------------------------------------------------------------------------------------------------------------------------------------------------------------------------------------------------------------------------------------------------------------------------------------------------------------------------------------------------------------------------------------------------------------------------|
| Any hardware log entry in the error log. | <p>Use the Hardware Error Report service aid to view the error log and check for:</p> <ul style="list-style-type: none"> <li>• Multiple errors on devices attached to the same SCSI bus.</li> <li>• Multiple errors on devices attached to the same async adapter.</li> <li>• Multiple errors on internally installed devices only.</li> </ul> <p>Contact your service support structure for assistance with error report interpretation.</p> |
| Hardware-caused system crashes           | <ul style="list-style-type: none"> <li>• The connections on the CPU planar or CPU card</li> <li>• Memory modules for correct connections</li> <li>• Connections to the system planar.</li> </ul>                                                                                                                                                                                                                                              |



Service provider information

|                                                                   |                                                                                                                                                                                                                                                                                                                                                                                                                                                                                                                                                                                                                                                                                                                                                                                                                                                                                                         |
|-------------------------------------------------------------------|---------------------------------------------------------------------------------------------------------------------------------------------------------------------------------------------------------------------------------------------------------------------------------------------------------------------------------------------------------------------------------------------------------------------------------------------------------------------------------------------------------------------------------------------------------------------------------------------------------------------------------------------------------------------------------------------------------------------------------------------------------------------------------------------------------------------------------------------------------------------------------------------------------|
|                                                                   | <ul style="list-style-type: none"> <li>• Cooling fans operational</li> <li>• The environment for a too-high or too-low operating temperature.</li> <li>• Vibration: proximity to heavy equipment.</li> </ul>                                                                                                                                                                                                                                                                                                                                                                                                                                                                                                                                                                                                                                                                                            |
| System unit powers off a few seconds after powering On.           | <ul style="list-style-type: none"> <li>• Fan speed. Some fans contain a speed-sensing circuit. If one of these fans is slow, the power supply powers the system unit off.</li> <li>• Correct voltage at the outlet into which the system unit is plugged.</li> <li>• Loose power cables and fan connectors, both internal and external.</li> </ul>                                                                                                                                                                                                                                                                                                                                                                                                                                                                                                                                                      |
| System unit powers off after running for more than a few seconds. | <ul style="list-style-type: none"> <li>• Excessive temperature in the power supply area.</li> <li>• Loose cable connectors on the power distribution cables.</li> <li>• Fans turning at full speed after the system power has been on for more than a few seconds.</li> </ul>                                                                                                                                                                                                                                                                                                                                                                                                                                                                                                                                                                                                                           |
| Only internally installed devices are failing.                    | <p>Check the following items that are common to more than one device:</p> <ul style="list-style-type: none"> <li>• Ground connections on all of the disk drives and other types of drives installed.</li> <li>• Loose connections on the power cables to the planars, drives, fans, and battery.</li> <li>• System unit cooling. Is the input air temperature within limits? Are all the fans running at full speed? Are any of the vent areas blocked?</li> <li>• Signal cables to the diskette drives, and the power supply.</li> <li>• SCSI device signal cables for loose connectors and terminators.</li> <li>• Loose SCSI device address jumpers.</li> <li>• Possible contamination of any device that has a cleaning procedure. See the operator guide for cleaning instructions.</li> <li>• Excessive static electricity.</li> <li>• Correct voltage at the system unit power outlet</li> </ul> |
| Only externally attached devices are failing.                     | <p>Check the following items that are common to more than one device.</p> <ul style="list-style-type: none"> <li>• Check the SCSI signal cables to the devices for loose connectors and terminators.</li> <li>• Check devices that use jumpers to set the SCSI address for loose jumpers.</li> <li>• Check any device that has a cleaning procedure for contamination. See the operator guide for cleaning instructions.</li> <li>• Check for excessive static electricity.</li> <li>• Check the outlet that the device is plugged into for correct voltage.</li> <li>• Check the error log for entries for the adapter driving the failing devices.</li> <li>• Check the temperature of the devices. Are the cooling vents blocked? Are the fans running?</li> <li>• Check for other devices near the failing device that may be radiating noise (displays, printers, and so on).</li> </ul>           |

## Software Symptoms

| Symptom of Software Problem                     | Things to Check For                                          |
|-------------------------------------------------|--------------------------------------------------------------|
| Any symptom you suspect is related to software. | Use the software documentation to analyze software problems. |

|                                |                                                                                                                                                                                                                                                                                                                                                                                                                                                                                        |
|--------------------------------|----------------------------------------------------------------------------------------------------------------------------------------------------------------------------------------------------------------------------------------------------------------------------------------------------------------------------------------------------------------------------------------------------------------------------------------------------------------------------------------|
| Software-caused system crashes | <p>Check the following software items:</p> <ul style="list-style-type: none"> <li>• Is the problem only with one application program?</li> <li>• Is the problem only with one device?</li> <li>• Does the problem occur on a recently installed program?</li> <li>• Was the program recently patched or modified in any way?</li> <li>• Is the problem associated with any communication lines?</li> <li>• Check for static discharge occurring at the time of the failure.</li> </ul> |
|--------------------------------|----------------------------------------------------------------------------------------------------------------------------------------------------------------------------------------------------------------------------------------------------------------------------------------------------------------------------------------------------------------------------------------------------------------------------------------------------------------------------------------|

---

## Linux problem isolation procedure

Use this procedure when servicing a Linux partition or a server that has Linux as its only operating system.

### **DANGER**When working on or around the system, observe the following precautions:

Electrical voltage and current from power, telephone, and communication cables are hazardous. To avoid a shock hazard:

- Connect power to this unit only with the provided power cord. Do not use the provided power cord for any other product.
- Do not open or service any power supply assembly.
- Do not connect or disconnect any cables or perform installation, maintenance, or reconfiguration of this product during an electrical storm.
- The product might be equipped with multiple power cords. To remove all hazardous voltages, disconnect all power cords.
- Connect all power cords to a properly wired and grounded electrical outlet. Ensure that the outlet supplies proper voltage and phase rotation according to the system rating plate.
- Connect any equipment that will be attached to this product to properly wired outlets.
- When possible, use one hand only to connect or disconnect signal cables.
- Never turn on any equipment when there is evidence of fire, water, or structural damage.
- Disconnect the attached power cords, telecommunications systems, networks, and modems before you open the device covers, unless instructed otherwise in the installation and configuration procedures.
- Connect and disconnect cables as described in the following procedures when installing, moving, or opening covers on this product or attached devices.

To Disconnect:

1. Turn off everything (unless instructed otherwise).
2. Remove the power cords from the outlets.
3. Remove the signal cables from the connectors.
4. Remove all cables from the devices

To Connect:

1. Turn off everything (unless instructed otherwise).
2. Attach all cables to the devices.
3. Attach the signal cables to the connectors.
4. Attach the power cords to the outlets.
5. Turn on the devices.

(D005)

These procedures define the steps to take when servicing a Linux partition or a server that has Linux as its only operating system.

**Note:** If the server is attached to an HMC and Service Focal Point is enabled, the various codes that might display on the HMC are all listed as reference codes by Service Focal Point (SFP). Use the following table to help you identify the type of error information that might be displayed when you are using this procedure.

| Number of digits in reference code | Reference code          | Name or code type            |
|------------------------------------|-------------------------|------------------------------|
| Any                                | Contains # (pound sign) | Menu goal                    |
| Any                                | Contains - (hyphen)     | Service request number (SRN) |
| 5                                  | Does not contain # or - | SRN                          |
| 8                                  | Does not contain # or - | Service reference code (SRC) |

1. Is the server managed by an HMC that is running Service Focal Point (SFP)?

No

Go to step 3.

Yes

Go to step 2.

2. Servers with Service Focal Point

Look at the service action event log in SFP for errors. Focus on those errors with a timestamp near the time at which the error occurred. Follow the steps indicated in the error log entry to resolve the problem. If the problem is not resolved, continue with step 3.

3. Look for and record all reference code information or software messages on the operator panel and in the service processor error log (which is accessible by viewing the ASMI menus).
4. Choose a Linux partition that is running correctly (preferably the partition with the problem).

#### Is Linux usable in any partition with Linux installed?

No

Go to step 11.

Yes

Go to step 5.

5. Do the following steps:

**Attention:** Items 5 through 16 must be performed on a server or partition running the Linux operating system.

- a. Determine if there is a file named platform under /var/log directory of the server or partition. Log into the server or partition as the root user and enter the following command:

```
ls -l /var/log/platform
```

Does the /var/log/platform file exist?

No

Continue with substep 5.b.

Yes

Go to substep 5.c.

- b. Record that, for this Linux partition, you performed substep 5.b of 5 for later steps. Examine the Linux system log by entering the following command:

```
cat /var/log/messages |grep RTAS |more
```

Linux run-time RTAS error messages are logged in the messages file under /var/log. The following is an example of the Linux system RTAS error log messages.

### Service provider information

```
Aug 27 18:13:41 rasler kernel: RTAS: ----- event-scan begin -----
Aug 27 18:13:41 rasler kernel: RTAS: Location Code: U0.1-P1-C1
Aug 27 18:13:41 rasler kernel: RTAS: WARNING: (FULLY RECOVERED) type: INTERN_DEV_FAIL
Aug 27 18:13:41 rasler kernel: RTAS: initiator: UNKNOWN target: UNKNOWN
Aug 27 18:13:41 rasler kernel: RTAS: Status: predictive new
Aug 27 18:13:41 rasler kernel: RTAS: Date/Time: 20020827 18134000
Aug 27 18:13:41 rasler kernel: RTAS: CPU Failure
Aug 27 18:13:41 rasler kernel: RTAS: CPU id: 0
Aug 27 18:13:41 rasler kernel: RTAS: Failing element: 0x0000
Aug 27 18:13:41 rasler kernel: RTAS: A reboot of the system may correct the problem
Aug 27 18:13:41 rasler kernel: RTAS: ----- event-scan end -----
```

### Did you find any RTAS error log messages that are similar to the above messages?

No

Go to [Using AIX online and standalone diagnostics](#) and run the standalone diagnostics on the server or partition. If you receive a reference code go to the [reference code list](#). If you cannot determine the problem using the diagnostic programs, contact your next level of support.

Yes

Go to step 6.

- c. Record that for this Linux partition, you performed substep 5.c of 5 for later steps.

Use the following command to list diagela messages recorded in the Linux system log:

```
cat /var/log/platform |grep diagela |more
```

Linux run-time diagela error messages are logged in the platform file under /var/log.

The following is an example of the Linux system error log diagela messages.

```
Aug 13 09:38:45 larry diagela: 08/13/2003 09:38:44
Aug 13 09:38:45 larry diagela: Automatic Error Log Analysis has detected a problem.
Aug 13 09:38:45 larry diagela: Aug 13 09:38:45 larry diagela: The Service Request
Number(s)/Probable Cause(s)
Aug 13 09:38:45 larry diagela: (causes are listed in descending order of probability):
Aug 13 09:38:45 larry diagela:
Aug 13 09:38:45 larry diagela: 651-880: The CEC or SPCN reported an error. Report the
SRN and the following reference and physical location codes to your service provider.
Aug 13 09:38:45 larry diagela: Location: n/a FRU: n/a Ref-Code: B1004699
Aug 13 09:38:45 larry diagela:
Aug 13 09:38:45 larry diagela: Analysis of Error log sequence number: 3
Aug 29 07:13:04 larry diagela: 08/29/2003 07:13:04
Aug 29 07:13:04 larry diagela: Automatic Error Log Analysis has detected a problem.
Aug 29 07:13:04 larry diagela:
Aug 29 07:13:04 larry diagela: The Service Request Number(s)/Probable Cause(s)
Aug 29 07:13:04 larry diagela: (causes are listed in descending order of probability):
Aug 29 07:13:04 larry diagela:
Aug 29 07:13:04 larry diagela: 651-880: The CEC or SPCN reported an error. Report the
SRN and the following reference and physical location codes to your service provider.
Aug 29 07:13:04 larry diagela: Location: U0.1-F4 FRU: 09P5866 Ref-Code: 10117661
Aug 29 07:13:04 larry diagela:
Aug 29 07:13:04 larry diagela: Analysis of /var/log/platform sequence number: 24
Sep 4 06:00:55 larry diagela: 09/04/2003 06:00:55
Sep 4 06:00:55 larry diagela: Automatic Error Log Analysis reports the following:
Sep 4 06:00:55 larry diagela:
Sep 4 06:00:55 larry diagela: 651204 ANALYZING SYSTEM ERROR LOG
Sep 4 06:00:55 larry diagela: A loss of redundancy on input power was detected.
Sep 4 06:00:55 larry diagela:
Sep 4 06:00:55 larry diagela: Check for the following:
Sep 4 06:00:55 larry diagela: 1. Loose or disconnected power source connections.
Sep 4 06:00:55 larry diagela: 2. Loss of the power source.
Sep 4 06:00:55 larry diagela: 3. For multiple enclosure systems, loose or
Sep 4 06:00:55 larry diagela: disconnected power and/or signal connections
Sep 4 06:00:55 larry diagela: between enclosures.
Sep 4 06:00:55 larry diagela:
Sep 4 06:00:55 larry diagela: Supporting data:
Sep 4 06:00:55 larry diagela: Ref. Code: 10111520
Sep 4 06:00:55 larry diagela: Location Codes: P1 P2
Sep 4 06:00:55 larry diagela:
Sep 4 06:00:55 larry diagela: Analysis of /var/log/platform sequence number: 13
```

### Service provider information

Also use the following command to list RTAS messages recorded in the Linux system log:

```
cat /var/log/platform |grep RTAS |more
```

Linux RTAS error messages are logged in the platform file under /var/log. The following is an example of RTAS messages in the Linux system error log.

```
Aug 27 12:16:33 larry kernel: RTAS: 15 ----- RTAS event begin -----
Aug 27 12:16:33 larry kernel: RTAS 0: 04440040 000003f8 96008508 19155800
Aug 27 12:16:33 larry kernel: RTAS 1: 20030827 00000001 20000000 00000000
Aug 27 12:16:33 larry kernel: RTAS 2: 00000000 00000000 00000000 00000000
Aug 27 12:16:33 larry kernel: RTAS 3: 49424d00 55302e31 2d463400 00503034
Aug 27 12:16:33 larry kernel: RTAS 4: 10117661 04a0005d 10110000 00000000
Aug 27 12:16:33 larry kernel: RTAS 5: 00007701 000000e0 00000003 000000e3
Aug 27 12:16:33 larry kernel: RTAS 6: 00000000 01000000 00000000 31303131
Aug 27 12:16:33 larry kernel: RTAS 7: 37363631 20202020 20202020 55302e31
Aug 27 12:16:33 larry kernel: RTAS 8: 2d463420 20202020 20202020 03705a39
Aug 27 12:16:33 larry kernel: RTAS 9: 00000000 00000000 00000000 00000000
Aug 27 12:16:33 larry kernel: RTAS 10: 00000000 00000000 00000000 00000000
Aug 27 12:16:33 larry kernel: RTAS 11: 00000000 00000000 00000000 00000000
Aug 27 12:16:33 larry kernel: RTAS 12: 00000000 00000000 00000000 00000000
Aug 27 12:16:33 larry kernel: RTAS 13: 00000000 00000000 00000000 00000000
Aug 27 12:16:33 larry kernel: RTAS 14: 00000000 00000000 00000000 00000000
Aug 27 12:16:33 larry kernel: RTAS 15: 00000000 00000000 00000000 00000000
Aug 27 12:16:33 larry kernel: RTAS 16: 00000000 00000000 00000000 00000000
Aug 27 12:16:33 larry kernel: RTAS 17: 00000000 00000000 00000000 00000000
Aug 27 12:16:33 larry kernel: RTAS 18: 00000000 00000000 00000000 00000000
Aug 27 12:16:33 larry kernel: RTAS 19: 00000000 00000000 00000000 00000000
Aug 27 12:16:33 larry kernel: RTAS 20: 00000000 00000000 00000000 00000000
Aug 27 12:16:33 larry kernel: RTAS 21: 00000000 00000000 00000000 00000000
Aug 27 12:16:33 larry kernel: RTAS 22: 00000000 00000000 00000000 00000000
Aug 27 12:16:33 larry kernel: RTAS 23: 00000000 00000000 00000000 00000000
Aug 27 12:16:33 larry kernel: RTAS 24: 00000000 00000000 00000000 00000000
Aug 27 12:16:33 larry kernel: RTAS 25: 00000000 00000000 00000000 00000000
Aug 27 12:16:33 larry kernel: RTAS 26: 00000000 00000000 00000000 00000000
Aug 27 12:16:33 larry kernel: RTAS 27: 00000000 00000000 00000000 00000000
Aug 27 12:16:33 larry kernel: RTAS 28: 00000000 00000000 00000000 00000000
Aug 27 12:16:33 larry kernel: RTAS 29: 00000000 00000000 00000000 00000000
Aug 27 12:16:33 larry kernel: RTAS 30: 00000000 00000000 00000000 00000000
Aug 27 12:16:33 larry kernel: RTAS 31: 00000000 00000000 00000000 00000000
Aug 27 12:16:33 larry kernel: RTAS 32: 00000000 00000000 00000000 00000000
Aug 27 12:16:33 larry kernel: RTAS 33: 00000000 00000000 00000000 00000000
Aug 27 12:16:33 larry kernel: RTAS 34: 00000000 00000000 00000000 00000000
Aug 27 12:16:33 larry kernel: RTAS 35: 00000000 00000000 00000000 00000000
Aug 27 12:16:33 larry kernel: RTAS 36: 00000000 00000000 00000000 00000000
Aug 27 12:16:33 larry kernel: RTAS 37: 00000000 00000000 00000000 00000000
Aug 27 12:16:33 larry kernel: RTAS 38: 00000000 00000000 00000000 00000000
Aug 27 12:16:33 larry kernel: RTAS 39: 00000000 00000000 00000000 00000000
Aug 27 12:16:33 larry kernel: RTAS 40: 00000000 00000000 00000000 00000000
Aug 27 12:16:33 larry kernel: RTAS 41: 00000000 00000000 00000000 00000000
Aug 27 12:16:33 larry kernel: RTAS 42: 00000000 00000000 00000000 00000000
Aug 27 12:16:33 larry kernel: RTAS 43: 00000000 00000000 00000000 00000000
Aug 27 12:16:33 larry kernel: RTAS 44: 00000000 00000000 00000000 00000000
Aug 27 12:16:33 larry kernel: RTAS 45: 00000000 00000000 00000000 00000000

Aug 27 12:16:33 larry kernel: RTAS 46: 00000000 00000000 00000000 00000000
Aug 27 12:16:33 larry kernel: RTAS 47: 00000000 00000000 00000000 00000000
Aug 27 12:16:33 larry kernel: RTAS 48: 00000000 00000000 00000000 00000000
Aug 27 12:16:33 larry kernel: RTAS 49: 00000000 00000000 00000000 00000000
Aug 27 12:16:33 larry kernel: RTAS 50: 00000000 00000000 00000000 00000000
Aug 27 12:16:33 larry kernel: RTAS 51: 00000000 00000000 00000000 00000000
Aug 27 12:16:33 larry kernel: RTAS 52: 00000000 00000000 00000000 00000000
Aug 27 12:16:33 larry kernel: RTAS 53: 00000000 00000000 00000000 00000000
Aug 27 12:16:33 larry kernel: RTAS 54: 00000000 00000000 00000000 00000000
Aug 27 12:16:33 larry kernel: RTAS 55: 00000000 00000000 00000000 00000000
Aug 27 12:16:33 larry kernel: RTAS 56: 00000000 00000000 00000000 00000000
Aug 27 12:16:33 larry kernel: RTAS 57: 00000000 00000000 00000000 00000000
Aug 27 12:16:33 larry kernel: RTAS 58: 00000000 00000000 00000000 00000000
Aug 27 12:16:33 larry kernel: RTAS 59: 00000000 00000000 00000000 00000000
Aug 27 12:16:33 larry kernel: RTAS 60: 00000000 00000000 00000000 00000000
Aug 27 12:16:33 larry kernel: RTAS 61: 00000000 00000000 00000000 00000000
Aug 27 12:16:33 larry kernel: RTAS 62: 00000000 00000000 00000000 00000000
```

### Service provider information

```
d. Aug 27 12:16:33 larry kernel: RTAS 63: 00000000 00000000 00000000 00020000
   Aug 27 12:16:33 larry kernel: RTAS: 15 ----- RTAS event end -----
```

Reference codes and location codes may appear as RTAS messages. The extended data is also provided in the form of an RTAS message. The extended data contains other reference code words that help in isolating the correct FRUs. The start of the extended data is marked, for example, by the line:

```
Aug 27 12:16:33 larry kernel: RTAS: 15 ----- RTAS event begin
-----
```

The number after the colon is a sequence number that correlates this data with any diagela data having the same sequence number. The end of the extended data is marked by the line:

```
Aug 27 12:16:33 larry kernel: RTAS: 15 ----- RTAS event end -----
```

with the same sequence number. Word 13 and word 19 are found in the RTAS messages. For example, to find word 13, first find the reference code in the left column of words of the extended data, 10117661. In this example, we find the reference code to the right of "RTAS 4:". This is also word 11. To get word 13, 10110000, simply count the words left-to-right, beginning at word 11.

6. If you performed substep 5.b of step 5, then record any RTAS messages found in the Linux system log in step 5. Or, if you performed substep 5.c of step 5, then record any RTAS and diagela messages found in the Linux system log in step 5, and also record any extended data found in the RTAS messages, especially word 13 and word 19. Ignore all other messages in the Linux system log.

If the system is configured with more than one logical partition with Linux installed, repeat step 5 and step 6 for all logical partitions that have Linux installed.

7. If you performed substep 5.c of step 5 for the current Linux partition, go to step 8, and when asked in step 8, do not record any RTAS messages from step 7 for the current Linux partition.

Examine the Linux boot (IPL) log by logging in to the system as the root user and entering the following command:

```
cat /var/log/boot.msg |grep RTAS |more
```

Linux boot (IPL) error messages are logged into the boot.msg file under /var/log. The following is an example of the Linux boot error log.

```
RTAS daemon started
RTAS: ----- event-scan begin -----
RTAS: Location Code: U0.1-F3
RTAS: WARNING: (FULLY RECOVERED) type: SENSOR
RTAS: initiator: UNKNOWN target: UNKNOWN
RTAS: Status: bypassed new
RTAS: Date/Time: 20020830 14404000
RTAS: Environment and Power Warning
RTAS: EPOW Sensor Value: 0x00000001
RTAS: EPOW caused by fan failure
RTAS: ----- event-scan end -----
```

8. Record any RTAS messages found in the Linux boot (IPL) log in step 7. Ignore all other messages in the Linux boot (IPL) log. If the system is configured with more than one logical partition with Linux installed, repeat step 7 and step 8 for all logical partitions that have Linux installed.
9. If you performed substep 5.c of 5 for the current Linux partition, go to step 10, and when asked in step 10, do not record any additional extended data from step 7 for the current Linux partition.

Examine the extended data in both logs.

The following is an example of the Linux extended data.

```
<3>RTAS daemon started
<3>RTAS: ----- event-scan begin -----
```

## Service provider information

```

<3>RTAS: Location Code: U0.1-P1-C2
<4>RTAS: Log Debug: 04
4b2726fb04a00011702c001400000000000000000000000000000000f1800001001801d3fffffffff010000000000000042343138
20202020383030343236464238454134303030303 030303030303030
<4>RTAS: Log Debug: D2
5046413405020d0a000001000271400100000033434d50204441544100000100000000000010000f180000153595
3204441544100000000000000000200216271501050920021627150105092002063715010509535243204441544170
2c0014000000000000000020018820201d38200
000
00000000000000000000004350542044415441702cfff08000000001c000000702cf0080000000080000000702cf10070
2cf200702c000400000800702c01040bf2002e702c02040c1ffffbf702c0300702c1000702c11040bf2002e702c12040
c1ffffbf702c1300702ca000702ca10800000000000a03c702ca20800
0000a03c702cb20800
000702c31080000000000000000000003702c320800000000000000000000007b702c8000702c81080000000020e27a39702c820800
000000ffffeffff702cd000702cd1080000000010004010702cd208000000007777f3ffffffffffffffffffffffffffff
ff
<3>RTAS: WARNING: (FULLY RECOVERED) type: INTERN_DEV_FAIL
<3>RTAS: initiator: UNKNOWN target: UNKNOWN
<3>RTAS: Status: unrecoverable new
<3>RTAS: Date/Time: 20020905 15372200
<3>RTAS: CPU Failure
<3>RTAS: Internal error (not cache)
<3>RTAS: CPU id: 0
<3>RTAS: Failing element: 0x0000
<3>RTAS: ----- event-scan end -----

```

10. Record any extended data found in the Linux system log in Step 5 or the Linux boot (IPL) log in step 7. Be sure to record word 13.

**Note:** The line(s) in the Linux extended data that begin with "<4>RTAS: Log Debug: 04" contain the reference code listed in the next 8 hex characters. In the previous example, "4b27 26fb" is a reference code. The reference code is also known as word 11. Each 4 bytes after the reference code in the Linux extended data is another word (for example, "04a0 0011" is word 12, and "702c 0014" is word 13, and so on).

If the system is configured with more than one logical partition with Linux installed, repeat step 9 and step 10 for all logical partitions that have Linux installed.

11. Were any reference codes or checkpoints recorded in steps 3, 6, 8, or 10?

No

Go to step 12.

Yes

Go to the [Linux fast-path problem isolation](#) with each reference code that was recorded. Perform the indicated actions one at a time for each reference code until the problem has been corrected. If all recorded reference codes have been processed and the problem has not been corrected, go to step 12.

12. If no additional error information is available and the problem has not been corrected, do the following:

- a. Shut down the system.

- b. If an HMC is not attached, see [Accessing the Advanced System Management Interface \(ASMI\)](#) for instructions to access the ASMI.

**Note:** The ASMI functions can also be accessed by using a personal computer connected to system port 1.

You need a personal computer (and cable, part number 62H4857) capable of connecting to system port 1 on the system unit. (The Linux login prompt cannot be seen on a personal computer connected to system port 1.) If the ASMI functions are not otherwise available, use the following procedure:

- i. Attach the personal computer and cable to system port 1 on the system unit.
- ii. With 01 displayed in the operator panel, press a key on the virtual terminal on the personal computer. The service ASMI menus are available on the attached personal computer.

iii. If the service processor menus are not available on the personal computer, perform the following steps:

1. Examine and correct all connections to the service processor.
2. Replace the service processor.

**Note:** The service processor might be contained on a separate card or board; in some systems, the service processor is built into the system backplane. Contact your next level of support for help before replacing a system backplane.

c. Examine the service processor error log. Record all reference codes and messages written to the service processor error log. Go to step 13.

13. Were any reference codes recorded in step 12?

No

Go to step 21.

Yes

Go to the [Linux fast-path problem isolation](#) with each reference code or symptom you have recorded. Perform the indicated actions, one at a time, until the problem has been corrected. If all recorded reference codes have been processed and the problem has not been corrected, go to 21.

14. Reboot the system and bring all partitions to the login prompt. If Linux is not usable in all partitions, go to step 18.

15. Use the `lscfg` command to list all resources assigned to all partitions. Record the adapter and the partition for each resource.

16. To determine if any device(s) or adapter(s) are missing, compare the list of partition assignments, and resources found, to the customer's known configuration. Record the location of any missing devices. Also record any differences in the descriptions or the locations of devices.

You may also compare this list of resources that were found to a prior version of the device tree as follows:

**Note:** Every time that the partition is booted, the `update-device-tree` command is run and the device tree is stored in the `/var/lib/lsvpd/` directory in a file with the file name `device-tree-YYYY-MM-DD-HH:MM:SS`, where YYYY is the year, MM is the month, DD is the day, and HH, MM, and SS are the hour, minute and second, respectively, of the date of creation.

◆ At the command line, type the following:

```
cd /var/lib/lsvpd/
```

◆ At the command line, type the following:

```
lscfg -vpd db-2003-03-31-12:26:31.
```

This displays the device tree created on 03/31/2003 at 12:26:31.

The `diff` command offers a way to compare the output from a current `lscfg` command to the output from an older `lscfg` command. If the file names for the current and old device trees are `current.out` and `old.out`, respectively, type: `diff old.out current.out`. Any lines that exist in the old, but not in the current will be listed and preceded by a less-than symbol (<). Any lines that exist in the current, but not in the old will be listed and preceded by a greater-than symbol (>). Lines that are the same in both files are not listed; for example, files that are identical will produce no output from the `diff` command. If the location or description changes, lines preceded by both < and > will be output.

If the system is configured with more than one logical partition with Linux installed, repeat 15 and 16 for all logical partitions that have Linux installed.

17. Was the location of one and only one device recorded in 16?

No

If you previously answered Yes to step 17, return the system to its original configuration. This ends the procedure. Go to [MAP 0410: Repair checkout](#).

Yes

Perform the following steps one at a time. Power off the system before performing each step. After performing each step, power on the system and go to step 14.



- a. Check all connections from the system to the device.
  - b. Replace the device (for example, tape or DASD)
  - c. If applicable, replace the device backplane.
  - d. Replace the device cable.
  - e. Replace the adapter.
  - f. If the adapter resides in an I/O drawer, replace the I/O backplane.
  - g. If the device adapter resides in the CEC, replace the I/O riser card, or the CEC backplane in which the adapter is plugged.
  - h. Call service support. Do not go to step 14.
18. Does the system appear to stop or hang before reaching the login prompt or did you record any problems with resources in step 16?

**Note:** If the system console or VTERM window is always blank, choose NO. If you are sure the console or VTERM is operational and connected correctly, answer the question for this step.

No  
Go to step 19.

Yes  
There may be a problem with an I/O device. Go to [PFW1542: I/O problem isolation procedure](#). When instructed to boot the system, boot a full system partition.

19. Boot the standalone diagnostics, refer to [Using AIX online and standalone diagnostics](#). Run diagnostics in problem determination mode on all resources. Be sure to boot a full system partition. Ensure that AIX diagnostics were run on all known resources. You may need to select each resource individually and run diagnostics on each resource one at a time.

#### Did standalone diagnostics find a problem?

No  
Go to step 23.

Yes  
Go to the [Reference codes](#) and perform the actions for each reference code you have recorded. For each reference code not already processed in step 17, repeat this action until the problem has been corrected. Perform the indicated actions, one at a time. If all recorded reference codes have been processed and the problem has not been corrected, go to step 23.

20. Does the system have Linux installed on one or more partitions?

No  
Return to the [Start-of-call isolation procedure](#).

Yes  
Go to step 3.

21. Were any location codes recorded in steps 3, 6, 8, 10, 11, or 12?

No  
Go to step 14.

Yes  
Replace, one at a time, all parts whose location code was recorded in steps 3, 6, 8, 10, 11, or 12 that have not been replaced. Power off the system before replacing a part. After replacing the part, power on the system to check if the problem has been corrected. Go to step 22 when the problem has been corrected, or all parts in the location codes list have been replaced.

22. Was the problem corrected in step 21?

No  
Go to step 14.

Yes  
Return the system to its original configuration. This ends the procedure. Go to [MAP 0410: Repair checkout](#).

23. Were any other symptoms recorded in step 3?

No  
Call support.

Yes  
Go to the [Start-of-call isolation procedure](#) with each symptom you have recorded. Perform the indicated actions for all recorded symptoms, one at a time, until the problem has been corrected. If all recorded symptoms have been processed and the problem has not been corrected, call your next level of support.

## System unit problem determination

Use this procedure to obtain a reference code if the customer did not provide you with one, or you are unable to load server diagnostics.

If you are able to load the diagnostics, go to [AIX partition problem determination](#).

The service processor may have recorded one or more symptoms in its error log. Examine this error log before proceeding (see the [Advanced System Management Interface](#) for details). The server may have been set up by using the HMC. Check the Service Action Event (SAE) log in the Service Focal Point. The SAE log may have recorded one or more symptoms in the Service Focal Point. To avoid unnecessary replacement of the same FRU for the same problem, it is necessary to check the SAE log for evidence of prior service activity on the same subsystem.

The service processor may have been set by the user to monitor system operations and to attempt recoveries. You can disable these actions while you diagnose and service the system. If the system maintenance policies were saved using the "save/restore hardware maintenance policies", all the settings of the service processor (except language) were saved and you can use the same service aid to restore the settings at the conclusion of your service action.

If you disable the service processor settings, note their current settings so that you can restore when you are done.

If the system is set to power on using one of the parameters in the following table, disconnect the modem to prevent incoming signals that could cause the system to power on.

Following are the service processor settings. See the [Advanced System Management Interface](#) information for more information about the service processor settings.

Table 1. Service processor settings

| Setting                                                | Description                                                                                                                                                     |
|--------------------------------------------------------|-----------------------------------------------------------------------------------------------------------------------------------------------------------------|
| Monitoring (also called surveillance)                  | From the ASMI menu, expand the System Configuration menu, then click on Monitoring. Disable both types of surveillance.                                         |
| Auto power restart (also called unattended start mode) | From the ASMI menu, expand Power/Restart Control, then click on Auto Power Restart, and set it to disabled.                                                     |
| Wake on LAN                                            | From the ASMI menu, expand Wake on LAN, and set it to disabled                                                                                                  |
| Call out                                               | From the ASMI menu, expand the Service Aids menu, then click on Call-Home/Call-In Setup. Set the call-home system port and the call-in system port to disabled. |

### Step 1020-1

Be prepared to record code numbers to help analyze a problem.

## Analyze a failure to load the diagnostic programs

Follow these steps to analyze a failure to load the diagnostic programs.

**Note:** Be prepared to answer questions regarding the control panel and to perform certain actions based on displayed POST indicators. Please be observant of these conditions.

1. Run diagnostics on any partition. Find your symptom in the following table, then follow the instructions given in the Action column. If no fault is identified, continue to the next step.
2. Run diagnostics on the failing partition. Find your symptom in the following table, then follow the instructions given in the Action column. If no fault is identified, continue to the next step.
3. Power off the system. Refer to [Stop the system](#).
4. Load the standalone diagnostics in service mode to test the full system partition; refer to [Using AIX online and standalone diagnostics](#)
5. Wait until the diagnostics are loaded or the system appears to stop. If you receive an error code or if the system stops before diagnostics are loaded, find your symptom in the following table, then follow the instructions given in the Action column. If no fault is identified, continue to the next step.
6. Run the standalone diagnostics on the entire system. Find your symptom in the following table, then follow the instructions given in the Action column. If no fault is identified, call service support for assistance.

| Symptom                                                                               | Action                                                                                                                                                                                                                                                                                                                                                                                                                                                |
|---------------------------------------------------------------------------------------|-------------------------------------------------------------------------------------------------------------------------------------------------------------------------------------------------------------------------------------------------------------------------------------------------------------------------------------------------------------------------------------------------------------------------------------------------------|
| One or more logical partitions does not boot.                                         | <ol style="list-style-type: none"> <li>a. Check service processor error log. If an error is indicated, go to <a href="#">Start of call procedure</a>.</li> <li>b. Check the Serviceable action event log, go to <a href="#">Start of call procedure</a>.</li> <li>c. Go to <a href="#">Problems with loading and starting the operating system</a>.</li> </ol>                                                                                        |
| The rack identify LED does not operate properly.                                      | Go to <a href="#">Start of call procedure</a> .                                                                                                                                                                                                                                                                                                                                                                                                       |
| The system stopped and a system reference code is displayed on the operator panel.    | Go to <a href="#">Start of call procedure</a> .                                                                                                                                                                                                                                                                                                                                                                                                       |
| The system stops with a prompt to enter a password.                                   | Enter the password. You cannot continue until a correct password has been entered. When you have entered a valid password, go to the beginning of this table and wait for one of the other conditions to occur.                                                                                                                                                                                                                                       |
| The diagnostic operating instructions are displayed.                                  | Go to <a href="#">MAP 0020: AIX or Linux problem determination procedure</a> .                                                                                                                                                                                                                                                                                                                                                                        |
| The power good LED does not come on or does not stay on, or you have a power problem. | Go to <a href="#">Power problems</a> .                                                                                                                                                                                                                                                                                                                                                                                                                |
| The system login prompt is displayed.                                                 | <p>You may not have pressed the correct key or you may not have pressed the key soon enough when you were to trying to indicate a service mode IPL of the diagnostic programs. If this is the case, start again at the beginning of this step.</p> <p><b>Note:</b> Perform the system shutdown procedure before turning off the system.</p> <p>If you are sure you pressed the correct key in a timely manner, go to <a href="#">Step 1020-2</a>.</p> |
| The system does not respond when the password is entered.                             | Go to <a href="#">Step 1020-2</a> .                                                                                                                                                                                                                                                                                                                                                                                                                   |

Service provider information

|                                                                                                                                |                                                                                                                                                                                                                                                                                                                                                                                                                                                                                                                                                                                                                                                                                                                                                                                                                                                                                                                                                                   |
|--------------------------------------------------------------------------------------------------------------------------------|-------------------------------------------------------------------------------------------------------------------------------------------------------------------------------------------------------------------------------------------------------------------------------------------------------------------------------------------------------------------------------------------------------------------------------------------------------------------------------------------------------------------------------------------------------------------------------------------------------------------------------------------------------------------------------------------------------------------------------------------------------------------------------------------------------------------------------------------------------------------------------------------------------------------------------------------------------------------|
| <p>The system stopped. A POST indicator is displayed on the system console and an eight-digit error code is not displayed.</p> | <p>If the POST indicator represents:</p> <ul style="list-style-type: none"> <li>a. Memory, go to <a href="#">PFW1548: Memory and processor subsystem problem isolation procedure</a>.</li> <li>b. Keyboard <ul style="list-style-type: none"> <li>i. Replace the keyboard cable.</li> <li>ii. Replace the keyboard.</li> <li>iii. Replace the service processor. Location is model dependent.</li> <li>iv. Go to <a href="#">PFW1542: I/O problem isolation procedure</a>.</li> </ul> </li> <li>c. Network, go to <a href="#">PFW1542: I/O problem isolation procedure</a>.</li> <li>d. SCSI, go to <a href="#">PFW1542: I/O problem isolation procedure</a>.</li> <li>e. Speaker <ul style="list-style-type: none"> <li>i. Replace the operator panel. Location is model dependent.</li> <li>ii. Replace the service processor. Location is model dependent.</li> <li>iii. Go to <a href="#">PFW1542: I/O problem isolation procedure</a></li> </ul> </li> </ul> |
| <p>The System Management Services menu is displayed.</p>                                                                       | <p>Go to <a href="#">PFW1542: I/O problem isolation procedure</a>.</p>                                                                                                                                                                                                                                                                                                                                                                                                                                                                                                                                                                                                                                                                                                                                                                                                                                                                                            |
| <p>All other symptoms.</p>                                                                                                     | <p>If you were directed here from the Entry MAP, go to <a href="#">PFW1542: I/O problem isolation procedure</a>. Otherwise, find the symptom in the <a href="#">Start of call procedure</a>.</p>                                                                                                                                                                                                                                                                                                                                                                                                                                                                                                                                                                                                                                                                                                                                                                  |

Step 1020-2

Use this procedure to analyze a keyboard problem.

Find the type of keyboard you are using in the following table; then follow the instructions given in the Action column.

| <b>Keyboard Type</b>                                                                                                           | <b>Action</b>                                                                                           |
|--------------------------------------------------------------------------------------------------------------------------------|---------------------------------------------------------------------------------------------------------|
| <p>Type 101 keyboard (U.S.). Identified by the size of the Enter key. The Enter key is in only one horizontal row of keys.</p> | <p>Record error code M0KB D001; then go to <a href="#">Step 1020-3</a>.</p>                             |
| <p>Type 102 keyboard (W.T.). Identified by the size of the Enter key. The Enter key extends into two horizontal rows.</p>      | <p>Record error code M0KB D002; then go to <a href="#">Step 1020-3</a>.</p>                             |
| <p>Type 106 keyboard. (Identified by the Japanese characters.)</p>                                                             | <p>Record error code M0KB D003; then go to <a href="#">Step 1020-3</a>.</p>                             |
| <p>ASCII terminal keyboard</p>                                                                                                 | <p>Go to the documentation for this type of ASCII terminal and continue with problem determination.</p> |

Step 1020-3

Perform the following steps:

1. Find the 8-digit error code in [Reference codes](#).

**Note:** If you do not locate the 8-digit code, look for it in one of the following places:

- ◆ Any supplemental service manuals for attached devices
- ◆ The diagnostic problem report screen for additional information
- ◆ The Service Hints service aid
- ◆ The CERADME file (by using the [Display service hints](#) service aid)

2. Perform the action listed.

Parent topic: [Detecting problems](#)

---

## Loading and Using the AIX online diagnostics or the standalone diagnostics

Use this procedure to check the server or partition for correct hardware operation after removing and replacing a part or installing a feature.

Parent topic: [Working with AIX diagnostics](#)

### Before you begin

- The AIX operating system must be installed on your server or the standalone diagnostics must be available from another source (CD or Network Installation Management (NIM) server) before you start this procedure.
- If this server is directly attached to another server or attached to a network, be sure communications with the other servers are stopped.
- This procedure requires use of all of the partition resources. No other activity can be running on the partition while you are performing this procedure.
- This procedure requires access to the server's system console which can be either a display attached to a graphics adapter or an HMC.

1. Does the server have AIX diagnostics preinstalled?

Yes:

If there is an HMC attached to the system, go to step 2. If an HMC is not attached to the system, go to step 4.

No:

If there is an HMC attached to the system, go to step 3. If an HMC is not attached to the system, go to step 5.

**Note:** If the server does not have an optical drive to load standalone diagnostics, go to step 7.

2. Using the HMC to load the online diagnostics in service mode

To run the online diagnostics in service mode from the boot hard disk, do the following:

If the system is powered down, go to substep 2.a. If the system is powered up, shut down the operating system loaded on the partition that will be running standalone diagnostics. Put the standalone diagnostic CD into the optical disk drive and then go to substep 2.h.

- a. Remove all tapes, diskettes, and optical media.
- b. If the ASMI is not available to power on the system, go to 2.d. If the ASMI is available to power on the system, go to [Controlling the system power](#)
- c. Ensure that the AIX operating system is loaded on the disk drive and is assigned to the correct partition.
- d. Slow boot can be set using the control panel. Use panel function 02 to set the system boot speed to S (slow). Refer to [Control panel functions](#) for more information.
- e. Highlight the desired system by right-clicking on or selecting the system in the Server and Partition: Server Management area. From the Server and Partition: Server Management

- menu, click on Selected.
- f. Select Power On.
- g. Enter any passwords that are requested.
- h. Go to your list of applicable partitions, click your left mouse button to select the partition that you will be booting standalone diagnostics from. After the partition has been selected, click your right mouse button to display a menu containing selectable tasks that can be done with the partition.
- i. Select **Activate**. Ensure that the partitions operating system has been shutdown before selecting the "Activate" option.

**Note:** After shutting down the operating system close the VTERM window by selecting the X box, located in the upper right corner of the window. You must close the VTERM window before accessing SMS. You are allowed one VTERM window opened at a time and when accessed SMS automatically opens its own VTERM window.

- j. From the Activate Logical Partition menu select **Advanced**.
- k. From the Activate Logical Partition (Advanced) menu, click on the Boot-mode box and select **SMS**, then click the **OK** button located at the bottom of the screen.
- l. From the Logical Partition menu, click on the box next to Open a Terminal Window or Console Session, (a check mark appears in the box). Click on the **OK** button located at the bottom of the screen.
- m. The Vterm screen appears. At the bottom of the Vterm screen the Power On Self Test (POST) indicators begin appearing one at a time. After the POST indicator word "keyboard" displays and before the last POST indicator word "speaker" displays, press the numeric "6" key to boot standalone diagnostics.

**Note:**

- ◇ This is a time critical step. You must press the numeric "6" key as indicated above or the system will boot up the operating system.
- ◇ If you are unable to load the diagnostics to the point where the DIAGNOSTIC OPERATING INSTRUCTIONS display, go to . [Using the HMC to load the standalone diagnostics from CD-ROM](#)

- n. Press **Enter**, when the Diagnostics Operating Instructions menu appears.
- o. From the Function Selection menu, choose the diagnostic selection that you want to perform.
- p. From the Define a System Console menu either type in or select VT320.
- q. To exit online diagnostics in service mode press the F10 key.
- r. Online diagnostics from service mode is now complete. You can now activate the partition to boot the operating system.

### 3. Using the HMC to load the standalone diagnostics from CD-ROM

To run the standalone diagnostics CD, assign an optical drive to the partition in which standalone diagnostics is to be run. Ask the customer to verify that an optical drive is assigned to the correct partition.

If the system is powered down, go to substep [3.a](#). If the system is powered up, shut down the operating system loaded on the partition that will be running standalone diagnostics. Put the standalone diagnostic CD into the optical disk drive and then go to substep [3.h](#).

- a. Remove all tapes, diskettes, and optical media.
- b. Ensure that the CD-ROM drive is assigned to the partition on which standalone diagnostics will be run.
- c. If the ASMI is not available to power on the system, go to [3.d](#). If the ASMI is available to power on the system, go to [Controlling the system power](#)
- d. Slow boot can be set using the control panel. Use panel function 02 to set the system boot speed to S (slow). Refer to [Control panel functions](#) for more information.
- e. Highlight the desired system by right-clicking on or selecting the system in the Server and Partition: Server Management area. From the Server and Partition: Server Management menu, click on Selected.
- f. Select Power On. As soon as the optical drive has power, insert the AIX standalone diagnostic CD into the optical drive.

- g. Enter any passwords that are requested.
- h. Go to your list of applicable partitions, click your left mouse button to select the partition that you will be booting standalone diagnostics from. After the partition has been selected, click your right mouse button to display a menu containing selectable tasks that can be done with the partition.
- i. Select **Activate**. Ensure that the partitions operating system has been shutdown before selecting the "Activate" option.

**Note:** After shutting down the operating system close the VTERM window by selecting the X box, located in the upper right corner of the window. You must close the VTERM window before accessing SMS. You are allowed one VTERM window opened at a time and when accessed SMS automatically opens its own VTERM window.

- j. From the Activate Logical Partition menu select **Advanced**.
- k. From the Activate Logical Partition (Advanced) menu, click on the Boot-mode box and select **SMS**, then click the **OK** button located at the bottom of the screen.
- l. From the Logical Partition menu, click on the box next to Open a Terminal Window or Console Session, (a check mark appears in the box). Click on the **OK** button located at the bottom of the screen.
- m. The Vterm screen appears. At the bottom of the Vterm screen the Power On Self Test (POST) indicators begin appearing one at a time. After the POST indicator word "keyboard" displays and before the last POST indicator word "speaker" displays, press the numeric "5" key to boot standalone diagnostics.

**Note:** This is a time critical step. You must press the numeric "5" key as indicated above or the system will boot up the operating system.

- n. Using the standalone diagnostics menus, follow the instructions to define a system console.
  - o. At the Define a System Console menu type in VT320.
  - p. The Function Selection menu appears, choose the standalone diagnostic selection that you want to perform.
  - q. To exit standalone diagnostics press the F10 key or simultaneously press the ESC and 0 keys.
  - r. To eject the CD from the optical drive type 99.
  - s. When asked if you want to halt or reboot, select **Halt**.
  - t. Standalone diagnostics from CD ROM is now complete. Remove the diagnostics CD ROM media from the optical disk drive. You can now activate the partition to boot the operating system.
4. Loading the online diagnostics on a system without an HMC attached

To run the online diagnostics in service mode from the boot hard disk, do the following:

- a. Stop all programs including the AIX operating system (get help if needed).
- b. Remove all tapes, diskettes, and optical media.
- c. Turn off the system unit power.
- d. If the ASMI is not available, skip to substep 4.e. If the ASMI is available, do the following:
  - i. Access the ASMI. Login with your user ID and password.
  - ii. On the welcome screen, click on Power/Restart Control.
  - iii. On the "Power/Restart Control" menu, click on Power On/Off System.
  - iv. On the "Power On/Off System" menu, set the system boot speed to "slow". Also verify that "Boot to System Hypervisor" is set to "Running".
  - v. Click on "Save Settings".
  - vi. Go to substep 4.g.
- e. Slow boot can be set using the control panel. Do the following:
  - ◊ Use panel function 02 to set the system boot speed to S (slow). Refer to [Control panel functions](#) for more information.
- f. Turn on the system unit power.
- g. After the keyboard POST indicator displays on the firmware console and before the last POST indicator (speaker) displays, press the numeric 6 key on either the directly attached keyboard or the ASCII terminal to indicate that a service mode boot should be initiated using the Customized service mode boot list.

- h. Enter any requested password.

**Note:** If you are unable to load the diagnostics to the point when the `DIAGNOSTIC OPERATING INSTRUCTIONS` display, call your service support center for assistance.

- i. Go to [Running system verification](#).

#### 5. Loading the standalone diagnostics on a system without an HMC attached

To run the standalone diagnostics from CD-ROM, do the following:

- a. Stop all programs including the AIX operating system (get help if needed).
- b. Remove all tapes, diskettes, and optical media.
- c. Turn off the system unit power.
- d. If the ASMI is not available, skip to substep 5.e. If the ASMI is available, do the following:
  - i. Access the ASMI. Login with your user ID and password.
  - ii. On the welcome screen, click on Power/Restart Control.
  - iii. On the "Power/Restart Control" menu, click on Power On/Off System.
  - iv. On the "Power On/Off System" menu, set the system boot speed to "slow". Also verify that Boot to System Hypervisor is set to Running.
  - v. Click on "Save Settings".
  - vi. Go to substep 5.f.
- e. Slow boot can be set using the control panel. Do the following:
  - ◇ Use panel function 02 to set the system boot speed to S (slow). Refer to Control panel functions for more information.
- f. Turn on the system unit power and immediately insert the diagnostics CD-ROM into the CD-ROM drive.
- g. After the keyboard POST indicator displays on the firmware console and before the last POST indicator (speaker) displays, press the numeric 5 key on either the directly attached keyboard or the ASCII terminal to indicate that a service mode boot should be initiated using the default service mode boot list.
- h. Enter any requested password.

**Note:** If you are unable to load the diagnostics to the point when the `DIAGNOSTIC OPERATING INSTRUCTIONS` display, call your support center for assistance.

- i. If you want to verify server or partition operations, go to [Running system verification](#).
- j. To exit standalone diagnostics and shut down the system, refer to [Powering off the system after running standalone diagnostics](#).

#### 6. Performing additional system verification To perform additional system verification, do the following:

- a. Press Enter to return to the Diagnostic Selection menu.
- b. To check other resources, select the resource. When you have checked all of the resources you need to check, go to [Stopping the diagnostics](#).

#### 7. Running Standalone Diagnostics from a Network Installation Management (NIM) Server with an HMC Attached to the System

A client system connected to a network with a Network Installation Management (NIM) server can boot standalone diagnostics from the NIM server if the client-specific settings on both the NIM server and client are correct.

#### Notes:

- a. All operations to configure the NIM server require root user authority.
- b. If you replace the network adapter in the client, the network-adapter hardware-address settings for the client must be updated on the NIM server.
- c. The Cstate for each standalone diagnostics client on the NIM server should be kept in the *diagnostic boot has been enabled* state.
- d. On the client system, the NIM server network adapter should be put in the bootlist after the boot disk drive. This allows the system to boot in standalone diagnostics from the NIM server if there is a problem booting from the disk drive. For information about setting the bootlist, see



## Accessing the Advanced System Management Interface.

For information about:

- ◆ Registering a client on the NIM server
- ◆ Enabling a client to run diagnostics from the NIM server

Refer to [Advanced NIM configuration tasks](#) information on the [AIX documentation Web site](#)

### NIM Server Configuration:

To verify that the client system is registered on the NIM server and the diagnostic boot is enabled, run the **lsnim -a Cstate -Z *ClientName*** command from the command line on the NIM server. Refer to the following table for system responses.

**Note:** The *ClientName* is the name of the system on which you want to run standalone diagnostics.

| System Response                                                                                                                        | Client Status                                                                                                                                                                                                                      |
|----------------------------------------------------------------------------------------------------------------------------------------|------------------------------------------------------------------------------------------------------------------------------------------------------------------------------------------------------------------------------------|
| #name:Cstate:<br>ClientName:diagnostic boot has been enabled:                                                                          | The client system is registered on the NIM server and enabled to run diagnostics from the NIM server.                                                                                                                              |
| #name:Cstate:<br>ClientName:ready for a NIM operation:<br><br>or<br><br>#name:Cstate:<br>ClientName:BOS installation has been enabled: | The client is registered on the NIM server but not enabled to run diagnostics from the NIM server.<br><br><b>Note:</b> If the client system is registered on the NIM server but Cstate has not been set, no data will be returned. |
| 0042-053 lsnim: there is no NIM object named " <i>ClientName</i> "                                                                     | The client is not registered on the NIM server.                                                                                                                                                                                    |

## 8. Client Configuration and Booting Standalone Diagnostics from the NIM Server

To run the standalone diagnostics from a NIM server, the network adapter from which you want to boot from the NIM server must be assigned to the partition in which you want to run standalone diagnostics. Ask the customer to verify that a network adapter is available to the partition before continuing.

If the system is powered down, do the following. If it is powered up, and you are activating a partition, go to substep [8.j](#).

To run standalone diagnostics on a client from the NIM server, do the following:

- a. Remove any removable media (tape or optical disc).
- b. Stop all programs including the operating system (get help if needed).
- c. If the ASMI is available, do the following. If the ASMI is not available, go to substep [8.d](#).
  - i. Access the ASMI. Login with your user ID and password.
  - ii. On the welcome screen, click on Power/Restart Control.
  - iii. On the Power/Restart Control menu, click on Power On/Off System.
  - iv. On the Power On/Off System menu, set the system boot speed to "slow". Also verify that "Boot to System Hypervisor" is set to "Running".
  - v. Click on Save Settings.
  - vi. Go to substep [8.e](#).
- d. Slow boot can be set using the control panel. Do the following:

- i. Use panel function 02 to set the system boot speed to S (slow). Refer to [Control panel functions](#) for more information.
- ii. Go to substep [8.e](#).
- e. If you are powering on the server, continue with substep [8.f](#). If you are activating a partition, go to substep [8.i](#).
- f. Highlight the desired system by right-clicking on or selecting the system in the Server and Partition: Server Management area. On the menu, choose Selected.
- g. Select Activate.
- h. Enter any requested passwords. Go to step [8.j](#).
- i. Right-click on the desired partition name and select the Activate option.
- j. After the keyboard POST indicator displays on the firmware console and before the last POST indicator (speaker) displays, press the numeric 1 key on either the directly attached keyboard or the ASCII terminal to enter the SMS (system management services) menus.
- k. Select Setup Remote IPL (Initial Program Load).
  - l. Enter the client address, server address, gateway address (if applicable), and subnet mask. Exit to the Network Parameters screen.
- m. If the NIM server is set up to allow pinging from the client system, use the ping utility in the RIPL utility to verify that the client system can ping the NIM server. Under the ping utility, choose the network adapter that provides the attachment to the NIM server to do the ping operation. If the ping returns with an OK prompt, the client is prepared to boot from the NIM server. If ping returns with a FAILED prompt, the client cannot proceed with the NIM boot.

**Note:** If the ping fails, check the connections between the server and the NIM server.

- n. Exit the SMS menus completely. The system starts loading packets while doing a bootp from the network.
- o. Go to [Running system verification](#).

To do a one-time boot of the network adapter attached to the NIM server network, do the following:

- a. Exit to the SMS Main screen.
- b. Select Select Boot Options.
- c. Select Install or Boot a Device.
- d. On the Select Device Type screen, select Network.
- e. Set the network parameters for the adapter from which you want to boot.
- f. Exit completely from SMS. The system starts loading packets while doing a bootp from the network.

Follow the instructions on the screen to select the system console.

- ◆ If `Diagnostics Operating Instructions Version x.x.x` displays, standalone diagnostics have loaded successfully.
- ◆ If the operating system login prompt displays, standalone diagnostics did not load. Check the following items:
  - ◇ The network parameters on the client may be incorrect.
  - ◇ Cstate on the NIM server may be incorrect.
  - ◇ Network problems might be preventing you from connecting to the NIM server.

**Note:** If the ping fails, check the connections between the server and the NIM server.

Verify the connections between the server and the NIM server and check the settings and status for the network.

**Note:** If you are unable to load the diagnostics to the point where the DIAGNOSTIC OPERATING INSTRUCTIONS display, go to [Using the HMC to load the standalone diagnostics from CD-ROM](#).

**Running system verification**

When the Diagnostic Operating Instructions display, do the following to run system verification:

1. Press Enter.
2. If the terminal type is requested, you must use the Initialize Terminal option on the Function Selection menu to initialize the operating system before you can continue with the diagnostics.
3. Select the System Verification option on the Diagnostic Mode Selection menu.
4. To run a general checkout of all installed resources, select the All Resource option on the Diagnostic Selection menu. Follow the instructions on the screen to complete the checkout procedure.

To check one particular resource, select that resource on the Diagnostic Selection menu.

The checkout program ends with either of the following results:

- ◆ The Testing Complete screen displays a message stating `No trouble was found.`
- ◆ The A Problem Was Detected On (Time Stamp) menu displays, with either a service request number (SRN) or an error code. Make a note of any codes displayed on the display or operator panel.

**Note:** If you received an error code, record the code and then contact your service support center.

To exit the standalone diagnostics and shutdown the system, refer to [Powering off the system after running standalone diagnostics](#).

To stop diagnostics, do the following:

**Stopping the diagnostics**

1. To exit the diagnostics, press the F3 key (from a defined terminal) or press 99 (from an undefined terminal).
2. If you changed any attributes on your terminal to run the diagnostics, change the settings back to normal.

This completes the system verification.

If the server passed all the diagnostic tests, the verification process is complete and your server is ready to use.

**Powering off the system after running standalone diagnostics**

To power off the system after running AIX standalone diagnostics version 5.3.0.10 or later, you will be asked if you want to halt the system. Answering "yes" to this question will power off the system.

**Note:** It is recommended that when running standalone diagnostics that you use the latest level.

If you are running a version of AIX standalone diagnostics prior to 5.3.0.10, then from the control panel, do the following:

1. Using the up arrow key, select "Option 2".
2. Press the <enter> key until you reach "N".
3. Press the up arrow key to change the "N" to "M" (Manual).
4. Press the <enter> key to go back to the "Option 2" operator panel display.
5. Press the up arrow key to go to "Option 08".
6. Press the <enter> key.
7. Press the up arrow key to go to "Option 08" again.
8. Press the <enter> key. The system powers off.

Pulling the system power plug(s) can be used as a final option to powering off the system after running any version of AIX standalone diagnostics.

## AIX tasks and service aids

The AIX diagnostic package contains programs that are called Tasks.

Tasks can be thought of as performing a specific function on a resource; for example, running diagnostics or performing a service aid on a resource. This chapter describes the tasks available in the AIX diagnostic programs.

### Notes:

1. Many of these programs work on all system model architectures. Some programs are only accessible from online diagnostics in service or concurrent mode, while others may be accessible only from standalone diagnostics.
2. The specific tasks available will be dependent on the hardware attributes or capabilities of the system you are servicing. Not all service aids nor tasks will be available on all systems.
3. If the system is running on a logically partitioned system, the following tasks can be executed only in a partition with service authority:
  - ◆ Configure reboot policy
  - ◆ Configure remote maintenance policy
  - ◆ Configure ring indicate Power On
  - ◆ Configure ring indicate Power-On policy
  - ◆ Update system or service processor flash
  - ◆ Save or restore hardware management policies
  - ◆ Configure scan dump policy

To perform one of these tasks, use the Task Selection option from the FUNCTION SELECTION menu.

After a task is selected, a resource menu may be presented showing all resources supported by the task.

A fast-path method is also available to perform a task by using the diag command and the **-T** flag. By using the fast path, the user can bypass most of the introductory menus to access a particular task. The user is presented with a list of resources available to support the specified task. The fast-path tasks are as follows:

- Certify - Certifies media
- Chkspares - Checks for the availability of spare sectors
- Download - Downloads microcode to an adapter or device
- Disp\_mcode - Displays current level of microcode
- Format - Formats media
- Identify - Identifies the PCI RAID physical disks
- IdentifyRemove - Identifies and removes devices (hot plug)

To run these tasks directly from the command line, specify the resource and other task-unique flags. Use the descriptions in this chapter to understand which flags are needed for a given task.

## Tasks

The following tasks are described in this chapter:

- Add resource to resource list
- AIX shell prompt
- Analyze adapter internal log
- Backup and restore media
- CD-ROM exerciser
- Certify media
- Change hardware vital product data
- Configure dials and LPF keys
- Configure reboot policy (CHRP) on POWER 5 system or later
- Configure remote maintenance policy
- Configure ring indicate power-on policy
- Configure scan dump policy
- Configure surveillance policy
- Create customized configuration diskette
- Delete resource from resource list
- Disk maintenance
- Disk to disk copy
- Diskette exerciser
- Display / alter sector
- Display configuration and resource list
- Display firmware device node information
- Display hardware error report
- Display hardware vital product data
- Display machine check error log
- Display microcode level
- Display multipath I/O (MPIO) device configuration
- Display or change bootlist
- Display or change diagnostic run time options
- Display previous diagnostic results
- Display resource attributes
- Display service hints
- Display software product data
- Display system environmental sensors
- Display test patterns
- Display USB devices
- Download microcode for systems using AIX 5.2.0.30 and later
- DVD RAM media
- Exercise commands
- Fault indicators
- Fibre Channel RAID service aids
- Flash SK-NET FDDI firmware
- Floating point exerciser
- Format media
- Gather system information
- Generic microcode download
- Hardfile attached to PCI SCSI RAID adapter
- Hardfile attached to SCSI adapter (non-RAID)
- Hot plug task
- Identify indicators
- Identify and system attention indicators
- Local area network analyzer
- Log repair action
- Memory exercise
- Microcode installation to adapters and devices
- Microcode installation to disk drive attached to PCI SCSI RAID adapters
- Microcode installation to PCI SCSI RAID adapters
- Microcode installation to SES devices
- Microcode tasks
- Modem configuration
- Optical media
- Periodic diagnostics
- PCI hot plug manager
- PCI SCSI disk identify array manager

- PCI RAID physical disk identify
- Process supplemental media
- RAID hot plug devices
- Reboot/restart policy setup
- Run diagnostics
- Run error log analysis
- Run exercisers
- Save or restore hardware management policies
- SCSI and SCSI RAID hot plug manager
- SCSI bus analyzer
- SCSI hot plug manager
- SCSI RAID physical disk status and vital product data
- SCSD tape drive service aid
- Site specific call in/out setup
- Spare sector availability
- SSA service aid
- Surveillance setup
- System fault indicator
- System identify indicator
- Tape exerciser
- Update disk-based diagnostics
- Update system or service processor flash
- Update and manage system flash
- 7135 RAIDiant Array service aids

### Add resource to resource list

Use this task to add resources back to the resource list.

**Note:** Only resources that were previously detected by the diagnostics and deleted from the diagnostic test list are listed. If no resources are available to be added, then none are listed.

### AIX shell prompt

**Note:** Use this service aid in online service mode only.

This service aid allows access to the AIX command line. To use this service aid, the user must know the root password (when a root password has been established).

**Note:** Do not use this task to install code or to change the configuration of the system. This task is intended to view files, configuration records, and data. Using this service aid to change the system configuration or install code can produce unexplained system problems after exiting the diagnostics.

## Analyze adapter internal log

The PCI RAID adapter has an internal log that logs information about the adapter and the disk drives attached to the adapter. Whenever data is logged in the internal log, the device driver copies the entries to the AIX system error log and clears the internal log.

The analyze adapter internal log service aid analyzes these entries in the AIX system error log. The service aid displays the errors and the associated service actions. Entries that do not require any service actions are ignored.

When running this service aid, a menu is presented to enter the start time, the end time, and the file name. The start time and end time have the following format: *mmddHHMMyy*. (where *mm* is the month (1-12), *dd* is the date (1-31) *HH* is the hour (00-23) *MM* is the minute (00-59), and *yy* is the last two digits of the year (00-99). The file name is the location where the user wants to store the output data.

To invoke the service aid task from the command line, type:

```
diag -c -d devicename -T "adapela -s start date -e end date
```

| Flag                 | Description                                                                        |
|----------------------|------------------------------------------------------------------------------------|
| -c                   | Specifies not console mode.                                                        |
| -d <i>devicename</i> | Specifies the device whose internal log you want to analyze (for example, SCRAID0) |
| -s <i>start date</i> | Specifies all errors after this date are analyzed.                                 |
| -e <i>end date</i>   | Specifies all errors before this date are analyzed.                                |
| -T                   | Specifies the Analyze Adapter Internal Log task                                    |

**Note:** To specify a file name from the command line, use the redirection operator at the end of the command to specify where the output of the command is to be sent, for example `> filename` (where *filename* is the name and location where the user wants to store the output data (for example, /tmp/adaptlog).

## Backup and restore media

This service aid allows verification of backup media and devices. It presents a menu of tape and diskette devices available for testing and prompts for selecting the desired device. It then presents a menu of available backup formats and prompts for selecting the desired format. The supported formats are tar, backup, and cpio. After the device and format are selected, the service aid backs up a known file to the selected device, restores that file to /tmp, and compares the original file to the restored file. The restored file remains in /tmp to allow for visual comparison. All errors are reported.

## Certify media

This task allows the selection of diskette, DVD-RAM media, or hard files to be certified. Normally, this is done under the following conditions:

- To determine the condition of the drive and media
- To verify that the media is error-free after a format service aid has been run on the media

Normally, run Certify if after running diagnostics on a drive and its media, no problem is found, but you suspect that a problem still exists.

Hard files can be connected either to a SCSI adapter (non-RAID) or a PCI SCSI RAID adapter. The usage and criteria for a hard file connected to a non-RAID SCSI adapter are different from those for a hard file connected to a PCI SCSI RAID adapter.

Certify media can be used in the following ways:

- Certify Diskette

This selection enables you to verify the data written on a diskette. When you select this service aid, a menu asks you to select the type of diskette being verified. The program then reads all of the ID and data fields on the diskette one time and displays the total number of bad sectors found.

- Certify DVD-RAM media

This selection reads all of the ID and data fields. It checks for bad data and counts all errors encountered. If an unrecovered data errors occurs, the data on the media should be transferred to another media and the original media should be discarded. If an unrecovered equipment error occurs or recovered errors exceed the threshold value, the original media should be discarded.

The certify service aid displays the following information:

- ◆ Capacity in bytes
- ◆ Number of data errors recovered
- ◆ Number of data errors not recovered
- ◆ Number of equipment check errors
- ◆ Number of equipment checks not recovered

If the drive is reset during a certify operation, the operation is restarted.

If the drive is reset again, the certify operation is terminated, and the user is asked to run diagnostics on the drive.

This task can be run directly from the AIX command line. The command line syntax is: `diag -c -d -T certify`

#### Flag

#### Description

- c No console mode
- d Specifies a device
- T Specifies the certify task

- Certify Hard file Attached to a Non-RAID and PCI-X RAID SCSI Adapter

For pdisks and hdisks, this selection reads all of the ID and data fields on the hard file. If bad-data errors are encountered, the certify operation counts the errors.

If there are non-recovered data errors that do not exceed the threshold value, do one of the following:

- ◆ For hdisk hard files, the hard file must be formatted and then certified again.
- ◆ For pdisk hard files, diagnostics should be run on the parent adapter.

If the non-recovered data errors, recovered data errors, recovered and non-recovered equipment errors exceed the threshold values, the hard file must be replaced.

After the read certify of the disk surface completes for hdisk hard files, the certify operation performs 2000 random-look operations. Errors are also counted during the random-look operations. If a disk timeout occurs before the random looks are finished, the disk needs to be replaced.

The Certify service aid displays the following information:

- ◆ For hdisks:
  - ◇ Drive capacity in megabytes.



- ◇ Number of data errors recovered.
- ◇ Number of data errors not recovered.
- ◇ Number of equipment checks recovered.
- ◇ Number of equipment checks not recovered.
- ◆ For pdisks:
  - ◇ Drive capacity in megabytes.
  - ◇ Number of data errors not recovered.
  - ◇ Number of LBA reassignments
  - ◇ Number of equipment checks not recovered.

This task can be run directly from the AIX command line. The command line syntax is: `diag -c -d deviceName -T "certify"`

#### Flag

#### Description

- c No console mode
- d Specifies a device
- T Specifies the certify task

#### • Certify Hard File Attached to a PCI SCSI RAID Adapter

This selection is used to certify physical disks attached to a PCI SCSI RAID adapter. Certify reads the entire disk and checks for recovered errors, unrecovered errors, and reassigned errors. If these errors exceed the threshold values, the user is prompted to replace the physical disk.

This task can be run directly from the AIX command line. The command line syntax is: `diag -c -d RAIDadapterName -T "certify {-l chID | -A}"`

#### Flag

#### Description

- c No console mode
- d Specifies the RAID adapter to which the disk is attached
- T Specifies the certify task and its parameters
- l Specifies physical disk channel/ID (for example: -l 27)
- A All disks

## Change hardware vital product data

Use this service aid to display the display/alter VPD selection menu. The menu lists all resources installed on the system. When a resource is selected, a menu displays that lists all the VPD for that resource.

**Note:** The user cannot alter the VPD for a specific resource unless the VPD is not machine-readable.

## Configure dials and LPF keys

**Note:** The dials and LPF keys service aid is not supported in standalone mode (CD-ROM and NIM) on systems with 32 MB or less memory. If you have problems in standalone mode, use the hardfile-based diagnostics.

This service aid provides a tool for configuring and removing dials and LPF keys to the asynchronous system ports.

This selection invokes the SMIT utility to allow dials and LPF keys configuration. A TTY must be in the available state on the async port before the dials and LPF keys can be configured on the port. The task allows an async adapter to be configured, then a TTY port defined on the adapter. dials and LPF keys can then be defined on the port.

Before configuring dials or LPF keys on a system port, you must remove all defined TTYs. To determine if there are any defined TTYs, select List All Defined TTYs. Once all defined TTYs have been removed, then add a new TTY and configure the dials or LPF keys.

### Configure reboot policy (CHRP) on POWER5 systems or later

This service aid controls how the system tries to recover when power is restored after a power outage.

Use this service aid to display and change the following settings for the reboot policy.

#### Enable platform automatic power restart

When enabled, "Platform auto power restart" allows the platform firmware to restart a system after power is restored following a power outage. If the system is partitioned, each partition that was running when the power outage occurred will be restarted as indicated by that partition's setting of the system management (SMIT) option: "Automatically reboot operating system after a crash".

This service aid may be accessed directly from the command line, by entering:

```
/usr/lpp/diagnostics/bin/uspchrp -b
```

The parameter setting may be read and set directly from the command line. To read the parameter, use the command:

```
/usr/lpp/diagnostics/bin/uspchrp -q platform-auto-power-restart
```

To set the parameter, use the command:

```
/usr/lpp/diagnostics/bin/uspchrp -e platform-auto-power-restart=0|1
```

where:

1 = Enable Platform Automatic Power Restart  
0 = Disables Platform Automatic Power Restart

The Platform Boot Speed system parameter can be read or set from the command line only. To read the Platform Boot Speed system parameter, use the command: `/usr/lpp/diagnostics/bin/uspchrp -q PlatformBootSpeed`

To set the Platform Boot Speed system parameter, use the command:

```
/usr/lpp/diagnostics/bin/uspchrp -e PlatformBootSpeed=fast|slow.
```

With a fast platform speed, the platform firmware will perform a minimal set of hardware tests before loading the operating system. With a slow platform speed, the platform firmware will perform a comprehensive set of

hardware tests before loading the operating system.

For the command:

```
/usr/lpp/diagnostics/bin/uspchrp -q <variable name> | -e <variable name>=value
```

The return codes are:

0 = command successful

1 = command not successful

### Configure remote maintenance policy

The remote maintenance policy includes modem configurations and phone numbers to use for remote maintenance support.

Use this service aid to display and change the following settings for the remote maintenance policy.

**Note:** Because of system capability, some of the following settings might not be displayed by this service aid.

- Configuration file for modem on system port 1 (S1)

Configuration file for modem on system port 2 (S2).

Enter the name of a modem configuration file to load on either S1 or S2. The modem configuration files are located in the directory `/usr/share/modems`. If a modem file is already loaded, it is indicated by `Modem file currently loaded`.

- Modem file currently loaded on S1

Modem file currently loaded on S2

This is the name of the file that is currently loaded on system port 1 or serial port 2.

**Note:** These settings are only shown when a modem file is loaded for a system port.

- Call In Authorized on S1 (on/off)

Call In Authorized on S2 (on/off)

Call in allows the service processor to receive a call from a remote terminal.

- Call Out Authorized on S1 (on/off)

Call Out Authorized on S2 (on/off)

Call out allows the service processor to place calls for maintenance.

- S1 Line Speed

S2 Line Speed

A list of line speeds is available by using `List` on the screen.

- Service Center Phone Number

This is the number of the service center computer. The service center usually includes a computer that takes calls from systems with call-out capability. This computer is referred to as "the catcher." The catcher expects messages in a specific format to which the service processor conforms. For more information about the format and catcher computers, refer to the README file in the AIX `/usr/samples/syscatch` directory. Contact the service provider for the correct telephone number to

enter here.

- Customer Administration Center Phone Number

This is the number of the system administration center computer (catcher) that receives problem calls from systems. Contact the system administrator for the correct telephone number to enter here.

- Digital Pager Phone Number In Event of Emergency

This is the number for a pager carried by someone who responds to problem calls from your system.

- Customer Voice Phone Number

This is the number for a telephone near the system, or answered by someone responsible for the system. This is the telephone number left on the pager for callback.

- Customer System Phone Number

This is the number to which your system's modem is connected. The service or administration center representatives need this number to make direct contact with your system for problem investigation.

This is also referred to as the `call in phone number`.

- Customer Account Number

This number is available for service providers to use for record-keeping and billing.

- Call Out Policy Numbers to call if failure

This is set to either first or all. If the call-out policy is set to first, call out stops at the first successful call to one of the following numbers in the order listed:

1. Service Center
2. Customer Administration Center
3. Pager

If call out policy is set to all, call-out attempts to call all of the following numbers in the order listed:

1. Service Center
2. Customer Administration Center
3. Pager

- Remote Timeout, in seconds Remote Latency, in seconds

These settings are functions of the service provider's catcher computer.

- Number of Retries While Busy

This is the number of times the system should retry calls that resulted in busy signals.

- System Name (System Administrator Aid)

This is the name given to the system and is used when reporting problem messages.

**Note:** Knowing the system name aids the support team in quickly identifying the location, configuration, history, and so on of your system.

You can access this service aid directly from the AIX command line by typing:

```
/usr/lpp/diagnostics/bin/uspchrp -m
```

## Configure ring indicate power-on policy

This service aid allows the user to power-on a system by telephone from a remote location. If the system is powered off, and ring indicate power-on is enabled, the system powers on at a predetermined number of rings. If the system is already on, no action is taken. In either case, the telephone call is not answered, and the caller receives no feedback that the system has powered on.

Use this service aid to display and change the following settings for the ring indicate power-on policy:

Because of system capability, some of the following settings might not be displayed by this service aid.

- Power On Via Ring Indicate (on/off)
- Number of Rings Before Power On

You can access this service aid directly from the AIX command line by typing:

```
/usr/lpp/diagnostics/bin/uspchrp -r
```

### Configure scan dump policy

Configure scan dump policy allows the user to set or view the scan dump policy (scan dump control and size) in NVRAM. Scan dump data is a set of chip data that the service processor gathers after a system malfunction. It consists of chip scan rings, chip trace arrays, and scan COM (SCOM) registers. This data is stored in the scan-log partition of the system's nonvolatile random access memory (NVRAM).

Use this service aid to display and change the following settings for the scan dump policy at run time:

- Scan Dump Control (how often the dump is taken)
- Scan Dump Size (size and content of the dump)

The Scan Dump Control (SDC) settings are as follows:

- As needed: This setting allows the platform firmware to determine whether a scan dump is performed. This is the default setting for the dump policy.
- Always: This setting overrides the firmware recommendations and always performs a dump after a system failure.

The Scan Dump Size (SDS) settings are as follows:

- As Requested - Dump content is determined by the platform firmware.
- Minimum - Dump content collected provides the minimum debug information, enabling the platform to reboot as quickly as possible.
- Optimum - Dump content collected provides a moderate amount of debug information.
- Complete - Dump data provides the most complete error coverage at the expense of reboot speed.

You can access this service aid directly from the AIX command line by typing:

```
/usr/lpp/diagnostics/bin/uspchrp -d
```

## Surveillance setup

**Note:** Surveillance is only supported for systems running in full machine partition.

This selection allows you to display and change the NVRAM settings for the surveillance capability of the service processor.

The settings allow you to:

- Enable or disable surveillance
- Set the surveillance time interval, in minutes
- Set the surveillance delay, in minutes

The current settings are read from NVRAM and displayed on the screen. Any changes made to the data shown are written to NVRAM.

## Modem configuration

Use this selection when setting the NVRAM for a modem attached to any of the service processor's system ports. The user inputs the file name of a modem configuration file and the system port number. The formatted modem configuration file is read, converted for NVRAM, and then loaded into NVRAM.

## Call In/Out Setup

This selection allows the user to display and change the NVRAM settings for the call in/call out capability of the service processor.

The settings allow the user to:

- Enable or disable call in on either system port
- Enable or disable call out on either system port
- Set the line speed on either system port

## Site specific call in/out setup

This selection allows you to display and change the NVRAM settings that are site-specific for the call-in or call-out capability of the service processor.

The site-specific NVRAM settings allow you to set the following:

- Phone number for the service center
- Phone number for the customer administration center
- Phone number for a digital pager
- Phone number for the customer system to call in
- Phone number for the customer voice phone
- Customer account number
- Call-out policy
- Remote timeout value
- Remote latency value
- Number of retries while busy
- System name

The current settings are read from NVRAM and displayed on the screen. Any changes made to the data shown are written to NVRAM.

## Reboot/restart policy setup

This selection controls how the system tries to recover from a system crash.

Use this service aid to display and change the following settings for the reboot policy setup.

- Maximum number of reboot attempts  
Enter a number that is 0 or greater.

**Note:** A value of 0 indicates "do not attempt to reboot" to a crashed system.

This number is the maximum number of consecutive attempts allowed to reboot the system. The term *reboot*, when used in context of this service aid, describes the system hardware being brought back up from scratch. Examples would be a system reset or turning on the power.

When the maximum number of reboot attempts is exceeded, the system calls out if that function has been enabled.

When the reboot process completes successfully, the reboot-attempts count is reset to 0, and a restart begins. The term *restart*, when used in context of this service aid, describes the operating system activation process. Restart always follows a successful reboot.

When a restart fails, and a restart policy is enabled, the system attempts to reboot for the maximum number of reboot attempts.

- Enable Restart Policy (1=Yes, 0=No)

When the service processor detects operating system inactivity, an enabled "restart policy" causes a system reset, and the reboot process begins.

- Call-Out Before Restart (on/off)

When enabled, "call-out before restart" allows the system to call out (on a system port that is enabled for call-out) when an operating system restart is initiated. Such call-outs can be valuable if the number becomes excessive, thus signalling bigger problems.

- Enable Unattended Start Mode (1=Yes, 0=No)

When enabled, "unattended start mode" allows the system to recover from the loss of ac power.

If the system was powered-on when the ac loss occurred, the system reboots when power is restored. If the system was powered-off when the ac loss occurred, the system remains off when power is restored.

## Configure surveillance policy

**Note:** This service aid is supported only for systems running in full machine partition.

This service aid monitors the system for hang conditions; that is, hardware or software failures that cause operating system inactivity. When enabled, and surveillance detects operating system inactivity, a call is placed to report the failure.

Use this service aid to display and change the following settings for the surveillance policy:

**Note:** Because of system capability, some of the following settings might not be displayed by this service aid:

- Surveillance (on/off)
- Surveillance Time Interval - This is the maximum time between heartbeats from the operating system.
- Surveillance Time Delay - This is the time to delay between when the operating system is in control and when to begin operating system surveillance.
- Changes are to Take Effect Immediately - Set this to yes if the changes made to the settings in this menu are to take place immediately. Otherwise, the changes take effect beginning with the next system boot.

You can access this service aid directly from the AIX command line by typing:

```
/usr/lpp/diagnostics/bin/uspchrp -s
```

### Create customized configuration diskette

This selection invokes the Diagnostic Package Utility Service Aid, which allows the user to create a standalone diagnostic package configuration diskette.

The standalone diagnostic package configuration diskette allows the following to be changed from the console:

- Default refresh rate for a low function terminal (LFT)

The refresh rate used by the standalone diagnostic package is 60 Hz. If the display's refresh rate is 77 Hz, set the refresh rate to 77.

- Different async terminal console

You can create a console configuration file that allows a terminal attached to any RS232 or RS422 adapter to be selected as a console device. The default device is an RS232 TTY device attached to the first standard system port (S1).

### Delete resource from resource list

Use this task to delete resources from the resource list.

**Note:** Only resources that were previously detected by the diagnostics and have not been deleted from the diagnostic test list are listed. If no resources are available to be deleted, then none are listed.

### Disk maintenance

This service aid provides the following options for the fixed-disk maintenance:

- Disk to Disk Copy
- Display/Alter Sector

### Disk to disk copy

#### Notes:

1. This service aid cannot be used to update a drive of a different size. The service aid only supports copying from a SCSI drive to another SCSI drive of the same size.



2. Use the `migratepv` command when copying the contents to other disk drive types. This command also works when copying SCSI disk drives or when copying to a SCSI disk drive that is not the same size. Refer to *System Management Guide: Operating System and Devices* for a procedure on to migrate the contents of a physical volume.

This publication is located on the *AIX documentation* CD. The documentation information is made accessible by loading the documentation CD onto the hard disk or by mounting the CD in the CD-ROM drive.

This selection allows you to recover data from an old drive when replacing it with a new drive. The service aid recovers all logical volume manager (LVM) software-reassigned blocks. To prevent corrupted data from being copied to the new drive, the service aid stops if an unrecoverable read error is detected. To help prevent possible problems with the new drive, the service aid stops if the number of bad blocks being reassigned reaches a threshold.

To use this service aid, both the old and new disks must be installed in or attached to the system with unique SCSI addresses. This requires that the new disk drives SCSI address must be set to an address that is not currently in use and the drive be installed in an empty location. If there are no empty locations, then one of the other drives must be removed. When the copy is complete, only one drive can remain installed. Either remove the target drive to return to the original configuration, or perform the following procedure to complete the replacement of the old drive with the new drive:

1. Remove both drives.
2. Set the SCSI address of the new drive to the SCSI address of the old drive.
3. Install the new drive in the old drive's location.
4. Install any other drives (that were removed) into their original location.

To prevent problems that can occur when running this service aid from disk, it is suggested that this service aid be run, when possible, from the diagnostics that are loaded from removable media.

## Display/alter sector

**Note:** Use caution when you use this service aid because inappropriate modification to some disk sectors can result in the total loss of all data on the disk.

This selection allows the user to display and alter information on a disk sector. Sectors are addressed by their decimal sector number. Data is displayed both in hex and in ASCII. To prevent corrupted data from being incorrectly corrected, the service aid does not display information that cannot be read correctly.

## Display configuration and resource list

If a device is not included in the test list or if you think a diagnostic package for a device is not loaded, check by using the display configuration and resource list task. If the device you want to test has a plus (+) sign or a minus (-) sign preceding its name, the diagnostic package is loaded. If the device has an asterisk (\*) preceding its name, the diagnostic package for the device is not loaded or is not available.

This service aid displays the item header only for all installed resources. Use this service aid when there is no need to see the vital product data (VPD). (No VPD is displayed.)

### Display firmware device node information

This task displays the firmware device node information. This service aid is intended to gather more information about individual or particular devices on the system. The format of the output data may differ depending on which level of the AIX operating system is installed.

### Display hardware error report

This service aid uses the `errpt` command to view the hardware error log.

The display error summary and display error detail selections provide the same type of report as the `errpt` command. The display error analysis summary and display error analysis detail selections provide additional analysis.

### Display hardware vital product data

This service aid displays all installed resources, along with any VPD for those resources. Use this service aid when you want to look at the VPD for a specific resource.

### Display machine check error log

**Note:** The display machine check error log service aid is available only on standalone diagnostics.

When a machine check occurs, information is collected and logged in an NVRAM error log before the system unit shuts down. This information is logged in the AIX error log and cleared from NVRAM when the system is rebooted from the hard disk, LAN, or standalone media. When booting from standalone diagnostics, this service aid converts the logged information into a readable format that can be used to isolate the problem. When booting from the hard disk or LAN, the information can be viewed from the AIX error log using the hardware error report service aid. In either case, the information is analyzed when the `sysplanar0` diagnostics are running in problem determination mode.

### Display microcode level

**Note:** Note: In AIX diagnostics versions 5.2.0.75, 5.3.0.30, and later, display microcode level is a subtask that can be accessed after selecting Microcode Tasks.

This task provides a way to display microcode on a device or adapter. When the sys0 resource is selected, the task displays the levels of both the system firmware and service processor firmware. sys0 may not be available in all cases.

You can display the current level of the microcode on an adapter, the system, or a device by using the AIX `diag` command. See the following command syntax: `diag -c -d device -T "disp_mcode"`

### Flag

|    | Description                                                  |
|----|--------------------------------------------------------------|
| -c | No console mode.                                             |
| -d | Used to specify a device.                                    |
| -T | Use the <code>disp_mcode</code> option to display microcode. |

The AIX `lsmcode` command serves as a command line interface to the display microcode level task. For information on the `lsmcode` command, refer to the *AIX Commands Reference* manual.

## Display MultiPath I/O (MPIO) device configuration

This service aid displays the status of MPIO devices and their connections to their parent devices.

This service aid is capable of sending SCSI commands on each available path regardless of the default MPIO path algorithm. Therefore, it is useful for testing the unused path for integrity.

Run this service aid if it is suspected that there is a problem with the path between MPIO devices and their parent devices.

This service aid is capable of:

- Listing MPIO devices
- Listing the parents of MPIO devices
- Displaying the status and location of specified MPIO devices
- Displaying the hierarchy of MPIO adapters and devices.

If there are no devices with multiple paths, this service aid will not be shown on the Task Selection menu.

Access this service aid directly from the AIX command line by typing:

```
/usr/lpp/diagnostics/bin/umpio
```

## Display or change bootlist

This service aid allows the bootlist to be displayed, altered, or erased.

The system attempts to perform an IPL from the first device in the list. If the device is not a valid IPL device or if the IPL fails, the system proceeds in turn to the other devices in the list to attempt an IPL.

## Display or change diagnostic run-time options

The display or change diagnostic run-time options task allows the diagnostic run-time options to be set.

**Note:** The run-time options are used only when selecting the run diagnostic task.

The run-time options are:

- Display Diagnostic Mode Selection Menus

This option allows the user to turn on or off displaying the DIAGNOSTIC MODE SELECTION MENU (the default is on).

- Run Tests Multiple Times

This option allows the user to turn on or off, or specify a loop count, for diagnostic loop mode (the default is off).

**Note:** This option is only displayed when you run the online diagnostics in service mode.

- Include Advanced Diagnostics

This option allows the user to turn on or off including the advanced diagnostics (the default is off).

- Include Error Log Analysis (not available in diagnostics 5.2.0 or later)

This option allows the user to turn on or off including the error log analysis (ELA) (the default is off).

- Number of Days Used to Search Error Log

This option allows the user to select the number of days for which to search the AIX error log for errors when running the error log analysis. The default is seven days, but it can be changed from one to sixty days.

- Display Progress Indicators

This option allows the user to turn on or off the progress indicators when running the diagnostic applications. The progress indicators, in a box at the bottom of the screen, indicate that the test is being run (the default is on).

- Diagnostic Event Logging

This option allows the user to turn on or off logging information to the diagnostic event log (the default is on).

- Diagnostic Event Log File Size

This option allows the user to select the maximum size of the diagnostic event log. The default size for the diagnostic event log is 100 KB. The size can be increased in 100 KB increments to a maximum of 1 MB.

Use the `diaggetrto` command to display one or more diagnostic run-time options. Use the following AIX command syntax:

```
/usr/lpp/diagnostics/bin/diaggetrto -a -d -l -m -n -p -s
```

Use the `diagsetrto` command to change one or more diagnostic run-time options. Use the following AIX command syntax:

```
/usr/lpp/diagnostics/bin/diagsetrto -a on|off -d on|off -l size  
-m on|off -n days -p on|off
```

Flag descriptions for the `diaggetrto` and `diagsetrto` commands are as follows:

| Flag | Description |
|------|-------------|
|------|-------------|

|    |  |
|----|--|
| -a |  |
|----|--|

- d Displays or changes the value of the include advanced diagnostics option.
- l Displays or changes the value of the diagnostic event logging option.
- l Displays or changes the value of the diagnostic event log file size. Allowable size are between 100K and 1000K in increments of 100K. The size may never be decreased.
- m Displays or changes the value of the display diagnostic mode selection menu option.
- n Displays or changes the value of the number of days used to search the error log option. Allowable values are between 1 and 60 days. 7 days is the default.
- p Displays or changes the value of the display progress indicators option.
- s Displays all of the diagnostic run-time options.

### Display previous diagnostic results

**Note:** This service aid is not available when you load the diagnostics from a source other than a hard disk drive or a network.

This service aid allows a service representative to display results from a previous diagnostic session. When the display previous diagnostic results option is selected, the user can view up to 25 no trouble found (NTF) and service request number (SRN) results.

This service aid displays diagnostic event log information. You can display the diagnostic event log in a short version or a long version. The diagnostic event log contains information about events logged by a diagnostic session.

This service aid displays the information in reverse chronological order.

This information is not from the AIX operating system error log. This information is stored in the /var/adm/ras directory.

You can run the command from the AIX command line by typing: /usr/lpp/diagnostics/bin/diagrpt  
-o ? -s mmddyy ? -a ? -r

#### Flag

| Flag             | Description                                                                                 |
|------------------|---------------------------------------------------------------------------------------------|
| -o               | Displays the last diagnostic results file stored in the /etc/lpp/diagnostics/data directory |
| -s <i>mmddyy</i> | Displays all diagnostic result files logged since the date specified                        |
| -a               | Displays the long version of the diagnostic event log                                       |
| -r               | Displays the short version of the diagnostic event log                                      |

### Display resource attributes

This task displays the customized device attributes associated with a selected resource. This task is similar to running the lsattr -E -l resource command.

## Display service hints

This service aid reads and displays the information in the CEReadme file from the diagnostics media. This file contains information that is not contained in the publications for this version of the diagnostics. The file also contains information about using this particular version of diagnostics.

## Display software product data

This task uses SMIT to display information about the installed software and provides the following functions:

- List Installed Software
- List Applied but Not Committed Software Updates
- Show Software Installation History
- Show Fix (APAR) Installation Status
- List Fileset Requisites
- List Fileset Dependents
- List Files Included in a Fileset
- List File Owner by Fileset

## Display system environmental sensors

This service aid displays the environmental sensor information for the system. The information displayed is the sensor name, physical location code, literal value of the sensor status, and the literal value of the sensor reading.

The sensor status can be any one of the following:

- Normal - The sensor reading is within the normal operating range.
- Critical high - The sensor reading indicates a serious problem with the device. Run diagnostics on `sysplanar0` to determine what repair action is needed.
- Critical low - The sensor reading indicates a serious problem with the device. Run diagnostics on `sysplanar0` to determine what repair action is needed.
- Warning high - The sensor reading indicates a problem with the device. This could become a critical problem if action is not taken. Run diagnostics on `sysplanar0` to determine what repair action is needed.
- Warning low - The sensor reading indicates a problem with the device. This could become a critical problem if action is not taken. Run diagnostics on `sysplanar0` to determine what repair action is needed.
- Hardware error - The sensor could not be read because of a hardware error. Run diagnostics on `sysplanar0` in problem-determination mode to determine what repair action is needed.
- Hardware busy - The system has repeatedly returned a busy indication, and a reading is not available. Try the service aid again. If the problem continues, run diagnostics on `sysplanar0` in problem-determination mode to determine what repair action is needed.

This service aid can also be run as a command. You can use the command to list the sensors and their values in a text format, list the sensors and their values in numerical format, or a specific sensor can be queried to return either the sensor status or sensor value.

Run the command by entering one of the following: `/usr/lpp/diagnostics/bin/uesensor -l | -a /usr/lpp/diagnostics/bin/uesensor -t token -i index -v`

| Flag | Description |
|------|-------------|
|------|-------------|

|    |  |
|----|--|
| -l |  |
|----|--|

List the sensors and their values in a text format.

-a

List the sensors and their values in a numerical format. For each sensor, the numerical values are displayed as: *token index status measured value location code*

-t *token*

Specifies the sensor token to query.

-i *index*

Specifies the sensor index to query.

-v

Indicates to return the sensor measured value. The sensor status is returned by default.

## Examples

The following are examples from this command:

1. Display a list of the environmental sensors: `/usr/lpp/diagnostics/bin/uesensor -l`

```
Sensor = Fan Speed
Status = Normal
Value = 2436 RPM
Location Code = F1
Sensor = Power Supply
Status = Normal
Value = Present and operational
Location Code = V1
Sensor = Power Supply
Status = Critical low
Value = Present and not operational
Location Code = V2
```

2. Display a list of the environmental sensors in a numerical list:

```
/usr/lpp/diagnostics/bin/uesensor -a
```

```
3 0 11 87 P1
9001 0 11 2345 F1
9004 0 11 2 V1
9004 1 9 2 V2
```

3. Return the status of sensor 9004, index 1: `/usr/lpp/diagnostics/bin/uesensor -t 9004 -i 1`

```
9
```

4. Return the value of sensor 9004, index 1: `/usr/lpp/diagnostics/bin/uesensor -t 9004 -i 1 -v`

```
2
```

## Display test patterns

This service aid provides a means of adjusting system display units by providing test patterns that can be displayed. The user works through a series of menus to select the display type and test pattern. After the selections are made, the test pattern displays.

## Display USB devices

The following are the main functions of this service aid:

- Display a list of USB controllers on an adapter.
- Display a list of USB devices that are connected to the selected controller.

To run the USB devices service aid, go to the diagnostics "TASKS SELECTION" menu, select "*Display USB Devices*". From the controller list that displayed on the screen, select one of the items that begins with "OHCDX", where "X" is a number. A list of devices attached to the controller displays.

## Download microcode for systems using AIX 5.2.0.30 and later

**Note:** In AIX diagnostics versions 5.2.0.75, 5.3.0.30, and later, "Download microcode for systems using AIX 5.2.0.30 and later" is a subtask that can be accessed after selecting "Microcode Tasks".

This service aid provides a way to copy microcode to an adapter or device. The service aid presents a list of adapters and devices that use microcode. After the adapter or device is selected, the service aid provides menus to guide you in checking the current level and installing the needed microcode.

This task can be run directly from the AIX command line. Most adapters and devices use a common syntax as identified in the "Microcode Installation to Adapters and Devices" section. Information for adapters and devices that do not use the common syntax can be found following this section.

## Microcode installation to adapters and devices

For many adapters and devices, microcode installation occurs and becomes effective while the adapters and devices are in use. It is recommended that a current backup be available and the installation be scheduled during a non-peak production period.

### Notes:

1. If the source is `/etc/microcode`, the image must be stored in the `/etc/microcode` directory on the system. If the system is booted from a NIM server, the image must be stored in the `usr/lib/microcode` directory of the SPOT the client is booted from.
2. If the source is CD (cdX), the CD must be in ISO 9660 format. There are no restrictions as to what directory in which to store the image.
3. If the source is diskette (fdX), the diskette must be in backup format and the image stored in the `/etc/microcode` directory.

The following is the common syntax command:  
`diag -c -d <device> -T "download -s {/etc/microcode|<source>} -l {latest|previous} -f"`

### Flag

#### Description

- c  
No console mode. Run without user interaction.
- d <device>  
Run the task on the device or adapter specified.
- T download  
Install microcode.
- s `/etc/microcode`  
Microcode image is in `/etc/microcode`. This is the default.
- s <source>  
Microcode image is on specified source. For example, fd0, cd0.
- l latest



- Install latest level of microcode. This is the default.
- l previous  
Install previous level of microcode.
- f  
Install microcode even if the current level is not on the source.

## Microcode installation to a SES device

### Notes:

1. If the source is /etc/microcode, the image must be stored in the /etc/microcode directory on the system. If the system is booted from a NIM server, the image must be stored in the usr/lib/microcode directory of the SPOT the client is booted from.
2. If the source is CD (cdX), the CD must be in ISO 9660 format. There are no restrictions as to what directory to store the image.
3. If the source is diskette (fdX), the diskette must be in backup format and the image stored in the /etc/microcode directory.

The following is the common syntax command:  
`diag -c -d <device> -T "download -s {/etc/microcode|<source>}"`

### Flag

| Flag              | Description                                                    |
|-------------------|----------------------------------------------------------------|
| -c                | No console mode. Run without user interaction.                 |
| -d <device>       | Run the task on the device or adapter specified.               |
| -T download       | Install microcode.                                             |
| -s /etc/microcode | Microcode image is in /etc/microcode.                          |
| -s <source>       | Microcode image is on specified source. For example, fd0, cd0. |

## Microcode installation to PCI SCSI RAID adapters

PCI SCSI RAID adapters that support this type of installation are:

- Type 4-H, PCI SCSI-2 Fast/Wide RAID Adapter (Feature Code 2493)
- Type 4-T, PCI 3-Channel Ultra2 SCSI RAID Adapter (Feature Code 2494)
- Type 4-X, PCI 4-Channel Ultra3 SCSI RAID Adapter (Feature Code 2498)

### Notes:

1. If the image is on the hard drive, it must be stored in the /etc/microcode directory on the system. If the system is booted from a NIM server, the image must be stored in the usr/lib/microcode directory of the SPOT the client is booted from.
2. If the image is on a diskette, the diskette must be in backup format and the image stored in the /etc/microcode directory.

syntax: diag -c -d <RAIDadapterName> -T "download -B-D-P"

| Flag                 | Description                                                       |
|----------------------|-------------------------------------------------------------------|
| -c                   | No console mode. Run without user interaction.                    |
| -d <RAIDadapterName> | Run the task on the RAID adapter specified.                       |
| -T download          | Install microcode.                                                |
| -B                   | Install boot block microcode. Default is functional microcode.    |
| -D                   | Microcode image is on diskette. Default is /etc/microcode.        |
| -P                   | Install the previous level of microcode. Default is latest level. |

### Microcode installation to disk drive attached to PCI SCSI RAID adapters

Microcode for a disk drive attached to a PCI SCSI RAID adapter is installed through the adapter to the drive. PCI SCSI RAID adapters that support this type of installation are:

- Type 4-H, PCI SCSI-2 Fast/Wide RAID Adapter (Feature Code 2493)
- Type 4-T, PCI 3-Channel Ultra2 SCSI RAID Adapter (Feature Code 2494)
- Type 4-X, PCI 4-Channel Ultra3 SCSI RAID Adapter (Feature Code 2498)

### Notes:

1. If the image is on the hard drive, it must be stored in the /etc/microcode directory on the system. If the system is booted from a NIM server, the image must be stored in the usr/lib/microcode directory of the SPOT the client is booted from.
2. If the image is on a diskette, the diskette must be in backup format and the image stored in the /etc/microcode directory.

syntax:diag -c -d <RAIDadapterName> -T "download {-l <chID> | -A} -D-P"

| Flag                 | Description                                                       |
|----------------------|-------------------------------------------------------------------|
| -c                   | No console mode. Run without user interaction.                    |
| -d <RAIDadapterName> | Name of the RAID adapter the disk is attached to.                 |
| -T download          | Install microcode.                                                |
| -l                   | Physical disk channel/ID of RAID disk drive (example: 27).        |
| -A                   | All disk drives attached to specified RAID adapter.               |
| -D                   | Microcode image is on diskette. Default is /etc/microcode.        |
| -P                   | Install the previous level of microcode. Default is latest level. |

## Fault indicators

This task is only available through a command line interface. It is not available from the diagnostic menu nor from ESCALA PL Series standalone diagnostics.

The fault indicators are used to identify a fault with the system. These indicators may be set automatically by hardware, firmware, or diagnostics when a fault is detected in the system.

The System Attention Indicator is turned off when a Log Repair Action is performed. All other Fault Indicators are turned off when the failing unit is repaired or replaced. After a serviceable event is complete, do a System Verification to verify the fix. Also, do a Log Repair Action if the test on the resource was good, and that resource had an entry in the error log.

For additional information concerning the use of these indicators, refer to the system guide.

**Note:** The AIX command does not allow you to set the fault indicators to the fault state.

Use the following command syntax:

```
/usr/lpp/diagnostics/bin/usysfault -s normal -l location code | -d device name
/usr/lpp/diagnostics/bin/usysfault -t
```

| Flag                           | Description                                                                   |
|--------------------------------|-------------------------------------------------------------------------------|
| <b>-s</b> <i>normal</i>        | Sets the fault indicator to the normal state.                                 |
| <b>-l</b> <i>location code</i> | Identifies the resource by physical location code.                            |
| <b>-d</b> <i>device name</i>   | Identifies the resource by device name.                                       |
| <b>-t</b>                      | Displays a list of all supported fault indicators by physical location codes. |

When the command is used without the -s flag, the current state of the indicator is displayed as normal or fault.

When the command is used without the -l or -d flag, the System Attention Indicator is used.

Use the -l or -d flags only in systems that have more than one fault indicator.

**Note:** See also the [Identify and system attention indicators](#).

## Fibre channel RAID service aids

The fibre channel RAID service aids contain the following functions:

### Certify LUN

This selection reads and checks each block of data in the logical unit number (LUN). If excessive errors are encountered, the user is notified.

You can run this task from the AIX command line. Use the following fast-path command:

```
diag -T "certify"
```

### Certify spare physical disk

This selection allows the user to certify (check integrity of the data) drives that are designated as spares.

You can run this task from the AIX command line. Use the following fast-path command:

```
diag -T "certify"
```

#### Format physical disk

This selection is used to format a selected disk drive.

You can run this task from the AIX command line. Use the following fast-path command:

```
diag -T "format"
```

#### Array controller microcode download

This selection allows the microcode on the fibre channel RAID controller to be updated when required.

You can run this task from the AIX command line. Use the following fast-path command:

```
diag -T "download"
```

#### Physical disk microcode download

This selection is used to update the microcode on any of the disk drives in the array.

You can run this task from the AIX command line. Use the following fast-path command:

```
diag -T "download"
```

#### Update EEPROM

This selection is used to update the contents of the electronically erasable programmable read-only memory (EEPROM) on a selected controller.

#### Replace controller

Use this selection when it is necessary to replace a controller in the array.

### Flash SK-NET FDDI firmware

This task allows the flash firmware on the SysConnect SK-NET FDDI adapter to be updated.

### Format media

This task allows the selection of diskettes, hardfiles, or optical media to be formatted. Each selection is described below.

#### Hardfile attached to SCSI adapter (non-RAID)

- Hardfile Format

Writes all of the disk. The pattern written on the disk is device-dependent; for example some drives may write all 0s, while some may write the hexadecimal number 5F. No bad block reassignment occurs

- Hardfile Format and Certify

Performs the same function as hardfile format. After the format is completed, Certify is run. Certify then reassigns all bad blocks encountered.

- Hardfile Erase Disk

This option can be used to overwrite (remove) all data currently stored in user-accessible blocks of the disk. The derase disk option writes one or more patterns to the disk. An additional option allows data in a selectable block to be read and displayed on the system console.

To use the erase disk option, specify the number (0-3) of patterns to be written. The patterns are written serially; that is, the first pattern is written to all blocks. The next pattern is written to all blocks, overlaying the previous pattern. A random pattern is written by selecting the Write Random Pattern? option.

**Note:** The erase disk service aid has not been certified as meeting the Department of Defense or any other organization's security guidelines.

To overwrite the data on the drive, use the following steps :

1. Select Erase Disk.
2. Do a format without certify.
3. Select Erase Disk to run it a second time.

For a newly installed drive, you can ensure that all blocks on the drive are overwritten with your pattern by using the following procedure:

1. Format the drive.
2. Check the defect MAP by running the erase disk option.

**Note:** If you use the format and certify option, there may be some blocks which get placed into the grown defect MAP.

3. If there are bad blocks in the defect MAP, record the information presented and ensure that this information is kept with the drive. This data is used later when the drive is to be overwritten.
4. Use the drive as you would normally.
5. When the drive is no longer needed and is to be erased, run the same version of the erase disk option which was used in step 2.

**Note:** Using the same version of the service aid is only critical if any bad blocks were found in step 3.

6. Compare the bad blocks which were recorded for the drive in step 3 with those that now appear in the grown defect MAP.

**Note:** If there are differences between the saved data and the newly obtained data, all sectors on this drive cannot be overwritten. The new bad blocks are not overwritten.

7. If the bad block list is the same, continue running the service aid to overwrite the disk with the chosen pattern(s).

This task can be run directly from the AIX command line. The command syntax is: `diag -c -d deviceName -T "format -s* fmtcert | erase -a {read | write} -P {comma separated list of patterns} -F*`

**Note:** The following flags are not available for pdisk devices.

| Flag    | Description                                                                                                                                                                                                                                                                             |
|---------|-----------------------------------------------------------------------------------------------------------------------------------------------------------------------------------------------------------------------------------------------------------------------------------------|
| fmtcert | Formats and certifies the disk.                                                                                                                                                                                                                                                         |
| erase   | Overwrites the data on the disk.                                                                                                                                                                                                                                                        |
| *       | Available in no-console mode only.                                                                                                                                                                                                                                                      |
| -F      | Forces the disk erasure even if all blocks cannot be erased because of errors accessing the grown defect map.                                                                                                                                                                           |
| -P      | Comma separated list of hexadecimal patterns to be written to the drive serially. Up to eight patterns can be specified using a single command. The patterns must be 1, 2, or 4 bytes long without a leading 0x or 0X. Example using five patterns: -P ff, a5c0, 00, fdb97531, 02468ace |

**Note:** If no patterns are specified for the erase disk option in command line mode, then the default pattern of 00 is used.

### Hardfile attached to PCI SCSI RAID adapter

This function formats the physical disks attached to a PCI SCSI RAID adapter. This task can be run directly from the AIX command line. The command line syntax is: `diag -c -d RAIDadapterName -T "format {-l chld | -A }"`

| Flag | Description                                                                                                        |
|------|--------------------------------------------------------------------------------------------------------------------|
| -l   | Physical disk channel/ID (An example of a physical disk channel/ID is 27, where the channel is 2 and the ID is 7.) |
| -A   | All disks                                                                                                          |

### Optical media

Use the following functions to check and verify optical media:

- **Optical Media Initialize**  
Formats the media without certifying. This function does not reassign the defective blocks or erase the data on the media. This option provides a quick way of formatting the media and cleaning the disk.

**Note:** It takes approximately one minute to format the media.

- **Optical Media Format and Certify**  
Formats and certifies the media. This function reassigns the defective blocks and erases all data on the media.

This task can be run directly from the AIX command line. The command line syntax is: `diag -c -d deviceName -T "format -s {initialize | fmtcert} "`

### Option

| Option     | Description                      |
|------------|----------------------------------|
| initialize | Formats media without certifying |
| fmtcert    | Formats and certifies the media  |

### DVD-RAM media

- Initialize

Formats the media without certifying. This function does not reassign the defective blocks or erase the data on the media. This format type can only be used with previously formatted media.

- Format and Certify

Formats and certifies the media. This function reassigns the defective blocks and erases the data on the media by writing an initialization pattern to the entire media.

This task can be run directly from the AIX command line. The command line syntax is: `diag -c -d deviceName -T "format -s {initialize|fmtcert} "`

### Flag

| Flag          | Description                                               |
|---------------|-----------------------------------------------------------|
| -c            | No console mode                                           |
| -d            | Used to specify a device                                  |
| -s initialize | Initialize the media (quick format). This is the default. |
| -s fmtcert    | Formats and certifies the media.                          |
| -T            | Used to specify the format task                           |

### Diskette format

This selection formats a diskette by writing patterns to it.

### Gather system information

This service aid uses the AIX `snap` command to collect configuration information on networks, file systems, security, the kernel, the ODM, and other system components. You can also collect SSA adapter and disk drive configuration data, or AIX trace information for software debugging.

The output of the SNAP service aid can be used by field service personnel, or it can be put on removable media and transferred to remote locations for more extensive analysis.

To use the SNAP task, select Gather system information from the task list. You can select which components you want to collect information for, and where to store the data (hard disk or removable media).

## Generic microcode download

**Note:** In AIX diagnostics versions 5.2.0.75, 5.3.0.30, and later, "Generic microcode download" is a subtask that can be accessed after selecting "Microcode Tasks".

The generic microcode download service aid provides a means of executing a genucode script from a diskette or tape. The purpose of this generic script is to load microcode to a supported resource.

The genucode program should be downloaded onto diskette or tape in tar format while the microcode image itself goes onto another one in restore format. Running the generic microcode download task will search for the genucode script on diskette or tape and execute it. It will ask for a Genucode media to be inserted into the drive. The service aid moves the genucode script file to the /tmp directory and runs the program that downloads the microcode to the adapter or device.

This service aid is supported in both concurrent and standalone modes from disk, LAN, or loadable media.

## Hot plug task

**Attention:** The Linux operating system does not support some hot pluggable procedures. Also, Linux does not support hot plugging any hot pluggable PCI adapters or devices. A system with Linux installed on one or more partitions must be shut down and powered off before replacing any PCI adapter or device assigned to a Linux partition. Follow the non-hot pluggable adapter or device procedures when replacing a PCI adapter or device in any partition with Linux installed.

The hot plug task provides software function for those devices that support hot plug or hot plug capability. This includes PCI adapters, SCSI devices, and some RAID devices. This task was previously known as "SCSI Device Identification and Removal" or "Identify and Remove Resource."

The hot plug task has a restriction when running in standalone or online service mode; new devices cannot be added to the system unless there is already a device with the same FRU part number installed in the system. This restriction is in place because the device software package for the new device cannot be installed in standalone or online service mode.

Depending on the environment and the software packages installed, selecting this task displays the following subtasks:

- PCI hot plug manager
- SCSI hot plug manager
- RAID hot plug devices

To run the hot plug task directly from the command line, type the following: `diag -T"identifyRemove"`

If you are running the diagnostics in online concurrent mode, run the missing options resolution procedure immediately after removing any device.

If the missing options resolution procedure runs with no menus or prompts, device configuration is complete. Select the device that has an uppercase **M** in front of it in the resource list so that missing options processing can be done on that resource.



## PCI hot plug manager

**Attention:** The Linux operating system does not support some hot pluggable procedures. Also, Linux does not support hot plugging any hot pluggable PCI adapters or devices. A system with Linux installed on one or more partitions must be shut down and powered off before replacing any PCI adapter or device assigned to a Linux partition. Please follow the non-hot pluggable adapter or device procedures when replacing a PCI adapter or device in any partition with Linux installed.

The PCI hot plug manager task is a SMIT menu that allows you to identify, add, remove, or replace PCI adapters that are hot pluggable. The following functions are available under this task:

- List PCI hot plug slots
- Add a PCI hot plug adapter
- Replace/remove a PCI hot plug adapter
- Identify a PCI hot plug slot
- Unconfigure devices
- Configure devices
- Install/configure devices added after IPL

The list PCI hot plug slots function lists all PCI hot plug slots. Empty slots and populated slots are listed. Populated slot information includes the connected logical device. The slot name consists of the physical location code and the description of the physical characteristics for the slot.

The add a PCI hot plug adapter function is used to prepare a slot for the addition of a new adapter. The function lists all the empty slots that support hot plug. When a slot is selected, the visual indicator for the slot blinks at the identify rate. After the slot location is confirmed, the visual indicator for the specified PCI slot is set to the action state. This means the power for the PCI slot is off and the new adapter can be plugged in.

The replace/remove a PCI hot plug adapter function is used to prepare a slot for adapter exchange. The function lists all the PCI slots that support hot plug and are occupied. The list includes the slot's physical location code and the device name of the resource installed in the slot. The adapter must be in the defined state before it can be prepared for hot plug removal. When a slot is selected, the visual indicator for the slot is set to the identify state. After the slot location is confirmed, the visual indicator for the specified PCI slot is set to the action state. This means the power for the PCI slot is off, and the adapter can be removed or replaced.

The identify a PCI hot plug slot function is used to help identify the location of a PCI hot plug adapter. The function lists all the PCI slots that are occupied or empty and support hot plug. When a slot is selected for identification, the visual indicator for the slot is set to the identify state.

The unconfigure devices function attempts to put the selected device, in the PCI hot plug slot, into the defined state. This action must be done before any attempted hot plug function. If the unconfigure function fails, it is possible that the device is still in use by another application. In this case, the customer or system administrator must be notified to quiesce the device.

The configure devices function allows a newly added adapter to be configured into the system for use. This function should also be done when a new adapter is added to the system.

The install/configure devices added after IPL function attempts to install the necessary software packages for any newly added devices. The software installation media or packages are required for this function.

Standalone diagnostics has restrictions on using the PCI hot plug manager. For example:

- Adapters that are replaced must be exactly the same FRU part number as the adapter being replaced.
- New adapters cannot be added unless a device of the same FRU part number already exists in the system, because the configuration information for the new adapter is not known after the standalone diagnostics are booted.
- The following functions are not available from the standalone diagnostics and will not display in the list:
  - ◆ Add a PCI hot plug adapter

- ◆ Configure devices
- ◆ Install/configure devices added after IPL

You can run this task directly from the command line by typing the following command: `diag -d device -T"identifyRemove"`

However, note that some devices support both the PCI hot plug task and the RAID hot plug devices task. If this is the case for the *device* specified, then the hot plug task displays instead of the PCI hot plug manager menu.

More detailed information concerning the PCI hot plug manager can be found in the *AIX Operating System System Management Guide*.

## SCSI hot plug manager

This task was known as "SCSI Device Identification and Removal" or "Identify and Remove Resources" in previous releases. This task allows the user to identify, add, remove, and replace a SCSI device in a system unit that uses a SCSI Enclosure Services (SES) device. The following functions are available:

- List the SES Devices
- Identify a Device Attached to an SES Device
- Attach a Device to an SES Device
- Replace/Remove a Device Attached to an SES Device
- Configure Added/Replaced Devices

The list the SES devices function lists all the SCSI hot plug slots and their contents. Status information about each slot is also available. The status information available includes the slot number, device name, whether the slot is populated and configured, and location.

The identify a device attached to an SES device function is used to help identify the location of a device attached to an SES device. This function lists all the slots that support hot plug that are occupied or empty. When a slot is selected for identification, the visual indicator for the slot is set to the Identify state.

The attach a device to an SES device function lists all empty hot plug slots that are available for the insertion of a new device. After a slot is selected, the power is removed. If available, the visual indicator for the selected slot is set to the remove state. After the device is added, the visual indicator for the selected slot is set to the normal state, and power is restored.

The replace/remove a device attached to an SES device function lists all populated hot plug slots that are available for removal or replacement of the devices. After a slot is selected, the device populating that slot is unconfigured; then the power is removed from that slot. If the unconfigure operation fails, it is possible that the device is in use by another application. In this case, the customer or system administrator must be notified to quiesce the device. If the unconfigure operation is successful, the visual indicator for the selected slot is set to the remove state. After the device is removed or replaced, the visual indicator, if available for the selected slot, is set to the normal state, and power is restored.

**Note:** Before you remove the device, be sure that no other host is using it.

The configure added/replaced devices function runs the configuration manager on the parent adapters that had child devices added or removed. This function ensures that the devices in the configuration database are configured correctly.

Standalone diagnostics has restrictions on using the SCSI hot plug manager. For example:

- Devices being used as replacement devices must be exactly the same type of device as the device being replaced.
- New devices may not be added unless a device of the same FRU part number already exists in the system, because the configuration information for the new device is not known after the standalone

diagnostics are booted.

You can run this task directly from the command line. The command line syntax is:

```
diag -d device-T"identifyRemove"
OR
diag -c -d device -T"identifyRemove -a identify?remove"
```

| Flag | Description                                                                                                                                                |
|------|------------------------------------------------------------------------------------------------------------------------------------------------------------|
| -a   | Specifies the option under the task.                                                                                                                       |
| -c   | Run the task without displaying menus. Only command line prompts are used. This flag is only applicable when running an option such as identify or remove. |
| -d   | Indicates the SCSI device.                                                                                                                                 |
| -T   | Specifies the task to run.                                                                                                                                 |

## SCSI and SCSI RAID hot plug manager

This task was previously called "SCSI hot-swap manager", "SCSI device identification and removal" or "identify and remove resources" in previous releases. This task allows the user to identify, add, remove, and replace a SCSI device in a system unit that uses a SCSI hot plug enclosure device. This task also performs these functions on a SCSI RAID device attached to a PCI-X RAID controller. The following functions are available:

- List the SCSI hot plug enclosure devices
- Identify a device attached to a SCSI hot plug enclosure device
- Attach a device to a SCSI hot plug enclosure device
- Replace/remove a device attached to an SCSI hot plug enclosure device
- Configure added/replaced devices

The list the SCSI hot plug enclosure devices function lists all the SCSI hot plug slots and their contents. Status information about each slot is also available. The status information available includes the slot number, device name, whether the slot is populated and configured, and location.

The identify a device attached to an SCSI hot plug enclosure device function is used to help identify the location of a device attached to a SCSI hot plug enclosure device. This function lists all the slots that support hot plug that are occupied or empty. When a slot is selected for identification, the visual indicator for the slot is set to the identify state. The attach a device to a SCSI hot plug enclosure device function lists all empty hot plug slots that are available for the insertion of a new device. After a slot is selected, the power is removed. If available, the visual indicator for the selected slot is set to the remove state. After the device is added, the visual indicator for the selected slot is set to the normal state, and power is restored.

The replace/remove a device attached to an SCSI hot plug enclosure device function lists all populated hot plug slots that are available for removal or replacement of the devices. After a slot is selected, the device populating that slot is unconfigured, the power is removed from that slot. If the unconfigure operation fails, it is possible that the device is in use by another application. In this case, the customer or system administrator must be notified to quiesce the device. If the unconfigure operation is successful, the visual indicator for the selected slot is set to the remove state. After the device is removed or replaced, the visual indicator, if available for the selected slot, is set to the normal state, and power is restored.

**Note:** Before you remove the device, be sure that no other host is using it.

The configure added/replaced devices function runs the configuration manager on the parent adapters that had child devices added or removed. This function ensures that the devices in the configuration database are

configured correctly.

Standalone diagnostics has restrictions on using the SCSI hot plug manager. For example:

- Devices being used as replacement devices must be exactly the same type of device as the device being replaced
- New devices may not be added unless a device of the same FRU part number already exists in the system, because the configuration information for the new device is not known after the standalone diagnostics are booted.

You can run this task directly from the command line. The command syntax is:

```
diag -d device -T"identifyRemove
```

OR

```
diag -d device -T"identifyRemove -a identify|remove
```

## Flags

| Flags | Description                          |
|-------|--------------------------------------|
| -a    | Specifies the option under the task. |
| -d    | Indicates the SCSI device.           |
| -T    | Specifies the task to run.           |

## RAID hot plug devices

This task allows the user to identify or remove a RAID device in a system unit that uses a SCSI Enclosure Services (SES) device. The following subtasks are available:

- Normal
- Identify
- Remove

The normal subtask is used to return a RAID hot plug device to its normal state. This subtask is used after a device has been identified or replaced. This subtask lists all channel/IDs of the RAID and the status of the devices that are connected. A device in its normal state has power and the check light is off.

The identify subtask is used to identify the physical location of a device or an empty position in the RAID enclosure. This subtask lists all channel/IDs of the RAID and the status of the devices that are connected to the RAID enclosure. If a device is attached to the selected channel/ID, the check light on the device will begin to flash. If the channel/ID does not have a device attached, the light associated with the empty position on the enclosure will begin to flash.

The remove subtask is used to put the RAID hot plug device in a state where it can be removed or replaced. This subtask lists all channel/IDs of the RAID adapter that have devices that can be removed. Only devices with a status of `Failed`, `Spare`, `Warning`, or `Non Existent` can be removed. A device's status can be changed with the AIX `smitty pdam` command. After a device is selected for removal, the check light on the device will begin to flash, indicating that you may physically remove that device.

Standalone diagnostics has restrictions on using the RAID hot plug manager:

- Devices being used as replacement devices must be exactly the same type of device as the device being replaced.
- New devices may not be added unless a device of the same FRU part number already exists in the system because the configuration information for the new device is not known after the standalone diagnostics are booted.

You can run this task directly from the command line. The command line syntax is:

```
diag -c -d <device name> -T "identifyRemove -l <ChId> -s {identify|remove|normal}
```

## Flags

| Flags | Description                                                                                                                                                                |
|-------|----------------------------------------------------------------------------------------------------------------------------------------------------------------------------|
| -c    | Run the task without displaying menus. Only command line prompts are used.                                                                                                 |
| -d    | Raid adapter device name (for example, <code>scraid0</code> ).                                                                                                             |
| -s    | Subtask to execute such as identify, remove, or normal.                                                                                                                    |
| -l    | <i>CHId</i> is the channel number of the RAID adapter and SCSI ID number of the position in the enclosure concatenated together (for example, 27 for channel 2, device 7). |
| -T    | Task to run.                                                                                                                                                               |

## Identify indicators

See the [Component and attention LEDs](#) for a description of the identify indicators task.

## Identify and system attention indicators

This task is used to display or set the identify indicators and the single system attention indicator on the systems that support this function.

Some systems may support only the Identify indicators or only the attention indicator. The identify indicators are used to help physically identify the system/enclosure/FRU in a large equipment room. The attention indicator is used to alert a user that the system needs attention and may have a hardware problem. In most cases, when an identify indicator is set to the Identify state, this results in a flashing LED, and when an attention indicator is set to the attention state, this results in a solid LED.

When a hardware problem has been detected on a system that supports the attention indicator, the indicator is set to an attention state. After the failure has been identified, repaired, and a repair action has been logged, the attention indicator is reset to the normal state.

This task can also be run directly from the command line by typing

```
/usr/lpp/diagnostics/bin/usysident -s {normal | identify} -l location code | -d device name
```

```
/usr/lpp/diagnostics/bin/usysident -t
```

## Flag

| Flag                    | Description                                                                      |
|-------------------------|----------------------------------------------------------------------------------|
| -s {normal   identify}  | Sets the state of the system identify indicator to either normal or identify.    |
| -l <i>location code</i> | Identifies the resource by physical location code.                               |
| -d <i>device name</i>   | Identifies the resource by device name                                           |
| -t                      | Displays a list of all supported identify indicators by physical location codes. |

When this command is used without the -l or the -d flags, the primary enclosure resource is used.

Use the -l flag only in systems that have more than one identify indicator. The -d flag is only supported in levels of diagnostics 5.2.0.30 and higher. Use of the -d flag is preferred over use of the -l flag.

When this command is used without the -s flag, the current state of the identify indicator is displayed.

### Local area network analyzer

This selection is used to exercise the LAN communications adapters (token ring, Ethernet, and (FDDI) Fiber Distributed Data Interface). The following services are available:

- Connectivity testing between two network stations. Data is transferred between the two stations, requiring the user to provide the Internet addresses of both stations.
- Monitoring ring (token ring only). The ring is monitored for a specified period of time. Soft and hard errors are analyzed.

### Log repair action

The log repair action task logs a repair action in the AIX error log. A repair action log indicates that a FRU has been replaced, and error log analysis should not be done for any errors logged before the repair action. The log repair action task lists all resources. Replaced resources can be selected from the list, and when commit (F7 key) is selected, a repair action is logged for each selected resource.

To locate the failing part in a system or partition running AIX, do the following:

1. Log in as root user.
2. At the command line, enter diag.
3. Select the Diagnostics Routines option.
4. When the DIAGNOSTIC MODE SELECTION menu displays, select Problem Determination.
5. When the ADVANCED DIAGNOSTIC SELECTION menu displays, do one of the following: To test a single resource, select the resource from the list. To test all the resources available to the operating system, select All Resources.
6. Press Enter, and wait until the diagnostic programs run to completion, responding to any prompts that appear on the console.
7. Use the location information for the failing part to activate the indicator light that identifies the failing part. For instructions, see Activate the indicator light for the failing part.

### Microcode tasks

**Note:** Microcode tasks are available in AIX diagnostics versions 5.2.0.75, 5.3.0.30, and later.

"Microcode tasks" provides a method for combining similar microcode tasks under a single task topic, while providing a way to access the microcode and flashing features. The combined tasks that are included under "Microcode tasks" are:

- Display microcode level
- Download microcode
- Generic microcode download
- Update system or service processor flash
- Update and manage system flash

Each of the above listed microcode tasks was an individual task prior to AIX diagnostics versions 5.2.0.75 and 5.3.0.30. Each task is individually described in the "Introducing tasks and service aids" topic.

## Periodic diagnostics

This selection provides a tool for configuring periodic diagnostics and automatic error log analysis. You can select a hardware resource to be tested once a day, at a user-specified time.

Hardware errors logged against a resource can also be monitored by enabling automatic error log analysis. This allows error log analysis to be performed every time a hardware error is put into the error log. If a problem is detected, a message is posted to the system console and either sent to the Service Focal Point when there is a HMC attached, or a mail message to the users belonging to the system group containing information about the failure, such as the service request number.

The service aid provides the following functions:

- Add or delete a resource to the periodic test list
- Modify the time to test a resource
- Display the periodic test list
- Modify the error notification mailing list
- Disable or enable automatic error log analysis

## PCI RAID physical disk identify

For a description of the PCI RAID physical disk identify task, see [SCSI RAID Physical Disk Status and Vital Product Data](#).

## PCI SCSI disk array manager

This service aid calls the `smitty pdam fastpath`, and is used to manage a RAID array connected to a SCSI RAID adapter. It may also be run from standalone diagnostics, which are available on systems or partitions with operating systems other than AIX installed on them (these environments do not allow you to run the `smitty pdam` command).

Some of the tasks performed using this service aid include:

- Check device status for the disk array on your system.
- Display information of physical drives and disk arrays.
- Run recovery options on the RAID (which needs to be done at the end of a service call in which you replaced the RAID adapter cache card or changed the RAID configuration)

Other RAID functions are available using this service aid; they should only be used by the system administrator who is familiar with the RAID configuration. These functions are normally done when booting AIX by running `smitty pdam` from the command line. Without knowledge of how the RAID was set up, these functions can cause loss of data stored on the RAID.

## Process supplemental media

Process supplemental media contains all the necessary diagnostic programs and files required to test a particular resource. The supplemental media is normally released and shipped with the resource as indicated on the diskette label. Diagnostic supplemental media must be used when the device support has not been incorporated into the latest diagnostic CD-ROM.

This task processes the diagnostic supplemental media. Insert the supplemental media when you are prompted; then press Enter. After processing has completed, go to the resource selection list to find the resource to test.

#### Notes:

1. This task is supported in standalone diagnostics only.
2. Process and test one resource at a time. Run diagnostics after each supplemental media is processed. (For example, if you need to process two supplemental media, run diagnostics twice, once after each supplement media is processed.)

#### Run diagnostics

The run diagnostics task invokes the resource selection list menu. When the commit key is pressed, diagnostics are run on all selected resources.

The procedures for running the diagnostics depend on the state of the diagnostics run-time options. See [Display or change diagnostic run-time options](#).

#### Run error log analysis

The run error log analysis task invokes the resource selection list menu. When the commit key is pressed, error log analysis is run on all selected resources.

#### Run exercisers

The run exercisers task provides a tool to troubleshoot intermittent system problems, to test hardware, and to verify replacement parts. When AIX error logging is enabled, the run error log analysis task can be used to analyze errors after the exerciser completes. Hardware errors are logged in the AIX error log. Miscompares and recoverable errors are not reported. However, they may be logged in the AIX error log when logging thresholds are exceeded.

The diagnostic supervisor typically sets up temporary work files in the /tmp directory to log messages and device statistics. These files are deleted before an exerciser session begins. In addition to individual exerciser requirements, the following requirements pertain to all exercisers:

- Only supported in concurrent or service modes
- Not supported from standalone diagnostics
- System performance will be degraded while running the exerciser, so it is recommended that customer applications be shut down before it is run.
- At least 1 MB of free storage in the /tmp directory is available



From the TASK SELECTION LIST menu select Run Exercisers. The RESOURCES SELECTION LIST menu displays. From this menu, choose the resources you want to exercise, and then select **commit** to start the run exerciser task. An intermediate pop-up window might display, stating system performance will be degraded. (The pop-up window does not display if the task had previously been selected). Press Enter and the EXERCISER OPTIONS menu prompts for the type of test to run.

The EXERCISER OPTIONS menu displays the following options:

- Option 1 - Short Exercise. Exercises the resources within a relatively short time and exits.
- Option 2 - Extended Exercise. Allows greater flexibility and control over resources and test duration.

After choosing the short exercise option, additional menus, pop-up windows and prompts may display for each resource. Read any text and carefully complete any prompts before committing. The exercisers start, and the device status screen displays. The exercisers runs 5 to 10 minutes depending on the number of processors, processor speed, memory size, and I/O configuration.

After choosing the extended exercise option, additional menus, pop-up windows and prompts may display for each resource. Read any text and carefully fill out any prompts before committing. The system exerciser main menu displays. From this menu, the exercisers can be activated through:

- Option 1 - Short Exercise
- Option 2 - Extended Exercise
- Option x (where exercises are exited)

For information about using other available options, see the help text.

When the task completes, any errors that were encountered are displayed for review. Finally, an exerciser complete pop-up window displays.

To continue, press Enter. The TASK SELECTION LIST menu displays.

If miscompare errors were encountered, run diagnostics on the resource. If the problem is not reported, contact your service support structure. If any other error were encountered, select and run the error log analysis task. If Error Log Analysis does not report a problem, contact your service support structure.

### Exerciser commands (CMD)

Use the following commands as needed in the exerciser menus and reports. Not all commands are available in each menu or report.

| CMD | Description                               |
|-----|-------------------------------------------|
| a   | Acknowledge an error                      |
| b   | Back one page                             |
| c   | Toggle between cycle count and last error |
| e   | View the AIX error log                    |
| f   | Page forward one page                     |
| q   | Return to Main Menu                       |
| r   | Refresh screen                            |
| s   | Enable or disable beep on error           |
| x   | Exit system exerciser                     |

## Abbreviations

The following list describes abbreviations used in the exerciser reports.

### Acronym

|     | Description                                                       |
|-----|-------------------------------------------------------------------|
| COE | Continue on error (use number to select).                         |
| CP  | Device has run the specified number of cycles and is not running. |
| DD  | The exerciser has been terminated by a signal.                    |
| ER  | Device has stopped with an error.                                 |
| HG  | The device is hung.                                               |
| HOE | Halt on error (use number to select).                             |
| RN  | Device is running.                                                |
| ST  | Device is stopped.                                                |

## Memory exerciser

The memory exerciser is labeled `mem0`. The exerciser requests as many memory buffers as possible from AIX. The exerciser fills these buffers with specific bit patterns and then compares them to the original bit patterns. If memory is removed as a result of processors being reconfigured dynamically, the exerciser terminates.

On systems with multiple processors, a process is started for each processor. The free memory space is split evenly among the available processors, thus reducing the time required to exercise all of the memory.

Running this service aid requires 128 KB of free space in `/etc/lpp/diagnostics/data`.

## Tape exerciser

The tape exerciser is labeled `rmtx`, where `x` is the number of a specific device. The exerciser performs read, write, and compare operations using known data patterns. A tape device and diagnostic test cartridge are required to run this exerciser. The actual diagnostics test cartridge depends upon the specific tape device being tested. The exerciser automatically rewinds the tape. Test requirements are:

- Tape device
- Diagnostic test cartridge (the part number depends upon tape device)

## Diskette exerciser

The diskette exerciser is labeled `fdx`, where `x` is the number of a specific device. The exerciser performs read, write, and compare operations using known data patterns. A scratch diskette is required to run this exerciser; data on the scratch diskette is destroyed. Test requirements are:

- Diskette device
- Scratch diskette (data on diskette is destroyed)

### CD-ROM exerciser

The CD-ROM exerciser is labeled `cdx`, where `x` is the number of a specific device. The exerciser performs read and compare operations using known data patterns. A CD-ROM device and a test disc is required to run this exerciser. Test requirements are:

- CD-ROM device
- Test disc P/N 81F8902

### Floating point exerciser

The floating point exerciser is labeled `procx`, where `x` is the number of the processor containing the floating point unit. The exerciser performs load/store and arithmetic operations using floating point registers and instructions. The floating point instructions are executed using static values and the outcome of the operation is compared with the expected result. Any mismatch results in an error condition. If the processor is in use by the exerciser and is removed as a result of dynamic logical partitioning, the exerciser terminates.

### Save or restore hardware management policies

Use this service aid to save or restore the settings from ring indicate power-on policy, surveillance policy, remote maintenance policy and reboot policy. The following options are available:

- Save Hardware Management Policies

This selection writes all of the settings for the hardware-management policies to the following file:  
`/etc/lpp/diagnostics/data/hmpolicies`

- Restore Hardware Management Policies

This selection restores all of the settings for the hardware-management policies from the contents of the following file: `/etc/lpp/diagnostics/data/hmpolicies`

You can access this service aid directly from the AIX command line by typing:

```
/usr/lpp/diagnostics/bin/uspchrp -a
```

### SCSI bus analyzer

This service aid allows you to diagnose a SCSI bus problem in a freelance mode.

To use this service aid, the user should understand how a SCSI bus works. Use this service aid when the diagnostics cannot communicate with anything on the SCSI bus and cannot isolate the problem. Normally the procedure for finding a problem on the SCSI bus with this service aid is to start with a single device attached, ensure that it is working, then start adding additional devices and cables to the bus, ensuring that each one works. This service aid works with any valid SCSI bus configuration.

The SCSI bus service aid transmits a SCSI inquiry command to a selectable SCSI address. The service aid then waits for a response. If no response is received within a defined amount of time, the service aid displays a timeout message. If an error occurs or a response is received, the service aid then displays one of the following messages:

- The service aid transmitted a SCSI Inquiry Command and received a valid response back without any errors being detected.
- The service aid transmitted a SCSI Inquiry Command and did not receive any response or error status back.
- The service aid transmitted a SCSI Inquiry Command and the adapter indicated a SCSI bus error.
- The service aid transmitted a SCSI Inquiry Command and an adapter error occurred.
- The service aid transmitted a SCSI Inquiry Command and a check condition occur.

When the SCSI bus service aid is started a description of the service aid displays.

Pressing the Enter key displays the adapter selection menu. Use this menu to enter the address to transmit the SCSI Inquiry Command.

When the adapter is selected, the SCSI bus address selection menu displays. Use this menu to enter the address to transmit the SCSI inquiry command.

After the address is selected, the SCSI bus test run menu displays. Use this menu to transmit the SCSI inquiry command by pressing Enter. The service aid then indicates the status of the transmission. When the transmission is completed, the results of the transmission displays.

#### Notes:

1. A check condition can be returned when the bus or device is working correctly.
2. If the device is in use by another process, AIX does not send the command.

## SCSI RAID physical disk status and vital product data

**Note:** This task was previously known as the PCI RAID physical disk identify task.

Use this service aid when you want to look at the vital product data for a specific disk attached to a RAID adapter. This service aid displays all disks that are recognized by the PCI RAID adapter, along with their status, physical location, microcode level, and other vital product data. The physical location of a disk consists of the channel number of the RAID adapter and the SCSI ID number of the position in the enclosure. The microcode level is listed next to the physical location of the disk.

You can run this task directly from the command line with the following command syntax:

```
diag -c -d < device name > -T "identify"
```

#### Flags

| Flags | Description                                                                |
|-------|----------------------------------------------------------------------------|
| -c    | Run the task without displaying menus. Only command line prompts are used. |
| -d    | RAID adapter device name (for example, scraid0).                           |
| -T    |                                                                            |

Task to run.

### SCSD tape drive service aid

This service aid allows you to obtain the status or maintenance information from a SCSD tape drive. Not all models of SCSD tape drive are supported.

The service aid provides the following options:

- Display time since a tape drive was last cleaned. The time since the drive was last cleaned displays on the screen, as well as a message regarding whether the drive is recommended to be cleaned.
- Copy a tape drive's trace table. The trace table of the tape drive is written to diskettes or a file. The diskettes must be formatted for DOS. Writing the trace table may require several diskettes. The actual number of diskettes is determined by the size of the trace table. Label the diskettes as follows:

TRACEx.DAT (where *x* is a sequential diskette number). The complete trace table consists of the sequential concatenation of all the diskette data files.

When the trace table is written to a disk file, the service aid prompts for a file name. The default name is: /tmp/TRACE. *x*, where *x* is the AIX name of the SCSD tape drive being tested.

- Display or copy a tape drive's log sense information. The service aid provides options to display the log sense information to the screen, to copy it to a DOS formatted diskette, or to copy it to a file. The file name LOGSENSE.DAT is used when the log sense data is written to the diskette. The service aid prompts for a file name when you have selected that the log sense data is to be copied to a file.

This service aid can be run directly from the AIX command line. See the following command syntax (path is /usr/lpp/diagnostics/bin/utape):

```
utape -h | -? -d device -n | -l | -t
OR
utape -c -d device -v {-n | {-l | -t} {-D | -f filename}}
```

#### Flag

| Flag   | Description                                                                                                                                                                                                                       |
|--------|-----------------------------------------------------------------------------------------------------------------------------------------------------------------------------------------------------------------------------------|
| -c     | Run the service aid without displaying menus. The return code indicates success or failure. The output is suppressed except for the usage statement and the numeric value for hours since cleaning (if -n and -D flags are used). |
| -D     | Copy data to diskette.                                                                                                                                                                                                            |
| -f     | Copy data to the file name given after this flag or to a default file name if no name is specified.                                                                                                                               |
| -h, -? | Display a usage statement and/or return code. If the -c flag is present, only the return code displays to indicate the service aid did not run. If the -c is not used, a usage statement displays and the service aid exits.      |
| -l     | Display or copy log sense information.                                                                                                                                                                                            |
| -n     | Display time since drive was last cleaned.                                                                                                                                                                                        |
| -t     | Copy trace table.                                                                                                                                                                                                                 |
| -v     | Verbose mode. If the -c flag is present, the information displays on the screen. If the -n flag is present, the information about tape-head cleaning is printed.                                                                  |

### Spare sector availability

This selection checks the number of spare sectors available on the optical disk. The spare sectors are used to reassign when defective sectors are encountered during normal usage or during a format and certify operation. Low availability of spare sectors indicates that the disk must be backed up and replaced. Formatting the disk does not improve the availability of spare sectors.

You can run this task directly from the AIX command line. The command syntax is: `diag -c -d deviceName -T chkspares`

## SSA service aid

This service aid provides tools for diagnosing and resolving problems on SSA-attached devices. The following tools are provided:

- Set Service Mode
- Link Verification
- Configuration Verification
- Format and Certify Disk

## System fault indicator

For a description of the system fault indicator task, see [Component and attention LEDs](#).

## System identify indicator

For a description of the system fault indicator task, see [Component and attention LEDs](#).

## Update disk-based diagnostics

This service aid allows fixes (APARs) to be applied.

This task invokes the SMIT update software by fix (APAR) task. The task allows the input device and APARs to be selected. You can install any APAR using this task.

## Update system or service processor flash

### Notes:

1. On ESCALA PL Series Power5, OpenPower, and JS20 systems, this task has been replaced with the "Update and manage system Flash" task.

2. In AIX diagnostics versions 5.2.0.75, 5.3.0.30, and later, "Update system or service processor flash" is a subtask that can be accessed after selecting "Microcode Tasks".

**Attention:** If the system is running on a logically partitioned system, ask the customer or system administrator if a service partition has been designated.

- If a service partition has been designated, ask the customer or system administrator to shut down all of the partitions except the one with service authority. The firmware update can then be done using the service aid or the AIX command line in that partition.
- If a service partition has not been designated, the system must be shut down. If the firmware update image is available on backup diskettes or optical media, the firmware update can then be done from the service processor menus as a privileged user. If the firmware update image is in a file on the system, reboot the system in a full system partition and use the following normal firmware update procedures.

If the system is already in a full system partition, use the following normal firmware update procedures.

This selection updates the system or service processor flash. Some systems may have separate images for system and service processor firmware; newer systems have a combined image that contains both in one image.

Look for additional update and recovery instructions with the update kit. You need to know the fully qualified path and file name of the flash update image file provided in the kit. If the update image file is on a diskette or optical media, the service aid can list the files on the diskette or optical media for selection. The diskette must be a valid backup format diskette.

Refer to the update instructions with the kit, or the service guide for the system unit to determine the current level of the system unit or service processor flash memory.

When this service aid is run from online diagnostics, the flash update image file is copied to the /var file system. It is recommended that the source of the microcode that you want to download be put into the /etc/microcode directory on the system. If there is not enough space in the /var file system for the new flash update image file, an error is reported. If this error occurs, exit the service aid, increase the size of the /var file system, and retry the service aid. After the file is copied, a screen requests confirmation before continuing with the flash update. When you continue the update flash, the system reboots using the shutdown -u command. The system does not return to the diagnostics, and the current flash image is not saved. After the reboot, you can remove the /var/update\_flash\_image file.

When this service aid is run from standalone diagnostics, the flash update image file is copied to the file system from diskette, optical media, or from the NIM server. Using a diskette, the user must provide the image on backup format diskette because the user does not have access to remote file systems or any other files that are on the system. If using the NIM server, the microcode image must first be copied onto the NIM server in the /usr/lib/microcode directory pointed to the NIM SPOT (from which you plan to have the NIM client boot standalone diagnostics) prior to performing the NIM boot of diagnostics. Next, a NIM check operation must be run on the SPOT containing the microcode image on the NIM server. After performing the NIM boot of diagnostics one can use this service aid to update the microcode from the NIM server by choosing the /usr/lib/microcode directory when prompted for the source of the microcode that you want to update. If not enough space is available, an error is reported, stating additional system memory is needed. After the file is copied, a screen requests confirmation before continuing with the flash update. When you continue with the update, the system reboots using the reboot -u command. You may receive a Caution: some process(es) wouldn't die message during the reboot process, you can ignore this message. The current flash image is not saved.

You can use the update\_flash command in place of this service aid. The command is located in the /usr/lpp/diagnostics/bin directory. The command syntax is as follows:

```
update_flash -q -f file_name
update_flash -q -D device_name -f file_name
update_flash -q -D update_flash -q -D device_name -l
```

**Attention:** The `update_flash` command reboots the entire system. Do not use this command if more than one user is logged in to the system.

| Flag | Description                                                                                                                                                                |
|------|----------------------------------------------------------------------------------------------------------------------------------------------------------------------------|
| -D   | Specifies that the flash update image file is on diskette. The <i>device_name</i> variable specifies the device. The default <i>device_name</i> is <code>/dev/fd0</code> . |
| -f   | Flash update image file source. The <i>file_name</i> variable specifies the fully qualified path of the flash update image file.                                           |
| -l   | Lists the files on a diskette, from which the user can choose a flash update image file.                                                                                   |
| -q   | Forces the <code>update_flash</code> command to update the flash EPROM and reboot the system without asking for confirmation.                                              |

## Update and manage system flash

### Notes:

1. For systems other than ESCALA PL Series, OpenPower, and JS20, refer to the [Update system or service processor flash](#) task.
2. In AIX diagnostics versions 5.2.0.75, 5.3.0.30, and later, "Update and manage system flash" is a subtask that can be accessed after selecting "Microcode Tasks".
3. For detailed firmware update scenarios, see [Getting Fixes](#).

**Attention:** If the system is managed by an HMC, the firmware update must be done via the HMC. Refer to [Getting Fixes](#) for detailed instructions. If the system is not managed by an HMC, the firmware update can be done using the service aid or the AIX command line.

This selection validates a new system firmware flash image and uses it to update the system temporary flash image. This selection can also be used to validate a new system firmware flash image without performing an update, commit the temporary flash image, and reject the temporary flash image. For detailed instructions on using this service aid to update the server firmware, refer to [Getting Fixes](#).

When this service aid is run from online diagnostics, the flash update image file is copied to the `/var` file system. If there is not enough space in the `/var` file system for the new flash update image file, an error is reported. If this error occurs, exit the service aid, increase the size of the `/var` file system, and retry the service aid. After the file is copied, a screen requests confirmation before continuing with the flash update. When you continue the update flash, the system reboots using the `shutdown -u` command. The system does not return to the diagnostics, and the current flash image is not saved. After the reboot, you can remove the `/var/update_flash_image` file.

When this service aid is run from standalone diagnostics, the flash update image file is copied to the file system from optical media, or from the NIM server. If using the NIM server, the server firmware image must first be copied onto the NIM server in the `/usr/lib/microcode` directory pointed to the NIM SPOT (from which you plan to have the NIM client boot standalone diagnostics) prior to performing the NIM boot of diagnostics. Next, a NIM check operation must be run on the SPOT containing the microcode image on the NIM server. After performing the NIM boot of diagnostics one can use this service aid to update the microcode from the NIM server by choosing the `/usr/lib/microcode` directory when prompted for the source of the microcode that you want to update. If not enough space is available, an error is reported, stating additional system memory is



needed. After the file is copied, a screen requests confirmation before continuing with the flash update. When you continue with the update, the system reboots using the `reboot -u` command. You may receive a message that says: "Caution: some process(es) wouldn't die" during the reboot process; you can ignore this message. The current flash image is not saved.

You can use the `update_flash` command in place of this service aid. The command is located in the `/usr/lpp/diagnostics/bin` directory. The command syntax is as follows:

```
update_flash -q | -v -f file_name
update_flash -q | -v -D device_name -f file_name
update_flash -q | -v -D update_flash -l
update_flash -c
update_flash -r
```

**Attention:** The `update_flash` command reboots the entire system. Do not use this command if more than one user is logged in to the system.

## Flag

| Flag | Description                                                                                                                                                                      |
|------|----------------------------------------------------------------------------------------------------------------------------------------------------------------------------------|
| -D   | Specifies that the flash update image file is on diskette. The <i>device_name</i> variable specifies the device. The default <i>device_name</i> is <code>/dev/fd0</code> .       |
| -f   | Flash update image file source. The <i>file_name</i> variable specifies the fully qualified path of the flash update image file.                                                 |
| -l   | Lists the files on a diskette, from which the user can choose a flash update image file.                                                                                         |
| -q   | Forces the <code>update_flash</code> command to update the flash EPROM and reboot the system without asking for confirmation.                                                    |
| -v   | Validates the flash update image. No update will occur. This flag is not supported on all systems.                                                                               |
| -c   | Commits the temporary flash image when booted from the temporary image. This overwrites the permanent image with the temporary image. This flag is not supported on all systems. |
| -r   | Rejects the temporary image when booted from the permanent image. This overwrites the temporary image with the permanent image. This flag is not supported on all systems.       |

## 7135 RAIDiant Array service aid

The 7135 RAIDiant Array service aids contain the following functions:

- Certify LUN
  - Reads and checks each block of data in the logical unit number (LUN). If excessive errors are encountered, the user is notified.
- Certify Spare Physical Disk
  - Allows the user to certify (check the integrity of the data) on drives designated as spares.
- Format Physical Disk
  - Formats a selected disk drive.
- Array Controller Microcode Download
  - Allows the microcode on the 7135 controller to be updated when required.
- Physical Disk Microcode Download

Updates the microcode on any of the disk drives in the array.

- Update EEPROM

Updates the contents of the EEPROM on a selected controller.

- Replace Controller

Replaces a controller in the array.

## Command Examples

To download the adapter microcode, use this command syntax: `diag -c -d deviceName -T "download -B-D-P"`

### Flag

#### Description

- B Download boot block microcode (default to functional microcode)
- D Microcode is on diskette (default to /etc/microcode directory)
- P Download the previous level of microcode (default to latest level)

To download physical disk microcode, use this command syntax : `diag -c -d deviceName -T "download -l Chld -D-P"`

### Flag

#### Description

- D Microcode is on diskette (default to /etc/microcode directory)
- l Physical disk channel/ID (for example, 27)
- P Download the previous level of microcode (default to latest level)

To format a physical disk, use this command syntax: `diag -c -d deviceName -T "format -l Chld"`

### Flag

#### Description

- l Physical disk channel/ID (for example, 27)

To certify a physical disk, use this command syntax: `diag -c -d deviceName -T "certify -l Chld"`

### Flag

#### Description

- l Physical disk channel/ID (for example, 23)

To identify a physical disk, use this command syntax: `diag -c -d deviceName -T "identify"`

Parent topic: [Working with AIX diagnostics](#)

---

## HMC machine code problems

The support organization uses the `pesh` command to look at the HMC's internal machine code to determine how to fix a machine code problem. Only a service representative or support representative can access this feature.

## Launching an xterm shell

You may need to launch an xterm shell to perform directed support from the support center. This may be required if the support center needs to analyze a system dump in order to better understand machine code operations at the time of a failure. To launch an xterm shell, perform the following:

1. Open a terminal by right-clicking the background and selecting Terminals > rshterm.
2. Type the *pesh* command followed by the serial number of the HMC and press Enter.
3. You will be prompted for a password, which you must obtain from your next level of support.

Additional information: [Viewing the HMC console logs](#).

---

## Viewing the HMC console logs

The console logs display error and information messages that the console has logged while running commands.

The service representative can use this information to learn more about what caused an error and how to resolve it. The HMC classifies log entries as either an informational message or an error message. Log entries are identified with an *I* or *E*, respectively. The HMC lists these log entries chronologically, with the most recent shown at the top of the list.

Use the HMC Console Log to view a record of HMC system events. System events are activities that indicate when processes begin and end. These events also indicate whether the attempted action was successful.

To view the HMC log, perform the following:

1. Launch an xterm shell (Refer to [Launching an xterm shell](#)).
2. Once you have entered the password, use the *showLog* command to launch the HMC log window.

The log includes the following information:

- The event's unique ID code
- The date the event occurred
- The time the event occurred
- The log's type
- The name of the attempted action
- The log's reference code
- The status of the log

### View a particular event

To view a particular event, perform the following:

1. Select an event by clicking once on it.
2. Press Enter to get to a summary of the log you selected. From here, you must select a Block ID to display. The blocks are listed next to the buttons and include the following options:

- ◆ Standard Data Block
  - ◆ Secondary Data Block
  - ◆ Microcode Reason / ID Error Information
3. Select the data block you want to view.
  4. Press Enter. The extended information shown for the data block you selected includes the following:
    - ◆ Program name
    - ◆ Current process ID
    - ◆ Parent process ID
    - ◆ Current thread priority
    - ◆ Current thread ID
    - ◆ Screen group
    - ◆ Subscreen group
    - ◆ Current foreground screen process group
    - ◆ Current background screen process group

For information about error messages displayed and recovery for these messages, see the [Troubleshooting](#) topic.

## Disk-drive-enclosure problem-determination procedures

Problem determination procedures are provided by power-on self-tests (POSTs), service request numbers, and maintenance analysis procedures (MAPs). Some of these procedures use the service aids that are described in the user or maintenance information for your system SCSI attachment.

- **Disk drive module power-on self-tests**  
The disk drive module Power-on Self-Tests (POSTs) start each time that the module is switched on, or when a Send Diagnostic command is received. They check whether the disk drive module is working correctly. The POSTs also help verify a repair after a Field Replaceable Unit (FRU) has been exchanged.
- **SCSI interface card power-on self-tests**  
The SCSI interface card Power-On Self Tests (POSTs) start each time power is switched on, or when a Reset command is sent from the using system SCSI attachment. They check only the internal components of the SCSI interface card; they do not check any interfaces to other FRUs.
- **D24 or T24 Disk-drive enclosure LEDs**  
Disk drive enclosure LED positions and definitions.
- **D24 or T24 Maintenance analysis procedures**  
These maintenance analysis procedures (MAPs) describe how to analyze a continuous failure that has occurred in a D24 or T24 that contains one or more SCSI disk drive modules. Failing FRUs of the D24 or T24 can be isolated with these MAPs.

Parent topic: [Detecting problems](#)

## Disk drive module power-on self-tests

The disk drive module Power-on Self-Tests (POSTs) start each time that the module is switched on, or when a Send Diagnostic command is received. They check whether the disk drive module is working correctly. The POSTs also help verify a repair after a Field Replaceable Unit (FRU) has been exchanged.

The tests are POST-1 and POST-2.

POST-1 runs immediately after the power-on reset line goes inactive, and before the disk drive module motor starts. POST-1 includes the following tests:

- Microprocessor
- ROM
- Checking circuits

If POST-1 completes successfully, POST-2 is enabled.

If POST-1 fails, the disk drive module is not configured into the system.

POST-2 runs after the disk drive module motor has started. POST-2 includes the following tests:

- Motor control
- Servo control
- Read and write on the diagnostic cylinder (repeated for all heads)
- Error checking and correction (ECC).

If POST-2 completes successfully, the disk drive module is ready for use with the system.

If POST-2 fails, the disk drive module is not configured into the system.

**Parent topic:** [Disk-drive-enclosure problem-determination procedures](#)

---

## SCSI interface card power-on self-tests

The SCSI interface card Power-On Self Tests (POSTs) start each time power is switched on, or when a Reset command is sent from the using system SCSI attachment. They check only the internal components of the SCSI interface card; they do not check any interfaces to other FRUs.

If the POSTs complete successfully, control passes to the functional microcode of the SCSI interface card. This microcode checks all the internal interfaces of the D24 or T24, and report failures to the host system.

If the POSTs fail, one of the following events occur:

- The SCSI interface card check LED and the D24 or T24 check LED come on.
- If the SCSI interface was configured for high availability using a Dual initiator card the error will be reported. The functional operation of the D24 or T24 is not affected. For example, the customer still has access to all the disk drive modules.
- The functional operation of the D24 or T24 is not affected. For example, the customer still has access to all the disk drive modules.
- The failure is reported:
  - ◆ If the failure occurs at system bring-up time, the host system might detect that the D24 or T24 is missing, and reports an error.
  - ◆ If the failure occurs at any time other than system bring-up time, the hourly health check reports the failure.

**Parent topic:** [Disk-drive-enclosure problem-determination procedures](#)

---

## D24 or T24 Disk-drive enclosure LEDs

Disk drive enclosure LED positions and definitions.

The D24 and T24 use a series of green and amber LEDs. The Light Emitting Diodes (LED)s are located on the front and the back of the disk-drive enclosure and are used to indicate disk drive enclosure and component activity, fault, and power status. The following definition list identifies, defines, and explains the on and off state of each LED. Following the definition list are two illustrations that show the location of each LED.

Disk drive enclosure status LEDs

The two disk drive enclosure status LEDs indicate the following:

- ◇ Power good LED - (solid, not blinking) when lit this green colored LED indicates that the disk-drive enclosure is receiving dc electrical power.
- ◇ Cage Fault LED - (solid, not blinking) when lit this amber colored LED indicates that one of the components located in the disk-drive enclosure has failed.

### Note:

- The failing component can be located either on the front or the rear of the subsystem.
- The disk-drive enclosure might be able to continue operating satisfactorily although the failure of a particular part has been detected.

Disk drive LEDs

Up to twenty four disk drives can be installed into the front and back of the disk-drive enclosure (twelve disk drives per side). Each disk drive contains three LEDs that are visible via light pipes. The light pipes are attached to the disk-drive carrier and extend out the left side of each disk drive.

- ◇ Disk drive activity LED (green) - The disk drive activity LED is controlled by the disk. For most disk drives the green LED is lit when the disk is processing a command. However, for some disk drives a different mode page setting allows the green LED to be lit when the disk drive motor is spinning and the LED blinks toward an off state when a command is in progress.
- ◇ Disk drive fault LED (amber) - The disk fault LED is controlled by the SES processor on the SCSI interface card. The disk drive fault LED can be viewed in one of the following three states:
  - Off - This is the normal state for the disk-drive fault LED
  - On - (solid, not blinking) indicates one of the following:
    - A drive is to be removed
    - The disk drive is faulty
    - Appears on an empty slot where a drive is to be installed
  - Blinking - The disk drive is rebuilding
- ◇ Disk drive identify (green) - The light pipe for this LED is located on the lower left side of the disk drive and is used for the identify function by disk-drive enclosures that are connected to an systems.

**Power supply LEDs**

This disk drive enclosure contains two power supplies and they are located on the back lower third portion of the chassis. The power supply located on the left of the chassis is power supply 1. The power supply located on the right side of the chassis is power supply 2. Each power supply contains four LEDs located on the lower right side. The following list identifies and defines each of the power supply LEDs.

- ◇ Cage fault LED - This is an amber colored LED and is labeled C/F. The power supply cage fault LED provides the same information as the cage fault indicator located on the front of the enclosure.
- ◇ AC good LED - This a green colored LED and is labeled I/G
- ◇ DC power good LED - This green colored LED is labeled D/G. Indicates that the enclosure is getting good dc power. It is on when +1.8 V, +3.3 V, +5 V, and +12 V are good. It goes off when any of the mentioned voltages are not good.
- ◇ Power supply fault LED - This amber colored LED is labeled FLT and comes on solid when there is a fault with the power supply.

The following table explains the fault condition or power supply state indicated by each power supply LED:

Table 1. Power supply fault condition

| LED name               | Normal operation state | Input not present state | Input present state | Fault state |
|------------------------|------------------------|-------------------------|---------------------|-------------|
| Cage fault LED         | OFF                    | OFF                     | ON                  |             |
| AC good LED            | ON                     | OFF                     | ON                  | ON          |
| DC power good LED      | ON                     | OFF                     | OFF                 | OFF         |
| Power supply fault LED | OFF                    | OFF                     | ON                  | OFF         |

**Fan assembly LEDs**

The three disk-drive enclosure fan assemblies are located on the front lower third of the enclosure chassis. There are two LEDs located on each fan. The green colored LED is lit when power to the fan is present. The second LED is amber colored when lit and comes on when the fan needs to be replaced.

**Note:**

- ◇ The fan does not need to be completely dead before the fan fault LED is lit. The fan can be turning either to slow or to fast indicating to the system that it is having a problem.
- ◇ The fans green LED will remain lit even when the amber LED is indicating a fan fault.

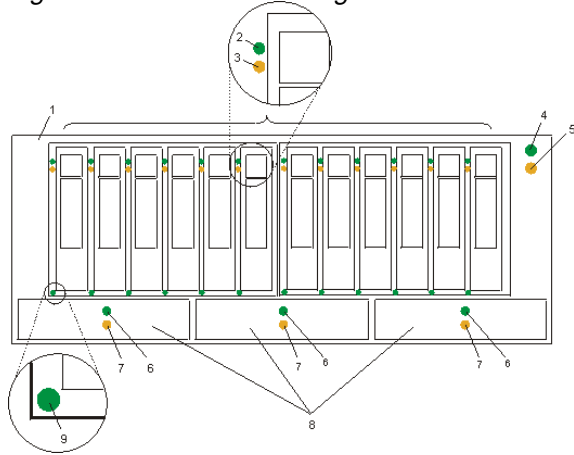
**SCSI interface card LEDs**

Each SCSI interface card has a green and amber colored LED. The green colored LED indicates that activity is taking place through the interface card. The amber colored LED is used as an identify LED

and indicates which one of the SCSI interface cards needs to be replaced.

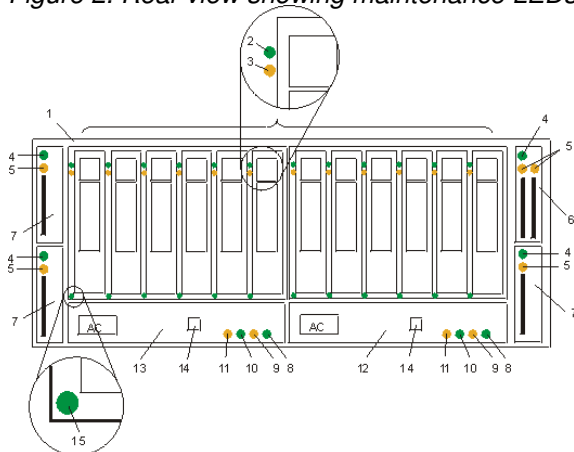
The following two figures show the location of each LEDs found on the D24 or T24.

Figure 1. Front view showing maintenance LEDs on the D24 and T24



| Index Number | Component LED               | Index Number | Component LED           |
|--------------|-----------------------------|--------------|-------------------------|
| 1            | D24 or T24                  | 6            | Fan power LED           |
| 2            | Disk drive activity LED     | 7            | Fan fault LED           |
| 3            | Disk drive fault LED        | 8            | Fan assembly            |
| 4            | Status panel power good LED | 9            | Disk drive identify LED |
| 5            | Status panel cage fault LED |              |                         |

Figure 2. Rear view showing maintenance LEDs on the D24 and T24



| Index Number | Component LED           | Index Number | Component LED                  |
|--------------|-------------------------|--------------|--------------------------------|
| 1            | D24 or T24              | 9            | Power supply dc power good LED |
| 2            | Disk drive activity LED | 10           | Power supply ac power good LED |
| 3            | Disk drive fault LED    | 11           | Cage fault LED                 |

|   |                                      |    |                          |
|---|--------------------------------------|----|--------------------------|
| 4 | SCSI interface card fault LED        | 12 | Power supply 2           |
| 5 | SCSI interface card activity LED     | 13 | Power supply 1           |
| 6 | Dual initiator SCSI interface card   | 14 | Rack indicator connector |
| 7 | Single initiator SCSI interface card | 15 | Disk drive identify LED  |
| 8 | Power supply fault LED               |    |                          |

Parent topic: [Disk-drive-enclosure problem-determination procedures](#)

## D24 or T24 Maintenance analysis procedures

These maintenance analysis procedures (MAPs) describe how to analyze a continuous failure that has occurred in a D24 or T24 that contains one or more SCSI disk drive modules. Failing FRUs of the D24 or T24 can be isolated with these MAPs.

For more information on additional tools to identify missing resources on Linux, go to [Linux tools](#).

### Using the MAPs

**Attention:** Do not remove power from the host system or D24 or T24 unless you are told to in the instructions that you are following. Power cables and external SCSI cables that connect the D24 or T24 to the host system can be disconnected while that system is running.

To isolate the FRUs in the failing D24 or T24, perform the following actions and answer the questions given in these MAPs:

1. When instructed to exchange two or more FRUs in sequence:
  - a. Exchange the first FRU in the list for a new one.
  - b. Verify that the problem is solved. For some problems, verification means running the diagnostic programs (see the using system service procedures).
  - c. If the problem remains:
    - i. Reinstall the original FRU.
    - ii. Exchange the next FRU in the list for a new one.
  - d. Repeat steps 1.b and 1.c until either the problem is solved, or all the related FRUs have been exchanged.
  - e. Perform the next action that the MAP indicates.
2. See [D24 or T24 Disk-drive enclosure LEDs](#) for locations and descriptions of the LEDs and switches.

**Attention:** Disk drive modules are fragile. Handle them with care, and keep them well away from strong magnetic fields.

**Linux tools** Use the `lscfg` command to list all the resources that are available at start up. This information is also saved at each start up and you can use it to identify any missing resources.

To determine if any devices or adapters are missing, compare the list of found resources and partition assignments to the customer's known configuration. Record the location of any missing devices. You can also compare this list of found resources to a prior version of the device tree as the following example shows.



When the partition is restarted, the update device tree command is run and the device tree is stored in the `/var/lib/lsvpd/` directory in a file with the file name device tree `YYYY-MM-DDHH:MM:SS`, where `YYYY` is the year, `MM` is the month, `DD` is the day, and `HH`, `MM`, and `SS` are the hour, minute and second, respectively of the date of creation.

Type the following command at the command line: `cd /var/lib/lsvpd/`, then type the following command: `lscfg -vpd device-tree-2003-03-31-12:26:31`. This command displays the device tree that was created on 03/31/2003 at 12:26:31.

- **MAP 2010: D24 or T24 START**  
This MAP is the entry point to the MAPs for the D24 or T24.
- **MAP 2020: D24 or T24 Power**  
This MAP helps you to isolate FRUs that are causing a power problem on a D24 or T24. This MAP assumes that the disk subsystem is connected to a system that is powered on.
- **MAP 2022: D24 or T24 Power-on**  
This MAP helps you to isolate FRUs that are causing a power problem on a D24 or T24 disk subsystem.
- **MAP 2030: D24 or T24 power control**  
This MAP helps isolate FRUs that are causing a power problem that do not allow the D24 or T24 disk subsystem to power off when it should.
- **MAP 2340: D24 or T24 SCSI bus**  
You are here because the host system cannot access any SCSI device (disk drive module or enclosure services) in a D24 or T24 disk subsystem.
- **MAP 2410: D24 or T24 repair verification**  
Use this MAP to help you verify a repair after a FRU is exchanged for a new one on a D24 or T24 disk subsystem.

**Parent topic:** [Disk-drive-enclosure problem-determination procedures](#)

---

## MAP 2010: D24 or T24 START

This MAP is the entry point to the MAPs for the D24 or T24.

If you are not familiar with these MAPs, read [Using the MAPs](#) first.

You might have been directed to this section because:

- The system problem determination procedures sent you here.
- Action from an SRN list sent you here.
- A problem occurred during the installation of a D24 or T24 or a disk drive module.
- Another MAP sent you here.
- A customer observed a problem that was not detected by the system problem determination procedures.

**Attention:** Do not remove power from the host system or D24 or T24 unless you are told to in the instructions that you are following. Power cables and external SCSI cables that connect the D24 or T24 to the host system can be disconnected while that system is running.

### 1. Does the D24 or T24 emit smoke or is there a burning smell?

NO

Go to step 2.

YES

Go to [MAP 2022: D24 or T24 Power-on](#).

### 2. Are you at this MAP because power is not removed completely from the D24 or T24 when the host systems are switched off?

**Note:** Power will remain on the 7031 for approximately 30 seconds after the last system is powered off.

NO

Go to step 3.

YES

Go to [MAP 2030: D24 or T24 power control](#).

**3. Have you been sent to this MAP from an SRN?**

NO

Go to step 4.

YES

Go to step 7.

**4. Have the system diagnostics or problem determination procedures given you an SRN for the D24 or 31T/24?**

NO

- If the system diagnostics for the D24 or T24 are available, go to step 5.
- If the system diagnostics for the D24 or T24 are not available, but the stand-alone diagnostics are available, do the following:
  - a. Run the stand-alone diagnostics.
  - b. Go to step 6.
- If neither the system diagnostics nor the stand-alone diagnostics are available, go to step 7.

YES

Go to [the List of service request numbers](#) which is available in the *ESCALA Power5 Hardware Information*.

5. a. Run the concurrent diagnostics to the D24 or T24. For information about how to run concurrent diagnostics, see [Loading and Using the AIX online diagnostics or the AIX standalone diagnostics](#) which is available in the *ESCALA Power5 Hardware Information*.
- b. When the concurrent diagnostics are complete, go to step 6.

**6. Did the diagnostics give you an SRN for the D24 or 31T/24?**

NO

Go to step 7.

YES

Go to [the List of service request numbers](#) which are available in the *ESCALA Power5 Hardware Information*.

**7. Is the subsystem check LED flashing?**

NO

Go to step 8.

YES

A device is in Identify mode. A power supply, SCSI card, or disk drive module is to be added or installed.

**8. Is the subsystem check LED on continuously?**

NO

Go to step 12.

YES

Go to step 9.

**9. Does the power-supply assembly have its FLT LED on because its DC On/Off switch is set to Off?**

NO

Go to step 10.

YES

- a. Set the DC On/Off switch to On.
- b. If you still have a problem, return to step 2. Otherwise, go to [MAP 2410: D24 or T24 repair verification](#) to verify the repair.

**10. Does any FRU have its Check or Fault LED on?**

**Note:** The check LED might be on any of the following parts:

- ◆ A SCSI interface card assembly (CARD FAULT LED)
- ◆ A power-supply assembly (FLT LED)
- ◆ A fan assembly (CHK LED)
- ◆ A disk drive module (CHK LED)

NO

In the following sequence, exchange the following FRUs for new FRUs. Ensure that for *each* FRU exchange, you go to [MAP 2410: D24 or T24 repair verification](#) to verify the repair.

- a. SCSI interface card assembly (see the removal and replacement procedures for [D24 or T24 SCSI disk drive enclosure features and parts](#)), and select the appropriate part.
- b. Power supply (see the removal and replacement procedures for [D24 or T24 SCSI disk drive enclosure features and parts](#)), and select the appropriate part.
- c. Fan assembly (see the removal and replacement procedures for [D24 or T24 SCSI disk drive enclosure features and parts](#)), and select the appropriate part.
- d. Frame assembly (see the removal and replacement procedures for [D24 or T24 SCSI disk drive enclosure features and parts](#)), and select the appropriate part.

YES

- a. If the FRU is a fan-and-power-supply assembly, go to step 11. Otherwise, exchange the FRU whose Check LED is on.
- b. Go to [MAP 2410: D24 or T24 repair verification](#) to verify the repair.

**11. Is the enclosure set up for remote power control (that is, is the power control switch of the SCSI interface card assembly set to Off)?**

NO

- a. Exchange, for a new one, the power supply whose FLT LED is on, see the removing/replacing information for [D24 or T24 SCSI disk drive enclosure features and parts](#)), and select Power supply.
- b. Go to [MAP 2410: D24 or T24 repair verification](#) to verify the repair.

YES

- a. Ensure that:
  - The DC On/Off switch is set to On.
  - Both ends of the SCSI cable are correctly connected.
  - The host system is switched on.
- b. If the FLT LED of a power supply is still on, pull out the power supply to disconnect it from the D24 or T24, then push it back to reseat its connectors (see the removal and replacement procedures for [D24 or T24 SCSI disk drive enclosure features and parts](#)).
- c. If the FLT LED is still on, exchange, in the sequence shown, the following FRUs for new FRUs. Ensure that for *each* FRU exchange, you go to [MAP 2410: D24 or T24 repair verification](#) to verify the repair.
  - i. Power supply whose FLT LED is NOT on, (see the removal and replacement procedures for [D24 or T24 SCSI disk drive enclosure features and parts](#)), and select Power supply.
  - ii. SCSI interface card
  - iii. Frame assembly

**12. Is the subsystem power LED on?**

NO

Go to [MAP 2020: D24 or T24 Power](#).

YES

Go to step 13.

**13. Does either power supply assembly have its DC PWR LED off when it should be on?**

NO

Go to step 14.

YES

- a. Exchange the power-supply assembly whose LED is off.
- b. Go to [MAP 2410: D24 or T24 repair verification](#) to verify the repair.

**14. Are you here because access to all the SCSI devices that are in the D24 or T24 has been lost?**

NO

No problem has been found on the D24 or T24. For a final check, go to [MAP 2410: D24 or T24 repair verification](#).

YES

Go to [MAP 2340: D24 or T24 SCSI bus](#).

**Parent topic:** [D24 or T24 Maintenance analysis procedures](#)

## MAP 2020: D24 or T24 Power

This MAP helps you to isolate FRUs that are causing a power problem on a D24 or T24. This MAP assumes that the disk subsystem is connected to a system that is powered on.

**Attention:** Do not remove power from the host system or the disk subsystem unless you are directed to in the following procedures. Power cables and external SCSI cables that connect the disk subsystem to the host system can be disconnected while that system is running.

1. You are here because the subsystem's power Light Emitting Diode (LED) is off.

**Are the 2 middle green LEDs illuminated (AC and DC) on either power supply?**

NO

Go to step 2.

YES

In the sequence shown, exchange the following FRUs for new FRUs. Ensure that for *each* FRU exchange, you go to [MAP 2410: D24 or T24 repair verification](#) to verify the repair.

- a. Power supply (or power supplies if two are present)
- b. Frame assembly

2. Observe the power supply (or power supplies, if two are present).

**Does at least one power supply have its AC PWR LED on?**

NO

Go to step 3.

YES

Go to step 4.

3. Observe the power supplies.

**Are the power supplies switched on?**

NO

- a. Set the On/Off switch to On.
- b. If the problem is still not solved, go to [MAP 2010: D24 or T24 START](#).

YES

Go to step 4.

4. **Does either of the power supplies have its DC PWR LED on or flashing?**

NO

- a. Set the DC On/Off switch to Off, then to On again.
- b. Go to step 5.

YES

In the sequence shown, exchange the following FRUs for new FRUs. Ensure that for *each* FRU exchange, you go to [MAP 2410: D24 or T24 repair verification](#) to verify the repair.

- a. Power supply (or power supplies if two are present)
- b. Frame assembly

If the DC PWR LED is flashing, replace the SCSI interface card assembly. Go to 5.

5. **Does the power supply have its DC PWR LED on now?**

NO

Replace the power supply (or power supplies, if two are present).

YES

Go to 6.

6. **Is the subsystem power LED on continuously?**

NO

In the sequence shown, exchange the following FRUs for new FRUs. Ensure that for *each* FRU exchange, you go to [MAP 2410: D24 or T24 repair verification](#) to verify the repair.

- a. Fan assembly
- b. SCSI interface card assembly
- c. Frame assembly

YES

Go to step [MAP 2410: D24 or T24 repair verification](#) to verify the repair.

7. (from step 6)

Observe the SCSI interface card assemblies.

**Does either SCSI interface card have its TERM POWER LED illuminated?**

NO

Go to step 8.

YES

In the sequence shown, exchange the following FRUs for new FRUs. Ensure that for *each* FRU exchange, you go to [MAP 2410: D24 or T24 repair verification](#) to verify the repair.

- a. Power-supply [D24 or T24 SCSI disk drive enclosure features and parts](#)
- b. Fan (see [D24 or T24 SCSI disk drive enclosure features and parts](#))
- c. SCSI interface card assembly (see [D24 or T24 SCSI disk drive enclosure features and parts](#))

8. (from step 7)

#### Is the host system switched on?

NO

Switch on the host system (see the host system-service information). The 2104 Model DS4 or Model TS4 should switch on when the host system switches on.

YES

If the problem is still not solved, go to [MAP 2010: D24 or T24 START](#).

In the sequence shown, exchange the following FRUs for new FRUs. Ensure that for *each* FRU exchange, you go to [MAP 2410: D24 or T24 repair verification](#) to verify the repair.

- a. External SCSI cables
- b. SCSI interface card assembly (see [D24 or T24 SCSI disk drive enclosure features and parts](#))

**Note:** If the TERM POWER LED is still off, you might have a problem with the SCSI attachment that is in the host system (see the using system service information).

Parent topic: [D24 or T24 Maintenance analysis procedures](#)

---

## MAP 2022: D24 or T24 Power-on

This MAP helps you to isolate FRUs that are causing a power problem on a D24 or T24 disk subsystem.

**Attention:** Do not remove power from the host system or the disk subsystem unless you are directed to in the following procedures. Power cables and external SCSI cables that connect the disk subsystem to the host system can be disconnected while that system is running.

1. In this step you remove most of the FRUs from the D24 or T24 disk subsystem.
  - a. Remove both power supply assemblies, if two are present.
  - b. Remove the fan assemblies.
  - c. Remove the SCSI interface card assemblies. If your disk subsystem has only one SCSI interface card assembly, you do not need to remove the dummy assembly.
  - d. Disconnect all the disk drive modules from the backplane.

**Note:** You do not need to completely remove the disk drive modules.

- e. Go to step 2.
2. Do the following procedure to check the disk subsystem as you reinstall parts.
  - a. Reinstall a power supply into position 1.
  - b. Reinstall the fan assemblies.
  - c. Connect a power cable to the power supply.
  - d. Set the DC On/Off switch of the power supply to On.
  - e. Reinstall one SCSI interface card and connect the appropriate cables to a powered-on system.

**Note:** Unless a procedure needs you to switch off the disk subsystem, leave it switched on for the remainder of this MAP.

**Does the disk subsystem emit smoke or is there a burning smell?**

NO

Go to step 3.

YES

- a. In the sequence shown, exchange the following FRUs for new FRUs. Ensure that for each FRU exchange, you go to [MAP 2410: D24 or T24 repair verification](#) to verify the repair.
  - i. Power supply that you just reinstalled
  - ii. Fan assemblies
  - iii. SCSI interface card
  - iv. Frame assembly

b. Go to step 3.

3. Reinstall the other power supply into position 2.

- a. Connect a power cable to the power supply.
- b. Set the DC On/Off switch of the power supply assembly to On.

**Note:** Unless a procedure needs you to switch off the disk subsystem, leave it switched on for the remainder of this MAP.

**Does the disk subsystem emit smoke or is there a burning smell?**

NO

Go to step 4.

YES

Replace the power supplies.

4.

Reinstall a SCSI interface card assembly into position 1.

**Does the disk subsystem emit smoke or is there a burning smell?**

NO

If the disk subsystem has 2, 3, or 4 SCSI interface cards, go to step 5. Otherwise, go to step 6.

YES

- a. Exchange, for a new one, the SCSI interface card assembly that you have just reinstalled.
- b. If the disk subsystem has two SCSI interface cards, go to step 5. Otherwise, go to step 6.

5. Reinstall the other SCSI interface card assembly into position 2.

**Does the disk subsystem emit smoke or is there a burning smell?**

NO

Go to step 6.

YES

- a. Exchange, for a new one, the SCSI interface card assembly that you just reinstalled.
- b. Go to step 6.

6. Reconnect a disk drive.

**Note:** To engage the disk drive you must close its handle.

**Does the disk subsystem emit smoke or is there a burning smell?**

NO

Go to step 7.

YES

- a. Exchange, for a new one, the disk drive module that you just reconnected.
- b. Go to step 7.

7. Reconnect the next disk drive module.

**Note:** To engage the disk drive you must close its handle.

**Does the disk subsystem emit smoke or is there a burning smell?**

NO

Go to step 8.

YES

- a. Exchange, for a new one, the disk drive module that you just reconnected.
- b. Go to step 8.

8. **Have you reconnected all the disk drive modules?**

NO

Return to step 7.

YES

Go to step 9.

9. **Have you solved the problem?**

NO

Remove all power from the disk subsystem, and call for assistance.

YES

Go to step [MAP 2410: D24 or T24 repair verification](#) to verify the repair.

**Parent topic:** [D24 or T24 Maintenance analysis procedures](#)

---

## MAP 2030: D24 or T24 power control

This MAP helps isolate FRUs that are causing a power problem that do not allow the D24 or T24 disk subsystem to power off when it should.

**Attention:** Do not remove power from the host system or the disk subsystem unless you are directed to in the following procedures. Power cables and external SCSI cables that connect the disk subsystem to the host system can be disconnected while that system is running.

You are here because power is still present at the disk subsystem although the host system is switched off.

1. Observe the cards.

**Does the disk subsystem remain powered on for more than 30 seconds after the last connected system powers off?**

NO

Go to [MAP 2410: D24 or T24 repair verification](#) to verify the repair.

YES

Go to step 2.

2. Disconnect all SCSI cables and wait 30 seconds.

**Is the disk subsystem still powered on?**

NO

Go to step 3.

YES

Suspect an adapter problem in the host system.

3. Remove all SCSI initiator cards.

**Is the disk subsystem still powered on?**

NO

- a. Replug the SCSI interface cards one at a time to determine which one is bad.
- b. If the disk subsystem powers on after replacing a SCSI interface card, replace that SCSI interface card.
- c. Go to [MAP 2410: D24 or T24 repair verification](#) to verify the repair.

YES

Go to step 4.

4.

**Does the disk subsystem have two power supplies?**

NO

- a. In the sequence shown, exchange the following FRUs for new FRUs:
  - i. Power supply assemblies
  - ii. Frame assembly
- b. Go to step 7.

YES

Go to step 5.

5.

**Do both power supplies have their DC PWR LEDs on?**

NO

Go to step 6.

YES

In the sequence shown, exchange the following FRUs for new FRUs. Ensure that for *each* FRU exchange, you go to [MAP 2410: D24 or T24 repair verification](#) to verify the repair.

- a. Power supplies
- b. Frame assembly

**6. Does only one power supply have its DC PWR LED on?**

NO

Go to step 7.

YES

- a. Exchange, for a new one, the power supply whose DC PWR LED remains illuminated.
- b. Go to step 7.

**7. Is the disk subsystem still powered on?**

NO

The problem is solved.

YES

Call for assistance.

Parent topic: [D24 or T24 Maintenance analysis procedures](#)

---

**MAP 2340: D24 or T24 SCSI bus**

You are here because the host system cannot access any SCSI device (disk drive module or enclosure services) in a D24 or T24 disk subsystem.

**Attention:** Do not remove power from the host system or the disk subsystem unless you are directed to in the following procedures. Power cables and external SCSI cables that connect the disk subsystem to the host system can be disconnected while that system is running.

1. Observe the SCSI Bus Split switch.

**Is the disk subsystem powered on?**

NO

Ensure that a SCSI cable is attached to a powered system, and the disk subsystem is powered on. Go to step 2.

YES



Go to step 2.

**2. Is the yellow LED illuminated on the SCSI repeater card?**

NO

Go to step 3.

YES

Replace the SCSI interface card. Go to step 3.

**3. Is the green power LED illuminated on the SCSI repeater card?**

NO

Go to [MAP 2020: D24 or T24 Power](#).

YES

Go to step 4.

**4. Is the SCSI interface card a dual SCSI interface card?**

NO

Go to step 5.

YES

Disconnect one of the SCSI cables, go to step 5.

**5. Note the positions of all the disk drive modules and the dummy disk drive modules so that you can reinstall the modules into their correct slots later.**

a. Remove all of the disk drive modules.

b. Go to step 6.

6.

**Can the host system access enclosure services?**

NO

In the sequence shown, exchange the following FRUs for new FRUs. Ensure that for each FRU exchange, you check whether you can access the disk drive module, to verify the repair.

a. External SCSI cable

b. SCSI interface card assembly

c. Frame assembly

d. Power supplies

e. If the repair is successful, reinstall all of the disk drive modules and cables that were removed in a previous steps.

f. Go to [MAP 2410: D24 or T24 repair verification](#) to verify the repair.

YES

Go to step 7.

**7. Reinsert the disk drive modules that you just removed, one at a time, checking for accessibility.**

**Can the host system access this disk drive module?**

NO

a. In the sequence shown, exchange the following FRUs for new FRUs. Ensure that for *each* FRU exchange, you check whether you can access the disk drive module, to verify the repair.

i. Exchange the disk drive module for a new one.

ii. External SCSI cable

iii. SCSI interface card assembly

iv. Power supply

v. Frame assembly

b. If the repair is successful, reinstall all the disk drive modules and if removed, the SCSI interface card assembly.

c. Go to [MAP 2410: D24 or T24 repair verification](#) to verify the repair.

YES

Go to step 8.

**8. Have you reinstalled all the disk drive modules?**

NO

Go to step 7

YES

Go to step 9.

**9. (from step 8)**

**Can the host system get access to all of the plugged disk drive module and enclosure services?**

NO

Call your support center for assistance.

- a. Exchange the disk drive module for a new one.
- b. Return to step 8.

YES

Go to [MAP 2410: D24 or T24 repair verification](#) to verify the repair.

**Parent topic:** [D24 or T24 Maintenance analysis procedures](#)

---

## MAP 2410: D24 or T24 repair verification

Use this MAP to help you verify a repair after a FRU is exchanged for a new one on a D24 or T24 disk subsystem.

**Attention:** Do not remove power from the host system or the disk subsystem unless you are directed to in the following procedures. Power cables and external SCSI cables that connect the disk subsystem to the host system can be disconnected while that system is running.

1. Ensure that the DC On/Off switch of each power supply assembly is set to On.

### Are all Check LEDs off?

NO

Go to [MAP 2010: D24 or T24 START](#).

YES

Go to step 2.

2. **Can the host system access all SCSI devices?**

NO

Go to [MAP 2010: D24 or T24 START](#).

YES

The repair is complete.

Go to [MAP 0410: Repair checkout](#) for system level repair verification.

**Parent topic:** [D24 or T24 Maintenance analysis procedures](#)

---

## MAP 0410: Repair checkout

Use this MAP to check out the server after a repair is completed.

### Purpose of this MAP

Use this MAP to check out the server after a repair is completed.

**Note:** Only use standalone diagnostics for repair verification when no other diagnostics are available on the system. Standalone diagnostics do not log repair actions.

If you are servicing a cluster, go to the End-of-call procedure in the *Clustered Installation and Service Guide*.

- Step 0410-1

Did you use an AIX diagnostics service aid hot-swap operation to change the FRU?

NO

Go to [Step 0410-2](#).

YES

Go to [Step 0410-4](#).

- Step 0410-2

**Note:** If the system planar or battery has been replaced and you are loading diagnostics from a server over a network, it may be necessary for the customer to set the network boot information for this system before diagnostics can be loaded. The system time and date information should also be set when the repair is completed.

**Do you have any FRUs (for example cards, adapters, cables, or devices) that were removed during problem analysis that you want to put back into the system?**

NO

Go to [Step 0410-3](#).

YES

Reinstall all of the FRUs that were removed during problem analysis. Go to [Step 0410-3](#).

- Step 0410-3

**Is the system or logical partition that you are performing a repair action on running the AIX operating system?**

NO

Go to [Step 0410-5](#).

YES

Go to [Step 0410-4](#).

- Step 0410-4

**Does the system or logical partition you are performing a repair action on have AIX installed?**

**Note:** Answer "NO" to this question if you have just replaced a hard disk in the root volume group.

NO

Go to [Step 0410-5](#).

YES

Go to [Step 0410-6](#).

- Step 0410-5

Run standalone diagnostics from either a CD ROM or from a NIM server. For instruction on running standalone diagnostics from a CD and using an HMC, go to [Using the HMC to load the standalone diagnostics from CD-ROM](#). For instruction on running standalone diagnostics from a CD and not using an HMC, go to [Loading the standalone diagnostics on a system without an HMC attached](#). For instruction on running standalone diagnostics from a NIM server and using an HMC, go to [Running Standalone Diagnostics from a Network Installation Management \(NIM\) Server with an HMC Attached to the System](#). For instruction on running standalone diagnostics from a NIM server, go to [Client Configuration and Booting Standalone Diagnostics from the NIM Server](#).

**Did you encounter any problems?**

NO

Go to [Step 0410-14](#).

YES

Go to [MAP 0020: Problem determination procedure](#).

- Step 0410-6

1. If the system supports slow boot (See [Performing a slow boot](#)), do a slow boot on the system. If the system does not support slow boot, do a normal boot.
2. Power on the system.
3. Wait until the AIX operating system login prompt displays or until system activity on the operator panel or display apparently has stopped.

**Did the AIX Login Prompt display?**

NO

Go to [MAP 0020: Problem Determination Procedure](#).

YES

Go to [Step 0410-7](#).

## • Step 0410-7

If the Resource Repair Action menu is already displayed, go to [Step 0410-10](#); otherwise, do the following:

1. Log into the operating system either with root authority (if needed, ask the customer to enter the password) or use the CE login.
2. Enter the `diag -a` command and check for missing resources. Follow any instructions that display. If an SRN displays, suspect a loose card or connection. If no instructions display, no resources were detected as missing. Continue on to [Step 0410-8](#)

## • Step 0410-8

1. Enter `diag` at the command prompt.
2. Press Enter.
3. Select the Diagnostics Routines option.
4. When the DIAGNOSTIC MODE SELECTION menu displays, select Problem determination.
5. When the ADVANCED DIAGNOSTIC SELECTION menu displays, select the All Resources option or test the FRUs you exchanged, and any devices that are attached to the FRU(s) you exchanged, by selecting the diagnostics for the individual FRU.

**Did the RESOURCE REPAIR ACTION menu (801015) display?**

NO

Go to [Step 0410-9](#).

YES

Go to [Step 0410-10](#).

## • Step 0410-9

**Did the TESTING COMPLETE, no trouble was found menu (801010) display?**

NO

There is still a problem. Go to [MAP 0020: Problem Determination Procedure](#).

YES

Use the Log Repair Action option, if not previously logged, in the TASK SELECTION menu to update the AIX error log. If the repair action was reseating a cable or adapter, select the resource associated with that repair action.

If the resource associated with your action is not displayed on the resource list, select `sysplanar0`.

**Note:** If the system attention indicator is on, this will set it back to the normal state.

Go to [Step 0410-12](#).

## • Step 0410-10

When a test is run on a resource in system verification mode, and that resource has an entry in the AIX error log, if the test on the resource was successful, the RESOURCE REPAIR ACTION menu displays.

After replacing a FRU, you must select the resource for that FRU from the RESOURCE REPAIR ACTION menu. This updates the AIX error log to indicate that a system-detectable FRU has been replaced.

**Note:** If the system attention indicator is on, this action will set it back to the normal state.

Do the following:

1. Select the resource that has been replaced from the RESOURCE REPAIR ACTION menu. If the repair action was reseating a cable or adapter, select the resource associated with that repair action. If the resource associated with your action is not displayed on the resource list, select sysplanar0.
2. Press Commit after you make your selections.

**Did another Resource Repair Action (801015) display?**

NO

If the No Trouble Found menu displays, go to [Step 0410-12](#).

YES

Go to [Step 0410-11](#).

- Step 0410-11

The parent or child of the resource you just replaced may also require that you run the RESOURCE REPAIR ACTION service aid on it.

When a test is run on a resource in system verification mode, and that resource has an entry in the AIX error log, if the test on the resource was successful, the RESOURCE REPAIR ACTION menu displays.

After replacing that FRU, you must select the resource for that FRU from the RESOURCE REPAIR ACTION menu. This updates the AIX error log to indicate that a system-detectable FRU has been replaced.

**Note:** If the system attention indicator is on, this action will set it back to the normal state.

Do the following:

1. From the RESOURCE REPAIR ACTION menu, select the parent or child of the resource that has been replaced . If the repair action was reseating a cable or adapter, select the resource associated with that repair action. If the resource associated with your action is not displayed on the resource list, select sysplanar0.
2. Press COMMIT after you make your selections.
3. If the No Trouble Found menu displays, go to [Step 0410-12](#).

- Step 0410-12

If you changed the service processor or network settings, as instructed in previous MAPs, restore the settings to the value they had prior to servicing the system. If you ran standalone diagnostics from CD-ROM, remove the standalone diagnostics CD-ROM from the system.

**Did you perform service on a RAID subsystem involving changing of the PCI RAID adapter cache card or changing the configuration?**

**Note:** This does not refer to the PCI-X RAID adapter or cache.

NO

Go to [Step 0410-14](#).

YES

Go to [Step 0410-13](#).

- Step 0410-13

Use the Recover Options selection to resolve the RAID configuration. To do this, do the following:

1. On the PCI SCSI Disk Array Manager screen, select Recovery options.
2. If a previous configuration exists on the replacement adapter, this must be cleared. Select Clear PCI SCSI Adapter Configuration. Press F3.
3. On the Recovery Options screen, select Resolve PCI SCSI RAID Adapter Configuration.
4. On the Resolve PCI SCSI RAID Adapter Configuration screen, select Accept Configuration on Drives.

5. On the PCI SCSI RAID Adapter selections menu, select the adapter that you changed.
  6. On the next screen, press Enter.
  7. When you get the Are You Sure selection menu, press Enter to continue.
  8. You should get an OK status message when the recover is complete. If you get a Failed status message, verify that you selected the correct adapter, then repeat this procedure. When recover is complete, exit the operating system.
  9. Go to [Step 0410-14](#).
- Step 0410-14

If the system you are servicing has a Hardware Management Console (HMC) with Service Focal Point (SFP), go to the [End-of-call procedure for systems with Service Focal Point](#).

This completes the repair; return the server to the customer.

## Analyzing problems

Use these instructions and procedures to help you determine the cause of the problem.

- **Problems with loading and starting the operating system (AIX and Linux)**  
If the system is running partitions from partition standby (LPAR), the following procedure addresses the problem in which one partition will not boot AIX or Linux while other partitions boot successfully and run the operating system successfully.
- **Problems with noncritical resources**  
Use this procedure to help you determine the cause of problems with noncritical resources.
- **Intermittent problems**  
An intermittent problem is a problem that occurs for a short time, and then goes away.
- **IPL problems**  
Use these scenarios to help you diagnose your IPL problem:
- **Power problems**  
Use the following table to find out how to begin analyzing a power problem.

Parent topic: [Service provider information](#)

## Problems with loading and starting the operating system (AIX and Linux)

If the system is running partitions from partition standby (LPAR), the following procedure addresses the problem in which one partition will not boot AIX or Linux while other partitions boot successfully and run the operating system successfully.

It is the customer's responsibility to move devices between partitions. If a device must be moved to another partition to run standalone diagnostics, contact the customer or system administrator. (If the optical drive must be moved to another partition, all SCSI devices connected to that SCSI adapter must be moved because moves are done at the slot level, not at the device level.)

Depending on the boot device, a checkpoint may be displayed on the operator panel for an extended period of time while the boot image is retrieved from the device. This is particularly true for tape and network boot attempts. If booting from an optical drive or tape drive, watch for activity on the drive's LED indicator. A blinking LED indicates that the loading of either the boot image or additional information required by the operating system being booted is still in progress. If the checkpoint is displayed for an extended period of time and the drive LED is not indicating any activity, there might be a problem loading the boot image from the device.

### Notes:

1. For network boot attempts, if the system is not connected to an active network or if the target server is inaccessible (which can also result from incorrect IP parameters being supplied), the system will still

- attempt to boot. Because time-out durations are necessarily long to accommodate retries, the system may appear to be hung. Refer to checkpoint CA00 E174.
2. If the partition hangs with a 4-character checkpoint in the display, the partition must be deactivated, then reactivated before attempting to reboot.
  3. If a BA06 000x error code (or a 20EE xxxx error code on an ESCALA PL 245T/R or a 471/85) is reported, the partition is already deactivated and in the error state. Reboot by activating the partition. If the reboot is still not successful, go to step 3.

This procedure assumes that a diagnostic CD-ROM and an optical drive from which it can be booted are available, or that diagnostics can be run from a NIM (network installation management) server. Booting the diagnostic image from an optical drive or a NIM server is referred to as running standalone diagnostics.

1. Is a Hardware Management Console attached to the managed system?
  - ◆ Yes: Continue with the next step.
  - ◆ No: Go to step 3.
2. Look at the service action event error log in the Service Focal Point on the HMC. Perform the actions necessary to resolve any open entries that affect devices in the boot path of the partition or that indicate problems with I/O cabling. Then try to reboot the partition. Does the partition reboot successfully?
  - ◆ Yes: This ends the procedure.
  - ◆ No: Continue with the next step.
3. Boot to the SMS main menu:
  - ◆ If you are rebooting a partition from partition standby (LPAR), go to the properties of the partition and select Boot to SMS, then activate the partition.
  - ◆ If you are rebooting from platform standby, access the ASMI (see [Accessing the Advanced System Management Interface](#)). Select Power/Restart Control, then Power On/Off System. In the AIX/Linux partition mode boot box, select Boot to SMS menu > Save Settings and Power On.

At the SMS main menu, select Select Boot Options and check to see if the intended boot device is correctly specified in the boot list. Is the intended load device correctly specified in the boot list?

  - ◆ Yes: Perform the following:
    - a. Remove all removable media from devices in the boot list from which you do not want to load the operating system.
    - b. If you are attempting to load the operating system from a network, go to step 4.
    - c. If you are attempting to load the operating system from a disk drive or an optical drive, go to step 7.
    - d. No: Go to step 5.
4. If you are attempting to load the operating system from the network, perform the following:
  - ◆ Verify that the IP parameters are correct.
  - ◆ Use the SMS ping utility to attempt to ping the target server. If the ping is not successful, have the network administrator verify the server configuration for this client.
  - ◆ Check with the network administrator to ensure that the network is up. Also ask the network administrator to verify the settings on the server from which you are trying to load the operating system.
  - ◆ Check the network cabling to the adapter.

Restart the partition and try loading the operating system. Does the operating system load successfully?

  - ◆ Yes: This ends the procedure.
  - ◆ No: Go to step 7.
5. Use the SMS menus to add the intended boot device to the boot sequence. Can you add the device to the boot sequence?
  - ◆ Yes: Restart the partition. This ends the procedure.
  - ◆ No: Continue with the next step.
6. Ask the customer or system administrator to verify that the device you are trying to load from is assigned to the correct partition. Then select List All Devices and record the list of bootable devices that displays. Is the device from which you want to load the operating system in the list?
  - ◆ Yes: Go to step 7.
  - ◆ No: Go to step 10.
7. Try to load and run standalone diagnostics against the devices in the partition, particularly against the boot device from which you want to load the operating system. You can run standalone diagnostics from an optical drive or a NIM server. To boot standalone diagnostics, follow the detailed procedures

in [Running the online and standalone diagnostics](#).

**Note:** When attempting to load diagnostics on a partition from partition standby, the device from which you are loading standalone diagnostics must be made available to the partition that is not able to load the operating system, if it is not already in that partition. Contact the customer or system administrator if a device must be moved between partitions in order to load standalone diagnostics.

Did standalone diagnostics load and start successfully?

- ◆ Yes: Go to step [8](#).
  - ◆ No: Go to step [14](#).
8. Was the intended boot device present in the output of the Display Configuration and Resource List option (which is run from the Task Selection menu)?
    - ◆ Yes: Continue with the next step.
    - ◆ No: Go to step [10](#).
  9. Did running diagnostics against the intended boot device result in a "No Trouble Found" message?
    - ◆ Yes: Go to step [12](#).
    - ◆ No: Go to the [List of service request numbers](#) and perform the repair actions for the SRN reported by the diagnostics. When you have completed the repair actions, go to step [13](#).
  10. Perform the following actions:
    - a. Perform the first item in the [action list](#) below. In the list of actions below, choose SCSI or IDE based on the type of device from which you are trying to boot the operating system.
    - b. Restart the system or partition.
    - c. Stop at the SMS menus and select Select Boot Options.
    - d. Is the device that was not appearing previously in the boot list now present?
      - ◇ Yes: Go to [MAP 0410: Repair checkout](#). This ends the procedure.
      - ◇ No: Perform the next item in the [action list](#) and then return to step [10.b](#). If there are no more items in the action list, go to step [11](#).

**Action list:**

**Note:** See [Finding part locations](#) for part numbers and links to exchange procedures.

- a. Verify that the SCSI or IDE cables are properly connected. Also verify that the device configuration and address jumpers are set correctly.
  - b. Do one of the following:
    - ◇ **SCSI boot device:** If you are attempting to boot from a SCSI device, remove all hot-swap disk drives (except the intended boot device, if the boot device is a hot-swap drive). If the boot device is present in the boot list after you boot the system to the SMS menus, add the hot-swap disk drives back in one at a time, until you isolate the failing device.
    - ◇ **IDE boot device:** If you are attempting to boot from an IDE device, disconnect all other internal SCSI or IDE devices. If the boot device is present in the boot list after you boot the system to the SMS menus, reconnect the internal SCSI or IDE devices one at a time, until you isolate the failing device or cable.
  - c. Replace the SCSI or IDE cables.
  - d. Replace the SCSI backplane (or IDE backplane, if present) to which the boot device is connected.
  - e. Replace the intended boot device.
  - f. Replace the system backplane.
11. Choose from the following:
    - ◆ If the intended boot device is not listed, go to [Processor and Subsystem Problem Isolation](#). This ends the procedure.
    - ◆ If an SRN is reported by the diagnostics, go to [List of service request numbers](#) and follow the action listed. This ends the procedure.
  12. Have you disconnected any other devices?
    - ◆ Yes: Reinstall each device that you disconnected, one at a time. After you reinstall each device, reboot the system. Continue this procedure until you isolate the failing device. Replace the failing device, then go to step [13](#).



- ◆ No: Perform an operating system-specific recovery process or reinstall the operating system. This ends the procedure.
13. Is the problem corrected?
- ◆ Yes: Go to [MAP 0410: Repair checkout](#). This ends the procedure.
  - ◆ No: If replacing the indicated FRUs did not correct the problem, or if the previous steps did not address your situation, go to [PFW1548: Processor subsystem problem isolation](#). This ends the procedure.
14. Is a SCSI boot failure (where you cannot boot from a SCSI-attached device) also occurring?
- ◆ Yes: Go to [PFW1548: Processor subsystem problem isolation](#). This ends the procedure.
  - ◆ No: Continue to the next step.
15. Perform the following actions to determine if another adapter is causing the problem:
- a. Remove all adapters except the one to which the optical drive is attached and the one used for the console.
  - b. Reload the standalone diagnostics. Can you successfully reload the standalone diagnostics?
    - ◇ Yes: Perform the following:
      - i. Reinstall the adapters that you removed (and attach devices as applicable) one at a time. After you reinstall each adapter, retry the boot operation until the problem reoccurs.
      - ii. Replace the adapter or device that caused the problem.
      - iii. Go to [MAP 0410: Repair checkout](#). This ends the procedure.
    - ◇ No: Continue with the next step.
16. The graphics adapter (if installed), optical drive, IDE or SCSI cable, or system board is most likely defective. Does your system have a PCI graphics adapter installed?
- ◆ Yes: Continue with the next step.
  - ◆ No: Go to step [18](#)
17. Perform the following to determine if the graphics adapter is causing the problem:
- a. Remove the graphics adapter.
  - b. Attach a TTY terminal to the system port.
  - c. Try to reload standalone diagnostics. Do the standalone diagnostics load successfully?
    - ◇ Yes: Replace the graphics adapter. This ends the procedure.
    - ◇ No: Continue with the next step.
18. Replace the following (if not already replaced), one at a time, until the problem is resolved:
- a. Optical drive
  - b. IDE or SCSI cable that goes to the optical drive
  - c. System board that contains the integrated SCSI or IDE adapters.
- If this resolves the problem, go to [MAP 0410: Repair Checkout](#). If the problem still persists or if the previous descriptions did not address your particular situation, go to [PFW1548: Processor subsystem problem isolation](#).

This ends the procedure.

- [PFW1540: Problem isolation procedures](#)

The PFW1540 procedures are used to locate problems in the processor subsystem or I/O subsystem(s).

- [PFW1542: I/O Problem Isolation Procedure](#)

This I/O problem-determination procedure isolates I/O card and I/O subsystem failures. When I/O problem isolation is complete, all cables and cards that are failing will have been replaced or reseated.

- [PFW1543: Model ESCALA PL 3250R and model ESCALA PL 6450R MCM problem isolation procedure](#)

Use this procedure to locate defective FRUs not found by normal diagnostics.

- [PFW1546: Model ESCALA PL 3250R and model ESCALA PL 6450R memory problem isolation procedure](#)

Use this procedure to locate defective FRUs not found by normal diagnostics.

- [PFW1548: Memory and processor subsystem problem isolation procedure](#)

Parent topic: [Analyzing problems](#)

---

## PFW1540: Problem isolation procedures

The PFW1540 procedures are used to locate problems in the processor subsystem or I/O subsystem(s).

If a problem is detected, these procedures help you isolate the problem to a failing unit. Find the symptom in the following table; then follow the instructions given in the Action column.

| Problem Isolation Procedures                                                                                                                                                                                                                 |                                                                                                                     |
|----------------------------------------------------------------------------------------------------------------------------------------------------------------------------------------------------------------------------------------------|---------------------------------------------------------------------------------------------------------------------|
| Symptom/Reference Code/Checkpoint                                                                                                                                                                                                            | Action                                                                                                              |
| You have or suspect an I/O card or I/O subsystem failure. You received one of the following SRNs or reference codes: 101-000, 101-517, 101-521, 101-538, 101-551 to 101-557, 101-559 to 101-599, 101-662, 101-727, 101-c32, 101-c33, 101-c70 | Go to <a href="#">PFW1542: I/O problem isolation procedure</a> .                                                    |
| The service processor on your Model ESCALA PL 3250R or Model 595 posts a failure and halts the IPL before the server firmware standby is reached. The server logs an error code indicating a problem with one of the MCMs.                   | Go to <a href="#">PFW1543: Model ESCALA PL 3250R and model ESCALA PL 6450R MCM problem isolation procedure</a> .    |
| The service processor on your Model ESCALA PL 3250R or Model 595 posts a failure and halts the IPL before the server firmware standby is reached. The server logs an error code indicating a memory subsystem failure.                       | Go to <a href="#">PFW1546: Model ESCALA PL 3250R and model ESCALA PL 6450R Memory problem isolation procedure</a> . |
| You have or suspect a memory or processor subsystem problem on a server other than a Model ESCALA PL 3250R or Model ESCALA PL 6450R. You received the following SRN or reference code: 101-185                                               | Go to <a href="#">PFW1548: Memory and Processor Problem Isolation Procedure</a> .                                   |
| If you were directed to the PFW1540 procedure by an SRN and that SRN is not listed in this table.                                                                                                                                            | Go to <a href="#">PFW1542: I/O problem isolation procedure</a> .                                                    |

## FRU identify LEDs

Your system is configured with an arrangement of LEDs that help identify various components of the system. These include but are not limited to:

- Rack identify beacon LED (optional rack status beacon)
- Processor subsystem drawer identify LED
- I/O drawer identify LED
- RIO port identify LED
- FRU identify LED
- Power subsystem FRUs
- Processor subsystem FRUs
- I/O subsystem FRUs
- I/O adapter identify LED
- DASD identify LED

The identify LEDs are arranged hierarchically with the FRU identify LED at the bottom of the hierarchy, followed by the corresponding processor subsystem or I/O drawer identify LED, and the corresponding rack identify LED to locate the failing FRU more easily. Any identify LED in the system may be flashed; refer to [Managing your server using the Advanced System Management Interface](#).

Any identify LED in the system may also be flashed by using the "Identify and Attention Indicators" task through the AIX diagnostic programs. The procedure to use the Identify and Attention Indicators task in the AIX diagnostics is outlined in "Tasks and Service Aids" in [Working with AIX diagnostics](#).

**Parent topic:** [Problems with loading and starting the operating system \(AIX and Linux\)](#)

## PFW1542: I/O Problem Isolation Procedure

This I/O problem-determination procedure isolates I/O card and I/O subsystem failures. When I/O problem isolation is complete, all cables and cards that are failing will have been replaced or reseated.

### Notes:

1. Be sure to unplug the power cords before removing or installing any part to avoid damage to it or the system or subsystem.
2. This MAP assumes that either:
  - ◆ An optical drive is installed and connected to the integrated EIDE adapter, and an AIX diagnostic CD-ROM is available.
  - OR
  - ◆ AIX standalone diagnostics can be booted from a NIM server.
3. If a power-on password or privileged-access password is set, you are prompted to enter the password before the AIX diagnostic CD-ROM can load.
4. The term POST indicators refers to the device mnemonics that appear during the power-on self-test (POST).
5. The service processor might have been set by the user to monitor system operations and to attempt recoveries. You might want to disable these options while you diagnose and service the system. If these settings are disabled, make notes of their current settings so that they can be restored before the system is turned back over to the customer.

The following settings may be of interest.

#### Monitoring

(also called surveillance) From the ASMI menu, expand the System Configuration menu, then click on Monitoring. Disable both types of surveillance.

#### Auto power restart

(also called unattended start mode) From the ASMI menu, expand Power/Restart Control, then click on Auto Power Restart, and set it to disabled.

#### Wake on LAN

From the ASMI menu, expand Wake on LAN, and set it to disabled. Call Out From the ASMI menu, expand the Service Aids menu, then click on Call-Home/Call-In Setup. Set the call-home system port and the call-in system port to disabled.

6. If this is a ESCALA PL Series system, verify that the system has not been set to boot to the SMS menus or to the open firmware prompt. From the ASMI menu, expand Power/Restart Control to view the menu, then click on Power On/Off System. The AIX/Linux partition mode boot should say "Continue to Operating System".

Select the model number you are servicing from the following list:

- [PFW1548-185: Processor subsystem problem isolation procedure for model ESCALA PL 245T/R](#)
- [PFW1548-505: Processor subsystem problem isolation procedure for model ESCALA PL 250R-VL or ESCALA PL 450R-XS with an HMC attached](#)
- [PFW1548-505: Processor subsystem problem isolation procedure for model ESCALA PL 250R-VL or ESCALA PL 450R-XS without an HMC attached](#)
- [PFW1548-510: Processor subsystem problem isolation procedure for model ESCALA PL 250R-L, ESCALA PL 250R-L+ or ESCALA PL 450R-VL+, with an HMC attached](#)
- [PFW1548-510: Processor subsystem problem isolation procedure for model ESCALA PL 250R-L, ESCALA PL 250R-L+ or ESCALA PL 450R-VL+, without an HMC attached](#)
- [PFW1542-520: I/O problem isolation procedure for model ESCALA PL 250T/R, ESCALA PL 250T/R+ or ESCALA PL 450T/R-L+,](#)
- [PFW1542-550: I/O problem isolation procedure for model ESCALA PL 450T/R, ESCALA PL 450T/R+ or ESCALA PL 850T/R-L+,](#)
- [PFW1542-570: I/O problem isolation procedure for model ESCALA PL 1650R-L+ and ESCALA PL 850R/PL 1650R/R+](#)
- [PFW1542-575: I/O problem isolation procedure for model 5/75](#)
- [PFW1542-590: I/O problem isolation procedure for model ESCALA PL 3250R, and5/95](#)

**Parent topic:** [Problems with loading and starting the operating system \(AIX and Linux\)](#)

## PFW1548-185: Processor subsystem problem isolation procedure for model 1/85 and ESCALA PL 245T/R

Use this problem isolation procedure to aid in solving memory, processor, and I/O problems on model 1/85 and ESCALA PL 245T/R.

- PFW1548-185-1a
  1. Insure that the diagnostics and the operating system are shut down.
  2. Power on the system.
  3. Insert the AIX diagnostic CD-ROM into the optical drive.

**Note:** If you cannot insert the diagnostic CD-ROM, go to [PFW1548-185-2a](#)

4. When the keyboard indicator is displayed on the system console:
  - ◇ On an ASCII terminal or directly-attached keyboard, press the number 5 key.
5. If you are prompted to do so, enter the appropriate password.

**Is the "Please define the System Console" screen displayed?**

NO

Go to step [PFW1548-185-2a](#).

YES

Go to step [PFW1548-185-17a](#)

- PFW1548-185-2a

**Note:** Ask the customer to identify the firmware console, which is the device that displays the system management services (SMS) menus.

- ◆ If system port 1 is the firmware console, leave the cable attached to system port 1 (as noted in step 2).
- ◆ If a graphics adapter is the firmware console, you will remove this adapter in step 4.

Removing the graphics adapter will start the selection routine of the firmware console. Ask the customer to attach an ASCII terminal to system port 1, or use your service provider console to simulate an ASCII terminal. If neither of these is an option, watch the operator panel for system reference code (SRC) AA00E1A9, which indicates that the firmware is displaying the SMS main menu.

1. Remove the power cords.
2. Disconnect all external cables (parallel, system port 2, keyboard, mouse, Ethernet on the system backplane, and so on), except the serial cable on system port 1, if present.
3. Remove the service access cover, or place the system, into the service position and remove the service access cover.
4. Record the slot numbers of the PCI adapters. Label and record the locations of all cables attached to the adapters. Disconnect all cables attached to the adapters and remove all of the adapters.
5. Disconnect all of the power and signal cables from the media drives located in the media bay.
6. Remove the media drives.
7. Record the slot numbers of the memory DIMMs on the system backplane. Remove all memory DIMMs except for one pair from the system backplane.

### Notes:

- a. Place the memory DIMM locking tabs in the locked (upright) position to prevent damage to the tabs.
- b. Memory DIMMs must be installed in pairs and in the correct connectors. Refer to [Install model 1/85 and ESCALA PL 245T/R memory modules](#) for plugging rules.

8. Disconnect the IDE cable from the IDE connector on the system backplane.
9. Disconnect the signal and power connectors from the disk drives. Disconnect the SCSI signal cable from the system backplane.
10. Plug in the power cords and wait for 01 to display in the upper-left-hand corner of the control panel display.
11. Power on the system.

**Does the system stop with the SMS main menu on the firmware console and AA00E1A9 in the operator panel?**

NO

Go to step [PFW1548-185-6a](#).

YES

Go to step [PFW1548-185-3a](#)

- PFW1548-185-3a

**Were any memory DIMMs removed from the system backplane?**

NO

Go to step [PFW1548-185-8a](#).

YES

Go to step [PFW1548-185-4a](#)

- PFW1548-185-4a
  1. Turn off the power, and remove the power cords.
  2. Replug the memory DIMMs that were removed from the system backplane in step PFW1548-185-2a in their original locations.

**Notes:**

- a. Place the memory DIMM locking tabs in the locked (upright) position to prevent damage to the tabs.
  - b. Memory DIMMs must be installed in pairs and in the correct connectors. Refer to [Install model 1/85 and ESCALA PL 245T/R memory modules](#) for plugging rules.
3. Plug in the power cords and wait for 01 to display in the upper-left-hand corner of the control panel display.
  4. Power on the system.

**Does the system stop with the SMS main menu on the firmware console and AA00E1A9 in the operator panel?**

NO

A memory DIMM in the pair you just replaced in the system is defective. Turn off the power, remove the power cords, and exchange the memory DIMMs in that pair one at a time with new or previously removed memory DIMMs. Repeat this step until the defective memory DIMM is identified, or all memory DIMMs have been exchanged.

If your symptom did not change and all the memory DIMMs have been exchanged, call your next level of support for assistance.

If the symptom changed, check for loose cards and obvious problems.

If you do not find a problem, go to the [Start-of-Call procedure](#) and follow the instructions for the new symptom.

YES

Go to step [PFW1548-185-8a](#)

- PFW1548-185-5a

This step is reserved.

- PFW1548-185-6a

One of the FRUs remaining in the system unit is defective.

**Note:** If a memory DIMM is exchanged, insure that the new memory DIMM is the same size and speed as the original memory DIMM.

1. Turn off the power, remove the power cords, and exchange the following FRUs in the order listed:
  - a. Memory DIMMs. Exchange one at a time with new or previously removed DIMMs.
  - b. System backplane, location Un-P1.
  - c. Power supply.
2. Plug in the power cords and wait for 01 to display in the upper-left-hand corner of the control panel display.
3. Power on the system.

**Does the system stop with the SMS main menu on the firmware console and AA00E1A9 in the operator panel?**

NO

Reinstall the original FRU. Repeat the FRU replacement steps until the defective FRU is identified or all the FRUs have been exchanged.

If the symptom did not change and all the FRUs have been exchanged, call your next level of support for assistance.

If the symptom has changed, check for loose cards, cables, and obvious problems.

If you do not find a problem, go to the [Start-of-Call procedure](#) and follow the instructions for the new symptom.

YES

Go to [MAP 0410: Repair Checkout](#).

- PFW1548-185-7a

This step is reserved.

- PFW1548-185-8a

1. Turn off the power.
2. Reconnect the system console.
  - a. If an ASCII terminal has been defined as the firmware console, attach the ASCII terminal cable to the S1 connector on the rear of the system unit.
  - b. If a display attached to a display adapter has been defined as the firmware console, install the display adapter and connect the display to the adapter. Plug the keyboard and mouse into the keyboard connector on the rear of the system unit.
3. Power on the system.
4. If the ASCII terminal or graphics display (including display adapter) is connected differently from the way it was previously, the console selection screen appears. Select a firmware console.
5. When the word keyboard is displayed, press the number 1 key on the directly attached keyboard, an ASCII terminal or HMC. This activates the system management services (SMS).
6. Enter the appropriate password if you are prompted to do so.

**Is the SMS screen displayed?**

NO

One of the FRUs remaining in the system unit is defective.

Exchange the FRUs that have not been exchanged, in the following order:

- a. Replace the system backplane, location Un-P1.
- b. If you are using a graphics display, go to the problem determination procedures for the display.
 

If you do not find a problem, do the following:

  - i. Replace the display adapter.
  - ii. Replace the backplane, location: Un-P1.

Repeat this step until the defective FRU is identified or all the FRUs have been exchanged.

If the symptom did not change and all the FRUs have been exchanged, call your next level of support for assistance.

If the symptom changed, check for loose cards and obvious problems.

If you do not find a problem, go to the [Start-of-Call procedure](#) and follow the instructions for the new symptom..

YES

Go to [PFW1548-185-9a](#).

- PFW1548-185-9a
  1. Make sure the diagnostic CD-ROM is inserted into the optical drive.
  2. Turn off the power and remove the power cords.
  3. Plug the IDE cable into the IDE connector on the system backplane.
  4. Connect the signal and power connectors to the IDE optical drive.
  5. Plug in the power cords and wait for 01 to display in the upper-left-hand corner of the control panel display.
  6. Power on the system.
  7. After the word keyboard is displayed, press the number 5 key on either the directly attached keyboard or an ASCII terminal keyboard.
  8. Enter the appropriate password if you are prompted to do so.

**Is the Please define the System Console screen displayed?**

NO

One of the FRUs remaining in the system unit is defective.

Exchange the FRUs that have not been exchanged, in the following order:

- a. IDE cable
- b. Optical drive
- c. System backplane, location: Un-P1

Repeat this step until the defective FRU is identified or all the FRUs have been exchanged.

If the symptom did not change and all the FRUs have been exchanged, call your next level of support for assistance.

If the symptom has changed, check for loose cards, cables, and obvious problems.

If you do not find a problem, go to the [Start-of-Call procedure](#) and follow the instructions for the new symptom.

YES

Go to [PFW1548-185-12a](#).

- PFW1548-185-10a

This step is reserved.

- PFW1548-185-11a

This step is reserved.

- PFW1548-185-12a

The system is working correctly with this configuration. One of the disk drives that you removed from the configuration may be defective.

1. Make sure the diagnostic CD-ROM is inserted into the optical drive.
2. Turn off the power and remove the power cords.
3. Reattach the SCSI signal cable to the system backplane if you have not already done so. Attach the power cable and the signal cable to a disk drive.
4. Plug in the power cords and wait for 01 to display in the upper-left-hand corner of the control panel display.
5. Power on the system.
6. After the word keyboard is displayed, press the number 5 key on either the directly attached keyboard or an ASCII terminal keyboard.
7. Enter the appropriate password if you are prompted to do so.

**Is the Please define the System Console screen displayed?**

NO

Exchange the FRUs that have not been exchanged, in the following order:

a. Last disk drive that was reconnected.

b. System backplane, location: Un-P1

Repeat this step until the defective FRU is identified or all the FRUs have been exchanged.

If the symptom did not change and all the FRUs have been exchanged, call your next level of support for assistance.

If the symptom has changed, check for loose cards, cables, and obvious problems.

If you do not find a problem, go to the [Start-of-Call procedure](#) and follow the instructions for the new symptom.

YES

Repeat this step with all disk drives that were installed in the system. Go to [PFW1548-185-14a](#).

- PFW1548-185-13a

This step is reserved.

- PFW1548-185-14a

The system is working correctly with this configuration. One of the devices that was disconnected from the system backplane may be defective.

1. Turn off the power and remove the power cords.
2. Attach a system backplane device (for example: parallel, system port 1, system port 2, system port 3, keyboard, mouse, Ethernet, or SCSI) that had been removed.
3. Plug in the power cords and wait for 01 to display in the upper-left-hand corner of the control panel display.
4. Power on the system.
5. If the Console Selection screen is displayed, choose the system console.
6. After the word keyboard displays, press the number 5 key on either the directly attached keyboard or on an ASCII terminal keyboard.
7. Enter the appropriate password if you are prompted to do so.

#### **Is the Please define the System Console screen displayed?**

NO

The last device or cable that you attached is defective.

To test each FRU, exchange the FRUs in the following order:

a. Device and cable (last one attached)

b. System backplane, location: Un-P1

If the symptom did not change and all the FRUs have been exchanged, call your next level of support for assistance.

If the symptom has changed, check for loose cards, cables, and obvious problems.

If you do not find a problem, go to the [Start-of-Call procedure](#) and follow the instructions for the new symptom. Go to [MAP 0410: Repair Checkout](#).

YES

Repeat this step until all of the devices are attached. Go to [PFW1548-185-15a](#).

- PFW1548-185-15a

The system is working correctly with this configuration. One of the PCI adapters that you removed may be defective.

1. Turn off the power and remove the power cords.
2. Install a FRU (adapter) and connect any cables and devices that were attached to the FRU.
3. Plug in the power cords and wait for OK prompt to display in the control panel display.
4. Power on the system.
5. If the Console Selection screen is displayed, choose the system console.
6. After the word keyboard displays, press the number 5 key on either the directly attached keyboard or on an ASCII terminal keyboard.
7. Enter the appropriate password if you are prompted to do so.

#### **Is the Please define the System Console screen displayed?**

NO



Go to [PFW1548-185-16a](#).

YES

Repeat this step until all of the FRUs (adapters) are installed. Go to [MAP 0410: Repair Checkout](#)

- PFW1548-185-16a

The last FRU installed or one of its attached devices is probably defective.

1. Make sure the diagnostic CD-ROM is inserted into the optical drive.
2. Turn off the power and remove the power cords.
3. Starting with the last installed adapter, disconnect one attached device and cable.
4. Plug in the power cords and wait for the "01" in the upper-left corner on the control panel display.
5. Power on the system.
6. If the Console Selection screen is displayed, choose the system console.
7. After the word keyboard displays, press the number 5 key on either the directly attached keyboard or on an ASCII terminal keyboard.
8. Enter the appropriate password if you are prompted to do so.

### Is the Please define the System Console screen displayed?

NO

Repeat this step until the defective device or cable is identified or all devices and cables have been disconnected.

If all the devices and cables have been removed, then one of the FRUs remaining in the system unit is defective.

To test each FRU, exchange the FRUs in the following order:

- a. Adapter (last one installed)
- b. System backplane, location Un-P1

If the symptom did not change and all the FRUs have been exchanged, call service support for assistance.

If the symptom has changed, check for loose cards, cables, and obvious problems.

If you do not find a problem, go to the [Start-of-call procedure](#) and follow the instructions for the new symptom.

YES

The last device or cable that you disconnected is defective. Exchange the defective device or cable. Go to [MAP 0410: Repair Checkout](#).

- PFW1548-185-17a

1. Follow the instructions on the screen to select the system console.
2. When the DIAGNOSTIC OPERATING INSTRUCTIONS screen is displayed, press Enter.
3. Select Advanced Diagnostics Routines.
4. If the terminal type has not been defined, you must use the initialize terminal option on the FUNCTION SELECTION menu to initialize the AIX diagnostic environment before you can continue with the diagnostics. This is a separate operation from selecting the console display.
5. If the NEW RESOURCE screen is displayed, select an option from the bottom of the screen.

**Note:** Adapters and devices that require supplemental media are not shown in the new resource list. If the system has adapters or devices that require supplemental media, select option 1.

6. When the DIAGNOSTIC MODE SELECTION screen is displayed, press Enter.
7. Select All Resources. (If you were sent here from PFW1548-185-21a, select the adapter or device that was loaded from the supplemental media).

### Did you get an SRN?

NO

Go to [PFW1548-185-19a](#).

YES

Go to [PFW1548-185-18a](#).

- PFW1548-185-18a

Look at the FRU part numbers associated with the SRN.

**Have you exchanged all the FRUs that correspond to the failing function codes (FFCs)?**

NO

Exchange the FRU with the highest failure percentage that has not been changed. Repeat this step until all the FRUs associated with the SRN have been exchanged or diagnostics run with no trouble found. Run diagnostics after each FRU is exchanged. Go to [MAP 0410: Repair Checkout](#).

YES

If the symptom did not change and all the FRUs have been exchanged, call service support for assistance.

- PFW1548-185-19a

**Does the system have adapters or devices that require supplemental media?**

NO

Go to [PFW1548-185-20a](#).

YES

Go to [PFW1548-185-21a](#).

- PFW1548-185-20a

Consult the PCI adapter configuration documentation for your operating system to verify that all adapters are configured correctly. Go to [MAP 0410: Repair Checkout](#).

If the symptom did not change and all the FRUs have been exchanged, call service support for assistance.

- PFW1548-185-21a
  1. Select Task Selection.
  2. Select Process Supplemental Media and follow the on screen instructions to process the media. Supplemental media must be loaded and processed one at a time.

**Did the system return to the TASKS SELECTION SCREEN after the supplemental media was processed?**

NO

Go to [PFW1548-185-22a](#).

YES

Press F3 to return to the FUNCTION SELECTION screen. Go to [step 4](#).

- PFW1548-185-22a

The adapter or device is probably defective.

If the supplemental media is for an adapter, replace the FRUs in the following order:

1. Adapter
2. System backplane, location Un-P1

If the supplemental media is for a device, replace the FRUs in the following order:

1. Device and any associated cables
2. The adapter to which the device is attached

Repeat this step until the defective FRU is identified or all the FRUs have been exchanged.

If the symptom did not change and all the FRUs have been exchanged, call service support for assistance.

If the symptom has changed, check for loose cards, cables, and obvious problems.

If you do not find a problem, go to the [Start-of-Call procedure](#) and follow the instructions for the new symptom. Go to [MAP 0410: Repair Checkout](#).

End of procedure.

---

## **PFW1548-505: Processor subsystem problem isolation procedure for model ESCALA PL 250R-VL or ESCALA PL 450R-XS with an HMC attached**

Use this problem isolation procedure to aid in solving memory and processor problems on ESCALA PL 250R-VL or ESCALA PL 450R-XS attached to an HMC.

- PFW1548-505-1

1. Insure that the diagnostics and the operating system are shut down.

**Is the system at "service processor standby", indicated by "01" in the control panel?**

NO

Replace the system backplane, location: Un-P1. Return to the beginning of this step.

YES

Continue with substep 2.

2. Turn on the power using either the white button or the HMC.

**Does the managed system reach "service processor standby" indicated by "01" in the control panel?**

NO

Go to step [PFW1548-505-3](#).

YES

Go to step [PFW1548-505-2](#).

- PFW1548-505-2

1. Insert the diagnostic CD-ROM into the optical drive.

**Note:** If you cannot insert the diagnostic CD-ROM, go to [PFW1548-505-3](#).

2. Turn on the power using either the HMC or the white button. (If the diagnostic CD-ROM is not in the optical drive, insert it now.) After the system has reached hypervisor standby, activate a Linux or AIX partition by clicking on the "Advanced" button on the activation screen. On the "advanced" activation screen, select "boot in service mode using the default boot list" to boot the diagnostic CD-ROM.
3. If you are prompted to do so, enter the appropriate password.

**Is the "Please define the System Console" screen displayed?**

NO

Go to step [PFW1548-505-3](#).

YES

Go to step [PFW1548-505-21](#).

- PFW1548-505-3

1. Turn off the power.
2. If you have not already done so, configure the service processor (using the ASMI menus) with the instructions in note 6 at the beginning of this procedure, then return here and continue.
3. Exit the service processor (ASMI) menus and remove the power cords.
4. Disconnect all external cables (parallel, system port 1, system port 2, keyboard, mouse, Ethernet on the system planar, Ethernet on the service processor if present, and so on). Leave the Ethernet cable between the service processor and the HMC attached.
5. Place the drawer into the service position and remove the service access cover.
6. Record the slot numbers of the PCI adapters. Label and record the locations of all cables attached to the adapters. Disconnect all cables attached to the adapters and remove all of the adapters.
7. Disconnect all of the power and signal cables from the media drives located in media bay.
8. Remove the media drives.
9. Record the slot numbers of the memory DIMMs on the system backplane. Remove all memory DIMMs except for one pair from the system backplane.

**Notes:**

- a. Place the memory DIMM locking tabs in the locked (upright) position to prevent damage to the tabs.
- b. Memory DIMMs must be installed in pairs and in the correct connectors. Refer to the memory DIMM section of [Locations-Model ESCALA PL 250R-VL or ESCALA PL 450R-XS](#) for information on memory DIMMs.

10. Disconnect the IDE cable from the IDE connector on the system backplane.
11. Disconnect the signal and power connectors from both disk drive backplanes.
12. Disconnect the disk drives (if present) from the disk drive backplane.
13. Plug in the power cords and wait for "01" in the upper-left corner of the control panel display.
14. Turn on the power using either the HMC or the white button. (If the diagnostic CD-ROM is not in the optical drive, insert it now.) After the system has reached hypervisor standby, activate a Linux or AIX partition by clicking on the "Advanced" button on the activation screen. On the "advanced" activation screen, select "boot in service mode using the default boot list" to boot the diagnostic CD-ROM.

**Does the system stop with B1xxF22A, CA00E1F2, CA00E1F3, or STBY displayed on the control panel?**

NO

Go to [PFW1548-505-7](#).

YES

Go to [PFW1548-505-4](#).

- PFW1548-505-4

**Were any memory DIMMs removed from the system backplane?**

NO

Go to [PFW1548-505-9](#).

YES

Go to [PFW1548-505-5](#).

- PFW1548-505-5
  1. Turn off the power, and remove the power cords.
  2. Replug the memory DIMMs that were removed from the system backplane in [PFW1548-505-2](#) in their original locations.

#### Notes:

- a. Place the memory DIMM locking tabs into the locked (upright) position to prevent damage to the tabs.
  - b. Memory DIMMs must be installed in pairs in the correct connectors. Refer to [Memory DIMM locations](#) for information on memory DIMMs.
3. Plug in the power cords and wait for "01" in the control panel display.
  4. Turn on the power using either the HMC or the white button. (If the diagnostic CD-ROM is not in the optical drive, insert it now.) After the system has reached hypervisor standby, activate a Linux or AIX partition by clicking on the "Advanced" button on the activation screen. On the "advanced" activation screen, select "boot in service mode using the default boot list" to boot the diagnostic CD-ROM.
  5. If you are prompted to do so, enter the appropriate password.

**Does the system stop with B1xxF22A, CA00E1F2, CA00E1F3, or STBY displayed on the control panel?**

NO

A memory DIMM in the pair you just replaced in the system is defective. Turn off the power, remove the power cords, and exchange the memory DIMMs in that pair one at a time with new or previously removed memory DIMMs. Repeat this step until the defective memory DIMM is identified, or all memory DIMMs have been exchanged.

If your symptom did not change and all the memory DIMMs have been exchanged, call your service support person for assistance.

If the symptom changed, check for loose cards and obvious problems.

If you do not find a problem, go to the [Start-of-call procedure](#) and follow the instructions for the new symptom.

YES

Go to [PFW1548-505-9](#).

- PFW1548-505-6

This step is reserved.

- PFW1548-505-7

One of the FRUs remaining in the system unit is defective.

**Note:** If a memory DIMM is exchanged, insure that the new memory DIMM is the same size and speed as the original memory DIMM.

1. Turn off the power, remove the power cords, and exchange the following FRUs in the order listed:
  - a. Memory DIMMs. Exchange one at a time with new or previously removed DIMMs
  - b. System backplane, location UN-P1
  - c. Power supplies.
2. Plug in the power cords and wait for "01" in the upper-left corner of the control panel display.
3. Turn on the power using either the HMC or the white button. (If the diagnostic CD-ROM is not in the optical drive, insert it now.) After the system has reached hypervisor standby, activate a Linux or AIX partition by clicking on the "Advanced" button on the activation screen. On the "advanced" activation screen, select "boot in service mode using the default boot list" to boot the diagnostic CD-ROM.

**Does the system stop with B1xxF22A, CA00E1F2, CA00E1F3, or STBY displayed on the control panel?**

NO

Reinstall the original FRU. Repeat the FRU replacement steps until the defective FRU is identified or all the FRUs have been exchanged.

If the symptom did not change and all the FRUs have been exchanged, call service support for assistance.

If the symptom has changed, check for loose cards, cables, and obvious problems.

If you do not find a problem, go to the [Start of call procedure](#) and follow the instructions for the new symptom.

YES

Go to [MAP 0410: Repair checkout](#).

- PFW1548-505-8

This step is reserved.

- PFW1548-505-9

1. Turn off the power.
2. Reconnect the system console.

**Notes:**

- a. If an ASCII terminal has been defined as the firmware console, attach the ASCII terminal cable to the S1 connector on the rear of the system unit.
  - b. If a display attached to a display adapter has been defined as the firmware console, install the display adapter and connect the display to the adapter. Plug the keyboard and mouse into the keyboard connector on the rear of the system unit.
3. Turn on the power using either the HMC or the white button. (If the diagnostic CD-ROM is not in the optical drive, insert it now.) After the system has reached hypervisor standby, activate a Linux or AIX partition by clicking on the "Advanced" button on the activation screen. On the "advanced" activation screen, select "boot in service mode using the default boot list" to boot the diagnostic CD-ROM.
  4. If the ASCII terminal or graphics display (including display adapter) is connected differently from the way it was previously, the console selection screen appears. Select a firmware console.
  5. When the word keyboard is displayed, press the number 1 key on the directly attached keyboard, an ASCII terminal or HMC. This activates the system management services (SMS).
  6. Enter the appropriate password if you are prompted to do so.

**Is the SMS screen displayed?**

NO

One of the FRUs remaining in the system unit is defective.

Exchange the FRUs that have not been exchanged, in the following order:

1. Replace the service processor, location Un-P1.
2. If you are using a graphics display, go to the problem determination procedures for the display.

If you do not find a problem, do the following:

- Replace the display adapter.
- Replace the backplane in which the graphics adapter is plugged.

Repeat this step until the defective FRU is identified or all the FRUs have been exchanged.

If the symptom did not change and all the FRUs have been exchanged, call service support for assistance.

If the symptom changed, check for loose cards, cables, and obvious problems.

If you do not find a problem, go to the [Start of call procedure](#) and follow the instructions for the new symptom.

YES

Go to [PFW1548-505-10](#).

• PFW1548-505-10

1. Make sure the diagnostic CD-ROM is inserted into the optical drive.
2. Turn off the power and remove the power cords.
3. Plug the IDE cable into the IDE connector on the system backplane.
4. Connect the signal and power connectors to the IDE optical drive.
5. Plug in the power cords and wait for "01" in the upper-left corner of the control panel display.
6. Turn on the power using either the HMC or the white button. (If the diagnostic CD-ROM is not in the optical drive, insert it now.) After the system has reached hypervisor standby, activate a Linux or AIX partition by clicking on the "Advanced" button on the activation screen. On the "advanced" activation screen, select "boot in service mode using the default boot list" to boot the diagnostic CD-ROM.
7. After the word keyboard is displayed, press the number 5 key on either the directly attached keyboard or an ASCII terminal keyboard.
8. Enter the appropriate password if you are prompted to do so.

**Is the Please define the System Console screen displayed?**

NO

One of the FRUs remaining in the system unit is defective.

Exchange the FRUs that have not been exchanged, in the following order:

1. IDE cable
2. Optical drive
3. System backplane, location Un-P1

Repeat this step until the defective FRU is identified or all the FRUs have been exchanged.

If the symptom did not change and all the FRUs have been exchanged, call service support for assistance.

If the symptom has changed, check for loose cards, cables, and obvious problems.

If you do not find a problem, go to the [Start of call procedure](#) and follow the instructions for the new symptom.

YES

Go to [PFW1548-505-11](#).

• PFW1548-505-11

The system is working correctly with this configuration. One of the SCSI devices that was disconnected may be defective.

1. Make sure the diagnostic CD-ROM is inserted into the optical drive.
2. Turn off the power and remove the power cords.

3. Install a disk drive in a disk drive backplane.
4. Plug the power cords and wait for "01" on the control panel display.
5. Turn on the power using either the HMC or the white button. (If the diagnostic CD-ROM is not in the optical drive, insert it now.) After the system has reached hypervisor standby, activate a Linux or AIX partition by clicking on the "Advanced" button on the activation screen. On the "advanced" activation screen, select "boot in service mode using the default boot list" to boot the diagnostic CD-ROM.
6. After the word keyboard is displayed, press the number 5 key on either the directly attached keyboard or on an ASCII terminal keyboard.
7. Enter the appropriate password if you are prompted to do so.

**Is the Please define the System Console screen displayed?**

NO

Exchange the FRUs that have not been exchanged, in the following order:

1. Last disk drive installed
2. System backplane, location Un-P1 (Since the disk drive backplane is not a separate FRU)

Repeat this step until the defective FRU is identified or all the FRUs have been exchanged.

If the symptom did not change and all the FRUs have been exchanged, call service support for assistance.

If the symptom has changed, check for loose cards, cables, and obvious problems.

If you do not find a problem, go to the [Start of call procedure](#) and follow the instructions for the new symptom.

YES

Repeat this step with all disk drives that were installed in the disk drive backplane. Go to [PFW1548-505-12](#).

- PFW1548-505-12

This step is reserved.

- PFW1548-505-13

The system is working correctly with this configuration. One of the disk drive backplanes may be defective.

1. Turn off the power and remove the power cords.
2. Attach a system backplane device (for example: parallel, system port 1, system port 2, Ethernet, SCSI, keyboard or mouse) that had been removed.
3. Plug in the power cords and wait for "01" in the upper-left corner on the control panel display.
4. Turn on the power using either the HMC or the white button. (If the diagnostic CD-ROM is not in the optical drive, insert it now.) After the system has reached hypervisor standby, activate a Linux or AIX partition by clicking on the "Advanced" button on the activation screen. On the "advanced" activation screen, select "boot in service mode using the default boot list" to boot the diagnostic CD-ROM.
5. If the Console Selection screen is displayed, choose the system console.
6. After the word keyboard is displayed, press the number 5 key on either the directly attached keyboard or an ASCII terminal keyboard.
7. Enter the appropriate password if you are prompted to do so.

**Is the Please define the System Console screen displayed?**

NO

The last device or cable that you attached is defective. To test each FRU, exchange the FRUs in the following order:

1. Device and cable (last one attached)
2. System backplane

If the symptom did not change and all the FRUs have been exchanged, call service support for assistance.

If the symptom has changed, check for loose cards, cables, and obvious problems.

If you do not find a problem, go to the [Start of call procedure](#) and follow the instructions for the new symptom. Go to [MAP 0410: Repair checkout](#).

YES

Repeat this step until all of the devices are attached. Go to step [PFW1548-505-14](#).

- PFW1548-505-14

The system is working correctly with this configuration. One of the disk drives that you removed from the disk drive backplanes may be defective.

1. Turn off the power and remove the power cords.
2. Install a FRU (adapter) and connect any cables and devices that were attached to the FRU.
3. Plug in the power cords and wait for the OK prompt to display on the control panel display.
4. Turn on the power using either the HMC or the white button. (If the diagnostic CD-ROM is not in the optical drive, insert it now.) After the system has reached hypervisor standby, activate a Linux or AIX partition by clicking on the "Advanced" button on the activation screen. On the "advanced" activation screen, select "boot in service mode using the default boot list" to boot the diagnostic CD-ROM.
5. If the Console Selection screen is displayed, choose the system console.
6. After the word keyboard displays, press the number 5 key on either the directly attached keyboard, virtual terminal on the HMC, or an ASCII terminal.
7. Enter the appropriate password if you are prompted to do so.

**Is the Please define the System Console screen displayed?**

NO

Go to step [PFW1548-505-15](#).

YES

Repeat this step until all of the FRUs (adapters) are installed. Go to [MAP 0410: Repair checkout](#).

- PFW1548-505-15

The last FRU installed or one of its attached devices is probably defective.

1. Make sure the diagnostic CD-ROM is inserted into the optical drive.
2. Turn off the power and remove the power cords.
3. Starting with the last installed adapter, disconnect one attached device and cable.
4. Plug in the power cords and wait for "01" in the upper-left corner of the control panel display.
5. Turn on the power using either the HMC or the white button. (If the diagnostic CD-ROM is not in the optical drive, insert it now.) After the system has reached hypervisor standby, activate a Linux or AIX partition by clicking on the "Advanced" button on the activation screen. On the "advanced" activation screen, select "boot in service mode using the default boot list" to boot the diagnostic CD-ROM.
6. If the Console Selection screen is displayed, choose the system console.
7. After the word keyboard displays, press the number 5 key on either the directly attached keyboard, virtual terminal on the HMC, or an ASCII terminal.
8. Enter the appropriate password if you are prompted to do so.

**Is the Please define the System Console screen displayed?**

NO

Repeat this step until the defective device or cable is identified or all devices and cables have been disconnected.

If all the devices and cables have been removed, then one of the FRUs remaining in the system unit is defective.

To test each FRU, exchange the FRUs in the following order:

1. Adapter (the last one installed)
2. PCI backplane, Un-P2
3. System backplane, Un-P1

If the symptom did not change and all the FRUs have been exchanged, call service support for assistance.

If the symptom has changed, check for loose cards, cables, and obvious problems.

If you do not find a problem return, go to the [Start of call procedure](#) and follow the instructions for the new symptom.

YES

The last device or cable that you disconnected is defective. Exchange the defective device or cable. Go to [MAP 0410: Repair checkout](#).

- PFW1548-505-16



The system is working correctly with this configuration. One of the devices that was disconnected from the system backplane may be defective.

1. Follow the instructions on the screen to select the system console.
2. When the DIAGNOSTIC OPERATING INSTRUCTIONS screen is displayed, press Enter.
3. Select Advanced Diagnostics Routines.
4. If the terminal type has not been defined, you must use the initialize terminal option on the FUNCTION SELECTION menu to initialize the AIX diagnostic environment before you can continue with the diagnostics. This is a separate operation from selecting the console display.
5. If the NEW RESOURCE screen is displayed, select an option from the bottom of the screen.

**Note:** Adapters and devices that require supplemental media are not shown in the new resource list. If the system has adapters or devices that require supplemental media, select option 1.

6. When the DIAGNOSTIC MODE SELECTION screen is displayed, press Enter.
7. Select All Resources. (If you were sent here from step PFW1548-505-20, select the adapter or device that was loaded from the supplemental media).

#### **Did you get an SRN?**

NO

Go to step [PFW1548-505-18](#).

YES

Go to [PFW1548-505-17](#).

- PFW1548-505-17

Look at the FRU part numbers associated with the SRN

#### **Have you exchanged all the FRUs that correspond to the failing function codes (FFCs)?**

NO

Exchange the FRU with the highest failure percentage that has not been changed.

Repeat this step until all the FRUs associated with the SRN have been exchanged or diagnostics run with no trouble found. Run diagnostics after each FRU is exchanged. Go to [MAP 0410: Repair checkout](#).

YES

If the symptom did not change and all the FRUs have been exchanged, call service support for assistance.

- PFW1548-505-18

#### **Does the system have adapters or devices that require supplemental media?**

NO

Go to step [PFW1548-505-19](#).

YES

Go to step [PFW1548-505-20](#).

- PFW1548-505-19

Consult the PCI adapter configuration documentation for your operating system to verify that all adapters are configured correctly. Go to [MAP 0410: Repair Checkout](#).

If the symptom did not change and all the FRUs have been exchanged, call service support for assistance.

- PFW1548-505-20

1. Select Task Selection.

2. Select Process Supplemental Media and follow the on screen instructions to process the media. Supplemental media must be loaded and processed one at a time.

#### **Did the system return to the TASKS SELECTION SCREEN after the supplemental media was processed?**

NO

Go to [PFW1548-505-21](#).

YES

Press F3 to return to the FUNCTION SELECTION screen. Go to [4](#).

- PFW1548-505-21

The adapter or device is probably defective.

If the supplemental media is for an adapter, replace the FRUs in the following order:

1. Adapter
2. PCI backplane, Un-P2.
3. System backplane, Un-P1.

If the supplemental media is for a device, replace the FRUs in the following order:

1. Device and any associated cables
2. The adapter to which the device is attached

Repeat this step until the defective FRU is identified or all the FRUs have been exchanged.

If the symptom did not change and all the FRUs have been exchanged, call service support for assistance.

If the symptom has changed, check for loose cards, cables, and obvious problems.

If you do not find a problem, go to the [Start of call procedure](#) and follow the instructions for the new symptom. Go to [MAP 0410: Repair checkout](#).

End of procedure.

---

## PFW1548-505: Processor subsystem problem isolation procedure for model ESCALA PL 250R-VL or ESCALA PL 450R-XS without an HMC attached

Use this problem isolation procedure to aid in solving memory and processor problems on ESCALA PL 250R-VL or ESCALA PL 450R-XS that is not attached to an HMC.

- PFW1548-505-1a
  1. Insure that the diagnostics and the operating system(s) are shut down.
  2. Turn on the power.
  3. Insert the AIX diagnostic CD-ROM into the optical drive.

**Note:** If you cannot insert the diagnostic CD-ROM, go to [PFW1548-505-2a](#).

4. When the keyboard indicator is displayed on the system console:
  - ◇ On an ASCII terminal or directly-attached keyboard, press the number 5 key.
5. If you are prompted to do so, enter the appropriate password.

### Is the "Please define the System Console" screen displayed?

NO

Go to step [PFW1548-505-2a](#).

YES

Go to step [PFW1548-505-17a](#).

- PFW1548-505-2a
  1. Turn on the power.
  2. If you have not already done so, configure the service processor (using the ASMI menus) with the instructions in [note6](#) at the beginning of this MAP, then return here and continue.
  3. Exit the service processor (ASMI) menus and remove the power cords.
  4. Disconnect all external cables (parallel, system port 1, system port 2, keyboard, mouse, Ethernet on the system planar, Ethernet on the service processor if present, and so on).
  5. Remove the service access cover (model xxx), or place the drawer (model yyy), into the service position and remove the service access cover.
  6. Record the slot numbers of the PCI adapters. Label and record the locations of all cables attached to the adapters. Disconnect all cables attached to the adapters and remove all of the

adapters.

7. Disconnect all of the power and signal cables from the media drives located in the media bay.
8. Remove the media drives.
9. Record the slot numbers of the memory DIMMs on the system backplane. Remove all memory DIMMs except for one pair from the system backplane.

**Notes:**

- a. Place the memory DIMM locking tabs in the locked (upright) position to prevent damage to the tabs.
- b. Memory DIMMs must be installed in pairs and in the correct connectors. Refer to [Locations](#) [model ESCALA PL 250R-VL](#) or [ESCALA PL 450R-XS](#) for information on memory DIMMs.

10. Disconnect the IDE cable from the IDE connector on the system backplane.
11. Disconnect the signal and power connectors from both disk drive backplanes.
12. Disconnect the disk drives (if present) from both disk drive backplanes.
13. Plug in the power cords and wait for "01" in the upper-left-hand corner of the control panel display.
14. Turn on the power.

**Does the system stop with B1xxF22A, CA00E1F2, CA00E1F3, or STBY displayed on the control panel?**

NO

Go to step [PFW1548-505-6a](#).

YES

Go to step [PFW1548-505-3a](#).

- [PFW1548-505-3a](#)

**Were any memory DIMMs removed from the system backplane?**

NO

Go to step [PFW1548-505-8a](#).

YES

Go to step [PFW1548-505-4a](#).

- [PFW1548-505-4a](#)
  1. Turn off the power, and remove the power cords.
  2. Replug the memory DIMMs that were removed from the system backplane in step [PFW1548-505-2a](#) in their original locations.

**Notes:**

- a. Place the memory DIMM locking tabs into the locked (upright) position to prevent damage to the tabs.
- b. Memory DIMMs must be installed in pairs in the correct connectors. Refer to [Locations](#) [model ESCALA PL 250R-VL](#) or [ESCALA PL 450R-XS](#) for information on memory DIMMs.

3. Plug in the power cords and wait for "01" in the control panel display.
4. Turn on the power.

**Does the system stop with B1xxF22A, CA00E1F2, CA00E1F3, or STBY displayed on the control panel?**

NO

A memory DIMM in the pair you just replaced in the system is defective. Turn off the power, remove the power cords, and exchange the memory DIMMs in that pair one at a time with new or previously removed memory DIMMs. Repeat this step until the defective memory DIMM is identified, or all memory DIMMs have been exchanged.

If your symptom did not change and all the memory DIMMs have been exchanged, call your service support person for assistance.

If the symptom changed, check for loose cards and obvious problems.

If you do not find a problem, go to the [Start-of-Call MAP](#) and follow the instructions for the new symptom.

YES

Go to [PFW1548-505-8a](#).

- PFW1548-505-5a

This step is reserved.

- PFW1548-505-6a

One of the FRUs remaining in the system unit is defective.

**Note:** If a memory DIMM is exchanged, insure that the new memory DIMM is the same size and speed as the original memory DIMM.

1. Turn off the power, remove the power cords, and exchange the following FRUs in the order listed:
  - a. Memory DIMMs. Exchange one at a time with new or previously removed DIMMs
  - b. System backplane, location Un-P1.
  - c. Power supplies.
2. Plug in the power cords and wait for "01" in the upper-left corner of the control panel display.
3. Turn on the power.

**Does the system stop with B1xxF22A, CA00E1F2, CA00E1F3, or STBY displayed on the control panel?**

NO

Reinstall the original FRU. Repeat the FRU replacement steps until the defective FRU is identified or all the FRUs have been exchanged.

If the symptom did not change and all the FRUs have been exchanged, call service support for assistance.

If the symptom has changed, check for loose cards, cables, and obvious problems.

If you do not find a problem, go to the [Start-of-call procedure](#) and follow the instructions for the new symptom.

YES

Go to [MAP 0410: Repair Checkout](#).

- PFW1548-505-7a

This step is reserved.

- PFW1548-505-8a

1. Turn off the power.
2. Reconnect the system console.
  - a. If an ASCII terminal has been defined as the firmware console, attach the ASCII terminal cable to the S1 connector on the rear of the system unit.
  - b. If a display attached to a display adapter has been defined as the firmware console, install the display adapter and connect the display to the adapter. Plug the keyboard and mouse into the keyboard connector on the rear of the system unit.
3. Turn on the power.
4. If the ASCII terminal or graphics display (including display adapter) is connected differently from the way it was previously, the console selection screen appears. Select a firmware console.
5. When the word keyboard is displayed, press the number 1 key on the directly attached keyboard, an ASCII terminal or HMC. This activates the system management services (SMS).
6. Enter the appropriate password if you are prompted to do so.

**Is the SMS screen displayed?**

NO

One of the FRUs remaining in the system unit is defective.

Exchange the FRUs that have not been exchanged, in the following order:

1. Replace the system backplane, location Un-P1.

2. If you are using a graphics display, go to the problem determination procedures for the display.

If you do not find a problem, do the following:

- Replace the display adapter.
- Replace the PCI riser in which the graphics adapter is plugged.
- Replace the backplane, location: Un-P1.

Repeat this step until the defective FRU is identified or all the FRUs have been exchanged.

If the symptom did not change and all the FRUs have been exchanged, call service support for assistance.

If the symptom changed, check for loose cards, cables, and obvious problems.

If you do not find a problem, go to the [Start-of-call procedure](#) and follow the instructions for the new symptom.

YES

Go to [PFW1548-505-9a](#).

- PFW1548-505-9a
  1. Make sure the diagnostic CD-ROM is inserted into the optical drive.
  2. Turn off the power and remove the power cords.
  3. Plug the IDE cable into the IDE connector on the system backplane.
  4. Connect the signal and power connectors to the IDE optical drive.
  5. Plug in the power cords and wait for "01" in the upper-left corner of the control panel display.
  6. Turn on the power.
  7. Insert the diagnostic CD-ROM into the optical drive.
  8. After the word keyboard is displayed, press the number 5 key on either the directly attached keyboard or an ASCII terminal keyboard.
  9. Enter the appropriate password if you are prompted to do so.

**Is the Please define the System Console screen displayed?**

NO

One of the FRUs remaining in the system unit is defective.

Exchange the FRUs that have not been exchanged, in the following order:

1. IDE cable
2. Optical drive
3. System backplane, location: Un-P1

Repeat this step until the defective FRU is identified or all the FRUs have been exchanged.

If the symptom did not change and all the FRUs have been exchanged, call service support for assistance.

If the symptom has changed, check for loose cards, cables, and obvious problems.

If you do not find a problem, go to the [Start-of-call procedure](#) and follow the instructions for the new symptom.

YES

Go to [PFW1548-505-12a](#).

- PFW1548-505-10a

This step is reserved.

- PFW1548-505-11a

This step is reserved.

- PFW1548-505-12a

The system is working correctly with this configuration. One of the disk drives that you removed from the disk drive backplanes may be defective.

1. Make sure the diagnostic CD-ROM is inserted into the optical drive.
2. Turn off the power and remove the power cords.
3. Install a disk drive in a disk drive backplane.
4. Plug in the power cords and wait for the "01" on the control panel display.

5. Turn on the power.
6. After the word keyboard is displayed, press the number 5 key on either the directly attached keyboard or an ASCII terminal keyboard.
7. Enter the appropriate password if you are prompted to do so.

**Is the Please define the System Console screen displayed?**

NO

Exchange the FRUs that have not been exchanged, in the following order:

1. Last disk drive installed
2. System backplane, location Un-P1 (since the disk drive backplane is not a separate FRU)

Repeat this step until the defective FRU is identified or all the FRUs have been exchanged. If the symptom did not change and all the FRUs have been exchanged, call service support for assistance.

If the symptom has changed, check for loose cards, cables, and obvious problems.

If you do not find a problem, go to the [Start-of-call procedure](#) and follow the instructions for the new symptom.

YES

Repeat this step with all disk drives that were installed in the disk drive backplane. Go to [PFW1548-505-14a](#).

- PFW1548-505-13a

This step is reserved.

- PFW1548-505-14a

The system is working correctly with this configuration. One of the devices that was disconnected from the system backplane may be defective.

1. Turn off the power and remove the power cords.
2. Attach a system backplane device (for example: parallel, system port 1, system port 2, system port 3, keyboard, mouse, Ethernet, Ultra-2 SCSI,) that had been removed.
3. Plug in the power cords and wait for "01" in the upper-left corner on the control panel display.
4. Turn on the power.
5. If the Console Selection screen is displayed, choose the system console.
6. After the word keyboard displays, press the number 5 key on either the directly attached keyboard or on an ASCII terminal keyboard.
7. Enter the appropriate password if you are prompted to do so.

**Is the Please define the System Console screen displayed?**

NO

The last device or cable that you attached is defective.

To test each FRU, exchange the FRUs in the following order:

1. Device and cable (last one attached)
2. System backplane, location: Un-P1.

If the symptom did not change and all the FRUs have been exchanged, call service support for assistance.

If the symptom has changed, check for loose cards, cables, and obvious problems.

If you do not find a problem, go to the [Start-of-call procedure](#) and follow the instructions for the new symptom. Go to [MAP 0410: Repair Checkout](#).

YES

Repeat this step until all of the devices are attached. Go to [PFW1548-505-15a](#).

- PFW1548-505-15a

The system is working correctly with this configuration. One of the PCI adapters that you removed may be defective.

1. Turn off the power and remove the power cords.
2. Install a FRU (adapter) and connect any cables and devices that were attached to the FRU.
3. Plug in the power cords and wait for the OK prompt to display on the control panel display.
4. Turn on the power.
5. If the Console Selection screen is displayed, choose the system console.

6. After the word keyboard displays, press the number 5 key on either the directly attached keyboard or on an ASCII terminal keyboard.
7. Enter the appropriate password if you are prompted to do so.

**Is the Please define the System Console screen displayed?**

NO

Go to [PFW1548-505-16a](#).

YES

Repeat this step until all of the FRUs (adapters) are installed. Go to [MAP 0410: Repair Checkout](#).

- PFW1548-505-16a

The last FRU installed or one of its attached devices is probably defective.

1. Make sure the diagnostic CD-ROM is inserted into the optical drive.
2. Turn off the power and remove the power cords.
3. Starting with the last installed adapter, disconnect one attached device and cable.
4. Plug in the power cords and wait for the "01" in the upper-left corner on the control panel display.
5. Turn on the power.
6. If the Console Selection screen is displayed, choose the system console.
7. After the word keyboard displays, press the number 5 key on either the directly attached keyboard or on an ASCII terminal keyboard.
8. Enter the appropriate password if you are prompted to do so.

**Is the Please define the System Console screen displayed?**

NO

Repeat this step until the defective device or cable is identified or all devices and cables have been disconnected.

If all the devices and cables have been removed, then one of the FRUs remaining in the system unit is defective.

To test each FRU, exchange the FRUs in the following order:

1. Adapter (last one installed)
2. PCI risers, location Un-P1-C12 and Un-P1-C13.
3. System backplane, location Un-P1

If the symptom did not change and all the FRUs have been exchanged, call service support for assistance.

If the symptom has changed, check for loose cards, cables, and obvious problems.

If you do not find a problem, go to the [Start-of-call procedure](#) and follow the instructions for the new symptom.

YES

The last device or cable that you disconnected is defective. Exchange the defective device or cable. Go to [MAP 0410: Repair Checkout](#).

- PFW1548-505-17a

1. Follow the instructions on the screen to select the system console.
2. When the DIAGNOSTIC OPERATING INSTRUCTIONS screen is displayed, press Enter.
3. Select Advanced Diagnostics Routines.
4. If the terminal type has not been defined, you must use the initialize terminal option on the FUNCTION SELECTION menu to initialize the AIX diagnostic environment before you can continue with the diagnostics. This is a separate operation from selecting the console display.
5. If the NEW RESOURCE screen is displayed, select an option from the bottom of the screen.

**Note:** Adapters and devices that require supplemental media are not shown in the new resource list. If the system has adapters or devices that require supplemental media, select option 1.

6. When the DIAGNOSTIC MODE SELECTION screen is displayed, press Enter.
7. Select All Resources. (If you were sent here from [PFW1548-505-21a](#), select the adapter or device that was loaded from the supplemental media).

Did you get an SRN?

NO

Go to [PFW1548-505-19a](#).

YES

Go to [PFW1548-505-18a](#).

- PFW1548-505-18a

Look at the FRU part numbers associated with the SRN.

**Have you exchanged all the FRUs that correspond to the failing function codes (FFCs)?**

NO

Exchange the FRU with the highest failure percentage that has not been changed.

Repeat this step until all the FRUs associated with the SRN have been exchanged or diagnostics run with no trouble found. Run diagnostics after each FRU is exchanged. Go to [MAP 0410: Repair Checkout](#).

YES

If the symptom did not change and all the FRUs have been exchanged, call service support for assistance.

- PFW1548-505-19a

**Does the system have adapters or devices that require supplemental media?**

NO

Go to [PFW1548-505-20a](#).

YES

Go to [PFW1548-505-21a](#).

- PFW1548-505-20a

Consult the PCI adapter configuration documentation for your operating system to verify that all adapters are configured correctly. Go to [MAP 0410: Repair Checkout](#).

If the symptom did not change and all the FRUs have been exchanged, call service support for assistance.

- PFW1548-505-21a

1. Select Task Selection.

2. Select Process Supplemental Media and follow the on screen instructions to process the media. Supplemental media must be loaded and processed one at a time.

**Did the system return to the TASKS SELECTION SCREEN after the supplemental media was processed?**

NO

Go to [PFW1548-505-22a](#).

YES

Press F3 to return to the FUNCTION SELECTION screen. Go to [step 4](#).

- PFW1548-505-22a

The adapter or device is probably defective.

If the supplemental media is for an adapter, replace the FRUs in the following order:

1. Adapter
2. PCI riser cards, location Un-P1-C12 and UN-P1-C13.
3. System backplane, location Un-P1

If the supplemental media is for a device, replace the FRUs in the following order:

1. Device and any associated cables
2. The adapter to which the device is attached

Repeat this step until the defective FRU is identified or all the FRUs have been exchanged.

If the symptom did not change and all the FRUs have been exchanged, call service support for assistance.

If the symptom has changed, check for loose cards, cables, and obvious problems.



If you do not find a problem, go to the [Start-of-call procedure](#) and follow the instructions for the new symptom. Go to [MAP 0410: Repair Checkout](#).

End of procedure.

---

## PFW1548-510: Processor subsystem problem isolation procedure for model ESCALA PL 250R-L, ESCALA PL 250R-L+ or ESCALA PL 450R-VL+, with an HMC attached

Use this problem isolation procedure to aid in solving memory and processor problems on ESCALA PL 250R-L attached to an HMC.

- PFW1548-510-1

1. Insure that the diagnostics and the operating system are shut down.

**Is the system at "service processor standby", indicated by "01" in the control panel?**

NO

Replace the system backplane, location: Un-P1. Return to the beginning of this step.

YES

Continue with substep 2.

2. Turn on the power using either the white button or the HMC.

**Does the managed system reach "service processor standby" indicated by "01" in the control panel?**

NO

Go to step [PFW1548-510-3](#).

YES

Go to step [PFW1548-510-2](#).

- PFW1548-510-2

1. Insert the diagnostic CD-ROM into the optical drive.

**Note:** If you cannot insert the diagnostic CD-ROM, go to [PFW1548-510-3](#).

2. Turn on the power using either the HMC or the white button. (If the diagnostic CD-ROM is not in the optical drive, insert it now.) After the system has reached hypervisor standby, activate a Linux or AIX partition by clicking on the "Advanced" button on the activation screen. On the "advanced" activation screen, select "boot in service mode using the default boot list" to boot the diagnostic CD-ROM.

3. If you are prompted to do so, enter the appropriate password.

**Is the "Please define the System Console" screen displayed?**

NO

Go to step [PFW1548-510-3](#).

YES

Go to step [PFW1548-510-21](#).

- PFW1548-510-3

1. Turn off the power.
2. If you have not already done so, configure the service processor (using the ASMI menus) with the instructions in note 6 at the beginning of this procedure, then return here and continue.
3. Exit the service processor (ASMI) menus and remove the power cords.
4. Disconnect all external cables (parallel, system port 1, system port 2, keyboard, mouse, Ethernet on the system planar, Ethernet on the service processor if present, and so on). Leave the Ethernet cable between the service processor and the HMC attached.
5. Remove the service access cover (model xxx), or place the drawer (model yyy), into the service position and remove the service access cover.
6. Record the slot numbers of the PCI adapters. Label and record the locations of all cables attached to the adapters. Disconnect all cables attached to the adapters and remove all of the adapters.
7. Disconnect all of the power and signal cables from the media drives located in media bay.

8. Remove the media drives.
9. Record the slot numbers of the memory DIMMs on the system backplane. Remove all memory DIMMs except for one pair from the system backplane.

**Notes:**

- a. Place the memory DIMM locking tabs in the locked (upright) position to prevent damage to the tabs.
  - b. Memory DIMMs must be installed in pairs and in the correct connectors. Refer to the memory DIMM section of [Locations-Model ESCALA PL 250R-L](#) for information on memory DIMMs.
10. Disconnect the IDE cable from the IDE connector on the system backplane.
  11. Disconnect the signal and power connectors from both disk drive backplanes.
  12. Disconnect the disk drives (if present) from the disk drive backplane.
  13. Plug in the power cords and wait for "01" in the upper-left corner of the control panel display.
  14. Turn on the power using either the HMC or the white button. (If the diagnostic CD-ROM is not in the optical drive, insert it now.) After the system has reached hypervisor standby, activate a Linux or AIX partition by clicking on the "Advanced" button on the activation screen. On the "advanced" activation screen, select "boot in service mode using the default boot list" to boot the diagnostic CD-ROM.

**Does the system stop with B1xxF22A, CA00E1F2, CA00E1F3, or STBY displayed on the control panel?**

NO

Go to [PFW1548-510-7](#).

YES

Go to [PFW1548-510-4](#).

- PFW1548-510-4

**Were any memory DIMMs removed from the system backplane?**

NO

Go to [PFW1548-510-9](#).

YES

Go to [PFW1548-510-5](#).

- PFW1548-510-5
  1. Turn off the power, and remove the power cords.
  2. Replug the memory DIMMs that were removed from the system backplane in [PFW1548-510-2](#) in their original locations.

**Notes:**

- a. Place the memory DIMM locking tabs into the locked (upright) position to prevent damage to the tabs.
  - b. Memory DIMMs must be installed in pairs in the correct connectors. Refer to [Memory DIMM locations](#) for information on memory DIMMs.
3. Plug in the power cords and wait for "01" in the control panel display.
  4. Turn on the power using either the HMC or the white button. (If the diagnostic CD-ROM is not in the optical drive, insert it now.) After the system has reached hypervisor standby, activate a Linux or AIX partition by clicking on the "Advanced" button on the activation screen. On the "advanced" activation screen, select "boot in service mode using the default boot list" to boot the diagnostic CD-ROM.
  5. If you are prompted to do so, enter the appropriate password.

**Does the system stop with B1xxF22A, CA00E1F2, CA00E1F3, or STBY displayed on the control panel?**

NO

A memory DIMM in the pair you just replaced in the system is defective. Turn off the power, remove the power cords, and exchange the memory DIMMs in that pair one at a time with new or previously removed memory DIMMs. Repeat this step until the defective memory DIMM is identified, or all memory DIMMs have been exchanged.

If your symptom did not change and all the memory DIMMs have been exchanged, call your service support person for assistance.

If the symptom changed, check for loose cards and obvious problems.

If you do not find a problem, go to the [Start-of-call procedure](#) and follow the instructions for the new symptom.

YES

Go to [PFW1548-510-9](#).

- PFW1548-510-6

This step is reserved.

- PFW1548-510-7

One of the FRUs remaining in the system unit is defective.

**Note:** If a memory DIMM is exchanged, insure that the new memory DIMM is the same size and speed as the original memory DIMM.

1. Turn off the power, remove the power cords, and exchange the following FRUs in the order listed:
  - a. Memory DIMMs. Exchange one at a time with new or previously removed DIMMs
  - b. System backplane, location UN-P1
  - c. Power supplies.
2. Plug in the power cords and wait for "01" in the upper-left corner of the control panel display.
3. Turn on the power using either the HMC or the white button. (If the diagnostic CD-ROM is not in the optical drive, insert it now.) After the system has reached hypervisor standby, activate a Linux or AIX partition by clicking on the "Advanced" button on the activation screen. On the "advanced" activation screen, select "boot in service mode using the default boot list" to boot the diagnostic CD-ROM.

**Does the system stop with B1xxF22A, CA00E1F2, CA00E1F3, or STBY displayed on the control panel?**

NO

Reinstall the original FRU. Repeat the FRU replacement steps until the defective FRU is identified or all the FRUs have been exchanged.

If the symptom did not change and all the FRUs have been exchanged, call service support for assistance.

If the symptom has changed, check for loose cards, cables, and obvious problems.

If you do not find a problem, go to the [Start-of-call procedure](#) and follow the instructions for the new symptom.

YES

Go to [MAP 0410: Repair Checkout](#).

- PFW1548-510-8

This step is reserved.

- PFW1548-510-9
  1. Turn off the power.
  2. Reconnect the system console.

**Notes:**

- a. If an ASCII terminal has been defined as the firmware console, attach the ASCII terminal cable to the S1 connector on the rear of the system unit.
- b. If a display attached to a display adapter has been defined as the firmware console, install the display adapter and connect the display to the adapter. Plug the keyboard and mouse into the keyboard connector on the rear of the system unit.

3. Turn on the power using either the HMC or the white button. (If the diagnostic CD-ROM is not in the optical drive, insert it now.) After the system has reached hypervisor standby, activate a Linux or AIX partition by clicking on the "Advanced" button on the activation screen. On the "advanced" activation screen, select "boot in service mode using the default boot list" to boot the diagnostic CD-ROM.
4. If the ASCII terminal or graphics display (including display adapter) is connected differently from the way it was previously, the console selection screen appears. Select a firmware console.
5. When the word keyboard is displayed, press the number 1 key on the directly attached keyboard, an ASCII terminal or HMC. This activates the system management services (SMS).
6. Enter the appropriate password if you are prompted to do so.

**Is the SMS screen displayed?**

NO

One of the FRUs remaining in the system unit is defective.

Exchange the FRUs that have not been exchanged, in the following order:

1. Replace the service processor, location Un-P1.
2. If you are using a graphics display, go to the problem determination procedures for the display.

If you do not find a problem, do the following:

- Replace the display adapter.
- Replace the backplane in which the graphics adapter is plugged.

Repeat this step until the defective FRU is identified or all the FRUs have been exchanged.

If the symptom did not change and all the FRUs have been exchanged, call service support for assistance.

If the symptom changed, check for loose cards, cables, and obvious problems.

If you do not find a problem, go to the [Start-of-call procedure](#) and follow the instructions for the new symptom.

YES

Go to [PFW1548-510-10](#).

## • PFW1548-510-10

1. Make sure the diagnostic CD-ROM is inserted into the optical drive.
2. Turn off the power and remove the power cords.
3. Plug the IDE cable into the IDE connector on the system backplane.
4. Connect the signal and power connectors to the IDE optical drive.
5. Plug in the power cords and wait for "01" in the upper-left corner of the control panel display.
6. Turn on the power using either the HMC or the white button. (If the diagnostic CD-ROM is not in the optical drive, insert it now.) After the system has reached hypervisor standby, activate a Linux or AIX partition by clicking on the "Advanced" button on the activation screen. On the "advanced" activation screen, select "boot in service mode using the default boot list" to boot the diagnostic CD-ROM.
7. After the word keyboard is displayed, press the number 5 key on either the directly attached keyboard or an ASCII terminal keyboard.
8. Enter the appropriate password if you are prompted to do so.

**Is the Please define the System Console screen displayed?**

NO

One of the FRUs remaining in the system unit is defective.

Exchange the FRUs that have not been exchanged, in the following order:

1. IDE cable
2. Optical drive
3. System backplane, location Un-P1

Repeat this step until the defective FRU is identified or all the FRUs have been exchanged.

If the symptom did not change and all the FRUs have been exchanged, call service support for assistance.

If the symptom has changed, check for loose cards, cables, and obvious problems.

If you do not find a problem, go to the [Start-of-call procedure](#) and follow the instructions for the new symptom.

YES

Go to [PFW1548-510-11](#).

- PFW1548-510-11

The system is working correctly with this configuration. One of the SCSI devices that was disconnected may be defective.

1. Make sure the diagnostic CD-ROM is inserted into the optical drive.
2. Turn off the power and remove the power cords.
3. Install a disk drive in a disk drive backplane.
4. Plug the power cords and wait for "01" on the control panel display.
5. Turn on the power using either the HMC or the white button. (If the diagnostic CD-ROM is not in the optical drive, insert it now.) After the system has reached hypervisor standby, activate a Linux or AIX partition by clicking on the "Advanced" button on the activation screen. On the "advanced" activation screen, select "boot in service mode using the default boot list" to boot the diagnostic CD-ROM.
6. After the word keyboard is displayed, press the number 5 key on either the directly attached keyboard or on an ASCII terminal keyboard.
7. Enter the appropriate password if you are prompted to do so.

**Is the Please define the System Console screen displayed?**

NO

Exchange the FRUs that have not been exchanged, in the following order:

1. Last disk drive installed
2. System backplane, location Un-P1 (Since the disk drive backplane is not a separate FRU)

Repeat this step until the defective FRU is identified or all the FRUs have been exchanged.

If the symptom did not change and all the FRUs have been exchanged, call service support for assistance.

If the symptom has changed, check for loose cards, cables, and obvious problems.

If you do not find a problem, go to the [Start-of-call procedure](#) and follow the instructions for the new symptom.

YES

Repeat this step with all disk drives that were installed in the disk drive backplane. Go to [PFW1548-510-12](#).

- PFW1548-510-12

This step is reserved.

- PFW1548-510-13

The system is working correctly with this configuration. One of the disk drive backplanes may be defective.

1. Turn off the power and remove the power cords.
2. Attach a system backplane device (for example: parallel, system port 1, system port 2, Ethernet, SCSI, keyboard or mouse) that had been removed.
3. Plug in the power cords and wait for "01" in the upper-left corner on the control panel display.
4. Turn on the power using either the HMC or the white button. (If the diagnostic CD-ROM is not in the optical drive, insert it now.) After the system has reached hypervisor standby, activate a Linux or AIX partition by clicking on the "Advanced" button on the activation screen. On the "advanced" activation screen, select "boot in service mode using the default boot list" to boot the diagnostic CD-ROM.
5. If the Console Selection screen is displayed, choose the system console.
6. After the word keyboard is displayed, press the number 5 key on either the directly attached keyboard or an ASCII terminal keyboard.
7. Enter the appropriate password if you are prompted to do so.

**Is the Please define the System Console screen displayed?**

NO

The last device or cable that you attached is defective. To test each FRU, exchange the FRUs in the following order:

1. Device and cable (last one attached)
2. System backplane

If the symptom did not change and all the FRUs have been exchanged, call service support for assistance.

If the symptom has changed, check for loose cards, cables, and obvious problems.

If you do not find a problem, go to the [Start-of-call procedure](#) and follow the instructions for the new symptom. Go to [MAP 0410: Repair Checkout](#).

YES

Repeat this step until all of the devices are attached. Go to step [PFW1548-510-14](#).

• PFW1548-510-14

The system is working correctly with this configuration. One of the disk drives that you removed from the disk drive backplanes may be defective.

1. Turn off the power and remove the power cords.
2. Install a FRU (adapter) and connect any cables and devices that were attached to the FRU.
3. Plug in the power cords and wait for the OK prompt to display on the control panel display.
4. Turn on the power using either the HMC or the white button. (If the diagnostic CD-ROM is not in the optical drive, insert it now.) After the system has reached hypervisor standby, activate a Linux or AIX partition by clicking on the "Advanced" button on the activation screen. On the "advanced" activation screen, select "boot in service mode using the default boot list" to boot the diagnostic CD-ROM.
5. If the Console Selection screen is displayed, choose the system console.
6. After the word keyboard displays, press the number 5 key on either the directly attached keyboard, virtual terminal on the HMC, or an ASCII terminal.
7. Enter the appropriate password if you are prompted to do so.

**Is the Please define the System Console screen displayed?**

NO

Go to step [PFW1548-510-15](#).

YES

Repeat this step until all of the FRUs (adapters) are installed. Go to [MAP 0410: Repair Checkout](#).

• PFW1548-510-15

The last FRU installed or one of its attached devices is probably defective.

1. Make sure the diagnostic CD-ROM is inserted into the optical drive.
2. Turn off the power and remove the power cords.
3. Starting with the last installed adapter, disconnect one attached device and cable.
4. Plug in the power cords and wait for "01" in the upper-left corner of the control panel display.
5. Turn on the power using either the HMC or the white button. (If the diagnostic CD-ROM is not in the optical drive, insert it now.) After the system has reached hypervisor standby, activate a Linux or AIX partition by clicking on the "Advanced" button on the activation screen. On the "advanced" activation screen, select "boot in service mode using the default boot list" to boot the diagnostic CD-ROM.
6. If the Console Selection screen is displayed, choose the system console.
7. After the word keyboard displays, press the number 5 key on either the directly attached keyboard, virtual terminal on the HMC, or an ASCII terminal.
8. Enter the appropriate password if you are prompted to do so.

**Is the Please define the System Console screen displayed?**

NO

Repeat this step until the defective device or cable is identified or all devices and cables have been disconnected.

If all the devices and cables have been removed, then one of the FRUs remaining in the system unit is defective.

To test each FRU, exchange the FRUs in the following order:

1. Adapter (the last one installed)
2. PCI backplane, Un-P2

### 3. System backplane, Un-P1

If the symptom did not change and all the FRUs have been exchanged, call service support for assistance.

If the symptom has changed, check for loose cards, cables, and obvious problems.

If you do not find a problem return, go to the [Start-of-call procedure](#) and follow the instructions for the new symptom.

YES

The last device or cable that you disconnected is defective. Exchange the defective device or cable. Go to [MAP 0410: Repair Checkout](#).

- PFW1548-510-16

The system is working correctly with this configuration. One of the devices that was disconnected from the system backplane may be defective.

1. Follow the instructions on the screen to select the system console.
2. When the DIAGNOSTIC OPERATING INSTRUCTIONS screen is displayed, press Enter.
3. Select Advanced Diagnostics Routines.
4. If the terminal type has not been defined, you must use the initialize terminal option on the FUNCTION SELECTION menu to initialize the AIX diagnostic environment before you can continue with the diagnostics. This is a separate operation from selecting the console display.
5. If the NEW RESOURCE screen is displayed, select an option from the bottom of the screen.

**Note:** Adapters and devices that require supplemental media are not shown in the new resource list. If the system has adapters or devices that require supplemental media, select option 1.

6. When the DIAGNOSTIC MODE SELECTION screen is displayed, press Enter.
7. Select All Resources. (If you were sent here from step PFW1548-510-20, select the adapter or device that was loaded from the supplemental media).

#### **Did you get an SRN?**

NO

Go to step [PFW1548-510-18](#).

YES

Go to [PFW1548-510-17](#).

- PFW1548-510-17

Look at the FRU part numbers associated with the SRN

#### **Have you exchanged all the FRUs that correspond to the failing function codes (FFCs)?**

NO

Exchange the FRU with the highest failure percentage that has not been changed.

Repeat this step until all the FRUs associated with the SRN have been exchanged or diagnostics run with no trouble found. Run diagnostics after each FRU is exchanged. Go to [MAP 0410: Repair Checkout](#).

YES

If the symptom did not change and all the FRUs have been exchanged, call service support for assistance.

- PFW1548-510-18

#### **Does the system have adapters or devices that require supplemental media?**

NO

Go to step [PFW1548-510-19](#).

YES

Go to step [PFW1548-510-20](#).

- PFW1548-510-19

Consult the PCI adapter configuration documentation for your operating system to verify that all adapters are configured correctly. Go to [MAP 0410: Repair Checkout](#).

If the symptom did not change and all the FRUs have been exchanged, call service support for assistance.

- PFW1548-510-20
  1. Select Task Selection.
  2. Select Process Supplemental Media and follow the on screen instructions to process the media. Supplemental media must be loaded and processed one at a time.

**Did the system return to the TASKS SELECTION SCREEN after the supplemental media was processed?**

NO

Go to [PFW1548-510-21](#).

YES

Press F3 to return to the FUNCTION SELECTION screen. Go to [4](#).

- PFW1548-510-21

The adapter or device is probably defective.

If the supplemental media is for an adapter, replace the FRUs in the following order:

1. Adapter
2. PCI backplane, Un-P2.
3. System backplane, Un-P1.

If the supplemental media is for a device, replace the FRUs in the following order:

1. Device and any associated cables
2. The adapter to which the device is attached

Repeat this step until the defective FRU is identified or all the FRUs have been exchanged.

If the symptom did not change and all the FRUs have been exchanged, call service support for assistance.

If the symptom has changed, check for loose cards, cables, and obvious problems.

If you do not find a problem, go to the [Start-of-call procedure](#) and follow the instructions for the new symptom. Go to [MAP 0410: Repair Checkout](#).

End of procedure.

## **PFW1548-510: Processor subsystem problem isolation procedure for model ESCALA PL 250R-L, ESCALA PL 250R-L+ or ESCALA PL 450R-VL+, without an HMC attached**

Use this problem isolation procedure to aid in solving memory and processor problems on ESCALA PL 250R-L that is not attached to an HMC.

- PFW1548-510-1a
  1. Insure that the diagnostics and the operating system(s) are shut down.
  2. Turn on the power.
  3. Insert the AIX diagnostic CD-ROM into the optical drive.

**Note:** If you cannot insert the diagnostic CD-ROM, go to [PFW1548-510-2a](#).

4. When the keyboard indicator is displayed on the system console:
  - ◇ On an ASCII terminal or directly-attached keyboard, press the number 5 key.
5. If you are prompted to do so, enter the appropriate password.

**Is the "Please define the System Console" screen displayed?**

NO

Go to step [PFW1548-510-2a](#).

YES



Go to step [PFW1548-510-17a](#).

- PFW1548-510-2a
  1. Turn on the power.
  2. If you have not already done so, configure the service processor (using the ASMI menus) with the instructions in note 6 at the beginning of this MAP, then return here and continue.
  3. Exit the service processor (ASMI) menus and remove the power cords.
  4. Disconnect all external cables (parallel, system port 1, system port 2, keyboard, mouse, Ethernet on the system planar, Ethernet on the service processor if present, and so on).
  5. Remove the service access cover (model xxx), or place the drawer (model yyy), into the service position and remove the service access cover.
  6. Record the slot numbers of the PCI adapters. Label and record the locations of all cables attached to the adapters. Disconnect all cables attached to the adapters and remove all of the adapters.
  7. Disconnect all of the power and signal cables from the media drives located in the media bay.
  8. Remove the media drives.
  9. Record the slot numbers of the memory DIMMs on the system backplane. Remove all memory DIMMs except for one pair from the system backplane.

**Notes:**

- a. Place the memory DIMM locking tabs in the locked (upright) position to prevent damage to the tabs.
- b. Memory DIMMs must be installed in pairs and in the correct connectors. Refer to "Memory DIMM Locations" for information on memory DIMMs.

10. Disconnect the IDE cable from the IDE connector on the system backplane.
11. Disconnect the signal and power connectors from both disk drive backplanes.
12. Disconnect the disk drives (if present) from both disk drive backplanes.
13. Plug in the power cords and wait for "01" in the upper-left-hand corner of the control panel display.
14. Turn on the power.

**Does the system stop with B1xxF22A, CA00E1F2, CA00E1F3, or STBY displayed on the control panel?**

NO

Go to step [PFW1548-510-6a](#).

YES

Go to step [PFW1548-510-3a](#).

- PFW1548-510-3a

**Were any memory DIMMs removed from the system backplane?**

NO

Go to step [PFW1548-510-8a](#).

YES

Go to step [PFW1548-510-4a](#).

- PFW1548-510-4a
  1. Turn off the power, and remove the power cords.
  2. Replug the memory DIMMs that were removed from the system backplane in step PFW1548-510-2a in their original locations.

**Notes:**

- a. Place the memory DIMM locking tabs into the locked (upright) position to prevent damage to the tabs.
- b. Memory DIMMs must be installed in pairs in the correct connectors. Refer to "Memory DIMM Locations" for information on memory DIMMs.

3. Plug in the power cords and wait for "01" in the control panel display.
4. Turn on the power.

**Does the system stop with B1xxF22A, CA00E1F2, CA00E1F3, or STBY displayed on the control panel?**

NO

A memory DIMM in the pair you just replaced in the system is defective. Turn off the power, remove the power cords, and exchange the memory DIMMs in that pair one at a time with new or previously removed memory DIMMs. Repeat this step until the defective memory DIMM is identified, or all memory DIMMs have been exchanged.

If your symptom did not change and all the memory DIMMs have been exchanged, call your service support person for assistance.

If the symptom changed, check for loose cards and obvious problems.

If you do not find a problem, go to the [Start-of-Call MAP](#) and follow the instructions for the new symptom.

YES

Go to [PFW1548-510-8a](#).

- PFW1548-510-5a

This step is reserved.

- PFW1548-510-6a

One of the FRUs remaining in the system unit is defective.

**Note:** If a memory DIMM is exchanged, insure that the new memory DIMM is the same size and speed as the original memory DIMM.

1. Turn off the power, remove the power cords, and exchange the following FRUs in the order listed:
  - a. Memory DIMMs. Exchange one at a time with new or previously removed DIMMs
  - b. System backplane, location Un-P1.
  - c. Power supplies.
2. Plug in the power cords and wait for "01" in the upper-left corner of the control panel display.
3. Turn on the power.

**Does the system stop with B1xxF22A, CA00E1F2, CA00E1F3, or STBY displayed on the control panel?**

NO

Reinstall the original FRU. Repeat the FRU replacement steps until the defective FRU is identified or all the FRUs have been exchanged.

If the symptom did not change and all the FRUs have been exchanged, call service support for assistance.

If the symptom has changed, check for loose cards, cables, and obvious problems.

If you do not find a problem, go to the [Start-of-call procedure](#) and follow the instructions for the new symptom.

YES

Go to [MAP 0410: Repair Checkout](#).

- PFW1548-510-7a

This step is reserved.

- PFW1548-510-8a
  1. Turn off the power.
  2. Reconnect the system console.
    - a. If an ASCII terminal has been defined as the firmware console, attach the ASCII terminal cable to the S1 connector on the rear of the system unit.
    - b. If a display attached to a display adapter has been defined as the firmware console, install the display adapter and connect the display to the adapter. Plug the keyboard and mouse into the keyboard connector on the rear of the system unit.
  3. Turn on the power.
  4. If the ASCII terminal or graphics display (including display adapter) is connected differently from the way it was previously, the console selection screen appears. Select a firmware console.

5. When the word keyboard is displayed, press the number 1 key on the directly attached keyboard, an ASCII terminal or HMC. This activates the system management services (SMS).
6. Enter the appropriate password if you are prompted to do so.

**Is the SMS screen displayed?**

NO

One of the FRUs remaining in the system unit is defective.

Exchange the FRUs that have not been exchanged, in the following order:

1. Replace the system backplane, location Un-P1.
2. If you are using a graphics display, go to the problem determination procedures for the display.

If you do not find a problem, do the following:

- Replace the display adapter.
- Replace the backplane in which the graphics adapter is plugged.

Repeat this step until the defective FRU is identified or all the FRUs have been exchanged.

If the symptom did not change and all the FRUs have been exchanged, call service support for assistance.

If the symptom changed, check for loose cards, cables, and obvious problems.

If you do not find a problem, go to the [Start-of-call procedure](#) and follow the instructions for the new symptom.

YES

Go to [PFW1548-510-9a](#).

- PFW1548-510-9a
  1. Make sure the diagnostic CD-ROM is inserted into the optical drive.
  2. Turn off the power and remove the power cords.
  3. Plug the IDE cable into the IDE connector on the system backplane.
  4. Connect the signal and power connectors to the IDE optical drive.
  5. Plug in the power cords and wait for "01" in the upper-left corner of the control panel display.
  6. Turn on the power.
  7. Insert the diagnostic CD-ROM into the optical drive.
  8. After the word keyboard is displayed, press the number 5 key on either the directly attached keyboard or an ASCII terminal keyboard.
  9. Enter the appropriate password if you are prompted to do so.

**Is the Please define the System Console screen displayed?**

NO

One of the FRUs remaining in the system unit is defective.

Exchange the FRUs that have not been exchanged, in the following order:

1. IDE cable
2. Optical drive
3. System backplane

Repeat this step until the defective FRU is identified or all the FRUs have been exchanged.

If the symptom did not change and all the FRUs have been exchanged, call service support for assistance.

If the symptom has changed, check for loose cards, cables, and obvious problems.

If you do not find a problem, go to the [Start-of-call procedure](#) and follow the instructions for the new symptom.

YES

Go to [PFW1548-510-12a](#).

- PFW1548-510-10a

This step is reserved.

- PFW1548-510-11a

This step is reserved.

- PFW1548-510-12a

The system is working correctly with this configuration. One of the disk drives that you removed from the disk drive backplanes may be defective.

1. Make sure the diagnostic CD-ROM is inserted into the optical drive.
2. Turn off the power and remove the power cords.
3. Install a disk drive in a disk drive backplane.
4. Plug in the power cords and wait for the "01" on the control panel display.
5. Turn on the power.
6. After the word keyboard is displayed, press the number 5 key on either the directly attached keyboard or an ASCII terminal keyboard.
7. Enter the appropriate password if you are prompted to do so.

**Is the Please define the System Console screen displayed?**

NO

Exchange the FRUs that have not been exchanged, in the following order:

1. Last disk drive installed
2. System backplane, location Un-P1 (since the disk drive backplane is not a separate FRU)

Repeat this step until the defective FRU is identified or all the FRUs have been exchanged. If the symptom did not change and all the FRUs have been exchanged, call service support for assistance.

If the symptom has changed, check for loose cards, cables, and obvious problems.

If you do not find a problem, go to the [Start-of-call procedure](#) and follow the instructions for the new symptom.

YES

Repeat this step with all disk drives that were installed in the disk drive backplane. Go to [PFW1548-510-14a](#).

- PFW1548-510-13a

This step is reserved.

- PFW1548-510-14a

The system is working correctly with this configuration. One of the devices that was disconnected from the system backplane may be defective.

1. Turn off the power and remove the power cords.
2. Attach a system backplane device (for example: parallel, system port 1, system port 2, system port 3, keyboard, mouse, Ethernet, Ultra-2 SCSI,) that had been removed.
3. Plug in the power cords and wait for "01" in the upper-left corner on the control panel display.
4. Turn on the power.
5. If the Console Selection screen is displayed, choose the system console.
6. After the word keyboard displays, press the number 5 key on either the directly attached keyboard or on an ASCII terminal keyboard.
7. Enter the appropriate password if you are prompted to do so.

**Is the Please define the System Console screen displayed?**

NO

The last device or cable that you attached is defective.

To test each FRU, exchange the FRUs in the following order:

1. Device and cable (last one attached)
2. System backplane

If the symptom did not change and all the FRUs have been exchanged, call service support for assistance.

If the symptom has changed, check for loose cards, cables, and obvious problems.

If you do not find a problem, go to the [Start-of-call procedure](#) and follow the instructions for the new symptom. Go to [MAP 0410: Repair Checkout](#).

YES

Repeat this step until all of the devices are attached. Go to [PFW1548-510-15a](#).

- PFW1548-510-15a

The system is working correctly with this configuration. One of the FRUs (adapters) that you removed may be defective.

1. Turn off the power and remove the power cords.
2. Install a FRU (adapter) and connect any cables and devices that were attached to the FRU.
3. Plug in the power cords and wait for the OK prompt to display on the control panel display.
4. Turn on the power.
5. If the Console Selection screen is displayed, choose the system console.
6. After the word keyboard displays, press the number 5 key on either the directly attached keyboard or on an ASCII terminal keyboard.
7. Enter the appropriate password if you are prompted to do so.

**Is the Please define the System Console screen displayed?**

NO

Go to [PFW1548-510-16a](#).

YES

Repeat this step until all of the FRUs (adapters) are installed. Go to [MAP 0410: Repair Checkout](#).

- PFW1548-510-16a

The last FRU installed or one of its attached devices is probably defective.

1. Make sure the diagnostic CD-ROM is inserted into the optical drive.
2. Turn off the power and remove the power cords.
3. Starting with the last installed adapter, disconnect one attached device and cable.
4. Plug in the power cords and wait for the "01" in the upper-left corner on the control panel display.
5. Turn on the power.
6. If the Console Selection screen is displayed, choose the system console.
7. After the word keyboard displays, press the number 5 key on either the directly attached keyboard or on an ASCII terminal keyboard.
8. Enter the appropriate password if you are prompted to do so.

**Is the Please define the System Console screen displayed?**

NO

Repeat this step until the defective device or cable is identified or all devices and cables have been disconnected.

If all the devices and cables have been removed, then one of the FRUs remaining in the system unit is defective.

To test each FRU, exchange the FRUs in the following order:

1. Adapter (last one installed)
2. PCI backplane, location Un-P2.
3. System backplane, location Un-P1

If the symptom did not change and all the FRUs have been exchanged, call service support for assistance.

If the symptom has changed, check for loose cards, cables, and obvious problems.

If you do not find a problem, go to the [Start-of-call procedure](#) and follow the instructions for the new symptom.

YES

The last device or cable that you disconnected is defective. Exchange the defective device or cable. Go to [MAP 0410: Repair Checkout](#).

- PFW1548-510-17a

1. Follow the instructions on the screen to select the system console.
2. When the DIAGNOSTIC OPERATING INSTRUCTIONS screen is displayed, press Enter.
3. Select Advanced Diagnostics Routines.
4. If the terminal type has not been defined, you must use the initialize terminal option on the FUNCTION SELECTION menu to initialize the AIX diagnostic environment before you can continue with the diagnostics. This is a separate operation from selecting the console display.
5. If the NEW RESOURCE screen is displayed, select an option from the bottom of the screen.

**Note:** Adapters and devices that require supplemental media are not shown in the new resource list. If the system has adapters or devices that require supplemental media, select option 1.

6. When the DIAGNOSTIC MODE SELECTION screen is displayed, press Enter.
7. Select All Resources. (If you were sent here from [PFW1548-510-21a](#), select the adapter or device that was loaded from the supplemental media).

Did you get an SRN?

NO

Go to [PFW1548-510-19a](#).

YES

Go to [PFW1548-510-18a](#).

- PFW1548-510-18a

Look at the FRU part numbers associated with the SRN.

#### **Have you exchanged all the FRUs that correspond to the failing function codes (FFCs)?**

NO

Exchange the FRU with the highest failure percentage that has not been changed.

Repeat this step until all the FRUs associated with the SRN have been exchanged or diagnostics run with no trouble found. Run diagnostics after each FRU is exchanged. Go to [MAP 0410: Repair Checkout](#).

YES

If the symptom did not change and all the FRUs have been exchanged, call service support for assistance.

- PFW1548-510-19a

#### **Does the system have adapters or devices that require supplemental media?**

NO

Go to [PFW1548-510-20a](#).

YES

Go to [PFW1548-510-21a](#).

- PFW1548-510-20a

Consult the PCI adapter configuration documentation for your operating system to verify that all adapters are configured correctly. Go to [MAP 0410: Repair Checkout](#).

If the symptom did not change and all the FRUs have been exchanged, call service support for assistance.

- PFW1548-510-21a

1. Select Task Selection.

2. Select Process Supplemental Media and follow the on screen instructions to process the media. Supplemental media must be loaded and processed one at a time.

#### **Did the system return to the TASKS SELECTION SCREEN after the supplemental media was processed?**

NO

Go to [PFW1548-510-22a](#).

YES

Press F3 to return to the FUNCTION SELECTION screen. Go to [step 4](#).

- PFW1548-510-22a

The adapter or device is probably defective.

If the supplemental media is for an adapter, replace the FRUs in the following order:

1. Adapter
2. PCI backplane, location Un-P2.
3. System backplane, location Un-P1

If the supplemental media is for a device, replace the FRUs in the following order:

1. Device and any associated cables
2. The adapter to which the device is attached

Repeat this step until the defective FRU is identified or all the FRUs have been exchanged.

If the symptom did not change and all the FRUs have been exchanged, call service support for assistance.

If the symptom has changed, check for loose cards, cables, and obvious problems.

If you do not find a problem, go to the [Start-of-call procedure](#) and follow the instructions for the new symptom. Go to [MAP 0410: Repair Checkout](#).

End of procedure.

## **PFW1542-520: I/O problem isolation procedure for model ESCALA PL 250T/R, ESCALA PL 250T/R+ or ESCALA PL 450T/R-L+,**

Use this procedure to locate defective FRUs not found by normal diagnostics when servicing an ESCALA PL 250T/R.

For this procedure, diagnostics are run on a minimally configured system. If a failure is detected on the minimally configured system, the remaining FRUs are exchanged one at a time until the failing FRU is identified. If a failure is not detected, FRUs are added back until the failure occurs. The failure is then isolated to the failing FRU.

- PFW1542-520-1
  1. Insure that the diagnostics and the operating system are shut down.
  2. Turn off the power.
  3. Select "Slow System Boot Speed" on the Power On/Off system menu under the Power/Restart Control menu on the ASMI.
  4. Turn on the power.
  5. Put the AIX diagnostic CD-ROM into the optical drive.

**Does the optical drive appear to operate correctly?**

NO

Go to [Problems with loading and starting the operating system](#).

YES

Continue to [PFW1542-520-2](#).

- PFW1542-520-2
  1. When the keyboard indicator is displayed (the word keyboard), if the system or partition gets that far in the IPL process, press the 5 key on the firmware console.
  2. Enter the appropriate password if you are prompted to do so.

**Is the Please define the System Console screen displayed?**

NO

Continue to [PFW1542-520-3](#).

YES

Go to [PFW1542-520-4](#).

- PFW1542-520-3

The system is unable to boot standalone AIX diagnostics. Check the service processor error log (using the ASMI) and the operator panel for additional error codes resulting from the slow boot that was performed in PFW1542-520-1.

**Did the slow boot generate a different error code or partition firmware hang from the one that originally sent you to PFW1542?**

NO

If you were sent here by an error code, and the error code did not change as the result of a slow boot, you have a processor subsystem problem. Go to [PFW1548: Memory and Processor Problem Isolation](#). If you were sent here because the system is hanging on a partition firmware checkpoint, and the hang condition did not change as a result of the slow boot, go to [PFW1542-520-5](#).

YES

Restore fast boot on the power on/off system menu from the ASMI. Look up the new error code in the reference code index and perform the listed actions.

- PFW1542-520-4

The system stopped with the please define the system console prompt on the system console. Standalone diagnostics can be booted. Perform the following:

1. Follow the instructions on the screen to select the system console.
2. When the DIAGNOSTIC OPERATING INSTRUCTIONS screen is displayed, press Enter.
3. If the terminal type has not been defined, you must use the Initialize Terminal option on the FUNCTION SELECTION menu to initialize the AIX operating system environment before you can continue with the diagnostics. This is a separate operation from selecting the firmware console.
4. Select Advanced Diagnostic Routines.
5. When the DIAGNOSTIC MODE SELECTION menu displays, select System Verification to run diagnostics on all resources.

**Did running diagnostics produce a different symptom?**

NO

Go to step 6 of PFW1542-520-6

YES

Go to the [Start-of-Call Procedure](#). Use the new symptom.

6. Record any devices missing from the list of all adapters and devices. Continue with this procedure. When you have fixed the problem, use this record to verify that all devices appear when you run system verification.

**Are there any devices missing from the list of all adapters and devices?**

NO

Reinstall all remaining adapters, if any, and reconnect all devices. Return the system to its original configuration. Be sure to select fast boot on the power on/off system menu on the ASMI. Go to [MAP 0410: Repair checkout](#).

YES

The boot attempts that follow will attempt to isolate any remaining I/O subsystem problems with missing devices. Ignore any codes that may display on the operator panel unless stated otherwise. Continue to [PFW1542-520-5](#).

- PFW1542-520-5

Examine RIO port 0 on the base system at Un-P1-T3.

**Are there any I/O subsystems attached to the base system?**

NO

Go to [PFW1542-520-22](#).

YES

Continue to [PFW1542-520-6](#).

- PFW1542-520-6

There may be devices missing from one of more of the I/O subsystems.

**Attention:** The 50/94 expansion unit and the 11D/20 I/O subsystem may both be connected to the ESCALA PL 250T/R. The 11D/20 I/O subsystem is a full-width rack-mounted drawer; the 50/94 can be either a tower or a full-width drawer.

The RIO ports on these subsystems are:

|            | 50/94 | 11D/20                        |
|------------|-------|-------------------------------|
| RIO port 0 |       | Un-CB1-C08-01 (top connector) |



|            |                                  |                              |
|------------|----------------------------------|------------------------------|
|            | Un-CB1-C08-00 (bottom connector) |                              |
| RIO port 1 | Un-CB1-C08-01 (top connector)    | Un-P1-C05-01 (top connector) |

**Note:** Before continuing, check the cabling from the base system to the I/O subsystem(s) to insure that the system is cabled correctly. Refer to [Connect your unit with HSL/RIO cables](#) for valid configurations. Record the current cabling configuration and then continue with the following steps.

1. Turn off the power.
2. At the base system, disconnect the cable connection at RIO port 0 (Un-P1-T3).
3. At the other end of the RIO cable referred to in step 2 of PFW1542-520-6, disconnect the I/O subsystem port connector 0 (Un-CB1-C08-00 (bottom connector) or Un-P1-C05-00 (bottom connector) , depending on the I/O subsystem). The RIO cable that was connected to RIO port 0 in the base system should now be loose; remove it. Record the location of this I/O subsystem and call it "subsystem #1".
4. Examine the connection at the I/O port connector 1 (Un-CB1-C08-01 (top connector) or Un-P1-C05-01 (top connector)) of the I/O subsystem recorded in step 3 of PFW1542-520-6. If the RIO cable attached to I/O port connector 1 connects to the I/O port connector 0 of another I/O subsystem, record the location of the next I/O subsystem that is connected to I/O port 1 of subsystem #1, then go to step 9 of PFW1542-520-6.
5. This step is reserved.
6. At the base system, disconnect the cable connection at RIO port 1 (Un-P1-T4) and reconnect it to RIO port 0 (Un-P1-T3).
7. At the I/O subsystem recorded in step 3 of PFW1542-520-6, disconnect the I/O port connector 1 (Un-CB1-C08-01 (top connector) or Un-P1-C05-01 (top connector)) and reconnect to I/O port 0 (Un-CB1-C08-00 (bottom connector) or Un-P1-C05-00 (bottom connector)).
8. Verify that a single RIO cable connects base system RIO port 0 (Un-P1-T3) to the I/O subsystem recorded in step 4 of PFW1542-520-6 port 0 (Un-CB1-C08-00 (bottom connector) or Un-P1-C05-00 (bottom connector)). Go to step 21 of PFW1542-520-6.
9. Record the location of the next I/O subsystem and call it "subsystem #2". This is the I/O subsystem that is connected to I/O port 1 of subsystem #1.
10. Examine the connection at the I/O port 1 (Un-CB1-C08-01 (top connector) or Un-P1-C05-01 (top connector)) of subsystem #2 recorded in step 9 of PFW1542-520-6. If the RIO cable attached to I/O port 1 connects to the I/O port 0 of another I/O subsystem, record the location of the next I/O subsystem that is connected to I/O port 1 of subsystem #2 and call it "subsystem #3". Go to step 14 of PFW1542-520-6.
11. The RIO cable attached to the I/O port 1 (Un-CB1-C08-01 (top connector) or Un-P1-C05-01 (top connector)) of subsystem #2 is attached to port 1 (Un-P1-T4) of the base system. At the base system, disconnect the cable connection at RIO port 1 (Un-P1-T4) and reconnect it to RIO port 0 (Un-P1-T3).
12. On subsystem #2, disconnect the cable from I/O port 1 (Un-CB1-C08-01 (top connector) or Un-P1-C05-01 (top connector)) and reconnect it to I/O port 0 (Un-CB1-C08-00 (bottom connector) or Un-P1-C05-00 (bottom connector)) of subsystem #1.
13. Verify that a single RIO cable connect base system RIO port 0 to one or two I/O subsystems. Go to step 21 of PFW1542-520-6.
14. Examine the connection at the I/O port 1 (Un-CB1-C08-01 (top connector) or Un-P1-C05-01 (top connector)) of subsystem #3 recorded in step 10 of PFW1542-520-6. If the RIO cable attached to I/O port 1 connects to the I/O port 0 of another I/O subsystem, record the location of the next I/O subsystem that is connected to I/O port 1 of the subsystem #3 and call it "subsystem #4". Go to step 18 of PFW1542-520-6.
15. The RIO cable attached to the I/O port 1 (Un-CB1-C08-01 (top connector) or Un-P1-C05-01 (top connector)) of subsystem #3 is attached to port 1 (Un-P1-T4) of the base system. At the base system, disconnect the cable connection at RIO port 1 (Un-P1-T4) and reconnect it to RIO port 0 (Un-P1-T3).
16. On subsystem #3, disconnect the cable from I/O port 1 (Un-CB1-C08-01 (top connector) or Un-P1-C05-01 (top connector)) and reconnect it to I/O port 0 (Un-CB1-C08-00 (bottom connector) or Un-P1-C05-00 (bottom connector)) of subsystem #1.
17. Verify that a single RIO cable connects base system RIO port 0 to three I/O subsystems. Go to step 21 of PFW1542-520-6. The RIO cable attached to the I/O port 1 (Un-CB1-C08-01 (top connector) or Un-P1-C05-01 (top connector)) of subsystem #4 is attached to port 1

(Un-P1-T4) of the base system. At the base system, disconnect the cable connection at RIO port 1 (Un-P1-T4) and reconnect it to RIO port 0 (Un-P1-T3).

18. On subsystem #4, disconnect the cable from I/O port 1 (Un-CB1-C08-01 (top connector) or Un-P1-C05-01 (top connector)) and reconnect it to I/O port 0 (Un-CB1-C08-00 (bottom connector) or Un-P1-C05-00 (bottom connector)) of subsystem #1.
19. Verify that a single RIO cable connects base system RIO port 0 to four I/O subsystems. Continue to step 21 of PFW1542-520-6.
20. Turn on the power to boot the standalone AIX diagnostics from CD-ROM.
21. If the Please define the System Console screen is displayed, follow the directions to select the system console.
22. Use the Display Configuration and Resource List option to list all of the attached devices and adapters.
23. Verify that all adapters and the attached devices are listed.

**Did the Please define the System Console screen display and are all adapters and attached devices listed?**

NO

Go to [PFW1542-520-7](#).

YES

The RIO cable that was removed in step 3 of PFW1542-520-6 is defective. Replace this RIO cable.

- If four I/O subsystems are chained to RIO port 0 (Un-P1-T3) of the base system, connect the new RIO cable from subsystem #4 I/O port 1 (Un-CB1-C08-01 (top connector) or Un-P1-C05-01 (top connector)) to base system RIO port 1 (Un-P1-T4).
  - If three I/O subsystems are chained to RIO port 0 (Un-P1-T3) of the base system, connect the new RIO cable from subsystem #3 I/O port 1 (Un-CB1-C08-01 (top connector) or Un-P1-C05-01 (top connector)) to base system RIO port 1 (Un-P1-T4).
  - If two I/O subsystems are chained to RIO port 0 (Un-P1-T3) of the base system, connect the new RIO cable from subsystem #2 I/O port 1 (Un-CB1-C08-01 (top connector) or Un-P1-C05-01 (top connector)) to base system RIO port 1 (Un-P1-T4).
  - If one I/O subsystem is chained to RIO port 0 (Un-P1-T3) of the base system, connect the new RIO cable from subsystem #1 I/O port 1 (Un-CB1-C08-01 (top connector) or Un-P1-C05-01 (top connector)) to base system RIO port 1 (Un-P1-T4).
- Restore the system back to its original configuration. Go to [MAP 0410: Repair Checkout](#).

• PFW1542-520-7

The I/O in the base system will now be isolated. Power down the system. Disconnect the cable connection at RIO port 0 (Un-P1-T3) of the base system.

• PFW1542-520-8

1. Turn on the power to boot the standalone diagnostic CD-ROM.
2. If the Please define the System Console screen is displayed, follow the directions to select the system console.
3. Use the Display Configuration and Resource List option to list all of the attached devices and adapters.
4. Check that all adapters and attached devices in the base system are listed.

If the Please define the System Console screen was not displayed or all adapters and attached devices are not listed, the problem is in the base system.

**Was the Please define the System Console screen displayed and were all adapters and attached devices listed?**

NO

Go to [PFW1542-520-22](#).

YES

Go to [PFW1542-520-21](#).

• PFW1542-520-9

For subsystem #1:

- ◆ Are there any adapters in slots 1, 2, 3, 4, 5, or 6 if it is a 11D/20?
- ◆ Are there any adapters in slots 1, 2, 3, 4, 5, 6, 7, 8, 9, 11, 12, 13, 14, or 15 if it is a 50/94?

NO

Go to [PFW1542-520-10](#).

YES

Go to [PFW1542-520-13](#).

• PFW1542-520-10

For subsystem #2:

- ◆ Are there any adapters in slots 1, 2, 3, 4, 5, or 6 if it is a 11D/20?
- ◆ Are there any adapters in slots 1, 2, 3, 4, 5, 6, 7, 8, 9, 11, 12, 13, 14, or 15 if it is a 50/94?

NO

Go to [PFW1542-520-11](#).

YES

Go to [PFW1542-520-14](#).

- PFW1542-520-11

For subsystem #3:

- ◆ Are there any adapters in slots 1, 2, 3, 4, 5, or 6 if it is a 11D/20?
- ◆ Are there any adapters in slots 1, 2, 3, 4, 5, 6, 7, 8, 9, 11, 12, 13, 14, or 15 if it is a 50/94?

NO

Go to [PFW1542-520-12](#).

YES

Go to [PFW1542-520-15](#).

- PFW1542-520-12

For subsystem #4:

- ◆ Are there any adapters in slots 1, 2, 3, 4, 5, or 6 if it is a 11D/20?
- ◆ Are there any adapters in slots 1, 2, 3, 4, 5, 6, 7, 8, 9, 11, 12, 13, 14, or 15 if it is a 50/94?

NO

Go to [PFW1542-520-20](#).

YES

Go to [PFW1542-520-16](#).

- PFW1542-520-13

1. If it is not already off, turn off the power.
2. Label and record the locations of any cables attached to the adapters, then disconnect the cables.
3. Record the slot numbers of the adapters.
4. Remove all adapters from slots 1, 2, 3, 4, 6, and 7 in the I/O subsystem if it is a 11D/20, or from slot 1-9 and 11-15 if it is a 50/94.
5. Turn on the power to boot the standalone diagnostic CD-ROM.
6. If the ASCII terminal displays Enter 0 to select this console, press the 0 (zero) key on the ASCII terminal's keyboard.
7. If the Please define the System Console screen is displayed, follow the directions to select the system console.
8. Use the Display Configuration and Resource List option to list all adapters and attached devices.
9. Check that all adapters and attached devices are listed.

**Was the Please define the System Console screen displayed and were all adapters and attached devices listed?**

NO

Go to [PFW1542-520-10](#).

YES

Go to [PFW1542-520-17](#).

- PFW1542-520-14

1. If it is not already off, turn off the power.
2. Label and record the locations of any cables attached to the adapters, then disconnect the cables.
3. Record the slot numbers of the adapters.
4. Remove all adapters from slots 1, 2, 3, 4, 6, and 7 in the I/O subsystem if it is a 11D/20, or from slot 1-9 and 11-15 if it is a 50/94.
5. Turn on the power to boot the standalone diagnostic CD-ROM.
6. If the ASCII terminal displays Enter 0 to select this console, press the 0 (zero) key on the ASCII terminal's keyboard.
7. If the Please define the System Console screen is displayed, follow the directions to select the system console.
8. Use the Display Configuration and Resource List option to list all adapters and attached devices.
9. Check that all adapters and attached devices are listed.

**Was the Please define the System Console screen displayed and were all adapters and attached devices listed?**

NO

Go to [PFW1542-520-11](#).

YES

Go to [PFW1542-520-17](#).

## • PFW1542-520-15

1. If it is not already off, turn off the power.
2. Label and record the locations of any cables attached to the adapters, then disconnect the cables.
3. Record the slot numbers of the adapters.
4. Remove all adapters from slots 1, 2, 3, 4, 6, and 7 in the I/O subsystem if it is a 11D/20, or from slot 1-9 and 11-15 if it is a 50/94.
5. Turn on the power to boot the standalone diagnostic CD-ROM.
6. If the ASCII terminal displays Enter 0 to select this console, press the 0 (zero) key on the ASCII terminal's keyboard.
7. If the Please define the System Console screen is displayed, follow the directions to select the system console.
8. Use the Display Configuration and Resource List option to list all adapters and attached devices.
9. Check that all adapters and attached devices are listed.

**Was the Please define the System Console screen displayed and were all adapters and attached devices listed?**

NO

Go to [PFW1542-520-12](#).

YES

Go to [PFW1542-520-17](#).

## • PFW1542-520-16

1. If it is not already off, turn off the power.
2. Label and record the locations of any cables attached to the adapters, then disconnect the cables.
3. Record the slot numbers of the adapters.
4. Remove all adapters from slots 1, 2, 3, 4, 6, and 7 in the I/O subsystem if it is a 11D/20, or from slots 1-9 and 11-15 if it is a 50/94.
5. Turn on the power to boot the standalone diagnostic CD-ROM.
6. If the ASCII terminal displays Enter 0 to select this console, press the 0 (zero) key on the ASCII terminal's keyboard.
7. If the Please define the System Console screen is displayed, follow the directions to select the system console.
8. Use the Display Configuration and Resource List option to list all adapters and attached devices.
9. Check that all adapters and attached devices are listed.

**Was the Please define the System Console screen displayed and were all adapters and attached devices listed?**

NO

Go to [PFW1542-520-19](#).

YES

Go to [PFW1542-520-17](#).

## • PFW1542-520-17

If the Please define the System Console screen was not displayed and all adapters and attached devices were not listed, the problem is with one of the adapter cards or attached devices that was removed or disconnected from the I/O subsystem.

1. Turn off the power.
2. Reinstall one adapter and device that was removed. Use the original adapter cards in their original slots when reinstalling adapters.
3. Turn on the power to boot the standalone diagnostic CD-ROM.
4. If the Please define the System Console screen is displayed, follow the directions to select the system console.
5. Use the Display Configuration and Resource List option to list all adapters and attached devices.
6. Check that all adapters and attached devices are listed.

**Was the Please define the System Console screen displayed and were all adapters and attached devices listed?**

NO

Go to [PFW1542-520-18](#).

YES

Reinstall the next adapter and device and return to the beginning of this step. Repeat this process until an adapter or device causes the Please define the System Console screen to not display or all attached devices and adapters to not be listed.

After installing all of the adapters and the Please define the System Console screen does display and all attached devices and adapters are listed, return the system to its original configuration. Go to [MAP 0410: Repair Checkout](#).

• PFW1542-520-18

Replace the adapter you just installed with a new adapter and retry booting AIX standalone diagnostics from CD-ROM.

1. If the Please define the System Console screen is displayed, follow the directions to select the system console.
2. Use the Display Configuration and Resource List option to list all adapters and attached devices.
3. Check that all adapters and attached devices are listed.

**Was the Please define the System Console screen displayed and were all adapters and attached devices listed?**

NO

The I/O subsystem backplane is defective. Replace the I/O subsystem backplane. In both the 11D/20 and the 50/94, the I/O subsystem backplane is Un-CB1. Then go to [PFW1542-520-20](#).

YES

The adapter was defective. Go to [PFW1542-520-20](#).

• PFW1542-520-19

1. Turn off the power.
2. Disconnect the I/O subsystem power cables.
3. Replace the following parts, one at a time, if present, in the sequence listed:
  - a. I/O subsystem #1 backplane, Un-CB1.
  - b. I/O subsystem #2 backplane, Un-CB1.
  - c. I/O subsystem #3 backplane, Un-CB1.
  - d. I/O subsystem #4 backplane, Un-CB1.
4. Reconnect the I/O subsystem power cables.
5. Turn on the power.
6. Boot standalone AIX diagnostics from CD.
7. If the Please define the System Console screen is displayed, follow directions to select the system console.
8. Use the Display Configuration and Resource List option to list all adapters and attached devices.
9. Check that all attached devices and adapters are listed.

**Did the Please define the System Console screen display and are all attached devices and adapters listed?**

NO

Replace the next part in the list and return to the beginning of this step. Repeat this process until a part causes the Please define the System Console screen to be displayed and all adapters and attached devices to be listed. If you have replaced all the items listed above and the Please define the System Console screen does not display or all attached devices and adapters are not listed, check all external devices and cabling. If you do not find a problem, contact your next level of support for assistance.

YES

Go to [PFW1542-520-20](#).

• PFW1542-520-20

1. Turn off the power.
2. The item just replaced fixed the problem.
3. If a display adapter with keyboard and mouse were installed, reinstall the display adapter card, keyboard, and mouse.
4. Reconnect the tape drive (if previously installed) to the internal SCSI bus cable.
5. Plug in all adapters that were previously removed but not reinstalled.
6. Reconnect the I/O subsystem power cables that were previously disconnected.

Return the system to its original condition. Go to [MAP 0410: Repair Checkout](#).

• PFW1542-520-21

1. Turn off the power.
2. At the base system, reconnect the cable connection at RIO port 0 (Un-P1-T3) recorded in [PFW1542-520-6](#).
3. At the base system, reconnect the cable connection at RIO port 1 (Un-P1-T4) recorded in [PFW1542-520-6](#).
4. Reconnect the power cables to the I/O subsystems that were found attached to the base system RIO ports mentioned in step 2 and step 3 of PFW1542-520-21. All I/O subsystems that were attached to the base system RIO port 0 and RIO port 1 should now be reconnected to the base system.
5. Make sure the I/O subsystem(s) are cabled correctly as shown in [Connect your unit with HSL/RIO cables](#).
6. Turn on the power to boot standalone AIX diagnostics from CD-ROM.
7. If the Please define the System Console screen is displayed, follow the directions to select the system console.
8. Use the Display Configuration and Resource List option to list all adapters and attached devices.
9. Check that all adapters and attached devices are listed.

**Did the Please define the System Console screen display and are all attached devices and adapters listed?**

NO

Go to [PFW1542-520-9](#) to isolate a problem in an I/O subsystem attached to the base system RIO bus on the system backplane.

YES

Go to [PFW1542-520-20](#).

- PFW1542-520-22

**Are there any adapters in slots 1, 2, 3, 4, 5, or 6 in the base system?**

NO

Go to [PFW1542-520-23](#).

YES

Go to [PFW1542-520-25](#).

- PFW1542-520-23

Replace the system backplane, Un-P1. Go to [MAP 0410: Repair Checkout](#).

- PFW1542-520-24

1. Boot standalone AIX diagnostics from CD.
2. If the Please define the System Console screen is displayed, follow directions to select the system console.
3. Use the Display Configuration and Resource List to list all adapters and attached devices.
4. Check that all adapters and attached devices are listed.

**Did the Please define the System Console screen display and are all attached devices and adapters listed?**

NO

Go to [PFW1542-520-28](#).

YES

Go to [PFW1542-520-20](#).

- PFW1542-520-25

1. If it is not already off, turn off the power.
2. Label and record the location of any cables attached to the adapters.
3. Record the slot number of the adapters.
4. Remove all adapters from slots 1, 2, 3, 4, 5, and 6 in the base system that are not attached to the boot device.
5. Turn on the power to boot standalone diagnostics from CD-ROM.
6. If the ASCII terminal displays Enter 0 to select this console, press the 0 key on the ASCII terminal's keyboard.
7. If the Please define the System Console screen is displayed, follow directions to select the system console.
8. Use the Display Configuration and Resource List option to list all adapters and attached devices.
9. Check that all adapters and attached devices are listed.

**Did the Please define the System Console screen display and are all attached devices and adapters listed?**

NO

Go to [PFW1542-520-23](#).

YES

Go to [PFW1542-520-26](#).

• PFW1542-520-26

If the Please define the System Console screen does display and all adapters and attached devices are listed, the problem is with one of the adapter cards or devices that was removed or disconnected from the base system.

1. Turn off the power.
2. Reinstall one adapter and device that was removed. Use the original adapter cards in their original slots when reinstalling adapters.
3. Turn on the power to boot standalone diagnostics from CD-ROM.
4. If the Please define the System Console screen is displayed, follow the directions to select the system console.
5. Use the Display Configuration and Resource List to list all adapters and attached devices.
6. Check that all adapters and attached devices are listed.

**Did the Please define the System Console screen display and are all attached devices and adapters listed?**

NO

Go to [PFW1542-520-27](#).

YES

Reinstall the next adapter and device and return to the beginning of this step. Repeat this process until an adapter and device causes the Please define the System Console screen to not display or all attached devices and adapters to not be listed. After installing all of the adapters and the Please define the System Console screen displays and all attached devices and adapters are listed, go to [PFW1542-520-20](#).

• PFW1542-520-27

Replace the adapter you just installed with a new adapter and retry the boot to standalone AIX diagnostics from CD-ROM.

1. If the Please define the System Console screen is displayed, follow directions to select the system console.
2. Use the Display Configuration and Resource List option to list all adapters and attached devices.
3. Check that all adapters and attached devices are listed.

**Did the Please define the System Console screen display and are all attached devices and adapters listed?**

NO

Go to [PFW1542-520-23](#).

YES

Go to [PFW1542-520-20](#).

• PFW1542-520-28

1. Turn off the power
2. Disconnect the base system power cables.
3. Replace the following parts, one at a time, in the sequence listed:
  - a. Internal SCSI cable
  - b. Disk drive backplanes, one at a time
  - c. Media backplane
  - d. IDE devices, one at a time
  - e. SCSI devices, one at a time
  - f. Service processor
4. Reconnect the base system power cables.
5. Turn on the power.
6. Boot standalone AIX diagnostics from CD.
7. If the Please define the System Console screen is displayed, follow directions to select the system console.
8. Use the Display Configuration and Resource List option to list all adapters and attached devices.
9. Check that all adapters and attached devices are listed.

**Did the Please define the System Console screen display and are all adapters and attached devices listed?**

NO

Replace the next part in the list and return to the beginning of this step. Repeat this process until a part causes the Please define the System Console screen to be displayed and all adapters and attached devices to be listed. If you have replaced all the items listed above and the Please define the System Console screen does not display or all adapters and attached devices are not listed, check all external devices and cabling. If you do not find a problem, contact your next level of support for assistance.

YES

Go to [PFW1542-520-20](#).

## PFW1542-550: I/O problem isolation procedure for model ESCALA PL 450T/R, ESCALA PL 450T/R+ or ESCALA PL 850T/R-L+,

Use this procedure to locate defective FRUs not found by normal diagnostics.

### Purpose of this procedure

Use this procedure to locate defective FRUs not found by normal diagnostics when servicing an ESCALA PL 450T/R. For this procedure, diagnostics are run on a minimally configured system. If a failure is detected on the minimally configured system, the remaining FRUs are exchanged one at a time until the failing FRU is identified. If a failure is not detected, FRUs are added back until the failure occurs. The failure is then isolated to the failing FRU.

- PFW1542-550-1
  1. Insure that the diagnostics and the operating system are shut down.
  2. Turn off the power.
  3. Select slow system boot speed on the power on/off system menu under the power/restart control menu on the ASMI.
  4. Turn on the power.
  5. Put the AIX diagnostic CD-ROM into the optical drive.

#### Does the optical drive appear to operate correctly?

NO

Go to [Problems with Loading and Starting the Operating System](#)

YES

Continue to [PFW1542-550-2](#).

- PFW1542-550-2
  1. When the keyboard indicator is displayed (the word keyboard), if the system or partition gets that far in the IPL process, press the 5 key on the firmware console.
  2. Enter the appropriate password if you are prompted to do so.

#### Is the Please define the System Console screen displayed?

NO

Continue to [PFW1542-550-3](#).

YES

Go to [PFW1542-550-4](#).

- PFW1542-550-3

The system is unable to boot standalone AIX diagnostics. Check the service processor error log (using the ASMI) and the operator panel for additional error codes resulting from the slow boot that was performed in PFW1542-550-1.

#### Did the slow boot generate a different error code or partition firmware hang from the one that originally sent you to PFW1542?

NO

If you were sent here by an error code, and the error code did not change as the result of a slow boot, you have a processor subsystem problem. Go to [PFW1548: Memory and Processor Problem Isolation](#). If you were sent here because the system is hanging on a partition firmware checkpoint, and the hang condition did not change as a result of the slow boot, go to [PFW1542-550-5](#).

YES



Restore fast boot on the power on/off system menu from the ASMI. Look up the new error code in the reference code index and perform the listed actions.

- PFW1542-550-4

The system stopped with the please define the system console prompt on the system console. Standalone diagnostics can be booted. Perform the following:

1. Follow the instructions on the screen to select the system console.
2. When the DIAGNOSTIC OPERATING INSTRUCTIONS screen is displayed, press Enter.
3. If the terminal type has not been defined, you must use the Initialize Terminal option on the FUNCTION SELECTION menu to initialize the AIX operating system environment before you can continue with the diagnostics. This is a separate operation from selecting the firmware console.
4. Select Advanced Diagnostic Routines.
5. When the DIAGNOSTIC MODE SELECTION menu displays, select System Verification to run diagnostics on all resources.

**Did running diagnostics produce a different symptom?**

NO

Go to [step 6](#) of PFW1542-550-4.

YES

Go to the [Start-of-Call procedure](#). Use the new symptom.

6. Record any devices missing from the list of all adapters and devices. Continue with this procedure. When you have fixed the problem, use this record to verify that all devices appear when you run system verification.

**Are there any devices missing from the list of all adapters and devices?**

NO

Reinstall all remaining adapters, if any, and reconnect all devices. Return the system to its original configuration. Be sure to select fast boot on the power on/off system menu on the ASMI. Go to Repair Checkout.

YES

The boot attempts that follow will attempt to isolate any remaining I/O subsystem problems with missing devices. Ignore any codes that may display on the operator panel unless stated otherwise. Continue to [PFW1542-550-5](#).

- PFW1542-550-5

Examine RIO port 0 on the base system at Un-P1-T11.

**Are there any I/O subsystems attached to the base system?**

NO

Go to [PFW1542-550-25](#).

YES

Continue to [PFW1542-550-6](#).

- PFW1542-550-6

There may be devices missing from one of more of the I/O subsystems, or one or more devices in the I/O subsystems may be causing the system or a partition to hang during IPL.

**Attention:** The 50/94 expansion unit and the 11D/20 I/O subsystem may both be connected to the ESCALA PL 450T/R. The 11D/20 I/O subsystem is a full-width rack-mounted drawer; the 50/94 can be either a tower or a full-width drawer.

The RIO ports on these subsystems are:

|  |                                       |              |               |
|--|---------------------------------------|--------------|---------------|
|  | <b>ESCALA PL 450T/R (base system)</b> | <b>50/94</b> | <b>11D/20</b> |
|--|---------------------------------------|--------------|---------------|

|            |           |                                  |                                 |
|------------|-----------|----------------------------------|---------------------------------|
| RIO port 0 | Un-P1-T11 | Un-CB1-C08-00 (bottom connector) | Un-P1-C05-00 (bottom connector) |
| RIO port 1 | Un-P1-T12 | Un-CB1-C08-01 (top connector)    | Un-P1-C05-01 (top connector)    |

**Note:** Before continuing, check the cabling from the base system to the I/O subsystem(s) to insure that the system is cabled correctly. Refer to [Connect your unit with HSL/RIO cables](#) for valid configurations. Record the current cabling configuration and then continue with the following steps.

1. Turn off the power.
2. At the base system, disconnect the cable connection at RIO port 0 (Un-P1-T11).
3. At the other end of the RIO cable referred to in step 2, disconnect the I/O subsystem port connector 0 (Un-CB1-C08-00 (bottom connector) or Un-P1-C05-00 (bottom connector), depending on the I/O subsystem). The RIO cable that was connected to RIO port 0 in the base system should now be loose; remove it. Record the location of this I/O subsystem and call it "subsystem #1".
4. Examine the connection at the I/O port connector 1 (Un-CB1-C08-01 (top connector) or Un-P1-C05-01 (top connector) of the I/O subsystem recorded in [step 3](#) of PFW1542-550-6. If the RIO cable attached to I/O port connector 1 connects to the I/O port connector 0 of another I/O subsystem, record the location of the next I/O subsystem that is connected to I/O port 1 of subsystem #1, then go to [step 9](#) of PFW1542-550-6.
5. This step is reserved.
6. At the base system, disconnect the cable connection at RIO port 1 (Un-P1-T12) and reconnect it to RIO port 0 (Un-P1-T11).
7. At the I/O subsystem recorded in [step 3](#) of PFW1542-550-6, disconnect the I/O port connector 1 (Un-CB1-C08-01 (top connector) or Un-P1-C05-01 (top connector)) and reconnect to I/O port 0 (Un-CB1-C08-00 (bottom connector) or Un-P1-C05-00 (bottom connector)).
8. Verify that a single RIO cable connects base system RIO port 0 (Un-P1-T11) to the I/O subsystem recorded in [step 4](#) of PFW1542-550-6 port 0 (Un-CB1-C08-00 (bottom connector) or Un-P1-C05-00 (bottom connector)). Go to [step 21](#) of PFW1542-550-6.
9. Record the location of the next I/O subsystem and call it "subsystem #2". This is the I/O subsystem that is connected to I/O port 1 of subsystem #1.
10. Examine the connection at the I/O port 1 (Un-CB1-C08-01 (top connector) or Un-P1-C05-01 (top connector)) of subsystem #2 recorded in [step 9](#) of PFW1542-550-6. If the RIO cable attached to I/O port 1 connects to the I/O port 0 of another I/O subsystem, record the location of the next I/O subsystem that is connected to I/O port 1 of subsystem #2 and call it "subsystem #3". Go to [step 14](#) of PFW1542-550-6.
11. The RIO cable attached to the I/O port 1 (Un-CB1-C08-01 (top connector) or Un-P1-C05-01 (top connector)) of subsystem #2 is attached to port 1 (Un-P1-T12) of the base system. At the base system, disconnect the cable connection at RIO port 1 (Un-P1-T12) and reconnect it to RIO port 0 (Un-P1-T11).
12. On subsystem #2, disconnect the cable from I/O port 1 (Un-CB1-C08-01 (top connector) or Un-P1-C05-01 (top connector)) and reconnect it to I/O port 0 (Un-CB1-C08-00 (bottom connector) or Un-P1-C05-00 (bottom connector)) of subsystem #1.
13. Verify that a single RIO cable connect base system RIO port 0 to one or two I/O subsystems. Go to [step 21](#) of PFW1542-550-6.
14. Examine the connection at the I/O port 1 (Un-CB1-C08-01 (top connector) or Un-P1-C05-01 (top connector)) of subsystem #3 recorded in [step 10](#) of PFW1542-550-6. If the RIO cable attached to I/O port 1 connects to the I/O port 0 of another I/O subsystem, record the location of the next I/O subsystem that is connected to I/O port 1 of the subsystem #3 and call it "subsystem #4". Go to [step 18](#) of PFW1542-550-6.
15. The RIO cable attached to the I/O port 1 (Un-CB1-C08-01 (top connector) or Un-P1-C05-01 (top connector)) of subsystem #3 is attached to port 1 (Un-P1-T12) of the base system. At the base system, disconnect the cable connection at RIO port 1 (Un-P1-T12) and reconnect it to RIO port 0 (Un-P1-T11).
16. On subsystem #3, disconnect the cable from I/O port 1 (Un-CB1-C08-01 (top connector) or Un-P1-C05-01 (top connector)) and reconnect it to I/O port 0 (Un-CB1-C08-00 (bottom connector) or Un-P1-C05-00 (bottom connector)) of subsystem #1.
17. Verify that a single RIO cable connects base system RIO port 0 to three I/O subsystems. Go to [step 21](#) of PFW1542-550-6.

18. The RIO cable attached to the I/O port 1 (Un-CB1-C08-01 (top connector) or Un-P1-C05-01 (top connector)) of subsystem #4 is attached to port 1 (Un-P1-T12) of the base system. At the base system, disconnect the cable connection at RIO port 1 (Un-P1-T12) and reconnect it to RIO port 0 (Un-P1-T11).
19. On subsystem #4, disconnect the cable from I/O port 1 (Un-CB1-C08-01 (top connector) or Un-P1-C05-01 (top connector)) and reconnect it to I/O port 0 (Un-CB1-C08-00 (bottom connector) or Un-P1-C05-00 (bottom connector)) of subsystem #1.
20. Verify that a single RIO cable connects base system RIO port 0 to four I/O subsystems. Continue to [step 21](#) of PFW1542-550-6. Turn on the power to boot the standalone AIX diagnostics from CD-ROM.
21. If the Please define the System Console screen is displayed, follow the directions to select the system console.
22. Use the Display Configuration and Resource List option to list all of the attached devices and adapters.
23. Verify that all adapters and the attached devices are listed.

**Did the Please define the System Console screen display and are all adapters and attached devices listed?**

NO

Go to [PFW1542-550-7](#).

YES

Replace the RIO cable that was removed in [step 3](#) of PFW1542-550-6.

**Notes:**

1. If four I/O subsystems are chained to RIO port 0 (Un-P1-T11) of the base system, connect the new RIO cable from subsystem #4 I/O port 1 (Un-CB1-C08-01 (top connector) or Un-P1-C05-01 (top connector)) to base system RIO port 1 (Un-P1-T12).
2. If three I/O subsystems are chained to RIO port 0 (Un-P1-T11) of the base system, connect the new RIO cable from subsystem #3 I/O port 1 (Un-CB1-C08-01 (top connector) or Un-P1-C05-01 (top connector)) to base system RIO port 1 (Un-P1-T12).
3. If two I/O subsystems are chained to RIO port 0 (Un-P1-T11) of the base system, connect the new RIO cable from subsystem #2 I/O port 1 (Un-CB1-C08-01 (top connector) or Un-P1-C05-01 (top connector)) to base system RIO port 1 (Un-P1-T12).
4. If one I/O subsystem is chained to RIO port 0 (Un-P1-T11) of the base system, connect the new RIO cable from subsystem #1 I/O port 1 (Un-CB1-C08-01 (top connector) or Un-P1-C05-01 (top connector)) to base system RIO port 1 (Un-P1-T12).

Restore the system back to its original configuration. Go to [MAP 0410: Repair checkout](#).

- PFW1542-550-7

The I/O attached to the RIO ports on the base system planar will now be isolated. Power down the system. Disconnect the cable connection at RIO port 0 (Un-P1-T11) of the base system.

- PFW1542-550-8

1. Turn on the power to boot the standalone diagnostic CD-ROM.
2. If the Please define the System Console screen is displayed, follow the directions to select the system console.
3. Use the Display Configuration and Resource List option to list all of the attached devices and adapters.
4. Check that all adapters and attached devices in the base system are listed. If the Please define the System Console screen was not displayed or all adapters and attached devices are not listed, the problem is in the base system.

**Was the Please define the System Console screen displayed and were all adapters and attached devices listed?**

NO

Go to [PFW1542-550-25](#).

YES

Go to [PFW1542-550-21](#).

- PFW1542-550-9

For subsystem #1:

**Are there any adapters in slots 1, 2, 3, 4, 5, or 6 if it is a 11D/20?**

OR

**Are there any adapters in slots 1, 2, 3, 4, 5, 6, 7, 8, 9, 11, 12, 13, 14, or 15 if it is a 50/94?**

NO

Go to [PFW1542-550-10](#).

YES

Go to [PFW1542-550-13](#).

- PFW1542-550-10

For subsystem #2:

**Are there any adapters in slots 1, 2, 3, 4, 5, or 6 if it is a 11D/20?**

OR

**Are there any adapters in slots 1, 2, 3, 4, 5, 6, 7, 8, 9, 11, 12, 13, 14, or 15 if it is a 50/94?**

NO

Go to [PFW1542-550-11](#).

YES

Go to [PFW1542-550-14](#).

- PFW1542-550-11

For subsystem #3:

**Are there any adapters in slots 1, 2, 3, 4, 5, or 6 if it is a 11D/20?**

OR

**Are there any adapters in slots 1, 2, 3, 4, 5, 6, 7, 8, 9, 11, 12, 13, 14, or 15 if it is a 50/94?**

NO

Go to [PFW1542-550-12](#).

YES

Go to [PFW1542-550-15](#).

- PFW1542-550-12

For subsystem #4:

**Are there any adapters in slots 1, 2, 3, 4, 5, or 6 if it is a 11D/20?**

OR

**Are there any adapters in slots 1, 2, 3, 4, 5, 6, 7, 8, 9, 11, 12, 13, 14, or 15 if it is a 50/94?**

NO

Go to [PFW1542-550-19](#).

YES

Go to [PFW1542-550-16](#).

- PFW1542-550-13
  1. If it is not already off, turn off the power.
  2. Label and record the locations of any cables attached to the adapters, then disconnect the cables.
  3. Record the slot numbers of the adapters.
  4. Remove all adapters from slots 1, 2, 3, 4, 6, and 7 in the I/O subsystem if it is a 11D/20, or from slot 1-9 and 11-15 if it is a 50/94.
  5. Turn on the power to boot the standalone diagnostic CD-ROM.
  6. If the ASCII terminal displays Enter 0 to select this console, press the 0 (zero) key on the ASCII terminal's keyboard.
  7. If the Please define the System Console screen is displayed, follow the directions to select the system console.
  8. Use the Display Configuration and Resource List option to list all adapters and attached devices.
  9. Check that all adapters and attached devices are listed.

**Was the Please define the System Console screen displayed and were all adapters and attached devices listed?**

NO

Go to [PFW1542-550-10](#).

YES

Go to [PFW1542-550-17](#).

## • PFW1542-550-14

1. If it is not already off, turn off the power.
2. Label and record the locations of any cables attached to the adapters, then disconnect the cables.
3. Record the slot numbers of the adapters.
4. Remove all adapters from slots 1, 2, 3, 4, 6, and 7 in the I/O subsystem if it is a 11D/20, or from slot 1-9 and 11-15 if it is a 50/94.
5. Turn on the power to boot the standalone diagnostic CD-ROM.
6. If the ASCII terminal displays Enter 0 to select this console, press the 0 (zero) key on the ASCII terminal's keyboard.
7. If the Please define the System Console screen is displayed, follow the directions to select the system console.
8. Use the Display Configuration and Resource List option to list all adapters and attached devices.
9. Check that all adapters and attached devices are listed.

**Was the Please define the System Console screen displayed and were all adapters and attached devices listed?**

NO

Go to [PFW1542-550-11](#).

YES

Go to [PFW1542-550-17](#).

## • PFW1542-550-15

1. If it is not already off, turn off the power.
2. Label and record the locations of any cables attached to the adapters, then disconnect the cables.
3. Record the slot numbers of the adapters.
4. Remove all adapters from slots 1, 2, 3, 4, 6, and 7 in the I/O subsystem if it is a 11D/20, or from slot 1-9 and 11-15 if it is a 50/94.
5. Turn on the power to boot the standalone diagnostic CD-ROM.
6. If the ASCII terminal displays Enter 0 to select this console, press the 0 (zero) key on the ASCII terminal's keyboard.
7. If the Please define the System Console screen is displayed, follow the directions to select the system console.
8. Use the Display Configuration and Resource List option to list all adapters and attached devices.
9. Check that all adapters and attached devices are listed.

**Was the Please define the System Console screen displayed and were all adapters and attached devices listed?**

NO

Go to [PFW1542-550-12](#).

YES

Go to [PFW1542-550-17](#).

## • PFW1542-550-16

1. If it is not already off, turn off the power
2. Label and record the locations of any cables attached to the adapters, then disconnect the cables.
3. Record the slot numbers of the adapters.
4. Remove all adapters from slots 1, 2, 3, 4, 6, and 7 in the I/O subsystem if it is a 11D/20, or from slots 1-9 and 11-15 if it is a 50/94.
5. Turn on the power to boot the standalone diagnostic CD-ROM.
6. If the ASCII terminal displays Enter 0 to select this console, press the 0 (zero) key on the ASCII terminal's keyboard.
7. If the Please define the System Console screen is displayed, follow the directions to select the system console.
8. Use the Display Configuration and Resource List option to list all adapters and attached devices.
9. Check that all adapters and attached devices are listed.

**Was the Please define the System Console screen displayed and were all adapters and attached devices listed?**

NO

Go to [PFW1542-550-19](#).

YES

Go to [PFW1542-550-17](#).

• PFW1542-550-17

If the Please define the System Console screen was not displayed and all adapters and attached devices were not listed, the problem is with one of the adapter cards or attached devices that was removed or disconnected from the I/O subsystem.

1. Turn off the power.
2. Reinstall one adapter and device that was removed. Use the original adapter cards in their original slots when reinstalling adapters.
3. Turn on the power to boot the standalone diagnostic CD-ROM
4. If the Please define the System Console screen is displayed, follow the directions to select the system console.
5. Use the Display Configuration and Resource List option to list all adapters and attached devices.
6. Check that all adapters and attached devices are listed.

**Was the Please define the System Console screen displayed and were all adapters and attached devices listed?**

NO

Go to [PFW1542-550-18](#).

YES

Reinstall the next adapter and device and return to the beginning of this step. Repeat this process until an adapter or device causes the Please define the System Console screen to not display or all attached devices and adapters to not be listed. After installing all of the adapters and the Please define the System Console screen does display and all attached devices and adapters are listed, return the system to its original configuration. Go to [MAP 0410: Repair Checkout](#).

• PFW1542-550-18

Replace the adapter you just installed with a new adapter and retry booting AIX standalone diagnostics from CD-ROM.

1. If the Please define the System Console screen is displayed, follow the directions to select the system console.
2. Use the Display Configuration and Resource List option to list all adapters and attached devices.
3. Check that all adapters and attached devices are listed.

**Was the Please define the System Console screen displayed and were all adapters and attached devices listed?**

NO

The I/O subsystem backplane is defective. Replace the I/O subsystem backplane. In both the 11D/20 and the 50/94, the I/O subsystem backplane is Un-CB1. Then go to [PFW1542-550-20](#).

YES

The adapter was defective. Go to [PFW1542-550-20](#).

• PFW1542-550-19

1. Turn off the power.
2. Disconnect the I/O subsystem power cables.
3. Replace the following parts, one at a time, if present, in the sequence listed:
  - a. I/O subsystem #1 backplane, Un-CB1.
  - b. I/O subsystem #2 backplane, Un-CB1.
  - c. I/O subsystem #3 backplane, Un-CB1.
  - d. I/O subsystem #4 backplane, Un-CB1.
  - e. The RIO interface in the base system that the RIO cables are presently attached to: either the base planar (Un-P1) if the cables are connected to Un-P1-T11 and Un-P1-T12, or the RIO expansion card (Un-P1-C6) if the RIO cables are attached to Un-P1-C6-T1 and Un-P1-C6-T2.
4. Reconnect the I/O subsystem power cables.
5. Turn on the power.
6. Boot standalone AIX diagnostics from CD.
7. If the Please define the System Console screen is displayed, follow directions to select the system console.

8. Use the Display Configuration and Resource List option to list all adapters and attached devices.
9. Check that all attached devices and adapters are listed.

**Did the Please define the System Console screen display and are all attached devices and adapters listed?**

NO

Replace the next part in the list and return to the beginning of this step. Repeat this process until a part causes the Please define the System Console screen to be displayed and all adapters and attached devices to be listed. If you have replaced all the items listed above and the Please define the System Console screen does not display or all attached devices and adapters are not listed, check all external devices and cabling. If you do not find a problem, contact your next level of support for assistance.

YES

Go to [PFW1542-550-20](#).

- PFW1542-550-20
  1. Turn off the power.
  2. The item just replaced fixed the problem.
  3. If a display adapter with keyboard and mouse were installed, reinstall the display adapter card, keyboard, and mouse.
  4. Reconnect the tape drive (if previously installed) to the internal SCSI bus cable.
  5. Plug in all adapters that were previously removed but not reinstalled.
  6. Reconnect the I/O subsystem power cables that were previously disconnected.
  7. Return the system to its original condition. Go to [MAP 0410: Repair Checkout](#).
- PFW1542-550-21
  1. Turn off the power.
  2. At the base system, reconnect the cable connection at RIO port 0 (Un-P1-T11) recorded in [PFW1542-550-7](#).
  3. At the base system, reconnect the cable connection at RIO port 1(Un-P1-T12) recorded in [PFW1542-550-7](#).
  4. Reconnect the power cables to the I/O subsystems that were found attached to the base system RIO ports mentioned in [Step 2](#) and [Step 3](#) of PFW1542-550-21. All I/O subsystems that were attached to the base system RIO port 0 and RIO port 1 should now be reconnected to the base system.
  5. Make sure the I/O subsystem(s) are cabled correctly as shown in [Connect your unit with HSL/RIO cables](#).
  6. Turn on the power to boot standalone AIX diagnostics from CD-ROM.
  7. If the Please define the System Console screen is displayed, follow the directions to select the system console.
  8. Use the Display Configuration and Resource List option to list all adapters and attached devices.
  9. Check that all adapters and attached devices are listed.

**Did the Please define the System Console screen display and are all attached devices and adapters listed?**

NO

Go to [PFW1542-550-9](#) to isolate a problem in an I/O subsystem attached to the base system RIO bus on the system backplane.

YES

Go to [PFW1542-550-22](#).

- PFW1542-550-22

**Is there a RIO expansion card plugged into Un-P1-C6 in the base system, and if so, is there at least one I/O subsystem attached to it?**

NO

Go to [PFW1542-550-25](#).

YES

Continue to [PFW1542-550-23](#).

- PFW1542-550-23
  1. Turn off the power.
  2. At the base system, reconnect the cable connection at RIO port 0 on the RIO expansion card (Un-P1-C6-T2) recorded in [PFW1542-550-7](#).
  3. At the base system, reconnect the cable connection at RIO port 1 on the RIO expansion card (Un-P1-C6-T1) recorded in [PFW1542-550-7](#).
  4. Reconnect the power cables to the I/O subsystems that were attached to the base system's RIO ports mentioned in [step 2](#) and [step 3](#) of PFW1542-550-23. All I/O subsystems that were

- attached to RIO port 0 on the RIO expansion card (Un-P1-C6-T2) and RIO port 1 on the RIO expansion card (Un-P1-C6-T1) in the base system should now be reconnected to the system.
5. Make sure that the I/O subsystem(s) are cabled correctly as shown in [Connect your unit with HSL/RIO cables](#).
  6. Turn on the power to boot the standalone AIX diagnostic CD-ROM.
  7. If the Please define the System Console screen is displayed, follow the directions to select the system console.
  8. Use the Display Configuration and Resource List option to list all adapters and attached devices.
  9. Verify that all adapters and attached devices are listed.

**Did the Please define the System Console screen display and are all adapters and attached devices listed?**

NO

Go to [PFW1542-550-24](#) to isolate the problems in the I/O subsystems that are attached to the RIO expansion card in the base system.

YES

Go to [PFW1542-550-25](#).

• [PFW1542-550-24](#)

At the base system, reconnect the second I/O subsystem to the RIO ports on the base system's expansion card at Un-P1-C6-T1 and Un-P1-C6-T2.

The 50/94 and the 11D/20 I/O subsystem may both be connected to the ESCALA PL 450T/R. The 11D/20 I/O subsystem is a full-width rack-mounted drawer; the 50/94 can be either a tower or a full-width drawer. The RIO ports on these subsystems, and the RIO ports on the base system that will be used in this section of the procedure, are:

|            | ESCALA PL 450T/R (RIO expansion card) | 50/94                            | 11D/20                          |
|------------|---------------------------------------|----------------------------------|---------------------------------|
| RIO port 0 | Un-P1-C6-T2                           | Un-CB1-C08-00 (bottom connector) | Un-P1-C05-00 (bottom connector) |
| RIO port 1 | Un-P1-C6-T1                           | Un-CB1-C08-01 (top connector)    | Un-P1-C05-01 (top connector)    |

**Note:** Note: Before continuing, check the cabling from the base system to the I/O subsystem(s) to insure that the system is cabled correctly. Refer to [Connect your unit with HSL/RIO cables](#) for valid configurations. Record the current cabling configuration and then continue with the following steps.

1. Turn off the power.
2. At the base system, disconnect the cable connection at RIO port 0 (Un-P1-C6-T2).
3. At the other end of the RIO cable referred to in step 2, disconnect the I/O subsystem port connector 0 (Un-CB1-C08-00 (bottom connector) or Un-P1-C05-00 (bottom connector), depending on the I/O subsystem). The RIO cable that was connected to RIO port 0 on the expansion card should now be loose; remove it. Record the location of this I/O subsystem and call it "subsystem #1".
4. Examine the connection at the I/O port connector 1 (Un-CB1-C08-01 (top connector) or Un-P1-C05-01 (top connector)) of the I/O subsystem recorded in [step 3](#) of [PFW1542-550-24](#). If the RIO cable attached to I/O port connector 1 connects to the I/O port connector 0 of another I/O subsystem, record the location of the next I/O subsystem that is connected to I/O port 1 of subsystem #1, then go to [step 9](#) of [PFW1542-550-24](#).
5. This step is reserved.
6. At the base system, disconnect the cable connection at RIO port 1 on the RIO expansion card (Un-P1-C6-T1) and reconnect it to RIO port 0 on the RIO expansion card (Un-P1-C6-T2).
7. At the I/O subsystem recorded in [step 3](#) of [PFW1542-550-24](#), disconnect the I/O port connector 1 (Un-CB1-C08-01 (top connector) or Un-P1-C05-01 (top connector)) and reconnect to I/O port 0 (Un-CB1-C08-00 (bottom connector) or Un-CB1-C08-00 (bottom connector)).
8. Verify that a single RIO cable connects base system RIO port 0 on the RIO expansion card (Un-P1-C6-T1) to the I/O subsystem recorded in [step 4](#) of [PFW1542-550-24](#) port 0



(Un-CB1-C08-00 (bottom connector) or Un-P1-C05-00 (bottom connector)). Go to [step 21](#) of PFW1542-550-24.

9. Record the location of the next I/O subsystem and call it "subsystem #2". This is the I/O subsystem that is connected to I/O port 1 of subsystem #1.
10. Examine the connection at the I/O port 1 (Un-CB1-C08-01 (top connector) or Un-P1-C05-01 (top connector)) of subsystem #2 recorded in [step 9](#) of PFW1542-550-24. If the RIO cable attached to I/O port 1 connects to the I/O port 0 of another I/O subsystem, record the location of the next I/O subsystem that is connected to I/O port 1 of subsystem #2 and call it "subsystem #3". Go to [step 14](#) of PFW1542-550-24.
11. The RIO cable attached to the I/O port 1 (Un-CB1-C08-01 (top connector) or Un-P1-C05-01 (top connector)) of subsystem #2 is attached to port 1 (Un-P1-C6-T1) of the base system. At the base system, disconnect the cable connection at RIO port 1 on the RIO expansion card (Un-P1-C6-T1) and reconnect it to RIO port 0 on the RIO expansion card (Un-P1-C6-T1).
12. On subsystem #2, disconnect the cable from I/O port 1 (Un-CB1-C08-01 (top connector) or Un-P1-C05-01 (top connector)) and reconnect it to I/O port 0 (Un-CB1-C08-00 (bottom connector) or Un-P1-C05-00 (bottom connector)) of subsystem #1.
13. Verify that a single RIO cable connect base system RIO port 0 to one or two I/O subsystems. Go to [step 21](#) of PFW1542-550-24.
14. Examine the connection at the I/O port 1 (Un-CB1-C08-01 (top connector) or Un-P1-C05-01 (top connector)) of subsystem #3 recorded in [step 10](#) of PFW1542-550-24. If the RIO cable attached to I/O port 1 connects to the I/O port 0 of another I/O subsystem, record the location of the next I/O subsystem that is connected to I/O port 1 of the subsystem #3 and call it "subsystem #4". Go to [step 18](#) of PFW1542-550-24.
15. The RIO cable attached to the I/O port 1 (Un-CB1-C08-01 (top connector) or Un-P1-C05-01 (top connector)) of subsystem #3 is attached to RIO port 1 on the RIO expansion card (Un-P1-C6-T1). At the base system, disconnect the cable connection at RIO port 1 on the RIO expansion card (Un-P1-C6-T1) and reconnect it to RIO port 0 on the RIO expansion card (Un-P1-C6-T1).
16. On subsystem #3, disconnect the cable from I/O port 1 (Un-CB1-C08-01 (top connector) or Un-P1-C05-01 (top connector)) and reconnect it to I/O port 0 (Un-CB1-C08-00 (bottom connector) or Un-P1-C05-00 (bottom connector)) of subsystem #1.
17. Verify that a single RIO cable connects base system RIO port 0 to three I/O subsystems. Go to [step 21](#) of PFW1542-550-24.
18. The RIO cable attached to the I/O port 1 (Un-CB1-C08-01 (top connector) or Un-P1-C05-01 (top connector)) of subsystem #4 is attached to port 1 (Un-P1-C6-T1) on the RIO expansion card. On the RIO expansion card, disconnect the cable connection at RIO port 1 (Un-P1-C6-T1) and reconnect it to RIO port 0 (Un-P1-C6-T2).
19. On subsystem #4, disconnect the cable from I/O port 1 (Un-CB1-C08-01 (top connector) or Un-P1-C05-01 (top connector)) and reconnect it to I/O port 0 (Un-CB1-C08-00 (bottom connector) or Un-P1-C05-00 (bottom connector)) of subsystem #1.
20. Verify that a single RIO cable connects base system RIO port 0 to four I/O subsystems. Continue to [step 21](#) of PFW1542-550-24.
21. Turn on the power to boot the standalone AIX diagnostics from CD-ROM.
22. If the Please define the System Console screen is displayed, follow the directions to select the system console.
23. Use the Display Configuration and Resource List option to list all of the attached devices and adapters.
24. Verify that all adapters and the attached devices are listed.

**Did the Please define the System Console screen display and are all adapters and attached devices listed?**

NO

Go to [PFW1542-550-9](#) to further isolate a problem in the I/O subsystem(s) attached to the RIO expansion card (Un-P1-C6).

YES

The RIO cable that was removed in [step 3](#) of PFW1542-550-24 is defective. Replace this RIO cable.

**Notes:**

1. If four I/O subsystems are chained to RIO port 0 (Un-P1-C6-T1) of the base system, connect the new RIO cable from subsystem #4 I/O port 1 (Un-CB1-C08-01 (top connector) or Un-P1-C05-01 (top connector)) to RIO port 1 on the RIO expansion card (Un-P1-C6-T1).
2. If three I/O subsystems are chained to RIO port 0 (Un-P1-C6-T1) of the base system, connect the new RIO cable from subsystem #3 I/O port 1 (Un-CB1-C08-01 (top connector) or Un-P1-C05-01 (top connector)) to RIO port 1 on the RIO expansion card (Un-P1-C6-T1).

3. If two I/O subsystems are chained to RIO port 0 (Un-P1-C6-T1) of the base system, connect the new RIO cable from subsystem #2 I/O port 1 (Un-CB1-C08-01 (top connector) or Un-P1-C05-01 (top connector)) to RIO port 1 on the RIO expansion card (Un-P1-C6-T1).
4. If one I/O subsystem is chained to RIO port 0 (Un-P1-C6-T1) of the base system, connect the new RIO cable from subsystem #1 I/O port 1 (Un-CB1-C08-01 (top connector) or Un-P1-C05-01 (top connector)) to RIO port 1 on the RIO expansion card (Un-P1-C6-T1).
5. Restore the system back to its original configuration. Go to [MAP 0410: Repair Checkout](#).

• PFW1542-550-25

**Are there any adapters in slots 1, 2, 3, 4, 5, or 6 in the base system?**

NO

Go to [PFW1542-550-26](#).

YES

Go to [PFW1542-550-28](#).

• PFW1542-550-26

Replace the system backplane, Un-P1. Continue to [PFW1542-550-27](#).

• PFW1542-550-27

1. Boot standalone AIX diagnostics from CD.
2. If the Please define the System Console screen is displayed, follow directions to select the system console.
3. Use the Display Configuration and Resource List to list all adapters and attached devices.
4. Check that all adapters and attached devices are listed.

**Did the Please define the System Console screen display and are all attached devices and adapters listed?**

NO

Go to [PFW1542-550-31](#).

YES

Go to [PFW1542-550-20](#).

• PFW1542-550-28

1. If it is not already off, turn off the power.
2. Label and record the location of any cables attached to the adapters.
3. Record the slot number of the adapters.
4. Remove all adapters from slots 1, 2, 3, 4, 5, and 6 in the base system that are not attached to the boot device.
5. Turn on the power to boot standalone AIX diagnostics from CD-ROM.
6. If the ASCII terminal displays Enter 0 to select this console, press the 0 key on the ASCII terminal's keyboard
7. If the Please define the System Console screen is displayed, follow directions to select the system console.
8. Use the Display Configuration and Resource List option to list all adapters and attached devices.
9. Check that all adapters and attached devices are listed.

Did the Please define the System Console screen display and are all attached devices and adapters listed?

NO

Go to [PFW1542-550-26](#).

YES

Continue to [PFW1542-550-29](#).

• PFW1542-550-29

If the Please define the System Console screen does display and all adapters and attached devices are listed, the problem is with one of the adapter cards or devices that was removed or disconnected from the base system.

1. Turn off the power.
2. Reinstall one adapter and device that was removed. Use the original adapter cards in their original slots when reinstalling adapters.
3. Turn on the power to boot standalone AIX diagnostics from CD-ROM.
4. If the Please define the System Console screen is displayed, follow the directions to select the system console.
5. Use the Display Configuration and Resource List to list all adapters and attached devices.
6. Check that all adapters and attached devices are listed.

**Did the Please define the System Console screen display and are all attached devices and adapters listed?**

NO

Continue to [PFW1542-550-30](#).

YES

Return to the beginning of this step to continue reinstalling adapters and devices.

## • PFW1542-550-30

Replace the adapter you just installed with a new adapter and retry the boot to standalone AIX diagnostics from CD-ROM.

1. If the Please define the System Console screen is displayed, follow directions to select the system console.
2. Use the Display Configuration and Resource List option to list all adapters and attached devices.
3. Check that all adapters and attached devices are listed.

**Did the Please define the System Console screen display and are all attached devices and adapters listed?**

NO

Go to [PFW1542-550-26](#).

YES

The adapter you just replaced was defective. Go to [PFW1542-550-20](#).

## • PFW1542-550-31

1. Turn off the power
2. Disconnect the base system power cables.
3. Replace the following parts, one at a time, in the sequence listed:
  - a. Internal SCSI cable
  - b. Disk drive backplanes, one at a time
  - c. Media backplane
  - d. IDE devices, one at a time
  - e. SCSI devices, one at a time
  - f. Service processor.
4. Reconnect the base system power cables.
5. Turn on the power.
6. Boot standalone AIX diagnostics from CD.
7. If the Please define the System Console screen is displayed, follow directions to select the system console.
8. Use the Display Configuration and Resource List option to list all adapters and attached devices.
9. Check that all adapters and attached devices are listed.

**Did the Please define the System Console screen display and are all adapters and attached devices listed?**

NO

Replace the next part in the list and return to the beginning of this step. Repeat this process until a part causes the Please define the System Console screen to be displayed and all adapters and attached devices to be listed. If you have replaced all the items listed above and the Please define the System Console screen does not display or all adapters and attached devices are not listed, check all external devices and cabling.

YES

Go to [PFW1542-550-20](#).**PFW1542-570: I/O problem isolation procedure for model ESCALA PL 1650R-L+ and ESCALA PL 850R/PL 1650R/R+****Purpose of this procedure**

Use this procedure to locate defective FRUs not found by normal diagnostics when servicing an ESCALA PL 850R/PL 1650R/R+. For this procedure, diagnostics are run on a minimally configured system. If a failure is detected on the minimally configured system, the remaining FRUs are exchanged one at a time until the failing FRU is identified. If a failure is not detected, FRUs are added back until the failure occurs. The failure is

then isolated to the failing FRU.

- PFW1542-570-1
  1. Insure that the diagnostics and the operating system are shut down.
  2. Turn off the power.
  3. Select slow system boot speed on the power on/off system menu under the power/restart control menu on the ASMI.
  4. Turn on the power.
  5. Put the AIX diagnostic CD-ROM into the optical drive.

**Does the optical drive appear to operate correctly?**

NO

Go to [Problems with loading and starting the operating system \(AIX and Linux\)](#)

YES

Continue to [PFW1542-570-2](#).

- PFW1542-570-2
  1. When the keyboard indicator is displayed (the word keyboard), if the system or partition gets that far in the IPL process, press the 5 key on the firmware console.
  2. Enter the appropriate password if you are prompted to do so.

**Is the Please define the System Console screen displayed?**

NO

Continue to [PFW1542-570-3](#).

YES

Go to [PFW1542-570-4](#).

- PFW1542-570-3

The system is unable to boot standalone AIX diagnostics. Check the service processor error log (using the ASMI) and the operator panel for additional error codes resulting from the slow boot that was performed in PFW1542-570-1.

**Did the slow boot generate a different error code or partition firmware hang from the one that originally sent you to PFW1542?**

NO

If you were sent here by an error code, and the error code did not change as the result of a slow boot, you have a processor subsystem problem. Go to [PFW1548: Memory and processor subsystem problem isolation procedure](#). If you were sent here because the system is hanging on a partition firmware checkpoint, and the hang condition did not change as a result of the slow boot, go to [PFW1542-570-5](#).

YES

Restore fast boot on the power on/off system menu from the ASMI. Look up the new error code in the reference code index and perform the listed actions.

- PFW1542-570-4

The system stopped with the please define the system console prompt on the system console. Standalone diagnostics can be booted. Perform the following:

1. Follow the instructions on the screen to select the system console.
2. When the DIAGNOSTIC OPERATING INSTRUCTIONS screen is displayed, press Enter.
3. If the terminal type has not been defined, you must use the Initialize Terminal option on the FUNCTION SELECTION menu to initialize the AIX operating system environment before you can continue with the diagnostics. This is a separate operation from selecting the firmware console.
4. Select Advanced Diagnostic Routines.
5. When the DIAGNOSTIC MODE SELECTION menu displays, select System Verification to run diagnostics on all resources.

**Did running diagnostics produce a different symptom?**

NO

Go to [step 6](#) of [PFW1542-570-4](#).

YES

Go to the [Start-of-Call procedure](#). Use the new symptom.

6. Record any devices missing from the list of all adapters and devices. Continue with this procedure. When you have fixed the problem, use this record to verify that all devices appear when you run system verification.

**Are there any devices missing from the list of all adapters and devices?**

NO

Reinstall all remaining adapters, if any, and reconnect all devices. Return the system to its original configuration. Be sure to select fast boot on the power on/off system menu on the ASMI. Go to [MAP 0410: Repair Checkout](#).

YES

The boot attempts that follow will attempt to isolate any remaining I/O subsystem problems with missing devices. Ignore any codes that may display on the operator panel unless stated otherwise. Continue to [PFW1542-570-5](#).

- PFW1542-570-5

Examine RIO port 0 on the base system at Un-P1-T8.

**Are there any I/O subsystems attached to the base system?**

NO

Go to [PFW1542-570-25](#).

YES

Continue to [PFW1542-570-6](#).

- PFW1542-570-6

There may be devices missing from one of more of the I/O subsystems, or one or more devices in the I/O subsystems may be causing the system or a partition to hang during IPL.

**Attention:** The 50/88 expansion unit, 50/94 expansion unit, 50/95 expansion unit, the 7311 Model D10/D11 I/O subsystem, and the 11D/20 I/O subsystem may be connected to this system.

The RIO ports on these subsystems are shown in the following table. Use this table to determine the physical location codes of the RIO connectors that are mentioned in the remainder of this MAP.

|                  | ESCALA<br>PL<br>850R/PL<br>1650R/R+<br>(base<br>system) | 50/88         | 50/94         | 7311-D10/11                       | 11D/20                                | 50/95         |
|------------------|---------------------------------------------------------|---------------|---------------|-----------------------------------|---------------------------------------|---------------|
| RIO<br>port<br>0 | Un-P1-T8                                                | Un-CB1-C10-00 | Un-CB1-C08-00 | Un-P1-C7-00<br>(top<br>connector) | Un-P1-C05-00<br>(bottom<br>connector) | Un-CB1-C05-00 |
| RIO<br>port<br>1 | Un-P1-T9                                                | Un-CB1-C10-01 | Un-CB1-C08-01 | Un-P1-C7-01                       | Un-P1-C05-01                          | Un-CB1-C05-01 |

**Note:** Before continuing, check the cabling from the base system to the I/O subsystem(s) to insure that the system is cabled correctly. Refer to [Connect your unit with HSL/RIO cables](#) for valid configurations. Record the current cabling configuration and then continue with the following steps.

1. Turn off the power. Record the location and machine type and model number, or feature number, of each I/O drawer or tower. In the following steps, use this information to determine the physical location codes of the RIO connectors that are referred to by their logical names. For example, if I/O subsystem #1 is a 11D/20 drawer, RIO port 0 is Un-P1-C05-00.

**Attention:** On all I/O drawers and towers except the 7311-D10/D11, RIO port 0 is the bottom connector on the RIO adapter card. On the 7311-D10/D11, RIO port 0 is the top connector on the RIO adapter card.

2. At the base system, disconnect the cable connection at RIO port 0 (Un-P1-T8).
3. At the other end of the RIO cable referred to in [step 2](#) of PFW1542-570-6, disconnect the I/O subsystem port connector 0. The RIO cable that was connected to RIO port 0 in the base system should now be loose; remove it. Record the location of this I/O subsystem and call it "subsystem #1".
4. Examine the connection at the I/O port connector 1 of the I/O subsystem recorded in [step 3](#) of PFW1542-570-6. If the RIO cable attached to I/O port connector 1 connects to the I/O port connector 0 of another I/O subsystem, record the location of the next I/O subsystem that is connected to I/O port 1 of subsystem #1, then go to [step 9](#) of PFW1542-570-6.
5. This step is reserved.
6. At the base system, disconnect the cable connection at RIO port 1 (Un-P1-T9) and reconnect it to RIO port 0 (Un-P1-T8).
7. At the I/O subsystem recorded in [step 3](#) of PFW1542-570-6, disconnect the I/O port connector 1 and reconnect to I/O port 0.
8. Verify that a single RIO cable connects base system RIO port 0 (Un-P1-T8) to the I/O subsystem recorded in substep 4 port 0. Go to [step 21](#) of PFW1542-570-6.
9. Record the location of the next I/O subsystem and call it "subsystem #2". This is the I/O subsystem that is connected to I/O port 1 of subsystem #1.
10. Examine the connection at the I/O port 1 of subsystem #2 recorded in [step 9](#) of PFW1542-570-6. If the RIO cable attached to I/O port 1 connects to the I/O port 0 of another I/O subsystem, record the location of the next I/O subsystem that is connected to I/O port 1 of subsystem #2 and call it "subsystem #3". Go to [step 14](#) of PFW1542-570-6.
11. The RIO cable attached to the I/O port 1 of subsystem #2 is attached to port 1 (Un-P1-T9) of the base system. At the base system, disconnect the cable connection at RIO port 1 (Un-P1-T9) and reconnect it to RIO port 0 (Un-P1-T8).
12. On subsystem #2, disconnect the cable from I/O port 1 and reconnect it to I/O port 0 of subsystem #1.
13. Verify that a single RIO cable connects base system RIO port 0 to one or two I/O subsystems. Go to [step 21](#) of PFW1542-570-6.
14. Examine the connection at the I/O port 1 of subsystem #3 recorded in [step 10](#) of PFW1542-570-6. If the RIO cable attached to I/O port 1 connects to the I/O port 0 of another I/O subsystem, record the location of the next I/O subsystem that is connected to I/O port 1 of the subsystem #3 and call it "subsystem #4". Go to [step 18](#) of PFW1542-570-6.
15. The RIO cable attached to the I/O port 1 of subsystem #3 is attached to port 1 (Un-P1-T9) of the base system. At the base system, disconnect the cable connection at RIO port 1 (Un-P1-T9) and reconnect it to RIO port 0 (Un-P1-T8).
16. On subsystem #3, disconnect the cable from I/O port 1 and reconnect it to I/O port 0 of subsystem #1.
17. Verify that a single RIO cable connects base system RIO port 0 to three I/O subsystems. Go to [step 21](#) of PFW1542-570-6.
18. The RIO cable attached to the I/O port 1 of subsystem #4 is attached to port 1 (Un-P1-T9) of the base system. At the base system, disconnect the cable connection at RIO port 1 (Un-P1-T9) and reconnect it to RIO port 0 (Un-P1-T8).
19. On subsystem #4, disconnect the cable from I/O port 1 and reconnect it to I/O port 0 of subsystem #1.
20. Verify that a single RIO cable connects base system RIO port 0 to four I/O subsystems. Continue to [step 21](#) of PFW1542-570-6.
21. Turn on the power to boot the standalone AIX diagnostics from CD-ROM.
22. If the Please define the system console screen is displayed, follow the directions to select the system console.
23. Use the Display Configuration and Resource List option to list all of the attached devices and adapters.
24. Verify that all adapters and the attached devices are listed.

**Did the Please define the system console screen display and are all adapters and attached devices listed?**

NO

Go to [PFW1542-570-7](#).

YES

The RIO cable that was removed in [step 3](#) above is defective. Replace this RIO cable.

- ◆ If four I/O subsystems are chained to RIO port 0 (Un-P1-T8) of the base system, connect the new RIO cable from subsystem #4 I/O port 1 to base system RIO port 1 (Un-P1-T9).

- ◆ If three I/O subsystems are chained to RIO port 0 (Un-P1-T8) of the base system, connect the new RIO cable from subsystem #3 I/O port 1 to base system RIO port 1 (Un-P1-T9).
- ◆ If two I/O subsystems are chained to RIO port 0 (Un-P1-T8) of the base system, connect the new RIO cable from subsystem #2 I/O port 1 to base system RIO port 1 (Un-P1-T9).
- ◆ If one I/O subsystem is chained to RIO port 0 (Un-P1-T8) of the base system, connect the new RIO cable from subsystem #1 I/O port 1 to base system RIO port 1 (Un-P1-T9).

Restore the system back to its original configuration. Go to [MAP 0410: Repair Checkout](#).

• PFW1542-570-7

The I/O attached to the RIO ports on the base system planar will now be isolated. Power down the system. Disconnect the cable connection at RIO port 0 (Un-P1-T8) of the base system.

• PFW1542-570-8

1. Turn on the power to boot the standalone diagnostic CD-ROM.
2. If the Please define the system console screen is displayed, follow the directions to select the system console.
3. Use the Display Configuration and Resource List option to list all of the attached devices and adapters.
4. Check that all adapters and attached devices in the base system are listed.

If the Please define the system console screen was not displayed or all adapters and attached devices are not listed, the problem is in the base system.

**Was the Please define the system console screen displayed and were all adapters and attached devices listed?**

NO

Go to [PFW1542-570-25](#).

YES

Go to [PFW1542-570-21](#).

• PFW1542-570-9

For subsystem #1:

- ◆ Are there any adapters in slots 1, 2, 3, 5, 6, or 7 if it is a 7311-D10?
- ◆ Are there any adapters in slots 1, 2, 3, 4, 5, 6, 7, 8, 9, 11, 12, 13, 14, or 15 if it is a 50/88 or 50/94?

NO

Go to [PFW1542-570-10](#).

YES

Go to [PFW1542-570-13](#).

• PFW1542-570-10

For subsystem #2:

- ◆ Are there any adapters in slots 1, 2, 3, 5, 6, or 7 if it is a 7311-D10?
- ◆ **Are there any adapters in slots 1, 2, 3, 4, 5, or 6 if it is a 11D/20?**
- ◆ Are there any adapters in slots 1, 2, 3, 4, 5, 6, 7, 8, 9, 11, 12, 13, 14, or 15 if it is a 50/88 or 50/94?

NO

Go to [PFW1542-570-11](#).

YES

Go to [PFW1542-570-14](#).

• PFW1542-570-11

For subsystem #3:

- ◆ Are there any adapters in slots 1, 2, 3, 5, 6, or 7 if it is a 7311-D10?
- ◆ **Are there any adapters in slots 1, 2, 3, 4, 5, or 6 if it is a 11D/20?**
- ◆ Are there any adapters in slots 1, 2, 3, 4, 5, 6, 7, 8, 9, 11, 12, 13, 14, or 15 if it is a 50/88 or 50/94?

NO

Go to [PFW1542-570-12](#).

YES

Go to [PFW1542-570-15](#).

• PFW1542-570-12

For subsystem #4:

- ◆ Are there any adapters in slots 1, 2, 3, 5, 6, or 7 if it is a 7311-D10?
- ◆ **Are there any adapters in slots 1, 2, 3, 4, 5, or 6 if it is a 11D/20?**
- ◆ Are there any adapters in slots 1, 2, 3, 4, 5, 6, 7, 8, 9, 11, 12, 13, 14, or 15 if it is a 50/88 or 50/94?

NO

Go to [PFW1542-570-19](#).

YES

Go to [PFW1542-570-16](#).

• PFW1542-570-13

1. If it is not already off, turn off the power.
2. Label and record the locations of any cables attached to the adapters, then disconnect the cables.
3. Record the slot numbers of the adapters.
4. Remove all adapters from slots 1, 2, 3, 5, 6, and 7 in the I/O subsystem if it is a 7311-D10, 1, 2, 3, 4, 6, and 7 in the I/O subsystem if it is a 11D/20, or from slot 1-9 and 11-15 if it is a 50/88 or 50/94.
5. Turn on the power to boot the standalone diagnostic CD-ROM.
6. If the ASCII terminal displays Enter 0 to select this console, press the 0 (zero) key on the ASCII terminal's keyboard.
7. If the Please select the system console screen is displayed, follow the directions to select the system console.
8. Use the Display Configuration and Resource List option to list all adapters and attached devices.
9. Check that all adapters and attached devices are listed.

**Was the Please define the system console screen displayed and were all adapters and attached devices listed?**

NO

Go to [PFW1542-570-10](#).

YES

Go to [PFW1542-570-17](#).

• PFW1542-570-14

1. If it is not already off, turn off the power.
2. Label and record the locations of any cables attached to the adapters, then disconnect the cables.
3. Record the slot numbers of the adapters.
4. Remove all adapters from slots 1, 2, 3, 5, 6, and 7 in the I/O subsystem if it is a 7311-D10, slots 1, 2, 3, 4, 6, and 7 in the I/O subsystem if it is a 11D/20, or from slot 1-9 and 11-15 if it is a 50/88 or 50/94.
5. Turn on the power to boot the standalone diagnostic CD-ROM.
6. If the ASCII terminal displays Enter 0 to select this console, press the 0 (zero) key on the ASCII terminal's keyboard.
7. If the Please select the system console screen is displayed, follow the directions to select the system console.
8. Use the Display Configuration and Resource List option to list all adapters and attached devices.
9. Check that all adapters and attached devices are listed.

**Was the Please define the system console screen displayed and were all adapters and attached devices listed?**

NO

Go to [PFW1542-570-11](#).

YES

Go to [PFW1542-570-17](#).

• PFW1542-570-15

1. If it is not already off, turn off the power.
2. Label and record the locations of any cables attached to the adapters, then disconnect the cables.
3. Record the slot numbers of the adapters.
4. Remove all adapters from slots 1, 2, 3, 5, 6, and 7 in the I/O subsystem if it is a 7311-D10, slots 1, 2, 3, 4, 6, and 7 in the I/O subsystem if it is a 11D/20, or from slot 1-9 and 11-15 if it is a 50/88 or 50/94.
5. Turn on the power to boot the standalone diagnostic CD-ROM.
6. If the ASCII terminal displays Enter 0 to select this console, press the 0 (zero) key on the ASCII terminal's keyboard.
7. If the Please select the system console screen is displayed, follow the directions to select the system console.



8. Use the Display Configuration and Resource List option to list all adapters and attached devices.
9. Check that all adapters and attached devices are listed.

**Was the Please define the system console screen displayed and were all adapters and attached devices listed?**

NO

Go to [PFW1542-570-12](#).

YES

Go to [PFW1542-570-17](#).

• PFW1542-570-16

1. If it is not already off, turn off the power.
2. Label and record the locations of any cables attached to the adapters, then disconnect the cables.
3. Record the slot numbers of the adapters.
4. Remove all adapters from slots 1, 2, 3, 5, 6, and 7 in the I/O subsystem if it is a 7311-D10, slots 1, 2, 3, 4, 6, and 7 in the I/O subsystem if it is a 11D/20, or from slots 1-9 and 11-15 if it is a 50/88 or 50/94.
5. Turn on the power to boot the standalone diagnostic CD-ROM.
6. If the ASCII terminal displays Enter 0 to select this console, press the 0 (zero) key on the ASCII terminal's keyboard.
7. If the Please define the system console screen is displayed, follow the directions to select the system console.
8. Use the Display Configuration and Resource List option to list all adapters and attached devices.
9. Check that all adapters and attached devices are listed.

**Was the Please define the system console screen displayed and were all adapters and attached devices listed?**

NO

Go to [PFW1542-570-19](#).

YES

Go to [PFW1542-570-17](#).

• PFW1542-570-17

If the Please define the system console screen was not displayed and all adapters and attached devices were not listed, the problem is with one of the adapter cards or attached devices that was removed or disconnected from the I/O subsystem.

1. Turn off the power.
2. Reinstall one adapter and device that was removed. Use the original adapter cards in their original slots when reinstalling adapters.
3. Turn on the power to boot the standalone diagnostic CD-ROM.
4. If the Please define the system console screen is displayed, follow the directions to select the system console.
5. Use the Display Configuration and Resource List option to list all adapters and attached devices.
6. Check that all adapters and attached devices are listed.

**Was the Please define the system console screen displayed and were all adapters and attached devices listed?**

NO

Go to [PFW1542-570-18](#).

YES

Reinstall the next adapter and device and return to the beginning of this step. Repeat this process until an adapter or device causes the Please define the System Console screen to not display or all attached devices and adapters to not be listed.

After installing all of the adapters and the Please define the System Console screen does display and all attached devices and adapters are listed, return the system to its original configuration. Go to [MAP 0410: Repair Checkout](#).

• PFW1542-570-18

Replace the adapter you just installed with a new adapter and retry booting AIX standalone diagnostics from CD-ROM.

1. If the Please define the system console screen is displayed, follow the directions to select the system console.
2. Use the Display Configuration and Resource List option to list all adapters and attached devices.
3. Check that all adapters and attached devices are listed.

**Was the Please define the system console screen displayed and were all adapters and attached devices listed?**

NO

The I/O subsystem backplane is defective. Replace the I/O subsystem backplane. In all 4 subsystem types, the I/O subsystem backplane is Un-CB1. Then go to [PFW1542-570-20](#).

YES

The adapter was defective. Go to [PFW1542-570-20](#).

• PFW1542-570-19

1. Turn off the power.
2. Disconnect the I/O subsystem power cables.
3. Replace the following parts, one at a time, if present, in the sequence listed:
  - a. I/O subsystem #1 backplane
  - b. I/O subsystem #2 backplane
  - c. I/O subsystem #3 backplane
  - d. I/O subsystem #4 backplane
  - e. The RIO interface in the base system that the RIO cables are presently attached to: either the base planar (Un-P1) if the cables are connected to Un-P1-T8 and Un-P1-T9, or the RIO expansion card (Un-P1-C7) if the RIO cables are attached to Un-P1-C7-T1 and Un-P1-C7-T2.
4. Reconnect the I/O subsystem power cables.
5. Turn on the power.
6. Boot standalone AIX diagnostics from CD.
7. If the Please define the System Console screen is displayed, follow directions to select the system console.
8. Use the Display Configuration and Resource List option to list all adapters and attached devices.
9. Check that all attached devices and adapters are listed.

**Did the Please define the System Console screen display and are all attached devices and adapters listed?**

NO

Replace the next part in the list and return to the beginning of this step. Repeat this process until a part causes the Please define the System Console screen to be displayed and all adapters and attached devices to be listed. If you have replaced all the items listed above and the Please define the System Console screen does not display or all attached devices and adapters are not listed, check all external devices and cabling. If you do not find a problem, contact your next level of support for assistance.

YES

Go to [PFW1542-570-20](#).

• PFW1542-570-20

1. Turn off the power.
2. The item just replaced fixed the problem.
3. If a display adapter with keyboard and mouse were installed, reinstall the display adapter card, keyboard, and mouse.
4. Reconnect the tape drive (if previously installed) to the internal SCSI bus cable.
5. Plug in all adapters that were previously removed but not reinstalled.
6. Reconnect the I/O subsystem power cables that were previously disconnected.

Return the system to its original condition. Go to [MAP 0410: Repair Checkout](#).

• PFW1542-570-21

1. Turn off the power.
2. At the base system, reconnect the cable connection at RIO port 0 (Un-P1-T8) recorded in [PFW1542-570-7](#).
3. At the base system, reconnect the cable connection at RIO port 1 (Un-P1-T9) recorded in [PFW1542-570-7](#).
4. Reconnect the power cables to the I/O subsystems that were found attached to the base system RIO ports mentioned in [step 2](#) and [step 3](#) of PFW1542-570-21. All I/O subsystems that were attached to the base system RIO port 0 and RIO port 1 should now be reconnected to the base system.
5. Make sure the I/O subsystem(s) are cabled correctly as shown in [Connect your unit with HSL/RIO cables](#).
6. Turn on the power to boot standalone AIX diagnostics from CD-ROM.

7. If the Please define the System Console screen is displayed, follow the directions to select the system console.
8. Use the Display Configuration and Resource List option to list all adapters and attached devices.
9. Check that all adapters and attached devices are listed.

**Did the Please define the System Console screen display and are all attached devices and adapters listed?**

NO

Go to [PFW1542-570-9](#) to isolate a problem in an I/O subsystem attached to the base system RIO bus on the system backplane.

YES

Go to [PFW1542-570-22](#).

- PFW1542-570-22

**Is there a RIO expansion card plugged into Un-P1-C7 in the base system, and if so, is there at least one I/O subsystem attached to it?**

NO

Go to [PFW1542-570-25](#).

YES

Continue to [PFW1542-570-23](#).

- PFW1542-570-23
  1. Turn off the power.
  2. At the base system, reconnect the cable connection at RIO port 0 on the RIO expansion card (Un-P1-C7-T2) recorded in [PFW1542-570-7](#).
  3. At the base system, reconnect the cable connection at RIO port 1 on the RIO expansion card (Un-P1-C7-T1) recorded in [PFW1542-570-7](#).
  4. Reconnect the power cables to the I/O subsystems that were attached to the base system's RIO ports mentioned in substeps 2 and 3 in this step. All I/O subsystems that were attached to RIO port 0 on the RIO expansion card (Un-P1-C7-T2) and RIO port 1 on the RIO expansion card (Un-P1-C7-T1) in the base system should now be reconnected to the system.
  5. Make sure that the I/O subsystem(s) are cabled correctly as shown in [Connect your unit with HSL/RIO cables](#)
  6. Turn on the power to boot the standalone AIX diagnostic CD-ROM.
  7. If the Please define the system console screen is displayed, follow the directions to select the system console.
  8. Use the Display Configuration and Resource List option to list all adapters and attached devices.
  9. Verify that all adapters and attached devices are listed.

**Did the Please define the system console screen display and are all adapters and attached devices listed?**

NO

Go to [PFW1542-570-24](#) to isolate the problems in the I/O subsystems that are attached to the RIO expansion card in the base system.

YES

Go to [PFW1542-570-25](#).

- PFW1542-570-24

At the base system, reconnect the second I/O subsystem to the RIO ports on the base system's expansion card at Un-P1-C7-T1 and Un-P1-C7-T2.

**Attention:** The 50/88 expansion unit, 50/94 expansion unit, 50/95 expansion unit, the 7311 Model D10/D11 I/O subsystem, and the 11D/20 I/O subsystem may be connected to this system.

The RIO ports on these subsystems are shown in the following table. Use this table to determine the physical location codes of the RIO connectors that are mentioned in the remainder of this MAP.

|  |                                  |              |              |                    |               |              |
|--|----------------------------------|--------------|--------------|--------------------|---------------|--------------|
|  | <b>ESCALA<br/>PL<br/>850R/PL</b> | <b>50/88</b> | <b>50/94</b> | <b>7311-D10/11</b> | <b>11D/20</b> | <b>50/95</b> |
|--|----------------------------------|--------------|--------------|--------------------|---------------|--------------|

## Service provider information

|            | 1650R/R+<br>(base system) |               |               |                                |                                    |               |
|------------|---------------------------|---------------|---------------|--------------------------------|------------------------------------|---------------|
| RIO port 0 | Un-P1-T8                  | Un-CB1-C10-00 | Un-CB1-C08-00 | Un-P1-C7-00<br>(top connector) | Un-P1-C05-00<br>(bottom connector) | Un-CB1-C05-00 |
| RIO port 1 | Un-P1-T9                  | Un-CB1-C10-01 | Un-CB1-C08-01 | Un-P1-C7-01                    | Un-P1-C05-01                       | Un-CB1-C05-01 |

**Note:** Before continuing, check the cabling from the base system to the I/O subsystem(s) to insure that the system is cabled correctly. Refer to [Connect your unit with HSL/RIO cables](#) for valid configurations. Record the current cabling configuration and then continue with the following steps.

1. Turn off the power.
2. Record the location and machine type and model number, or feature number, of each I/O drawer or tower. In the following steps, use this information to determine the physical location codes of the RIO connectors that are referred to by their logical names. For example, if I/O subsystem #1 is a 11D/20 drawer, RIO port 0 is Un-P1-C05-00.
3. At the base system, disconnect the cable connection at RIO port 0 (Un-P1-C7-T2).
4. At the other end of the RIO cable referred to in [step 2](#) of PFW1542-570-24, disconnect the I/O subsystem port connector 0. The RIO cable that was connected to RIO port 0 on the expansion card should now be loose; remove it. Record the location of this I/O subsystem and call it "subsystem #1".
5. Examine the connection at the I/O port connector 1 of the I/O subsystem recorded in [step 3](#) of PFW1542-570-24. If the RIO cable attached to I/O port connector 1 connects to the I/O port connector 0 of another I/O subsystem, record the location of the next I/O subsystem that is connected to I/O port 1 of subsystem #1, then go to [step 9](#) of PFW1542-570-24.
6. This step is reserved.
7. At the base system, disconnect the cable connection at RIO port 1 on the RIO expansion card (Un-P1-C7-T1) and reconnect it to RIO port 0 on the RIO expansion card (Un-P1-C7-T2).
8. At the I/O subsystem recorded in [step 3](#) of PFW1542-570-24, disconnect the I/O port connector 1 and reconnect to I/O port 0.
9. Verify that a single RIO cable connects base system RIO port 0 on the RIO expansion card (Un-P1-C7-T1) to the I/O subsystem recorded in [step 4](#) of PFW1542-570-24 port 0. Go to [step 21](#) of PFW1542-570-24.
10. Record the location of the next I/O subsystem and call it "subsystem #2". This is the I/O subsystem that is connected to I/O port 1 of subsystem #1.
11. Examine the connection at the I/O port 1 of subsystem #2 recorded in [step 9](#) of PFW1542-570-24. If the RIO cable attached to I/O port 1 connects to the I/O port 0 of another I/O subsystem, record the location of the next I/O subsystem that is connected to I/O port 1 of subsystem #2 and call it "subsystem #3". Go to [step 14](#) of PFW1542-570-24.
12. The RIO cable attached to the I/O port 1 of subsystem #2 is attached to port 1 (Un-P1-C7-T1) of the base system. At the base system, disconnect the cable connection at RIO port 1 on the RIO expansion card (Un-P1-C7-T1) and reconnect it to RIO port 0 on the RIO expansion card (Un-P1-C7-T1).
13. On subsystem #2, disconnect the cable from I/O port 1 and reconnect it to I/O port 0 of subsystem #1.
14. Verify that a single RIO cable connect base system RIO port 0 to one or two I/O subsystems. Go to [step 21](#) of PFW1542-570-24.
15. Examine the connection at the I/O port 1 of subsystem #3 recorded in [10](#) of PFW1542-570-24. If the RIO cable attached to I/O port 1 connects to the I/O port 0 of another I/O subsystem, record the location of the next I/O subsystem that is connected to I/O port 1 of the subsystem #3 and call it "subsystem #4". Go to [step 18](#) of PFW1542-570-24.
16. The RIO cable attached to the I/O port 1 of subsystem #3 is attached to RIO port 1 on the RIO expansion card (Un-P1-C7-T1). At the base system, disconnect the cable connection at RIO port 1 on the RIO expansion card (Un-P1-C7-T1) and reconnect it to RIO port 0 on the RIO expansion card (Un-P1-C7-T1).
17. On subsystem #3, disconnect the cable from I/O port 1 and reconnect it to I/O port 0 of subsystem #1.

18. Verify that a single RIO cable connects base system RIO port 0 to three I/O subsystems. Go to [step 21](#) of PFW1542-570-24.
19. The RIO cable attached to the I/O port 1 of subsystem #4 is attached to port 1 (Un-P1-C7-T1) on the RIO expansion card. On the RIO expansion card, disconnect the cable connection at RIO port 1 (Un-P1-C7-T1) and reconnect it to RIO port 0 (Un-P1-C7-T2).
20. On subsystem #4, disconnect the cable from I/O port 1 and reconnect it to I/O port 0 of subsystem #1.
21. Verify that a single RIO cable connects base system RIO port 0 to four I/O subsystems. Continue to [step 22](#) of PFW1542-570-24.
22. Turn on the power to boot the standalone AIX diagnostics from CD-ROM.
23. If the Please define the system console screen is displayed, follow the directions to select the system console.
24. Use the Display Configuration and Resource List option to list all of the attached devices and adapters.
25. Verify that all adapters and the attached devices are listed.

**Did the Please define the system console screen display and are all adapters and attached devices listed?**

NO

Go to [PFW1542-570-9](#) to further isolate a problem in the I/O subsystem(s) attached to the RIO expansion card (Un-P1-C7).

YES

The RIO cable that was removed in [step 3](#) of PFW1542-570-24 is defective. Replace this RIO cable.

- ◆ If four I/O subsystems are chained to RIO port 0 (Un-P1-C7-T1) of the base system, connect the new RIO cable from subsystem #4 I/O port 1 to RIO port 1 on the RIO expansion card (Un-P1-C7-T1).
- ◆ If three I/O subsystems are chained to RIO port 0 (Un-P1-C7-T1) of the base system, connect the new RIO cable from subsystem #3 I/O port 1 to RIO port 1 on the RIO expansion card (Un-P1-C7-T1).
- ◆ If two I/O subsystems are chained to RIO port 0 (Un-P1-C7-T1) of the base system, connect the new RIO cable from subsystem #2 I/O port 1 to RIO port 1 on the RIO expansion card (Un-P1-C7-T1).
- ◆ If one I/O subsystem is chained to RIO port 0 (Un-P1-C7-T1) of the base system, connect the new RIO cable from subsystem #1 I/O port 1 to RIO port 1 on the RIO expansion card (Un-P1-C7-T1).

Restore the system back to its original configuration. Go to [MAP 0410: Repair Checkout](#).

- PFW1542-570-25

Are there any adapters in slots 1, 2, 3, 4, 5, or 6 in the base system?

NO

Go to [PFW1542-570-26](#).

YES

Go to [PFW1542-570-28](#).

- PFW1542-570-26

Replace the system backplane, Un-P1. Continue to [PFW1542-570-27](#).

- PFW1542-570-27
  1. Boot standalone AIX diagnostics from CD.
  2. If the Please define the System Console screen is displayed, follow directions to select the system console.
  3. Use the Display Configuration and Resource List to list all adapters and attached devices.
  4. Check that all adapters and attached devices are listed.

**Did the Please define the System Console screen display and are all attached devices and adapters listed?**

NO

Go to [PFW1542-570-31](#).

YES

Go to [PFW1542-570-20](#).

- PFW1542-570-28
  1. If it is not already off, turn off the power.
  2. Label and record the location of any cables attached to the adapters.
  3. Record the slot number of the adapters.
  4. Remove all adapters from slots 1, 2, 3, 4, 5, and 6 in the base system that are not attached to the boot device.

5. Turn on the power to boot standalone AIX diagnostics from CD-ROM.
6. If the ASCII terminal displays Enter 0 to select this console, press the 0 key on the ASCII terminal's keyboard.
7. If the Please define the System Console screen is displayed, follow directions to select the system console.
8. Use the Display Configuration and Resource List option to list all adapters and attached devices.
9. Check that all adapters and attached devices are listed.

**Did the Please define the System Console screen display and are all attached devices and adapters listed?**

NO

Go to [PFW1542-570-26](#).

YES

Continue to [PFW1542-570-29](#).

• PFW1542-570-29

If the Please define the System Console screen does display and all adapters and attached devices are listed, the problem is with one of the adapter cards or devices that was removed or disconnected from the base system.

1. Turn off the power.
2. Reinstall one adapter and device that was removed. Use the original adapter cards in their original slots when reinstalling adapters.
3. Turn on the power to boot standalone AIX diagnostics from CD-ROM.
4. If the Please define the System Console screen is displayed, follow the directions to select the system console.
5. Use the Display Configuration and Resource List to list all adapters and attached devices.
6. Check that all adapters and attached devices are listed.

**Did the Please define the System Console screen display and are all attached devices and adapters listed?**

NO

Continue to [PFW1542-570-30](#).

YES

Return to the beginning of this step to continue reinstalling adapters and devices.

• PFW1542-570-30

Replace the adapter you just installed with a new adapter and retry the boot to standalone AIX diagnostics from CD-ROM.

1. If the Please define the System Console screen is displayed, follow directions to select the system console.
2. Use the Display Configuration and Resource List option to list all adapters and attached devices.
3. Check that all adapters and attached devices are listed.

**Did the Please define the System Console screen display and are all attached devices and adapters listed?**

NO

Go to [PFW1542-570-26](#).

YES

The adapter you just replaced was defective. Go to [PFW1542-570-20](#).

• PFW1542-570-31

1. Turn off the power.
2. Disconnect the base system power cables.
3. Replace the following parts, one at a time, in the sequence listed:
  - a. Internal SCSI cable
  - b. Disk drive backplanes, one at a time
  - c. Media backplane
  - d. IDE devices, one at a time
  - e. SCSI devices, one at a time
  - f. Service processor
4. Reconnect the base system power cables.
5. Turn on the power.
6. Boot standalone AIX diagnostics from CD.

7. If the Please define the System Console screen is displayed, follow directions to select the system console.
8. Use the Display Configuration and Resource List option to list all adapters and attached devices.
9. Check that all adapters and attached devices are listed.

**Did the Please define the System Console screen display and are all adapters and attached devices listed?**

NO

Replace the next part in the list and return to the beginning of this step. Repeat this process until a part causes the Please define the System Console screen to be displayed and all adapters and attached devices to be listed. If you have replaced all the items listed above and the Please define the System Console screen does not display or all adapters and attached devices are not listed, check all external devices and cabling. If you do not find a problem, contact your next level of support for assistance.

YES

Go to [PFW1542-570-20](#).

## PFW1542-575: I/O problem isolation procedure for model 5/75

This MAP is used to locate defective FRUs not found by normal diagnostics.

### Purpose of this MAP

For this procedure, diagnostics are run on a minimally configured system. If a failure is detected on the minimally configured system, the remaining FRUs are exchanged one at a time until the failing FRU is identified. If a failure is not detected, FRUs are added back until the failure occurs. The failure is then isolated to the failing FRU. This I/O problem-determination MAP isolates I/O card and I/O subsystem failures. When I/O problem isolation is complete, all cables and cards exhibiting a failure will have been replaced or reseated.

### Notes:

1. This MAP requires that a NIM server be accessible to provide the ability to boot to standalone diagnostics. Alternately, the service representative may choose to use online diagnostics available from a bootable hard drive already attached to the system. Using online diagnostics reduces coverage (especially for boot device problems) and magnifies problems with missing resources during I/O isolation. The preferred method is to run the standalone diagnostics from a NIM server.
2. If a general-access password or privileged-access password is installed, you are prompted to enter the password before the diagnostics can load.
3. The term POST indicators refers to the device mnemonics (words memory, keyboard, network, scsi, and speaker) that appear on the system console during the power-on self-test (POST).
4. The service processor may have recorded one or more symptoms in its error log. It is a good idea to examine that error log before proceeding and take actions as indicated.
5. The service processor may have been set by the user to monitor system operations and to attempt recoveries. You can disable these actions while you diagnose and service the system. If you disable them, make notes of their current settings so that you can restore them easily.
6. The service processor might have been set by the user to monitor system operations and to attempt recoveries. You might want to disable these options while you diagnose and service the system. If these settings are disabled, make notes of their current settings so that they can be restored before the system is turned back over to the customer. The following settings may be of interest.

Monitoring (also called surveillance)

From the ASMI menu, expand the System Configuration menu, then click on Monitoring.

Disable both types of surveillance.

Auto power restart (also called unattended start mode)

From the ASMI menu, expand Power/Restart Control, then click on Auto Power Restart, and set it to disabled.

Wake on LAN

From the ASMI menu, expand Wake on LAN, and set it to disabled.

Call Out

From the ASMI menu, expand the Service Aids menu, then click on Call-Home/Call-In Setup. Set the call-home system port and the call-in system port to disabled.

7. If this is a ESCALA PL Series system, verify that the system has not been set to boot to the SMS menus or to the open firmware prompt. From the ASMI menu, expand Power/Restart Control to view the menu, then click on Power On/Off System. The AIX/Linux partition mode boot should say "Continue to Operating System".

The steps in this procedure will attempt to slow boot the system into service mode diagnostics. The procedure for booting a partitioned system with an attached HMC is described in [Performing a Slow Boot](#). Performing slow boot describes the procedure for booting online diagnostics (6 key between the keyboard and speaker indicators) and the following procedure requires booting standalone diagnostics (5 key between the keyboard and speaker indicators). Therefore, on a partitioned system, ensure the partition you selected to boot in the following procedure has an Ethernet interface allocated to it, as described in [Loading and Using the AIX online diagnostics or the standalone diagnostics](#).

- PFW1542-575-1
  1. Ensure that the diagnostics and the operating system are shut down.

**Note:** When you are directed to turn power off or turn power on in this procedure, follow the instructions in [Powering the System On and Off](#).

2. Turn off the power.
  3. Select slow-boot mode. See [Performing a Slow Boot](#).
  4. Turn on the power.
- PFW1542-575-2
    1. When the keyboard indicator is displayed (the word keyboard), press the 5 key on the firmware console.
    2. Enter the appropriate password when you are prompted to do so.

**Is the Please Define the System Console screen displayed?**

No

Go to [PFW1542-575-3](#).

Yes

Go to [PFW1542-575-4](#).

- PFW1542-575-3

The system is unable to boot standalone diagnostics. Check the service processor error log for additional error codes resulting from the slow boot done in [PFW1542-575-1](#).

**Did the slow boot generate a different error code from the one that originally sent you to MAP 1542?**

No

It appears you have a processor subsystem problem. Call for service support. This ends the procedure.

Yes

Follow the actions for the new error code.

- PFW1542-575-4

The system stopped with the Please Define the System Console prompt appearing on the system console. Standalone diagnostics can be booted. Perform the following:

1. Follow the instructions on the screen to select the system console.
2. When the DIAGNOSTIC OPERATING INSTRUCTIONS screen is displayed, press Enter.
3. If the terminal type has not been defined, you must use the Initialize Terminal option on the Function Selection Menu to initialize the AIX operating system environment before you can continue with the diagnostics.

This is a separate operation from selecting the firmware console display.

4. Select Advanced Diagnostic Routines.
5. When the Diagnostic Mode Selection Menu displays, select system verification to run diagnostics on all resources.

**Did running diagnostics produce a different symptom?**



No

Go to substep [PFW1542-575-6](#).

Yes

Go to the [Start-of-Call](#). Use the new symptom.

- Record any devices missing from the list of all adapters and devices.

Continue with this MAP. When you have fixed the problem, use this record to verify that all devices appear when you run system verification.

**Are there any devices missing from the list of all adapters and devices?**

No

Reinstall all remaining adapters, if any, and reconnect all devices. Return the system to its original configuration. Be sure to select fast-boot mode using either the HMC or the AMSI menus. Go to [MAP 0410: Repair Checkout](#).

Yes

The boot attempts that follow will attempt to isolate any remaining I/O subsystem problems with missing devices. Ignore any codes that may display on the operator panel value on the HMC unless stated otherwise. Go to [PFW1542-575-5](#).

- PFW1542-575-5

**Examine the processor subsystem RIO port A0 (Un-P1-T7). Are there any I/O subsystems attached to this processor subsystem?**

No

Go to [PFW1542-575-22](#).

Yes

Go to [PFW1542-575-6](#).

- PFW1542-575-6

There might be missing devices associated with one or more I/O subsystems.

Before continuing, check the cabling from the processor subsystem to I/O subsystem(s) to ensure that the system is cabled correctly. Record the current cabling configuration and then continue with the following steps:

**Notes:**

- Turn off the power.
- At the processor subsystem, disconnect the cable connection at RIO port A0 (Un-P1-T7). Follow this RIO cable to a RIO connector on an I/O subsystem at the other end.
- If the RIO cable in substep [pfw154257562](#) is connected to the right side of the I/O subsystem, disconnect the right I/O port connector 0 (Un-P2-T2). The RIO cable that was connected to RIO port A0 on the processor subsystem should now be loose and can be removed. Record the location of this I/O subsystem and that it is not looped right. Go to substep [pfw154257565](#).
- If the RIO cable in substep [pfw154257562](#) above is connected to the left side of the I/O subsystem, disconnect the left I/O port connector 0 (Un-P1-T2). The RIO cable that was connected to RIO port A0 on the processor subsystem should now be loose and can be removed. Record the location of this I/O subsystem. Go to substep [pfw154257568](#).
- At the processor subsystem, disconnect the cable connection at RIO port A1 (Un-P1-T8) and reconnect it to RIO port A0 (Un-P1-T7).
- At the I/O subsystem recorded in substep [pfw154257563](#), disconnect the right I/O port connector 1 (Un-P2-T1) and reconnect to the right I/O port connector 0 (Un-P2-T2).
- Verify that a single RIO cable connects processor subsystem RIO port A0 (Un-P1-Q1) to the right I/O port connector 0 (Un-P2-T2) of the I/O subsystem. Go to substep [pfw1542575614](#).
- Examine the connection at the left I/O port connector 1 of the I/O subsystem recorded in substep [pfw154257564](#). If the RIO cable attached to the left I/O port connector 1 of the I/O subsystem leads to the right I/O port connector 0 of the I/O subsystem, record that the I/O subsystem is looped. Go to substep [pfw1542575613](#).
- If the RIO cable attached to the left I/O port connector 1 of the I/O subsystem leads to port A1 of the processor subsystem, record that the I/O subsystem is not looped left.
- At the processor subsystem, disconnect the cable connection at RIO port A1 (Un-P1-T8) and reconnect it to RIO port A0 (Un-P1-T7).
- At the I/O subsystem recorded in substep [pfw154257564](#), disconnect the left I/O port connector 1 (Un-P1-T1) and reconnect to the left I/O port connector 0 (Un-P1-T2).

12. Verify that a single RIO cable connects processor subsystem RIO port A0 (Un-P1-Q1) to the left I/O port connector 0 of the I/O subsystem. Go to substep [pfw1542575614](#).
13. At the I/O subsystem recorded in substep [pfw154257564](#), disconnect the right I/O port connector 1 (Un-P2-T1) and reconnect to the left I/O port connector 0 (Un-P1-T2). Go to substep [pfw1542575612](#)
14. If the I/O subsystem was looped, verify that the I/O subsystem left I/O port connector 1 (Un-P1-T1) is connected to the I/O subsystem right I/O port connector 0 (Un-P2-T2).
15. Turn on the power to boot standalone diagnostics from the NIM server.
16. If the Please Define the System Console screen is displayed, follow the directions to select the system console.
17. Use the Display Configuration and Resource List to list all attached devices and adapters.
18. Check that all attached devices and adapters are listed.

**Did the Please Define the System Console screen display and are all attached devices and adapters listed?**

No

Go to [PFW1542-575-7](#).

Yes

The RIO cable that was removed in substep [PFW1542-57563](#) or [PFW1542-57564](#) above is defective. Replace the RIO cable. If the I/O subsystem was looped, connect the new RIO cable from I/O subsystem 1 right I/O port connector 1 (Un-P2-T1) to processor subsystem RIO port A1 (Un-P1-T8). If the I/O subsystem was not looped left, connect the new RIO cable from the I/O subsystem left I/O port connector 1 (Un-P1-T1) to processor subsystem RIO port A1 (Un-P1-T8). If the I/O subsystem was not looped right, connect the new RIO cable from the I/O subsystem right I/O port connector 1 (Un-P2-T1) to processor subsystem RIO port A1 (Un-P1-T8). Reconfigure the system to its original condition. Go to [MAP 0410: Repair Checkout](#).

• [PFW1542-575-7](#)

The system may have only one full-width I/O subsystem attached to a processor subsystem. The following steps reduce the system I/O to the minimum required:

1. Turn off the system power.
2. At the processor subsystem, disconnect the cable connection at RIO port A0 (Un-P1-T7).
3. At the processor subsystem, disconnect the cable connection at RIO port A1 (Un-P1-T8).
4. Disconnect the power cables from the I/O subsystem(s) that were attached to the processor subsystem. All I/O subsystems should now be physically disconnected from the processor subsystem. Go to [PFW1542-575-8](#).

• [PFW1542-575-8](#)

The processor subsystem is running from the integrated I/O or from I/O attached to an adapter installed into one of the integrated PCI slots.

1. Turn on the power to boot standalone diagnostics from the NIM server.
2. If the Please Define the System Console prompt is displayed, follow the directions to select the system console.
3. Use the Display Configuration and Resource List to list all attached devices and adapters.
4. Check that all attached devices and adapters are listed.

If the "Please Define the System Console" prompt did not display or all attached devices and adapters are not listed, the problem is in processor subsystem.

**Did the Please Define the System Console screen display and are all attached devices and adapters listed?**

No

Go to [PFW1542-575-22](#).

Yes

Go to [PFW1542-575-21](#).

• [PFW1542-575-9](#)

**If the I/O subsystem is looped, or not looped left (see step [PFW1542-575-6](#)), are there any adapters in slot 1, 2, 3, 4 or 5 (location codes Un-P1-C1 through C5) on the left side of the I/O subsystem?**

No

Go to [PFW1542-575-10](#).

Yes

Go to [PFW1542-575-13](#).

- PFW1542-575-10

**If the I/O subsystem is looped, or not looped left, (see step [PFW1542-575-6](#)), are there any adapters in slot 6, 7, 8, 9 or 10 (location codes Un-P1-C6 through C10) on the left side of the I/O subsystem?**

No

Go to [PFW1542-575-11](#).

Yes

Go to [PFW1542-575-14](#).

- PFW1542-575-11

**If the I/O subsystem is looped or not looped right, (see step [PFW1542-575-6](#)), are there any adapters in slots 1, 2, 3, 4 or 5 (location codes Un-P2-C1 through C5) on the right side of the I/O subsystem?**

No

Go to [PFW1542-575-12](#).

Yes

Go to [PFW1542-575-15](#).

- PFW1542-575-12

**If the I/O subsystem is looped or not looped right, (see step [PFW1542-575-6](#)), are there any adapters in slots 6, 7, 8, 9 or 10 (location codes Un-P2-C6 through C10) on the right side of the I/O subsystem?**

No

Go to [PFW1542-575-19](#).

Yes

Go to [PFW1542-575-16](#).

- PFW1542-575-13

**Did the Please Define the System Console screen display and are all attached devices and adapters listed?**

No

Go to [PFW1542-575-10](#).

Yes

Go to [PFW1542-575-17](#).

- PFW1542-575-14

1. If it is not already off, turn off the power.
2. Remove all adapters from slots 1, 2, 3, 4 and 5 (location codes Un-P1-C1 through C5) from the left side of the I/O subsystem.
3. Label and record the location of any cables attached to the adapters.
4. Record the slot number of the adapters.
5. Turn on the power to boot standalone diagnostics from the NIM server.
6. If the TTY screen displays "Enter 0 to select this console", press the 0 key on the TTY terminal's keyboard.
7. If the Please Define the System Console screen is displayed, follow the directions to select the system console.
8. Use the Display Configuration and Resource List to list all adapters and attached devices.
9. Check that all attached devices and adapters are listed.

**Did the Please Define the System Console screen display and are all attached devices and adapters listed?**

No

Go to [PFW1542-575-11](#).

Yes

Go to [PFW1542-575-17](#).

- PFW1542-575-15

1. If it is not already off, turn off the power.
2. Remove all adapters from slots 1, 2, 3, 4 and 5 (location codes Un-P2-C1 through C5) from the right side of the I/O subsystem.
3. Label and record the location of any cables attached to the adapters.

4. Record the slot number of the adapters.
5. Turn on the power to boot standalone diagnostics from the NIM server.
6. If the TTY screen displays "Enter 0 to select this console", press the 0 key on the TTY terminal's keyboard.
7. If the Please Define the System Console screen is displayed, follow the directions to select the system console.
8. Use the Display Configuration and Resource List to list all attached devices and adapters.
9. Check that all attached devices and adapters are listed.

**Did the Please Define the System Console screen display and are all attached devices and adapters listed?**

No

Go to [PFW1542-575-12](#).

Yes

Go to [PFW1542-575-17](#).

• PFW1542-575-16

1. If it is not already off, turn off the power.
2. Remove all adapters from slots 6, 7, 8, 9 and 10 (location codes Un-P2-C6 through C10) from the right side of the I/O subsystem.
3. Label and record the location of any cables attached to the adapters.
4. Record the slot number of the adapters.
5. Turn on the power to boot standalone diagnostics from the NIM server.
6. If the TTY screen displays "Enter 0 to select this console", press the 0 key on the TTY terminal's keyboard.
7. If the Please Define the System Console screen is displayed, follow the directions to select the system console.
8. Use the Display Configuration and Resource List to list all attached devices and adapters.
9. Check that all attached devices and adapters are listed.

**Did the Please Define the System Console screen display and are all attached devices and adapters listed?**

No

Go to [PFW1542-575-19](#).

Yes

Go to [PFW1542-575-17](#).

• PFW1542-575-17

If the Please Define the System Console screen does display and all attached devices and adapters are listed, the problem is with one of the adapter cards or devices that was removed or disconnected from the I/O subsystem.

1. Turn off the power.
2. Reinstall one adapter or device that was removed.
3. Turn on the power to boot standalone diagnostics from the NIM server.
4. If the Please Define the System Console screen is displayed, follow the directions to select the system console.
5. Use the Display Configuration and Resource List to list all attached devices and adapters.
6. Check that all attached devices and adapters are listed.

**Did the Please Define the System Console screen display and are all attached devices and adapters listed?**

No

Go to [PFW1542-575-18](#).

Yes

Reinstall the next adapter or device and return to the beginning of this step. Continue repeating this process until an adapter or device causes the "Please Define the System Console" screen to not display or all attached devices and adapters to not be listed. After installing all of the adapters and the "Please Define the System Console" screen does display and all attached devices and adapters are listed, return the system to its original configuration. Go to [MAP 0410: Repair Checkout](#).

• PFW1542-575-18

Replace the adapter you just installed with a new adapter and retry the boot to standalone diagnostics from the NIM server.

1. If the Please Define the System Console screen is displayed, follow the directions to select the system console.

2. Use the Display Configuration and Resource List to list all attached devices and adapters.
3. Check that all attached devices and adapters are listed.

**Did the Please Define the System Console screen display and are all attached devices and adapters listed?**

No

The I/O subsystem backplane is defective. Replace the I/O subsystem backplane on the side of the problem adapter (Un-P1 or Un-P2). Go to [PFW1542-575-20](#).

Yes

The adapter was defective. Go to [PFW1542-575-20](#).

- PFW1542-575-19
  1. Turn off the power.
  2. Disconnect the I/O subsystem power cables.
  3. Replace the following parts, one at a time, in the sequence listed:
    - a. I/O subsystem backplane at Un-P1.
    - b. I/O subsystem backplane at Un-P2.
    - c. I/O subsystem DCA at Un-E1.
    - d. I/O subsystem DCA at Un-E2.
  4. Reconnect the I/O subsystem power cables.
  5. Turn on the power.
  6. Boot standalone diagnostics from the NIM server.
  7. If the "Please Define the System Console" screen is displayed, follow the directions to select the system console.
  8. Use the "Display Configuration and Resource List" to list all attached devices and adapters.
  9. Check that all attached devices and adapters are listed.
- PFW1542-575-20
  1. Turn off the power.
  2. The item just replaced fixed the problem.
  3. Plug in all adapters that were previously removed but not reinstalled.
  4. Reconnect the I/O subsystem power cables that were previously disconnected.

Reconfigure the system to its original condition. Go to [MAP 0410: Repair Checkout](#).
- PFW1542-575-21
  1. Turn off the power.
  2. At the processor subsystem, reconnect the cable connection at RIO port A0 (Un-P1-T7).
  3. At the processor subsystem, reconnect the cable connection at RIO port A1 (Un-P1-T8).
  4. Reconnect the power cables from the I/O subsystem(s) that were attached to the processor subsystem.

All I/O subsystems should now be physically reconnected to the processor subsystem.

  5. Ensure that the I/O subsystem is cabled correctly.
  6. Go to [PFW1542-575-9](#).
- PFW1542-575-22

**Are there any adapters in slots 1, 2, 3, or 4 (location codes Un-P1-C1, Un-P1-C2, Un-P1-C4, or Un-P1-C5) in the processor subsystem?**

No

Go to [PFW1542-575-23](#).

Yes

Go to [PFW1542-575-25](#).

- PFW1542-575-23

**Attention:** Contact service support before replacing the I/O backplane.

1. Turn off the power.
2. Disconnect the processor subsystem power cables.
3. Replace the following parts, one at a time, in the sequence listed:
  - a. Internal SCSI hard drives, if present, at Un-P1-D1 and Un-P1-D2.
  - b. I/O backplane, Un-P1.
4. Reconnect the processor subsystem power cables.
5. Turn on the power.
6. Boot standalone diagnostics from the NIM server.

7. If the Please Define the System Console screen is displayed, follow the directions to select the system console.
8. Use the Display Configuration and Resource List to list all attached devices and adapters.
9. Check that all attached devices and adapters are listed.

**Did the Please define the System Console screen display and are all attached devices and adapters listed?**

No

Replace the next part in the list and return to the beginning of this step. Continue repeating this process until a part causes the Please Define the System Console screen to be displayed and all attached devices and adapters to be listed. If you have replaced all the items listed above and the Please Define the System Console screen does not display or all attached devices and adapters are not listed, check any external devices and cabling. If you do not find a problem, contact your next level of support for assistance.

Yes

Go to [PFW1542-575-24](#).

• PFW1542-575-24

1. Turn off the power.
2. The item just replaced fixed the problem.
3. Plug in all adapters that were previously removed but not reinstalled.
4. Reconnect the I/O subsystem power cables that were previously disconnected.

Reconfigure the system to its original condition. Go to [MAP 0410: Repair Checkout](#).

• PFW1542-575-25

1. Power down the system if necessary.
2. Remove the PCI adapter(s), if present, in slots Un-P1-C1, Un-P1-C2, Un-P1-C4, and Un-P1-C5.
3. Power on the system to boot standalone diagnostics from the NIM server.

**Did the Please Define the System Console screen does display and all attached devices and adapters left in the processor subsystem show up using the Display Configuration and Resource List option?**

No

Go to [PFW1542-575-23](#).

Yes

Go to [PFW1542-575-26](#).

• PFW1542-575-26

The problem is with one of the adapter cards or devices that was removed or disconnected from the processor subsystem.

Turn off the power.

**Have all of the PCI adapters been reinstalled?**

No

Reinstall one adapter or device that was removed. Use the original adapter cards in their original slots when reinstalling adapters. Go to [PFW1542-575-27](#).

Yes

Go to [PFW1542-575-23](#).

• PFW1542-575-27

Power on the system to boot standalone diagnostics from the NIM server.

**Did the Please Define the System Console screen does display and all attached devices and adapters left in the processor subsystem show up using the Display Configuration and Resource List option?**

No

Go to [PFW1542-575-28](#).

Yes

Go to [PFW1542-575-26](#).

• PFW1542-575-28

Replace the adapter you just installed with a new adapter and retry the boot to standalone diagnostics from the NIM server.

1. If the Please Define the System Console screen is displayed, follow the directions to select the system console.
2. Use the Display Configuration and Resource List to list all attached devices and adapters.
3. Check that all attached devices and adapters are listed.

**Did the Please define the System Console screen display and are all attached devices and adapters listed?**

No

The processor subsystem I/O unit's backplane is defective. Replace the I/O backplane (Un-P1). Go to [PFW1542-575-20](#).

Yes

The adapter was defective. Go to [PFW1542-575-20](#).

## **PFW1542-590: I/O problem isolation procedure for model ESCALA PL 3250R, and 5/95**

Use this procedure to locate defective FRUs not found by normal diagnostics.

### **Purpose of this MAP**

This MAP is used to locate defective FRUs not found by normal diagnostics. For this procedure, diagnostics are run on a minimally configured system. If a failure is detected on the minimally configured system, the remaining FRUs are exchanged one at a time until the failing FRU is identified. If a failure is not detected, FRUs are added back until the failure occurs. The failure is then isolated to the failing FRU.

This I/O problem-determination procedure isolates I/O card and I/O subsystem failures. When I/O problem isolation is complete, all cables and cards exhibiting a failure will have been reseated or replaced.

### **Notes:**

1. This procedure assumes that an optical drive is installed in the integrated media drawer and connected to the SCSI LVD adapter, and that an AIX diagnostic CD-ROM is available.
2. If a power-on password or privileged-access password is set, you are prompted to enter the password before the AIX diagnostic CD-ROM can load.
3. The term POST indicators refers to the device mnemonics that appear during the power-on self-test (POST).
4. The service processor might have recorded one or more symptoms in its error/event log. Use the ASMI menus to view the error/event log.
  - ◆ If you arrived here after performing a slow boot, look for a possible new error that occurred during the slow boot. If there is a new error, and its actions call for a FRU replacement, perform those actions. If this does not resolve the problem, go to [PFW1542-590-1](#).
  - ◆ If an additional slow boot has not been performed, or if the slow boot did not yield a new error code, look at the error that occurred just before the original error. Perform the actions associated with that error. If the problem is not resolved, go to [PFW1542-590-1](#).
  - ◆ If a slow boot results in the same error code, and there are no error codes before the original error code, go to [PFW1542-590-1](#).
5. The service processor might have been set by the user to monitor system operations and to attempt recoveries. You might want to disable these options while you diagnose and service the system. If these settings are disabled, make notes of their current settings so that they can be restored before the system is turned back over to the customer. The following settings may be of interest. Monitoring (also called surveillance) From the ASMI menu, expand the System Configuration menu, then click on Monitoring. Disable both types of surveillance. Auto power restart (also called unattended start mode) From the ASMI menu, expand Power/Restart Control, then click on Auto Power Restart, and set it to disabled. Wake on LAN From the ASMI menu, expand Wake on LAN, and set it to disabled. Call Out From the ASMI menu, expand the Service Aids menu, then click on Call-Home/Call-In Setup. Set the call-home system port and the call-in system port to disabled.
6. If this is a ESCALA PL Series system, verify that the system has not been set to boot to the SMS menus or to the open firmware prompt. From the ASMI menu, expand Power/Restart Control to view the menu, then click on Power On/Off System. The AIX/Linux partition mode boot should say

"Continue to Operating System".

- PFW1542-590-1
  1. Insure that the diagnostics and the operating system are shut down
  2. Use the HMC to power down the system.
  3. Access the ASMI menus, Power/Restart Control, Power On/Off System, set the System boot speed to slow.
  4. Turn on the power to the system using the HMC.
  5. Does the optical drive appear to boot the AIX diagnostic CD-ROM?

**Does the optical drive appear to boot the AIX diagnostic CD-ROM?**

NO

Go to [Problems With Booting and Loading the Operating System](#). After the problem has been corrected, return to [PFW1542-590-1](#).

YES

Go to [PFW1542-590-2](#).

- PFW1542-590-2
  1. After the word keyboard is displayed on the firmware console, but before the word speaker is displayed, press the number 5 key.
  2. If you are prompted to do so, enter the appropriate password.

**Is the Please define the System Console screen displayed?**

NO

Go to [PFW1542-590-3](#).

YES

Go to [PFW1542-590-4](#).

- PFW1542-590-3

The system is unable to boot standalone diagnostics.

Check the service processor error log and the control panel for additional error codes resulting from the slow boot in step PFW1542-590-1.

**Did the slow boot generate a different error code from the one that originally sent you to PFW1542-590?**

NO

It appears there is a problem in the processor subsystem. Call for support. This ends the procedure.

YES

Go to the [Start-of-call](#) procedure with the new error code.

- PFW1542-590-4

The system stopped with the Please define the system console prompt appearing on the system console.

Standalone diagnostics can be booted. Perform the following:

1. Follow the instructions on the screen to select the diagnostic console.
2. When the DIAGNOSTIC OPERATING INSTRUCTIONS screen is displayed, press Enter.
3. If the terminal type has not been defined, you must use the Initialize Terminal option of the FUNCTION SELECTION menu to initialize the AIX operating system environment before you can continue with the diagnostics. This is a separate operation from selecting the firmware console display.
4. Select Advanced Diagnostic Routines.
5. When the DIAGNOSTIC MODE SELECTION menu displays, select System Verification to run diagnostics on all resources.

**Did running diagnostics produce a different symptom?**

NO

Go to substep [PFW1542-590-4-6](#).

YES

Go to the [start-of-call](#) procedure with the new symptom.



6. Record any devices missing from the list of all adapters and devices. Continue with this procedure. When you have fixed the problem, use this record to verify that all devices appear when you run system verification.

**Are there any devices missing from the list of all adapters and devices?**

NO

Reinstall all remaining adapters, if any, and reconnect all devices. Return the system to its original configuration. Be sure to select fast-boot mode on the Power/Restart Control menu on the ASMI. Go to [MAP 0410: Repair Checkout](#). This ends the procedure.

YES

The boot attempts that follow will attempt to isolate any remaining I/O subsystem problems with missing devices. Ignore any codes that may display on the control panel unless stated otherwise. Continue to [PFW1542-590-5](#).

- PFW1542-590-5

There are missing devices associated with one or more I/O subsystems.

**Note:** Before continuing, check the cabling from the processor subsystem to the I/O subsystem(s) to insure that the system is cabled correctly. Refer to the following adapter plugging rules tables for valid configurations. Record the current cabling configuration and then continue with the following steps:

The ESCALA PL 3250R server must have a minimum of one I/O subsystem and one media subsystem attached to the processor subsystem. The following substeps reduce the system I/O to the minimum of one I/O subsystem.

1. Use the HMC to turn off the power to the managed system.
2. The RIO adapters should be populated, and cabled, according to one of the following tables:

**Note:** The tables are model dependent.

Table 1. Model ESCALA PL 3250R GX+ adapter plugging rules

| 16W System     |           | 32W System     |           |
|----------------|-----------|----------------|-----------|
| Node 0 Slot D1 | Un-P2-C1  | Node 0 Slot D1 | Un-P2-C1  |
| Node 0 Slot D2 | Un-P2-C3  | Node 1 Slot D2 | Un-P3-C3  |
| Node 0 Slot D8 | Un-P2-C13 | Node 0 Slot D8 | Un-P2-C13 |
| Node 0 Slot D7 | Un-P2-C11 | Node 1 Slot D8 | Un-P3-C13 |
| Node 0 Slot D6 | Un-P2-C9  | Node 0 Slot D7 | Un-P2-C11 |
| Node 0 Slot D5 | Un-P2-C8  | Node 1 Slot D7 | Un-P3-C11 |
| Node 0 Slot D4 | Un-P2-C6  | Node 0 Slot D6 | Un-P2-C9  |
| Node 0 Slot D3 | Un-P2-C5  | Node 1 Slot D6 | Un-P3-C9  |
|                |           | Node 0 Slot D5 | Un-P2-C8  |
|                |           | Node 1 Slot D5 | Un-P3-C8  |
|                |           | Node 0 Slot D4 | Un-P2-C6  |
|                |           | Node 1 Slot D4 | Un-P3-C6  |
|                |           | Node 0 Slot D3 | Un-P2-C5  |
|                |           | Node 1 Slot D3 | Un-P3-C5  |
|                |           | Node 0 Slot D2 | Un-P2-C3  |

Service provider information

|  |  |                |          |
|--|--|----------------|----------|
|  |  | Node 1 Slot D1 | Un-P3-C1 |
|--|--|----------------|----------|

Table 2. Model ESCALA PL 6450R GX+ adapter plugging rules

| 16W System                 | 32W System                 | 48W System                 | 64W System                 |
|----------------------------|----------------------------|----------------------------|----------------------------|
| Node 0 Slot D1<br>Un-P2-C1 | Node 0 Slot<br>D1Un-P2-C1  | Node 0 Slot<br>D1Un-P2-C1  | Node 0 Slot<br>D1Un-P2-C1  |
| Node 0 Slot<br>D2Un-P2-C3  | Node 1 Slot<br>D2Un-P2-C3  | Node 1 Slot<br>D2Un-P3-C3  | Node 1 Slot<br>D2Un-P3-C3  |
| Node 0 Slot<br>D8Un-P2-C13 | Node 0 Slot<br>D8Un-P2-C13 | Node 2 Slot<br>D8Un-P4-C13 | Node 2 Slot<br>D8Un-P4-C13 |
| Node 0 Slot<br>D7Un-P2-C11 | Node 1 Slot<br>D8Un-P3-C13 | Node 0 Slot<br>D8Un-P2-C13 | Node 3 Slot<br>D8Un-P5-C13 |
| Node 0 Slot<br>D6Un-P2-C9  | Node 0 Slot<br>D7Un-P2-C11 | Node 1 Slot<br>D8Un-P3-C13 | Node 0 Slot<br>D8Un-P2-C13 |
| Node 0 Slot<br>D5Un-P2-C8  | Node 1 Slot<br>D7Un-P3-C11 | Node 2 Slot<br>D7Un-P4-C11 | Node 1 Slot<br>D8Un-P3-C13 |
|                            | Node 0 Slot<br>D6Un-P2-C9  | Node 0 Slot<br>D7Un-P2-C11 | Node 2 Slot<br>D7Un-P4-C11 |
|                            | Node 1 Slot<br>D6Un-P3-C9  | Node 1 Slot<br>D7Un-P3-C11 | Node 3 Slot<br>D7Un-P5-C11 |
|                            | Node 0 Slot<br>D5Un-P2-C8  | Node 2 Slot<br>D6Un-P4-C9  | Node 0 Slot<br>D7Un-P2-C11 |
|                            | Node 1 Slot<br>D5Un-P3-C8  | Node 0 Slot<br>D6Un-P2-C9  | Node 1 Slot<br>D7Un-P3-C11 |
|                            | Node 0 Slot<br>D2Un-P2-C3  | Node 1 Slot<br>D6Un-P3-C9  | Node 2 Slot<br>D6Un-P4-C9  |
|                            | Node 1 Slot<br>D2Un-P3-C3  | Node 2 Slot<br>D5Un-P4-C8  | Node 3 Slot<br>D6Un-P5-C9  |
|                            |                            | Node 0 Slot<br>D5Un-P2-C8  | Node 0 Slot<br>D6Un-P2-C9  |
|                            |                            | Node 1 Slot<br>D5Un-P3-C8  | Node 1 Slot<br>D6Un-P3-C9  |
|                            |                            | Node 2 Slot<br>D2Un-P4-C3  | Node 2 Slot<br>D5Un-P4-C8  |
|                            |                            | Node 0 Slot<br>D2Un-P2-C3  | Node 3 Slot<br>D5Un-P5-C8  |
|                            |                            | Node 1 Slot<br>D1Un-P3-C1  | Node 0 Slot<br>D5Un-P2-C8  |
|                            |                            | Node 2 Slot<br>D1Un-P4-C1  | Node 1 Slot<br>D5Un-P3-C8  |
|                            |                            |                            | Node 2 Slot<br>D2Un-P4-C3  |
|                            |                            |                            | Node 3 Slot<br>D2Un-P4-C3  |
|                            |                            |                            | Node 0 Slot<br>D2Un-P2-C3  |
|                            |                            |                            | Node 1 Slot<br>D1Un-P3-C1  |
|                            |                            |                            | Node 2 Slot<br>D1Un-P4-C1  |
|                            |                            |                            | Node 3 Slot<br>D1Un-P5-C1  |

Leave the cables attached to the RIO adapter in the top-most position in the first node ( $U_n$ -P2-C1). Unplug the rest of the RIO adapters in the first node and all additional nodes; carefully pull them out approximately 12 mm (1/2 inch) away from the node connector without disconnecting any cables.

3. Verify that the media subsystem still has a power cable connected. Remove the power cables from all I/O subsystems except the one who's RIO adapter is still plugged into the node.
4. At the first RIO adapter, disconnect the cable connection at RIO port 0 ( $U_n$ -P2-C1-T1).
5. Disconnect the cable connection at I/O subsystem 1's (at  $U_n$ ) left RIO port connector 0 ( $U_n$ -P1-T2). The RIO cable that was connected to RIO port 0 in step 2 should be loose and can now be removed.
6. At the first RIO adapter, disconnect the cable connection at RIO port 1 ( $U_n$ -P1-C1-T2) and reconnect it to RIO port 0 ( $U_n$ -P1-C1-T1).
7. Disconnect the cable connection at I/O subsystem 1's (at  $U_n$ ) right RIO port connector 1 ( $U_n$ -P2-T1) and reconnect it to I/O subsystem 1's (at  $U_n$ ) left RIO port connector 0 ( $U_n$ -P2-T2).
8. Verify that I/O subsystem 1's (at  $U_n$ ) left RIO port connector 1 ( $U_n$ -P1-T1) is connected to I/O subsystem 1's (at  $U_n$ ) right RIO port connector 0 ( $U_n$ -P2-T2).
9. Use the HMC to turn on the power to boot the AIX standalone diagnostics from CD-ROM.
10. Use the Display Configuration and Resource List option to list all adapters and attached devices.
11. Check that all adapters and attached devices are listed.

**Did the Please Define the System Console screen display and are all adapters and attached devices listed?**

NO

Go to [PFW1542-590-7](#).

YES

The RIO cable that was removed in step 5 above is defective. Replace the RIO cable. Connect the new RIO cable from I/O subsystem 1's right port connector 1 ( $U_n$ -P2-T1) to RIO connector 1's (at  $U_n$ -P1-C1-T2) port 1. Return the system to its original configuration. Go to [MAP 0410: Repair Checkout](#).

- PFW1542-590-6

This step is reserved. Go to [PFW1542-590-7](#).

- PFW1542-590-7

The first I/O subsystem (at  $U_n$ ) and the media drawer are the only drawers connected to the processor subsystem.

1. Access the ASMI menus, Power/Restart Control, Power On/Off System, set the system boot speed to slow.
2. Turn on the power to the system using the HMC.
3. After the word keyboard is displayed on the firmware console, but before the word speaker is displayed, press the number 5 key.
4. If you are prompted to do so, enter the appropriate password.
5. As soon as the optical drive has power, insert the AIX diagnostic CD-ROM into the optical drive.
6. If the Please define the System Console screen is displayed, follow directions to select the system console.
7. Use the Display Configuration and Resource List to list all attached devices and adapters
8. Check that all attached devices and adapters are listed. If the Please define the System Console prompt did not display or all attached devices and adapters are not listed, the problem is in the media subsystem or I/O subsystem 1 (at  $U_n$ ).

**Did the Please define the System Console screen display and are all attached devices and adapters listed?**

NO

Go to [PFW1542-590-8](#).

YES

Go to [PFW1542-590-21](#).

- PFW1542-590-8

Perform the following to deconfigure the media subsystem:

1. Use the HMC to turn off power to the managed system.
2. If you have not already done so, set the service processor settings with the instructions just before PFW1542-590-1 in this procedure, then return here and continue.

3. Disconnect the AC power cable going to the media subsystem.
  4. If a graphics adapter with a keyboard and mouse is connected to a USB adapter in the first I/O subsystem, and is being used as the firmware console, locate an ASCII terminal (a 3151, for example) and attach it to the S1 port on the back of the CEC. You can also use a virtual terminal on the HMC as the firmware console.
  5. If present, remove the keyboard and mouse from the USB adapter in the first I/O subsystem.
  6. Unplug all other devices, in any, in the media subsystem except the optical drive.
  7. Reconnect the AC power cable going to the media subsystem. Continue to [PFW1542-590-9](#).
- **PFW1542-590-9**

**Are there any adapters in slots 1, 2, 3, 4 or 5 (location codes Un-P1-C1 through C5) on the left side of the I/O subsystem?**

NO

Go to [PFW1542-590-10](#).

YES

Go to [PFW1542-590-13](#).

- **PFW1542-590-10**

**Are there any adapters in slots 6, 7, 8, 9 or 10 (location codes Un-P1-C6 through C10) on the left side of the I/O subsystem?**

NO

Go to [PFW1542-590-11](#).

YES

Go to [PFW1542-590-12](#).

- **PFW1542-590-11**

**Are there any adapters in slots 1, 2, 3, 4 or 5 (location codes Un-P2-C1 through C5) on the right side of the I/O subsystem?**

NO

Go to [PFW1542-590-12](#).

YES

Go to [PFW1542-590-13](#).

- **PFW1542-590-12**

**Are there any adapters in slots 6, 7, 8, 9 or 10 (location codes Un-P2-C7 through C10) on the right side of the I/O subsystem?**

NO

Go to [PFW1542-590-19](#).

YES

Go to [PFW1542-590-16](#).

- **PFW1542-590-13**

1. If it is not already off, turn off the power.
2. Remove all adapters from slots 1, 2, 3, 4 and 5 (location codes Un-P1-C1 through C5) from the left side of the I/O subsystem that are not attached to the boot device.
3. Label and record the location of any cables attached to the adapters.
4. Record the slot number of the adapters.
5. Turn on the power to boot standalone diagnostics from CD.
6. If the TTY screen displays enter 0 to select this console by pressing the 0 key on the TTY terminal's keyboard.
7. If the Please define the System Console screen is displayed, follow the directions to select the system console.
8. Use the Display Configuration and Resource List to list all attached devices and adapters.
9. Check that all attached devices and adapters are listed.

**Did the Please define the System Console screen display and are all attached devices and adapters listed?**

NO

Go to [PFW1542-590-10](#).

YES

Go to [PFW1542-590-17](#).

- **PFW1542-590-14**

1. If it is not already off, turn off the power.

2. Remove all adapters from slots 6, 7, 8, 9 and 10 (location codes Un-P1-C6 through C10) from the left side of the I/O subsystem that are not attached to the boot device.
3. Label and record the location of any cables attached to the adapters.
4. Record the slot number of the adapters.
5. Turn on the power to boot standalone diagnostics from CD.
6. If the TTY screen displays Enter 0 to select this console, press the 0 key on the TTY terminal's keyboard.
7. If the Please define the System Console screen is displayed, follow directions to select the system console.
8. Use the Display Configuration and Resource List to list all attached devices and adapters.
9. Check that all attached devices and adapters are listed.

**Did the Please define the System Console screen display and are all attached devices and adapters listed?**

NO

Go to [PFW1542-590-11](#).

YES

Go to [PFW1542-590-17](#).

• **PFW1542-590-15**

1. If it is not already off, turn off the power.
2. Remove all adapters from slots 1, 2, 3, 4 and 5 (location codes Un-P2-C1 through C5) from the right side of the I/O subsystem that are not attached to the boot device.
3. Label and record the location of any cables attached to the adapters.
4. Record the slot number of the adapters.
5. Turn on the power to boot standalone diagnostics from CD.
6. If the TTY screen displays Enter 0 to select this console, press the 0 key on the TTY terminal's keyboard.
7. If the Please define the System Console screen is displayed, follow directions to select the system console.
8. Use the Display Configuration and Resource List to list all attached devices and adapters.
9. Check that all attached devices and adapters are listed.

**Did the Please define the System Console screen display and are all attached devices and adapters listed?**

NO

Go to [PFW1542-590-11](#).

YES

Go to [PFW1542-590-16](#).

• **PFW1542-590-16**

1. If it is not already off, turn off the power.
2. Remove all adapters from slots 6, 7, 8, 9 and 10 (location codes Un-P2-C6 through C10) from the right side of the I/O subsystem that are not attached to the boot device.
3. Label and record the location of any cables attached to the adapters.
4. Record the slot number of the adapters.
5. Turn on the power to boot standalone diagnostics from CD.
6. If the TTY screen displays Enter 0 to select this console, press the 0 key on the TTY terminal's keyboard.
7. If the Please define the System Console screen is displayed, follow directions to select the system console.
8. Use the Display Configuration and Resource List to list all attached devices and adapters.
9. Check that all attached devices and adapters are listed.

**Did the Please define the System Console screen display and are all attached devices and adapters listed?**

NO

Go to [PFW1542-590-19](#).

YES

Go to [PFW1542-590-17](#).

• **PFW1542-590-17**

If the Please define the System Console screen displays and all adapters and attached devices are listed, the problem is with one of the adapter cards or devices that was removed or disconnected from the I/O subsystem.

1. Turn off the power.
2. Reinstall one adapter or device that was removed. Use the original adapter cards in their original slots when reinstalling adapters.

3. Turn on the power to boot standalone diagnostics from CD.
4. If the Please define the System Console screen is displayed, follow directions to select the system console.
5. Use the Display Configuration and Resource List to list all attached devices and adapters.
6. Check that all attached devices and adapters are listed.

**Did the Please define the System Console screen display and are all attached devices and adapters listed?**

NO

Go to [PFW1542-590-18](#).

YES

Reinstall the next adapter or device and return to the beginning of this step. Continue repeating this process until an adapter or device causes the Please define the System Console screen to not display or all attached devices and adapters to not be listed. After installing all of the adapters and the Please define the System Console screen does display and all attached devices and adapters are listed, return the system to its original configuration. Go to [MAP 0410: Repair Checkout](#). This ends the procedure.

• **PFW1542-590-18**

Replace the adapter you just installed with a new adapter and try to boot standalone diagnostics from CD again.

1. If the Please define the System Console screen is displayed, follow directions to select the system console.
2. Use the Display Configuration and Resource List to list all attached devices and adapters.
3. Check that all attached devices and adapters are listed.

**Did the Please define the System Console screen display and are all attached devices and adapters listed?**

NO

The I/O subsystem backplane is defective. Replace the I/O subsystem backplane on the side of the problem adapter (*Un-P1* or *Un-P2*). Go to [PFW1542-590-21](#).

YES

The adapter was defective. Go to [PFW1542-590-21](#).

• **PFW1542-590-19**

1. Turn off the power.
2. Disconnect the I/O subsystem power cables.
3. Replace the following parts, one at a time, in the sequence listed:
  - a. Boot device SCSI cable, if applicable.
  - b. Boot device SCSI adapter, if applicable.
  - c. Boot device SCSI backplane, if applicable.
  - d. Boot device, if applicable.
  - e. I/O subsystem backplane where boot device is located, if applicable.
  - f. Other I/O subsystem backplane
  - g. Both I/O subsystem DCAs
4. Reconnect the I/O subsystem power cables.
5. Turn on the power.
6. Boot standalone diagnostics from CD-ROM.
7. If the Please define the System Console screen is displayed, follow directions to select the system console.
8. Use the Display Configuration and Resource List to list all attached devices and adapters.
9. Check that all attached devices and adapters are listed.

**Did the Please define the System Console screen display and are all attached devices and adapters listed?**

NO

Replace the next part in the list and return to the beginning of this step. Continue repeating this process until a part causes the Please define the System Console screen to be displayed and all attached devices and adapters to be listed. If you have replaced all the items listed above and the Please define the System Console screen does not display or all attached devices and adapters are not listed, check any external devices and cabling. If you do not find a problem, contact your next level of support for assistance.

YES

Go to [PFW1542-590-21](#).

• **PFW1542-590-20**

1. Turn off the power.
2. The part just replaced fixed the problem

3. If a display adapter with keyboard, and mouse were used, reinstall the display adapter card, keyboard and mouse.
4. Reconnect the diskette drive cable to the diskette drive connector on the media subsystem.
5. Reconnect the tape drive (if previously installed) to the internal SCSI bus cable.
6. Plug in all adapters that were previously removed but not reinstalled.
7. Reconnect the I/O subsystem power cables that were previously disconnected. Reconfigure the system to its original condition. Go to [MAP 0410: Repair Checkout](#). This ends the procedure.

• **PFW1542-590-21**

If the boot is successful, the problem is with one of the remaining I/O subsystems. Use the HMC to turn off the power.

**Are there any RIO adapters left to connect to the processor subsystem?**

NO

Return the system to its original configuration. Go to [MAP 0410: Repair Checkout](#). This ends the procedure.

YES

Reconnect the next RIO adapter in the sequence shown in [PFW1542-590-5](#) plugging rules tables, then continue to [PFW1542-590-22](#).

• **PFW1542-590-22**

1. At the RIO adapter that was just replugged, disconnect the cable connection at RIO port 0 (Un-Px-Cy-T1).
2. Disconnect the cable connection at the I/O subsystem's left I/O port connector 0 (Un-P1-T2). The RIO cable that was connected to RIO port 0 should now be loose and can be removed.
3. At the RIO adapter that was just replugged, disconnect the cable connection at RIO port 1 (Un-Px-Cy-T2) and reconnect it to port 0 (Un-Px-Cy-T1).
4. Disconnect the cable connection at the I/O subsystem's right I/O port connector 1 (Un-P2-T1) and reconnect it to the I/O subsystem's left I/O port connector 0 (Un-P1-T2).
5. Verify that the I/O subsystem's left I/O port connector 1 (Un-P1-T1) is connected to the I/O subsystem's right I/O port connector 0 (Un-P2-T2).
6. Use the HMC to turn on the power to boot AIX standalone diagnostics from CD.
7. If the Please define the System Console screen is displayed, follow the directions to select the system console.
8. Use the Display Configuration and Resource List to list all attached devices and adapters.
9. Check that all attached devices and adapters are listed.

**Did the Please define the System Console screen display and are all attached devices and adapters listed?**

NO

Connect the previously removed RIO cable from I/O subsystem 2 right I/O port connector 1 (Un-P2/Q1) to processor subsystem RIO port B1 on primary I/O book (Un-P1-H2/Q4). Go to [PFW1542-590-9](#).

YES

The RIO cable that was removed in [PFW1542-590-22-2](#) above is defective. Replace the RIO cable. Connect the new RIO cable from the I/O subsystem's right I/O port connector 1 (Un-P2-T1) to RIO adapter port 1 (Un-Px-Cy-T2). Return the system to its original configuration. Go to [MAP 0410: Repair Checkout](#). This ends the procedure.

## **PFW1543: Model ESCALA PL 3250R and model ESCALA PL 6450R MCM problem isolation procedure**

Use this procedure to locate defective FRUs not found by normal diagnostics.

### **Purpose of this procedure**

This procedure is used to locate defective FRUs not found by normal diagnostics. It should be used when the service processor posts a failure and halts the IPL before server firmware standby is reached.

To perform this procedure, run diagnostics on a minimally configured system. If a failure is detected on the minimally configured system, the remaining FRUs are exchanged one at a time until the failing FRU is identified. If a failure is not detected, FRUs are added back until the failure occurs. The failure is then isolated

to the failing FRU.

This MCM problem-determination procedure isolates processor subsystem failures.

#### Notes:

- The service processor might have recorded one or more symptoms in its error/event log. Use the Advanced System Management Interface (ASMI) menus to view the error/event log.
  - ◆ If you arrived here after performing a slow boot, look for a possible new error that occurred during the slow boot. If there is a new error, and its actions call for a FRU replacement, perform those actions. If this does not resolve the problem, go to [PFW1543-1](#).
  - ◆ If an additional slow boot has not been performed, or if the slow boot did not yield a new error code, look at the error that occurred prior to the original error. Perform the actions associated with that error. If the problem is not resolved, go to [PFW1543-1](#).
  - ◆ If a slow boot results in the same error code, and there are no error codes before the original error code, go to [PFW1543-1](#).
- The service processor might have been set by the user to monitor system operations and to attempt recoveries. You might want to disable these options while you diagnose and service the system. If these settings are disabled, make notes of their current settings so that they can be restored before the system is turned back over to the customer. The following settings may be of interest.

| Setting                                                | Description                                                                                                                                                     |
|--------------------------------------------------------|-----------------------------------------------------------------------------------------------------------------------------------------------------------------|
| Monitoring (also called surveillance)                  | From the ASMI menu, expand the System Configuration menu, then click on Monitoring. Disable both types of surveillance.                                         |
| Auto power restart (also called unattended start mode) | From the ASMI menu, expand Power/Restart Control, then click on Auto Power Restart, and set it to disabled.                                                     |
| Wake on LAN                                            | From the ASMI menu, expand Wake on LAN, and set it to disabled.                                                                                                 |
| Call Out                                               | From the ASMI menu, expand the Service Aids menu, then click on Call-Home/Call-In Setup. Set the call-home system port and the call-in system port to disabled. |

- If this is a ESCALA PL Series system, verify that the system has not been set to boot to the SMS menus or to the open firmware prompt. From the ASMI menu, expand Power/Restart Control to view the menu, then click on Power On/Off System. The AIX/Linux partition mode boot should say "Continue to Operating System".

#### • PFW1543-1

Record the error code(s) and location codes(s) that sent you to this procedure.

#### • PFW1543-2

Use the HMC to power off the system.

Examine the amber logic-power LEDs on all of the processor subsystem DCAs.

#### • PFW1543-3

**Are all of the amber logic-power LEDs on all of the processor subsystem DCAs off?**

NO

Contact service support.

YES



Continue to [step 1543-4](#).

• **PFW1543-4**

**Attention:** Some of the parts in the following lists have a limit of xxx plug cycles.

You may be asked to replace one or more of the following cards and MCM modules. Before replacing any of the listed MCM modules, call for support.

- ◆ MCM module 0 at location Un-Px-??
- ◆ MCM module 0 at location Un-Px-??
- ◆ System clock card(s) at location Un-P1-C3 and Un -P1-C4

Replace, in the order listed, the following modules or cards, if present, one at a time:

1. Clock cards, Un-P1-C3 and Un-P1-C2.
2. First location code, if any, recorded in [PFW1543-1](#).
3. Second location code, if any, recorded in [PFW1543-1](#).
4. Third location code, if any, recorded in [PFW1543-1](#).
5. Fourth location code, if any, recorded in [PFW1543-1](#).
6. Fifth location code, if any, recorded in [PFW1543-1](#).
7. Sixth location code, if any, recorded in [PFW1543-1](#).
8. MCM 0 at Un-Pn-?? if not recorded in [PFW1543-1](#).
9. MCM 1 at Un-Pn-?? if not recorded in [PFW1543-1](#).

• **PFW1543-5**

Turn on the power.

• **PFW1543-6**

**Does the system stop with the same error code as recorded in step 1543-1?**

NO

The module just replace was defective. Return the system to its original configuration. Go to [MAP 0410: Repair Checkout](#). This ends the procedure.

YES

Go to [PFW1543-7](#).

• **PFW1543-7**

**Have all of the modules listed in step 1543-4 been replaced?**

NO

Go to [PFW1543-2](#).

YES

Go to [PFW1543-8](#).

• **PFW1543-8**

Turn off the power.

• **PFW1543-9**

Examine the amber logic-power LEDs on all of the processor subsystem DCAs.

• **PFW1543-10**

**Are all of the amber logic-power LEDs on all of the processor subsystem DCAs off?**

NO

Contact service support.

YES

Continue to [PFW1543-11](#).

• **PFW1543-11**

**Attention:** Before replacing the node's backplane, call service support.

Replace the node's backplane and chassis, Un-Px.

- **PFW1543-12**

Turn on the power.

- **PFW1543-13**

**Does the system stop with the same error code as recorded in step 1543-1?**

NO

The part just replaced was defective. Return the system to its original configuration. Go to [MAP 0410: Repair Checkout](#). This ends the procedure.

YES

Go to [PFW1543-14](#).

- **PFW1543-14**

Turn off the power.

Make sure that all of the amber logic-power LEDs on all of the processor subsystem DCAs are off.

- **PFW1543-15**

Call service support.

**Parent topic:** [Problems with loading and starting the operating system \(AIX and Linux\)](#)

---

## **PFW1546: Model ESCALA PL 3250R and model ESCALA PL 6450R memory problem isolation procedure**

Use this procedure to locate defective FRUs not found by normal diagnostics.

### **Purpose of this procedure**

Use this procedure to locate defective FRUs not found by normal diagnostics. It should be used when the service processor posts a failure and halts the IPL before server firmware standby is reached.

To perform this procedure, run diagnostics on a minimally configured system. If a failure is detected on the minimally configured system, the remaining FRUs are exchanged one at a time until the failing FRU is identified. If a failure is not detected, FRUs are added back until the failure occurs. The failure is then isolated to the failing FRU.

This memory problem-determination procedure isolates memory subsystem failures. When memory problem isolation is complete, memory cards exhibiting a failure will have been reseated or replaced.

### **Notes:**

1. The service processor might have recorded one or more symptoms in its error/event log. Use the Advanced System Management Interface (ASMI) menus to view the error/event log.
  - ◆ If you arrived here after performing a slow boot, look for a possible new error that occurred during the slow boot. If there is a new error, and its actions call for a FRU replacement, perform those actions. If this does not resolve the problem, go to [PFW1546-1](#).
  - ◆ If an additional slow boot has not been performed, or if the slow boot did not yield a new error code, look at the error that occurred prior to the original error. Perform the actions associated with that error. If the problem is not resolved, go to [PFW1546-1](#).
  - ◆ If a slow boot results in the same error code, and there are no error codes before the original error code, go to [PFW1546-1](#).
2. The service processor might have been set by the user to monitor system operations and to attempt recoveries. You might want to disable these options while you diagnose and service the system. If these settings are disabled, make notes of their current settings so that they can be restored before the system is turned back over to the customer. The following settings may be of interest.

| Setting                                                | Description                                                                                                                                                     |
|--------------------------------------------------------|-----------------------------------------------------------------------------------------------------------------------------------------------------------------|
| Monitoring (also called surveillance)                  | From the ASMI menu, expand the System Configuration menu, then click on Monitoring. Disable both types of surveillance.                                         |
| Auto power restart (also called unattended start mode) | From the ASMI menu, expand Power/Restart Control, then click on Auto Power Restart, and set it to disabled.                                                     |
| Wake on LAN                                            | From the ASMI menu, expand Wake on LAN, and set it to disabled.                                                                                                 |
| Call Out                                               | From the ASMI menu, expand the Service Aids menu, then click on Call-Home/Call-In Setup. Set the call-home system port and the call-in system port to disabled. |

3. If this is a ESCALA PL Series system, verify that the system has not been set to boot to the SMS menus or to the open firmware prompt. From the ASMI menu, expand Power/Restart Control to view the menu, then click on Power On/Off System. The AIX/Linux partition mode boot should say "Continue to Operating System".

- **PFW1546-1**

Record the error code(s) and location codes(s) that sent you to this procedure.

- **PFW1546-2**

Use the HMC to power off the system.

Examine the amber logic-power LEDs on all of the processor subsystem DCAs.

- **PFW1546-3**

**Are all of the amber logic-power LEDs on all of the processor subsystem DCAs off?**

NO

Contact service support.

YES

Continue to [PFW1546-4](#).

- **PFW1546-4**

**Attention:** Some of the parts in the following lists have a limit of three plugging cycles.

Replace the following memory cards, one at a time, in the order listed, if present.

1. The device at the first location code recorded in [PFW1546-1](#).
2. The device at the second location code recorded in [PFW1546-1](#).
3. The device at the third location code recorded in [PFW1546-1](#).
4. The device at the fourth location code recorded in [PFW1546-1](#).
5. The device at the fifth location code recorded in [PFW1546-1](#).
6. The device at the sixth location code recorded in [PFW1546-1](#).

- **PFW1546-5**

Turn on the power.

- **PFW1546-6**

**Did the system stop with the same error code as recorded in step 1546-1?**

NO

The memory card just replace was defective. Return the system to its original configuration. Go to [MAP 0410: Repair Checkout](#). This ends the procedure.

YES

Go to [PFW1546-7](#).

- **PFW1546-7**

**Have all of the memory cards listed in step 1546-4 been replaced?**

NO

Go to [PFW1546-2](#).

YES

Go to [PFW1546-8](#).

- **PFW1546-8**

Turn off the power.

- **PFW1546-9**

Examine the amber logic-power LEDs on all of the processor subsystem DCAs.

- **PFW1546-10**

**Are all of the amber logic-power LEDs on all of the processor subsystem DCAs off?**

NO

Contact service support.

YES

Continue to [PFW1546-11](#).

- **PFW1546-11**

Using the memory card plugging sequence table shown below, depopulate the memory cards in the system according to the following.

**Note:** As each node is removed, record the configuration of memory cards before removing any.

- ◆ In a one-node system with only one MCM active (in a model ESCALA PL 6450R only), leave the first two memory cards in the table installed.
- ◆ In a one-node system with both MCMs active, leave the first four memory cards in the table installed.
- ◆ In a two-node system, leave the first eight memory cards in the table installed.
- ◆ In a three-node system, leave the first twelve memory cards in the table installed.
- ◆ In a four-node system, leave the first sixteen memory cards in the table installed.

Table 1. Memory card plugging sequences for multi-node systems

| 16W System  | 32W System  | 48W System  | 64W System  |
|-------------|-------------|-------------|-------------|
| Node 0 MC01 | Node 0 MC01 | Node 0 MC01 | Node 0 MC01 |
| Node 0 MC02 | Node 0 MC02 | Node 0 MC02 | Node 0 MC02 |
| Node 0 MC03 | Node 1 MC01 | Node 1 MC01 | Node 1 MC01 |
| Node 0 MC04 | Node 1 MC02 | Node 1 MC02 | Node 1 MC02 |
| Node 0 MC05 | Node 0 MC03 | Node 2 MC01 | Node 2 MC01 |
| Node 0 MC06 | Node 0 MC04 | Node 2 MC02 | Node 2 MC02 |
| Node 0 MC15 | Node 1 MC03 | Node 0 MC03 | Node 3 MC01 |
| Node 0 MC16 | Node 1 MC04 | Node 0 MC04 | Node 3 MC02 |
| Node 0 MC08 | Node 0 MC05 | Node 1 MC03 | Node 0 MC03 |
| Node 0 MC09 | Node 0 MC06 | Node 1 MC04 | Node 0 MC04 |
| Node 0 MC12 | Node 1 MC05 | Node 2 MC03 | Node 1 MC03 |
| Node 0 MC13 | Node 1 MC06 | Node 2 MC04 | Node 1 MC04 |

Service provider information

|             |             |             |             |
|-------------|-------------|-------------|-------------|
| Node 0 MC07 | Node 0 MC15 | Node 0 MC05 | Node 2 MC03 |
| Node 0 MC10 | Node 0 MC16 | Node 0 MC06 | Node 2 MC04 |
| Node 0 MC11 | Node 1 MC15 | Node 1 MC05 | Node 3 MC03 |
| Node 0 MC14 | Node 1 MC16 | Node 1 MC06 | Node 3 MC04 |
|             | Node 0 MC08 | Node 2 MC05 | Node 0 MC05 |
|             | Node 0 MC09 | Node 2 MC06 | Node 0 MC06 |
|             | Node 1 MC08 | Node 0 MC15 | Node 1 MC05 |
|             | Node 1 MC09 | Node 0 MC16 | Node 1 MC06 |
|             | Node 0 MC12 | Node 1 MC15 | Node 2 MC05 |
|             | Node 0 MC13 | Node 1 MC16 | Node 2 MC06 |
|             | Node 1 MC12 | Node 2 MC15 | Node 3 MC05 |
|             | Node 1 MC13 | Node 2 MC16 | Node 3 MC06 |
|             | Node 0 MC07 | Node 0 MC08 | Node 0 MC15 |
|             | Node 0 MC10 | Node 0 MC09 | Node 0 MC16 |
|             | Node 1 MC07 | Node 1 MC08 | Node 1 MC15 |
|             | Node 1 MC10 | Node 1 MC09 | Node 1 MC16 |
|             | Node 0 MC11 | Node 2 MC08 | Node 2 MC15 |
|             | Node 0 MC14 | Node 2 MC09 | Node 2 MC16 |
|             | Node 1 MC11 | Node 0 MC12 | Node 3 MC15 |
|             | Node 1 MC14 | Node 0 MC13 | Node 3 MC16 |
|             |             | Node 1 MC12 | Node 0 MC08 |
|             |             | Node 1 MC13 | Node 0 MC09 |
|             |             | Node 2 MC12 | Node 1 MC08 |
|             |             | Node 2 MC13 | Node 1 MC09 |
|             |             | Node 0 MC07 | Node 2 MC08 |
|             |             | Node 0 MC10 | Node 2 MC09 |
|             |             | Node 1 MC07 | Node 3 MC08 |
|             |             | Node 1 MC10 | Node 3 MC09 |
|             |             | Node 2 MC07 | Node 0 MC12 |
|             |             | Node 2 MC10 | Node 0 MC13 |
|             |             | Node 0 MC11 | Node 1 MC12 |
|             |             | Node 0 MC14 | Node 1 MC13 |
|             |             | Node 1 MC11 | Node 2 MC12 |
|             |             | Node 1 MC14 | Node 2 MC13 |
|             |             | Node 2 MC11 | Node 3 MC12 |
|             |             | Node 2 MC14 | Node 3 MC13 |
|             |             |             | Node 0 MC07 |
|             |             |             | Node 0 MC10 |
|             |             |             | Node 1 MC07 |
|             |             |             | Node 1 MC10 |
|             |             |             | Node 2 MC07 |
|             |             |             | Node 2 MC10 |
|             |             |             | Node 3 MC07 |
|             |             |             | Node 3 MC10 |
|             |             |             | Node 0 MC11 |
|             |             |             | Node 0 MC14 |
|             |             |             | Node 1 MC11 |
|             |             |             | Node 1 MC14 |
|             |             |             | Node 2 MC11 |

Service provider information

|  |  |  |             |
|--|--|--|-------------|
|  |  |  | Node 2 MC14 |
|  |  |  | Node 3 MC11 |
|  |  |  | Node 3 MC14 |

Reinstall the nodes into the system.

After the system has been taken down to the minimum memory for the number of nodes in the system, power on the system using the HMC.

**Does the system boot to server firmware standby with no error codes on the control panel?**

NO

Go to [PFW1546-12](#).

YES

Go to [PFW1546-18](#).

• **PFW1546-12**

The following steps will isolate the failing node. The nodes will be removed, repopulated with memory, and added back to the system one at a time.

Use the HMC to power down the system.

Remove all nodes from the system.

Reconfigure the memory in the first node according to the first column in the table in [PFW1546-11](#).

Reinstall the first node, then use the HMC to power on the system.

**Does the system boot to server firmware standby with no error codes on the control panel?**

NO

Go to [PFW1546-13](#).

YES

Go to [PFW1546-14](#).

• **PFW1546-13**

The failure has been isolated to the node that was just reinstalled. Do the following in the order listed:

1. Use the HMC to power down the system.
2. Remove the last node that was reinstalled. Replace the eight memory cards in the node with eight known-good cards, or eight cards from the ones that were removed in [PFW1546-11](#).
3. Reinstall the node.
4. Use the HMC to power up the system.

**Does the system boot to server firmware standby with no error codes on the control panel?**

NO

Before replacing the node's backplane and chassis, or one of the MCMs, call the support center. This ends the procedure.

YES

One of the eight memory cards originally in this node is bad. Isolate to the failing quad first, then isolate the failing memory card. Replace the failing card, then go to [MAP 0410: Repair Checkout](#). This ends the procedure.

• **PFW1546-14**

Use the HMC to power down the system.

**Is there a second node in the system?**

NO

Go to [PFW1546-17](#).

YES

Do the following:

1. Reconfigure the minimum memory in the first node and the second node according to the second column in the table in [PFW1546-11](#).

2. Reinstall the second node, then use the HMC to power on the system.

**Does the system boot to server firmware standby with no error codes on the control panel?**

NO

Go to [PFW1546-13](#).

YES

Go to [PFW1546-15](#).

• **PFW1546-15**

Use the HMC to power down the system.

**Is there a third node in the system?**

NO

Go to [PFW1546-17](#).

YES

Do the following:

1. Reconfigure the minimum memory in the first node, the second node, and the third node according to the second column in the table in [PFW1546-11](#).
2. Reinstall the third node, then use the HMC to power on the system.

**Does the system boot to server firmware standby with no error codes on the control panel?**

NO

Go to [PFW1546-13](#).

YES

Go to [PFW1546-16](#).

• **PFW1546-16**

Use the HMC to power down the system.

**Is there a fourth node in the system?**

NO

Go to [PFW1546-17](#).

YES

Do the following:

1. Reconfigure the minimum memory in the first node, the second node, the third node, and the fourth node according to the second column in the table in [PFW1546-11](#).
2. Reinstall the third node, then use the HMC to power on the system.

**Does the system boot to server firmware standby with no error codes on the control panel?**

NO

Go to [PFW1546-13](#).

YES

Go to [PFW1546-17](#).

• **PFW1546-17**

The system now boots to server firmware standby with the minimum configuration of memory cards. Go to [PFW1546-18](#) to start adding back in the additional memory in the system.

• **PFW1546-18**

Power off the system using the HMC.

Add another set of four memory cards back in order, one set a time, according to the table in [PFW1546-11](#).

After each set of four is added, reinstall the node into the system.

**Does the system boot to server firmware standby with no error codes on the control panel?**

NO

Go to [PFW1546-20](#).

YES

Go to [PFW1546-19](#).

• **PFW1546-19**

**Has the last set of four memory cards been installed (so the system has been returned to its original configuration)?**

NO

Go to [PFW1546-18](#).

YES

The system is now booting to server firmware standby with all of the memory cards installed. Go to [MAP 0410: Repair Checkout](#). This ends the procedure.

• **PFW1546-20**

The set of four memory cards that was reinstalled in step 18, or the slots into which they were installed, are causing the failure.

Do the following:

1. Power down the system using the HMC.
2. Remove the node into which the last set of memory cards was installed.
3. Replace the last set of memory cards that was installed with a known-good set.
4. Reinstall the node in the system.
5. Using the HMC, power on the system.

**Does the system boot to server firmware standby with no error codes on the control panel?**

NO

One or more of the memory slots is bad. Before replacing the chassis, contact the support center. This ends the procedure.

YES

Go to [PFW1546-21](#).

• **PFW1546-21**

One or more of the memory cards in the last set installed is bad. Using the known good set, swap out the memory cards one at a time until the failing card is isolated. Replace it. Return the system to its original configuration, then go to [MAP 0410: Repair Checkout](#). This ends the procedure.

**Parent topic:** [Problems with loading and starting the operating system \(AIX and Linux\)](#)

---

## **PFW1548: Memory and processor subsystem problem isolation procedure**

### **Purpose of this procedure**

This MAP is used to locate defective FRUs not found by normal diagnostics. For this procedure, diagnostics are run on a minimally configured system. If a failure is detected on the minimally configured system, the remaining FRUs are exchanged one at a time until the failing FRU is identified. If a failure is not detected, FRUs are added back until the failure occurs. The failure is then isolated to the failing FRU.

**Note:** This MAP assumes that either:

- An optical drive is installed and connected to the integrated EIDE adapter, and an AIX diagnostic CD-ROM is available.

OR

- AIX standalone diagnostics can be booted from a NIM server.

Do the following:



1. Be sure to unplug the power cords before removing or installing any part to avoid damage to it.
2. If a power-on password or privileged-access password is set, you are prompted to enter the password before the AIX diagnostic CD-ROM can load.
3. The term POST indicators refers to the device mnemonics that appear during the power-on self-test (POST).
4. If your system is a model ESCALA PL 245T/R , go to step 8. Otherwise, continue to the next step.
5. The service processor might have recorded one or more symptoms in its error/event log. Use the Advanced System Management Interface (ASMI) menus to view the error/event log.
  - ◆ If you arrived here after performing a slow boot, look for a possible new error that occurred during the slow boot. If there is a new error, and its actions call for a FRU replacement, perform those actions. If this does not resolve the problem, select one of the files listed below according to the system model you are servicing, then go to PFW1548-xxx-1 in that procedure.
  - ◆ If an additional slow boot has not been performed, or if the slow boot did not yield a new error code, look at the error that occurred just before the original error. Perform the actions associated with that error. If the problem is not resolved, select one of the files listed below according to the system model you are servicing, then go to PFW1548-xxx-1 in that procedure.
  - ◆ If a slow boot results in the same error code, and there are no error codes before the original error code, select one of the files listed below according to the system model you are servicing, then go to PFW1548-xxx-1 in that procedure.
6. The service processor might have been set by the user to monitor system operations and to attempt recoveries. You might want to disable these options while you diagnose and service the system. If these settings are disabled, make notes of their current settings so that they can be restored before the system is turned back over to the customer. The following settings may be of interest.

#### Monitoring

(also called surveillance) From the ASMI menu, expand the System Configuration menu, then click on Monitoring. Disable both types of surveillance.

#### Auto power restart

(also called unattended start mode) From the ASMI menu, expand Power/Restart Control, then click on Auto Power Restart, and set it to disabled.

#### Wake on LAN

From the ASMI menu, expand Wake on LAN, and set it to disabled.

#### Call Out

From the ASMI menu, expand the Service Aids menu, then click on Call-Home/Call-In Setup. Set the call-home system port and the call-in system port to disabled.

7. If this is a ESCALA PL Series system, verify that the system has not been set to boot to the System Management Services (SMS) menus or to the open firmware prompt. From the ASMI menu, expand Power/Restart Control to view the menu, then click on Power On/Off System. The AIX/Linux partition mode boot should say "Continue to Operating System". Go to step 10.
8. On a model ESCALA PL 245T/R ystem, the SMS menus might have been used by the customer to enable auto power restart and wake-on-LAN. You might want to disable these options while you diagnose and service the system. Before you disable these settings, make notes of their current values so that you can restore them before turning the system back over to the customer. The following settings may be of interest.

#### Auto power restart

(also called unattended start mode) On the SMS main menu, expand Power/Restart Control, then click on Auto Power Restart, and set it to disabled.

#### Wake on LAN

On the SMS main menu, expand Power/Restart Control, then click on Auto Power Restart, and set it to disabled.

9. On a model ESCALA PL 245T/R ystem, the SMS menus may have been used by the customer to enable multiboot at startup. You can disable multiboot starting the the main SMS menu by selecting Select Boot Options > Multiboot Startup.
  - ◆ To have the system boot to the SMS menus automatically each time it reboots, enable this flag.
  - ◆ To have the system boot to the operating system each time it reboots, disable this flag.
 In either case, record the customer's setting and return it to that setting after you complete the service actions.
10. To continue with this procedure select one of the following files according to the model system you are servicing.
  - ◆ [PFW1548-185: Processor subsystem problem isolation procedure for model ESCALA PL 245T/R](#)
  - ◆ [PFW1548-505: Processor subsystem problem isolation procedure for model ESCALA PL 250R-VL or ESCALA PL 450R-XS with an HMC attached](#)
  - ◆ [PFW1548-505: Processor subsystem problem isolation procedure for model ESCALA PL 250R-VL or ESCALA PL 450R-XS without an HMC attached](#)

- ◆ PFW1548-510: Processor subsystem problem isolation procedure for model ESCALA PL 250R-L, ESCALA PL 250R-L+ or ESCALA PL 450R-VL+, with an HMC attached
- ◆ PFW1548-510: Processor subsystem problem isolation procedure for model ESCALA PL 250R-L, ESCALA PL 250R-L+ or ESCALA PL 450R-VL+, without an HMC attached
- ◆ PFW1548-520: Processor subsystem problem isolation procedure for the model ESCALA PL 250T/R, ESCALA PL 250T/R+ or ESCALA PL 450T/R-L+, with an HMC
- ◆ PFW1548-520: Processor subsystem problem isolation procedure for the model ESCALA PL 250T/R, ESCALA PL 250T/R+ or ESCALA PL 450T/R-L+, without an HMC
- ◆ PFW1548-550: Processor subsystem problem isolation procedure for models ESCALA PL 450T/R, ESCALA PL 450T/R+ or ESCALA PL 850T/R-L+, with an HMC
- ◆ PFW1548-550: Processor subsystem problem isolation procedure for models ESCALA PL 450T/R, ESCALA PL 450T/R+ or ESCALA PL 850T/R-L+, without an HMC attached
- ◆ PFW1548-570: Processor subsystem problem isolation procedure for models ESCALA PL 1650R-L+ and ESCALA PL 850R/PL 1650R/R+
- ◆ PFW1548-575: Processor subsystem problem isolation procedure for model 5/75
- ◆ PFW1543: Model ESCALA PL 3250R and model ESCALA PL 6450R MCM problem isolation procedure

Parent topic: [Problems with loading and starting the operating system \(AIX and Linux\)](#)

---

## PFW1548-520: Processor subsystem problem isolation procedure for the model ESCALA PL 250T/R, ESCALA PL 250T/R+ or ESCALA PL 450T/R-L+, and 112/85 with an HMC

Use this problem isolation procedure to aid in solving memory and processor problems on ESCALA PL 250T/R, ESCALA PL 250T/R+ or ESCALA PL 450T/R-L+, and 112/85 models attached to an HMC.

- PFW1548-520-1

1. Insure that the diagnostics and the operating system(s) are shut down.

**Is the system at "service processor standby", indicated by "01" in the control panel?**

NO

Replace the service processor card, location: Un-P1-C8. Return to the beginning of step [PFW1548-520-1](#).

YES

Continue with substep 2.

2. Turn on the power using either the white button or the HMC.

**Does the managed system reach power on at hypervisor standby as indicated on the HMC?**

NO

Go to step [PFW1548-520-3](#).

YES

Go to step [PFW1548-520-2](#).

- PFW1548-520-2

1. Insert the AIX diagnostic CD-ROM into the optical drive.

**Note:** If you cannot insert the diagnostic CD-ROM, go to [PFW1548-520-3](#).

2. Turn on the power using either the HMC or the white button. (If the diagnostic CD-ROM is not in the optical drive, insert it now.) After the system has reached hypervisor standby, activate a Linux or AIX partition by clicking on the "Advanced" button on the activation screen. On the "advanced" activation screen, select "boot in service mode using the default boot list" to boot the diagnostic CD-ROM.

3. If you are prompted to do so, enter the appropriate password.

**Is the "Please define the System Console" screen displayed?**

NO

Go to step [PFW1548-520-3](#).

YES

Go to step [PFW1548-520-23](#).

## • PFW1548-520-3

1. Turn off the power.
2. If you have not already done so, configure the service processor (using the ASMI menus) with the instructions in note 6 at the beginning of this procedure, then return here and continue.
3. Exit the service processor (ASMI) menus and remove the power cords.
4. Disconnect all external cables (parallel, system port 1, system port 2, keyboard, mouse, Ethernet on the system planar, Ethernet on the service processor if present, and so on). Leave the Ethernet cable between the service processor and the HMC attached.
5. Remove the service access cover (model xxx), or place the drawer (model yyy), into the service position and remove the service access cover.
6. Record the slot numbers of the PCI adapters. Label and record the locations of all cables attached to the adapters. Disconnect all cables attached to the adapters and remove all of the adapters.
7. Disconnect all of the power and signal cables from the media drives located in media bay.
8. Remove the media drives.
9. Record the slot numbers of the memory DIMMs on the system backplane. Remove all memory DIMMs except for one pair from the system backplane.

**Notes:**

- a. Place the memory DIMM locking tabs in the locked (upright) position to prevent damage to the tabs.
- b. Memory DIMMs must be installed in pairs and in the correct connectors. Refer to the memory DIMM section of [Locations-Model ESCALA PL 250T/R](#) for information on memory DIMMs.

10. Disconnect the IDE cable from the IDE connector on the system backplane.
11. If the system is equipped with a diskette drive, disconnect the diskette drive cable from the diskette drive connector on the system backplane.
12. Disconnect the signal and power connectors from both disk drive backplanes.
13. Disconnect the disk drives from both disk drive backplanes.
14. Plug in the power cords and wait for "01" in the upper-left corner of the control panel display.
15. Turn on the power using either the HMC or the white button. (If the diagnostic CD-ROM is not in the optical drive, insert it now.) After the system has reached hypervisor standby, activate a Linux or AIX partition by clicking on the "Advanced" button on the activation screen. On the "advanced" activation screen, select "boot in service mode using the default boot list" to boot the diagnostic CD-ROM.

**Does the system stop with B1xxF22A, CA00E1F2, CA00E1F3, or STBY displayed on the control panel?**

NO

Go to [PFW1548-520-7](#).

YES

Go to [PFW1548-520-4](#).

## • PFW1548-520-4

**Were any memory DIMMs removed from the system backplane?**

NO

Go to [PFW1548-520-9](#).

YES

Go to [PFW1548-520-5](#).

## • PFW1548-520-5

1. Turn off the power, and remove the power cords.
2. Replug the memory DIMMs that were removed from the system backplane in [PFW1548-520-2](#) in their original locations.

**Notes:**

- a. Place the memory DIMM locking tabs into the locked (upright) position to prevent damage to the tabs.
  - b. Memory DIMMs must be installed in pairs in the correct connectors. Refer to [Memory DIMM locations](#) for information on memory DIMMs.
3. Plug in the power cords and wait for "01" in the control panel display.
  4. Turn on the power using either the HMC or the white button. (If the diagnostic CD-ROM is not in the optical drive, insert it now.) After the system has reached hypervisor standby, activate a Linux or AIX partition by clicking on the "Advanced" button on the activation screen. On the "advanced" activation screen, select "boot in service mode using the default boot list" to boot the diagnostic CD-ROM.

**Does the system stop with B1xxF22A, CA00E1F2, CA00E1F3, or STBY displayed on the control panel?**

NO

A memory DIMM in the pair you just replaced in the system is defective. Turn off the power, remove the power cords, and exchange the memory DIMMs in that pair one at a time with new or previously removed memory DIMMs. Repeat this step until the defective memory DIMM is identified, or all memory DIMMs have been exchanged.

If your symptom did not change and all the memory DIMMs have been exchanged, call your service support person for assistance.

If the symptom changed, check for loose cards and obvious problems.

If you do not find a problem, go to the [Start-of-call procedure](#) and follow the instructions for the new symptom.

YES

Go to [PFW1548-520-9](#).

- PFW1548-520-6

This step is reserved.

- PFW1548-520-7

One of the FRUs remaining in the system unit is defective.

**Note:** If a memory DIMM is exchanged, insure that the new memory DIMM is the same size and speed as the original memory DIMM.

1. Turn off the power, remove the power cords, and exchange the following FRUs in the order listed:
  - a. Memory DIMMs. Exchange one at a time with new or previously removed DIMMs
  - b. Service processor
  - c. System backplane
  - d. Power supplies.
2. Plug in the power cords and wait for "01" in the upper-left corner of the control panel display.
3. Turn on the power using either the HMC or the white button. (If the diagnostic CD-ROM is not in the optical drive, insert it now.) After the system has reached hypervisor standby, activate a Linux or AIX partition by clicking on the "Advanced" button on the activation screen. On the "advanced" activation screen, select "boot in service mode using the default boot list" to boot the diagnostic CD-ROM.

**Does the system stop with B1xxF22A, CA00E1F2, CA00E1F3, or STBY displayed on the control panel?**

NO

Reinstall the original FRU. Repeat the FRU replacement steps until the defective FRU is identified or all the FRUs have been exchanged.

If the symptom did not change and all the FRUs have been exchanged, call service support for assistance.

If the symptom has changed, check for loose cards, cables, and obvious problems.

If you do not find a problem, go to the [Start-of-call procedure](#) and follow the instructions for the new symptom.

YES

Go to [MAP 0410: Repair Checkout](#).

• PFW1548-520-8

This step is reserved.

• PFW1548-520-9

1. Turn off the power.
2. Reconnect the system console.
  - a. If an ASCII terminal has been defined as the firmware console, attach the ASCII terminal cable to the S1 connector on the rear of the system unit.
  - b. If a display attached to a display adapter has been defined as the firmware console, install the display adapter and connect the display to the adapter. Plug the keyboard and mouse into the keyboard connector on the rear of the system unit.
3. Turn on the power using either the HMC or the white button. (If the diagnostic CD-ROM is not in the optical drive, insert it now.) After the system has reached hypervisor standby, activate a Linux or AIX partition by clicking on the "Advanced" button on the activation screen. On the "advanced" activation screen, select "boot in service mode using the default boot list" to boot the diagnostic CD-ROM.
4. If the ASCII terminal or graphics display (including display adapter) is connected differently from the way it was previously, the console selection screen appears. Select a firmware console.
5. When the word keyboard is displayed, press the number 1 key on the directly attached keyboard, an ASCII terminal or HMC. This activates the system management services (SMS).
6. Enter the appropriate password if you are prompted to do so.

**Is the SMS screen displayed?**

NO

One of the FRUs remaining in the system unit is defective.

1. Exchange the FRUs that have not been exchanged, in the following order:
  - Replace the service processor, location Un-P1-C7.
  - Replace the system backplane, location Un-P1.
2. If you are using a graphics display, go to the problem determination procedures for the display.

If you do not find a problem, do the following:

- Replace the display adapter.
- Replace the backplane in which the graphics adapter is plugged.

Repeat this step until the defective FRU is identified or all the FRUs have been exchanged.

If the symptom did not change and all the FRUs have been exchanged, call service support for assistance.

If the symptom changed, check for loose cards, cables, and obvious problems.

If you do not find a problem, go to the [Start-of-call procedure](#) and follow the instructions for the new symptom.

YES

Go to [PFW1548-520-10](#).

• PFW1548-520-10

1. Make sure the diagnostic CD-ROM is inserted into the optical drive.
2. Turn off the power and remove the power cords.
3. Plug the IDE cable into the IDE connector on the system backplane.
4. Connect the signal and power connectors to the IDE optical drive.
5. Plug in the power cords and wait for "01" in the upper-left corner of the control panel display.
6. Turn on the power using either the HMC or the white button. (If the diagnostic CD-ROM is not in the optical drive, insert it now.) After the system has reached hypervisor standby, activate a Linux or AIX partition by clicking on the "Advanced" button on the activation screen. On the "advanced" activation screen, select "boot in service mode using the default boot list" to boot the diagnostic CD-ROM.
7. Insert the diagnostic CD-ROM into the optical drive.
8. After the word keyboard is displayed, press the number 5 key on either the directly attached keyboard or an ASCII terminal keyboard.
9. Enter the appropriate password if you are prompted to do so.

**Is the Please define the System Console screen displayed?**

NO

One of the FRUs remaining in the system unit is defective.

Exchange the FRUs that have not been exchanged, in the following order:

1. IDE cable
2. Optical drive
3. Media backplane
4. System backplane

Repeat this step until the defective FRU is identified or all the FRUs have been exchanged.

If the symptom did not change and all the FRUs have been exchanged, call service support for assistance.

If the symptom has changed, check for loose cards, cables, and obvious problems.

If you do not find a problem, go to the [Start-of-call procedure](#) and follow the instructions for the new symptom.

YES

Go to [PFW1548-520-11](#).

- PFW1548-520-11

The system is working correctly with this configuration. One of the SCSI devices that was disconnected may be defective.

1. Make sure the diagnostic CD-ROM is inserted into the optical drive.
2. Turn off the power and remove the power cords.
3. Plug the SCSI cable into the SCSI connector on the system backplane.
4. Connect the signal and power connectors to one of the SCSI devices if present (a SCSI LVD tape device in media bay #1, for example). Do not connect the signal and power connectors to the disk drive backplane at this time.
5. Plug in the power cords and wait for "01" in the upper-left corner of the control panel display.
6. Turn on the power using either the HMC or the white button. (If the diagnostic CD-ROM is not in the optical drive, insert it now.) After the system has reached hypervisor standby, activate a Linux or AIX partition by clicking on the "Advanced" button on the activation screen. On the "advanced" activation screen, select "boot in service mode using the default boot list" to boot the diagnostic CD-ROM.
7. After the word keyboard is displayed, press the number 5 key on either the directly attached keyboard or on an ASCII terminal keyboard.
8. Enter the appropriate password if you are prompted to do so.

**Is the Please define the System Console screen displayed?**

NO

One of the FRUs remaining in the system unit is defective.

Exchange the FRUs that have not been exchanged, in the following order:

1. SCSI cable
2. Last SCSI device connected (for example, tape drive)
3. System backplane

Repeat this step until the defective FRU is identified or all the FRUs have been exchanged.

If the symptom did not change and all the FRUs have been exchanged, call service support for assistance.

If the symptom has changed, check for loose cards, cables, and obvious problems.

If you do not find a problem, go to the [Start-of-call procedure](#) and follow the instructions for the new symptom.

YES

Repeat this step, adding one SCSI device at a time, until all the SCSI devices that were attached to the integrated SCSI adapter, except the disk drive backplanes, are connected and tested. Go to [PFW1548-520-12](#).

- PFW1548-520-12

The system is working correctly with this configuration. One of the disk drive backplanes may be defective.

1. Make sure the diagnostic CD-ROM is inserted into the optical drive.
2. Turn off the power and remove the power cords.
3. Connect the signal and power connectors to one of the disk drive backplanes.
4. Plug in the power cords and wait for "01" in the upper-left corner of the control panel display.
5. Turn on the power using either the HMC or the white button. (If the diagnostic CD-ROM is not in the optical drive, insert it now.) After the system has reached hypervisor standby, activate a Linux or AIX partition by clicking on the "Advanced" button on the activation screen. On the "advanced" activation screen, select "boot in service mode using the default boot list" to boot the diagnostic CD-ROM.
6. If the Console Selection screen is displayed, choose the system console.
7. After the word keyboard is displayed, press the number 5 key on either the directly attached keyboard or an ASCII terminal keyboard.
8. Enter the appropriate password if you are prompted to do so.

**Is the Please define the System Console screen displayed?**

NO

One of the FRUs remaining in the system unit is defective.

Exchange the FRUs that have not been exchanged, in the following order:

1. SCSI cable
2. Disk drive backplane

Repeat this step until the defective FRU is identified or all the FRUs have been exchanged.

If the symptom did not change and all the FRUs have been exchanged, call service support for assistance.

If the symptom has changed, check for loose cards, cables, and obvious problems.

If you do not find a problem, go to the [Start-of-call procedure](#) and follow the instructions for the new symptom.

YES

If both disk drive backplanes have been reconnected, go to [PFW1548-520-13](#). Otherwise, repeat [PFW1548-520-12](#) for the other disk drive backplane if present.

• [PFW1548-520-13](#)

The system is working correctly with this configuration. One of the disk drives that you removed from the disk drive backplanes may be defective.

1. Make sure the diagnostic CD-ROM is inserted into the optical drive.
2. Turn off the power and remove the power cords.
3. Install a disk drive in a disk drive backplane.
4. Plug in the power cords and wait for the OK prompt to display on the control panel display.
5. Turn on the power using either the HMC or the white button. (If the diagnostic CD-ROM is not in the optical drive, insert it now.) After the system has reached hypervisor standby, activate a Linux or AIX partition by clicking on the "Advanced" button on the activation screen. On the "advanced" activation screen, select "boot in service mode using the default boot list" to boot the diagnostic CD-ROM.
6. After the word keyboard is displayed, press the number 5 key on either the directly attached keyboard or an ASCII terminal keyboard.
7. Enter the appropriate password if you are prompted to do so.

**Is the Please define the System Console screen displayed?**

NO

Exchange the FRUs that have not been exchanged, in the following order:

1. Last disk drive installed
2. Disk drive backplane where the disk drive was installed

Repeat this step until the defective FRU is identified or all the FRUs have been exchanged. If the symptom did not change and all the FRUs have been exchanged, call service support for assistance.

If the symptom has changed, check for loose cards, cables, and obvious problems.

If you do not find a problem, go to the [Start-of-call procedure](#) and follow the instructions for the new symptom.

YES

Repeat this step with all disk drives that were installed in the disk drive backplanes.

If the system has a diskette drive, go to [PFW1548-520-14](#), if not go to [PFW1548-520-15](#).

- PFW1548-520-14

The system is working correctly with this configuration. The diskette drive may be defective.

1. Make sure the diagnostic CD-ROM is inserted into the optical drive.
2. Turn off the power and remove the power cords.
3. Plug the diskette drive cable into the diskette drive connector on the system backplane.
4. Connect the signal and power connectors to the diskette drive.
5. Plug in the power cords and wait for "01" in the upper-left corner of the control panel display.
6. Turn on the power using either the HMC or the white button. (If the diagnostic CD-ROM is not in the optical drive, insert it now.) After the system has reached hypervisor standby, activate a Linux or AIX partition by clicking on the "Advanced" button on the activation screen. On the "advanced" activation screen, select "boot in service mode using the default boot list" to boot the diagnostic CD-ROM.
7. After the word keyboard displays, press the number 5 key on either the directly attached keyboard or on an ASCII terminal keyboard.
8. Enter the appropriate password if you are prompted to do so.

**Is the Please define the System Console screen displayed?**

NO

One of the FRUs remaining in the system is defective.

Exchange the FRUs that have not been exchanged, in the following order:

1. Diskette drive
2. Diskette drive cable
3. System backplane

Repeat this step until the defective FRU is identified or all the FRUs have been exchanged.

If the symptom did not change and all the FRUs have been exchanged, call service support for assistance.

If the symptom has changed, check for loose cards, cables, and obvious problems.

If you do not find a problem return, go to the [Start-of-call procedure](#) and follow the instructions for the new symptom.

YES

Go to [PFW1548-520-15](#).

- PFW1548-520-15

The system is working correctly with this configuration. One of the devices that was disconnected from the system backplane may be defective.

1. Turn off the power and remove the power cords.
2. Attach a system backplane device (for example: parallel, system port 1, system port 2, system port 3, keyboard, mouse, Ethernet, Ultra-2 SCSI,) that had been removed.
3. Plug in the power cords and wait for "01" in the upper-left corner on the control panel display.
4. Turn on the power using either the HMC or the white button. (If the diagnostic CD-ROM is not in the optical drive, insert it now.) After the system has reached hypervisor standby, activate a Linux or AIX partition by clicking on the "Advanced" button on the activation screen. On the "advanced" activation screen, select "boot in service mode using the default boot list" to boot the diagnostic CD-ROM.
5. If the Console Selection screen is displayed, choose the system console.
6. After the word keyboard displays, press the number 5 key on either the directly attached keyboard or on an ASCII terminal keyboard.
7. Enter the appropriate password if you are prompted to do so.

**Is the Please define the System Console screen displayed?**

NO

The last device or cable that you attached is defective.



To test each FRU, exchange the FRUs in the following order:

1. Device and cable (last one attached)
2. System backplane

If the symptom did not change and all the FRUs have been exchanged, call service support for assistance.

If the symptom has changed, check for loose cards, cables, and obvious problems.

If you do not find a problem, go to the [Start-of-call procedure](#) and follow the instructions for the new symptom. Go to [MAP 0410: Repair Checkout](#).

YES

Repeat this step until all of the devices are attached. Go to [PFW1548-520-16](#).

• PFW1548-520-16

The system is working correctly with this configuration. One of the FRUs (adapters) that you removed may be defective.

1. Turn off the power and remove the power cords.
2. Install a FRU (adapter) and connect any cables and devices that were attached to the FRU.
3. Plug in the power cords and wait for the OK prompt to display on the control panel display.
4. Turn on the power using either the HMC or the white button. (If the diagnostic CD-ROM is not in the optical drive, insert it now.) After the system has reached hypervisor standby, activate a Linux or AIX partition by clicking on the "Advanced" button on the activation screen. On the "advanced" activation screen, select "boot in service mode using the default boot list" to boot the diagnostic CD-ROM.
5. If the Console Selection screen is displayed, choose the system console.
6. After the word keyboard displays, press the number 5 key on either the directly attached keyboard or on an ASCII terminal keyboard.
7. Enter the appropriate password if you are prompted to do so.

**Is the Please define the System Console screen displayed?**

NO

Go to [PFW1548-520-17](#).

YES

Repeat this step until all of the FRUs (adapters) are installed. Go to [MAP 0410: Repair Checkout](#).

• PFW1548-520-17

The last FRU installed or one of its attached devices is probably defective.

1. Make sure the diagnostic CD-ROM is inserted into the optical drive.
2. Turn off the power and remove the power cords.
3. Starting with the last installed adapter, disconnect one attached device and cable.
4. Plug in the power cords and wait for the "01" in the upper-left corner on the control panel display.
5. Turn on the power using either the HMC or the white button. (If the diagnostic CD-ROM is not in the optical drive, insert it now.) After the system has reached hypervisor standby, activate a Linux or AIX partition by clicking on the "Advanced" button on the activation screen. On the "advanced" activation screen, select "boot in service mode using the default boot list" to boot the diagnostic CD-ROM.
6. If the Console Selection screen is displayed, choose the system console.
7. After the word keyboard displays, press the number 5 key on either the directly attached keyboard or on an ASCII terminal keyboard.
8. Enter the appropriate password if you are prompted to do so.

**Is the Please define the System Console screen displayed?**

NO

Repeat this step until the defective device or cable is identified or all devices and cables have been disconnected.

If all the devices and cables have been removed, then one of the FRUs remaining in the system unit is defective.

To test each FRU, exchange the FRUs in the following order:

1. Adapter (last one installed)

## 2. System backplane

If the symptom did not change and all the FRUs have been exchanged, call service support for assistance.

If the symptom has changed, check for loose cards, cables, and obvious problems.

If you do not find a problem, go to the [Start-of-call procedure](#) and follow the instructions for the new symptom.

YES

The last device or cable that you disconnected is defective. Exchange the defective device or cable. Go to [MAP 0410: Repair Checkout](#).

- PFW1548-520-18

1. Follow the instructions on the screen to select the system console.
2. When the DIAGNOSTIC OPERATING INSTRUCTIONS screen is displayed, press Enter.
3. Select Advanced Diagnostics Routines.
4. If the terminal type has not been defined, you must use the initialize terminal option on the FUNCTION SELECTION menu to initialize the AIX diagnostic environment before you can continue with the diagnostics. This is a separate operation from selecting the console display.
5. If the NEW RESOURCE screen is displayed, select an option from the bottom of the screen.

**Note:** Adapters and devices that require supplemental media are not shown in the new resource list. If the system has adapters or devices that require supplemental media, select option 1.

6. When the DIAGNOSTIC MODE SELECTION screen is displayed, press Enter.
7. Select All Resources. (If you were sent here from [PFW1548-520-21](#), select the adapter or device that was loaded from the supplemental media).

Did you get an SRN?

NO

Go to [PFW1548-520-20](#).

YES

Go to [PFW1548-520-19](#).

- PFW1548-520-19

Look at the FRU part numbers associated with the SRN.

### Have you exchanged all the FRUs that correspond to the failing function codes (FFCs)?

NO

Exchange the FRU with the highest failure percentage that has not been changed.

Repeat this step until all the FRUs associated with the SRN have been exchanged or diagnostics run with no trouble found. Run diagnostics after each FRU is exchanged. Go to [MAP 0410: Repair Checkout](#).

YES

If the symptom did not change and all the FRUs have been exchanged, call service support for assistance.

- PFW1548-520-20

### Does the system have adapters or devices that require supplemental media?

NO

Go to [PFW1548-520-21](#).

YES

Go to [PFW1548-520-22](#).

- PFW1548-520-21

Consult the PCI adapter configuration documentation for your operating system to verify that all adapters are configured correctly. Go to [MAP 0410: Repair Checkout](#).

If the symptom did not change and all the FRUs have been exchanged, call service support for assistance.

- PFW1548-520-22

1. Select Task Selection.
2. Select Process Supplemental Media and follow the on screen instructions to process the media. Supplemental media must be loaded and processed one at a time.

**Did the system return to the TASKS SELECTION SCREEN after the supplemental media was processed?**

NO

Go to [PFW1548-520-23](#).

YES

Press F3 to return to the FUNCTION SELECTION screen. Go to [step 4](#).

- PFW1548-520-23

The adapter or device is probably defective.

If the supplemental media is for an adapter, replace the FRUs in the following order:

1. Adapter
2. System backplane

If the supplemental media is for a device, replace the FRUs in the following order:

1. Device and any associated cables
2. The adapter to which the device is attached

Repeat this step until the defective FRU is identified or all the FRUs have been exchanged.

If the symptom did not change and all the FRUs have been exchanged, call service support for assistance.

If the symptom has changed, check for loose cards, cables, and obvious problems.

If you do not find a problem, go to the [Start-of-call procedure](#) and follow the instructions for the new symptom. Go to [MAP 0410: Repair Checkout](#).

End of procedure.

## **PFW1548-520: Processor subsystem problem isolation procedure for the model ESCALA PL 250T/R, ESCALA PL 250T/R+ or ESCALA PL 450T/R-L+, and 112/85 without an HMC**

Use this problem isolation procedure to aid in solving memory and processor problems on for the model ESCALA PL 250T/R, ESCALA PL 250T/R+ or ESCALA PL 450T/R-L+, and 112/85 models that are not attached to an HMC.

- PFW1548-520-1a
  1. Insure that the diagnostics and the operating system(s) are shut down.
  2. Turn on the power.
  3. Insert the AIX diagnostic CD-ROM into the optical drive.

**Note:** If you cannot insert the diagnostic CD-ROM, go to [PFW1548-520-2a](#).

4. When the keyboard indicator is displayed on the system console:
  - ◇ On an ASCII terminal or directly-attached keyboard, press the number 5 key.
5. If you are prompted to do so, enter the appropriate password.

**Is the "Please define the System Console" screen displayed?**

NO

Go to step [PFW1548-520-2a](#).

YES

Go to step [PFW1548-520-17a](#).

- PFW1548-520-2a

1. Turn on the power.

2. If you have not already done so, configure the service processor (using the ASMI menus) with the instructions in note 6 at the beginning of this MAP, then return here and continue.
3. Exit the service processor (ASMI) menus and remove the power cords.
4. Disconnect all external cables (parallel, system port 1, system port 2, keyboard, mouse, Ethernet on the system planar, Ethernet on the service processor if present, and so on).
5. Remove the service access cover (model xxx), or place the drawer (model yyy), into the service position and remove the service access cover.
6. Record the slot numbers of the PCI adapters. Label and record the locations of all cables attached to the adapters. Disconnect all cables attached to the adapters and remove all of the adapters.
7. Disconnect all of the power and signal cables from the media drives located in the media bay.
8. Remove the media drives.
9. Record the slot numbers of the memory DIMMs on the system backplane. Remove all memory DIMMs except for one pair from the system backplane.

**Notes:**

- a. Place the memory DIMM locking tabs in the locked (upright) position to prevent damage to the tabs.
  - b. Memory DIMMs must be installed in pairs and in the correct connectors. Refer to "Memory DIMM Locations" for information on memory DIMMs.
10. Disconnect the IDE cable from the IDE connector on the system backplane.
  11. If the system is equipped with a diskette drive, disconnect the diskette drive cable from the diskette drive connector on the system backplane.
  12. Disconnect the signal and power connectors from both disk drive backplanes.
  13. Disconnect the disk drives from both disk drive backplanes.
  14. Plug in the power cords and wait for "01" in the upper-left-hand corner of the control panel display.
  15. Turn on the power.

**Does the system stop with B1xxF22A, CA00E1F2, CA00E1F3, or STBY displayed on the control panel?**

NO

Go to step [PFW1548-520-6a](#).

YES

Go to step [PFW1548-520-3a](#).

- PFW1548-520-3a

**Were any memory DIMMs removed from the system backplane?**

NO

Go to step [PFW1548-520-8a](#).

YES

Go to step [PFW1548-520-4a](#).

- PFW1548-520-4a
  1. Turn off the power, and remove the power cords.
  2. Replug the memory DIMMs that were removed from the system backplane in step PFW1548-520-2 in their original locations.

**Notes:**

- a. Place the memory DIMM locking tabs into the locked (upright) position to prevent damage to the tabs.
  - b. Memory DIMMs must be installed in pairs in the correct connectors. Refer to "Memory DIMM Locations" for information on memory DIMMs.
3. Plug in the power cords and wait for "01" in the control panel display.
  4. Turn on the power.

**Does the system stop with B1xxF22A, CA00E1F2, CA00E1F3, or STBY displayed on the control panel?**

NO

A memory DIMM in the pair you just replaced in the system is defective. Turn off the power, remove the power cords, and exchange the memory DIMMs in that pair one at a time with new or previously removed memory DIMMs. Repeat this step until the defective memory DIMM is identified, or all memory DIMMs have been exchanged.

If your symptom did not change and all the memory DIMMs have been exchanged, call your service support person for assistance.

If the symptom changed, check for loose cards and obvious problems.

If you do not find a problem, go to the [Start-of-Call MAP](#) and follow the instructions for the new symptom.

YES

Go to [PFW1548-520-8a](#).

- PFW1548-520-5a

This step is reserved.

- PFW1548-520-6a

One of the FRUs remaining in the system unit is defective.

**Note:** If a memory DIMM is exchanged, insure that the new memory DIMM is the same size and speed as the original memory DIMM.

1. Turn off the power, remove the power cords, and exchange the following FRUs in the order listed:
  - a. Memory DIMMs. Exchange one at a time with new or previously removed DIMMs
  - b. Service processor
  - c. System backplane
  - d. Power supplies.
2. Plug in the power cords and wait for "01" in the upper-left corner of the control panel display.
3. Turn on the power.

**Does the system stop with B1xxF22A, CA00E1F2, CA00E1F3, or STBY displayed on the control panel?**

NO

Reinstall the original FRU. Repeat the FRU replacement steps until the defective FRU is identified or all the FRUs have been exchanged.

If the symptom did not change and all the FRUs have been exchanged, call service support for assistance.

If the symptom has changed, check for loose cards, cables, and obvious problems.

If you do not find a problem, go to the [Start-of-call procedure](#) and follow the instructions for the new symptom.

YES

Go to [MAP 0410: Repair Checkout](#).

- PFW1548-520-7a

This step is reserved.

- PFW1548-520-8a

1. Turn off the power.
2. Reconnect the system console.
  - a. If an ASCII terminal has been defined as the firmware console, attach the ASCII terminal cable to the S1 connector on the rear of the system unit.
  - b. If a display attached to a display adapter has been defined as the firmware console, install the display adapter and connect the display to the adapter. Plug the keyboard and mouse into the keyboard connector on the rear of the system unit.
3. Turn on the power.
4. If the ASCII terminal or graphics display (including display adapter) is connected differently from the way it was previously, the console selection screen appears. Select a firmware console.

5. When the word keyboard is displayed, press the number 1 key on the directly attached keyboard, an ASCII terminal or HMC. This activates the system management services (SMS).
6. Enter the appropriate password if you are prompted to do so.

**Is the SMS screen displayed?**

NO

One of the FRUs remaining in the system unit is defective.

1. Exchange the FRUs that have not been exchanged, in the following order:
  - Replace the service processor, location Un-P1-C7.
  - Replace the system backplane, location Un-P1.
2. If you are using a graphics display, go to the problem determination procedures for the display.

If you do not find a problem, do the following:

- Replace the display adapter.
- Replace the backplane in which the graphics adapter is plugged.

Repeat this step until the defective FRU is identified or all the FRUs have been exchanged.

If the symptom did not change and all the FRUs have been exchanged, call service support for assistance.

If the symptom changed, check for loose cards, cables, and obvious problems.

If you do not find a problem, go to the [Start-of-call procedure](#) and follow the instructions for the new symptom.

YES

Go to [PFW1548-520-9a](#).

• PFW1548-520-9a

1. Make sure the diagnostic CD-ROM is inserted into the optical drive.
2. Turn off the power and remove the power cords.
3. Plug the IDE cable into the IDE connector on the system backplane.
4. Connect the signal and power connectors to the IDE optical drive.
5. Plug in the power cords and wait for "01" in the upper-left corner of the control panel display.
6. Turn on the power.
7. Insert the diagnostic CD-ROM into the optical drive.
8. After the word keyboard is displayed, press the number 5 key on either the directly attached keyboard or an ASCII terminal keyboard.
9. Enter the appropriate password if you are prompted to do so.

**Is the Please define the System Console screen displayed?**

NO

One of the FRUs remaining in the system unit is defective.

Exchange the FRUs that have not been exchanged, in the following order:

1. IDE cable
2. Optical drive
3. Media backplane
4. System backplane

Repeat this step until the defective FRU is identified or all the FRUs have been exchanged.

If the symptom did not change and all the FRUs have been exchanged, call service support for assistance.

If the symptom has changed, check for loose cards, cables, and obvious problems.

If you do not find a problem, go to the [Start-of-call procedure](#) and follow the instructions for the new symptom.

YES

Go to [PFW1548-520-10a](#).

• PFW1548-520-10a

The system is working correctly with this configuration. One of the SCSI devices that was disconnected may be defective.

1. Make sure the diagnostic CD-ROM is inserted into the optical drive.
2. Turn off the power and remove the power cords.
3. Plug the SCSI cable into the SCSI connector on the system backplane.
4. Connect the signal and power connectors to one of the SCSI devices if present (a SCSI LVD tape device in media bay #1, for example). Do not connect the signal and power connectors to the disk drive backplane at this time.
5. Plug in the power cords and wait for "01" in the upper-left corner of the control panel display.
6. Turn on the power.
7. After the word keyboard is displayed, press the number 5 key on either the directly attached keyboard or on an ASCII terminal keyboard.
8. Enter the appropriate password if you are prompted to do so.

**Is the Please define the System Console screen displayed?**

NO

One of the FRUs remaining in the system unit is defective.

Exchange the FRUs that have not been exchanged, in the following order:

1. SCSI cable
2. Last SCSI device connected (for example, tape drive)
3. System backplane

Repeat this step until the defective FRU is identified or all the FRUs have been exchanged.

If the symptom did not change and all the FRUs have been exchanged, call service support for assistance.

If the symptom has changed, check for loose cards, cables, and obvious problems.

If you do not find a problem, go to the [Start-of-call procedure](#) and follow the instructions for the new symptom.

YES

Repeat this step, adding one SCSI device at a time, until all the SCSI devices that were attached to the integrated SCSI adapter, except the disk drive backplanes, are connected and tested. Go to [PFW1548-520-11a](#).

- PFW1548-520-11a

The system is working correctly with this configuration. One of the disk drive backplanes may be defective.

1. Make sure the diagnostic CD-ROM is inserted into the optical drive.
2. Turn off the power and remove the power cords.
3. Connect the signal and power connectors to one of the disk drive backplanes.
4. Plug in the power cords and wait for "01" in the upper-left corner of the control panel display.
5. Turn on the power.
6. If the Console Selection screen is displayed, choose the system console.
7. After the word keyboard is displayed, press the number 5 key on either the directly attached keyboard or an ASCII terminal keyboard.
8. Enter the appropriate password if you are prompted to do so.

**Is the Please define the System Console screen displayed?**

NO

One of the FRUs remaining in the system unit is defective.

Exchange the FRUs that have not been exchanged, in the following order:

1. SCSI cable
2. Disk drive backplane

Repeat this step until the defective FRU is identified or all the FRUs have been exchanged.

If the symptom did not change and all the FRUs have been exchanged, call service support for assistance.

If the symptom has changed, check for loose cards, cables, and obvious problems.

If you do not find a problem, go to the [Start-of-call procedure](#) and follow the instructions for the new symptom.

YES

If both disk drive backplanes have been reconnected, go to [PFW1548-520-12a](#). Otherwise, repeat PFW1548-520-11a for the other disk drive backplane if present.

- PFW1548-520-12a

The system is working correctly with this configuration. One of the disk drives that you removed from the disk drive backplanes may be defective.

1. Make sure the diagnostic CD-ROM is inserted into the optical drive.
2. Turn off the power and remove the power cords.
3. Install a disk drive in a disk drive backplane.
4. Plug in the power cords and wait for the OK prompt to display on the control panel display.
5. Turn on the power.
6. After the word keyboard is displayed, press the number 5 key on either the directly attached keyboard or an ASCII terminal keyboard.
7. Enter the appropriate password if you are prompted to do so.

**Is the Please define the System Console screen displayed?**

NO

Exchange the FRUs that have not been exchanged, in the following order:

1. Last disk drive installed
2. Disk drive backplane where the disk drive was installed

Repeat this step until the defective FRU is identified or all the FRUs have been exchanged. If the symptom did not change and all the FRUs have been exchanged, call service support for assistance.

If the symptom has changed, check for loose cards, cables, and obvious problems.

If you do not find a problem, go to the [Start-of-call procedure](#) and follow the instructions for the new symptom.

YES

Repeat this step with all disk drives that were installed in the disk drive backplanes.

If the system has a diskette drive, go to [PFW1548-520-13a](#), if not go to [PFW1548-520-14a](#).

- PFW1548-520-13a

The system is working correctly with this configuration. The diskette drive may be defective.

1. Make sure the diagnostic CD-ROM is inserted into the optical drive.
2. Turn off the power and remove the power cords.
3. Plug the diskette drive cable into the diskette drive connector on the system backplane.
4. Connect the signal and power connectors to the diskette drive.
5. Plug in the power cords and wait for "01" in the upper-left corner of the control panel display.
6. Turn on the power.
7. After the word keyboard displays, press the number 5 key on either the directly attached keyboard or on an ASCII terminal keyboard.
8. Enter the appropriate password if you are prompted to do so.

**Is the Please define the System Console screen displayed?**

NO

One of the FRUs remaining in the system is defective.

Exchange the FRUs that have not been exchanged, in the following order:

1. Diskette drive
2. Diskette drive cable
3. System backplane

Repeat this step until the defective FRU is identified or all the FRUs have been exchanged. If the symptom did not change and all the FRUs have been exchanged, call service support for assistance.

If the symptom has changed, check for loose cards, cables, and obvious problems.

If you do not find a problem return, go to the [Start-of-call procedure](#) and follow the instructions for the new symptom.

YES

Go to [PFW1548-520-14a](#).

- PFW1548-520-14a



The system is working correctly with this configuration. One of the devices that was disconnected from the system backplane may be defective.

1. Turn off the power and remove the power cords.
2. Attach a system backplane device (for example: parallel, system port 1, system port 2, system port 3, keyboard, mouse, Ethernet, Ultra-2 SCSI,) that had been removed.
3. Plug in the power cords and wait for "01" in the upper-left corner on the control panel display.
4. Turn on the power.
5. If the Console Selection screen is displayed, choose the system console.
6. After the word keyboard displays, press the number 5 key on either the directly attached keyboard or on an ASCII terminal keyboard.
7. Enter the appropriate password if you are prompted to do so.

**Is the Please define the System Console screen displayed?**

NO

The last device or cable that you attached is defective.

To test each FRU, exchange the FRUs in the following order:

1. Device and cable (last one attached)
2. System backplane

If the symptom did not change and all the FRUs have been exchanged, call service support for assistance.

If the symptom has changed, check for loose cards, cables, and obvious problems.

If you do not find a problem, go to the [Start-of-call procedure](#) and follow the instructions for the new symptom. Go to [MAP 0410: Repair Checkout](#).

YES

Repeat this step until all of the devices are attached. Go to [PFW1548-520-15a](#).

• PFW1548-520-15a

The system is working correctly with this configuration. One of the FRUs (adapters) that you removed may be defective.

1. Turn off the power and remove the power cords.
2. Install a FRU (adapter) and connect any cables and devices that were attached to the FRU.
3. Plug in the power cords and wait for the OK prompt to display on the control panel display.
4. Turn on the power.
5. If the Console Selection screen is displayed, choose the system console.
6. After the word keyboard displays, press the number 5 key on either the directly attached keyboard or on an ASCII terminal keyboard.
7. Enter the appropriate password if you are prompted to do so.

**Is the Please define the System Console screen displayed?**

NO

Go to [PFW1548-520-16a](#).

YES

Repeat this step until all of the FRUs (adapters) are installed. Go to [MAP 0410: Repair Checkout](#).

• PFW1548-520-16a

The last FRU installed or one of its attached devices is probably defective.

1. Make sure the diagnostic CD-ROM is inserted into the optical drive.
2. Turn off the power and remove the power cords.
3. Starting with the last installed adapter, disconnect one attached device and cable.
4. Plug in the power cords and wait for the "01" in the upper-left corner on the control panel display.
5. Turn on the power.
6. If the Console Selection screen is displayed, choose the system console.
7. After the word keyboard displays, press the number 5 key on either the directly attached keyboard or on an ASCII terminal keyboard.
8. Enter the appropriate password if you are prompted to do so.

**Is the Please define the System Console screen displayed?**

NO

Repeat this step until the defective device or cable is identified or all devices and cables have been disconnected.

If all the devices and cables have been removed, then one of the FRUs remaining in the system unit is defective.

To test each FRU, exchange the FRUs in the following order:

1. Adapter (last one installed)
2. System backplane

If the symptom did not change and all the FRUs have been exchanged, call service support for assistance.

If the symptom has changed, check for loose cards, cables, and obvious problems.

If you do not find a problem, go to the [Start-of-call procedure](#) and follow the instructions for the new symptom.

YES

The last device or cable that you disconnected is defective. Exchange the defective device or cable. Go to [MAP 0410: Repair Checkout](#).

• PFW1548-520-17a

1. Follow the instructions on the screen to select the system console.
2. When the DIAGNOSTIC OPERATING INSTRUCTIONS screen is displayed, press Enter.
3. Select Advanced Diagnostics Routines.
4. If the terminal type has not been defined, you must use the initialize terminal option on the FUNCTION SELECTION menu to initialize the AIX diagnostic environment before you can continue with the diagnostics. This is a separate operation from selecting the console display.
5. If the NEW RESOURCE screen is displayed, select an option from the bottom of the screen.

**Note:** Adapters and devices that require supplemental media are not shown in the new resource list. If the system has adapters or devices that require supplemental media, select option 1.

6. When the DIAGNOSTIC MODE SELECTION screen is displayed, press Enter.
7. Select All Resources. (If you were sent here from [PFW1548-520-21a](#), select the adapter or device that was loaded from the supplemental media).

Did you get an SRN?

NO

Go to [PFW1548-520-19a](#).

YES

Go to [PFW1548-520-18a](#).

• PFW1548-520-18a

Look at the FRU part numbers associated with the SRN.

Have you exchanged all the FRUs that correspond to the failing function codes (FFCs)?

NO

Exchange the FRU with the highest failure percentage that has not been changed.

Repeat this step until all the FRUs associated with the SRN have been exchanged or diagnostics run with no trouble found. Run diagnostics after each FRU is exchanged. Go to [MAP 0410: Repair Checkout](#).

YES

If the symptom did not change and all the FRUs have been exchanged, call service support for assistance.

• PFW1548-520-19a

**Does the system have adapters or devices that require supplemental media?**

NO

Go to [PFW1548-520-20a](#).

YES

Go to [PFW1548-520-21a](#).

- PFW1548-520-20a

Consult the PCI adapter configuration documentation for your operating system to verify that all adapters are configured correctly. Go to [MAP 0410: Repair Checkout](#).

If the symptom did not change and all the FRUs have been exchanged, call service support for assistance.

- PFW1548-520-21a

1. Select Task Selection.

2. Select Process Supplemental Media and follow the on screen instructions to process the media. Supplemental media must be loaded and processed one at a time.

**Did the system return to the TASKS SELECTION SCREEN after the supplemental media was processed?**

NO

Go to [PFW1548-520-22a](#).

YES

Press F3 to return to the FUNCTION SELECTION screen. Go to [step 4](#).

- PFW1548-520-22a

The adapter or device is probably defective.

If the supplemental media is for an adapter, replace the FRUs in the following order:

1. Adapter
2. System backplane

If the supplemental media is for a device, replace the FRUs in the following order:

1. Device and any associated cables
2. The adapter to which the device is attached

Repeat this step until the defective FRU is identified or all the FRUs have been exchanged.

If the symptom did not change and all the FRUs have been exchanged, call service support for assistance.

If the symptom has changed, check for loose cards, cables, and obvious problems.

If you do not find a problem, go to the [Start-of-call procedure](#) and follow the instructions for the new symptom. Go to [MAP 0410: Repair Checkout](#).

End of procedure.

---

## **PFW1548-550: Processor subsystem problem isolation procedure for models ESCALA PL 450T/R, ESCALA PL 450T/R+ or ESCALA PL 850T/R-L+, with an HMC**

Use this problem isolation procedure to aid in solving memory and processor problems on ESCALA PL 450T/R, ESCALA PL 450T/R+ or ESCALA PL 850T/R-L+, models attached to an HMC.

- PFW1548-550-1

Insure that the diagnostics and the operating system are shut down.

**Is the system at "service processor standby", indicated by "01" in the control panel?**

NO

Replace the service processor card, location: Un-P1-C8. Return to the beginning of step 1548-1.

YES

YES Continue with substep 1.

1. Turn on the power using either the HMC or the white button.

**Does the managed system reach power on at hypervisor standby as indicated on the HMC?**

NO

Go to step [PFW1548-550-3](#).

YES

Go to step [PFW1548-550-2](#).

## • PFW1548-550-2

1. Insert the AIX diagnostic CD-ROM into the optical drive.

**Note:** If you cannot insert the diagnostic CD-ROM, go to [PFW1548-550-3](#).

2. Turn on the power using either the HMC or the white button. (If the diagnostic CD-ROM is not in the optical drive, insert it now.) After the system has reached hypervisor standby, activate a Linux or AIX partition by clicking on the "Advanced" button on the activation screen. On the "advanced" activation screen, select "boot in service mode using the default boot list" to boot the diagnostic CD-ROM.
3. If you are prompted to do so, enter the appropriate password.

**Is the Please define the System Console screen displayed?**

NO

Go to [PFW1548-550-3](#).

YES

Go to [PFW1548-550-23](#).

## • PFW1548-550-3

1. Turn off the power.
2. If you have not already done so, configure the service processor (using the ASMI menus) with the instructions in note 6 at the beginning of the PFW1548 procedure, then return here and continue.
3. Exit the service processor (ASMI) menus and remove the power cords.
4. Disconnect all external cables (parallel, system port 1, system port 2, keyboard, mouse, USB devices, SPCN, Ethernet on the system planar, Ethernet on the service processor if present, and so on).
5. Remove the service access cover (model xxx), or place the drawer (model yyy), into the service position and remove the service access cover.
6. Record the slot numbers of the PCI adapters. Label and record the locations of all cables attached to the adapters. Disconnect all cables attached to the adapters and remove all of the adapters.
7. Disconnect all of the power and signal cables from the media drives located in media bay 1 and media bay 2.
8. Remove the media drives.
9. Record the slot numbers of the memory DIMMs on processor card #1. Remove all memory DIMMs except for one quad from processor card #1.

**Notes:**

- a. Place the memory DIMM locking tabs in the locked (upright) position to prevent damage to the tabs.
  - b. Memory DIMMs must be installed in pairs and in the correct connectors. Refer to the memory DIMM section of [Locations-Model ESCALA PL 450T/R](#) for information on memory DIMMs.
10. Disconnect the IDE cable from the IDE connector on the system backplane.
  11. If the system is equipped with a diskette drive, disconnect the diskette drive cable from the diskette drive connector on the system backplane.
  12. Disconnect the signal and power connectors from the disk drive backplane.
  13. Disconnect the disk drives from both disk drive backplanes.
  14. Plug in the power cords and wait for "01" in the upper-left corner of the operator panel display.
  15. Turn on the power using either the HMC or the white button. (If the diagnostic CD-ROM is not in the optical drive, insert it now.) After the system has reached hypervisor standby, activate a Linux or AIX partition by clicking on the "Advanced" button on the activation screen. On the

"advanced" activation screen, select "boot in service mode using the default boot list" to boot the diagnostic CD-ROM.

**Does the system stop with B1xxF22A, CA00E1F2, CA00E1F3, or STBY displayed on the operator panel?**

NO

Go to [PFW1548-550-7](#).

YES

Go to [PFW1548-550-4](#).

- PFW1548-550-4

**Were any memory DIMMs removed from the system backplane?**

NO

Go to [PFW1548-550-9](#).

YES

Go to [PFW1548-550-5](#).

- PFW1548-550-5
  1. Turn off the power, and remove the power cords.
  2. Replug the memory DIMMs that were removed from the system backplane in [PFW1548-550-3](#) in their original locations.

**Notes:**

- a. Place the memory DIMM locking tabs into the locked (upright) position to prevent damage to the tabs.
  - b. Memory DIMMs must be installed in pairs in the correct connectors. Refer to [Memory DIMM locations](#) for information on memory DIMMs.
3. Plug in the power cords and wait for "01" in the upper-left corner of the operator panel display.
  4. Turn on the power using either the HMC or the white button. (If the diagnostic CD-ROM is not in the optical drive, insert it now.) After the system has reached hypervisor standby, activate a Linux or AIX partition by clicking on the "Advanced" button on the activation screen. On the "advanced" activation screen, select "boot in service mode using the default boot list" to boot the diagnostic CD-ROM.

**Does the system stop with B1xxF22A, CA00E1F2, CA00E1F3, or STBY displayed on the operator panel?**

NO

A memory DIMM in the pair you just replaced in the system is defective. Turn off the power, remove the power cords, and exchange the memory DIMMs in that pair one at a time with new or previously removed memory DIMMs. Repeat this step until the defective memory DIMM is identified, or all memory DIMMs have been exchanged.

If your symptom did not change and all the memory DIMMs have been exchanged, call your service support person for assistance.

If the symptom changed, check for loose cards and obvious problems.

If you do not find a problem, go to the [Start-of-call procedure](#) and follow the instructions for the new symptom.

YES

Go to [PFW1548-550-8](#).

- PFW1548-550-6

This step is reserved.

- PFW1548-550-7

One of the FRUs remaining in the system unit is defective.

**Note:** If a memory DIMM is exchanged, insure that the new memory DIMM is the same size and speed as the original memory DIMM.

1. Turn off the power, remove the power cords, and exchange the following FRUs in the order listed:
  - a. Memory DIMMs. Exchange one at a time with new or previously removed DIMMs
  - b. Service processor
  - c. System backplane
  - d. Power supplies
2. Plug in the power cords and wait for "01" in the upper-left corner of the operator panel display.
3. Turn on the power using either the HMC or the white button. (If the diagnostic CD-ROM is not in the optical drive, insert it now.) After the system has reached hypervisor standby, activate a Linux or AIX partition by clicking on the "Advanced" button on the activation screen. On the "advanced" activation screen, select "boot in service mode using the default boot list" to boot the diagnostic CD-ROM.

**Does the system stop with B1xxF22A, CA00E1F2, CA00E1F3, or STBY displayed on the operator panel?**

NO

Reinstall the original FRU.

Repeat the FRU replacement steps until the defective FRU is identified or all the FRUs have been exchanged.

If the symptom did not change and all the FRUs have been exchanged, call service support for assistance.

If the symptom has changed, check for loose cards, cables, and obvious problems.

If you do not find a problem, go to the [Start-of-call procedure](#) and follow the instructions for the new symptom.

YES

Go to [MAP 0410: Repair Checkout](#).

- PFW1548-550-8

This step is reserved.

- PFW1548-550-9
  1. Turn off the power.
  2. Reconnect the system console.

**Notes:**

- a. If an ASCII terminal has been defined as the firmware console, attach the ASCII terminal cable to the S1 connector on the rear of the system unit.
  - b. If a display attached to a display adapter has been defined as the firmware console, install the display adapter and connect the display to the adapter. Plug the keyboard and mouse into the keyboard connector on the rear of the system unit.
3. Turn on the power using either the HMC or the white button. (If the diagnostic CD-ROM is not in the optical drive, insert it now.) After the system has reached hypervisor standby, activate a Linux or AIX partition by clicking on the "Advanced" button on the activation screen. On the "advanced" activation screen, select "boot in service mode using the default boot list" to boot the diagnostic CD-ROM.
  4. If the ASCII terminal or graphics display (including display adapter) is connected differently from the way it was previously, the console selection screen appears. Select a firmware console.
  5. When the word keyboard is displayed, press the number 1 key on the directly attached keyboard, an ASCII terminal or HMC. This activates the system management services (SMS).
  6. Enter the appropriate password if you are prompted to do so.

**Is the SMS screen displayed?**

NO

One of the FRUs remaining in the system unit is defective.

Exchange the FRUs that have not been exchanged, in the following order:

1.
  - a. Service processor, location: Un-P1-C7.
  - b. System backplane, location Un-P1.
2. If you are using a graphics display, go to the problem determination procedures for the display. If you do not find a problem, do the following:
  - a. Replace the display adapter.
  - b. Replace the backplane in which the graphics adapter is plugged.

Repeat this step until the defective FRU is identified or all the FRUs have been exchanged.

If the symptom did not change and all the FRUs have been exchanged, call service support for assistance.

If the symptom changed, check for loose cards, cables, and obvious problems.

If you do not find a problem, go to the [Start-of-call procedure](#) and follow the instructions for the new symptom.

YES

Go to [PFW1548-550-10](#).

• PFW1548-550-10

1. Make sure the diagnostic CD-ROM is inserted into the optical drive.
2. Turn off the power and remove the power cords.
3. Plug the IDE cable into the IDE connector on the system backplane.
4. Connect the signal and power connectors to the IDE optical drive.
5. Plug in the power cords and wait for "01" in the upper-left corner of the operator panel display.
6. Turn on the power using either the HMC or the white button. (If the diagnostic CD-ROM is not in the optical drive, insert it now.) After the system has reached hypervisor standby, activate a Linux or AIX partition by clicking on the "Advanced" button on the activation screen. On the "advanced" activation screen, select "boot in service mode using the default boot list" to boot the diagnostic CD-ROM.
7. Insert the diagnostic CD-ROM into the optical drive.
8. After the word keyboard is displayed, press the number 5 key on either the directly attached keyboard or an ASCII terminal keyboard.
9. Enter the appropriate password if you are prompted to do so.

**Is the Please define the System Console screen displayed?**

NO

One of the FRUs remaining in the system unit is defective.

Exchange the FRUs that have not been exchanged, in the following order:

1. IDE cable
2. Optical drive
3. Media backplane
4. System backplane

Repeat this step until the defective FRU is identified or all the FRUs have been exchanged.

If the symptom did not change and all the FRUs have been exchanged, call service support for assistance.

If the symptom has changed, check for loose cards, cables, and obvious problems.

If you do not find a problem, go to the [Start-of-call procedure](#) and follow the instructions for the new symptom.

YES

Go to [PFW1548-550-11](#).

• PFW1548-550-11

The system is working correctly with this configuration. One of the SCSI devices that was disconnected may be defective.

1. Make sure the diagnostic CD-ROM is inserted into the optical drive.
2. Turn off the power and remove the power cords.
3. Plug the SCSI cable into the SCSI connector on the system backplane.

4. Connect the signal and power connectors to one of the SCSI devices if present (a SCSI LVD tape device in media bay #1, for example). Do not connect the signal and power connectors to the disk drive backplane at this time.
5. Plug in the power cords and wait for "01" in the upper-left corner of the operator panel display.
6. Turn on the power using either the HMC or the white button. (If the diagnostic CD-ROM is not in the optical drive, insert it now.) After the system has reached hypervisor standby, activate a Linux or AIX partition by clicking on the "Advanced" button on the activation screen. On the "advanced" activation screen, select "boot in service mode using the default boot list" to boot the diagnostic CD-ROM.
7. After the word keyboard is displayed, press the number 5 key on either the directly attached keyboard or on an ASCII terminal keyboard.
8. Enter the appropriate password if you are prompted to do so.

**Is the Please define the System Console screen displayed?**

NO

One of the FRUs remaining in the system unit is defective.

Exchange the FRUs that have not been exchanged, in the following order:

1. SCSI cable
2. Last SCSI device connected (for example, tape drive)
3. System backplane

Repeat this step until the defective FRU is identified or all the FRUs have been exchanged.

If the symptom did not change and all the FRUs have been exchanged, call service support for assistance.

If the symptom has changed, check for loose cards, cables, and obvious problems.

If you do not find a problem, go to the [Start-of-call procedure](#) and follow the instructions for the new symptom.

YES

Repeat this step, adding one SCSI device at a time, until all the SCSI devices that were attached to the integrated SCSI adapter, except the disk drive backplanes, are connected and tested. Go to [PFW1548-550-12](#).

- PFW1548-550-12

The system is working correctly with this configuration. One of the disk drive backplanes may be defective.

1. Make sure the diagnostic CD-ROM is inserted into the optical drive.
2. Turn off the power and remove the power cords.
3. Connect the signal and power connectors to one of the disk drive backplanes.
4. Plug in the power cords and wait for "01" in the upper-left corner of the operator panel display.
5. Turn on the power using either the HMC or the white button. (If the diagnostic CD-ROM is not in the optical drive, insert it now.) After the system has reached hypervisor standby, activate a Linux or AIX partition by clicking on the "Advanced" button on the activation screen. On the "advanced" activation screen, select "boot in service mode using the default boot list" to boot the diagnostic CD-ROM.
6. If the Console Selection screen is displayed, choose the system console.
7. After the word keyboard is displayed, press the number 5 key on either the directly attached keyboard or an ASCII terminal keyboard.
8. Enter the appropriate password if you are prompted to do so.

**Is the Please define the System Console screen displayed?**

NO

One of the FRUs remaining in the system unit is defective.

Exchange the FRUs that have not been exchanged, in the following order:

1. SCSI cable
2. Disk drive backplane

Repeat this step until the defective FRU is identified or all the FRUs have been exchanged.



If the symptom did not change and all the FRUs have been exchanged, call service support for assistance.

If the symptom has changed, check for loose cards, cables, and obvious problems.

If you do not find a problem, go to the [Start-of-call procedure](#) and follow the instructions for the new symptom.

YES

If both disk drive backplanes have been reconnected, go to [PFW1548-550-13](#). Otherwise, repeat [PFW1548-550-12](#) for the other disk drive backplane if present.

- PFW1548-550-13

The system is working correctly with this configuration. One of the disk drives that you removed from the disk drive backplanes may be defective.

1. Make sure the diagnostic CD-ROM is inserted into the optical drive.
2. Turn off the power and remove the power cords.
3. Install a disk drive in a disk drive backplane.
4. Plug in the power cords and wait for the OK prompt to display on the operator panel display.
5. Turn on the power using either the HMC or the white button. (If the diagnostic CD-ROM is not in the optical drive, insert it now.) After the system has reached hypervisor standby, activate a Linux or AIX partition by clicking on the "Advanced" button on the activation screen. On the "advanced" activation screen, select "boot in service mode using the default boot list" to boot the diagnostic CD-ROM.
6. After the word keyboard is displayed, press the number 5 key on either the directly attached keyboard or an ASCII terminal keyboard.
7. Enter the appropriate password if you are prompted to do so.

**Is the Please define the System Console screen displayed?**

NO

Exchange the FRUs that have not been exchanged, in the following order:

1. Last disk drive installed
2. Disk drive backplane where the disk drive was installed

Repeat this step until the defective FRU is identified or all the FRUs have been exchanged.

If the symptom did not change and all the FRUs have been exchanged, call service support for assistance.

If the symptom has changed, check for loose cards, cables, and obvious problems.

If you do not find a problem, go to the [Start-of-call procedure](#) and follow the instructions for the new symptom.

YES

Repeat this step with all disk drives that were installed in the disk drive backplanes.

If the system has an internal diskette drive, go to [PFW1548-550-14](#), if not go to [PFW1548-550-15](#).

- PFW1548-550-14

The system is working correctly with this configuration. The diskette drive may be defective.

1. Make sure the diagnostic CD-ROM is inserted into the optical drive.
2. Turn off the power and remove the power cords.
3. Plug the diskette drive cable into the diskette drive connector on the system backplane.
4. Connect the signal and power connectors to the diskette drive.
5. Plug in the power cords and wait for "01" in the upper-left corner of the operator panel display.
6. Turn on the power using either the HMC or the white button. (If the diagnostic CD-ROM is not in the optical drive, insert it now.) After the system has reached hypervisor standby, activate a Linux or AIX partition by clicking on the "Advanced" button on the activation screen. On the "advanced" activation screen, select "boot in service mode using the default boot list" to boot the diagnostic CD-ROM.
7. After the word keyboard displays, press the number 5 key on either the directly attached keyboard or on an ASCII terminal keyboard.
8. Enter the appropriate password if you are prompted to do so.

**Is the Please define the System Console screen displayed?**

NO

One of the FRUs remaining in the system is defective.

Exchange the FRUs that have not been exchanged, in the following order:

1. Diskette drive
2. Diskette drive cable
3. System backplane

Repeat this step until the defective FRU is identified or all the FRUs have been exchanged.

If the symptom did not change and all the FRUs have been exchanged, call service support for assistance.

If the symptom has changed, check for loose cards, cables, and obvious problems.

If you do not find a problem return, go to the [Start-of-call procedure](#) and follow the instructions for the new symptom.

YES

Go to [PFW1548-550-15](#).

• PFW1548-550-15

The system is working correctly with this configuration. One of the devices that was disconnected from the system backplane may be defective.

1. Turn off the power and remove the power cords
2. Attach a system backplane device (for example: parallel, system port 1, system port 2, system port 3, keyboard, mouse, Ethernet, Ultra-2 SCSI) that had been removed.
3. Plug in the power cords and wait for "01" in the upper-left corner on the operator panel display.
4. Turn on the power using either the HMC or the white button. (If the diagnostic CD-ROM is not in the optical drive, insert it now.) After the system has reached hypervisor standby, activate a Linux or AIX partition by clicking on the "Advanced" button on the activation screen. On the "advanced" activation screen, select "boot in service mode using the default boot list" to boot the diagnostic CD-ROM.
5. If the Console Selection screen is displayed, choose the system console.
6. After the word keyboard displays, press the number 5 key on either the directly attached keyboard or on an ASCII terminal keyboard.
7. Enter the appropriate password if you are prompted to do so.

**Is the Please define the System Console screen displayed?**

NO

The last device or cable that you attached is defective.

To test each FRU, exchange the FRUs in the following order:

1. Device and cable (last one attached)
2. System backplane

If the symptom did not change and all the FRUs have been exchanged, call service support for assistance.

If the symptom has changed, check for loose cards, cables, and obvious problems.

If you do not find a problem, go to the [Start-of-call procedure](#) and follow the instructions for the new symptom. Go to [MAP 0410: Repair Checkout](#).

YES

Repeat this step until all of the devices are attached. Go to [PFW1548-550-16](#).

• PFW1548-550-16

The system is working correctly with this configuration. One of the FRUs (adapters) that you removed may be defective.

1. Turn off the power and remove the power cords.
2. Install a FRU (adapter) and connect any cables and devices that were attached to the FRU.
3. Plug in the power cords and wait for the OK prompt to display on the operator panel display.
4. Turn on the power using either the HMC or the white button. (If the diagnostic CD-ROM is not in the optical drive, insert it now.) After the system has reached hypervisor standby, activate a Linux or AIX partition by clicking on the "Advanced" button on the activation screen. On the

"advanced" activation screen, select "boot in service mode using the default boot list" to boot the diagnostic CD-ROM.

5. If the Console Selection screen is displayed, choose the system console.
6. After the word keyboard displays, press the number 5 key on either the directly attached keyboard or on an ASCII terminal keyboard.
7. Enter the appropriate password if you are prompted to do so.

**Is the Please define the System Console screen displayed?**

NO

Go to [PFW1548-550-17](#).

YES

Repeat this step until all of the FRUs (adapters) are installed. Go to [MAP 0410: Repair Checkout](#).

- PFW1548-550-17

The last FRU installed or one of its attached devices is probably defective.

1. Make sure the diagnostic CD-ROM is inserted into the optical drive.
2. Turn off the power and remove the power cords.
3. Starting with the last installed adapter, disconnect one attached device and cable.
4. Plug in the power cords and wait for the "01" in the upper-left corner on the operator panel display.
5. Turn on the power using either the HMC or the white button. (If the diagnostic CD-ROM is not in the optical drive, insert it now.) After the system has reached hypervisor standby, activate a Linux or AIX partition by clicking on the "Advanced" button on the activation screen. On the "advanced" activation screen, select "boot in service mode using the default boot list" to boot the diagnostic CD-ROM.
6. If the Console Selection screen is displayed, choose the system console.
7. After the word keyboard displays, press the number 5 key on either the directly attached keyboard or on an ASCII terminal keyboard.
8. Enter the appropriate password if you are prompted to do so.

**Is the Please define the System Console screen displayed?**

NO

Repeat this step until the defective device or cable is identified or all devices and cables have been disconnected.

If all the devices and cables have been removed, then one of the FRUs remaining in the system unit is defective.

To test each FRU, exchange the FRUs in the following order:

1. Adapter (last one installed)
2. System backplane

If the symptom did not change and all the FRUs have been exchanged, call service support for assistance.

If the symptom has changed, check for loose cards, cables, and obvious problems.

If you do not find a problem, go to the [Start-of-call procedure](#) and follow the instructions for the new symptom.

YES

The last device or cable that you disconnected is defective. Exchange the defective device or cable. Go to [MAP 0410: Repair Checkout](#).

- PFW1548-550-18

1. Follow the instructions on the screen to select the system console.
2. When the DIAGNOSTIC OPERATING INSTRUCTIONS screen is displayed, press Enter.
3. Select Advanced Diagnostics Routines.
4. If the terminal type has not been defined, you must use the initialize terminal option on the FUNCTION SELECTION menu to initialize the AIX diagnostic environment before you can continue with the diagnostics. This is a separate operation from selecting the console display.
5. If the NEW RESOURCE screen is displayed, select an option from the bottom of the screen.

**Note:** Adapters and devices that require supplemental media are not shown in the new resource list. If the system has adapters or devices that require supplemental media, select

option 1.

6. When the DIAGNOSTIC MODE SELECTION screen is displayed, press Enter.
7. Select All Resources. (If you were sent here from step PFW1548550-21, select the adapter or device that was loaded from the supplemental media).

Did you get an SRN?

NO

Go to [PFW1548-550-20](#).

YES

Go to [PFW1548-550-19](#).

- PFW1548-550-19

Look at the FRU part numbers associated with the SRN.

#### **Have you exchanged all the FRUs that correspond to the failing function codes (FFCs)?**

NO

Exchange the FRU with the highest failure percentage that has not been changed.

Repeat this step until all the FRUs associated with the SRN have been exchanged or diagnostics run with no trouble found. Run diagnostics after each FRU is exchanged. Go to [MAP 0410: Repair Checkout](#).

YES

If the symptom did not change and all the FRUs have been exchanged, call service support for assistance.

- PFW1548-550-20

#### **Does the system have adapters or devices that require supplemental media?**

NO

Go to [PFW1548-550-22](#).

YES

Go to [PFW1548-550-21](#).

- PFW1548-550-21

Consult the PCI adapter configuration documentation for your operating system to verify that all adapters are configured correctly. Go to [MAP 0410: Repair Checkout](#).

If the symptom did not change and all the FRUs have been exchanged, call service support for assistance.

- PFW1548-550-22

1. Select Task Selection.

2. Select Process Supplemental Media and follow the on screen instructions to process the media. Supplemental media must be loaded and processed one at a time.

#### **Did the system return to the TASKS SELECTION SCREEN after the supplemental media was processed?**

NO

Go to [PFW1548-550-23](#).

YES

Press F3 to return to the FUNCTION SELECTION screen. Go to [step 4](#).

- PFW1548-550-23

The adapter or device is probably defective.

If the supplemental media is for an adapter, replace the FRUs in the following order:

1. Adapter
2. System backplane

If the supplemental media is for a device, replace the FRUs in the following order:

1. Device and any associated cables
2. The adapter to which the device is attached

Repeat this step until the defective FRU is identified or all the FRUs have been exchanged.

If the symptom did not change and all the FRUs have been exchanged, call service support for assistance.

If the symptom has changed, check for loose cards, cables, and obvious problems.

If you do not find a problem, go to the [Start-of-call procedure](#) and follow the instructions for the new symptom. Go to [MAP 0410: Repair Checkout](#).

End of procedure.

## **PFW1548-550: Processor subsystem problem isolation procedure for models ESCALA PL 450T/R, ESCALA PL 450T/R+ or ESCALA PL 850T/R-L+, without an HMC attached**

Use this problem isolation procedure to aid in solving memory and processor problems on ESCALA PL 450T/R, ESCALA PL 450T/R+ or ESCALA PL 850T/R-L+, models that are not attached to an HMC.

- PFW1548-550-1a
  1. Insure that the diagnostics and the operating system(s) are shut down.
  2. Turn on the power.
  3. Insert the AIX diagnostic CD-ROM into the optical drive.

**Note:** If you cannot insert the diagnostic CD-ROM, go to [PFW1548-550-2a](#).

4. When the keyboard indicator is displayed on the system console:
  - ◇ On an ASCII terminal or directly-attached keyboard, press the number 5 key.
5. If you are prompted to do so, enter the appropriate password.

### **Is the "Please define the System Console" screen displayed?**

NO

Go to step [PFW1548-550-2a](#).

YES

Go to step [PFW1548-550-17a](#).

- PFW1548-550-2a
  1. Turn on the power.
  2. If you have not already done so, configure the service processor (using the ASMI menus) with the instructions in note 6 at the beginning of this MAP, then return here and continue.
  3. Exit the service processor (ASMI) menus and remove the power cords.
  4. Disconnect all external cables (parallel, system port 1, system port 2, keyboard, mouse, Ethernet on the system planar, Ethernet on the service processor if present, and so on).
  5. Remove the service access cover (model xxx), or place the drawer (model yyy), into the service position and remove the service access cover.
  6. Record the slot numbers of the PCI adapters. Label and record the locations of all cables attached to the adapters. Disconnect all cables attached to the adapters and remove all of the adapters.
  7. Disconnect all of the power and signal cables from the media drives located in the media bay.
  8. Remove the media drives.
  9. Remove processor card #2 (if installed). If processor card #2 is removed, insure that processor card #1 is installed and contains at least one pair of DIMMs.
  10. Record the slot numbers of the memory DIMMs on processor card #1. Remove all memory DIMMs except for one pair from processor card #1.

### **Notes:**

- a. Place the memory DIMM locking tabs in the locked (upright) position to prevent damage to the tabs.
- b. Memory DIMMs must be installed in pairs and in the correct connectors. Refer to "Memory DIMM Locations" for information on memory DIMMs.

11. Disconnect the IDE cable from the IDE connector on the system backplane.
12. If the system is equipped with a diskette drive, disconnect the diskette drive cable from the diskette drive connector on the system backplane.
13. Disconnect the signal and power connectors from both disk drive backplanes.
14. Disconnect the disk drives from both disk drive backplanes.
15. Plug in the power cords and wait for "01" in the upper-left-hand corner of the control panel display.
16. Turn on the power.

**Does the system stop with B1xxF22A, CA00E1F2, CA00E1F3, or STBY displayed on the control panel?**

NO

Go to step [PFW1548-550-6a](#).

YES

Go to step [PFW1548-550-3a](#).

- PFW1548-550-3a

**Were any memory DIMMs removed from processor card #1?**

NO

Go to step [PFW1548-550-8a](#).

YES

Go to step [PFW1548-550-4a](#).

- PFW1548-550-4a

1. Turn off the power, and remove the power cords.
2. Replug the memory DIMMs that were removed from processor card #1 in step [PFW1548-550-2a](#) in their original locations.

**Notes:**

- a. Place the memory DIMM locking tabs into the locked (upright) position to prevent damage to the tabs.
- b. Memory DIMMs must be installed in pairs in the correct connectors. Refer to "Memory DIMM Locations" for information on memory DIMMs.

3. Plug in the power cords and wait for "01" in the upper-left corner of the control panel display.
4. Turn on the power.

**Does the system stop with B1xxF22A, CA00E1F2, CA00E1F3, or STBY displayed on the control panel?**

NO

A memory DIMM in the pair you just replaced in the system is defective. Turn off the power, remove the power cords, and exchange the memory DIMMs in that pair one at a time with new or previously removed memory DIMMs. Repeat this step until the defective memory DIMM is identified, or all memory DIMMs have been exchanged.

If your symptom did not change and all the memory DIMMs have been exchanged, call your service support person for assistance.

If the symptom changed, check for loose cards and obvious problems.

If you do not find a problem, go to the [Start-of-Call MAP](#) and follow the instructions for the new symptom.

YES

Go to [PFW1548-550-5a](#).

- PFW1548-550-5a

**Was processor card #2 removed from the system?**

NO

Go to step [PFW1548-550-8a](#).

YES

Go to step [PFW1548-550-7a](#).

- PFW1548-550-6a

One of the FRUs remaining in the system unit is defective.

**Note:** If a memory DIMM is exchanged, insure that the new memory DIMM is the same size and speed as the original memory DIMM.

1. Turn off the power, remove the power cords, and exchange the following FRUs in the order listed:
  - a. Memory DIMMs. Exchange one at a time with new or previously removed DIMMs
  - b. Processor card #1
  - c. System backplane
  - d. Power supplies.
2. Plug in the power cords and wait for "01" in the upper-left corner of the control panel display.
3. Turn on the power.

**Does the system stop with B1xxF22A, CA00E1F2, CA00E1F3, or STBY displayed on the control panel?**

NO

Reinstall the original FRU. Repeat the FRU replacement steps until the defective FRU is identified or all the FRUs have been exchanged.

If the symptom did not change and all the FRUs have been exchanged, call service support for assistance.

If the symptom has changed, check for loose cards, cables, and obvious problems.

If you do not find a problem, go to the [Start-of-call procedure](#) and follow the instructions for the new symptom.

YES

Go to [MAP 0410: Repair Checkout](#).

- PFW1548-550-7a

No failure was detected with this configuration.

1. Turn off the power and remove the power cords.
2. Reinstall processor card #2.
3. Plug in the power cords and wait for "01" in the upper-left-hand corner of the operator panel display.
4. Turn on the power.

**Does the system stop with B1xxF22A, CA00E1F2, CA00E1F3, or STBY displayed on the operator panel?**

NO

One of the FRUs remaining in the system is defective.

Exchange the FRUs (that have not already been changed) in the following order:

1. Memory DIMMs (if present) on processor card #2. Exchange the DIMMs one at a time with new or previously removed DIMMs.
2. Processor card #2
3. System backplane

Repeat the FRU replacement steps until the defective FRU is identified or all the FRUs have been exchanged.

If the symptom did not change and all the FRUs have been exchanged, call service support for assistance.

If the symptom has changed, check for loose cards, cables, and obvious problems.

If you do not find a problem, go to the [Start-of-call procedure](#) and follow the instructions for the new symptom.

YES

Go to step [PFW1548-550-8a](#).

- PFW1548-550-8a

1. Turn off the power.
2. Reconnect the system console.
  - a. If an ASCII terminal has been defined as the firmware console, attach the ASCII terminal cable to the S1 connector on the rear of the system unit.
  - b. If a display attached to a display adapter has been defined as the firmware console, install the display adapter and connect the display to the adapter. Plug the keyboard and mouse into the keyboard connector on the rear of the system unit.
3. Turn on the power.
4. If the ASCII terminal or graphics display (including display adapter) is connected differently from the way it was previously, the console selection screen appears. Select a firmware console.
5. When the word keyboard is displayed, press the number 1 key on the directly attached keyboard, an ASCII terminal or HMC. This activates the system management services (SMS).
6. Enter the appropriate password if you are prompted to do so.

**Is the SMS screen displayed?**

NO

One of the FRUs remaining in the system unit is defective.

Exchange the FRUs that have not been exchanged, in the following order:

1. If you are using an ASCII terminal, go to the problem determination procedures for the display. If you do not find a problem, replace the system backplane, location Un-P1.
2. If you are using a graphics display, go to the problem determination procedures for the display.

If you do not find a problem, do the following:

- Replace the display adapter.
- Replace the backplane in which the graphics adapter is plugged.

Repeat this step until the defective FRU is identified or all the FRUs have been exchanged.

If the symptom did not change and all the FRUs have been exchanged, call service support for assistance.

If the symptom changed, check for loose cards, cables, and obvious problems.

If you do not find a problem, go to the [Start-of-call procedure](#) and follow the instructions for the new symptom.

YES

Go to [PFW1548-550-9a](#).

- PFW1548-550-9a
  1. Make sure the diagnostic CD-ROM is inserted into the optical drive.
  2. Turn off the power and remove the power cords.
  3. Plug the IDE cable into the IDE connector on the system backplane.
  4. Connect the signal and power connectors to the IDE optical drive.
  5. Plug in the power cords and wait for "01" in the upper-left corner of the control panel display.
  6. Turn on the power.
  7. Insert the diagnostic CD-ROM into the optical drive.
  8. After the word keyboard is displayed, press the number 5 key on either the directly attached keyboard or an ASCII terminal keyboard.
  9. Enter the appropriate password if you are prompted to do so.

**Is the Please define the System Console screen displayed?**

NO

One of the FRUs remaining in the system unit is defective.

Exchange the FRUs that have not been exchanged, in the following order:

1. IDE cable
2. Optical drive
3. Media backplane
4. System backplane

Repeat this step until the defective FRU is identified or all the FRUs have been exchanged.



If the symptom did not change and all the FRUs have been exchanged, call service support for assistance.

If the symptom has changed, check for loose cards, cables, and obvious problems.

If you do not find a problem, go to the [Start-of-call procedure](#) and follow the instructions for the new symptom.

YES

Go to [PFW1548-550-10a](#).

- PFW1548-550-10a

The system is working correctly with this configuration. One of the SCSI devices that was disconnected may be defective.

1. Make sure the diagnostic CD-ROM is inserted into the optical drive.
2. Turn off the power and remove the power cords.
3. Plug the SCSI cable into the SCSI connector on the system backplane.
4. Connect the signal and power connectors to one of the SCSI devices if present (a SCSI LVD tape device in media bay #1, for example). Do not connect the signal and power connectors to the disk drive backplane at this time.
5. Plug in the power cords and wait for "01" in the upper-left corner of the control panel display.
6. Turn on the power.
7. After the word keyboard is displayed, press the number 5 key on either the directly attached keyboard or on an ASCII terminal keyboard.
8. Enter the appropriate password if you are prompted to do so.

**Is the Please define the System Console screen displayed?**

NO

One of the FRUs remaining in the system unit is defective.

Exchange the FRUs that have not been exchanged, in the following order:

1. SCSI cable
2. Last SCSI device connected (for example, tape drive)
3. System backplane

Repeat this step until the defective FRU is identified or all the FRUs have been exchanged.

If the symptom did not change and all the FRUs have been exchanged, call service support for assistance.

If the symptom has changed, check for loose cards, cables, and obvious problems.

If you do not find a problem, go to the [Start-of-call procedure](#) and follow the instructions for the new symptom.

YES

Repeat this step, adding one SCSI device at a time, until all the SCSI devices that were attached to the integrated SCSI adapter, except the disk drive backplanes, are connected and tested. Go to [PFW1548-550-11a](#).

- PFW1548-550-11a

The system is working correctly with this configuration. One of the disk drive backplanes may be defective.

1. Make sure the diagnostic CD-ROM is inserted into the optical drive.
2. Turn off the power and remove the power cords.
3. Connect the signal and power connectors to one of the disk drive backplanes.
4. Plug in the power cords and wait for "01" in the upper-left corner of the control panel display.
5. Turn on the power.
6. If the Console Selection screen is displayed, choose the system console.
7. After the word keyboard is displayed, press the number 5 key on either the directly attached keyboard or an ASCII terminal keyboard.
8. Enter the appropriate password if you are prompted to do so.

**Is the Please define the System Console screen displayed?**

NO

One of the FRUs remaining in the system unit is defective.

Exchange the FRUs that have not been exchanged, in the following order:

1. SCSI cable
2. Disk drive backplane

Repeat this step until the defective FRU is identified or all the FRUs have been exchanged.

If the symptom did not change and all the FRUs have been exchanged, call service support for assistance.

If the symptom has changed, check for loose cards, cables, and obvious problems.

If you do not find a problem, go to the [Start-of-call procedure](#) and follow the instructions for the new symptom.

YES

If both disk drive backplanes have been reconnected, go to [PFW1548-550-12a](#). Otherwise, repeat PFW1548-550-11a for the other disk drive backplane if present.

• PFW1548-550-12a

The system is working correctly with this configuration. One of the disk drives that you removed from the disk drive backplanes may be defective.

1. Make sure the diagnostic CD-ROM is inserted into the optical drive.
2. Turn off the power and remove the power cords.
3. Install a disk drive in a disk drive backplane.
4. Plug in the power cords and wait for the OK prompt to display on the control panel display.
5. Turn on the power.
6. After the word keyboard is displayed, press the number 5 key on either the directly attached keyboard or an ASCII terminal keyboard.
7. Enter the appropriate password if you are prompted to do so.

**Is the Please define the System Console screen displayed?**

NO

Exchange the FRUs that have not been exchanged, in the following order:

1. Last disk drive installed
2. Disk drive backplane where the disk drive was installed

Repeat this step until the defective FRU is identified or all the FRUs have been exchanged. If the symptom did not change and all the FRUs have been exchanged, call service support for assistance.

If the symptom has changed, check for loose cards, cables, and obvious problems.

If you do not find a problem, go to the [Start-of-call procedure](#) and follow the instructions for the new symptom.

YES

Repeat this step with all disk drives that were installed in the disk drive backplanes.

If the system has a diskette drive, go to [PFW1548-550-13a](#), if not go to [PFW1548-550-14a](#).

• PFW1548-550-13a

The system is working correctly with this configuration. The diskette drive may be defective.

1. Make sure the diagnostic CD-ROM is inserted into the optical drive.
2. Turn off the power and remove the power cords.
3. Plug the diskette drive cable into the diskette drive connector on the system backplane.
4. Connect the signal and power connectors to the diskette drive.
5. Plug in the power cords and wait for "01" in the upper-left corner of the control panel display.
6. Turn on the power.
7. After the word keyboard displays, press the number 5 key on either the directly attached keyboard or on an ASCII terminal keyboard.
8. Enter the appropriate password if you are prompted to do so.

**Is the Please define the System Console screen displayed?**

NO

One of the FRUs remaining in the system is defective.

Exchange the FRUs that have not been exchanged, in the following order:

1. Diskette drive
2. Diskette drive cable
3. System backplane

Repeat this step until the defective FRU is identified or all the FRUs have been exchanged. If the symptom did not change and all the FRUs have been exchanged, call service support for assistance.

If the symptom has changed, check for loose cards, cables, and obvious problems.

If you do not find a problem return, go to the [Start-of-call procedure](#) and follow the instructions for the new symptom.

YES

Go to [PFW1548-550-14a](#).

- PFW1548-550-14a

The system is working correctly with this configuration. One of the devices that was disconnected from the system backplane may be defective.

1. Turn off the power and remove the power cords.
2. Attach a system backplane device (for example: parallel, system port 1, system port 2, system port 3, keyboard, mouse, Ethernet, Ultra-2 SCSI, keyboard or mouse) that had been removed.
3. Plug in the power cords and wait for "01" in the upper-left corner on the control panel display.
4. Turn on the power.
5. If the Console Selection screen is displayed, choose the system console.
6. After the word keyboard displays, press the number 5 key on either the directly attached keyboard or on an ASCII terminal keyboard.
7. Enter the appropriate password if you are prompted to do so.

**Is the Please define the System Console screen displayed?**

NO

The last device or cable that you attached is defective.

To test each FRU, exchange the FRUs in the following order:

1. Device and cable (last one attached)
2. System backplane

Repeat this step until the defective FRU is identified or all the FRUs have been exchanged. If the symptom did not change and all the FRUs have been exchanged, call service support for assistance.

If the symptom has changed, check for loose cards, cables, and obvious problems.

If you do not find a problem return, go to the [Start-of-call procedure](#) and follow the instructions for the new symptom.

Go to [MAP 0410: Repair Checkout](#).

YES

Repeat this step until all of the devices are attached. Go to [PFW1548-550-15a](#).

- PFW1548-550-15a

The system is working correctly with this configuration. One of the FRUs (adapters) that you removed may be defective.

1. Turn off the power and remove the power cords.
2. Install a FRU (adapter) and connect any cables and devices that were attached to the FRU.
3. Plug in the power cords and wait for the OK prompt to display on the control panel display.
4. Turn on the power.
5. If the Console Selection screen is displayed, choose the system console.
6. After the word keyboard displays, press the number 5 key on either the directly attached keyboard or on an ASCII terminal keyboard.
7. Enter the appropriate password if you are prompted to do so.

**Is the Please define the System Console screen displayed?**

NO

Go to [PFW1548-550-16a](#).

YES

Repeat this step until all of the FRUs (adapters) are installed. Go to [MAP 0410: Repair Checkout](#).

- PFW1548-550-16a

The last FRU installed or one of its attached devices is probably defective.

1. Make sure the diagnostic CD-ROM is inserted into the optical drive.
2. Turn off the power and remove the power cords.
3. Starting with the last installed adapter, disconnect one attached device and cable.
4. Plug in the power cords and wait for the "01" in the upper-left corner on the control panel display.
5. Turn on the power.
6. If the Console Selection screen is displayed, choose the system console.
7. After the word keyboard displays, press the number 5 key on either the directly attached keyboard or on an ASCII terminal keyboard.
8. Enter the appropriate password if you are prompted to do so.

**Is the Please define the System Console screen displayed?**

NO

Repeat this step until the defective device or cable is identified or all devices and cables have been disconnected.

If all the devices and cables have been removed, then one of the FRUs remaining in the system unit is defective.

To test each FRU, exchange the FRUs in the following order:

1. Adapter (last one installed)
2. System backplane

If the symptom did not change and all the FRUs have been exchanged, call service support for assistance.

If the symptom has changed, check for loose cards, cables, and obvious problems.

If you do not find a problem, go to the [Start-of-call procedure](#) and follow the instructions for the new symptom.

YES

The last device or cable that you disconnected is defective. Exchange the defective device or cable. Go to [MAP 0410: Repair Checkout](#).

- PFW1548-550-17a

1. Follow the instructions on the screen to select the system console.
2. When the DIAGNOSTIC OPERATING INSTRUCTIONS screen is displayed, press Enter.
3. Select Advanced Diagnostics Routines.
4. If the terminal type has not been defined, you must use the initialize terminal option on the FUNCTION SELECTION menu to initialize the AIX diagnostic environment before you can continue with the diagnostics. This is a separate operation from selecting the console display.
5. If the NEW RESOURCE screen is displayed, select an option from the bottom of the screen.

**Note:** Adapters and devices that require supplemental media are not shown in the new resource list. If the system has adapters or devices that require supplemental media, select option 1.

6. When the DIAGNOSTIC MODE SELECTION screen is displayed, press Enter.
7. Select All Resources. (If you were sent here from [PFW1548-550-21a](#), select the adapter or device that was loaded from the supplemental media).

Did you get an SRN?

NO

Go to [PFW1548-550-19a](#).

YES

Go to [PFW1548-550-18a](#).

- PFW1548-550-18a

Look at the FRU part numbers associated with the SRN.

**Have you exchanged all the FRUs that correspond to the failing function codes (FFCs)?**

NO

Exchange the FRU with the highest failure percentage that has not been changed.

Repeat this step until all the FRUs associated with the SRN have been exchanged or diagnostics run with no trouble found. Run diagnostics after each FRU is exchanged. Go to [MAP 0410: Repair Checkout](#).

YES

If the symptom did not change and all the FRUs have been exchanged, call service support for assistance.

- PFW1548-550-19a

**Does the system have adapters or devices that require supplemental media?**

NO

Go to [PFW1548-550-20a](#).

YES

Go to [PFW1548-550-21a](#).

- PFW1548-550-20a

Consult the PCI adapter configuration documentation for your operating system to verify that all adapters are configured correctly. Go to [MAP 0410: Repair Checkout](#).

If the symptom did not change and all the FRUs have been exchanged, call service support for assistance.

- PFW1548-550-21a

1. Select Task Selection.

2. Select Process Supplemental Media and follow the on screen instructions to process the media. Supplemental media must be loaded and processed one at a time.

**Did the system return to the TASKS SELECTION SCREEN after the supplemental media was processed?**

NO

Go to [PFW1548-550-22a](#).

YES

Press F3 to return to the FUNCTION SELECTION screen. Go to [step 4](#).

- PFW1548-550-22a

The adapter or device is probably defective.

If the supplemental media is for an adapter, replace the FRUs in the following order:

1. Adapter

2. System backplane

If the supplemental media is for a device, replace the FRUs in the following order:

1. Device and any associated cables

2. The adapter to which the device is attached

Repeat this step until the defective FRU is identified or all the FRUs have been exchanged.

If the symptom did not change and all the FRUs have been exchanged, call service support for assistance.

If the symptom has changed, check for loose cards, cables, and obvious problems.

If you do not find a problem, go to the [Start-of-call procedure](#) and follow the instructions for the new symptom. Go to [MAP 0410: Repair Checkout](#).

End of procedure.

---

## **PFW1548-570: Processor subsystem problem isolation procedure for models ESCALA PL 1650R-L+ and ESCALA PL 850R/PL 1650R/R+**

Use this problem isolation procedure to aid in solving memory and processor problems on 5/75 models.

- PFW1548-570-1

1. Insure that the diagnostics and the operating system are shut down.

**Is the system at "service processor standby", indicated by "01" in the control panel?**

NO

Replace the service processor card, location: Un-P1-C8. Return to step [PFW1548-570-1](#).

YES

Continue with substep 2.

2. Turn on the power using either the white button or the HMC.

**Does the managed system reach power on at hypervisor standby as indicated on the HMC?**

NO

Go to [PFW1548-570-3](#).

YES

Go to [PFW1548-570-2](#).

3. Insert the AIX diagnostic CD-ROM into the optical drive.

**Note:** If you cannot insert the diagnostic CD-ROM, go to [PFW1548-570-2](#).

4. When the keyboard indicator is displayed on an ASCII terminal, a directly-attached keyboard, or hardware management console (HMC), press the number 5 key.
5. If you are prompted to do so, enter the appropriate password.

**Is the Please define the System Console screen displayed?**

NO

Go to [PFW1548-570-2](#).

YES

Go to [PFW1548-570-17](#).

- PFW1548-570-2

Insert the AIX diagnostic CD-ROM into the optical drive.

**Note:** If you cannot insert the diagnostic CD-ROM, go to step [PFW1548-570-3](#).

Turn on the power using either the HMC or the white button. (If the diagnostic CD-ROM is not in the optical drive, insert it now.) After the system has reached hypervisor standby, activate a Linux or AIX partition by clicking on the "Advanced" button on the activation screen. On the "advanced" activation screen, select "boot in service mode using the default boot list" to boot the diagnostic CD-ROM.

If you are prompted to do so, enter the appropriate password.

**Is the "Please define the System Console" screen displayed?**

NO

Go to [PFW1548-570-3](#).

YES

Go to [PFW1548-570-24](#).

- PFW1548-570-3

1. Turn off the power.
2. If you have not already done so, configure the service processor (using the ASMI menus) with the instructions in note 6 at the beginning of this procedure, then return here and continue.
3. Exit the service processor (ASMI) menus and remove the power cords.
4. Disconnect all external cables (parallel, system port 1, system port 2, keyboard, mouse, USB devices, SPCN, Ethernet on the system planar, and so on). Also disconnect all of the external cables attached to the service processor except the Ethernet cable going to the HMC.

**Is there more than one processor drawer in the system?**

NO

Go to [PFW 1548-570-5](#).

YES

Go to [PFW1548-570-4](#).

• PFW1548-570-4

Disconnect the flex cables from the front and the back of the all processor drawers if not already disconnected.

**Does the processor drawer with the service processor card power on OK?**

NO

Go to [PFW 1548-570-5](#).

YES

Go to [PFW1548-570-20](#).

• PFW1548-570-5

1. Place the drawer into the service position and remove the service access cover.
2. Record the slot numbers of the PCI adapters. Label and record the locations of all cables attached to the adapters. Disconnect all cables attached to the adapters and remove all of the adapters.
3. Disconnect all of the power and signal cables from the media drives located in the media bay.
4. Remove the media drives.
5. Remove processor card #2 (if installed). If processor card #2 is removed, insure that processor card #1 is installed and contains at least one quad of DIMMs.
6. Record the slot numbers of the memory DIMMs on processor card #1. Remove all memory DIMMs except for one quad from processor card #1.

**Notes:**

- a. Place the memory DIMM locking tabs in the locked (upright) position to prevent damage to the tabs.
- b. Memory DIMMs must be installed in quads and in the correct connectors. Refer to [Memory DIMM locations](#) for information on memory DIMMs.

7. Disconnect the IDE cable from the IDE connector on the system backplane.
8. Disconnect the signal and power connectors from the disk drive backplane.
9. Disconnect the disk drives from the disk drive backplane.
10. Plug in the power cords and wait for "01" in the upper-left-hand corner of the control panel display.
11. Turn on the power using either the HMC or the white button.

**Does the managed system reach power on at hypervisor standby as indicated on the HMC?**

NO

Go to [PFW1548-570-9](#).

YES

Go to [PFW1548-570-6](#).

• PFW1548-570-6

**Were any memory DIMMs removed from processor card #1?**

NO

Go to [PFW1548-570-11](#).

YES

Go to [PFW1548-570-7](#).

• PFW1548-570-7

1. Turn off the power, and remove the power cords.
2. Replug the memory DIMMs that were removed from processor card #1 in [PFW1548-570-2](#) in their original locations.

**Notes:**

- a. Place the memory DIMM locking tabs into the locked (upright) position to prevent damage to the tabs.
  - b. Memory DIMMs must be installed in quads in the correct connectors. Refer to [Memory DIMM locations](#) for information on memory DIMMs.
3. Plug in the power cords and wait for "01" in the upper-left corner of the control panel display.
  4. Turn on the power using either the HMC or the white button.

**Does the managed system reach power on at hypervisor standby as indicated on the HMC?**

NO

A memory DIMM in the quad you just replaced in the system is defective. Turn off the power, remove the power cords, and exchange the memory DIMMs in that quad one at a time with new or previously removed memory DIMMs. Repeat this step until the defective memory DIMM is identified, or all memory DIMMs have been exchanged.

If your symptom did not change and all the memory DIMMs have been exchanged, call your service support person for assistance.

If the symptom changed, check for loose cards and obvious problems. If you do not find a problem, go to the [Start-of-call procedure](#) and follow the instructions for the new symptom.

YES

Go to [PFW1548-570-8](#).

- PFW1548-570-8

**Was processor card #2 removed from the system?**

NO

Go to [PFW1548-570-10](#).

YES

Go to [PFW1548-570-9](#).

- PFW1548-570-9

One of the FRUs remaining in the system unit is defective.

**Note:** If a memory DIMM is exchanged, insure that the new memory DIMM is the same size and speed as the original memory DIMM.

1. Turn off the power, remove the power cords, and exchange the following FRUs in the order listed:
  - a. Memory DIMMs. Exchange one at a time with new or previously removed DIMMs
  - b. Processor card #1, location: Un-P2-C1.
  - c. Processor backplane, location: Un-P2
  - d. Power supplies, locations: Un-E1 and Un-E2.
  - e. Processor regulators, locations: Un-P2-C3, Un-P2-C4, Un-P2-C5.
  - f. Service processor, location: Un-P1-C8.
  - g. I/O backplane, location: Un-P1.
2. Plug in the power cords and wait for "01" in the upper-left corner of the control panel display.
3. Turn on the power using either the HMC or the white button.

**Does the managed system reach power on at hypervisor standby as indicated on the HMC?**

NO

Reinstall the original FRU.

Repeat the FRU replacement steps until the defective FRU is identified or all the FRUs have been exchanged.

If the symptom did not change and all the FRUs have been exchanged, call service support for assistance.

If the symptom has changed, check for loose cards, cables, and obvious problems. If you do not find a problem, go to the [Start-of-call procedure](#) and follow the instructions for the new symptom.

YES



Go to [MAP 0410: Repair Checkout](#).

- PFW1548-570-10

No failure was detected with this configuration.

1. Turn off the power and remove the power cords.
2. Reinstall processor card #2.
3. Plug in the power cords and wait for "01" in the upper-left corner of the control panel display.
4. Turn on the power using either the HMC or the white button.

**Does the managed system reach power on at hypervisor standby as indicated on the HMC?**

NO

One of the FRUs remaining in the system is defective.

Exchange the FRUs (that have not already been changed) in the following order:

1. Memory DIMMs (if present) on processor card #2. Exchange the DIMMs one at a time with new or previously removed DIMMs.
2. Processor card #2
3. Processor backplane, location: Un-P2.
4. Power supplies, locations: Un-E1 and Un-E2.
5. Processor regulators, locations: Un-P2-C3, Un-P2-C4, Un-P2-C5.
6. Service processor, location: Un-P1-C8.
7. I/O backplane, location: Un-P1.

Repeat the FRU replacement steps until the defective FRU is identified or all the FRUs have been exchanged.

If the symptom did not change and all the FRUs have been exchanged, call service support for assistance.

If the symptom has changed, check for loose cards, cables, and obvious problems. If you do not find a problem, go to the [Start-of-call procedure](#) and follow the instructions for the new symptom.

YES

Go to [PFW1548-570-11](#).

- PFW1548-570-11

1. Turn off the power.
2. Reconnect the system console.

#### Notes:

- a. If an ASCII terminal has been defined as the firmware console, attach the ASCII terminal cable to the S1 connector on the rear of the system unit.
  - b. If a display attached to a display adapter has been defined as the firmware console, install the display adapter and connect the display to the adapter. Plug the keyboard and mouse into the keyboard connector on the rear of the system unit.
3. Turn on the power using either the HMC or the white button. (If the diagnostic CD-ROM is not in the optical drive, insert it now.) After the system has reached hypervisor standby, activate a Linux or AIX partition by clicking on the "Advanced" button on the activation screen. On the "advanced" activation screen, select "boot in service mode using the default boot list" to boot the diagnostic CD-ROM.
  4. If the ASCII terminal or graphics display (including display adapter) is connected differently from the way it was previously, the console selection screen appears. Select a firmware console.
  5. When the word keyboard is displayed, press the number 1 key on the directly attached keyboard, an ASCII terminal or HMC. This activates the system management services (SMS).
  6. Enter the appropriate password if you are prompted to do so.

**Is the SMS screen displayed?**

NO

One of the FRUs remaining in the system unit is defective.

Exchange the FRUs that have not been exchanged, in the following order:

1. If you are using an ASCII terminal, go to the problem determination procedures for the display. If you do not find a problem, do the following:
  - a. Replace the service processor, location: Un-P1-C8.
  - b. Replace the I/O backplane, location: Un-P1.
2. If you are using a graphics display, go to the problem determination procedures for the display. If you do not find a problem, do the following:
  - a. Replace the display adapter.
  - b. Replace the backplane in which the graphics adapter is plugged.

Repeat this step until the defective FRU is identified or all the FRUs have been exchanged.

If the symptom did not change and all the FRUs have been exchanged, call service support for assistance.

If the symptom changed, check for loose cards, cables, and obvious problems. If you do not find a problem, go to the [Start-of-call procedure](#) and follow the instructions for the new symptom.

YES

Go to [PFW1548-570-12](#).

• PFW1548-570-12

1. Make sure the diagnostic CD-ROM is inserted into the optical drive.
2. Turn off the power and remove the power cords.
3. Plug the IDE cable into the IDE connector on the system backplane.
4. Connect the signal and power connectors to the IDE optical drive.
5. Plug in the power cords and wait for "01" in the upper-left corner of the operator panel display.
6. Turn on the power using either the HMC or the white button. (If the diagnostic CD-ROM is not in the optical drive, insert it now.) After the system has reached hypervisor standby, activate a Linux or AIX partition by clicking on the "Advanced" button on the activation screen. On the "advanced" activation screen, select "boot in service mode using the default boot list" to boot the diagnostic CD-ROM.
7. Insert the diagnostic CD-ROM into the optical drive.
8. After the word keyboard is displayed, press the number 5 key on either the directly attached keyboard or an ASCII terminal keyboard.
9. Enter the appropriate password if you are prompted to do so.

**Is the Please define the System Console screen displayed?**

NO

One of the FRUs remaining in the system unit is defective.

Exchange the FRUs that have not been exchanged, in the following order:

1. IDE cable
2. Optical drive
3. Media backplane, Un-P3.
4. I/O backplane, Un-P1.

Repeat this step until the defective FRU is identified or all the FRUs have been exchanged.

If the symptom did not change and all the FRUs have been exchanged, call service support for assistance.

If the symptom has changed, check for loose cards, cables, and obvious problems. If you do not find a problem, go to the [Start-of-call procedure](#) and follow the instructions for the new symptom.

YES

Go to [PFW1548-570-13](#).

• PFW1548-570-13

The system is working correctly with this configuration. One of the SCSI devices that was disconnected may be defective.

1. Make sure the diagnostic CD-ROM is inserted into the optical drive.
2. Turn off the power and remove the power cords.
3. Plug the SCSI cable into the SCSI connector on the system backplane.
4. Connect the signal and power connectors to one of the SCSI devices if present (a SCSI LVD tape device in media bay #1, for example). Do not connect the signal and power connectors

to the disk drive backplane at this time.

5. Plug in the power cords and wait for "01" in the upper-left corner of the operator panel display.
6. Turn on the power using either the HMC or the white button. (If the diagnostic CD-ROM is not in the optical drive, insert it now.) After the system has reached hypervisor standby, activate a Linux or AIX partition by clicking on the "Advanced" button on the activation screen. On the "advanced" activation screen, select "boot in service mode using the default boot list" to boot the diagnostic CD-ROM.
7. After the word keyboard is displayed, press the number 5 key on either the directly attached keyboard or on an ASCII terminal keyboard.
8. Enter the appropriate password if you are prompted to do so.

**Is the Please define the System Console screen displayed?**

NO

One of the FRUs remaining in the system unit is defective.

Exchange the FRUs that have not been exchanged, in the following order:

1. SCSI cable
2. Last SCSI device connected (for example, tape drive)
3. I/O backplane, location: Un-P1.

Repeat this step until the defective FRU is identified or all the FRUs have been exchanged.

If the symptom did not change and all the FRUs have been exchanged, call service support for assistance.

If the symptom has changed, check for loose cards, cables, and obvious problems. If you do not find a problem, go to the [Start-of-call procedure](#) and follow the instructions for the new symptom.

YES

Repeat this step, adding one SCSI device at a time, until all the SCSI devices that were attached to the integrated SCSI adapter, except the disk drive backplanes, are connected and tested. Go to [PFW1548-570-14](#).

- PFW1548-570-14

The system is working correctly with this configuration. One of the disk drive backplanes may be defective.

1. Make sure the diagnostic CD-ROM is inserted into the optical drive.
2. Turn off the power and remove the power cords.
3. Connect the signal and power connectors to the disk drive backplane.
4. Plug in the power cords and wait for "01" in the upper-left corner of the operator panel display.
5. Turn on the power using either the HMC or the white button. (If the diagnostic CD-ROM is not in the optical drive, insert it now.) After the system has reached hypervisor standby, activate a Linux or AIX partition by clicking on the "Advanced" button on the activation screen. On the "advanced" activation screen, select "boot in service mode using the default boot list" to boot the diagnostic CD-ROM.
6. If the Console Selection screen is displayed, choose the system console.
7. After the word keyboard is displayed, press the number 5 key on either the directly attached keyboard or an ASCII terminal keyboard.
8. Enter the appropriate password if you are prompted to do so.

**Is the Please define the System Console screen displayed?**

NO

One of the FRUs remaining in the system unit is defective.

Exchange the FRUs that have not been exchanged, in the following order:

1. SCSI cable
2. SCSI backplane, location: Un-P3.
3. I/O backplane, location: Un-P1.

Repeat this step until the defective FRU is identified or all the FRUs have been exchanged.

If the symptom did not change and all the FRUs have been exchanged, call service support for assistance.

If the symptom has changed, check for loose cards, cables, and obvious problems. If you do not find a problem, go to the [Start-of-call procedure](#) and follow the instructions for the new symptom.

YES

If both disk drive backplanes have been reconnected, go to [PFW1548-570-13](#). Otherwise, repeat [PFW1548-570-12](#) for the other disk drive backplane if present.

- PFW1548-570-15

The system is working correctly with this configuration. One of the disk drives that you removed from the disk drive backplanes may be defective.

1. Make sure the diagnostic CD-ROM is inserted into the optical drive.
2. Turn off the power and remove the power cords.
3. Install a disk drive in a disk drive backplane.
4. Plug in the power cords and wait for the OK prompt to display on the operator panel display.
5. Turn on the power.
6. After the word keyboard is displayed, press the number 5 key on either the directly attached keyboard or an ASCII terminal keyboard.
7. Enter the appropriate password if you are prompted to do so.

**Is the Please define the System Console screen displayed?**

NO

Exchange the FRUs that have not been exchanged, in the following order:

1. Last disk drive installed
2. Disk drive backplane where the disk drive was installed

Repeat this step until the defective FRU is identified or all the FRUs have been exchanged.

If the symptom did not change and all the FRUs have been exchanged, call service support for assistance.

If the symptom has changed, check for loose cards, cables, and obvious problems. If you do not find a problem, go to the [Start-of-call procedure](#) and follow the instructions for the new symptom.

YES

Repeat this step with all disk drives that were installed in the disk drive backplanes.

If the system has an internal diskette drive, go to [PFW1548-570-14](#), if not go to [PFW1548-570-15](#).

- PFW1548-570-16

The system is working correctly with this configuration. The diskette drive may be defective.

1. Make sure the diagnostic CD-ROM is inserted into the optical drive.
2. Turn off the power and remove the power cords.
3. Plug the diskette drive cable into the diskette drive connector on the system backplane.
4. Connect the signal and power connectors to the diskette drive.
5. Plug in the power cords and wait for "01" in the upper-left corner of the operator panel display.
6. Turn on the power using either the HMC or the white button. (If the diagnostic CD-ROM is not in the optical drive, insert it now.) After the system has reached hypervisor standby, activate a Linux or AIX partition by clicking on the "Advanced" button on the activation screen. On the "advanced" activation screen, select "boot in service mode using the default boot list" to boot the diagnostic CD-ROM.
7. After the word keyboard displays, press the number 5 key on either the directly attached keyboard or on an ASCII terminal keyboard.
8. Enter the appropriate password if you are prompted to do so.

**Is the Please define the System Console screen displayed?**

NO

One of the FRUs remaining in the system is defective.

Exchange the FRUs that have not been exchanged, in the following order:

1. Diskette drive
2. Diskette drive cable
3. System backplane

Repeat this step until the defective FRU is identified or all the FRUs have been exchanged. If the symptom did not change and all the FRUs have been exchanged, call service support for assistance.

If the symptom has changed, check for loose cards, cables, and obvious problems. If you do not find a problem return, go to the [Start-of-call procedure](#) and follow the instructions for the new symptom.

YES

Go to [PFW1548-570-17](#).

- PFW1548-570-17

The system is working correctly with this configuration. One of the devices that was disconnected from the system backplane may be defective.

1. Turn off the power and remove the power cords.
2. Attach a system backplane device (for example: system port 1, system port 2, USB, keyboard, mouse, Ethernet, SCSI) that had been removed.

After all of the I/O backplane device cables have been reattached, reattached the cables to the service processor one at a time.

3. Plug in the power cords and wait for "01" in the upper-left corner on the operator panel display.
4. Turn on the power using either the HMC or the white button. (If the diagnostic CD-ROM is not in the optical drive, insert it now.) After the system has reached hypervisor standby, activate a Linux or AIX partition by clicking on the "Advanced" button on the activation screen. On the "advanced" activation screen, select "boot in service mode using the default boot list" to boot the diagnostic CD-ROM.
5. If the Console Selection screen is displayed, choose the system console.
6. After the word keyboard displays, press the number 5 key on either the directly attached keyboard or on an ASCII terminal keyboard.
7. Enter the appropriate password if you are prompted to do so.

**Is the Please define the System Console screen displayed?**

NO

The last device or cable that you attached is defective.

To test each FRU, exchange the FRUs in the following order:

1. Device and cable (last one attached)
2. If the last cable in this step was reconnected to the service processor, replace the service processor.
3. I/O backplane, location: Un-P1.

If the symptom did not change and all the FRUs have been exchanged, call service support for assistance.

If the symptom has changed, check for loose cards, cables, and obvious problems. If you do not find a problem, go to the [Start-of-call procedure](#) and follow the instructions for the new symptom.

YES

Repeat this step until all of the devices are attached. Go to [PFW1548-570-18](#).

- PFW1548-570-18

The system is working correctly with this configuration. One of the FRUs (adapters) that you removed may be defective.

1. Turn off the power and remove the power cords.
2. Install a FRU (adapter) and connect any cables and devices that were attached to the FRU.
3. Plug in the power cords and wait for the OK prompt to display on the operator panel display.
4. Turn on the power using either the HMC or the white button. (If the diagnostic CD-ROM is not in the optical drive, insert it now.) After the system has reached hypervisor standby, activate a Linux or AIX partition by clicking on the "Advanced" button on the activation screen. On the "advanced" activation screen, select "boot in service mode using the default boot list" to boot the diagnostic CD-ROM.
5. If the Console Selection screen is displayed, choose the system console.
6. After the word keyboard displays, press the number 5 key on either the directly attached keyboard or on an ASCII terminal keyboard.
7. Enter the appropriate password if you are prompted to do so.

**Is the Please define the System Console screen displayed?**

NO

Go to [PFW1548-570-19](#).

YES

Repeat this step until all of the FRUs (adapters) are installed. Go to [MAP 0410: Repair Checkout](#).

- PFW1548-570-19

The last FRU installed or one of its attached devices is probably defective.

1. Make sure the diagnostic CD-ROM is inserted into the optical drive.
2. Turn off the power and remove the power cords.
3. Starting with the last installed adapter, disconnect one attached device and cable.
4. Plug in the power cords and wait for the "01" in the upper-left corner on the operator panel display.
5. Turn on the power using either the HMC or the white button. (If the diagnostic CD-ROM is not in the optical drive, insert it now.) After the system has reached hypervisor standby, activate a Linux or AIX partition by clicking on the "Advanced" button on the activation screen. On the "advanced" activation screen, select "boot in service mode using the default boot list" to boot the diagnostic CD-ROM.
6. If the Console Selection screen is displayed, choose the system console.
7. After the word keyboard displays, press the number 5 key on either the directly attached keyboard or on an ASCII terminal keyboard.
8. Enter the appropriate password if you are prompted to do so.

**Is the Please define the System Console screen displayed?**

NO

Repeat this step until the defective device or cable is identified or all devices and cables have been disconnected.

If all the devices and cables have been removed, then one of the FRUs remaining in the system unit is defective.

To test each FRU, exchange the FRUs in the following order:

1. Adapter (last one installed)
2. I/O backplane, location: Un-P1.

If the symptom did not change and all the FRUs have been exchanged, call service support for assistance.

If the symptom has changed, check for loose cards, cables, and obvious problems. If you do not find a problem, go to the [Start-of-call procedure](#) and follow the instructions for the new symptom.

YES

The last device or cable that you disconnected is defective. Exchange the defective device or cable then go to [PFW1548-570-20](#).

- PFW1548-570-20

Reattach the flex cables, if present, both front and back. Return the system to its original configuration. Reinstall the control panel, the anchor card, and the FSP in the original primary processor drawer. Reattach the power codes. Power on the system.

**Does the system come up properly?**

NO

Go to [PFW1548-570-21](#).

YES

Go to [MAP 0410: Repair Checkout](#).

- PFW1548-570-21

**Have all of the drawers been tested individually with the physical control panel (if present), FSP, and anchor card?**

NO

1. Detach the flex cables from the front and back of the system if not already disconnected.

2. Remove the service processor card, the VPD card, and the control panel from the processor drawer that was just tested.
3. Install these parts in the next drawer in the rack, going top to bottom.
4. Go to step [PFW1548-570-3](#).

YES

Reinstall the control panel, the anchor card, and the service processor card in the original primary processor drawer. Return the system to its original configuration.

Suspect a problem with the flex cables. If the error code indicates a problem with the SPCN or service processor communication between drawers, replace the flex cable in the rear. If the error code indicates a problem with inter-processor drawer communication, replace the flex cable on the front of the system.

#### **Did replacing the flex cable(s) resolve the problem?**

NO

Go to step [PFW1548-570-23](#).

YES

The problem is resolved. Go to [MAP 0410: Repair Checkout](#).

- PFW1548-570-22

This step is reserved.

- PFW1548-570-23

Replacing the flex cables did not resolve the problem. If the problem appears to be with the FSP or SPCN signals, suspect the I/O backplanes. If the problem appears to be with processor communication, suspect the processor cards.

Replace the I/O backplanes, or processor cards, one at a time until the defective part is found.

#### **Did this resolve the problem?**

NO

Contact your next level of support.

YES

The problem is resolved. Go to [MAP 0410: Repair Checkout](#).

- PFW1548-570-24

1. Follow the instructions on the screen to select the system console.
2. When the DIAGNOSTIC OPERATING INSTRUCTIONS screen is displayed, press Enter.
3. Select Advanced Diagnostics Routines.
4. If the terminal type has not been defined, you must use the initialize terminal option on the FUNCTION SELECTION menu to initialize the AIX diagnostic environment before you can continue with the diagnostics. This is a separate operation from selecting the console display.
5. If the NEW RESOURCE screen is displayed, select an option from the bottom of the screen.

**Note:** Adapters and devices that require supplemental media are not shown in the new resource list. If the system has adapters or devices that require supplemental media, select option 1.

6. When the DIAGNOSTIC MODE SELECTION screen is displayed, press Enter.
7. Select All Resources. (If you were sent here from step 1548-25, select the adapter or device that was loaded from the supplemental media).

#### **Did you get an SRN?**

NO

Go to step [PFW1548-570-26](#).

YES

Go to step [PFW1548-570-25](#).

- PFW1548-570-25

Look at the FRU part numbers associated with the SRN.

#### **Have you exchanged all the FRUs that correspond to the failing function codes (FFCs)?**

NO

Exchange the FRU with the highest failure percentage that has not been changed.

Repeat this step until all the FRUs associated with the SRN have been exchanged or diagnostics run with no trouble found. Run diagnostics after each FRU is exchanged. Go to [MAP 0410: Repair Checkout](#).

YES

If the symptom did not change and all the FRUs have been exchanged, call service support for assistance.

- PFW1548-570-26

**Does the system have adapters or devices that require supplemental media?**

NO

Go to step [PFW1548-570-27](#).

YES

Go to step [PFW1548-570-28](#).

- PFW1548-570-27

Consult the PCI adapter configuration documentation for your operating system to verify that all adapters are configured correctly.

Go to [MAP 0410: Repair Checkout](#).

If the symptom did not change and all the FRUs have been exchanged, call service support for assistance.

- PFW1548-570-28

1. Select Task Selection.

2. Select Process Supplemental Media and follow the on-screen instructions to process the media. Supplemental media must be loaded and processed one at a time.

**Did the system return to the TASKS SELECTION SCREEN after the supplemental media was processed?**

NO

Go to step [PFW1548-570-29](#).

YES

Press F3 to return to the FUNCTION SELECTION screen. Go to step [PFW1548-570-24](#), substep 4.

- PFW1548-570-29

The adapter or device is probably defective.

If the supplemental media is for an adapter, replace the FRUs in the following order:

1. Adapter
2. I/O backplane, location: Un-P1.

If the supplemental media is for a device, replace the FRUs in the following order:

1. Device and any associated cables
2. The adapter to which the device is attached

Repeat this step until the defective FRU is identified or all the FRUs have been exchanged.

If the symptom did not change and all the FRUs have been exchanged, call service support for assistance.

If the symptom has changed, check for loose cards, cables, and obvious problems. If you do not find a problem, go to the [Start-of-call procedure](#) and follow the instructions for the new symptom.

Go to [MAP 0410: Repair Checkout](#).

End of procedure.

---

## **PFW1548-575: Processor subsystem problem isolation procedure for model 5/75**

Use this problem isolation procedure to aid in solving memory and processor problems on 5/75 models.



- PFW1548-575-1

Record the error code and the location code(s) that sent you to this MAP.

**Note:** When you are directed to turn power off or turn power on in this procedure, follow the instructions in [Powering the System On and Off](#).

- PFW1548-575-2

Turn off the power. Examine the green power-in LED on the processor subsystem DCA.

- PFW1548-575-3

Is the green power-in LED on the processor subsystem DCA off?

NO

Call for service support.

YES

Go to [PFW1548-575-4](#).

- PFW1548-575-4

Replace the following cards and modules, if present, one at a time:

- ◆ First location code item recorded, if any, in PFW1548-575-1.
- ◆ Second location code item recorded, if any, in PFW1548-575-1.
- ◆ Third location code item recorded, if any, in PFW1548-575-1.

- PFW1548-575-5

Turn on the power.

**Did the system stop with the same error code as recorded in PFW1548-575-1?**

NO

The card or module just replaced was defective. This ends the procedure. Return the system to its original configuration. Go to [MAP 0410: Repair Checkout](#).

YES

Go to [PFW1548-575-6](#).

- PFW1548-575-6

**Have all the cards or modules listed in PFW1548-575-4 been replaced?**

NO

Go to [PFW1548-575-2](#).

YES

Go to [PFW1548-575-7](#).

- PFW1548-575-7

Turn off the power. Remove all but one of the quads of DIMMs plugged into the system planar. (Leave 4 DIMMs in the first 4 slots associated with one processor.)

- PFW1548-575-8

Turn on the power.

**Did the system stop with the same error code as recorded in PFW1548-575-1?**

NO

If there are more DIMMs that have not been reinstalled, turn off the power, reinstall another quad of DIMMs, then go to [PFW1548-575-9](#).

If all of the DIMMs have been reinstalled, go to [PFW1548-575-11](#).

YES

Go to [PFW1548-575-9](#).

- PFW1548-575-9

Replace the remaining quad of DIMMs one DIMM at a time. After each DIMM is replaced, turn on the power.

**Did the system stop with the same error code as recorded in PFW1548-575-1?**

NO

The DIMM you replaced was defective. Return the system to its original configuration, then go to [MAP 0410: Repair Checkout](#).

YES

**Have all 4 DIMMs in the remaining quad been replaced?**

NO

Go to [PFW1548-575-9](#).

YES

Go to [PFW1548-575-10](#).

NO

Call for service support.

- PFW1548-575-10

**Attention:** Before replacing the system backplane, call for service support.

- PFW1548-575-11

Turn on the power.

- PFW1548-575-12

**Did the system stop with the same error code as recorded in PFW1548-575-1?**

NO

The part just replaced was defective. This ends the procedure. Return the system to its original configuration. Go to [MAP 0410: Repair Checkout](#).

YES

Go to [PFW1548-575-13](#).

- PFW1548-575-13

Turn off the power. Insure that the green power-in LED on the processor subsystem DCA is off. Go to [PFW1548-575-14](#).

- PFW1548-575-14

Call for service support. This ends the procedure.

---

## Problems with noncritical resources

Use this procedure to help you determine the cause of problems with noncritical resources.

1. Is there an SRC in an 8-character format available on the Problem Summary form?

**Note:** If the operator has not filled out the problem summary form, go to the problem reporting procedure for the operating system in use.

- ◆ No: Continue with the next step.
  - ◆ Yes: Go to the [Reference codes](#) topic. This ends the procedure.
2. Does the problem involve a workstation resource?
    - ◆ No: Continue with the next step.
    - ◆ Yes: Perform the following steps:
      - ◇ Check that the workstation is operational.
      - ◇ Verify that the cabling and addressing for the workstation is correct.
      - ◇ Perform any actions indicated in the system operator message.

If you need further assistance, contact your next level of support. This ends the procedure.

3. Does the problem involve a removable media resource?
  - ◆ No: Continue with the next step.
  - ◆ Yes: Go to [Using the product activity log](#) to resolve the problem. This ends the procedure.
4. Does the problem involve a communications resource?
  - ◆ No: Contact your next level of support. This ends the procedure.
  - ◆ Yes: Are there any system operator messages that indicate a communications-related problem has occurred?
    - ◇ No: Contact your next level of support. This ends the procedure.
    - ◇ Yes: Perform any actions indicated in the system operator message. If you need further assistance, contact your next level of support. This ends the procedure.

Parent topic: [Analyzing problems](#)

---

## Intermittent problems

An intermittent problem is a problem that occurs for a short time, and then goes away.

The problem may not occur again until some time in the future, if at all. Intermittent problems cannot be made to appear again easily.

Some examples of intermittent problems are:

- A reference code appears on the control panel (the system attention light is on) but disappears when you power off, then power on the system. An entry does not appear in the Product Activity Log.
- An entry appears in the problem log when you use the Work with Problems (WRKPRB) command. For example, the 50/94 expansion unit becomes powered off, but starts working again when you power it on.
- The workstation adapter is in a hang condition but starts working normally when it gets reset.

**Note:** You can get equipment for the following conditions from your branch office or installation planning representative:

- If you suspect that the air at the system site is too hot or too cold, you need a thermometer to check the temperature.
- If you suspect the moisture content of the air at the system site is too low or too high, use a wet/dry bulb to check the humidity. See [General intermittent problem checklist](#) for more information.
- If you need to check ac receptacles for correct wiring, you need an ECOS tester, Model 1023-100, or equivalent tester. The tester lets you quickly check the receptacles. If you cannot find a tester, use an analog multimeter instead. Do not use a digital multimeter.

Follow the steps below to correct an intermittent problem:

1. Read the information in [About intermittent problems](#) before you attempt to correct an intermittent problem. Then continue with the next step of this procedure.
  2. Perform *all* steps in the [General intermittent problem checklist](#). Then continue with the next step of this procedure.
  3. Did you correct the intermittent problem?
    - ◆ Yes: This ends the procedure.
    - ◆ No: Go to [Analyzing intermittent problems](#). This ends the procedure.
- 

## About intermittent problems

An intermittent problem can show many different symptoms, so it might be difficult for you to determine the real cause without completely analyzing the failure.

To help with this analysis, you should determine as many symptoms as possible.

- The complete reference code is necessary to determine the exact failing area and the probable cause.
- Product Activity Log (PAL) information can provide time and device relationships.
- Information about environmental conditions when the failure occurred can be helpful (for example, an electrical storm occurring when the failure happened).

**Note:** If you suspect that an intermittent problem is occurring, increase the log sizes to the largest sizes possible. Select the PAL option on the Start a Service Tool display (see [Product Activity Log](#) for details).

## Types of intermittent problems

Following are the major types of intermittent problems:

- Code (PTFs):
  - ◆ Licensed internal code
  - ◆ Licensed program products
  - ◆ Other application software
- Configuration:
  - ◆ Non-supported hardware that is used on the system
  - ◆ Non-supported system configurations
  - ◆ Non-supported communication networks
  - ◆ Model and feature upgrades that are not performed correctly
  - ◆ Incorrectly configured or incorrectly cabled devices
- Environment:
  - ◆ Power line disturbance (for example, reduced voltage, a pulse, a surge, or total loss of voltage on the incoming ac voltage line)
  - ◆ Power line transient (for example, lightning strike)
  - ◆ Electrical noise (constant or intermittent)
  - ◆ Defective grounding or a ground potential difference
  - ◆ Mechanical vibration
- Intermittent hardware failure

## General intermittent problem checklist

Use the following procedure to correct intermittent problems.

Performing these steps removes the known causes of most intermittent problems.

1. Discuss the problem with the customer. Look for the following symptoms:
  - ◆ A reference code that goes away when you power off and then power on the system.
  - ◆ Repeated failure patterns that you cannot explain. For example, the problem occurs at the same time of day or on the same day of the week.
  - ◆ Failures that started after system relocation.
  - ◆ Failures that occurred during the time specific jobs or software were running.
  - ◆ Failures that started after recent service or customer actions, system upgrade, addition of I/O devices, new software, or program temporary fix (PTF) installation.
  - ◆ Failures occurring only during high system usage.
  - ◆ Failures occur when people are close to the system or machines are attached to the system.
2. Recommend that the customer install the latest cumulative PTF package, since code PTFs have corrected many problems that seem to be hardware failures. The customer can order the latest cumulative PTF package electronically through Electronic Customer Support or by calling the

Software Support Center.

3. If you have not already done so, use the maintenance package to see the indicated actions for the symptom described by the customer. Attempt to perform the on-line problem analysis procedure first. If this is not possible, such as when the system is down, go to the [Start of call procedure](#).

Use additional diagnostic tools, if necessary, and attempt to recreate the problem.

**Note:** Ensure that the service information you are using is at the same level as the operating system.

4. Check the site for the following environmental conditions:
  - a. Any electrical noise that matches the start of the intermittent problems. Ask the customer such questions as:
    - ◇ Have any external changes or additions, such as building wiring, air conditioning, or elevators been made to the site?
    - ◇ Has any arc welding occurred in the area?
    - ◇ Has any heavy industrial equipment, such as cranes, been operating in the area?
    - ◇ Have there been any thunderstorms in the area?
    - ◇ Have the building lights become dim?
    - ◇ Has any equipment been relocated, especially computer equipment?
 If there was any electrical noise, find its source and prevent the noise from getting into the system.
  - b. Site temperature and humidity conditions that are within the system specifications. See [Temperature and humidity design criteria](#) in the [Planning](#) topic.
  - c. Poor air quality in the computer room:
    - ◇ Look for dust on top of objects. Dust particles in the air cause poor electrical connections and may cause disk unit failures.
    - ◇ Smell for unusual odors in the air. Some gases can corrode electrical connections.
  - d. Any large vibration (caused by thunder, an earthquake, an explosion, or road construction) that occurred in the area at the time of the failure.

**Note:** A failure that is caused by vibration is more probable if the server is on a raised floor.

5. Ensure that all ground connections are tight. These items reduce the effects of electrical noise. Check the ground connections by measuring the resistance between a conductive place on the frame to building ground or to earth ground. The resistance must be 1.0 ohm or less.
6. Ensure proper cable retention is used, as provided. If no retention is provided, the cable should be strapped to the frame to release tension on cable connections.

Ensure that you pull the cable ties tight enough to fasten the cable to the frame bar tightly. A loose cable can be accidentally pulled with enough force to unseat the logic card in the frame to which the cable is attached. If the system is powered on, the logic card could be destroyed.

7. Ensure that all workstation and communications cables meet hardware specifications:
  - ◆ All connections are tight.
  - ◆ Any twinaxial cables that are not attached to devices must be removed.
  - ◆ The lengths and numbers of connections in the cables must be correct.
  - ◆ Ensure that lightning protection is installed on any twinaxial cables that enter or leave the building.
8. Perform the following:
  - a. Review recent service calls. Contact your next level of support for assistance.
  - b. Review entries in the problem log (WRKPRB). Look for problems that were reported to the user.
  - c. Review entries in the PAL, SAL, and service processor log. Look for a pattern:
    - ◇ SRCs on multiple adapters occurring at the same time
    - ◇ SRCs that have a common time-of-day or day-of-week pattern
    - ◇ Log is wrapping (hundreds of recent entries and no older entries)
 Check the PAL sizes and increase them if they are smaller than recommended.
  - d. Review entries in the history log (Display Log (DSPLDG)). Look for a change that matches the start of the intermittent problems.
  - e. Ensure that the latest engineering changes are installed on the system and on all system I/O devices.

9. Ensure that the hardware configuration is correct and that the model configuration rules have been followed. Use the Display hardware configuration service function (under SST or DST) to check for any missing or failed hardware.
  10. Was a system upgrade, feature, or any other field bill of material or feature field bill of material installed just before the intermittent problems started occurring?
    - ◆ No: Continue with the next step.
    - ◆ Yes: Review the installation instructions to ensure that each step was performed correctly. Then continue with the next step of this procedure.
  11. Is the problem associated with a removable media storage device?
    - ◆ No: Continue with the next step.
    - ◆ Yes: Ensure that the customer is using the correct removable media storage device cleaning procedures and good storage media. Then continue with the next step of this procedure.
  12. Perform the following to help prevent intermittent thermal checks:
    - ◆ Ensure that the AMDs are working.
    - ◆ Exchange all air filters as recommended.
  13. If necessary, review the intermittent problems with your next level of support and installation planning representative. Ensure that all installation planning checks were made on the system. Because external conditions are constantly changing, the site may need to be checked again. This ends the procedure.
- 

## Analyzing intermittent problems

This procedure enables you to begin analyzing an intermittent problem.

Use this procedure only after you have first reviewed the information in [About intermittent problems](#) and gone through the [General intermittent problem checklist](#).

1. Is a reference code associated with the intermittent problem?
    - ◆ No: Continue with the next step.
    - ◆ Yes: Go to [Reference codes](#). If the actions in the reference code tables do not correct the intermittent problem, return here and continue with the next step.
  2. Is a symptom associated with the intermittent problem?
    - ◆ No: Continue with the next step.
    - ◆ Yes: Go to [Intermittent symptoms](#). If the information there does not help to correct the intermittent problem, return here and continue with the next step.
  3. Go to [Failing area intermittent isolation procedures](#). If the information there does not help to correct the intermittent problem, return here and continue with the next step.
  4. Send the data you have collected to your next level of support so that an Authorized Program Analysis Report (APAR) can be written. This ends the procedure.
- 

## Intermittent symptoms

Use the table below to find the symptom and description of the intermittent problem. Then perform the corresponding intermittent isolation procedures.

Although an isolation procedure may correct the intermittent problem, use your best judgment to determine if you should perform the remainder of the procedure shown for the symptom.

**Note:** If the symptom for the intermittent problem you have is not listed, go to [Failing area intermittent isolation procedures](#).

Table 1. Intermittent symptoms

| Symptom                        | Description                                                                                                                                                                                                                           | Isolation procedure     |
|--------------------------------|---------------------------------------------------------------------------------------------------------------------------------------------------------------------------------------------------------------------------------------|-------------------------|
| System powered off.            | The system was operating correctly, then the system powered off. A 1xxx SRC may occur when this happens, and this SRC info should be logged in the service processor log.                                                             | <a href="#">INTIP09</a> |
| System stops.                  | The system is powered on but is not operating correctly. No SRC is displayed. The system attention light is off and the processor activity lights may be on or off. Noise on the power-on reset line can cause the processor to stop. | <a href="#">INTIP18</a> |
| System or subsystem runs slow. | The system or the subsystem is not processing at its normal speed.                                                                                                                                                                    | <a href="#">INTIP20</a> |

## INTIP09

Use this procedure to check the AC electrical power for the system.

1. Have an **installation planning representative** or an electrician (when necessary), perform the following steps.
2. Power off the server and the power network branch circuits before performing this procedure (see [Powering on and powering off](#)).
3. To ensure the safety of personnel, all electrical wiring in the United States must meet National Electrical Code requirements.
4. Check **ALL** system receptacles to ensure that each is wired correctly. This includes receptacles for the server and all equipment that attaches to the server, including workstations. Do this to determine if a wire with primary voltage on it has been swapped with the ground wire, causing an electrical shock hazard.
5. When three-phase voltage is used to provide power to the server, correct balancing of the load on each phase is important. The units should be connected so that all three phases are used equally.
6. The power distribution neutral must return to the "separately derived source" (uninterruptable power supply, service entrance transformer, system power module, motor generator) through an insulated wire that is the same size as the phase wire or larger.
7. The server and its attached equipment should be the only units that are connected to the power distribution network that the server gets its power.
8. The equipment that is attached to the server, such as workstations and printers, must be attached to the power distribution network for the server when possible.
9. Check all circuit breakers in the network that supply ac power to the server as follows:
  - ◆ Ensure that the circuit breakers are installed tightly in the power panel and are not loose.
  - ◆ Feel the front surface of each circuit breaker to detect if it is warm. A warm circuit breaker may be caused by:
    - ◇ The circuit breaker that is not installed tightly in the power panel.
    - ◇ The contacts on the circuit breaker that is not making a good electrical connection with the contacts in the power panel.
    - ◇ A defective circuit breaker.
    - ◇ A circuit breaker of a smaller current rating than the current load which is going through it.
    - ◇ Devices on the branch circuit which are using more current than their rating.
10. Equipment that uses a large amount of current, such as: Air conditioners, copiers, and FAX machines, should not receive power from the same branch circuits as the system or its workstations. Also, the wiring that provides ac voltage for this equipment should not be placed in the same conduit as the ac voltage wiring for the server. The reason for this is that this equipment generates ac noise pulses. These pulses can get into the ac voltage for the server and cause intermittent problems.
11. Measure the ac voltage to each unit to ensure that it is in the normal range.

Is the voltage outside the normal range?

- ◆ **No:** Continue with the next step.

- ◆ **Yes:** Contact the customer to have the voltage source returned to within the normal voltage range.

12. **The remainder of this procedure is only for a server that is attached to a separately derived source.**

Some examples of separately derived sources are an uninterruptible power supply, a motor generator, a service entrance transformer, and a system power module.

The ac voltage system must meet all the requirements that are stated in this procedure and also all of the following:

**Notes:**

- a. The following applies to an uninterruptible power supply, but it can be used for any separately derived source.
- b. System upgrades **must not** exceed the power requirements of your derived source.

The uninterruptible power supply must be able to supply the peak repetitive current that is used by the system and the devices that attach to it. The uninterruptible power supply can be used over its maximum capacity if it has a low peak repetitive current specification, and the uninterruptible power supply is already fully loaded. Therefore, a de-rating factor for the uninterruptible power supply must be calculated to allow for the peak-repetitive current of the complete system. To help you determine the de-rating factor for an uninterruptible power supply, use the following:

**Note:** The peak-repetitive current is different from the "surge" current that occurs when the server is powered on.

The de-rating factor equals the crest factor multiplied by the RMS load current divided by the peak load current where the:

- ◆ Crest factor is the peak-repetitive current rating of the uninterruptible power supply that is divided by the RMS current rating of the uninterruptible power supply. If you do not know the crest factor of the uninterruptible power supply, assume that it is 1.414.
- ◆ RMS load current is the steady state RMS current of the server as determined by the power profile.
- ◆ Peak load current is the steady state peak current of the server as determined by the power profile.

For example, if the de-rating factor of the uninterruptible power supply is calculated to be 0.707, then the uninterruptible power supply must not be used more than 70.7% of its kVA-rated capacity. If the kVA rating of the uninterruptible power supply is 50 kVA, then the maximum allowable load on it is 35.35 kVA (50 kVA multiplied by 0.707).

When a three-phase separately derived source is used, correct balancing of the load as specified in step 5 is **critical**. If the load on any one phase of an uninterruptible power supply is more than the load on the other phases, the voltage on all phases may be reduced.

13. If the system is attached to an uninterruptible power supply or motor generator, then check for the following:
  - ◆ The system and the attached equipment should be the only items that are attached to the uninterruptible power supply or motor generator. Equipment such as air conditioners, copiers, and FAX machines should not be attached to the same uninterruptible power supply, or motor generator that the system is attached.
  - ◆ The system unit console and the Electronic Customer Support modem must get ac voltage from the same uninterruptible power supply or motor generator to which the system is attached. **This ends the procedure.**

**Parent topic:** [Intermittent isolation procedures](#)

---



## INTIP18

Use this procedure to determine if one or more PTFs are available to correct this specific problem.

1. Ensure that all PTFs that relate to the problem have been installed.

**Note:** Ensure that the latest platform LIC fix has been installed before you exchange a service processor.

2. Contact your next level of support for more information. **This ends the procedure.**

**Parent topic:** [Intermittent isolation procedures](#)

---

## INTIP20

Use this procedure to analyze system performance problems.

1. Look in the Product Activity Log (PAL), ASM log, or HMC to determine if any hardware errors occurred at the same time that the performance problem occurred. Did any hardware problems occur at the same time that the performance problem occurred?
  - ◆ **Yes:** Go to [Start of call procedure](#) and correct the hardware errors. **This ends the procedure.**
  - ◆ **No:** The performance problems are not related to hardware. Continue with the next step.
2. Perform the following steps:
  - a. Ask the customer if they have asked software support for any software PTFs that relate to this problem.
  - b. Recommend that the customer install a cumulative PTF package if they have not done so in the past three months.
  - c. Inform the customer that performance could possibly be improved by having Software Support analyze the conditions.
  - d. Inform the customer that your service provider has performance tools. Contact Software Support for more information. **This ends the procedure.**

**Parent topic:** [Intermittent isolation procedures](#)

---

## Failing area intermittent isolation procedures

This procedure helps you determine how to resolve intermittent problems when you do not have a system reference code (SRC) or cannot determine the symptom.

Use this table only if you do not have a system reference code (SRC), or cannot find your symptom in [Intermittent symptoms](#).

1. Perform all of the steps in [General intermittent problem checklist](#) for all failing areas. Then continue with the next step.
2. Refer to the table below, and perform the following:
  - a. Find the specific area of failure under Failing area.
  - b. Look down the column of the area of failure until you find an X.
  - c. Look across to the Isolation procedure column and perform the procedure indicated.
  - d. If the isolation procedure does not correct the intermittent problem, continue down the column of the area of failure until you have performed all of the procedures shown for the failing area.
3. Although an isolation procedure may correct the intermittent problem, use your best judgment to determine if you should perform the remainder of the procedures shown for the failing area.

Table 1. Failing area intermittent isolation procedures

| Failing area |                            |                   |      |               |              | Isolation procedure to perform:                        |
|--------------|----------------------------|-------------------|------|---------------|--------------|--------------------------------------------------------|
| Power        | Work station I/O processor | Disk unit adapter | Comm | Processor bus | Tape optical | Perform all steps in:                                  |
| X            | X                          | X                 | X    | X             | X            | <a href="#">General intermittent problem checklist</a> |
| X            | X                          |                   |      | X             |              | <a href="#">INTIP05</a>                                |
|              | X                          | X                 | X    | X             | X            | <a href="#">INTIP07</a>                                |
| X            |                            |                   |      |               |              | <a href="#">INTIP09</a>                                |
| X            |                            |                   |      |               |              | <a href="#">INTIP14</a>                                |
|              |                            | X                 |      |               |              | <a href="#">INTIP16</a>                                |
| X            | X                          | X                 | X    | X             | X            | <a href="#">INTIP18</a>                                |
|              | X                          | X                 | X    | X             | X            | <a href="#">INTIP20</a>                                |

## INTIP05

Use this procedure to isolate problems with external noise on twinaxial cables.

Electrical noise on twinaxial cables that are not installed correctly may affect the twinaxial workstation I/O processor card.

Examples of this include open shields on twinaxial cables, and station protectors that are not being installed where necessary.

Check for the following on the system:

- There must be no more than 11 connector breaks in a twinaxial cable run.
- Station protectors must be installed (in pairs) where a cable enters or leaves a building.
- There can only be two station protectors for each twinaxial run.
- There is a maximum of seven devices (with addresses 0-6) for each cable run.
- There is a maximum cable length of 1524 meters (5000 feet) for each port.
- All cable runs must be ended (terminated).
- Disconnect all twinaxial cables that are not used.
- Remove any cause of electrical noise in the twinaxial cables.
- All workstations must be grounded.

**This ends the procedure.**

Parent topic: [Intermittent isolation procedures](#)

## INTIP07

Use this procedure to lessen the effects of electrical noise (electromagnetic interference, or EMI) on the system.

1. Ensure that air flow cards are installed in all adapter card slots that are not used.
2. Keep all cables away from sources of electrical interference, such as ac voltage lines, fluorescent lights, arc welding equipment, and radio frequency (RF) induction heaters. These sources of electrical

noise can cause the system to become powered off.

3. If you have an expansion unit, ensure that the cables that attach the system unit to the expansion unit are seated correctly.

**Note:** If the failures occur when people are close to the system or machines that are attached to the system, the problem may be electrostatic discharge (ESD).

4. Have an **installation planning representative** use a radio frequency (RF) field intensity meter to determine if there is an unusual amount of RF noise near the server. You also can use it to help determine the source of the noise. **This ends the procedure.**

Parent topic: [Intermittent isolation procedures](#)

---

## INTIP14

Use this procedure to isolate problems with station protectors.

Station protectors must be installed on all twinaxial cables that leave the building in which the server is located. This applies even if the cables go underground, through a tunnel, through a covered outside hallway, or through a skyway. Station protectors help prevent electrical noise on these cables from affecting the server.

1. Look at the Product Activity Log to determine what workstations are associated with the failure.
2. Determine if station protectors are installed on the twinaxial cables to the failing workstations.

Are station protectors installed on the twinaxial cables to the failing workstations?

- ◆ **Yes:** Perform the next intermittent isolation procedure listed in the *Isolation procedure* column. **This ends the procedure.**
- ◆ **No:** You may need to install station protectors on the twinaxial cables to the failing workstations. **This ends the procedure.**

Parent topic: [Intermittent isolation procedures](#)

---

## INTIP16

Use this procedure when you need to copy a main storage dump to give to your next level of support.

For some problems, performing a dump of main storage helps to analyze the problem. The data on the dump is analyzed by support personnel to determine the cause of the problem and how to correct it.

1. Copy the main storage dump to tape. See [Copying a dump](#) in the [Troubleshooting](#) topic.
2. Ask your next level of support to determine for assistance. **This ends the procedure.**

Parent topic: [Intermittent isolation procedures](#)

---

## IPL problems

Use these scenarios to help you diagnose your IPL problem:

- **Cannot perform IPL from the control panel (no SRC)**  
Use this procedure when you cannot perform an IPL from the control panel (no SRC).

- **Cannot perform IPL at a specified time (no SRC)**

Use this procedure when you cannot perform an IPL at a specified time (no SRC). To correct the IPL problem, perform this procedure until you determine the problem and can perform an IPL at a specified time.

- **Cannot automatically perform an IPL after a power failure**

Use this procedure when you cannot automatically perform an IPL after a power failure.

Parent topic: [Analyzing problems](#)

---

## Cannot perform IPL from the control panel (no SRC)

Use this procedure when you cannot perform an IPL from the control panel (no SRC).

**DANGER**An electrical outlet that is not correctly wired could place hazardous voltage on the metal parts of the system or the devices that attach to the system. It is the responsibility of the customer to ensure that the outlet is correctly wired and grounded to prevent an electrical shock. (D004)

1. Perform the following:
  - a. Verify that the power cable is plugged into the power outlet.
  - b. Verify that power is available at the customer's power outlet.
2. Start an IPL by doing the following:
  - a. Select Manual mode and IPL type A or B on the control panel. See [Control panel functions](#) for details.
  - b. Power on the system. See [Powering on and powering off](#).

Does the IPL complete successfully?

  - ◆ No: Continue with the next step.
  - ◆ Yes: This ends the procedure.
3. Have all the units in the system become powered on that you expected to become powered on?
  - ◆ Yes: Continue with the next step.
  - ◆ No: Go to [Power problems](#) and find the symptom that matches the problem. This ends the procedure.
4. Is an SRC displayed on the control panel?
  - ◆ Yes: Go to [Power problems](#) and use the displayed SRC to correct the problem. This ends the procedure.
  - ◆ No: For all models, exchange the following FRUs, one at a time. Refer to the [Removing and replacing parts](#) for additional information.
    - a. SPCN card unit. See symbolic FRU [TWRCARD](#).
    - b. Power Supply. See symbolic FRU [PWRSPLY](#). This ends the procedure.

Parent topic: [IPL problems](#)

---

## Control panel functions

For details on using the control panel, see the following information.

### Notes:

1. Systems managed by the Hardware Management Console (HMC) should use the HMC to perform control panel functions. For information on performing control panel functions using the HMC, see [Control panel functions](#).
2. Some control panel functions might not be available on all system types.

3. The *x* can be any number 0 through 9, any letter A through F, or a blank.
4. If the customer was performing the function, find out why the customer selected the function and verify whether it is complete.
5. If you cannot change the *Function/Data* display or complete the selected function, go to [Start of call procedure](#).

Parent topic: [Powering on and powering off](#)

---

## Powering on and powering off

Provides information for powering on and powering off the system.

The following procedures may be performed by customers, and are located outside this topic:

[Start the system](#)

[Stop the system](#)

[Activating a partition profile](#)

[Shutting down](#)

These procedures are for authorized service providers only and are found in this topic:

- [Powering off an expansion unit](#)
- [Determining if a tower is configured as switchable under OptiConnect](#)  
You can determine if a tower is configured as a switchable tower under OptiConnect by performing the following procedure.
- [Switching ownership of a tower's switchable resources](#)  
It may be necessary for the local system to take or release ownership of a switchable resource.
- [Determining the power controlling and current logical system ownership of a tower](#)
- [Powering on an expansion unit](#)
- [Switching the mode of a tower's switchable resources](#)  
This procedure provides instructions on how to switch the mode of switchable resources in a tower.
- [Control panel functions](#)
- [Using the control panel power button to power off](#)
- [Verify the RIO/HSL loops with an HMC](#)
- [Verify the RIO/HSL loops without an HMC](#)

Parent topic: [Reference information](#)

---

## Determining if a tower is configured as switchable under OptiConnect

You can determine if a tower is configured as a switchable tower under OptiConnect by performing the following procedure.

**Note:** To perform this procedure, you must have the resource name of the high speed link (HSL) I/O bridge resource.

1. Move to the console of the system where you know the name of the HSL I/O bridge resource in the tower.
2. Sign on to the System Service Tool (SST) or Dedicated Service Tool (DST).
3. From the SST or DST, select Start a service tool, then Hardware Service Manager.

4. From the Hardware Service Manager, select Logical Hardware Resources.
5. From the Logical Hardware Resources display, select High Speed Link Resources.
6. From the High Speed Link Resources display, select the function Include non-reporting resources.
7. Move the cursor to the HSL I/O bridge resource of the tower and select the Display detail option. The Display HSL Information display appears.

Figure 1. Example Display High Speed Link (HSL) Information display

```

Display HSL Information

HSL loop number . . . . . : 257

HSL I/O bridge resource
Type-model . . . : 1999-999          Status . . . . . : Operational
Serial number . . : 21-1111111      Part number . . . : 11111111111
Resource name . . : BC06            Mode: Switchable

Leading port to next resource . . . . . :
Link status . . : Operational      Link type . . . : Copper
Type of connection . . . . . : Internal

Trailing port from previous resource . . . . . : A1
Link status . . : Disabled        Link type . . . : Optical
Type of connection . . . . . : External

F3=Exit   F6=Print   F7=Follow trailing port   F8=Follow leading port
F9=Include non-reporting resources   F11=Display system information
F12=Cancel

```

8. At the Display HSL Information display, locate the Mode information of the resource.

**Note:** If you cannot locate the Mode information, then this HSL resource is not part of a Cluster Resource Group (CRG) and the tower where this HSL I/O bridge resource is located cannot be configured as switchable under OptiConnect.

9. Is the mode listed as *Private* or is the mode not displayed for this resource?
  - ◆ Yes = the tower where this HSL I/O bridge resource is located cannot be configured as switchable under OptiConnect. This ends the procedure.
  - ◆ No = the HSL I/O bridge resource has a mode of *switchable*. The tower is configured as a switchable tower under OptiConnect. Continue with the next step of this procedure.
10. Record the HSL loop number, the type-model, and the serial number of the HSL I/O bridge resource.

**Note:** You will need the type-model and serial number to identify the HSL I/O bridge on the other system that can own this resource.

Parent topic: [Powering on and powering off](#)

---

## Switching ownership of a tower's switchable resources

It may be necessary for the local system to take or release ownership of a switchable resource.

You can use the *Take/release ownership* option on the Select I/O Debug Function display to have the local system take ownership of a resource or to have the local system release its ownership of a resource. Ownership of a resource indicates which system controls the functions of a resource. Ownership may be released only by the system that presently owns it.

The following procedure will direct you to switch ownership of switchable resources in a tower from the current owner to the alternate system that can own those resources. To perform this procedure, you must know:

- The system that currently owns the switchable resources in a tower. This is the system that you are going to *release* the resources from.
- The alternate system that can *take* ownership of the switchable resources.
- The resource name of the high speed link (HSL) I/O bridge resource and the HSL loop number on the currently owning system that will *release* ownership.
- The resource name of the high speed link (HSL) I/O bridge resource and the HSL loop number on the system that will *take* ownership.

**Attention:** Perform this procedure only if you are not able to switch the ownership of the resource using the OptiConnect user interface. Cluster Resource Group (CRG) problems may occur as the result of using this procedure when the OptiConnect user interface is available.

1. Determine the current owner of the switchable resources in the tower if you have not already done so. (See the procedure [Determining the power controlling and current logical system ownership of a tower.](#))
2. Move to the console of the system that is the current owner of the switchable resources in the tower.
3. Sign on to System Service Tool (SST) or Dedicated Service Tool (DST).
4. Select Start a service tool.
5. Select Hardware Service Manager.
6. Select Logical Hardware Resources.
7. Select High speed link resources.
8. Select the function Include non-reporting resources.
9. Move the cursor to the HSL I/O bridge resource in the tower. Search for the resource name that the currently owning system assigned to the HSL I/O bridge resource.
10. Select the I/O Debug option.

When you select the I/O debug option on an HSL I/O bridge that has the capability of being switched, the following screen is displayed:

*Figure 1. Example I/O Debug Function display*

```

                                Select I/O Debug Function

Resource name . . . . . : BC06
Type-Model . . . . . : 1999-999
Serial number . . . . . : 21-1111111
Mode . . . . . : Switchable

```

Select one of the following:

1. Change mode
2. Take/release ownership

Selection

-

F3=Exit            F12=Cancel

11. From the Select I/O Debug Function display, select the Take/release ownership option. The following display appears:

*Figure 2. Example Confirm Release of Resource Ownership display*

```
Confirm Release of Resource Ownership

This system presently has ownership of this resource.
You have requested that the ownership of this resource be released.

Resource details
Resource name:    BC06
Type-Model . . : 1999-999
Serial number:   21-1111111

Current owning system
Type. . . . .: 9406
Serial number:  10-0033333

Potential owning system
Type. . . . .: 9406
Serial number:  10-1234567

Warning:  You should only attempt this action at the direction of your
          service representative.

Press Enter to release the ownership of this resource.

F12=Cancel
```

**Note:** If you select option two to release ownership of the resource and another system currently owns it, the following message appears at the bottom of the screen:

```
Ownership of this resource cannot be released. It is owned by another
system.
```

12. Record the type-model and the serial number of the HSL I/O bridge resource if you have not already done so.
13. Press Enter to confirm releasing the resource.
14. Move to the console of the other system that can take ownership of the switchable resources in the tower.
15. Sign on to System Service Tool (SST) or Dedicated Service Tool (DST).
16. Select Start a service tool.
17. Select Hardware Service Manager.
18. Select Logical Hardware Resources.
19. Select High speed link resources.
20. Select the function Include non-reporting resources.
21. Move the cursor to the HSL I/O bridge resource in the tower. Search for the resource name that this system assigned to the HSL I/O bridge resource.
22. Select the I/O Debug option.
23. From the Select I/O Debug Function display, select the Take/release ownership option. The following screen will appear:

*Figure 3. Example Confirm Ownership Change display*

```
Confirm Ownership Change

You have requested that this system take ownership of this resource.

Resource details
Resource name:    BC06
Type-Model . . : 1999-999
Serial number:   21-1111111
```



## Service provider information

Warning: You should only attempt this action at the direction of your service representative.

Press Enter to take ownership of this resource.

F12=Cancel

24. Press Enter to confirm the ownership change. This ends the procedure.

**Parent topic:** [Powering on and powering off](#)

---

## Determining the power controlling and current logical system ownership of a tower

You can determine the power controlling system of a tower by performing the following procedure.

1. From the Logical Hardware Resources screen, select High-Speed Link Resources.
2. Go to the HSL Loop with the tower you wish to learn about. Select option 5 (Display detail) and press Enter.
3. Press F8 (Follow Leading Port) until you reach the tower you want to learn about.
4. Press F11 (Display System Information). There will be a section called SPCN System Information. That will have the system serial number for the power controlling system. The current logical owning system will be labeled as "owner."

**Parent topic:** [Powering on and powering off](#)

---

## Powering on an expansion unit

**Attention:** Before beginning read this entire procedure. If there are procedural steps that cannot be performed at this time, the procedure must be delayed until a later time.

**Attention:** If the server is HMC-managed, the power off and power on functions must be performed using the Power On/Off Unit utility on the HMC. To use the Power On/Off Unit utility, do the following when instructed to in the procedure below:

1. In the navigation area, open the Service Applications folder.
2. Select Service Focal Point.
3. In the contents area, select Service Utilities.
4. In the Service Utilities window, select the system you are working on.
5. Select Selected > Power On/Off Unit

If the server is not HMC-managed, the power off and power on functions must be performed using the Packaging Hardware Resources utility from the service partition. To use the Packaging Hardware Resources, go to the System Service Tools or the Dedicated Service Tools and do the following when instructed to in the procedure below:

1. Select Start a service tool
2. Select Hardware service manager
3. Select Packaging hardware resources
4. Select Concurrent maintenance

If the server is not HMC-managed and there is no service partition, the expansion unit cannot be powered off and on with the server powered on.

**Attention:** Do *not* use this procedure to replace disk units that are supported under device concurrent maintenance. Use the device concurrent maintenance procedure instead.

**Attention:** Do *not* use this procedure on the system unit or the system unit's integrated expansion unit. For system units and system units integrated expansion units see [Powering on and powering off](#)

**Note:**

1. References to the console in this procedure refer to the console of the logical partition in which you are working.
2. Throughout this procedure, the term *HSL I/O bridge* is interchangeable with *RIO adapter*.
3. Throughout this procedure, the term *tower* is interchangeable with *expansion unit*.
4. Messages that may be generated on the HMC during the procedure refer to specific partitions by their partition IDs. A partition's ID is a numeric value that represents the order in which the partitions were created. The partitions listed in the Server Management content area are not necessarily listed in order of partition ID. A partition's ID is listed under the *General* tab in the Partition Properties.

**Note:** Perform the following with the assistance of the customer.

1. If the ac power cords were disconnected when the expansion unit was powered off and have not been reconnected, reconnect them now. If they are already connected go to [step 2](#).
  - ◆ The expansion unit will automatically power on when the ac power cords are connected.
  - ◆ If this is a non-HMC-managed , go to [step 2](#).
  - ◆ If this is an HMC-managed server, power off the expansion unit again. See [Powering off an expansion unit](#). Then go to [step 3](#).
2. Were you instructed to perform a function 69 to power on the expansion unit?
  - ◆ No: Go to [step 3](#).
  - ◆ Yes: Perform function 69 (with the control panel set to manual mode) from the system unit control panel. See [Control panel functions](#). Then go to [step 4](#).
3. Power on the expansion unit using either the "Power On/Off Unit" utility from the HMC, or the "Packaging Hardware Resources" utility from the i5/OS service partition, as described at the top of this page. Follow the instructions provided by the utility to complete the power on. Go to [step 4](#).

**Note:** If you are required to do this step using the Packaging Hardware Resources utility from the i5/OS service partition, but the Packaging Hardware Resources utility cannot be accessed, you may be able power on the expansion unit using the system control panel as follows.

- ◆ With the control panel set to manual mode, select function 07 and press Enter.
  - ◆ Increment to A1 and press Enter. This will send out a **Rack Power On** command on the SPCN which will restore power any expansion unit that is powered off.
  - ◆ See [Control panel functions](#) for further information on control panel functions and how to use them.
4. Wait for I/O resources in the expansion unit to be brought back online to a functional state, then go to [step 5](#).
- It may take between five and ten minutes after the expansion unit is powered on for i5/OS resources in the expansion unit to return to a functional/operational state. Using the Packaging Hardware Resources and Logical Hardware Resources utilities in the Hardware Service Manager utility, you can determine when resources in the expansion unit return to a functional/operational state by observing the transition of the resources from non-reporting (designated by a "?" next to the resources) to reporting (designated by the absence of a "?" next to the resources) and/or Unknown, Not Connected, Failed, or Disabled status to Operational status. If there is a disk unit attention SRC in the partition operator panel and the Hardware Service Manager is not available, the transition to functional/operational has occurred when the disk unit attention SRC disappears and the partition resumes normal operation.
5. Work with the customer to restart all I/O bus activity that was ended when the expansion unit was powered off, then go to [step 6](#)
- ◆ In i5/OS partitions:
    - ◇ Work with the customer to vary on all configuration descriptions (ctl, device, line, network server, etc.) that were varied off when the expansion unit was powered off. This can be done using the vrycfg command.
    - ◇ Start all subsystems that were ended when the expansion unit was powered off.
  - ◆ In AIX partitions:
    - ◇ Work with the customer to configure all logical resources that were unconfigured when the expansion unit was powered off. This can be done using the cfgmgr command.
6. If you moved the ac power cords of an expansion unit from this expansion unit to an alternate ac power source when this expansion unit was powered off, then move them back to this expansion unit now. Move only one of the expansion unit's ac power cords at a time to prevent the expansion unit from losing ac power. Then go to [step 7](#).
7. If the expansion unit was configured as switchable when you powered off the expansion unit, and you changed the mode to private, work with the customer to restore the mode of the expansion unit to switchable using [Switching the mode of a tower's switchable resources](#). Then go to [step 8](#).
8. If you ended Cluster Resource Groups (CRGs) when you powered off the expansion unit, work with the customer to start the CRGs. Then go to [step 9](#).
9. If ownership of the expansion unit's HSL I/O bridge was changed when the expansion unit was powered off, work with the customer to restore the desired ownership. Return to the procedure that sent you here.

**Parent topic:** [Powering on and powering off](#)

---

## Switching the mode of a tower's switchable resources

This procedure provides instructions on how to switch the mode of switchable resources in a tower.

**Note:** To perform this procedure, the switchable resources in the tower must be owned by the power controlling system for the tower. For information on switching ownership of the switchable resources in a tower, see the procedure [Switching ownership of a tower's switchable resources](#).

**Attention:** Perform this procedure only if you are not able to end the Cluster Resource Group (CRG) using the OptiConnect user interface. CRG problems may occur as the result of using this procedure when the OptiConnect user interface is available.

1. Move to the console of the power controlling system of the tower.
2. Sign on to System Service Tool (SST) or Dedicated Service Tool (DST).
3. Select Start a service tool.
4. Select Hardware Service Manager.
5. Select Logical hardware resources.
6. Select High speed link resources.
7. Select the function Include non-reporting resources.
8. Move the cursor to the HSL I/O bridge resource in the tower. Search for the resource name that the currently owning system assigned to the HSL I/O bridge resource.
9. Select the I/O Debug option.
10. From the Select I/O Debug Function display, select the Change mode option. The following display appears:

*Figure 1. Example Confirm Mode Change display*

```

Confirm Mode Change

You have requested the following change to a logical resource:

Resource details
Resource name:   BC06
Type-Model:     1999-999
Serial number:  21-1111111

Present value
Tower mode:     Switchable

Requested value
Tower mode:     Private

Warning:  You should only attempt this action at the direction of your
service representative.

Press Enter to confirm the change.

F12=Cancel

```

11. Is the present value of the tower mode a value that you want to change?
  - ◆ Yes = proceed to the next step.
  - ◆ No = The power is already in the mode you want it to be in. This ends the procedure.
12. Press Enter to confirm changing the mode of the resource.

If you press Enter at the Confirm Mode Change display, one of the following messages will appear:

- ◆ Change mode was successful.
  - ◆ Unable to change mode for this hardware resource.
- This ends the procedure.

**Parent topic:** [Powering on and powering off](#)

---

## Verify the RIO/HSL loops with an HMC

Complete the following steps to verify the RIO/HSL loops with an HMC and the system unit power on:

1. If you were sent here from [Powering off an expansion unit](#) as part of a repair procedure, skip to step 3.
2. Use the HMC to verify that there are no B700 69xx errors by completing the following steps:
  - a. In the navigation area of the HMC, expand Management Environment.
  - b. Expand the management environment you are working with.
  - c. Expand Service Applications.
  - d. Select Service Focal Point.
  - e. In the contents area, select Manage Serviceable Events.
  - f. In the Manage Serviceable Events Select Serviceable Events window, select Open for the Serviceable Event Status, select the MTMS of the server you are working with for Reporting MTMS, and select ALL for all other fields.
  - g. Click OK.
  - h. Scan for any B700 69xx errors.
    - ◇ If there are no errors, click Cancel to exit. Go to step 3
    - ◇ If there are errors, they must be corrected before continuing. If you need assistance, contact your service provider.
3. Use the HMC to verify the existing RIO/HSL loops by completing the following steps:
  - a. In the navigation area of the HMC, expand Management Environment.
  - b. Expand the management environment you are working with.
  - c. Expand Service Applications.
  - d. Select Service Focal Point.
  - e. Select Service Utilities.
  - f. Select the server you are working with.
  - g. Click Selected from the toolbar at the top of the window and select View RIO Topology from the drop down menu.
  - h. Verify that all of the entries of type External (ignore Internal links) have a LinkStatus of Operational. If the LinkStatus for all of the external entries is operational, continue to the next step. If the LinkStatus is not operational for any of the external entries, the links must be repaired before continuing. If you need assistance, contact your service provider.

**Note:** If you were sent here from [Powering off an expansion unit](#) during a repair procedure, it is possible that the LinkStatus values will not be Operational for the ports on the expansion unit being powered off and repaired. It is not necessary to correct those failures before proceeding.

4. Return to the procedure that sent you here.

Parent topic: [Powering on and powering off](#)

---

## Verify the RIO/HSL loops without an HMC

**Note:** This procedure must be done from a partition running i5/OS.

Complete the following steps to verify the RIO/HSL loops on a system that is not managed by an HMC with the system unit power on:

1. If you were sent here from [Powering off an expansion unit](#) as part of a repair procedure, skip to step 3.
2. Use the service action log to verify there are no B700 69xx errors. Complete the following steps to view the service action log:
  - a. Be sure you are signed on with at least service level authority.
  - b. On the command line of the i5/OS session, type strsst and press Enter.

**Note:** If you cannot get to the System Service Tools display, use function 21 from the control panel.

- c. Type your service tools user ID and service tools password on the System Service Tools (SST) Sign On display. Press Enter.

**Note:** The service tools password is case-sensitive.

- d. Select Start a service tool from the System Service Tools (SST) display. Press Enter.
- e. Select Hardware service manager from the Start a Service Tool display. Press Enter.
- f. Select Work with service action log from the Hardware Service Manager display. Press Enter.
- g. On the Select Timeframe display, change the From: Date and Time to the desired date and time range. The suggested range is 30 days.
- h. Search for any B700 69xx errors.

◇ If there are no errors, press F3 to exit and return to the Hardware Service Manager display. Go to step 3.

◇ If there are errors, they must be corrected before continuing. If you need assistance, contact your service provider.

3. Use the Hardware Service Manager to verify the existing RIO/HSL loop by completing the following steps:

- a. Type your service tools user ID and service tools password on the System Service Tools (SST) Sign On display. Press Enter.

**Note:** The service tools password is case-sensitive.

- b. Select Logical hardware resources from the Hardware Service Manager display. Press Enter.
- c. Select High-speed link resources from the Logical Hardware Resources display. Press Enter.
- d. Select Display port information for the first RIO/HSL loop. Press Enter.
- e. For each row that has a connection type of External, verify that the status is Operational. If the status is operational, press F12 to cancel and select Display port information for the next HSL/RIO loop. If all of the external RIO/HSL connections are operational, press F3 to exit and continue to the next step. If the status is not operational for any one of the external RIO/HSL connections, the links must be repaired before continuing. If you need assistance, contact your service provider.

**Note:** If you were sent here from [Powering off an expansion unit](#) during a repair procedure, it is possible that the status values will not be operational for the ports on the expansion unit being powered off and repaired. It is not necessary to correct those failures before proceeding.

4. Return to the procedure that sent you here.

**Parent topic:** [Powering on and powering off](#)

---

## TWRCARD

A SPCN card might be failing. The SPCN card can be on either an adapter style card or integrated on the system backplane.

Perform the following to service this FRU.

1. Are you here because your system produced system reference code (SRC) 1100 00AD?
  - ◆ **No:** Continue to the next step.
  - ◆ **Yes:** Yes.
    - ◇ The 1100 00AD SRC might be caused by the service processor being intentionally reset. An intentional reset is caused by actions like a pin hole reset, ASMI or part replacements. An intentional reset requires no service action.
    - ◇ If your system produced the 1100 00AD SRC and no intentional reset was the cause of this SRC, go to the next step.
2. A SPCN card might be failing. The SPCN card is located either on an adapter style card or integrated on the system backplane

**Note:**

Examine the location code of this FRU in the serviceable event screen you are working with to determine the unit's type and model (see [Location codes](#)). Locate the unit's type and model in the table below to determine the correct service action.

3. Is the system reference code (SRC) 1xxx 5000 or 1xxx 5001?
  - ◆ **No:** Continue to the next step.
  - ◆ **Yes:** Yes.
    - ◇ For SRC 1xxx 5000:
      - For model ESCALA PL 1650R-L+ and ESCALA PL 850R/PL 1650R/R+, replace the service processor in Unit 1 (see [Locations model ESCALA PL 850R/PL 1650R/R+](#) locations information)
      - For model ESCALA PL 3250R, PL 3250R+, ESCALA PL 6450 or PL 6450R+, replace service processor 0 (see [Locations model ESCALA PL 3250R or ESCALA PL 6450R](#))
    - ◇ For SRC 1xxx 5001:
      - For model ESCALA PL 1650R-L+ or ESCALA PL 850R/PL 1650R/R+, replace the service processor in Unit 2 (see [Locations model ESCALA PL 850R/PL 1650R/R+](#) locations information)
      - For model ESCALA PL 3250R, PL 3250R+, ESCALA PL 6450 or PL 6450R+, replace service processor 1 (see [Locations model ESCALA PL 3250R or ESCALA PL 6450R](#))
4. Verify that all cables are seated correctly.
5. Examine the location code of this FRU in the serviceable event view you are working with to determine the unit's type and model (see [Location codes](#)). Is the failing SPCN card in the system unit?
  - ◆ **No:** Go to step 7.
  - ◆ **Yes:** Choose from the following:
    - ◇ If you are working on a model ESCALA PL 250R-VL or ESCALA PL 450R-XS, ESCALA PL 250R-L, PL 250R-L+ or PL 450R-VL+, ESCALA PL 450T/R, PL 450T/R+ or PL 850T/R-L+, 7/10, replace the system backplane (see [SYSBKPL](#)). **This ends the procedure.**
    - ◇ If you are working on a model 112/85, ESCALA PL 250T/R, PL 250T/R+ or PL 450T/R-L+, 165/615/70, or ESCALA PL 3250R, PL 3250R+, ESCALA PL 6450 or PL 6450R+, replace the service processor card (see [Finding part locations](#) to locate and replace the card) and then continue with the next step.
    - ◇ If you are working on a model 5/75, replace the system backplane (see [Locations model 5/75](#)). **This ends the procedure.**
6. Does the same reference code still occur?
  - ◆ **No:** **This ends the procedure.**
  - ◆ **Yes:** Replace the backplane (see [SYSBKPL](#)). **This ends the procedure.**
7. The failing SPCN card is in a secondary expansion unit or base I/O unit. Find the failing unit in the following table, and use the link to locations information to locate and replace the failing item.

**Attention:** For SRC 1xxx 8910 or 8920, ac removal is required to reset the flashing (frame-indicating) LEDs that are located on the TWRCARD.

| Expansion unit                                                                                              | Failing unit description                                                             | Symbolic FRU in locations table | Link to locations information                                               |
|-------------------------------------------------------------------------------------------------------------|--------------------------------------------------------------------------------------|---------------------------------|-----------------------------------------------------------------------------|
| 50/74, 8079-002, 8093-002                                                                                   | The SPCN card is part of the tower backplane assembly.                               | TWRCARD                         | <a href="#">Locations 50/74, 8079-002, and 8093-002 expansion I/O units</a> |
| 50/79                                                                                                       | The SPCN card is part of the tower backplane assembly.                               | TWRCARD                         | <a href="#">Locations 50/79 expansion I/O unit</a>                          |
| 50/88, 05/88(If the last 4 characters of word 1 are 7610, 7611, 7620, 7621, 7630, 7631, 7640, or 7641.)     | Replace the following one at a time:<br>a. AMD controller card<br>b. Tower backplane | a. AMDCTRL<br>b. TWRCARD        | <a href="#">Locations 50/88 and 05/88 expansion I/O units</a>               |
| 50/88, 05/88(If the last 4 characters of word 1 are not 7610, 7611, 7620, 7621, 7630, 7631, 7640, or 7641.) | The SPCN card is part of the tower backplane assembly.                               | TWRCARD                         | <a href="#">Locations 50/88 and 05/88 expansion I/O units</a>               |
| 50/94, 52/94, 8094-002                                                                                      | The SPCN card is part of the tower backplane assembly.                               | TWRCARD                         | <a href="#">Locations 50/94, 52/94, and 8094-002 expansion I/O units</a>    |
| 50/95, 05/95                                                                                                | The SPCN card is part of the tower backplane assembly.                               | TWRCARD                         | <a href="#">Locations 50/95 and 05/95 expansion I/O units</a>               |
| 11D/10, 11D/11, and 57/90                                                                                   | The SPCN card is part of the I/O backplane.                                          | TWRCARD                         | <a href="#">Locations 11D/10, 11D/11, and 57/90 expansion units</a>         |
| 11D/20                                                                                                      | The SPCN card is part of the I/O backplane.                                          | TWRCARD                         | <a href="#">Locations 11D/20 expansion unit</a>                             |
| Type 1519 xSeries server                                                                                    | Integrated xSeries adapter card (IXA)                                                |                                 | <a href="#">Locations Integrated xSeries adapter card (IXA)</a>             |

This ends the procedure.

Parent topic: [Symbolic FRUs](#)

---

## PWRSPLY

A power supply might be the failing item.

**Attention:** When replacing a redundant power supply, a 1xxx 1504, 1514, 1524, or 1534 reference code may surface in the error log. If you just removed and replaced the power supply in the location associated with this reference code, and the power supply came ready after the install, disregard this reference code. If you had not previously removed and replaced a power supply, the power supply did not come ready after installation, or there are repeated fan fault errors after the power supply replacement, continue to follow this procedure.



**Note:** Mixed voltage power supplies are not supported for models ESCALA PL 450T/R, PL 450T/R+ or PL 850T/R-L+ systems with redundant (2) power supplies installed. Depending on your redundant configuration, you must have 2 -100V ac supplies, 2- 200V ac supplies or 2- (-48)V dc supplies installed.

1. Is the reference code 1xxx-15xx?
  - ◆ **No:** Continue with substep 1.d.
  - ◆ **Yes:** Perform the following:
    - a. Find the unit reference code in one of the following tables to determine the failing power supply.
    - b. Ensure that the power cables are properly connected and seated.
    - c. Is the reference code 1xxx-1500, 1510, 1520, or 1530 and is the failing unit configured with a redundant power supply option (or dual line cord feature)?
      - **Yes:** Perform [PWR1911](#) before replacing parts.
      - **No:** Continue with step 1.d.
    - d. Refer to [Finding part locations](#) to determine the location and part number of the failing item
    - e. Replace the failing power supply (see the following tables to determine which power supply to replace).
    - f. Perform the following if the new power supply does not fix the problem:
      - i. Reinstall the original power supply.
      - ii. Try the new power supply in each of the other positions listed in the table.
      - iii. If the problem still is not fixed, reinstall the original power supply and go to the next FRU in the list.
      - iv. For reference codes 1xxx-1500, 1510, 1520, and 1530, exchange the power distribution backplane if a problem persists after replacing the power supply.

**Note:** If you are working on a Model ESCALA PL 450T/R and you have a reference code of 1xxx 1511 and/or 1521, but the system powered down or will not power up, you may have a power/processor interlock failure. Ensure the system power supply(s), processor(s), and processor filler are properly seated. If the system still will not power on, replace the following FRUs one at a time:

- a. Power supply 1 (for single-power-supply system only)
- b. Processor 2 (or processor filler)
- c. Processor 1
- d. System backplane
- e. Power supply 1
- f. Power supply 2

Table 1. Models 112/85, ESCALA PL 250R-VL or ESCALA PL 450R-XS, ESCALA PL 250R-L, PL 250R-L+ or PL 450R-VL+, ESCALA PL 250T/R, PL 250T/R+ or PL 450T/R-L+, ESCALA PL 450T/R, PL 450T/R+ or PL 850T/R-L+, ESCALA PL 1650R-L+, ESCALA PL 850R/PL 1650R/R+,

| Unit reference code                | Power supply |
|------------------------------------|--------------|
| 1510, 1511, 1512, 1513, 1514, 7110 | E1           |
| 1520, 1521, 1522, 1523, 1524, 7120 | E2           |

Table 2. Models 112/85, ESCALA PL 250T/R, PL 250T/R+ or PL 450T/R-L+ Quiet Office Acoustic Feature installed

| Unit reference code                | Power supply |
|------------------------------------|--------------|
| 1520, 1521, 1522, 1523, 1524, 7120 | E1           |

**Note:** 151x reference codes are not valid for the model the model ESCALA PL 250T/R, PL 250T/R+ or PL 450T/R-L+ with the Quiet Office Acoustic Feature installed.

**Attention:** For reference codes 1500, 1510, 1520, and 1530, perform [PWR1911](#) before replacing parts.

Table 3. 50/88, 05/88 expansion units

| Unit reference code                | Power supply |
|------------------------------------|--------------|
| 1510, 1511, 1512, 1513, 1514, 1516 | P02          |
| 1520, 1521, 1522, 1523, 1524, 1526 | P01          |

**Attention:** On a dual line cord system, for reference codes 1500, 1510, 1520, and 1530, perform [PWR1911](#) before replacing parts. On a single line cord system, check the ac jumper to the power supply before replacing parts.

Table 4. 50/74, 50/79, 50/94, 52/94 I/O expansion units (single line cord)

| Unit reference code                | Power supply |
|------------------------------------|--------------|
| 1510, 1511, 1512, 1513, 1514, 1516 | P01          |
| 1520, 1521, 1522, 1523, 1524, 1526 | P02          |
| 1530, 1531, 1532, 1533, 1534, 1536 | P03          |

**Attention:** On a dual line cord system, for reference codes 1500, 1510, 1520, and 1530, perform [PWR1911](#) before replacing parts. On a single line cord system, check the ac jumper to the power supply before replacing parts.

**Attention:** For 50/94, 52/94 expansion units, do not install power supplies P00 and P01 ac jumper cables on the same ac input module.

Table 5. 50/74, 50/79, 50/94, 52/94 I/O expansion units (dual line cord)

| Unit reference code | Power supply |
|---------------------|--------------|
|---------------------|--------------|

Service provider information

|                                    |     |
|------------------------------------|-----|
| 1500, 1501, 1502, 1503             | P00 |
| 1510, 1511, 1512, 1513, 1514, 1516 | P01 |
| 1520, 1521, 1522, 1523, 1524, 1526 | P02 |
| 1530, 1531, 1532, 1533             | P03 |

Table 6. 50/95, 05/95, 57/90, 11D/10, 11D/11, 11D/20, expansion units

| Unit reference code                      | Power supply |
|------------------------------------------|--------------|
| 1510, 1511, 1512, 1513, 1514, 1516, 1517 | P01/E1       |
| 1520, 1521, 1522, 1523, 1524, 1526, 1527 | P02/E2       |

**This ends the procedure.**

2. Is the reference code 1xxx-2600, 2601, 2603, 2605, or 2606?

- ◆ **No:** Continue with the next step.
- ◆ **Yes:** Perform the following:
  - a. Refer to [Finding part locations](#) to determine the location and part number of the failing item.
  - b. Replace the failing power supply.
  - c. Perform the following if the new power supply does not fix the problem:
    - i. Reinstall the original power supply.
    - ii. Try the new power supply in each of the other positions listed in the table.
    - iii. If the problem still is not fixed, reinstall the original power supply and go to the next FRU in the list.

**Attention:** Do not install power supplies P00 and P01 ac jumper cables on the same ac input module.

Table 7. Failing power supplies

| System or feature code                                                                                                                                                                                                                                 | Failing power supply |
|--------------------------------------------------------------------------------------------------------------------------------------------------------------------------------------------------------------------------------------------------------|----------------------|
| Models 112/85, ESCALA PL 250R-VL or ESCALA PL 450R-XS, ESCALA PL 250R-L, PL 250R-L+ or PL 450R-VL+, ESCALA PL 250T/R, PL 250T/R+ or PL 450T/R-L+, ESCALA PL 450T/R, PL 450T/R+ or PL 850T/R-L+, ESCALA PL 1650R-L+, ESCALA PL 850R/PL 1650R/R+, , 7/20 | Un-E1, Un-E2         |
| 50/74, 50/79, 50/94, 52/94 (single line cord)                                                                                                                                                                                                          | P01, P02, P03        |
| 50/74, 50/79, 50/94, 52/94 (dual line cord)                                                                                                                                                                                                            | P00, P01, P02, P03   |
| 50/88, 05/88                                                                                                                                                                                                                                           | P02, P01             |
| 50/95, 05/95                                                                                                                                                                                                                                           | P01, P02             |
| 57/90, 11D/10, 11D/11, 11D/20                                                                                                                                                                                                                          | E1, E2               |

**This ends the procedure.**

3. Is the reference code 1xxx 7300?

- ◆ **No:** Continue with the next step.
- ◆ **Yes:** Perform the following:
  - a. The failing power supply is either E1 or E2.
  - b. Refer to [Finding part locations](#) to determine the location and part number of the failing item.
  - c. Replace the failing power supply.

- d. Perform the following if the new power supply does not fix the problem:
  - i. Reinstall the original power supply.
  - ii. Try the new power supply in the other position.
  - iii. If the problem still is not fixed, reinstall the original power supply and go to the next FRU in the list.

**This ends the procedure.**

4. Is the reference code 1xxx 8455 or 8456?
  - ◆ **No:** Return to [Start of call procedure](#). **This ends the procedure.**
  - ◆ **Yes:** One of the power supplies is missing, and must be installed. Use the following table to determine which power supply is missing, and install the power supply (see [Finding part locations](#) to determine the part number and exchange procedure).

| Reference code | Missing power supply |
|----------------|----------------------|
| 1xxx 8455      | Un-E1                |
| 1xxx 8456      | Un-E2                |

**This ends the procedure.**

Parent topic: [Symbolic FRUs](#)

---

## Cannot perform IPL at a specified time (no SRC)

Use this procedure when you cannot perform an IPL at a specified time (no SRC). To correct the IPL problem, perform this procedure until you determine the problem and can perform an IPL at a specified time.

**DANGER**An electrical outlet that is not correctly wired could place hazardous voltage on the metal parts of the system or the devices that attach to the system. It is the responsibility of the customer to ensure that the outlet is correctly wired and grounded to prevent an electrical shock. (D004)

1. Verify the following:
  - a. The power cable is plugged into the power outlet.
  - b. That power is available at the customer's power outlet.
2. Power on the system in normal mode. See [Powering on and powering off](#).

Does the IPL complete successfully?

- ◆ Yes: Continue with the next step.
  - ◆ No: Go to the [Start of call procedure](#) procedure. This ends the procedure.
3. Have all the units in the system become powered on that you expected to become powered on?
    - ◆ Yes: Continue with the next step.
    - ◆ No: Go to [Start of call procedure](#) and find the symptom that matches the problem. This ends the procedure.
  4. Verify the requested system IPL date and time by doing the following:
    - a. On the command line, enter the Display System Value command:

```
DSPSYSVAL QIPLDATTIM
```

Observe the system value parameters.

**Note:** The system value parameters are the date and time the system operator requested a timed IPL.

Figure 1. Display for QIPLDATTIM

```

+-----+
|Display System Value
|System: S0000000
|System value . . . . . : QIPLDATTIM
|
|Description . . . . . : Date and time to automatically IPL
|
|IPL date . . . . . : MM/DD/YY
|IPL time . . . . . : HH:MM:SS
+-----+
    
```

b. Verify the system date. On the command line, enter the Display System Value command:

```
DSPSYSVAL QDATE
```

Check the system values for the date.

Figure 2. Display for QDATE

```

+-----+
|Display System Value
|System: S0000000
|System value . . . . . : QDATE
|
|Description . . . . . : System date
|
|Date . . . . . : MM/DD/YY
+-----+
    
```

Does the operating system have the correct date?

- ◇ Yes: Continue with this step.
- ◇ No: Set the correct date by doing the following:
  - i. On the command line, enter the Change System Value command  
(CHGSYSVAL QDATE VALUE('mmdyy')).
  - ii. Set the date by entering
    - mm=month
    - dd=day
    - yy=year
  - iii. Press Enter.

c. Verify the system time. On the command line, enter the Display System Value command:

```
DSPSYSVAL QTIME
```

Check the system values for the time.

Figure 3. Display for QTIME

```

+-----+
|Display System Value
|System: S0000000
|System value . . . . . : QTIME
|
|Description . . . . . : Time of day
|
|Time . . . . . : HH:MM:SS
+-----+
    
```

-----+  
 Does the operating system have the correct time?

- ◇ Yes: Continue with this step.
- ◇ No: Set the correct time by doing the following:
  - i. On the command line, enter the Change System Value command (CHGSYSVAL QTIME VALUE ('hhmmss')).
  - ii. Set the time by entering
    - hh=24 hour time clock
    - mm=minutes
    - ss=seconds
  - iii. Press Enter and continue with the next step.

5. Verify that the system can perform an IPL at a specified time by doing the following:

- a. Set the IPL time to 5 minutes past the present time by entering the Change System Value command (CHGSYSVAL SYSVAL(QIPLDATTIM) VALUE('mmddy hhmmss')) on the command line.
  - ◇ mm = month to power on
  - ◇ dd = day to power on
  - ◇ yy = year to power on
  - ◇ hh = hour to power on
  - ◇ mm = minute to power on
  - ◇ ss = second to power on
- b. Power off the system by entering the Power Down System Immediate command (PWRDWNSYS \*IMMED) on the command line.
- c. Wait 5 minutes.

Does the IPL start at the time you specified?

- ◇ No: Continue with the next step.
- ◇ Yes: This ends the procedure.

6. Power on the system in normal mode. See [Powering on and powering off](#).

Does the IPL complete successfully?

- ◆ Yes: Continue with the next step.
- ◆ No: Go to [Start of call procedure](#). This ends the procedure.

7. Find an entry in the Service Action Log that matches the time, SRC, and/or resource that compares to the reported problem.

- a. On the command line, enter the Start System Service Tools command:

```
STRSST
```

If you cannot get to SST, select DST. See [Dedicated Service Tools \(DST\)](#) for details.

**Note:** Do not IPL the system or partition to get to DST.

- b. On the Start Service Tools Sign On display, type in a user ID with service authority and password.
- c. Select Start a Service Tool > Hardware Service Manager > Work with service action log.
- d. On the Select Timeframe display, change the From: Date and Time to a date and time prior to when the customer reported having the problem.
- e. Find an entry that matches one or more conditions of the problem:
  - ◇ SRC
  - ◇ Resource
  - ◇ Time
  - ◇ FRU list (choose Display the failing item information to display the FRU list).

#### Notes:

- a. All entries in the service action log represent problems that require a service action. It may be necessary to handle any problem in the log even if it does not match the original problem symptom.

- b. The information displayed in the date and time fields are the time and date for the first occurrence of the specific system reference code (SRC) for the resource displayed during the time range selected.

Did you find an entry in the Service Action Log?

- ◆ No: Continue with the next step.
  - ◆ Yes: Go to step 9.
8. Exchange the following parts one at a time. See [Removing and replacing parts](#). After exchanging each part, return to step 5 to verify that the system can perform an IPL at a specified time.

**Note:** If you exchange the control panel or the system backplane, you must set the correct date and time by performing step 4.

**Attention:** Before exchanging any part, power off the system. See [Powering on and powering off](#).

- ◆ System unit backplane (see symbolic FRU [SYSBKPL](#)).
- ◆ System control panel
- ◆ System control panel cable

Did the IPL complete successfully after you exchanged all of the parts listed above?

- ◆ No: Contact your next level of support. This ends the procedure.
  - ◆ Yes: Continue with the next step.
9. Was the entry isolated (is there a Y in the Isolated column)?
- ◆ No: Go to the [List of system reference codes](#) and use the SRC indicated in the log. This ends the procedure.
  - ◆ Yes: Display the failing item information for the Service Action Log entry. Items at the top of the failing item list are more likely to fix the problem than items at the bottom of the list.

Exchange the failing items one at a time until the problem is repaired. After exchanging each one of the items, verify that the item exchanged repaired the problem.

**Notes:**

- a. For failing items see [Using failing item codes](#).
- b. For symbolic FRUs see [Symbolic FRUs](#).
- c. When exchanging FRUs, refer to the [Removing and replacing parts](#) procedures. If you are exchanging a disk unit, go to [Disk unit recovery procedures](#).
- d. After exchanging an item, go to [Verifying the repair](#).

After the problem has been resolved, close the log entry by selecting Close a NEW entry on the Service Actions Log Report display. This ends the procedure.

**Parent topic:** [IPL problems](#)

---

## SYSBKPL

The failing component is the system backplane.

After you have replaced the part, make sure to set the enclosure serial number before powering up, otherwise the machine will not IPL. For more information, see [Configuring I/O enclosures](#).

Use the table below to identify your machine type, model, and FRU, then click the associated link to find the service information for the specified FRU.

### For B1xx SRCs:

To determine which system backplane to replace on models ESCALA PL 1650R-L+ and ESCALA PL 850R/PL 1650R/R+, use the last byte in word 3 of the primary SRC.

- If the last byte is a 10, then replace the primary unit, I/O backplane.
- If the last byte is a 20, then replace the secondary unit 1, I/O backplane.
- If the last byte is a 30, use one of the following methods to determine which backplane to replace:

If you have access to the Advanced System Management Interface (ASMI), log on and display the details of the service processor error log. Using the Platform Event Log id (shown in the first table of each detail of the log), look at the first byte.

- ◆ If the first byte is a 50, then replace the primary unit, I/O backplane.
- ◆ If the first byte is a 51, then replace the secondary unit 1, I/O backplane.

If you have access to an Hardware Management Console (HMC), log in as PE user and bring up Manage Serviceable Events under the Service Focal Point screen. Display the events for the corresponding service processor system, then double-click the system to see the details. Look at the Field Platform log ID, which contains a decimal value that you need to convert to a hexadecimal value.

- ◆ If the first byte of the hexadecimal value is a 50, then replace the primary unit, I/O backplane.
- ◆ If the first byte of the hexadecimal value is a 51, then replace the secondary unit 1, I/O backplane.

Table 1. Backplane service information

| System model                                                  | Symbolic FRU to find | FRU to exchange                                                      | Link to locations information                                                                                        |
|---------------------------------------------------------------|----------------------|----------------------------------------------------------------------|----------------------------------------------------------------------------------------------------------------------|
| ESCALA PL 250T/R, PL 250T/R+ or PL 450T/R-L+                  | SYSBKPL              | System backplane                                                     | <a href="#">Locations</a> <a href="#">model</a><br>ESCALA PL 250T/R,<br>ESCALA PL 250T/R+ or<br>ESCALA PL 450T/R-L+  |
| ESCALA PL 250R-VL or<br>ESCALA PL 450R-XS                     | SYSBKPL              | System backplane                                                     | <a href="#">Locations</a> <a href="#">model</a><br>ESCALA PL 250R-VL or<br>ESCALA PL 450R-XS                         |
| ESCALA PL 250R-L, PL<br>250R-L+ or PL 450R-VL+                | SYSBKPL              | System backplane                                                     | <a href="#">Locations</a> <a href="#">model</a><br>ESCALA PL 250R-L,<br>ESCALA PL 250R-L+ or<br>ESCALA PL 450R-VL+,  |
| ESCALA PL 450T/R, PL<br>450T/R+ or PL 850T/R-L+               | SYSBKPL              | System backplane                                                     | <a href="#">Locations</a> <a href="#">model</a><br>ESCALA PL 450T/R,<br>ESCALA PL 450T/R+ or<br>ESCALA PL 850T/R-L+, |
| ESCALA PL 1650R-L+<br>and ESCALA PL 850R/PL<br>1650R/R+       | SYSBKPL              | Primary unit, I/O<br>backplane<br>Secondary unit<br>1, I/O backplane | <a href="#">Locations</a> <a href="#">model</a><br>ESCALA PL 1650R-L+<br>and ESCALA PL 850R/PL<br>1650R/R+           |
| 5/75                                                          | SYSBKPL              | System backplane                                                     | <a href="#">Locations</a> <a href="#">model</a> 5/75                                                                 |
| ESCALA PL 3250R, PL<br>3250R+, ESCALA PL<br>6450 or PL 6450R+ | SYSBKPL              | System backplane                                                     | <a href="#">Locations</a> <a href="#">model</a><br>ESCALA PL 3250R and<br>ESCALA PL 6450R                            |



Parent topic: [Symbolic FRUs](#)

## Cannot automatically perform an IPL after a power failure

Use this procedure when you cannot automatically perform an IPL after a power failure.

1. Normal or Auto mode on the control panel must be selected when power is returned to the system.

Is Normal or Auto mode on the control panel selected?

- ◆ Yes: Continue with the next step.
- ◆ No: Select Normal or Auto mode on the control panel. This ends the procedure.

2. Use the Display System Value command (`DSPSYSVAL`) to verify that the system value under QPWRRTIPL on the Display System Value display is equal to 1.

Is QPWRRTIPL equal to 1?

- ◆ Yes: Continue with the next step.
- ◆ No: Use the Change System Value command (`CHGSYSVAL`) to set QPWRRTIPL equal to 1. This ends the procedure.

3. For Models ESCALA PL 250T/R and ESCALA PL 850R/PL 1650R/R+, exchange the Tower card. See symbolic FRU [TWRCARD](#). Refer to [Removing and replacing parts](#) for the model you are working on. Also, before exchanging any part, power off the system. See [Powering on and powering off](#).

**Note:** If you exchange the tower card or the system unit backplane, you must set the system date (QDATE) and time (QTIME). This ends the procedure.

Parent topic: [IPL problems](#)

## Power problems

Use the following table to find out how to begin analyzing a power problem.

Table 1. Analyzing power problems

| Symptom                                                                                                                                                                                                                                                                                                                                                                                                                                                                                                                                                                                         | What you should do                                                                                                                                    |
|-------------------------------------------------------------------------------------------------------------------------------------------------------------------------------------------------------------------------------------------------------------------------------------------------------------------------------------------------------------------------------------------------------------------------------------------------------------------------------------------------------------------------------------------------------------------------------------------------|-------------------------------------------------------------------------------------------------------------------------------------------------------|
| <p>There may or may not be a reference code displayed on the control panel, the Hardware Management Console (HMC, or on the Advanced System Management Interface (ASMI).</p> <p>Perform the following steps to check the HMC for codes:</p> <ol style="list-style-type: none"> <li>1. In the Navigation Area, expand Server and Partition &gt; Server Management.</li> <li>2. In the right pane, expand or select your system or partition. View the associated value in the Operator Panel Value column.</li> </ol> <p>To check the ASMI for codes, select Error/Event Logs from the menu.</p> | <p>Record the reference code shown. Go to <a href="#">(1xxx) System power control network (SPCN) reference codes</a> and find the reference code.</p> |
| System unit does not power on.                                                                                                                                                                                                                                                                                                                                                                                                                                                                                                                                                                  | See <a href="#">Cannot power on system unit</a> .                                                                                                     |
| The system or expansion unit does not power off.                                                                                                                                                                                                                                                                                                                                                                                                                                                                                                                                                | See <a href="#">Cannot power off system or SPCN-controlled I/O expansion unit</a> .                                                                   |

|                                                                                                                                     |                                                                          |
|-------------------------------------------------------------------------------------------------------------------------------------|--------------------------------------------------------------------------|
| The system does not remain powered on during a loss of incoming ac voltage and has an Uninterruptible Power Supply (UPS) installed. | Refer to the UPS user's guide that came with your unit.                  |
| An I/O expansion unit does not power on.                                                                                            | See <a href="#">Cannot power on SPCN-controlled I/O expansion unit</a> . |

## Cannot power on system unit

Perform this procedure until you correct the problem and you can power on the system.

### **DANGER**When working on or around the system, observe the following precautions:

Electrical voltage and current from power, telephone, and communication cables are hazardous. To avoid a shock hazard:

- Connect power to this unit only with the provided power cord. Do not use the provided power cord for any other product.
- Do not open or service any power supply assembly.
- Do not connect or disconnect any cables or perform installation, maintenance, or reconfiguration of this product during an electrical storm.
- The product might be equipped with multiple power cords. To remove all hazardous voltages, disconnect all power cords.
- Connect all power cords to a properly wired and grounded electrical outlet. Ensure that the outlet supplies proper voltage and phase rotation according to the system rating plate.
- Connect any equipment that will be attached to this product to properly wired outlets.
- When possible, use one hand only to connect or disconnect signal cables.
- Never turn on any equipment when there is evidence of fire, water, or structural damage.
- Disconnect the attached power cords, telecommunications systems, networks, and modems before you open the device covers, unless instructed otherwise in the installation and configuration procedures.
- Connect and disconnect cables as described in the following procedures when installing, moving, or opening covers on this product or attached devices.

To Disconnect:

1. Turn off everything (unless instructed otherwise).
2. Remove the power cords from the outlets.
3. Remove the signal cables from the connectors.
4. Remove all cables from the devices

To Connect:

1. Turn off everything (unless instructed otherwise).
2. Attach all cables to the devices.
3. Attach the signal cables to the connectors.
4. Attach the power cords to the outlets.
5. Turn on the devices.

(D005)

1. Are you working with a model 5/75, ESCALA PL 3250R, or ESCALA PL 6450R
  - ◆ No: Continue with the next step.
  - ◆ Yes: Go to [PWR1912](#). This ends the procedure.
2. Attempt to power on the system (see [Powering on and powering off](#)). Does the system power on, and is the system power status indicator light on continuously?

**Note:** The system power status indicator blinks at the slower rate (one blink per two seconds) while powered off, and at the faster rate (one blink per second) during a normal power-on sequence.

- ◆ No: Continue with the next step.
  - ◆ Yes: Go to step [16](#).
3. Are there any characters displayed on the control panel (a scrolling dot may be visible as a character)?
- ◆ No: Continue with the next step.
  - ◆ Yes: Go to step [6](#).
4. Are the mainline ac power cables from the power supply, power distribution unit, or external uninterruptible power supply (UPS) to the customer's ac power outlet connected and seated correctly at both ends?
- ◆ Yes: Continue with the next step.
  - ◆ No: Connect the mainline ac power cables correctly at both ends and go to step [2](#).
5. Perform the following:
- a. Verify that the UPS is powered on (if it is installed). If the UPS will not power on, follow the service procedures for the UPS to ensure proper line voltage and UPS operation.
  - b. Disconnect the mainline ac power cable or ac power jumper cable from the system's ac power connector at the system.
  - c. Use a multimeter to measure the ac voltage at the system end of the mainline ac power cable or ac power jumper cable.

**Note:** Some system models have more than one mainline ac power cable or ac power jumper cable. For these models, disconnect all the mainline ac power cables or ac power jumper cables and measure the ac voltage at each cable before continuing with the next step.

Is the ac voltage from 200 V ac to 240 V ac, or from 100 V ac to 127 V ac?

- ◇ No: Go to step [9](#).
  - ◇ Yes: Continue with the next step.
6. Perform the following:
- a. Disconnect the mainline ac power cable(s) from the power outlet.
  - b. Exchange the system unit control panel (see symbolic FRU [CTLPNL](#)).
  - c. Reconnect the mainline ac power cables to the power outlet.
  - d. Attempt to power on the system.
- Does the system power on?
- ◆ No: Continue with the next step.
  - ◆ Yes: The system unit control panel was the failing item. This ends the procedure.
7. Perform the following:
- a. Disconnect the mainline ac power cable(s) from the power outlet.
  - b. Exchange the power supply or supplies (see [Finding part locations](#)).
  - c. Reconnect the mainline ac power cables to the power outlet.
  - d. Attempt to power on the system.
- Does the system power on?
- ◆ No: Continue with the next step.
  - ◆ Yes: The power supply was the failing item. This ends the procedure.
8. Perform the following:
- a. Disconnect the mainline ac power cable(s).
  - b. Exchange the SPCN card. See symbolic FRU [TWRCARD](#).
  - c. Reconnect the mainline ac power cables to the power outlet.
  - d. Attempt to power on the system.
- Does the system power on?
- ◆ No: Call your next level of assistance. This ends the procedure.
  - ◆ Yes: The SPCN card was the failing item. This ends the procedure.
9. Are you working on a system unit with a power distribution unit with tripped breakers?
- ◆ No: Continue with the next step.
  - ◆ Yes: Perform the following:
    - a. Reset the tripped power distribution breaker.

- b. Verify that the removable ac power cable is not the problem. Replace the cord, as installed, if it is defective.
  - c. If the breaker continues to trip, install a new power supply (as installed) in each location until the defective one is found. This ends the procedure.
10. Does the system have an external UPS installed?
- ◆ Yes: Continue with the next step.
  - ◆ No: Go to step 12.
11. Use a multimeter to measure the ac voltage at the external UPS outlets. Is the ac voltage from 200 V ac to 240 V ac or from 100 V ac to 127 V ac?
- ◆ No: The UPS needs service. For 9910 type UPS, call Service Support. For all other UPS types, have the customer call the UPS provider. In the meantime, go to step 13 to bypass the UPS.
  - ◆ Yes: Exchange the ac power cable, as installed (see the [Part number catalog](#)). This ends the procedure.
12. Perform the following:
- a. Disconnect the mainline ac power cable from the customer's ac power outlet.
  - b. Use a multimeter to measure the ac voltage at the customer's ac power outlet.

**Note:** Some system models have more than one mainline ac power cable. For these models, disconnect all the mainline ac power cables and measure the ac voltage at all ac power outlets before continuing with this step.

Is the ac voltage from 200 V ac to 240 V ac, or from 100 V ac to 127 V ac?

- ◇ Yes: Exchange the mainline ac power cable. See the [Part number catalog](#). Then go to step 2.
- ◇ No: Inform the customer that the ac voltage at the power outlet is not correct. When the ac voltage at the power outlet is correct, reconnect the mainline ac power cables to the power outlet. This ends the procedure.

13. Perform the following to bypass the UPS unit:
- a. Power off your system and the UPS unit.
  - b. Remove the signal cable (see [Part number catalog](#)) used between the UPS and the system.
  - c. Remove any power jumper cords used between the UPS and the attached devices.
  - d. Remove the country or region specific power cord used from the UPS to the wall outlet.
  - e. Use the correct power cord (the original country or region specific power cord shipped with your system) and connect it to the power inlet on the system. Plug the other end of this cord into a compatible wall outlet.
  - f. Attempt to power on the system.
- Does the power-on standby sequence complete successfully?

- ◆ Yes: Go to [Verifying the repair](#). This ends the procedure.
- ◆ No: Go to step 6.

14. Display the selected IPL mode on the system unit control panel (see [IPL information](#) in the [Service functions](#)). Is the selected mode the same mode that the customer was using when the power-on failure occurred?

- ◆ No: Go to step 16.
- ◆ Yes: Continue with the next step.

15. Is a function 11 reference code displayed on the system unit control panel?

- ◆ No: Go to step 17.
- ◆ Yes: Return to [Start of call procedure](#). This ends the procedure.

16. Perform the following:

- a. Power off the system.
- b. Select the mode on the system unit control panel that the customer was using when the power-on failure occurred.
- c. Attempt to power on the system.

Does the system power on?

- ◆ Yes: Continue with the next step.
- ◆ No: Exchange the system unit control panel. See symbolic FRU [CTLPNL](#). This ends the procedure.

17. Continue the IPL. Does the IPL complete successfully?

- ◆ Yes: This ends the procedure.
- ◆ No: Return to [Start of call procedure](#). This ends the procedure.

## PWR1912

The server detected an error in the power system.

### **DANGER**When working on or around the system, observe the following precautions:

Electrical voltage and current from power, telephone, and communication cables are hazardous. To avoid a shock hazard:

- Connect power to this unit only with the provided power cord. Do not use the provided power cord for any other product.
- Do not open or service any power supply assembly.
- Do not connect or disconnect any cables or perform installation, maintenance, or reconfiguration of this product during an electrical storm.
- The product might be equipped with multiple power cords. To remove all hazardous voltages, disconnect all power cords.
- Connect all power cords to a properly wired and grounded electrical outlet. Ensure that the outlet supplies proper voltage and phase rotation according to the system rating plate.
- Connect any equipment that will be attached to this product to properly wired outlets.
- When possible, use one hand only to connect or disconnect signal cables.
- Never turn on any equipment when there is evidence of fire, water, or structural damage.
- Disconnect the attached power cords, telecommunications systems, networks, and modems before you open the device covers, unless instructed otherwise in the installation and configuration procedures.
- Connect and disconnect cables as described in the following procedures when installing, moving, or opening covers on this product or attached devices.

To Disconnect:

1. Turn off everything (unless instructed otherwise).
2. Remove the power cords from the outlets.
3. Remove the signal cables from the connectors.
4. Remove all cables from the devices

To Connect:

1. Turn off everything (unless instructed otherwise).
2. Attach all cables to the devices.
3. Attach the signal cables to the connectors.
4. Attach the power cords to the outlets.
5. Turn on the devices.

(D005)

1. Perform the following:
  - a. Ensure that both power line cords are properly connected.
  - b. Make sure that the unit EPO switch is in the *on* position.
  - c. Make sure that the unit EPO bypass switches on both bulk power controllers (BPCs) are in the *normal* position.
  - d. Ensure that the cable from unit EPO connector J00 to BPC-A connector J05 and the cable from unit EPO connector J01 to BPC-B connector J05 are secure and undamaged.
  - e. Ensure that the room temperature is not in excess of the maximum allowed (40° Celsius or 104° Fahrenheit).

**Note:** If the room temperature has exceeded the maximum allowed, the system may continually cycle on and off.

Were any problems discovered while performing the above checks?

- ◆ **No:** Continue with the next step.
  - ◆ **Yes:** Correct any problems you found. **This ends the procedure.**
2. Make sure that the on/off switches on all the bulk power regulators (BPRs) are in the *on* (left) position.

**Note:** A switch set to the *off* position is not the cause of your problem, but they all need to be on before proceeding.

3. Check the state of the LEDs on both sides of the bulk power assembly (BPA) and then choose from the following conditions:
- ◆ If all of the LEDs on both sides of the BPA are in the *off* position, go to step 4.
  - ◆ If the unit EPO power LED is turned on, the BPC **GOOD** LED is turned on, and all other LEDs are in the *off* position, go to step 5.
  - ◆ If neither of the above two conditions is true, independent faults are indicated on both sides of the BPA. Each side must be isolated separately. Call your next level of support. **This ends the procedure.**
4. Prepare a voltage meter to measure up to 600 V ac. Using the labelled test points on the frame, measure the voltage between phase A and phase B. Is the voltage greater than 180 V ac?
- ◆ **Yes:** Independent faults are indicated on both sides of the BPA. Each side must be isolated separately. Call your next level of support. **This ends the procedure.**
  - ◆ **No:** Inform the customer that power line voltage at the input to the BPR is missing or too low and needs to be corrected. **This ends the procedure.**
5. Is a cable connected to connector J02 on the unit EPO card?
- ◆ **No:** Continue with the next step.
  - ◆ **Yes:** Go to step 7 to determine if the room EPO circuit is the problem.
6. Is the internal toggle switch on the unit EPO card set to the *RM EPO BYPASS* position?
- ◆ **No:** Set the internal toggle switch on the unit EPO card to the *RM EPO BYPASS* position. **This ends the procedure.**
  - ◆ **Yes:** The unit EPO card is the failing item. Go to [Locations model ESCALA PL 3250R and ESCALA PL 6450R](#) or [Locations model 5/75](#) to locate and replace the card. **This ends the procedure.**
7. Unplug the cable from connector J02 on the EPO card and set the toggle switch to the *RM EPO BYPASS* position. Does the EPO **CMPLT** LED on at least one BPC become lit?
- ◆ **Yes:** Inform the customer that the room EPO circuit is defective at this connection and requires service. **This ends the procedure.**
  - ◆ **No:** The unit EPO card is the failing item. Go to [Locations model ESCALA PL 3250R and ESCALA PL 6450R](#) or [Locations model 5/75](#) to locate and replace the card. **This ends the procedure.**

Parent topic: [Power isolation procedures](#)

---

## CTLPNL

A control panel or display panel may be failing.

Go to [Finding part locations](#) to locate and exchange the control or display panel on the system or expansion unit you are working with.

Parent topic: [Symbolic FRUs](#)

---

## Part number catalog

Use this information to find part numbers of common hardware parts.

This catalog contains only the part numbers likely to be needed during hardware servicing, and is not a complete part number listing.

- **Part assembly diagrams**

Use this information to view diagrams of various hardware part assemblies.

- **System parts**  
Use this information to find part numbers for parts that have CCIN or Failing Function Code numbers.
- **Cables**  
Use this parts listing to find internal power and signal cables and external cables.
- **Miscellaneous parts**  
Use this information to find part numbers for miscellaneous items such as keyboards, cable wraps, or cleaning kits.
- **Hardware Management Console (HMC) parts**  
Use this information to find part numbers for HMC.

Parent topic: [Locating and exchanging parts](#)

---

## Part assembly diagrams

Use this information to view diagrams of various hardware part assemblies.

The part assembly diagrams contain mechanical and connecting parts. See the following for other parts:

- For parts that have CCINs, servers Failing Function Code numbers, or o/p Failing Function Code numbers, see [System parts](#).
- For internal signal and power cables and external cables, see [Cables](#).
- For miscellaneous parts such as cable wraps or cleaning kits, see [Miscellaneous parts](#).
- For Hardware Management Console (HMC) parts, see [Hardware Management Console \(HMC\) parts](#).

For more details, see [How to use this parts listing](#).

- **How to use the part assembly diagrams**  
Use this information to understand how to use the abbreviations in the part assembly diagrams.
- **Part assembly diagrams for model ESCALA PL 245T/R**
- **Part assembly diagrams for model ESCALA PL 250R-VL or ESCALA PL 450R-XS**
- **Part assembly diagrams for model ESCALA PL 250R-L, PL 250R-L+ or PL 450R-VL+**
- **Part assembly diagrams for model ESCALA PL 250T/R, PL 250T/R+ or PL 450T/R-L+**  
This content covers the 112/85, ESCALA PL 250T/R+ or ESCALA PL 450T/R-L+, 9405-520, 9406-520, and ESCALA PL 250T/R models.
- **Part assembly diagrams for model ESCALA PL 450T/R, PL 450T/R+ or PL 850T/R-L+**
- **Part assembly diagrams for model ESCALA PL 1650R-L+ and ESCALA PL 850R/PL 1650R/R+**
- **Part assembly diagrams for model 5/75**
- **Part assembly diagrams for ESCALA PL 3250R, PL 3250R+, ESCALA PL 6450 or PL 6450R+ and 5792 racks**
- **Part assembly diagrams for , 05/88, 50/79, 50/88, and 52/94 expansion units**
- **Part assembly diagrams for 50/74, 50/94, 82/94, and 91/94 expansion units**
- **Part assembly diagrams for 05/95 and 50/95 expansion units**
- **Part assembly diagrams for 57/86, 57/87, D24, and T24 expansion units**
- **Part assembly diagrams for 57/91 and 57/94 expansion units**
- **Part assembly diagrams for 57/95 expansion unit**
- **Part assembly diagrams for 11D/11 and 57/90 expansion units**
- **Part assembly diagrams for 11D/20 expansion unit**
- **Part assembly diagrams for 0553, 14T/00, and 14T/42 racks**
- **Part assembly diagrams for 05/54 and 14S/11 racks**
- **Part assembly diagrams for 05/55 and 14S/25 racks**

Parent topic: [Part number catalog](#)

---

## How to use the part assembly diagrams

Use this information to understand how to use the abbreviations in the part assembly diagrams.

- If two assemblies contain a majority of identical parts, they are on the same list. Common parts are shown by one index number. Parts specific to one or the other of the assemblies are listed separately and identified by description.
- **AR** (as required) in the **Units** column indicates that the quantity is not the same for all machines.
- **NP** (non-procurable) in the **Units** column indicates that the part is non-procurable and that the individual parts or the next higher assembly should be ordered.
- **NR** (not recommended) in the **Units** column indicates that the part is procurable but not recommended for field replacement and that the next higher assembly should be ordered.
- **R** (restricted) in the **Units** column indicates that the part has a restricted availability.
- **NONUM** (no number) indicates that the part number is not available.
- **REF** (reference) indicates that the part is shown for reference and may be listed more than once.
- Indenture is marked by a series of dots located before the parts description. The indenture indicates the relationship of a part to the next higher assembly. For example:

| Indenture | Relationship of parts                                                 |
|-----------|-----------------------------------------------------------------------|
| No dots   | Main assembly                                                         |
| One dot   | Subassembly of the main assembly or detail parts of the main assembly |

Parent topic: [Part assembly diagrams](#)

## Part assembly diagrams for model ESCALA PL 250R-L, PL 250R-L+ or PL 450R-VL+

This content covers the ESCALA PL 250R-L, ESCALA PL 250R-L+ or ESCALA PL 450R-VL+, models.

### Final assembly

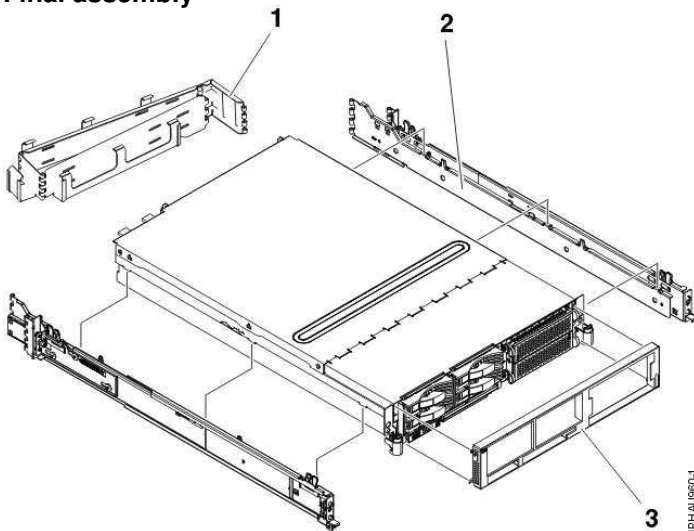


Table 1. Final assembly part numbers

| Index number | Part number | Units per assembly | Description |
|--------------|-------------|--------------------|-------------|
| 2            | 90P4069     | 1                  | Rail kit    |



|   |         |   |       |
|---|---------|---|-------|
| 3 | 97P6799 | 1 | Cover |
|---|---------|---|-------|

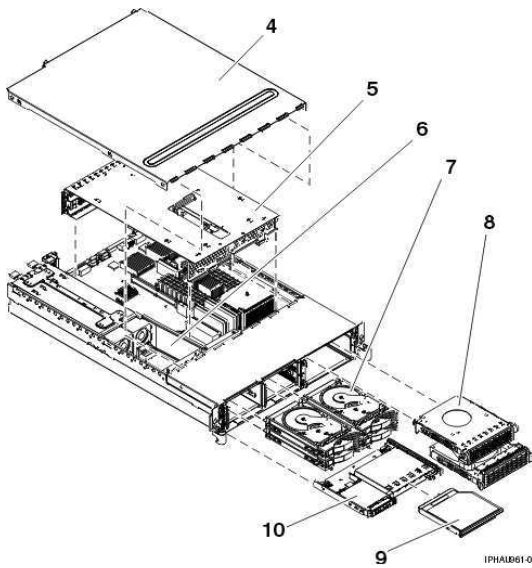


Table 2. Final assembly part numbers

| Index number | Part number                                      | Units per assembly | Description                                     |
|--------------|--------------------------------------------------|--------------------|-------------------------------------------------|
| 4            | 97P5817                                          | 1                  | Top cover                                       |
| 5            | See <a href="#">Backplane parts</a>              | 1                  | Enclosure, PCI adapter                          |
|              | See <a href="#">System parts</a>                 | AR                 | PCI adapter                                     |
| 6            | 97P6880                                          | 1                  | Air dam                                         |
| 7            | See <a href="#">Disk unit parts</a>              | AR                 | Disk unit                                       |
|              | 97P4179                                          | AR                 | Filler, disk unit                               |
| 8            | 97P5819                                          | 2                  | Fan                                             |
|              | 97P6840                                          | 2                  | Cable, fan                                      |
| 9            | See <a href="#">Removable media device parts</a> | AR                 | Removable media                                 |
|              | 53P5867                                          | AR                 | Filler, removable media                         |
| 10           | See <a href="#">Control panel parts</a>          | 1                  | Control panel and removable media tray assembly |

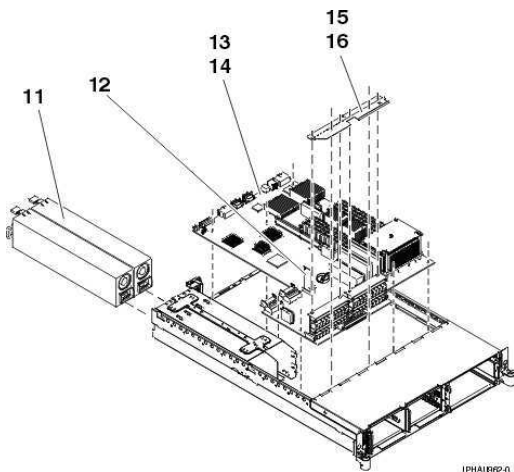


Table 3. Final assembly part numbers

| Index number | Part number                         | Units per assembly | Description             |
|--------------|-------------------------------------|--------------------|-------------------------|
| 11           | See <a href="#">Power parts</a>     | AR                 | Power supply            |
|              | 39J0534                             | AR                 | Filler, power supply    |
| 12           | See <a href="#">VPD parts</a>       | 1                  | VPD card                |
| 13           | See <a href="#">Backplane parts</a> | 1                  | System backplane        |
| 14           | 39J0199                             | AR                 | Screw, system backplane |
| 15           | NONUM                               | 1                  | Bracket, support        |
| 16           | 30J0200                             | AR                 | Screw, support bracket  |
|              | See <a href="#">Memory parts</a>    | AR                 | Memory card             |
|              | 44H8167                             | AR                 | Filler, memory card     |
|              | See <a href="#">Power parts</a>     |                    | Voltage regulator, 1.3  |
|              | See <a href="#">Power parts</a>     |                    | Voltage regulator, 2.5  |
|              | See <a href="#">Power parts</a>     |                    | Battery                 |

Parent topic: [Part assembly diagrams](#)

## Part assembly diagrams for model 5/75

This content covers the model 185/75.

### Final assembly for model 5/75

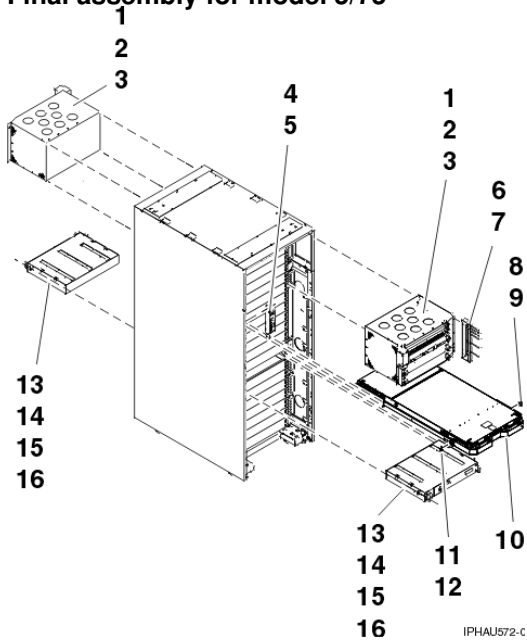


Table 1. Final assembly part numbers for model 5/75

| Part number | Units per assembly | Description |
|-------------|--------------------|-------------|
|-------------|--------------------|-------------|

| Index number |         |    |                                                                                                                |
|--------------|---------|----|----------------------------------------------------------------------------------------------------------------|
| 1            | 12R9749 | 1  | Bulk power assembly. For a detailed parts list see the <a href="#">Bulk power assembly (BPA)</a> .             |
| 2            | 77G0599 | 2  | Screw, BPE mounting                                                                                            |
| 3            | 74F1823 | 5  | Nut clip                                                                                                       |
| 4            | 15R6747 | 1  | Unit emergency power off (UEPO) switch assembly                                                                |
| 5            | 2665528 | 2  | Screw, UEPO mounting                                                                                           |
| 6            | 11P3843 | 1  | Cable bracket                                                                                                  |
| 7            | 77G0599 | 3  | Screw, cable bracket                                                                                           |
| 8            | 12R9758 | 1  | Mount, right                                                                                                   |
| 9            | 77G0599 | 2  | Screw                                                                                                          |
| 10           | NONUM   | AR | Processor subsystem assembly. For a detailed parts list see the <a href="#">Processor subsystem assembly</a> . |
| 11           | 12R9757 | 1  | Mount, left                                                                                                    |
| 12           | 77G0599 | 2  | Screw                                                                                                          |
| 13           | 41U0012 | AR | Internal battery feature (IBF)                                                                                 |
| 14           | 77G0599 | 2  | Screw                                                                                                          |
| 15           | 5589089 | 2  | Washer                                                                                                         |
| 16           | 74F1823 | 2  | Nut clip                                                                                                       |

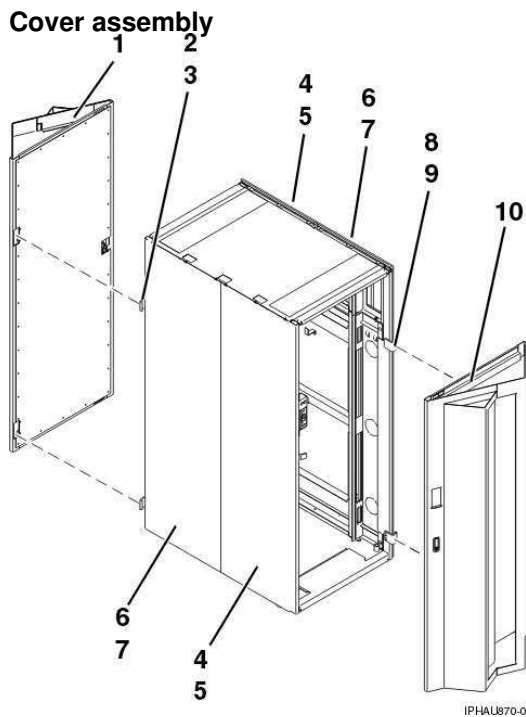


Table 2. Cover assembly part numbers

| Index number | Part number | Units per assembly | Description |
|--------------|-------------|--------------------|-------------|
|--------------|-------------|--------------------|-------------|

Service provider information

|         |                    |               |                        |
|---------|--------------------|---------------|------------------------|
| 44P2670 | AR                 | Filter, cover |                        |
| 1       | 41U0395            |               | Cover kit (acoustical) |
| 2       | 11P4106            | 2             | Hinge, back cover      |
| 3       | 2665525            | 4             | Screw, hinge           |
| 4       | 44P0126            | 2             | Cover, right-side      |
| 5       | 54G2882            | 3             | Screw, cover mounting  |
| 6       | 44P0125            | 2             | Cover, left-side       |
| 7       | 54G2882            | 3             | Screw, cover mounting  |
| 8       | 11P3535            | 2             | Hinge, front cover     |
| 9       | 2665525            | 4             | Screw, hinge           |
| 10      | See index number 1 | 1             | Cover kit              |

**Bulk power assembly (BPA)**

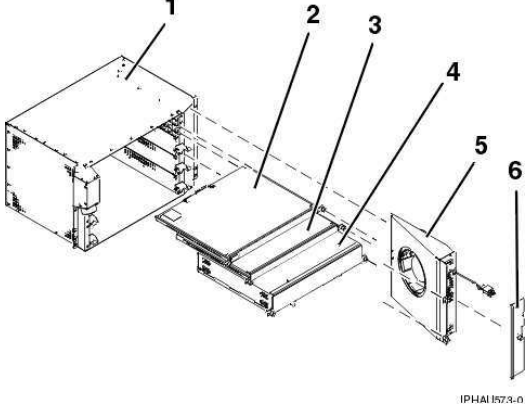


Table 3. Bulk power assembly (BPA) part numbers

| Index number | Part number                     | Units per assembly | Description                      |
|--------------|---------------------------------|--------------------|----------------------------------|
| 1            | 12R9749                         | 1                  | Bulk power assembly              |
| 2            | See <a href="#">Power parts</a> | AR                 | Bulk power jumper                |
|              | See <a href="#">Power parts</a> | AR                 | Bulk power hub                   |
|              | See <a href="#">Power parts</a> | AR                 | Bulk power distribution assembly |
| 3            | See <a href="#">Power parts</a> | AR                 | Bulk power controller assembly   |
| 4            | See <a href="#">Power parts</a> | AR                 | Bulk power regulator assembly    |
| 5            | See <a href="#">Power parts</a> | 1                  | Bulk power fan                   |
| 6            | 44P0550                         | 1                  | Cover, bulk power fan            |

**Processor subsystem assembly**

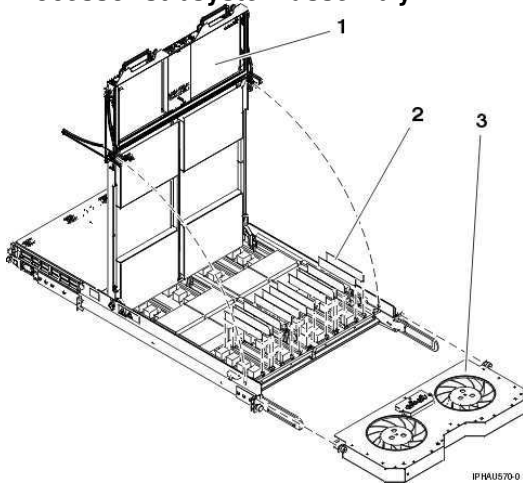


Table 4. Processor subsystem assembly part numbers

| Index number | Part number                      | Units per assembly | Description           |
|--------------|----------------------------------|--------------------|-----------------------|
| 1            | See <a href="#">Power parts</a>  | 1                  | Power supply assembly |
| 2            | See <a href="#">Memory parts</a> | AR                 | Memory card           |
|              | 44H8167                          | AR                 | Filler, memory card   |
| 3            | 12R9901                          | 1                  | Fan assembly          |

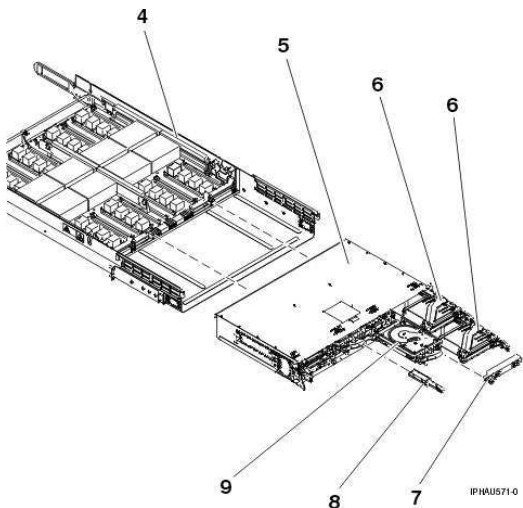


Table 5. Processor subsystem assembly part numbers, continued

| Index number | Part number                         | Units per assembly | Description                            |
|--------------|-------------------------------------|--------------------|----------------------------------------|
| 4            | See <a href="#">Backplane parts</a> | 1                  | Processor subsystem assembly backplane |
| 5            | See <a href="#">Backplane parts</a> | 1                  | I/O assembly                           |
| 6            |                                     | AR                 | PCI adapter                            |

|   |                                     |    |                      |
|---|-------------------------------------|----|----------------------|
|   | See <a href="#">System parts</a>    |    |                      |
|   | 16R0091                             | AR | PCI adapter cassette |
| 6 | See <a href="#">System parts</a>    | AR | GX card              |
| 7 | 16R0802                             | AR | Filler, GX card      |
| 8 | See <a href="#">VPD parts</a>       | 1  | VPD card             |
| 9 | See <a href="#">Disk unit parts</a> | 2  | Disk drive           |

Parent topic: [Part assembly diagrams](#)

## Part assembly diagrams for 57/91 and 57/94 expansion units

Final assembly

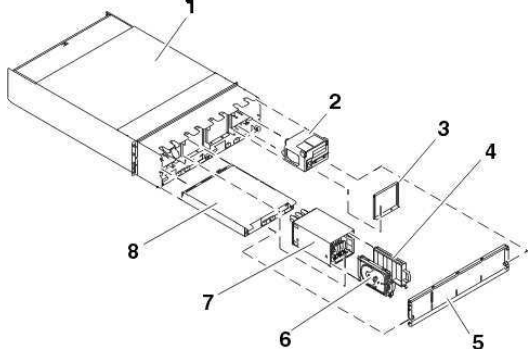


Table 1. Final assembly (front) part numbers

| Index number | Part number                         | Units per assembly | Description                                |
|--------------|-------------------------------------|--------------------|--------------------------------------------|
| 1            | 41V0453                             | 1                  | Chassis                                    |
|              | 07H5247                             | 2                  | Frame rail                                 |
| 2            | 12R9234                             | AR                 | Fan assembly                               |
| 3            | 44P1277                             | AR                 | Disk drive enclosure filler                |
| 4            | 11P3662                             | AR                 | Disk drive filler                          |
| 5            | 44P0189                             | 1                  | Front cover                                |
| 6            | See <a href="#">Disk unit parts</a> | AR                 | Disk drive                                 |
| 7            | 41V0608                             | AR                 | Disk unit enclosure and backplane assembly |
|              | 41V1064                             |                    | Screw                                      |
|              | 11P3457                             |                    | Screw                                      |
|              | 11P3667                             |                    | Screw                                      |
| 8            | 16R1060                             | 2                  | Power supply                               |

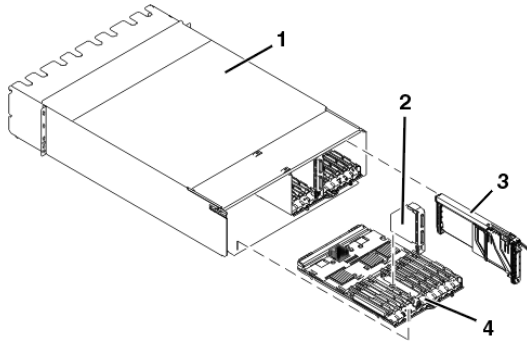


Table 2. Final assembly (back) part numbers

| Index number | Part number                         | Units per assembly | Description                                                    |
|--------------|-------------------------------------|--------------------|----------------------------------------------------------------|
| 1            | 41V0453                             | 1                  | Chassis                                                        |
| 2            | NONUM                               | AR                 | RIO riser card, part of the I/O backplane (see index number 4) |
| 3            | 44P1055                             | AR                 | PCI adapter cassette assembly                                  |
|              | 44P1390                             | AR                 | PCI adapter cassette assembly - double wide                    |
|              | 11P4089                             | AR                 | PCI adapter cassette filler                                    |
| 4            | See <a href="#">Backplane parts</a> | AR                 | I/O backplane                                                  |

Parent topic: [Part assembly diagrams](#)

## Part assembly diagrams for 57/95 expansion unit

### Final assembly

Table 1. Final assembly part numbers

| Index number | Part number                                      | Units per assembly | Description                   |
|--------------|--------------------------------------------------|--------------------|-------------------------------|
|              | 11P4616                                          | 2                  | Rail                          |
|              | 54G2882                                          | 4                  | Screw, rail                   |
|              | 11P2445                                          | 2                  | Clamp, rail                   |
|              | 54G2882                                          | 4                  | Screw, rail clamp             |
|              | 12R8040                                          | 1                  | Filler, control panel         |
|              | 12R8041                                          | 1                  | Filler, diskette              |
|              | See <a href="#">Removable media device parts</a> | AR                 | Media device                  |
|              | 11P2444                                          | 1                  | Filler, media device          |
|              | 21L3165                                          | AR                 | Screw, media device           |
|              | 07H6655                                          | AR                 | Cable tie                     |
|              | NONUM                                            | 1                  | Cover assembly                |
|              | 84X4841                                          | 8                  | Screw, M4 cover assembly      |
|              | 32G1536                                          | 8                  | Screw, M4 Torx cover assembly |

Parent topic: [Part assembly diagrams](#)

## Part assembly diagrams for 0553, 14T/00, and 14T/42 racks

### Frames, side panels, and top cover assembly for 14T/00 and 14T/42

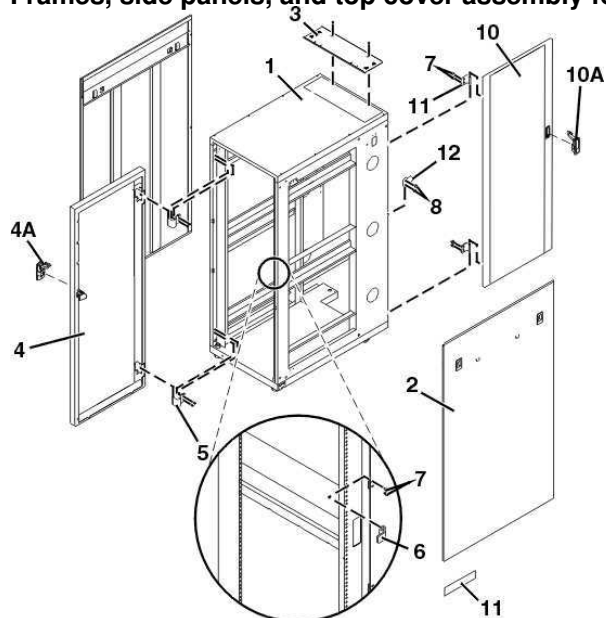


Table 1. Frames, side panels, and top cover assembly part numbers for 14T/00 and 14T/42

| Index Number | Part Number | Units            | Description                                               |
|--------------|-------------|------------------|-----------------------------------------------------------|
| 1            | 41V0486     | 1                | Frame (14T/00 black, 1.8 m)                               |
|              | 05N4867     | 1                | Frame (14T/00, white, 1.8 m)                              |
|              | 11P0313     | 1                | Frame (14T/42, black, 2.0 m)                              |
|              | 11P0314     | 1                | Frame (14T/42, white, 2.0 m)                              |
| 2            | 05N6478     | 2                | Side panel (14T/00 and 14T/42, black)                     |
|              | 05N6477     | 2                | Side panel (14T/00 and 14T/42, white)                     |
| 3            | 21L4290     | 1                | Top cover (14T/00 and 14T/42, white, 14T/42 cable access) |
|              | 21L4277     | 1                | Top cover (14T/00 and 14T/42, black, 14T/42 cable access) |
| 4            | 05N4863     | 1                | 14T/00, black (55 mm)                                     |
|              | 11P0319     | 1                | 14T/42, black (55 mm)                                     |
|              | 12K0456     | 1                | 14T/00, white (35 mm)                                     |
|              | 11P0318     | 1                | 14T/42, white (35 mm)                                     |
|              | 32P1029     | 1                | 14T/00, High Perforation front door for 1.8M racks, black |
|              | 45P1429     | 1                | 14T/42, High Perforation front door for 2M racks, black   |
|              | 21P4049     | 1                | 14T/00, (100 mm)                                          |
| 21P4729      | 1           | 14T/42, (100 mm) |                                                           |
| 5            | 11P4106     | 2                | Hinge (55 mm)                                             |
|              | 09N9686     | 2                | Hinge (High Perforation front Door)                       |



Service provider information

|     |         |    |                                         |
|-----|---------|----|-----------------------------------------|
|     | 05N4865 | 2  | Hinge (35 mm)                           |
|     | 21P4042 | 2  | Hinge (100 mm)                          |
| 6   | 41V0082 | 1  | Latch plate (55 mm)                     |
|     | 05N4866 | 1  | Latch plate (35 mm)                     |
|     | 21P4043 | 1  | Latch plate (100 mm)                    |
| 7   | 31L8594 | 4  | Screw                                   |
| 8   | 31L7540 | 2  | Screw                                   |
| 9   | 51H9502 | 11 | Hook-and-loop fastener                  |
| 10  | 11P0725 | 1  | 14T/00, with foam, round, white (20 mm) |
|     | 11P0723 | 1  | 14T/42, with foam, round, white (20 mm) |
|     | 21P4468 | 1  | 14T/00, with foam, hex, black (20 mm)   |
|     | 21P4467 | 1  | 14T/42, with foam, hex, black (20 mm)   |
| 10A | 21P4054 | 1  | Latch                                   |
| 11  | 31L7533 | 2  | Hinge (20 mm)                           |
| 12  | 31L7531 | 1  | Latch plate (20 mm)                     |

**Top frame assembly for 14T/42**

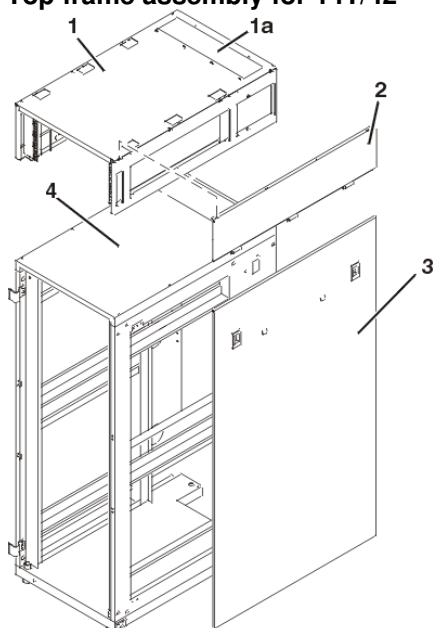


Table 2. Top frame assembly part numbers for 14T/42

| Index number                                                                                                                                                                                        | Part number | Units | Description                    |
|-----------------------------------------------------------------------------------------------------------------------------------------------------------------------------------------------------|-------------|-------|--------------------------------|
| 1                                                                                                                                                                                                   | **21L4296   | 1     | Top frame                      |
| ** This is the only orderable top frame part number. This part has a default color of white. If you need a black top frame, request it when you place the order along with the 21L4296 part number. |             |       |                                |
| 1a                                                                                                                                                                                                  | 21L4277     | 1     | Top Cable Access Cover (Black) |
| 1a                                                                                                                                                                                                  | 21L4290     | 1     | Top Cable Access Cover (White) |
| 2                                                                                                                                                                                                   | 31L7536     | 2     | Top Frame Side Panel (Black)   |
| 2                                                                                                                                                                                                   | 05N6805     | 2     | Top Frame Side Panel (White)   |

Service provider information

|   |         |   |                          |
|---|---------|---|--------------------------|
| 3 | 05N6478 | 2 | Lower Side Panel (Black) |
| 3 | 05N6477 | 2 | Lower Side Panel (White) |
| 4 | 11P0313 | 1 | Rack Frame (Black)       |
| 4 | 11P0314 | 1 | Rack Frame (White)       |

**Earthquake brace assembly for 14T/00 and 14T/42**

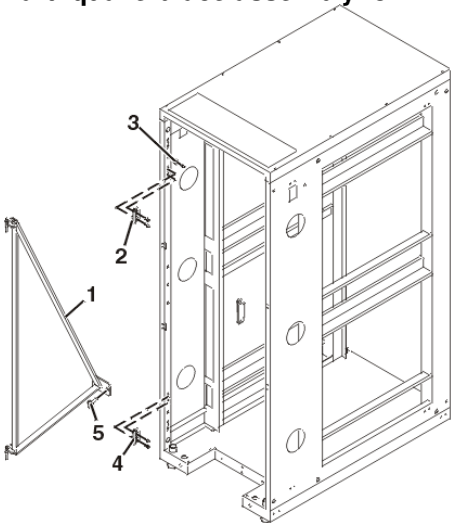


Table 3. Earthquake brace assembly part numbers for 14T/00 and 14T/42

| Index number | Part number | Units | Description          |
|--------------|-------------|-------|----------------------|
| 1            | 41V0488     | 1     | Earthquake brace kit |
| 2            | REF         | 2     | Hinge                |
| 3            | REF         | 1     | Spacer               |
| 4            | REF         | 7     | Screw                |
| 5            | 76X4687     | 1     | Bolt                 |

**Blank fillers assembly for 14T/00 and 14T/42**

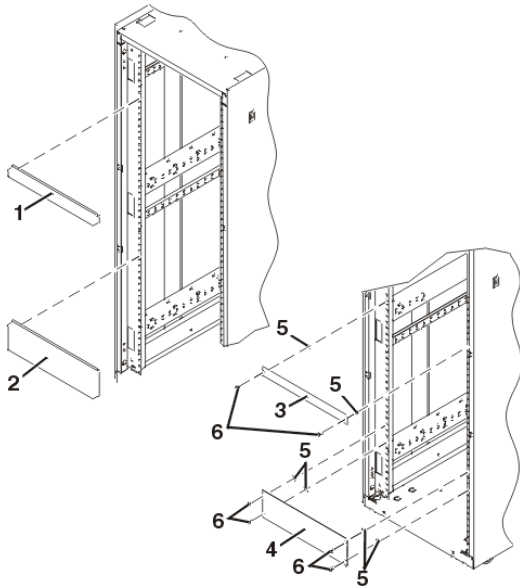


Table 4. Blank fillers assembly part numbers for 14T/00 and 14T/42

| Index number | Part number | Units | Description             |
|--------------|-------------|-------|-------------------------|
| 1            | 97H9754     | AR    | 1U Filler snap (black)  |
|              | 62X3443     | AR    | 1U Filler snap (white)  |
| 2            | 97H9755     | AR    | 3U Filler snap (black)  |
|              | 62X3444     | AR    | 3U Filler snap (white)  |
| 3            | 12J4072     | AR    | 1U Filler screw (black) |
| 4            | 12J4073     | AR    | 3U Filler screw (black) |
| 5            | 74F1823     | AR    | M5 Nut clip             |
|              | 74F1823     | AR    | M5 Nut clip             |
| 6            | 1624779     | AR    | M5 X 14 Hex flange      |
|              | 1624779     | AR    | M5 X 14 Hex flange      |

**Power distribution bus assembly for 14T/00 and 14T/42**

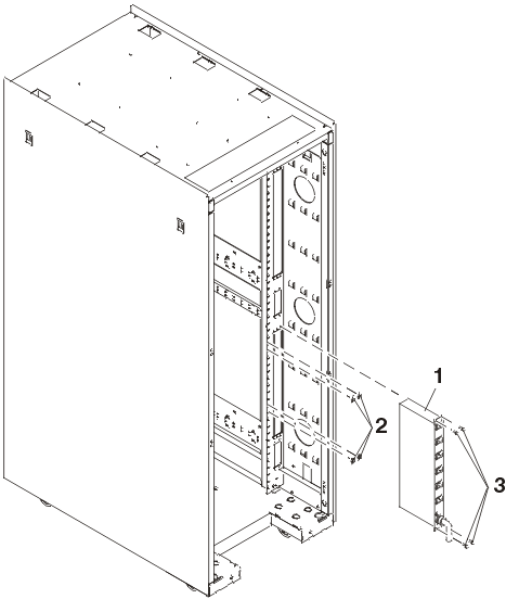


Table 5. Power distribution bus assembly part numbers for 14T/00 and 14T/42

| Index number | Part number | Units | Description                                                                                         |
|--------------|-------------|-------|-----------------------------------------------------------------------------------------------------|
| 1            | 00P2200     | 1     | Type 6 power distribution panel (1 phase U.S.)                                                      |
|              | 00P2201     | 1     | Type 6 power distribution panel (2/3 phase)                                                         |
|              | 00P2202     | 1     | Type 6 power distribution panel (3 phase)                                                           |
|              | 00P2203     | 1     | Type 6 power distribution panel (1 Phase World Trade)                                               |
|              | 00P3663     | 1     | Type 7 Power distribution panel (1 Phase)                                                           |
|              | 00P3665     | 1     | Type 7 Power distribution panel (1 Phase World Trade)                                               |
|              | 00P3667     | 1     | Type 7 Power distribution panel (3 Phase World Trade)                                               |
|              | 39J1183     | 1     | Power Distribution Unit (PDU) has twelve customer-usable IEC 320-C13 outlets rated at 200-240 V ac. |
| 2            | 1624779     | 4     | Nut Clip                                                                                            |
| 3            | 74F1823     | 4     | Screw                                                                                               |

**Note:** Type 6 power distribution buses have six IEC320-C13, 200 V to 240 V ac outlets. Type 7 power distribution buses have nine IEC320-C13, 200 V to 240 V ac outlets and two IEC320-C19, 200 V to 240 V ac outlets.

**Stabilizer assembly for 14T/00 and 14T/42**

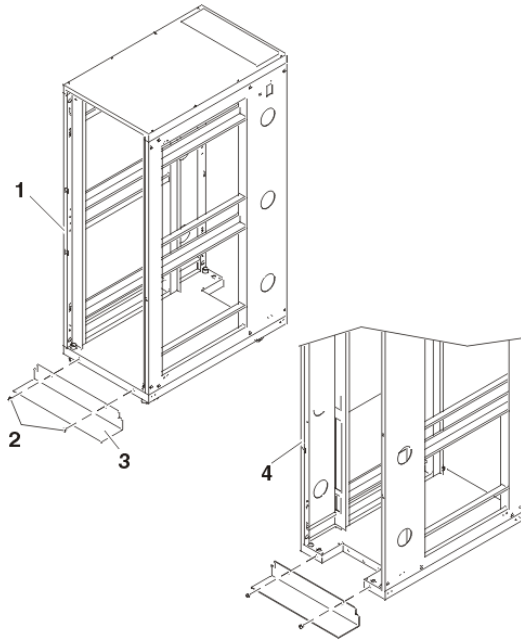


Table 6. Stabilizer assembly for 14T/00 and 14T/42

| Index number | Part number | Units | Description                                                   |
|--------------|-------------|-------|---------------------------------------------------------------|
| 1            | REF         | 1     | Rack frame                                                    |
| 2            | REF         | 2     | Screw, M8X25 button head (provided as part of stabilizer kit) |
| 3            | 31L8305     | 1     | Front stabilizer kit (black)                                  |
| 3            | 31L8306     | 1     | Front stabilizer kit (white)                                  |
| 3            | 44P1850     | 1     | Back stabilizer kit (black)                                   |
| 3            | 44P1851     | 1     | Back stabilizer kit (white)                                   |
| 4            | REF         | 1     | Rack frame                                                    |

**Power distribution panel assembly for 14T/00 and 14T/42**

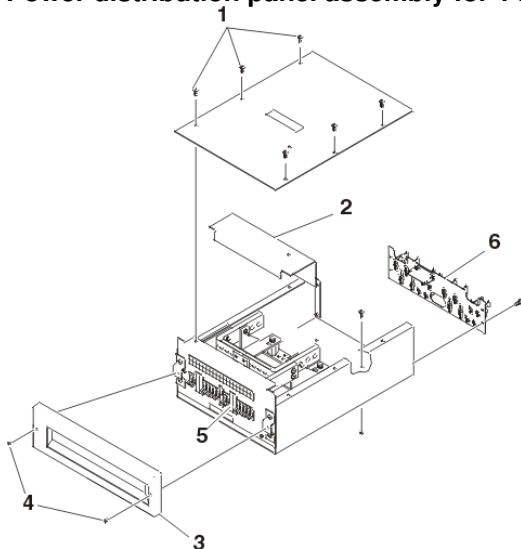


Table 7. Power distribution panel assembly part numbers for 14T/00 and 14T/42

| Index number | Part number | Units | Description                                      |
|--------------|-------------|-------|--------------------------------------------------|
| 1            | 1621191     | 6     | Screw, M4 x 10                                   |
| 2            | 88G4824     | 1     | Bus bar shield                                   |
| 3            | 93H4918     | 1     | Front bezel                                      |
| 4            | 93H4919     | 2     | Screws, 10-32 button head                        |
| 5            | REF         | AR    | Filler plate for empty circuit breaker positions |
|              | 93H7601     | AR    | 1 amp circuit breaker                            |
|              | 93H7600     | AR    | 5 amp circuit breaker                            |
|              | 08L0335     | AR    | 20 amp circuit breaker                           |
|              | 93H6391     | AR    | 30 amp circuit breaker                           |
|              | 8185537     | AR    | 50 amp circuit breaker                           |
| 6            | 8185540     | 1     | I/O backplane                                    |

**Power distribution panel interior assembly for 14T/00 and 14T/42**

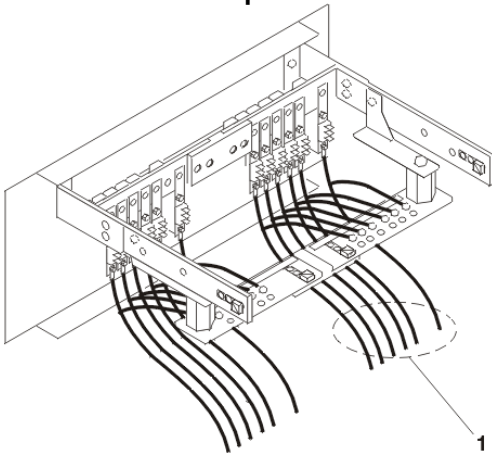


Table 8. Power distribution panel interior assembly part numbers for 14T/00 and 14T/42

| Index number | Part number | Units  | Description  |
|--------------|-------------|--------|--------------|
| 1            | 00P1793     | varies | 20 amp cable |
|              | 11K0402     | varies | 30 amp cable |
|              | 11K0401     | varies | 50 amp cable |

**Leveling feet assembly for 14T/00 and 14T/42**

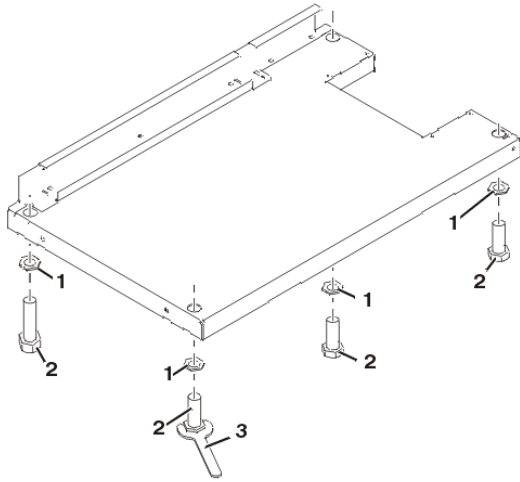


Table 9. Leveling feet assembly part numbers for 14T/00 and 14T/42

| Index number | Part number | Units | Description   |
|--------------|-------------|-------|---------------|
| 1            | REF         | 4     | Jam nut       |
| 2            | REF         | 4     | Leveling Feet |
| 3            | 31L8313     | 1     | Wrench        |

**Brace assembly for 14T/42**

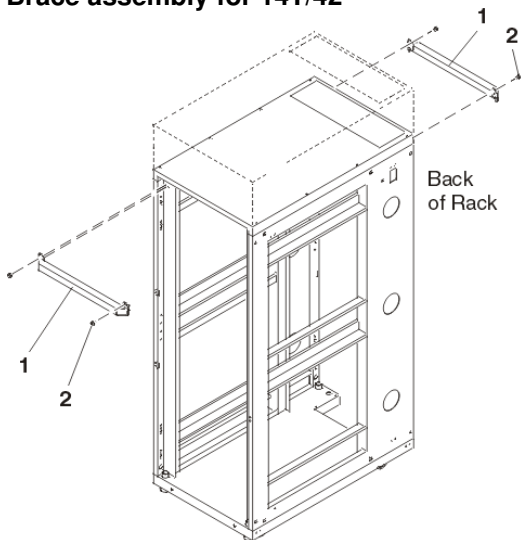


Table 10. Brace assembly part numbers for 14T/42

| Index number | Part number | Units | Description |
|--------------|-------------|-------|-------------|
| 1            | 12K0489     | 2     | Brace       |
| 2            | REF         | 4     | Bolt        |

**Heat exchanger rear door for 14T/42**

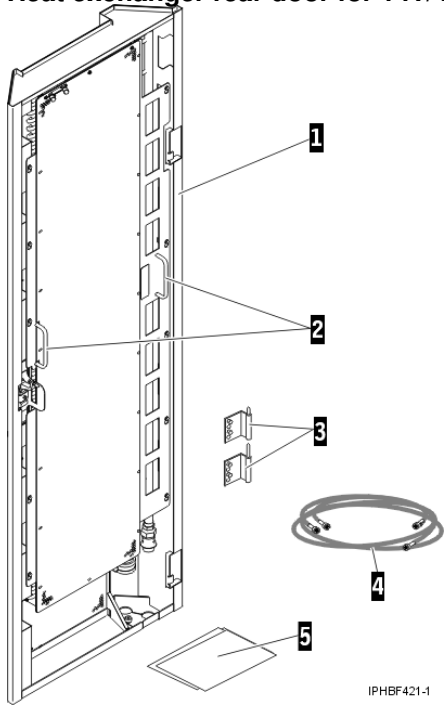


Table 11. Rear heat exchanger door for 14T/42

| Index number | Part number | Units | Description                                                         |
|--------------|-------------|-------|---------------------------------------------------------------------|
| 1            | 32R0712     | 1     | Heat exchanger rear door assembly (comes complete with parts shown) |
| 2            | N/A         |       | Handles                                                             |
| 3            | N/A         |       | Hinge kit                                                           |
| 4            | N/A         |       | Air-purging tool                                                    |
| 5            | N/A         |       | Documentation                                                       |

**Rack beacon assembly for 14T/00 and 14T/42**



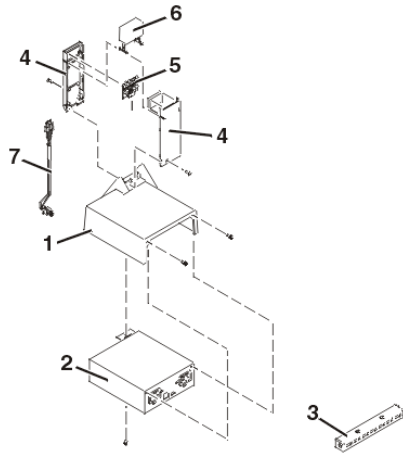


Table 12. Rack beacon assembly part numbers for 14T/00 and 14T/42

| Index number | Part number | Units | Description           |
|--------------|-------------|-------|-----------------------|
| 1            | 53P1775     | 1     | Cover                 |
| 2            | 53P1774     | 1     | Power supply          |
| 3            | 53P2231     | 1     | Junction box assembly |
| 4            | 53P1776     | 2     | Arm                   |
| 5            | 53P3997     | 1     | Card assembly         |
| 6            | 53P1777     | 1     | Lens                  |
| 7            | 53P2236     | 1     | Cable                 |
| Not Shown    | 53P2237     | AR    | USB cable             |
| Not Shown    | 53P2854     | 1     | USB cable             |

Parent topic: [Part assembly diagrams](#)

## Part assembly diagrams for 05/54 and 14S/11 racks

### Final assembly

Table 1. Final assembly part numbers

| Index number | Part number | Units per assembly | Description                                           |
|--------------|-------------|--------------------|-------------------------------------------------------|
|              | 32P1629     | 1                  | Rack door lock                                        |
|              | 32P1633     | 1                  | Tilt foot kit                                         |
|              | 12J3279     | 4                  | Fixed caster                                          |
|              | 12J3283     | 4                  | Swivel caster                                         |
|              | 00P2200     | 1                  | Type 6 power distribution panel (1 phase U.S.)        |
|              | 00P2201     | 1                  | Type 6 power distribution panel (2/3 phase)           |
|              | 00P2202     | 1                  | Type 6 power distribution panel (3 phase)             |
|              | 00P22023    | 1                  | Type 6 power distribution panel (1 Phase World Trade) |

Service provider information

|  |          |   |                                                                                                     |
|--|----------|---|-----------------------------------------------------------------------------------------------------|
|  | 00P3663  | 1 | Type 7 Power distribution panel (1 Phase)                                                           |
|  | 00P3665  | 1 | Type 7 Power distribution panel (1 Phase World Trade)                                               |
|  | 00P3667  | 1 | Type 7 Power distribution panel (3 Phase World Trade)                                               |
|  | 039J1183 | 1 | Power Distribution Unit (PDU) has twelve customer-usable IEC 320-C13 outlets rated at 200-240 V ac. |

**Note:** Type 6 power distribution buses have six IEC320-C13, 200 V to 240 V ac outlets. Type 7 power distribution buses have nine IEC320-C13, 200 V to 240 V ac outlets and two IEC320-C19, 200 V to 240 V ac outlets.

Parent topic: [Part assembly diagrams](#)

## Part assembly diagrams for 05/55 and 14S/25 racks

### Final assembly

Table 1. Final assembly part numbers

| Index number | Part number | Units per assembly | Description                                                                                         |
|--------------|-------------|--------------------|-----------------------------------------------------------------------------------------------------|
|              | 13N2060     | 1                  | Split door, right                                                                                   |
|              | 13N2061     | 1                  | Split door, left                                                                                    |
|              | 16R1491     | 1                  | Top cover                                                                                           |
|              | 16R1490     | 2                  | Side panel                                                                                          |
|              | 16R1496     | 1                  | Latch                                                                                               |
|              | 16R1497     | 1                  | Keys                                                                                                |
|              | 16R1489     | 1                  | Front door                                                                                          |
|              | 16R1499     | 1                  | Hardware kit                                                                                        |
|              | 16R1495     | 1                  | Front stabilizer                                                                                    |
|              | 16R1494     | 2                  | Adjustable foot                                                                                     |
|              | 16R1492     | 2                  | Fixed caster, front                                                                                 |
|              | 16R1493     | 2                  | Swivel caster, back                                                                                 |
|              | 39M6653     | AR                 | Kit, cable management                                                                               |
|              | 00P2200     | 1                  | Type 6 power distribution panel (1 phase U.S.)                                                      |
|              | 00P2201     | 1                  | Type 6 power distribution panel (2/3 phase)                                                         |
|              | 00P2202     | 1                  | Type 6 power distribution panel (3 phase)                                                           |
|              | 00P22023    | 1                  | Type 6 power distribution panel (1 Phase World Trade)                                               |
|              | 00P3663     | 1                  | Type 7 Power distribution panel (1 Phase)                                                           |
|              | 00P3665     | 1                  | Type 7 Power distribution panel (1 Phase World Trade)                                               |
|              | 00P3667     | 1                  | Type 7 Power distribution panel (3 Phase World Trade)                                               |
|              | 039J1183    | 1                  | Power Distribution Unit (PDU) has twelve customer-usable IEC 320-C13 outlets rated at 200-240 V ac. |

**Note:** Type 6 power distribution buses have six IEC320-C13, 200 V to 240 V ac outlets. Type 7 power distribution buses have nine IEC320-C13, 200 V to 240 V ac outlets and two IEC320-C19, 200 V to 240 V ac outlets.

**Parent topic:** [Part assembly diagrams](#)

---

## Cables

Use this parts listing to find internal power and signal cables and external cables.

See the following for other parts:

- For parts that have CCINs, servers Failing Function Code numbers, or o/p, see [System parts](#).
- For mechanical and connecting parts, see [Part assembly diagrams](#).
- For miscellaneous parts such as cable wraps or cleaning kits, see [Miscellaneous parts](#).
- For Hardware Management Console (HMC) parts, see [Hardware Management Console \(HMC\) parts](#).

Select the type of cable you are working with:

- [Power and signal cables](#)
- [External cables](#)

**Parent topic:** [Part number catalog](#)

---

## Hardware Management Console (HMC) parts

Use this information to find part numbers for HMC.

### Personal computer parts

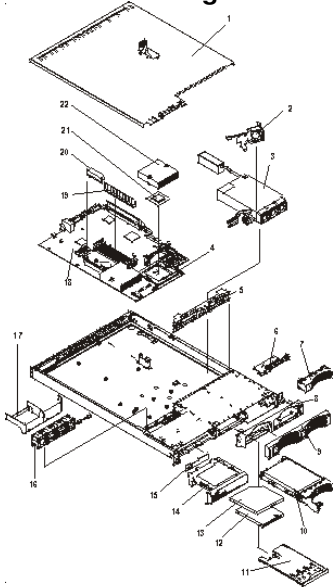
This information contains part number information for parts that are added to the base personal computer of the Hardware Management Console (HMC). These additional parts, when added to one of the following listed personal computers, make up your HMC.

The following table contains a cross-reference equivalent of the HMC machine type and model number to the personal computer machine type and model number.

| HMC machine type and model number<br>(available on the serial number plate of<br>your HMC) | Equivalent PC server<br>machine type and model<br>number | Order numbers for supporting<br>Hardware Maintenance Manuals<br>(HMM) |
|--------------------------------------------------------------------------------------------|----------------------------------------------------------|-----------------------------------------------------------------------|
| 10C/R2                                                                                     | 8676 Model 22X                                           | <a href="#">48P9908</a>                                               |
| 10C/R3                                                                                     | 8837 Model 22U                                           | <a href="#">25K8109</a>                                               |
| 10C/03                                                                                     | 8187 Model F4U (without<br>POV)                          | <a href="#">74P2661</a>                                               |
| 10C/04                                                                                     | 8141 Model 31U                                           | <a href="#">19R0486</a>                                               |
| 7310-C05                                                                                   | 8485 Model 2AU                                           | <a href="#">31R2005</a>                                               |

For the latest information regarding maintenance of your HMC PC, system board specifications, and parts, refer to the PC hardware maintenance manuals.

### Hardware Management Console model 10C/R2 parts



| Index | Description                          | Units | Part numbers |
|-------|--------------------------------------|-------|--------------|
| 1     | Top cover assembly                   | 1     | 24P0708      |
| 2     | Fan, DASD                            | 1     | 00N6991      |
| 3     | Power Supply (332W)                  |       | 49P2090      |
| 4     | Heat sink Retention Module           | 1     | 24P0836      |
| 5     | Hot-Swap SCSI Backplane              |       | 32P1932      |
| 6     | Operator Information Card            |       | 48P9086      |
| 7     | Bezel Filler                         |       | 06P6245      |
| 8     | Bezel, Hot Swap Trim                 |       | 24P0720      |
| 9     | Bezel, Non-Hot Swap Trim             |       | 24P0723      |
| 10    | 40GB IDE Drive (7200 RPM)            |       | 19K1568      |
| 11    | USB Tray                             |       | 32P0580      |
| 12    | 12.7, 3 MODE Diskette Drive          |       | 36L8645      |
| 13    | 24X CD-ROM drive (primary)           |       | 06P5263      |
| 13    | 24X CD-ROM drive                     |       | 33P3231      |
| 13    | DVD-RAM                              |       | 33P3307      |
| 14    | Bracket, CD-ROM Drive/Diskette Drive |       | 32P1925      |
| 15    | Interposer Card                      |       | 48P9028      |
| 16    | Microprocessor Fan                   |       | 24P1118      |
| 17    | Baffle                               |       | 24P0742      |

## Service provider information

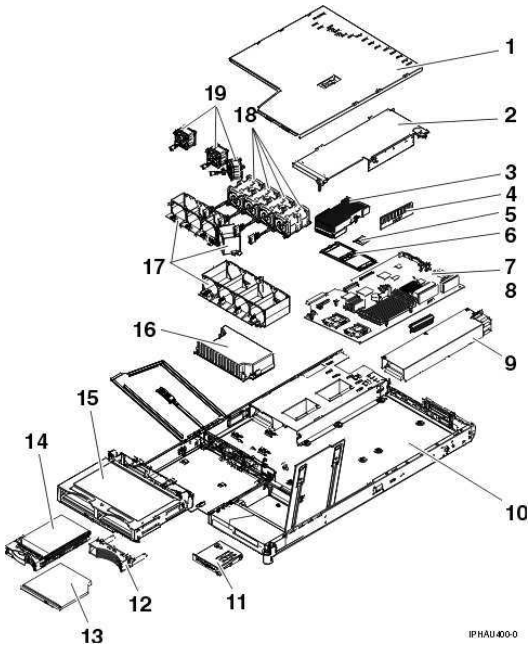
|     |                                  |  |                    |
|-----|----------------------------------|--|--------------------|
| 17a | Chassis                          |  | 32P1924            |
| 18  | System Board                     |  | 88P9728<br>25R3039 |
| 19  | 256 PC2100 ECC<br>Memory DIMM    |  | 09N4306            |
| 19  | 512 MB Memory DIMM               |  | 09N4307            |
| 19  | 1 GB Memory DIMM                 |  | 09N4308            |
| 20  | 9.0 1U/13A VRM Card,             |  | 74P4407            |
| 21  | 533/3.06-0K L3<br>Microprocessor |  | 02R8908            |
| 22  | 533 Heat sink                    |  | 24P0891            |

The following table contains part descriptions and part numbers for parts not shown in the 10C/R2 illustration.

| Description                                                                                                                                                                                                                                                                                                                                                                                                                                                                  | Units | Part Numbers |
|------------------------------------------------------------------------------------------------------------------------------------------------------------------------------------------------------------------------------------------------------------------------------------------------------------------------------------------------------------------------------------------------------------------------------------------------------------------------------|-------|--------------|
| 3.0 V battery                                                                                                                                                                                                                                                                                                                                                                                                                                                                |       | 33F8354      |
| Mouse                                                                                                                                                                                                                                                                                                                                                                                                                                                                        |       | 24P0507      |
| Mouse Cable                                                                                                                                                                                                                                                                                                                                                                                                                                                                  |       | 00N6954      |
| C2T Cable (FC 4271) 0.26 m, HMC to HMC,<br>(Keyboard/Video/Mouse)                                                                                                                                                                                                                                                                                                                                                                                                            |       | 00N7003      |
| C2T Cable (FC 4272) 2 m, HMC to HMC,<br>(Keyboard/Video/Mouse)                                                                                                                                                                                                                                                                                                                                                                                                               |       | 00N7006      |
| -48V Connector                                                                                                                                                                                                                                                                                                                                                                                                                                                               |       | 01R1199      |
| 40x20 Fan Assembly Duct                                                                                                                                                                                                                                                                                                                                                                                                                                                      |       | 24P0892      |
| 1U Tool-less Rail Kit                                                                                                                                                                                                                                                                                                                                                                                                                                                        |       | 24P1121      |
| PC-Doctor Diagnostic Diskette                                                                                                                                                                                                                                                                                                                                                                                                                                                |       | 21H4251      |
| Service Label                                                                                                                                                                                                                                                                                                                                                                                                                                                                |       | 33P2339      |
| Non-Hot Swap Hard Disk Drive Rail Kit                                                                                                                                                                                                                                                                                                                                                                                                                                        |       | 32P1928      |
| 3.5V Riser Assembly                                                                                                                                                                                                                                                                                                                                                                                                                                                          |       | 25P3359      |
| Jumper Cord                                                                                                                                                                                                                                                                                                                                                                                                                                                                  |       | 36L8886      |
| CD-ROM Drive Power Cable                                                                                                                                                                                                                                                                                                                                                                                                                                                     |       | 24P0867      |
| CD-ROM Signal Cable                                                                                                                                                                                                                                                                                                                                                                                                                                                          |       | 24P0851      |
| Hard Disk Drive Power Fixed 2-Drop Cable                                                                                                                                                                                                                                                                                                                                                                                                                                     |       | 24P0865      |
| Cable, switch and USB                                                                                                                                                                                                                                                                                                                                                                                                                                                        |       | 24P0853      |
| Cable, diskette drive signal                                                                                                                                                                                                                                                                                                                                                                                                                                                 |       | 24P0790      |
| Cable, IDE drive                                                                                                                                                                                                                                                                                                                                                                                                                                                             |       | 24P0788      |
| Hot-Swap SCSI Assembly Cable                                                                                                                                                                                                                                                                                                                                                                                                                                                 |       | 24P0786      |
| Cable, hard disk drive 4-pin power                                                                                                                                                                                                                                                                                                                                                                                                                                           |       | 24P0622      |
| Hard Disk Drive Backplane to System Board Cable                                                                                                                                                                                                                                                                                                                                                                                                                              |       | 00N6988      |
| Power cord                                                                                                                                                                                                                                                                                                                                                                                                                                                                   |       | 6952300      |
| Miscellaneous parts kit - contains:<br><br><ul style="list-style-type: none"> <li>• CD-ROM drive spring rod (1)</li> <li>• Diskette drive spring rod (1)</li> <li>• Screws (10)</li> <li>• PCI card support bracket (1)</li> <li>• Icon light pipe (1)</li> <li>• Rear light pipe (1)</li> <li>• CD-ROM drive blank bezel (1)</li> <li>• Diskette drive blank bezel (1)</li> <li>• Slotted M3x5 screws (18)</li> <li>• I/O bracket (2)</li> <li>• Fan bracket (1)</li> </ul> |       | 32P1926      |

- 40 mm by 20 mm fan bracket (1) (all models) FRU

## 10C/R3 Hardware Management Console parts



### Notes:

1. Field replaceable units (FRUs) must be serviced only by an authorized service provider.
2. Customer replaceable units (CRUs) can be replaced by the customer. A definition of Tier 1 and Tier 2 CRUs for this model HMC is:
  - Tier 1 CRU
 

Procedure that a customer can perform without input from a service representative. The procedure used to service this type of component is usually required to be done by the customer.
  - Tier 2 CRU
 

Procedure that a customer can perform, but may require support from a service representative. The procedure used to service this component is usually not required to be done by the customer.
3. If the part you are replacing is not identified as being either Tier 1 or Tier 2 call your service representative to service the FRU.

Table 1. 10C/R3 Parts listing

| Index | Description                                      | Tier 1 CRUs | Tier 2 CRUs | Part Number |
|-------|--------------------------------------------------|-------------|-------------|-------------|
| 1     | Top cover                                        | *           |             | 23K4219     |
| 2     | Riser card assembly, PCI                         |             | *           | 23K4211     |
|       | Riser card (PCI-X)                               | *           |             | 90P1957     |
| 3     | Heat sink (field replaceable unit)               |             |             | 90P5281     |
| 4     | Memory, 512MB ECC DRR                            | *           |             | 13N1424     |
| 5     | Microprocessor, 3.4 GHz (field replaceable unit) |             |             | 13M8295     |

## Service provider information

|    |                                                                                                                                                |   |   |         |
|----|------------------------------------------------------------------------------------------------------------------------------------------------|---|---|---------|
|    | <b>Note:</b> Use BIOS CD FRU P/N 03N5955 when replacing the microprocessor if the HMC BIOS level of 1.06 or later is not installed in the CR3. |   |   |         |
| 6  | Heat sink retention module (field replaceable unit)                                                                                            |   |   | 90P5282 |
| 7  | System board (field replaceable unit)                                                                                                          |   |   | 39Y6958 |
|    | <b>Note:</b> When ordering or replacing a CR3 system board, you must order the HMC BIOS Update CD. The FRU part number is 03N5955.             |   |   |         |
| 8  | VRM, 1U/75A (on system board)                                                                                                                  | * |   | 39Y7261 |
| 9  | 585 W Power Supply                                                                                                                             | * |   | 39Y7169 |
|    | Power supply fan cable (field replaceable unit) (not shown)                                                                                    | * |   | 40K8160 |
| 10 | Chassis (field replaceable unit)                                                                                                               |   |   | 90P5284 |
| 11 | Control panel signal cable (field replaceable unit)                                                                                            |   |   | 25R4052 |
|    | Control panel (field replaceable unit) (not shown)                                                                                             |   |   | 39Y6912 |
| 12 | Bezel filler panel, hard disk drive                                                                                                            | * |   | 59P5236 |
| 13 | DVD-RAM Drive                                                                                                                                  |   | * | 39M3523 |
| 13 | DVD R/W Media                                                                                                                                  |   | * | 18P7250 |
| 14 | HDD 80 GB SATA                                                                                                                                 |   | * | 40K6867 |
|    | Cartridge SATA (not shown)                                                                                                                     |   | * | 40K8151 |
| 15 | Cage assembly, 3.5 in. SCSI hard disk drive, with CD and hard disk drive backplanes                                                            |   | * | 73P8007 |
| 16 | Power backplane                                                                                                                                |   | * | 40K8157 |
| 17 | Fan holder with fan backplanes                                                                                                                 |   | * | 40K8156 |
| 18 | Fan, 40x40x56                                                                                                                                  | * |   | 40K8140 |
| 19 | Fan, 40x40x28                                                                                                                                  | * |   | 40K8139 |
|    | 3.0 V battery                                                                                                                                  | * |   | 33F8354 |
|    | Bezel filler panel, SATA drive                                                                                                                 | * |   | 23K4990 |
|    | Bezel filler panel, DVD drive                                                                                                                  | * |   | 26K4300 |

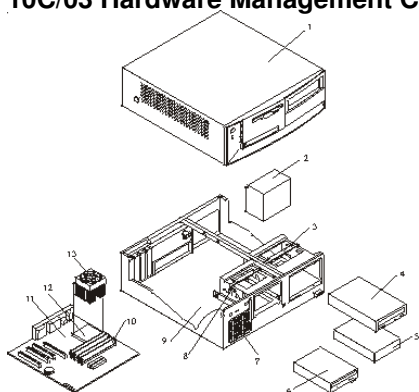
Table 2. 10C/R3 Parts listing

| Index | Description                                                                                                                                                                                                   | Units |   | Part Number |
|-------|---------------------------------------------------------------------------------------------------------------------------------------------------------------------------------------------------------------|-------|---|-------------|
|       | Cable assembly, 2.5 inch SCSI with power cable, signal cable, and bracket                                                                                                                                     |       | * | 23K4206     |
|       | Cable, 3.5 inch SCSI power                                                                                                                                                                                    |       | * | 23K4204     |
|       | Cable management arm                                                                                                                                                                                          | *     |   | 90P1958     |
|       | Cable, signal, SCSI                                                                                                                                                                                           |       | * | 33P2353     |
|       | Filler panel                                                                                                                                                                                                  | *     |   | 26K8680     |
|       | Kit, miscellaneous parts (all models)                                                                                                                                                                         |       | * | 90P5285     |
|       | <ul style="list-style-type: none"> <li>• Bezel blank filler</li> <li>• EIA bracket assembly, left</li> <li>• EIA bracket assembly, right</li> <li>• Rail set, DVD</li> <li>• Power supply filler I</li> </ul> |       |   |             |

Service provider information

|  |                                                                                                                                                       |   |   |         |
|--|-------------------------------------------------------------------------------------------------------------------------------------------------------|---|---|---------|
|  | <ul style="list-style-type: none"> <li>• Screw, 3.5mm</li> <li>• Screw, M3.5 steel</li> </ul>                                                         |   |   |         |
|  | Kit, tool-less rail                                                                                                                                   | * |   | 23K4218 |
|  | Line cord                                                                                                                                             | * |   | 39M5247 |
|  | Power cord                                                                                                                                            | * |   | 39M5377 |
|  | Riser card, PCI-X 1.0                                                                                                                                 | * |   | 90P1957 |
|  | Service label                                                                                                                                         | * |   | 23K4220 |
|  | Service label, generic                                                                                                                                | * |   | 23K4991 |
|  | USB connector cable, front panel (field replaceable unit)                                                                                             |   |   | 40K8159 |
|  | Y cord, 1345mm                                                                                                                                        |   | * | 25R2567 |
|  | PC-Doctor Diagnostic Diskette                                                                                                                         | * |   | 21H4251 |
|  | HMC BIOS Update CD                                                                                                                                    |   |   | 03N5955 |
|  | <p><b>Note:</b> Use BIOS CD FRU P/N 03N5955 when replacing the microprocessor if the HMC BIOS level of 1.06 or later is not installed in the CR3.</p> |   |   |         |
|  | Mouse, (Black)                                                                                                                                        | * |   | 03N6669 |

10C/03 Hardware Management Console parts



| Index | Description                         | Units | Part Numbers       |
|-------|-------------------------------------|-------|--------------------|
| 1     | Top cover assembly                  | 1     | 88P5962            |
| 2     | Power supply, 230W                  | 1     | 74P4300<br>74P4301 |
| 3     | DVD-RAM                             |       | 33P3309            |
|       | DVD-RW drive                        |       | 26K5383            |
|       | CD-ROM drive                        |       | 33P3243            |
| 4     | HDD, 40 GB EIDE                     | 1     | 19K1568            |
| 5     | FDD, 3.5 1.44 MB                    |       | 76H4091            |
| 6     | Chassis/top cover kit               |       | 88P5963            |
| 7     | System board, Gigabit Ethernet, POV |       | 89P7944            |
| 8     | Intel P4 3.0 GHz                    |       | 88P5870            |
|       | Fan sink                            |       | 01R3330<br>32P4004 |



The following table contains part descriptions and part numbers for parts not shown in the 10C/03 illustration.

| Description                         | Units | Part Numbers |
|-------------------------------------|-------|--------------|
| 256 MB SDRAM                        |       | 31P9121      |
| 512 MB SDRAM                        |       | 31P9122      |
| RFID antenna - hook-and-loop fasner |       | 03K9654      |
| 3.0 V battery                       |       | 33F8354      |
| Speaker with cable                  |       | 00N5151      |
| COM Port to Modem Async Cable       |       | 21L4322      |
| Cable, C2 assembly                  |       | 09K9827      |
| PC-Doctor Diagnostic Diskette       |       | 21H4251      |
| 5.25 EMC shield                     |       | 19K5548      |
| Retention kit                       |       | 88P5915      |
| Planar shield kit                   |       | 88P5931      |
| Cable, FDD                          |       | 88P6515      |
| Cable, HDD                          |       | 88P5928      |
| Cable, ATA66 1 drop                 |       | 88P5967      |
| Cable, ATA66 2 drop                 |       | 88P5971      |
| Cable, SATA                         |       | 88P5927      |
| HMC Model CR3 BIOS Update CD        |       | 03N4720      |
| Service label                       |       | 88P5964      |
| Bezel kit                           |       | 49P4371      |
| Pivot lock, 3.5 FDD                 |       | 09N5748      |
| Pivot lock, 5.25 DASD               |       | 09N5747      |
| Fan bracket assembly                |       | 88P6700      |
| Miscellaneous hardware kit          |       | 88P5965      |
| Cable, CD-ROM audio                 |       | 75H9219      |
| Mouse                               |       | 24P0507      |
| Keylock assembly, random            |       | 88P5920      |
| HDD mounting bracket assembly       |       | 88P5916      |
| Cable assembly, power/LED           |       | 37L5092      |
| Cable, second system port           |       | 49P4530      |
| Cable, dual USB 2.0                 |       | 49P4365      |
| ASYNC 8 Way Adapter                 |       | 93H6541      |
| ASYNC 128 Way Adapter               |       | 93H6545      |
| 10/100 Ethernet Adapter             |       | 09P5023      |

#### 10C/04 Hardware Management Console parts

##### Notes:

1. Field replaceable units (FRUs) must be serviced only by an authorized service provider.
2. Customer replaceable units (CRUs) can be replaced by the customer. Tier 1 and Tier 2 CRUs for this model HMC are defined as follows:  
Tier 1 CRU

Procedure that a customer can perform without input from a service representative. The procedure used to service this type of component is usually required to be done by the customer.

Tier 2 CRU

Procedure that a customer can perform, but may require support from a service representative. The procedure used to service this component is usually not required to be done by the customer.

- If the part you are replacing is not identified as being either Tier 1 or Tier 2, call your service representative to service the FRU.

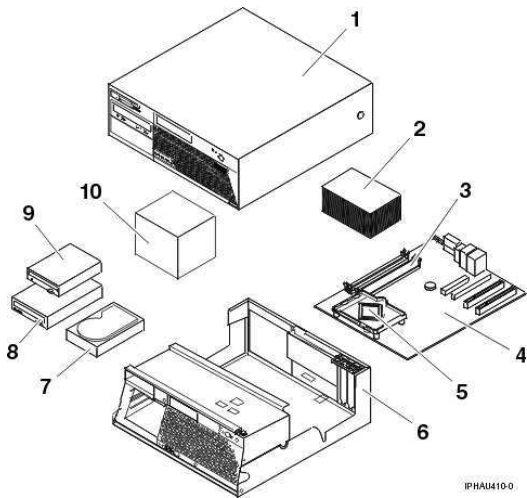


Table 3. 10C/04 Parts listing

| Index | Description                                              | Tier 1 CRU | Tier 2 CRU | Part Number |
|-------|----------------------------------------------------------|------------|------------|-------------|
| 1     | Top Cover assembly                                       | *          |            | 89P6730     |
| 2     | Heat sink                                                |            | *          | 89P6729     |
| 3     | 256MB PC2 3200 Memory DDR1                               | *          |            | 73P2683     |
| 3     | 512MB PC2 3200 Memory DDR1                               | *          |            | 73P2684     |
| 4     | System board 10/1000 w/ POV                              |            | *          | 29R8260     |
| 5     | 3.2 GHZ Prescott P4                                      |            | *          | 19R0497     |
| 6     | Chassis and top cover kit                                |            | *          | 89P6732     |
| 7     | HDD 80GB SATA                                            | *          |            | 73P8000     |
| 8     | DVD                                                      | *          |            | 09P5407     |
| 8     | DVD (Black)                                              | *          |            | 33P3309     |
| 9     | 3.5 - 1.44MB 2 MODE FDD wo/Bezel                         | *          |            | 76H4091     |
| 9     | 3.5 - 1.44MB 2MODE FDD (wo/Bezel) -- optional to 76H4091 | *          |            | 33P3343     |
| 10    | Power Supply 310 Watt                                    |            | *          | 24R2574     |

10C/04 FRU's listed in the following table are not illustrated

Table 4. 10C/04 Parts listing

| Description                                     | Tier 1 CRU | Tier 2 CRU | Part Number |
|-------------------------------------------------|------------|------------|-------------|
| HDD Mounting bracket assembly                   | *          |            | 88P5916     |
| Speaker assembly, internal (All EXCEPT CAU CBU) | *          |            | 00N5151     |
| Cable, Second System Port                       |            | *          | 49P4530     |

Service provider information

|                                             |   |   |                    |
|---------------------------------------------|---|---|--------------------|
| Retention module assembly                   | * |   | 89P6725            |
| Device Retaining Clips                      | * |   | 13N2449            |
| PC-Doctor Diagnostic Diskette               | * |   | 21H4251            |
| Fan and Duct assembly                       | * |   | 89P6726<br>39K5014 |
| System board shield                         | * |   | 89P6727            |
| Cable, SATA (all models)                    |   | * | 89P6728            |
| Bezel Kit (all models)                      | * |   | 89P6731            |
| Cable and Front USB/Audio Card (all models) | * |   | 89P6733            |
| Cable, 2-drop IDE                           |   | * | 89P6734            |
| Cable, FDD                                  |   | * | 89P6735            |
| Shield, Blank FDD                           | * |   | 89P6736            |
| Miscellaneous Hardware kit                  | * |   | 89P6737            |
| Cable, 1394 Front                           |   | * | 89P6738            |
| Cable, Power/LED                            |   | * | 89P6739            |
| 3.0 V battery                               | * |   | 33F8354            |
| Mouse, Optical Wheelmouse, USB 400 DPI      | * |   | 89P5089            |

### 7310-C05 Hardware Management Console parts

**Notes:**

1. Field replaceable units (FRUs) must be serviced only by an authorized service provider.
2. Customer replaceable units (CRUs) can be replaced by the customer. A definition of Tier 1 and Tier 2 CRUs for this model HMC is:
  - Tier 1 CRU
    - Uses a procedure that a customer can perform without input from a service representative.
    - The procedure used to service this type of component is usually required to be done by the customer.
  - Tier 2 CRU
    - Uses a procedure that a customer can perform, but may require support from a service representative. The procedure used to service this component is usually not required to be done by the customer.
3. If the part you are replacing is not identified as being either Tier 1 or Tier 2 call your service representative to service the FRU.

Service provider information

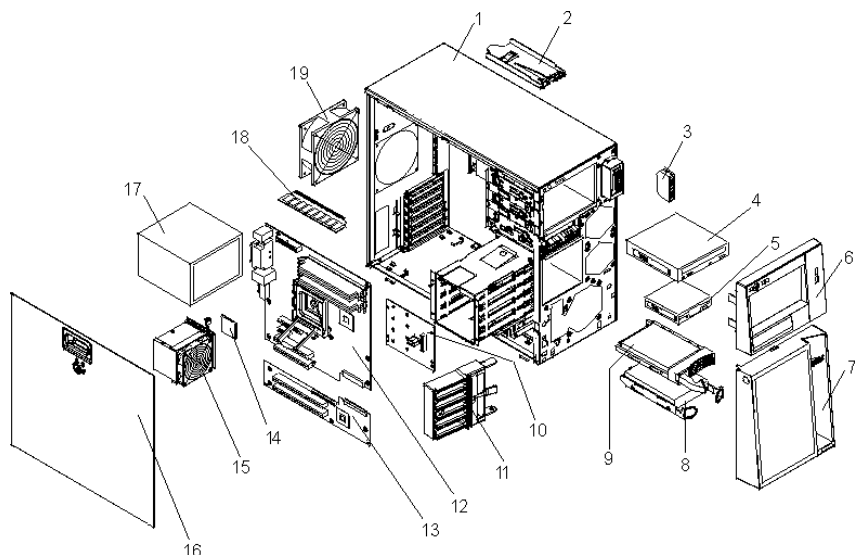


Table 5. 7310-C05 (8485-2AU) Parts listing

| Index | Description                                               | Tier 1 CRU | Tier 2 CRU | Part Number |
|-------|-----------------------------------------------------------|------------|------------|-------------|
| 1     | Chassis assembly, non-redundant power supply              |            |            | 25R8834     |
| 2     | Front-panel assembly                                      |            | *          | 25R8866     |
| 3     | Front USB port cable connector                            |            | *          | 11X0082     |
| 4     | DVD-RAM drive, 6 HLDS                                     | *          |            | 39M3519     |
| 5     | Diskette drive                                            | *          |            | 33P3343     |
| 6     | Bezel, upper                                              | *          |            | 25R8835     |
| 7     | Bezel, lower                                              | *          |            | 25R8822     |
| 8     | Hard disk drive, SATA, 80 GB, fixed/simple-swap with tray | *          |            | 39M4503     |
| 9     | Hard disk drive                                           | *          |            |             |
| 10    | SAS backplane                                             |            | *          | 11X0007     |
| 11    | Front adapter-retention bracket                           |            |            | 13N2993     |
| 12    | System board assembly                                     |            |            | 39M4477     |
| 13    | Expansion card                                            |            |            | 39M4478     |
| 14    | Microprocessor, 800/3.2 GHz - 2 MB                        |            |            | 39M4473     |
| 15    | Heat sink                                                 |            |            | 39R9308     |
| 16    | Cover, side                                               | *          |            | 25R8836     |
| 17    | Power supply, 400 watt                                    |            |            | 24R2666     |
| 18    | Memory, 512MB 533/667 Hz PC2-4200 ECC                     | *          |            | 30R5151     |
| 19    | System fan, rear                                          |            | *          | 25R8829     |

7310-C05 parts listed in the following table are not illustrated

Table 6. 7310-C05 Parts listing

| Index | Description            | Tier 1 CRU | Tier 2 CRU | Part Number |
|-------|------------------------|------------|------------|-------------|
|       | Backplate, simple-swap |            | *          | 25R8842     |
|       | 3.0 V battery          |            | *          | 33F8354     |
|       | Bezel kit              | *          |            | 13N2450     |
|       | Bezel, diskette drive  | *          |            | 25R8857     |

## Service provider information

|  |                            |   |   |         |
|--|----------------------------|---|---|---------|
|  | Cable, diskette drive      |   | * | 39R8112 |
|  | Cable, IDE signal          |   | * | 13N2466 |
|  | Cable, panel mount         |   | * | 13N2413 |
|  | EMC I/O shield             | * |   | 25R8843 |
|  | Keyboard, US               | * |   | 09P3247 |
|  | Mouse, USB                 | * |   | 09P3033 |
|  | Panel, access              | * |   | 25R8859 |
|  | Retainer, device           | * |   | 39R9369 |
|  | Retention module, fan sink |   |   | 25R8873 |
|  | System fan, front          |   | * | 25R8829 |
|  | TX 2-Port Ethernet adapter | * |   | 80P6450 |
|  | SATA RAID card             | * |   | 11X0033 |
|  | Display 19-inch TFT, black | * |   | 73P3890 |
|  | CD-ROM cable               | * |   | 11X0081 |
|  | CD-ROM Interposer card     | * |   | 11X0006 |
|  | Fan sink                   | * |   | 11X0043 |
|  | Tower mechanical parts     | * |   | 97P5754 |

### HMC Keyboard CRUs

The keyboards identified in the following table can be attached to any of the HMCs listed in the ESCALA Power5 Hardware Information.

#### Notes:

1. All keyboards are considered a Tier 1 CRU.
2. You will need the specific character set designed for each language installed on your HMC.

| Keyboard country code | FRU/CRU part number |
|-----------------------|---------------------|
| US English            | 10N6956             |
| Arabic                | 10N6984             |
| Belgian/French        | 89P8302             |
| Belgian/UK            | 10N6969             |
| Bulgarian             | 10N6972             |
| Brazilian Portuguese  | 10N6963             |
| Chinese/US            | 10N6966             |
| Czech                 | 10N6981             |
| Danish                | 10N6971             |
| Dutch                 | 10N6975             |
| English/EMEA          | 10N6988             |
| French                | 10N6957             |
| French Canadian 445   | 10N6967             |
| French Canadian 58    | 10N6968             |
| German                | 10N6959             |

## Service provider information

|                     |         |
|---------------------|---------|
| Greek               | 10N6977 |
| Hebrew              | 10N6978 |
| Hungarian           | 10N6964 |
| Icelandic           | 89P8317 |
| Italian 141         | 89P8318 |
| Italian 142         | 10N6958 |
| Japanese 194        | 10N6962 |
| Korean              | 10N6965 |
| LA Spanish          | 10N6983 |
| Norwegian           | 10N6974 |
| Polish              | 10N6979 |
| Portuguese          | 10N6976 |
| Romanian            | 89P8326 |
| Russian             | 10N6986 |
| Russian/Cyrillic    | 89P8328 |
| Serbian/Cyrillic    | 89P8329 |
| Slovak              | 10N6980 |
| Spanish             | 10N6961 |
| Swedish/Finnish     | 10N6870 |
| Swiss/French/Germay | 10N6973 |
| Thailand            | 89P8334 |
| Turkish 440         | 10N6982 |
| Turkish 179         | 89P8336 |
| UK English          | 10N6960 |
| US                  | 89P8338 |
| Yugoslav/Latin      | 89P8339 |

**HMC modem cable part numbers**

The following tables contain part number information for HMC modem cables, along with the name of the country where used, and a listing of countries along with the telephone cable name and part number where used.

| <b>Primary Country or Region</b> | <b>Cable Name</b> | <b>Cable Part Number</b> |
|----------------------------------|-------------------|--------------------------|
| Austria                          | AUS               | 21H4902                  |
| Australia                        | AUZ               | 75G3807                  |
| Belgium                          | BEL               | 21H4903                  |
| Denmark                          | DN                | 75G3812                  |
| Finland                          | FN                | 75G3809                  |
| France                           | FR                | 75G3803                  |
| Germany                          | GE                | 75G3804                  |
| Hong Kong (S.A.R.)               | HK                | 75G3808                  |
| Israel                           | ISR               | 21H4905                  |
| Italy                            | IT                | 75G3802                  |
| Netherlands                      | NL                | 75G3810                  |

#### Service provider information

|                |     |         |
|----------------|-----|---------|
| South Africa   | SAF | 21H4904 |
| Sweden         | SW  | 75G3806 |
| Switzerland    | SZ  | 75G3811 |
| United Kingdom | UK  | 75G3805 |
| United States  | US  | 87G6236 |

#### External Modems - Multitech II MT5600BA

The following table lists the external modem part number along with the primary country or region where used.

| Primary Country or Region | Modem Part Number |
|---------------------------|-------------------|
| United States             | 03N7035           |
| Australia                 | 03N7036           |
| Europe                    | 03N7037           |
| United Kingdom            | 03N7038           |
| China                     | 03N7039           |
| Taiwan                    | 03N7040           |
| All geographies           | 03N7041           |

#### Internal Modem

When ordering a replacement internal modem for your HMC use part number 80P4702.

#### Power cords

The manufacturer provides a power cord with a grounded attachment plug to use with this product. To avoid electrical shock, always use the power cord and plug with a properly grounded outlet.

Power cords used in the United States and Canada are listed by Underwriter's Laboratories (UL) and certified by the Canadian Standards Association (CSA).

For units intended to be operated at 115 volts: Use a UL-listed and CSA-certified cord set consisting of a minimum 18 AWG, Type SVT or SJT, three-conductor cord, a maximum of 15 feet in length and a parallel blade, grounding-type attachment plug rated 15 amperes, 125 volts.

For units intended to be operated at 230 volts (U.S. use): Use a UL-listed and CSA-certified cord set consisting of a minimum 18 AWG, Type SVT or SJT, three-conductor cord, a maximum of 15 feet in length and a tandem blade, grounding-type attachment plug rated 15 amperes, 250 volts.

For units intended to be operated at 230 volts (outside the U.S.): Use a cord set with a grounding-type attachment plug. The cord set should have the appropriate safety approvals for the country in which the equipment will be installed.

The power cords listed in the following table are specifically designed for a country or region and are usually available only in that country or region.

**Note:** All power cords are considered a Tier 1 CRU.

| Power Cord Part Number | Used in these Countries and Regions                                                                                                                                                                                                                                                                                                                                                                                                                                                                                                                                                                             |
|------------------------|-----------------------------------------------------------------------------------------------------------------------------------------------------------------------------------------------------------------------------------------------------------------------------------------------------------------------------------------------------------------------------------------------------------------------------------------------------------------------------------------------------------------------------------------------------------------------------------------------------------------|
| 13F9940                | Argentina, Australia, China (PRC), New Zealand, Papua New Guinea, Paraguay, Uruguay, Western Samoa                                                                                                                                                                                                                                                                                                                                                                                                                                                                                                              |
| 13F9979                | Afghanistan, Algeria, Andorra, Angola, Austria, Belgium, Benin, Bulgaria, Burkina Faso, Burundi, Cameroon, Central African Rep., Chad, China (Macau S.A.R.), Czech Republic, Egypt, Finland, France, French Guiana, Germany, Greece, Guinea, Hungary, Iceland, Indonesia, Iran, Ivory Coast, Jordan, Lebanon, Luxembourg, Malagasy, Mali, Martinique, Mauritania, Mauritius, Monaco, Morocco, Mozambique, Netherlands, New Caledonia, Niger, Norway, Poland, Portugal, Romania, Senegal, Slovakia, Spain, Sudan, Sweden, Syria, Togo, Tunisia, Turkey, former USSR, Vietnam, former Yugoslavia, Zaire, Zimbabwe |
| 13F9997                | Denmark                                                                                                                                                                                                                                                                                                                                                                                                                                                                                                                                                                                                         |
| 14F0015                | Bangladesh, Burma, Pakistan, South Africa, Sri Lanka                                                                                                                                                                                                                                                                                                                                                                                                                                                                                                                                                            |
| 14F0033                | Antigua, Bahrain, Brunei, Channel Islands, China (Hong Kong S.A.R.), Cyprus, Dubai, Fiji, Ghana, India, Iraq, Ireland, Kenya, Kuwait, Malawi, Malaysia, Malta, Nepal, Nigeria, Polynesia, Qatar, Sierra Leone, Singapore, Tanzania, Uganda, United Kingdom, Yemen, Zambia                                                                                                                                                                                                                                                                                                                                       |
| 14F0051                | Liechtenstein, Switzerland                                                                                                                                                                                                                                                                                                                                                                                                                                                                                                                                                                                      |
| 14F0069                | Chile, Ethiopia, Italy, Libya, Somalia                                                                                                                                                                                                                                                                                                                                                                                                                                                                                                                                                                          |
| 14F0087                | Israel                                                                                                                                                                                                                                                                                                                                                                                                                                                                                                                                                                                                          |
| 1838574                | Thailand                                                                                                                                                                                                                                                                                                                                                                                                                                                                                                                                                                                                        |
| 6952301                | Bahamas, Barbados, Bermuda, Bolivia, Brazil, Canada, Cayman Islands, Colombia, Costa Rica, Dominican Republic, Ecuador, El Salvador, Guatemala, Guyana, Haiti, Honduras, Jamaica, Japan, Korea (South), Liberia, Mexico, Netherlands Antilles, Nicaragua, Panama, Peru, Philippines, Saudi Arabia, Suriname, Taiwan, Trinidad (West Indies), United States of America, Venezuela                                                                                                                                                                                                                                |

Parent topic: [Part number catalog](#)

## Cannot power on SPCN-controlled I/O expansion unit

You are here because an SPCN-controlled I/O expansion unit cannot be powered on, and might be displaying a 1xxx-C62E reference code.

### **DANGER**When working on or around the system, observe the following precautions:

Electrical voltage and current from power, telephone, and communication cables are hazardous. To avoid a shock hazard:

- Connect power to this unit only with the provided power cord. Do not use the provided power cord for any other product.
- Do not open or service any power supply assembly.



- Do not connect or disconnect any cables or perform installation, maintenance, or reconfiguration of this product during an electrical storm.
- The product might be equipped with multiple power cords. To remove all hazardous voltages, disconnect all power cords.
- Connect all power cords to a properly wired and grounded electrical outlet. Ensure that the outlet supplies proper voltage and phase rotation according to the system rating plate.
- Connect any equipment that will be attached to this product to properly wired outlets.
- When possible, use one hand only to connect or disconnect signal cables.
- Never turn on any equipment when there is evidence of fire, water, or structural damage.
- Disconnect the attached power cords, telecommunications systems, networks, and modems before you open the device covers, unless instructed otherwise in the installation and configuration procedures.
- Connect and disconnect cables as described in the following procedures when installing, moving, or opening covers on this product or attached devices.

To Disconnect:

1. Turn off everything (unless instructed otherwise).
2. Remove the power cords from the outlets.
3. Remove the signal cables from the connectors.
4. Remove all cables from the devices

To Connect:

1. Turn off everything (unless instructed otherwise).
2. Attach all cables to the devices.
3. Attach the signal cables to the connectors.
4. Attach the power cords to the outlets.
5. Turn on the devices.

(D005)

1. Is the unit that is not powering on a shared unit that is switched to a system unit that does not have an SPCN frame-to-frame cable attached to it?
  - ◆ No: Continue with the next step.
  - ◆ Yes: The shared unit *must* be switched to a system unit with an SPCN frame-to-frame cable attached to it to service it. Do this and continue with the next step.
2. Power on the system.
3. Starting from SPCN 0 or SPCN 1 on the system unit, go to the first unit in the SPCN frame-to-frame cable sequence that does not power on. Is the Data display background light on, or is the power-on LED blinking, or are there any characters displayed on the I/O expansion unit display panel?

**Note:** The background light is a dim (yellow) light in the Data area of the display panel.

- ◆ Yes: Go to step 13.
  - ◆ No: Continue with the next step.
4. Use a multimeter to measure the ac voltage at the customer's ac power outlet.

Is the ac voltage from 200 V ac to 240 V ac, or from 100 V ac to 127 V ac?

- ◆ Yes: Continue with the next step.
- ◆ No: Inform the customer that the ac voltage at the power outlet is not correct.

This ends the procedure.

5. Is the mainline ac power cable from the ac module, battery charger, power supply, or power distribution unit to the customer's ac power outlet connected and seated correctly at both ends?
  - ◆ Yes: Continue with the next step.
  - ◆ No: Connect the mainline ac power cable correctly at both ends.

This ends the procedure.

6. Perform the following:
  - a. Disconnect the mainline ac power cable from the ac module, battery charger, power supply, or power distribution unit.

b. Use a multimeter to measure the ac voltage at the ac module, battery charger, power supply, or power distribution unit end of the mainline ac power cable.  
Is the ac voltage from 200 V ac to 240 V ac, or from 100 V ac to 127 V ac?

- ◆ No: Continue with the next step.
- ◆ Yes: Go to step 8.

7. Are you working on a power distribution unit with tripped breakers?

- ◆ No: Exchange the mainline ac power cable or power distribution unit (as installed).

This ends the procedure.

- ◆ Yes: Perform the following:
  - a. Reset the tripped power distribution breaker.
  - b. Verify that the removeable ac line cord is not the problem. Replace the cord, as installed, if it is defective.
  - c. Install a new power supply (as installed) in all power locations until the defective one is found.

This ends the procedure.

8. Does the unit you are working on have ac power jumper cables installed?

**Note:** The ac power jumper cables connect from the ac module, battery charger unit, or the power distribution unit to the power supplies.

- ◆ Yes: Continue with the next step.
- ◆ No: Go to step 12.

9. Are the ac power jumper cables connected and seated correctly at both ends?

- ◆ Yes: Continue with the next step.
- ◆ No: Connect the ac power jumper cables correctly at both ends.

This ends the procedure.

10. Perform the following:

- a. Disconnect the ac power jumper cables from the battery charger unit, ac module, or power distribution unit.
- b. Use a multimeter to measure the dc voltage at the battery charger unit outlets or ac voltage at the ac module and power distribution unit (that goes to the power supplies).

Is the dc voltage at the battery charger unit from 145 V dc to 259 V dc, or is the ac voltage at the ac module and power distribution unit from 200 V ac to 240 V ac?

- ◆ Yes: Continue with the next step.
- ◆ No: Exchange the following as they are installed (see [Part number catalog](#)):
  - ◇ Battery charger unit
  - ◇ AC module
  - ◇ Power distribution unit

This ends the procedure.

11. Perform the following:

- a. Connect the ac power jumper cables to the ac module, battery charger unit, or power distribution unit.
- b. Disconnect the ac power jumper cable at the power supplies.
- c. Use a multimeter to measure the voltage of the power jumper cables input to the power supplies.

Is the dc voltage from 145 V dc to 259 V dc (200 V ac to 240 V ac for dual line cord units and power distribution units) for each power jumper cable?

- ◆ No: Exchange the power jumper cable.

This ends the procedure.

- ◆ Yes: Exchange the following parts one at a time:
  - a. SPCN card unit (see [TWRCARD](#)).
  - b. Display unit (see [CTLPNL](#)).
  - c. Power supply 1 (see [Part number catalog](#))
  - d. Power supply 2 (see [Part number catalog](#))
  - e. Power supply 3 (see [Part number catalog](#))

This ends the procedure.

12. Perform the following:

- a. Disconnect the mainline ac power cable (to the expansion unit) from the customer's ac power outlet.
- b. Exchange one of the following FRUs:
  - ◇ SPCN card (see [TWRCARD](#)).
  - ◇ Power supply (see [Finding part locations](#)).
- c. Reconnect the mainline ac power cables (from the expansion unit) into the power outlet.
- d. Attempt to power on the system.

Does the expansion unit power on?

- ◆ Yes: The unit you exchanged was the failing item.

This ends the procedure.

- ◆ No: Repeat this step and exchange the next FRU in the list. If you have exchanged all of the FRUs in the list, ask your next level of support for assistance.

This ends the procedure.

13. Is there a reference code displayed on the display panel for the I/O unit that does not power on?

- ◆ Yes: Continue with the next step.
- ◆ No: Replace the SPCN card (see [TWRCARD](#)).

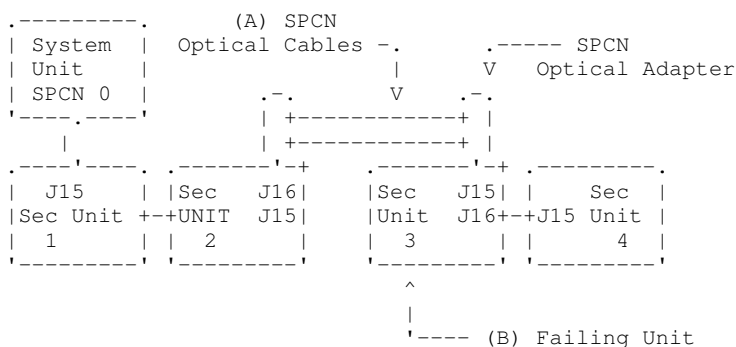
This ends the procedure.

14. Is the reference code 1xxx xx2E?

- ◆ Yes: Continue with the next step.
- ◆ No: Use the new reference code and return to [Start of call procedure](#).

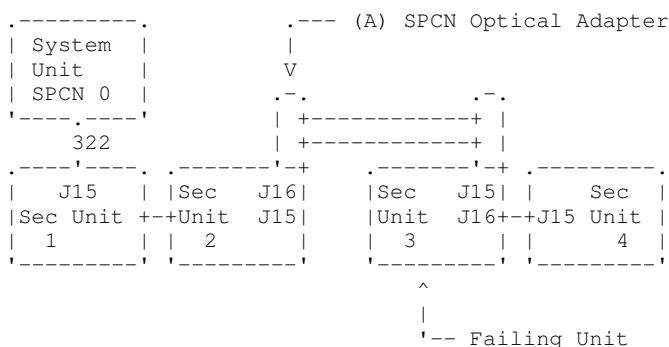
This ends the procedure.

15. Do the SPCN optical cables (A) connect the failing unit (B) to the preceding unit in the string or loop?



- ◆ Yes: Continue with the next step.
- ◆ No: Go to step 19.

16. Remove the SPCN optical adapter (A) from the preceding frame in the string that cannot become powered on (see [Removing and replacing parts](#)).



17. Perform the following:

**Notes:**

- a. The cable may be connected to either J15 or J16.
- b. Use an insulated probe or jumper when performing the voltage readings.

- a. Connect the negative lead of a multimeter to the system frame ground.
- b. Connect the positive lead of a multimeter to pin 2 of the connector from which you removed the SPCN optical adapter in the previous step of this procedure.
- c. Note the voltage reading on pin 2.
- d. Move the positive lead of the multimeter to pin 3 of the connector or SPCN card.
- e. Note the voltage reading on pin 3.

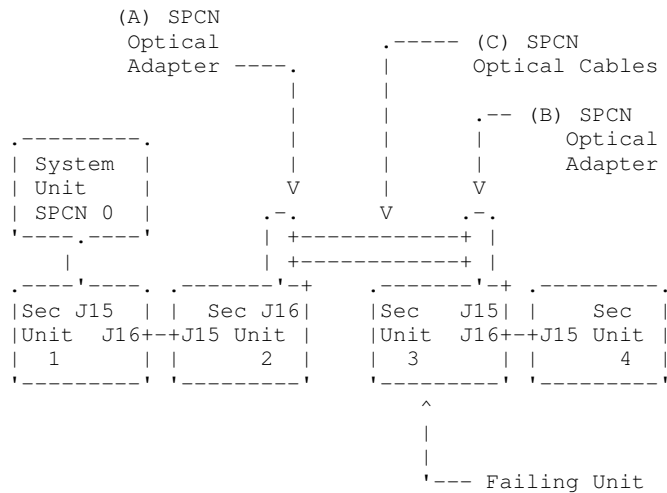
Is the voltage on both pin 2 and pin 3 from 1.5 V dc to 5.5 V dc?

- ◆ Yes: Continue with the next step.
- ◆ No: Exchange the SPCN card (see [TWRCARD](#)) in the unit from which you removed the SPCN optical adapter (see [Removing and replacing parts](#)).

This ends the procedure.

18. Exchange the following FRUs, one at a time (see [Removing and replacing parts](#)):
  - a. SPCN card (see [TWRCARD](#)) in the failing unit (first frame with a failure indication).
  - b. SPCN card (see [TWRCARD](#)) in the preceding unit in the string.
  - c. SPCN optical adapter (A) in the preceding unit in the string.
  - d. SPCN optical adapter (B) in the failing unit.
  - e. SPCN optical cables (C) between the preceding unit in the string and the failing unit.

This ends the procedure.



19. Perform the following:
  - a. Power off the system.
  - b. Disconnect the SPCN frame-to-frame cable from the connector of the first unit that cannot be powered on.
  - c. Connect the negative lead of a multimeter to the system frame ground.
  - d. Connect the positive lead of the multimeter to pin 2 of the SPCN cable.

**Note:** Use an insulated probe or jumper when performing the voltage readings.

- e. Note the voltage reading on pin 2.
- f. Move the positive lead of the multimeter to pin 3 of the SPCN cable.
- g. Note the voltage reading on pin 3.

Is the voltage on both pin 2 and pin 3 from 1.5 V dc to 5.5 V dc?

- ◆ No: Continue with the next step.
- ◆ Yes: Exchange the following FRUs one at a time (see [Removing and replacing parts](#)):
  - a. SPCN card (see [TWRCARD](#)) in the failing unit.
  - b. SPCN card (see [TWRCARD](#)) in the preceding unit in the unit string.
  - c. SPCN frame-to-frame cable.

This ends the procedure.

20. Perform the following:
  - a. Follow the SPCN frame-to-frame cable back to the preceding unit in the string.
  - b. Disconnect the SPCN cable from the connector.
  - c. Connect the negative lead of a multimeter to the system frame ground.
  - d. Connect the positive lead of a multimeter to pin 2 of the connector.

**Note:** Use an insulated probe or jumper when performing the voltage readings.

- e. Note the voltage reading on pin 2.
  - f. Move the positive lead of the multimeter to pin 3 of the connector.
  - g. Note the voltage reading on pin 3.
- Is the voltage on both pin 2 and pin 3 from 1.5 V dc to 5.5 V dc?

- ◆ Yes: Exchange the following FRUs one at a time (see [Removing and replacing parts](#)):
  - a. SPCN frame-to-frame cable.
  - b. SPCN card (see [TWRCARD](#)) in the failing unit.
  - c. SPCN card (see [TWRCARD](#)) in the preceding unit of the string.
 This ends the procedure.
- ◆ No: Exchange the SPCN card (see [TWRCARD](#)) from the unit from which you disconnected the SPCN cable in the previous step of this procedure. See [Removing and replacing parts](#).

This ends the procedure.

---

## Cannot power off system or SPCN-controlled I/O expansion unit

Use this procedure to analyze a failure of the normal command and control panel procedures to power off the system unit or an SPCN-controlled I/O expansion unit.

**Attention:** To prevent loss of data, ask the customer to verify that no interactive jobs are running before you perform this procedure.

### **DANGER**When working on or around the system, observe the following precautions:

Electrical voltage and current from power, telephone, and communication cables are hazardous. To avoid a shock hazard:

- Connect power to this unit only with the provided power cord. Do not use the provided power cord for any other product.
- Do not open or service any power supply assembly.
- Do not connect or disconnect any cables or perform installation, maintenance, or reconfiguration of this product during an electrical storm.
- The product might be equipped with multiple power cords. To remove all hazardous voltages, disconnect all power cords.
- Connect all power cords to a properly wired and grounded electrical outlet. Ensure that the outlet supplies proper voltage and phase rotation according to the system rating plate.
- Connect any equipment that will be attached to this product to properly wired outlets.
- When possible, use one hand only to connect or disconnect signal cables.
- Never turn on any equipment when there is evidence of fire, water, or structural damage.
- Disconnect the attached power cords, telecommunications systems, networks, and modems before you open the device covers, unless instructed otherwise in the installation and configuration procedures.
- Connect and disconnect cables as described in the following procedures when installing, moving, or opening covers on this product or attached devices.
  - To Disconnect:
    1. Turn off everything (unless instructed otherwise).
    2. Remove the power cords from the outlets.
    3. Remove the signal cables from the connectors.
    4. Remove all cables from the devices

## To Connect:

1. Turn off everything (unless instructed otherwise).
2. Attach all cables to the devices.
3. Attach the signal cables to the connectors.
4. Attach the power cords to the outlets.
5. Turn on the devices.

(D005)

1. Is the power off problem on the system unit?
  - ◆ No: Continue with the next step.
  - ◆ Yes: Go to step 3.
2. Ensure that the SPCN cables that connect the units are connected and seated correctly at both ends. Does the unit power off, and is the power indicator light blinking slowly?
  - ◆ Yes: This ends the procedure.
  - ◆ No: Go to step 7.
3. Attempt to power off the system (see [Stopping the system](#) in the [Installing hardware](#) topic). Does the system unit power off, and is the power indicator light blinking slowly?
  - ◆ No: Continue with the next step.
  - ◆ Yes: This ends the procedure.
4. Attempt to power off the system using ASMI (see [Powering the system on and off](#) in the [Advanced System Management Interface \(ASMI\)](#) topic). Does the system power off?
  - ◆ Yes: Continue with the next step.
  - ◆ No: Go to step 10.
5. Attempt to power off the system using the control panel power button (see [Using the control panel power button](#)). Does the system power off?
  - ◆ Yes: Go to step 6.
  - ◆ No: Continue with the next step.
6. Is the system HMC-managed?
  - ◆ Yes: Go to the [HMC isolation procedures](#). This ends the procedure.
  - ◆ No: Use ASMI to display error logs (see [Displaying error and event logs](#) in the [Advanced System Management Interface \(ASMI\)](#) topic) and service any errors you find. If you find no errors, or if you cannot access ASMI, then contact your next level of support. This ends the procedure.
7. Is the I/O expansion unit that will not power off part of a shared I/O tower loop?
  - ◆ Yes: Go to step 9.
  - ◆ No: Continue with the next step.
8. Attempt to power off the I/O expansion unit (see [Powering off an expansion unit](#)). Were you able to power off the expansion unit?
  - ◆ Yes: This ends the procedure.
  - ◆ No: Go to step 10.
9. The unit will only power off under certain conditions:
  - ◆ If the unit is in private mode, it should power off with the system unit that is connected by the SPCN frame-to-frame cable.
  - ◆ If the unit is in switchable mode, it should power off if the "owning" system is powered off or is powering off, and the system unit that is connected by the SPCN frame-to-frame cable is powered off or is powering off.
 Does the I/O expansion unit power off?
  - ◆ No: Continue with the next step.
  - ◆ Yes: This ends the procedure.
10. Ensure there are no jobs running on the system or partition, and verify that the battery power unit or uninterruptible power supply (UPS) is not powering the system or I/O expansion unit. Then continue with the next step.
11. Perform the following:
  - a. Remove the system or I/O expansion unit ac power cord from the external UPS or, if an external UPS is not installed, from the customer's ac power outlet. If the system or I/O expansion unit has more than one ac line cord, disconnect all the ac line cords.
  - b. Exchange the following FRUs one at a time (see [Removing and replacing parts](#) and [Part number catalog](#)).

If the system unit is failing:

- i. Power supply (see symbolic FRU [PWRSPLY](#))
- ii. System SPCN card (see symbolic FRU [TWRCARD](#))

iii. System control panel (see symbolic FRU [CTLPNL](#))

iv. Control panel cable

If an I/O expansion unit is failing:

i. Power supply (see symbolic FRU [PWRSPLY](#))

ii. Expansion SPCN card (see symbolic FRU [TWRCARD](#))

iii. SPCN card (see symbolic FRU [TWRCARD](#)) in the unit preceding the unit that will not power off

iv. Battery charger unit (see symbolic FRU [BATCHGR](#)), if installed

v. SPCN frame-to-frame cable

This ends the procedure.

---

## Powering off an expansion unit

**Attention:** Before beginning, read this entire procedure. If there are procedural steps that cannot be performed at this time, the procedure must be delayed until a later time.

**Attention:** If the server is HMC-managed, the power off and power on functions must be performed using the Power On/Off Unit utility on the HMC. To use the Power On/Off Unit utility, do the following when instructed to in the procedure below:

1. In the navigation area, open the Service Applications folder.
2. Select Service Focal Point.
3. In the contents area, select Service Utilities.
4. In the Service Utilities window, select the system you are working on.
5. Select Selected > Power On/Off Unit

If the server is not HMC-managed, the power off and power on functions must be performed using the Packaging Hardware Resources utility from the service partition. To use the Packaging Hardware Resources, go to the System Service Tools or the Dedicated Service Tools and do the following when instructed to in the procedure below:

1. Select Start a service tool
2. Select Hardware service manager
3. Select Packaging hardware resources
4. Select Concurrent maintenance

If the server is not HMC-managed and there is no service partition, the expansion unit cannot be powered off and on with the server powered on.

**Attention:** Do *not* use this procedure to replace disk units that are supported under device concurrent maintenance. Use the device concurrent maintenance procedure instead.

**Attention:** Do *not* use this procedure on the system unit or the system unit's integrated expansion unit. For system units and system units integrated expansion units see [Powering on and powering off](#)

**Notes:**

1. References to the console in this procedure refer to the console of the logical partition in which you are working.
2. Throughout this procedure, the term *HSL I/O bridge* is interchangeable with *RIO adapter*.
3. Throughout this procedure, the term *tower* is interchangeable with *expansion unit*.
4. Messages that may be generated on the HMC during the procedure refer to specific partitions by their partition IDs. A partition's ID is a numeric value that represents the order in which the partitions were created. The partitions listed in the Server Management content area are not necessarily listed in order of partition ID. A partition's ID is listed under the *General* tab in the Partition Properties.

Perform the following with the assistance of the customer:

1. If you have not already done so, record the expansion unit's location code and machine type-model-serial numbers (MTMS).
2. Can the expansion unit be powered off with the server powered on (the server is HMC-managed or has an service partition), and does the customer want to perform the procedure with the server powered on?
  - ◆ No: The expansion unit must be powered off by powering off the server. See [Powering on and powering off](#) for instructions on powering off the server, then return to the procedure that sent you here.
  - ◆ Yes: Go to [step 3](#).

**Note:** If the activated firmware level of the server to which the expansion unit is attached is lower than SF235, there is a small chance that bus numbers for the PCI buses in the expansion unit will change if the I/O backplane in the expansion unit is replaced with the server powered off. If this occurs on a server with multiple logical partitions, the I/O slot resources in the expansion unit will have to be reassigned to the appropriate partitions. Additionally, AIX logical resource names of the I/O resources in the expansion unit may change requiring some manual reconfiguration in the partition. If the I/O backplane is replaced with the server powered off, be prepared to perform these reconfiguration activities after the procedure. If the I/O backplane is replaced with the server powered on, either to firmware standby or firmware running, reconfiguration will not be required.

If it is desirable to replace the I/O backplane with the server powered off, but configuration changes cannot be tolerated, powering off the server and then powering it on to firmware standby state before performing the procedure might be a satisfactory alternative.

The activated firmware level of the server is displayed in the upper right corner of the ASMI utility.

3. Verify that the expansion unit being powered off is the correct one. If the expansion unit has an alphanumeric display on the control panel, verify that the type, model, and serial number of the expansion unit displayed on the user interface match that shown on the control panel display. Or activate the identify indicator on the expansion unit. To activate the identify indicator on the expansion unit, do the following:
  - ◆ From the HMC use: Service Focal Point > Service Utilities > Identify LED processing.
  - ◆ From use: System (or Dedicated) Service Tools > Start a service tool > Hardware service manager > Packaging hardware resources > Concurrent maintenance > Toggle LED blink off/on.
  - ◆ Are you powering off the correct expansion unit?
    - ◇ No: Choose the correct expansion unit. Then perform this procedure again.
    - ◇ Yes: Go to [step 4](#).
4. The system will not allow the expansion unit to be powered off if there are failed or inactive links in the HSL loop that the expansion unit is on, other than the links adjacent to the expansion unit. If an attempt is made to power off the expansion unit under these circumstances, a descriptive error message will be presented. Determine if there are failed or inactive links by following one of the following procedures: [Verify the RIO/HSL loop with a HMC](#) or [Verify the RIO/HSL loop without a HMC](#).

Are there external links that are not operational in the HSL loop, other than those adjacent to the expansion unit being powered off?

- ◆ No: Go to [step 5](#).



- ◆ Yes: Repair the failed or inactive links, except those adjacent to the expansion unit being powered off. If you need assistance, contact your service provider. Then perform this procedure again.
5. Verify that the SPCN loop is complete. A 10009135 reference code in the error log indicates an incomplete SPCN loop. A complete SPCN loop is not required, but is highly recommended. Powering off an expansion unit with an incomplete SPCN loop could cause lost contact with other expansion units on the SPCN loop. The expansion units that the system lost contact with will continue to function; however, the system may log additional errors and will not be able to monitor those units. Work with the customer to determine whether the SPCN loop is complete, whether correction is necessary, and then go to [step 6](#).
  6. If the system has only partitions running AIX or Linux, skip to [step 10](#), if not go to [step 7](#).
  7. The system will not allow the expansion unit to be powered off if the expansion unit is configured as switchable and the system that owns the HSL I/O bridge (the logical owner of the expansion unit) is not the system that provides power to the expansion unit (the system whose SPCN the expansion unit resides in, or SPCN system). If an attempt is made to power off the expansion unit under these circumstances, a descriptive error message will be presented. Determine if the expansion unit is configured as a switchable unit, either by asking the customer or referring to [Determining if a tower is configured as switchable under OptiConnect](#).

**Note:** Switchable expansion units will exist only if the server makes use of Switchable Independent Disk Pools.

Is the expansion unit configured as switchable?

- ◆ No: The expansion unit is configured as private to this system. Go to [step 10](#).
  - ◆ Yes: Go to [step 8](#).
8. Determine if the logical owner of the expansion unit is the SPCN system by asking the customer or referring to [Determining if a tower is configured as switchable under OptiConnect](#).

Is the logical owner of the expansion unit also the SPCN system?

- ◆ No: Work with the customer to switch logical ownership of the HSL I/O bridge in the expansion unit to the SPCN system. This should be done using the OptiConnect user interface. If that is not successful due to problems with the OptiConnect user interface, it may be attempted as described in [Switching ownership of a tower's switchable resources](#), however, this should be used only as a last resort since it may result in Cluster Resource Group (CRG) problems. If the switch cannot be performed, contact your service provider for assistance. Otherwise, continue with [step 9](#) from the SPCN system.
  - ◆ Yes: Go to [step 9](#).
9. The system will not allow the expansion unit to be powered off if it contains resources included in an active Cluster Resource Group (CRG). If an attempt is made to power off the expansion unit under these circumstances, a descriptive error message will be presented. Determine if the expansion unit contains resources included in an active CRG by asking the customer.

Does the expansion unit contain resources included in an active CRG?

- ◆ No: Go to [step 10](#).
  - ◆ Yes: Work with the customer to end each active CRG that contains resources in the expansion unit.
10. Determine if any of the I/O resources in the expansion unit are owned by partitions running Linux.

Are any of the I/O resources in the expansion unit owned by partitions running Linux?

- ◆ No: Go to [step 11](#).
  - ◆ Yes: Power off the partitions running Linux and go to [step 11](#).
11. Determine if any of the I/O resources in the expansion unit are owned by partitions running AIX. Are any of the I/O resources in the expansion unit owned by partitions running AIX?
    - ◆ No: Go to [step 12](#).
    - ◆ Yes: Do the partitions have a code level that supports the powering off and on of an expansion unit with the partition running? The required level for AIX 5.2 is 5.2.0.61 or later and the required level for AIX 5.3 is 5.3.0.22 or later. You can determine the level of AIX by invoking the command `lspp -l devices.chrp.base.rte` from the AIX command line.

- ◇ Yes: Does the HMC have a code level that supports power off and on of an expansion unit with I/O resources assigned to active partitions running AIX? The required HMC code level is version 4, release 5.0 or later. You can view the HMC code level by accessing: Licensed Internal Code Maintenance > HMC Code Update. The code level appears in the content area.
    - Yes: Go to [step 12](#).
    - No: Power off the partitions that are running AIX and that own I/O resources in the expansion unit, then go to [step 12](#).
  - ◇ No: Power off the partitions that are running AIX and that own I/O resources in the expansion unit, then go to [step 12](#).
12. Work with the customer to end I/O activity to the expansion unit by performing the following. If all partitions that own I/O resources in the expansion unit have been powered off, skip this step and go to [step 13](#).

◆ In partitions:

- ◇ Work with the customer to vary off all configuration descriptions (for example, ctl, device, line, network server, etc.) that use resources in the expansion unit. This can be done using the `vrycfg` command. The system will not allow the expansion unit to be powered off unless all configuration descriptions that use resources in the expansion unit are varied off. If an attempt is made to power off the expansion unit when there are configuration descriptions that use resources in the expansion unit that are varied on, a descriptive error message will be presented.

**Note:** If configuration descriptions that use resources in the expansion unit cannot be varied off, the procedure must be delayed until they can be varied off or the partitions that have such configuration descriptions must be powered off.

- ◇ If the expansion unit contains disk unit IOPs and/or IOAs, and the disk units are not mirrored to disk units in other expansion towers, work with the customer to end all communications activities to these disk units by ending all subsystems.

**Note:** The system allows you to power off the expansion unit even if this is not done, however, doing so may result in a disk unit attention SRC and a partial or complete hang of the partition until the expansion unit is powered on.

- ◇ If the expansion tower contains disk unit IOPs and/or IOAs and these disk units are mirrored to disk units in other expansion towers, you do not need to end all subsystems. Mirroring will assist during the service action.

◆ In AIX partitions:

- ◇ Work with the customer to unconfigure all logical device resources that use resources in the expansion unit. This can be done using the `rmdev` command. The system will not allow the expansion unit to be powered off unless all logical device resources that use resources in the expansion unit are unconfigured. If an attempt is made to power off the expansion unit when there are logical device resources that use resources in the expansion unit that are not unconfigured, a descriptive error message will be presented.
- ◇ If logical device resources that use resources in the expansion unit cannot be unconfigured, the procedure must be delayed until they can be unconfigured or the partitions that have such resources must be powered off.
- ◇ Following is an example of the type of message that is displayed if there are logical AIX resources that must be unconfigured. It shows two messages. The first indicates that logical device resource `pci11` with physical name `U5294.001.23B2424-CB1-C01` must be unconfigured. To unconfigure this resource invoke the AIX command `rmdev -R -l pci11`. The second indicates that logical device resources `pci6` and `ent0` with physical name `U0595.001.435DF30-CB1-C02` must be unconfigured. To unconfigure these resources invoke the AIX command `rmdev -R -l pci6`.

```
Reporting partition type: RPA
```

```
Return code type: Failure (hard stop or user intervention required).
```

```
Message:
```

## Service provider information

```
com.ibm.hsc.client.rmc.HSCRMCEException: Query operation for slot resource has failed on partition 2.
```

The partition command is:

```
drmgr -Q -c slot -s U5294.001.23B2424-CB1-C01 -w 0 -d 3
```

The partition standard output is:

```
drsloc_chrp_slot: slot_type=1 all slots=0x20042d68
```

The partition standard error is:

```
0931-029 The specified slot contains a device or devices that are currently configured. Unconfigure the following device or devices and try again.
```

```
pcill
```

The RMC return code is 0. The AIX return code is 1.

Reporting partition type: RPA

Return code type: Failure (hard stop or user intervention required).

Message:

```
com.ibm.hsc.client.rmc.HSCRMCEException: Query operation for slot resource has failed on partition 2.
```

The partition command is:

```
drmgr -Q -c slot -s U0595.001.435DF30-CB1-C02 -w 0 -d 3
```

The partition standard output is:

```
drsloc_chrp_slot: slot_type=1 all slots=0x20042ca8
```

The partition standard error is:

```
0931-029 The specified slot contains a device or devices that are currently configured. Unconfigure the following device or devices and try again.
```

```
ent0
```

```
pci6
```

The RMC return code is 0. The AIX return code is 1.

- ◇ The following AIX commands are helpful in determining which logical device resources use an expansion unit. In the following examples, U0595.001.435DF30 is the location code of the expansion unit being powered off.

Displays information about logical device resource pci5:

```
lscfg -l pci5
```

Displays all logical resources in U0595.001.435DF30:

```
lscfg | grep U0595.001.435DF30
```

```
* pci5          U0595.001.435DF30-CB1          PCI Bus
+ sisioa0       U0595.001.435DF30-CB1-C01          PCI-X Dual Channel U320 SCSI RAID A
+ scsi0         U0595.001.435DF30-CB1-C01-T1      PCI-X U320 SCSI RAID Adapter Physi
+ hdisk0        U0595.001.435DF30-CB1-C01-T1-L6-L0 16 Bit LVD SCSI Disk Drive (36400 M
* ses0         U0595.001.435DF30-CB1-C01-T1-L15-L0 SCSI Enclosure Services Device
+ scsil         U0595.001.435DF30-CB1-C01-T2      PCI-X U320 SCSI RAID Adapter Physi
+ sisraid0      U0595.001.435DF30-CB1-C01-C1-T1    PCI-X U320 SCSI RAID Adapter Logica
```

Displays the rootvg hdisk(s):

```
lsvg -o
```

- ◇ The resources representing the partition's LAN connection to the HMC, such as ent0 and en0, must not be unconfigured or the procedure will not work. If these resources use the expansion unit, the partition must be powered off to continue with the procedure.

**Attention:** If resources in the expansion unit are assigned to I/O server partitions and are being used by I/O server partitions (also known as virtual I/O servers), work with the customer to determine whether powering off the expansion unit will negatively impact the client partitions. If so, the client partitions should be powered off before continuing.

13. Power off all external DVD-RAM storage devices (containing their own power supplies) connected to resources in the expansion unit, then go to [step 14](#).
14. Power off the expansion unit using either the "Power On/Off Unit" utility from the HMC, or the "Packaging Hardware Resources" utility from the service partition, as described at the top of this page. Carefully follow the instructions provided by the utility to complete the power off.

**Notes:**

- a. If the procedure is being done from an partition, the system will not allow it to be done from a console or terminal session connected through the expansion unit being powered off. A different console or terminal session not connected through the expansion unit being powered off must be found, or the server must be powered off. See [Powering on and powering off](#) for instruction on powering off the server, then return to the procedure that sent you here.
  - b. If I/O activity to resources in the expansion unit was not ended as described in [step 12](#), the power off will not be allowed and messages will be presented indicating which partition resources need to be varied off or unconfigured. Similarly for other conditions described previously in this page that prevent the power off.
  - c. Carefully follow all instructions given by the utility. For instance, you may be informed that critical disk resources exist in the expansion unit and that panel function 69 must be used to power the expansion unit back on.
  - d. Wait for the expansion unit to power off. This might take up to 15 minutes depending on the configuration.
  - e. When the utility gives notification that the power off has completed, ensure that the expansion unit is actually powered off by verifying that one of the two air moving devices (AMDs) in the expansion tower has stopped and that the power LED/indicator on the expansion unit control panel is off.
  - f. If the expansion unit does not power off after more than 15 minutes, the system may be hung. If this occurs, contact your service provider for assistance.
15. Were you directed here to power off the expansion unit to set the expansion unit configuration ID or the machine type-model-serial numbers (MTMS)?
    - ◆ No: Go to [step 16](#).
    - ◆ Yes: Return to the procedure that sent you here.
  16. Does the procedure that sent you here instruct you to remove the ac power from the expansion unit?
    - ◆ No: Return to the procedure that sent you here.
    - ◆ Yes: Go to [step 17](#).
  17. Is this an expansion unit with ac power cords connected from this unit's ac input/charger to an SPCN controlled expansion unit (for example: a 5088 expansion I/O unit)?
    - ◆ No: This expansion unit can be serviced without affecting an SPCN controlled expansion unit. Return to the procedure that sent you here.
    - ◆ Yes: Servicing this expansion unit may affect an SPCN controlled expansion unit that is receiving ac power from this tower. Go to [step 18](#).
  18. You may be able to maintain ac power to the expansion unit that is receiving ac power from this expansion unit and remove power from this expansion unit so that you can service it. The following steps will help you to determine what you can do. Were you directed to this procedure as part of a procedure to exchange the ac input/charger, any of the device boards, or the power board?
    - ◆ No: You can maintain ac power to the expansion unit receiving ac power from this expansion unit while you are servicing this expansion unit. When the expansion unit is powered off, open the rear cover and trace the ac jumper cords from the three power supplies to the ac input charger. Then disconnect them at the ac charger. Power is now removed from the components that you will be working with or near. Return to the procedure that sent you here.
    - ◆ Yes: You must search for an alternate ac power source for the expansion unit receiving ac power from this expansion unit. Go to [step 19](#).
  19. Can you find an alternate ac power source for the expansion unit that is receiving ac power from this expansion unit?
    - ◆ No: You must power off the system to service this expansion unit. See [Powering on and powering off](#) for instructions on powering off the system, then return to the procedure that sent you here.
    - ◆ Yes: Move each of the expansion unit's ac power cords one at a time to the alternate ac power source to prevent the expansion unit from losing ac power. Return to the procedure that sent you here.

Parent topic: [Powering on and powering off](#)

---

## BATCHGR

A battery power unit charger is the failing item.

Exchange the battery power unit charger. See [Part number catalog](#).

**Note:** When a part number is displayed on the control panel of a system or expansion unit, replace that part first.

**This ends the procedure.**

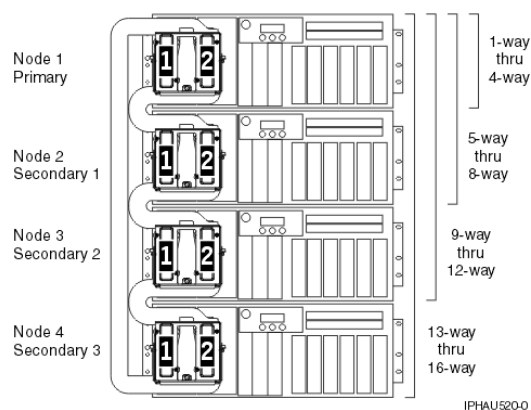
**Parent topic:** [Symbolic FRUs](#)

## Isolating problems

Provides procedures for determining which part or assembly is failing.

This topic will help you identify and isolate the problem the server is experiencing. You will be directed to information about how to resolve the issue.

**Note:** To simplify this information, secondary units on the ESCALA PL 850R/PL 1650R/R+ server are numbered 1 through 3-secondary unit 1 being nearest to the primary unit and secondary unit 3 being furthest.



- **Isolation procedures**  
Use the procedures in this topic to isolate the problem.
- **Collect serviceable events in IVM**  
Use this procedure when using Integrated Virtualization Manager (IVM) to check for serviceable events on your system.
- **AIX fast-path problem isolation**  
Use this information to help you isolate a hardware problem and the server is running the AIX operating system.
- **Linux fast-path problem isolation**  
Use this information to help you isolate a hardware problem when using the Linux operating system.
- **HMC isolation procedures**  
Use this information to diagnose and repair problems that are related to the Hardware Management Console (HMC).
- **Using failing item codes**  
This information is a list of failing item codes.
- **Symbolic FRUs**  
This information is a list of symbolic field replaceable units (FRUs).
- **Failing Function Codes (FFCs)**  
Failing function codes represent functions within the system unit.

**Parent topic:** [Service provider information](#)

## Isolation procedures

Use the procedures in this topic to isolate the problem.

- **Bus, high-speed link (HSL or RIO) isolation procedures**  
Symbolic FRUs, failing items (FIs), and bus isolation procedures use the terms "partition" and "logical partition" to indicate any single partition in a system that has multiple partitions. If the system you are working on does not have multiple partitions, then the terms refer to the primary partition.
- **Communication isolation procedure**  
This topic contains the procedure necessary to isolate a communications failure. Please read and observe the following warnings when using this procedure.
- **Disk unit isolation procedure**  
This topic contains the procedure to isolate a failure in a disk unit.
- **High performance switch (HPS) isolation procedures**  
Contains the procedures necessary to isolate a high performance switch (HPS) failure.
- **Intermittent isolation procedures**  
These procedures help you to correct an intermittent problem.
- **I/O processor (IOP) isolation procedures**  
Use these procedures to isolate a failure in the multiple function I/O card.
- **Licensed internal code (LIC) isolation procedures**  
Use this section to isolate licensed internal code (LIC) problems.
- **Logical partition (LPAR) isolation procedure**  
These procedures help you to identify logical partition (LPAR) configuration conditions and the associated corrective actions.
- **Operations Console isolation procedures**  
These procedures help you to isolate a failure with the Operations Console.
- **Power isolation procedures**  
Contains procedures for isolating a problem in the power system.
- **Router isolation procedures**  
These procedures serve as a guide to the correct isolation procedures from the reference code tables.
- **Service processor isolation procedures**  
These procedures help you to isolate problems with the service processor.
- **Tape unit isolation procedures**  
This topic contains the procedures necessary to isolate a failure in a tape device.
- **Twinaxial workstation I/O processor isolation procedure**  
Use the procedure below to isolate a failure which has been detected by the twinaxial workstation I/O processor. If you are using a personal computer, an emulation program must be installed and working.
- **Workstation adapter isolation procedure**  
Contains the procedure necessary to isolate a failure that is detected by the workstation adapter, and is used when no display is available with which to perform on-line problem analysis.
- **Workstation adapter console isolation procedure**  
Contains the procedure necessary to isolate a failure that is detected by the workstation adapter console.

Parent topic: [Isolating problems](#)

---

### Bus, high-speed link (HSL or RIO) isolation procedures

Symbolic FRUs, failing items (FIs), and bus isolation procedures use the terms "partition" and "logical partition" to indicate any single partition in a system that has multiple partitions. If the system you are working on does not have multiple partitions, then the terms refer to the primary partition.

Please read all safety notices below before servicing the system and while performing a procedure.

**Note:** Unless instructed otherwise, always power off the system before removing, exchanging, or installing a field-replaceable unit (FRU).

**DANGER** When working on or around the system, observe the following precautions:

Electrical voltage and current from power, telephone, and communication cables are hazardous. To avoid a shock hazard:

- Connect power to this unit only with the provided power cord. Do not use the provided power cord for any other product.
- Do not open or service any power supply assembly.
- Do not connect or disconnect any cables or perform installation, maintenance, or reconfiguration of this product during an electrical storm.
- The product might be equipped with multiple power cords. To remove all hazardous voltages, disconnect all power cords.
- Connect all power cords to a properly wired and grounded electrical outlet. Ensure that the outlet supplies proper voltage and phase rotation according to the system rating plate.
- Connect any equipment that will be attached to this product to properly wired outlets.
- When possible, use one hand only to connect or disconnect signal cables.
- Never turn on any equipment when there is evidence of fire, water, or structural damage.
- Disconnect the attached power cords, telecommunications systems, networks, and modems before you open the device covers, unless instructed otherwise in the installation and configuration procedures.
- Connect and disconnect cables as described in the following procedures when installing, moving, or opening covers on this product or attached devices.
  - To Disconnect:
    1. Turn off everything (unless instructed otherwise).
    2. Remove the power cords from the outlets.
    3. Remove the signal cables from the connectors.
    4. Remove all cables from the devices

To Connect:

1. Turn off everything (unless instructed otherwise).
2. Attach all cables to the devices.
3. Attach the signal cables to the connectors.
4. Attach the power cords to the outlets.
5. Turn on the devices.

(D005)

The following information provides tools and background needed to work through the isolation procedures:

- [Breaking down a RIO/HSL or PCI bus reference code](#)
- [DSA translation](#)
- [Card positions](#)
- [Converting the loop number to NIC port location labels](#)
- [PCI bus isolation using AIX, Linux, or the HMC](#)
- [Verifying a high-speed link, system PCI bus, or a multi-adapter bridge repair](#)
- [HSL loop configuration and status form](#)
- [Installed features in a PCI bridge set form](#)
- [RIO/HSL link status diagnosis form](#)

**CONSL01****HSL/RIO isolation procedures**

- [RIOIP01](#)
- [RIOIP02](#)
- [RIOIP03](#)
- [RIOIP04](#)
- [RIOIP06](#)
- [RIOIP07](#)
- [RIOIP08](#)
- [RIOIP09](#)
- [RIOIP10](#)
- [RIOIP11](#)

- [RIOIP12](#)
- [RIOIP50](#)
- [RIOIP55](#)

## IOP bus isolation procedures

- [MABIP05](#)
- [MABIP06](#)
- [MABIP07](#)
- [MABIP50](#)
- [MABIP51](#)
- [MABIP52](#)
- [MABIP53](#)
- [MABIP54](#)
- [MABIP55](#)

## Multi-adapter bridge (MAB) isolation procedures

- [MABIP02](#)
- [MABIP03](#)
- [MABIP04](#)

Parent topic: [Isolation procedures](#)

---

## CONSL01

Use this procedure to exchange the I/O processor (IOP) for the system or partition console of .

1. Is the system managed by an HMC?
  - ◆ No: Go to step 6.
  - ◆ Yes: The HMC will be required for this procedure. Move to the HMC and continue with the next step only if the HMC is functional.
2. Can the customer power off the partition at this time?
  - ◆ Yes: Power off the partition from the operating system console or the HMC. Then, continue with the next step.
  - ◆ No: The IOP controlling the partition's console may be controlling other critical resources. The partition must be powered off to exchange this IOP. Perform this procedure when the customer is able to power off the partition. Then, continue with the next step.
3. Perform the following to determine the unit machine type, model, and serial number where the console IOP is located and the location of the console IOP:
  - a. From the *Navigation Area* of the HMC, select the Management Environment.
  - b. Select and expand the HMC environment for this HMC.
  - c. Select and expand Server and Partition.
  - d. Select Server Management.
  - e. Double-click the partition you are working on.
  - f. Select the Settings tab.
  - g. Record the location of the load source IOP. The unit type, model, and serial number are the first three parts of the location code and are separated by periods.
  - h. Continue with the next step.
4. Record the frame type or feature by using the frame ID and system configuration listing or by locating the frame with that ID and recording the frame type or feature.
5. Perform the following to exchange the IOP in that card position:
  - a. Go to [Finding part locations](#) and select the unit type and model that you recorded.
  - b. Locate the card position in the FRU locations table and use the exchange procedure that is identified.



c. Power on the partition.

This ends the procedure.

6. The problem is in the partition of a system with one or more partitions that is not managed by an HMC. Use the table below to determine the location of the load source IOP and the appropriate exchange procedure.

| Model                      | Load source IOP location | Load source IOA location | Link to locations information.                                             |
|----------------------------|--------------------------|--------------------------|----------------------------------------------------------------------------|
| ESCALA PL 250T/R           | -P1-C5                   | embedded SCSI in -P1     | <a href="#">Locations</a> <a href="#">Model ESCALA PL 250T/R</a>           |
| ESCALA PL 450T/R, 7/20     | -P1-C1                   | embedded SCSI in -P1     | <a href="#">Locations</a> <a href="#">models ESCALA PL 450T/R</a>          |
| ESCALA PL 850R/PL 1650R/R+ | -P1-C1                   | embedded SCSI in -P1     | <a href="#">Locations</a> <a href="#">Model ESCALA PL 850R/PL 1650R/R+</a> |

This ends the procedure.

## RIOIP01

Use this procedure to isolate a failure in a high-speed link (HSL) loop using service tools.

Follow the steps in the [Main task](#) and you will be directed to the proper subtasks.

**Note:** During this procedure, you will be disconnecting and reconnecting cables. If errors concerning missing resources (such as disk units and HSL failures) occur, ignore them. Missing resources will report in again when the loop reinitializes.

### Main task

1. Were you directed here while working on a B700 xxxx reference code?
  - ◆ Yes: Go to step 4.
  - ◆ No: Continue with the next step.
2. Are you work on an ESCALA PL 250T/R or 5/70?
  - ◆ No: Go to step 4.
  - ◆ Yes: Continue with the next step.
3. Were you sent here from a B600 xxxx reference code?
  - ◆ No: Continue with the next step.
  - ◆ Yes: Use the serviceable event view and the system service documentation to search for a B700 xxxx reference code with the same last four characters reported at approximately the same time. If you find one, perform service on that reference code first, and when you close that problem, close this one as well. If you do not find one, continue with the next step.
4. Before powering down any system unit or expansion unit, work with the customer to end all subsystems in all of the partitions using each partition's console.
5. From the partition control panel, IPL the system or partition to Dedicated Service Tools (DST).

**Attention:** Do not use function 21!

6. Are all system and expansion units on the loop powered on?

- ◆ Yes: Go to step 8.
  - ◆ No: Continue with the next step.
7. Perform the following:
- a. Power on all system and expansion units on the loop. If a frame cannot be powered on, perform the [Cannot power on unit](#) subtask below, and then continue with step 8.
  - b. Was the HSL link error cleared up when the frames were powered back on?
    - ◇ No: Continue with the next step.
    - ◇ Yes: Go to [Verifying the repair](#).
- This ends the procedure.
8. Perform the following:
- a. Access the Service Action Log (SAL) entry for this error; the field replaceable units (FRUs) should be listed there. Look for part numbers and descriptions for the FRUs containing the HSL port for two frames. There should also be a FRU for the cable between them. The locations information for the FRUs is the location of the failed ports on the failed link.
  - b. Record the loop number from the SAL (if it is displayed there in one of the FRU descriptions) or from the first four characters of word 7 of the reference code. Go to [Converting the loop number to NIC port location labels](#) to determine which HSL/RIO cables on the system you are working with.
- Is this information in the SAL?
- ◇ Yes: Continue with the next step.
  - ◇ No: Perform [Manually detecting the failed link](#) below, and then continue with the next step of the main task.
9. Is the cable connecting the failed ports an optical cable?
- ◆ No: Go to step 11.
  - ◆ Yes: Continue with the next step.
10. Perform the following:
- a. Clean the HSL cable connectors and ports using the tools and procedures in symbolic FRU [OPT\\_CLN](#).
  - b. To determine if cleaning the connectors and ports solved the problem, perform [Manually detecting the failed link](#) below and return to this point. Did the ports you were working on have a status of "failed"?
    - ◇ No: Then the problem is fixed, go to [Verifying the repair](#). This ends the procedure.
    - ◇ Yes: Continue with the next step.
11. There are now three cases to consider. Continue with the appropriate subtask of this procedure:
- ◆ [The ports on both ends of the failed link are in different system units on the loop.](#)
  - ◆ [The port on one end of the failed link is in a system unit and the port on the other end is in an I/O unit.](#)
  - ◆ [The ports on both ends of the failed link are in an I/O unit.](#)

**The ports on both ends of the failed link are in different system units on the loop**

1. There may be failed hardware that will report a different error on the other system units. Perform the following:
  - a. Work any other HSL/RIO problems in the serviceable event view on the other system units.
  - b. Perform [Manually detecting the failed link](#) below and return to this point. Did the ports you were working on have a status of "failed"?
    - ◇ No: Then the problem is fixed, go to [Verifying the repair](#). This ends the procedure.
    - ◇ Yes: Continue with the next step.
2. Is the cable an optical HSL/RIO cable?
  - ◆ Yes: Go to step 4.
  - ◆ No: Continue with the next step.
3. Perform the following:
  - a. Check the thumb screws on the cable connectors at both ends of the cable to be sure they are tight. For any thumb screw that was loose, disconnect the cable at that end, wait 30 seconds, reconnect the cable, and tighten the thumb screws. You must tighten both thumb screws within 30 seconds of when the cable makes contact with the port.
  - b. If you disconnected and reconnected the cable at either end, perform [Manually detecting the failed link](#) below and return to this point. Did the ports you were working on have a status of "failed"?
    - ◇ No: Then the problem is fixed, go to [Verifying the repair](#). This ends the procedure.
    - ◇ Yes: Continue with the next step.
4. Replace the cable between the two system unit ports on the failed link. To determine if replacing the cable resolved the problem, perform [Manually detecting the failed link](#) below and return to this point.

Did the ports you were working on have a status of *"failed"*?

- ◆ No: Then the problem is fixed, go to [Verifying the repair](#). This ends the procedure.
  - ◆ Yes: Continue with the next step.
5. Exchange the FRU with the HSL/RIO port in one of the system units. If you are working with a serviceable event view and the HSL FRUs are listed, exchange the FRU corresponding to the first HSL/RIO cable port listed. Otherwise, exchange the FRU that is quickest and easiest to replace). To determine if replacing the FRU resolved the problem, perform [Manually detecting the failed link](#) below and return to this point. Did the ports you were working on have a status of *"failed"*?
    - ◆ No: Then the problem is fixed, go to [Verifying the repair](#). This ends the procedure.
    - ◆ Yes: Continue with the next step.
  6. Exchange the remaining FRU with the HSL/RIO port on the other system unit. To determine if replacing the FRU resolved the problem, perform [Manually detecting the failed link](#) below and return to this point. Did the ports you were working on have a status of *"failed"*?
    - ◆ No: Then the problem is fixed, go to [Verifying the repair](#). This ends the procedure.
    - ◆ Yes: Continue with the next step.
  7. Use symbolic FRU [HSL\\_LNK](#) to determine if there are any additional HSL/RIO cable-related FRUs, such as interposer cards and internal ribbon cables, that may be on either unit. Did you exchange any additional HSL/RIO FRUs?
    - ◆ No: Call your next level of support for further instruction. This ends the procedure.
    - ◆ Yes: Continue with the next step.
  8. To determine if replacing the FRU resolved the problem, perform [Manually detecting the failed link](#) below and return to this point. Did the ports you were working on have a status of *"failed"*?
    - ◆ No: Then the problem is fixed, go to [Verifying the repair](#). This ends the procedure.
    - ◆ Yes: Call your next level of support for further instruction. This ends the procedure.

**The port on one end of the failed link is in a system unit and the port on the other end is in an I/O unit**

1. Switch the two HSL/RIO cables on the I/O unit with the failed port, so that each cable is connected to the port where the other cable was previously connected. Disconnect both cables at the same time, wait 30 seconds, and then reconnect the cables one at a time.

**Attention:** For copper cables, you must fully connect the cable and tighten the connector's screws within 30 seconds of when the cable makes contact with the port. Otherwise, the link will fail and you must disconnect and reconnect again. Also, if the connector screws are not tightened, errors will occur on the link and it will fail.

2. Refresh the port status for the first failing resource by performing [Refresh the port status](#) below. Then continue with the next step.
3. Is the port on the system unit that was failed now working?
  - ◆ No: Continue with the next step.
  - ◆ Yes: Perform symbolic FRU [SIOADP](#) to exchange the HSL I/O bridge FRU in the I/O unit. Go to [Verifying the repair](#). This ends the procedure.
4. Switch the cables back to their original positions by disconnecting both cables at the same time, waiting 30 seconds, and then reconnecting the cables one at a time.

**Attention:** For copper cables, you must fully connect the cable and tighten the connector's screws within 30 seconds of when the cable makes contact with the port. Otherwise, the link will fail and you must disconnect and reconnect again. Also, if the connector screws are not tightened, errors will occur on the link and it will fail.

5. Refresh the port status for the first failing resource by performing [Refresh the port status](#) below. Then continue with the next step.
6. Exchange the cable between the two ports on the failed link. To determine if replacing the cable resolved the problem, perform [Manually detecting the failed link](#) below and return to this point. Did the ports you were working on have a status of *"failed"*?
  - ◆ No: Then the problem is fixed, go to [Verifying the repair](#). This ends the procedure.
  - ◆ Yes: Continue with the next step.
7. Exchange the HSL/RIO FRU that contains the failing port in the system unit. To determine if replacing the FRU resolved the problem, perform [Manually detecting the failed link](#) below and return to this point. Did the ports you were working on have a status of *"failed"*?

- ◆ No: Then the problem is fixed, go to [Verifying the repair](#). This ends the procedure.
  - ◆ Yes: Continue with the next step.
8. Use symbolic FRU [HSL\\_LNK](#) to determine if there are any additional HSL/RIO cable-related FRUs, such as interposer cards and internal ribbon cables, that may be on either unit. Did you exchange any additional HSL/RIO FRUs?
    - ◆ No: Call your next level of support for further instruction. This ends the procedure.
    - ◆ Yes: Continue with the next step.
  9. To determine if replacing the FRU resolved the problem, perform [Manually detecting the failed link](#) below and return to this point. Did the ports you were working on have a status of *"failed"*?
    - ◆ No: Then the problem is fixed, go to [Verifying the repair](#). This ends the procedure.
    - ◆ Yes: Call your next level of support for further instruction. This ends the procedure.

**The ports on both ends of the failed link are in an I/O unit**

1. Switch the two HSL/RIO cables on the first (or "From") cable's I/O unit with the failed port so that each cable is connected to the port where the other cable was previously connected.

**Attention:** For copper cables, you must fully connect the cable and tighten the connector's screws within 30 seconds of when the cable makes contact with the port. Otherwise, the link will fail and you must disconnect and reconnect again. Also, if the connector screws are not tightened, errors will occur on the link and it will fail.

2. Refresh the port status for the first failing resource by performing [Refresh the port status](#) below. Then continue with the next step.
3. Is the port on the I/O unit on which you did not switch the cables now working?
  - ◆ No: Go to step 5
  - ◆ Yes: Use symbolic FRU [SIIOADP](#) to exchange the HSL/RIO I/O bridge card in the I/O unit where you just switched the cables. Then continue with the next step.
4. To determine if replacing the FRU resolved the problem, perform [Manually detecting the failed link](#) and return to this point. Did the ports you were working on have a status of *"failed"*?
  - ◆ No: Then the problem is fixed, go to [Verifying the repair](#). This ends the procedure.
  - ◆ Yes: Continue with the next step.
5. Switch the cables back to their original positions.

**Attention:** For copper cables, you must fully connect the cable and tighten the connector's screws within 30 seconds of when the cable makes contact with the port. Otherwise, the link will fail and you must disconnect and reconnect again. Also, if the connector screws are not tightened, errors will occur on the link and it will fail.

6. Switch the two HSL/RIO cables on the second (or "To") I/O unit with the failed port so that each cable is connected to the port where the other cable was previously connected.

**Attention:** For copper cables, you must fully connect the cable and tighten the connector's screws within 30 seconds of when the cable makes contact with the port. Otherwise, the link will fail and you must disconnect and reconnect again. Also, if the connector screws are not tightened, errors will occur on the link and it will fail.

7. Refresh the port status for the first failing resource by performing [Refresh the port status](#). Then continue with the next step.
8. Is the port on the I/O unit on which you did not switch cables now working?
  - ◆ No: Go to step 10.
  - ◆ Yes: Use symbolic FRU [SIIOADP](#) to exchange the HSL/RIO I/O bridge card in the I/O unit where you just switched the cables. Then continue with the next step.
9. To determine if replacing the FRU resolved the problem, perform [Manually detecting the failed link](#) below and return to this point. Did the ports you were working on have a status of *"failed"*?
  - ◆ No: Then the problem is fixed, go to [Verifying the repair](#). This ends the procedure.
  - ◆ Yes: Continue with the next step.

- Switch the cables back to their original positions.

**Attention:** For copper cables, you must fully connect the cable and tighten the connector's screws within 30 seconds of when the cable makes contact with the port. Otherwise, the link will fail and you must disconnect and reconnect again. Also, if the connector screws are not tightened, errors will occur on the link and it will fail.

- Exchange the HSL/RIO cable between the two ports on the failed link. To determine if replacing the cable resolved the problem, perform [Manually detecting the failed link](#), then return to this point.

Did the ports you were working on have a status of *"failed"*?

- ◆ No: Then the problem is fixed, go to [Verifying the repair](#). This ends the procedure.
  - ◆ Yes: Continue with the next step.
- Use symbolic FRU [HSL\\_LNK](#) to determine if there are any additional HSL/RIO cable-related FRUs, such as interposer cards and internal ribbon cables, that may be on either unit. Did you exchange any additional HSL/RIO FRUs?
    - ◆ No: Call your next level of support for further instruction. This ends the procedure.
    - ◆ Yes: Continue with the next step.
  - To determine if replacing the FRU resolved the problem, perform [Manually detecting the failed link](#) below and return to this point. Did the ports you were working on have a status of *"failed"*?
    - ◆ No: Then the problem is fixed, go to [Verifying the repair](#). This ends the procedure.
    - ◆ Yes: Call your next level of support for further instruction. This ends the procedure.

#### Cannot power on unit

- Work the errors related to powering on the unit(s), and then continue with the next step. If a unit still cannot be powered on, re-cable the HSL/RIO loop without the I/O units and system units that cannot be powered on, allowing the loop to be complete (no disconnected cables).
- To determine if re-cabling the loop resolved the problem, perform [Manually detecting the failed link](#) below and return to this point.

#### Manually detecting the failed link

- Get the loop number from the reference code if you do not already have it. The loop number is a hexadecimal number in word 7 of the reference code.
  - ◆ If you are working from the Product Activity Log (PAL), then the loop number is the 4 leftmost characters of the DSA in word 7 (BBBB). Use the [DSA translation](#) to convert the hexadecimal loop number to decimal format before continuing with this procedure.
  - ◆ If you are working from the Service Action Log (SAL), the loop number should be displayed in the FRU description area in decimal format.
- Sign on to SST or DST (if you have not already done so). Select Start a service tool > Hardware service manager > Logical hardware resources > High-speed link (HSL) resources.
- Select Resources associated with loop for the HSL loop with the failed link. The HSL bridges will be displayed under the loop.
- Select Display detail for the loop with the failed link.
- Record the name of the NIC/RIO controller resource you are starting from on the display. You will need to know this name to determine if you have followed the loop around and back to this resource.
- If the leading port does not have a status of *"failed"*, select Follow leading port until a leading port with a *"failed"* status is found, or the display is showing information for the starting NIC/RIO resource you recorded. Did you find a leading port with a status of *"failed"*?
  - ◆ No: The loop is functioning properly. Return to the subtask that sent you here.
  - ◆ Yes: Record the resource name at the leading port with a *"failed"* status, and the type, model, and serial number for the resource with the failed status. Continue with the next step.
- Select Follow leading port one more time and note all the information for the resource name with a failed trailing port.
- Select Display system information and note the power controlling system's type, model, and serial number (and name, if available). This info may be needed for FRU replacement at a later time.
- Select Cancel twice to return to the previous screen.
- Go to each resource name (found above) and select Associated packaging resource(s). This gives the description of the failing item and the frame ID.

11. Select Display detail to find the part number and location associated with the possible failing item. Then return to the step that sent you here.

#### Refresh the port status

1. Wait one minute, and then sign on to SST or DST (if you have not already done so).
  2. Select Start a service tool > Hardware service manager > Logical hardware resources > High-speed link (HSL) resources.
  3. Move the cursor to the HSL loop that you want to examine and select Display detail > Include non-reporting resources.
  4. If the display is not already showing the ports for one of the units you are working on, then select Follow leading port. Continue to select Follow leading port until the display is showing the ports for one of the units you are working on. Note the status of the port you were working on. Select Follow leading port until the display is showing the ports for the other unit you are working on, and note the status of the port you were working on.
  5. Select Cancel > Refresh > Display detail for the failing resource you are checking. Note any change in the status for the resource. Then return to the step that sent you here.
- 

## RIOIP02

Use this procedure to determine the status of HSL/RIO ports in the loop and to identify failing resources.

1. Sign on to SST or DST (if you have not already done so).
2. Select Start a service tool > Hardware service manager > Logical hardware resources > High-speed link (HSL) resources.
3. Select Include non-reporting resources. Move the cursor to the HSL loop that you want to examine and select Display detail.
4. The display that appears shows the port status of the Network Interface Controller (NIC) for the loop that you selected. Record the resource name, type-model, and serial number, if it has not been previously recorded.
5. Is the status of the *"Leading port to next resource"* operational?
  - ◆ Yes: Select Follow Leading Port. Then continue with the next step.
  - ◆ No: You have found the first *"failed"* link. You will be directed to find the other *"failed"* link. Go to step 7.
6. Is the resource name the same name that you recorded for the NIC in step 4?
  - ◆ No: The display that appears shows the status of the HSL ports for the next I/O bridge resource on the loop. Go to step 5.
  - ◆ Yes: You have followed the HSL links around the loop and back to the NIC on the system, but did not find a failed link. Return to the procedure that sent you here. This ends the procedure.
7. Find the information for the first failing resource using the following steps:
  - a. Record the information as the *first* failing resource on the link.
  - b. Record the resource name, card type-model, and part number.
  - c. Record the link status of each port. Record 'Internal' if the port is designated as internal.
  - d. Select Cancel to return to the Work with High-speed link (HSL) resources display.
  - e. For the loop with the failure, select Resources associated with loop.
  - f. For the HSL I/O bridge with the resource name that you recorded, select Associated packaging resources.
  - g. Record the frame ID for the *first* failing link.
  - h. Select Display detail, and record the card position for the *first* failing resource.
8. Find the information for the other (second) failing resource by following these steps:
  - a. Record this information as the *second* failing resource on the link.
  - b. Select Cancel > Cancel to return to the Logical hardware associated with HSL loops display.
  - c. Move the cursor to the HSL I/O bridge with the name of the first failing resource, and select Display detail > Include non-reporting resources .
  - d. Follow the failed port by doing one of the following:
    - ◇ If the leading port is failed, select Follow leading port.
    - ◇ If the trailing port is failed, select Follow trailing port.
  - e. You have located the second failing resource on the link.
  - f. Record the resource name, card type-model, and part number.
  - g. Record the link status of each port for the second failing link. Record 'Internal' if the port is designated as internal.
  - h. Select Cancel to return to the Logical hardware associated with HSL loops display.
  - i. Select Include non-reporting resources > Associated packaging resources for the HSL I/O bridge or Network Interface Controller (NIC) with the resource name that you recorded for the

- second failed resource.
- j. Record the frame ID (if present) and port for the second failing link.
  - k. Select Display detail and record the card position for the second failing resource.
9. Have you repeated steps 1 through 8 for a second time during this procedure?
    - ◆ No: Continue with the next step.
    - ◆ Yes: Return to the procedure that sent you here. This ends the procedure.
  10. Do the *first* failing link and the *second* failing link have the same frame ID?
    - ◆ No: Continue with the next step to determine if the HSL cable connectors between the first and second failing resources are properly seated and cleaned.
    - ◆ Yes: Return to the procedure that sent you here. This ends the procedure.
  11. Disconnect the cable at the frame ID, card position, and port that you recorded for the first failing resource.
  12. Is the connection an optical link?
    - ◆ No: Wait at least 30 seconds, and then continue with the next step.
    - ◆ Yes: Clean the HSL cable connector and port using the tools and procedures listed in symbolic FRU [OPT\\_CLN](#). Then continue with the next step.
  13. Reconnect the cable to the port.

**Attention:** For copper cables you must fully connect the cable and tighten the connector's screws within 30 seconds of when the cable makes contact with the port. If you do not, the link will fail and you must disconnect and reconnect it again. If the connector screws are not tightened errors will occur on the link and it will fail.

14. Disconnect the cable at the frame ID, card position, and port that you recorded for the second failing resource.
15. Is the connection an optical link?
  - ◆ No: Wait at least 30 seconds and then continue with the next step.
  - ◆ Yes: Clean the HSL cable connector and port using the tools and procedures listed in symbolic FRU [OPT\\_CLN](#). Then continue with the next step.
16. Reconnect the cable to the port.

**Attention:** For copper cables you must fully connect the cable and tighten the connector's screws within 30 seconds of when the cable makes contact with the port. If you do not, the link will fail and you must disconnect and reconnect it again. If the connector screws are not tightened errors will occur on the link and it will fail.

17. Wait one minute to allow the changes to be detected by LIC.
18. Determine if the link has become "*operational*" by repeating steps 1 through 8 for a second time. There is no need to duplicate any information you have already recorded. Return to the procedure that sent you here, when you are directed to do so in steps 1 through 8. This ends the procedure.

## RIOIP03

Use HSM to examine the HSL Loop to find *failing* items.

Use this procedure to determine the status of HSL links in the loop.

1. Sign on to SST or DST.
2. Select Start a service tool > Hardware service manager > Logical hardware resources > High-speed link resources.
3. Move the cursor to the HSL loop that you want to examine, and select Display detail > Include non-reporting resources. The display that appears shows the port status of the HSL controller for the loop that you selected.
4. Record the resource name, type-model, and serial number, if it has not been previously recorded.
5. Is the status of the "*Leading port to next resource*" *operational*?

- ◆ Yes: Select Follow leading port. Then, continue with the next step.
  - ◆ No: You have found the first *"failed"* resource in the link. You will be directed to find the other *"failed"* resource on this link. Go to step 8.
6. Record the HSL resource name, type-model, part number, and port.
7. Is the resource name the same name that you recorded for the HSL controller in step 4?
- ◆ No: The display that appears is showing the status of the HSL ports for the next I/O adapter resource on the loop. Go to step 5.
  - ◆ Yes: You have followed the HSL links around the loop and back to the HSL controller on the system. You did not find a *"failed"* link. Return to the procedure that sent you here. This ends the procedure.
8. Find and record the information for the *"first"* failing resource using the following steps:
- a. Record the resource name, card type-model, part number, and port.
  - b. Select Cancel to return to the Work with system interconnect resources display.
  - c. Select Resources associated with ring for the loop with the failure.
  - d. Select Associated packaging resources for the HSL I/O adapter with the resource name that you recorded.
  - e. Record the frame ID, card position, and port. Record this information for the *"first"* failing link in (diagnosis form).
  - f. Select Display detail and record the card position for the *"first"* failing resource.
9. Find and record the information for the other (*second*) failing resource using the following steps:
- a. Select Cancel to return to the Logical hardware associated with HSL ring display.
  - b. For the HSL I/O adapter with the name of the *"first"* failing resource, select Display detail > Follow leading port. You have located the *"second"* failing resource on the link.
  - c. Record the resource name, card type-model, part number, port.
  - d. Select Cancel to return to the Logical hardware associated HSL rings display.
  - e. Select Associated packaging resources for the HSL I/O adapter with the resource name that you recorded for the *"second"* failed resource.
  - f. Record the frame ID, card position, and port. Record this information for the *"second"* failing link in (diagnosis form).
  - g. Select Display detail, and record the card position for the *"second"* failing resource.
10. Have you repeated steps 1 through 9 for a second time during this procedure?
- ◆ Yes: Return to the procedure that sent you here. This ends the procedure.
  - ◆ No: Does the *"first"* failing resource and the *"second"* failing resource have the same frame ID?
    - ◇ Yes: Return to the procedure that sent you here. This ends the procedure.
    - ◇ No: Perform the following to determine if the HSL cable connectors between the *first* and *second* failing resources are properly seated and clean:
      - a. Disconnect the cable at the frame ID, card position, and port that you recorded for the *"first"* failing resource, then wait 30 seconds and reconnect it.

Attention: You must fully connect the cable and tighten the connector's screws within 30 seconds of when the cable makes contact with the port. Otherwise, the link will fail and you must disconnect and reconnect the cable again. If the connector screws are not tightened, errors will occur on the link and it will fail.

      - b. Disconnect the cable at the frame ID, card position, and port that you recorded for the *"second"* failing resource, then wait 30 seconds and reconnect it. See the 30 second attention notice in step 10.a.
      - c. Refresh the port status by doing the following:
        - i. Wait 1 minute.
        - ii. Select Cancel > Refresh.

Determine if the link has become *"operational"* by repeating steps 1 through 9 for a second time, returning to the procedure that sent you here when directed.

You may see a 6982 indicating that the loop went open and then a 6985 indicating that the loop recovered. This ends the procedure.

## RIOIP04

Use HSM to examine the HSL Loop to find a failing I/O bridge resource.

1. Sign on to SST or DST.



2. Select Start a service tool > Hardware service manager > Logical hardware resources > High-speed link (HSL) resources.
3. Select Include non-reporting resources. Move the cursor to the HSL loop that you want to examine and select Display detail. The display that appears shows the port status of the Network Interface Controller (NIC) for the loop that you selected.
4. Record the resource name, type-model, and serial number, if it has not been previously recorded.
5. Is the status of the *Leading port to next resource* operational?
  - ◆ Yes: Select Follow Leading Port. Then continue with the next step.
  - ◆ No: You have found the first half of a "failing" link. Choose from the following options:
    - ◇ If this is your first time through steps 1 through 7, go to step 8.
    - ◇ If this is your second time through steps 1 through 7, go to step 9.
6. Record the HSL resource name, type-model, part number, and port.
7. Is the resource name the same name that you recorded for the NIC in step 4?
  - ◆ No: The display that appears is showing the status of the HSL ports for the next I/O bridge resource on the loop. Go to step 5.
  - ◆ Yes: You have followed the HSL links around the loop and back to the NIC on the system. You did not find a failed link. Return to the procedure that sent you here. This ends the procedure.
8. Follow the steps in [Clean and properly seat the cables](#) below.
9. Choose from the following options:
  - ◆ If the status of the *Leading port to next resource* has become "operational", the problem has been corrected. Return to the procedure that sent you here. This ends the procedure.
  - ◆ If the status is still not "operational", continue with the next step.
10. If the resource type (shown near the top of the screen, just below the bus number) is an HSL I/O bridge, then perform [Collect the resource information](#) below. Then continue with the next step.
11. Select Follow leading port to move to the resource with the failed link on the trailing port. If that resource is an HSL I/O bridge, then perform [Collect the resource information](#) below. Then return to the procedure that sent you here. This ends the procedure.

#### Collect the resource information

Find the information for the failing HSL I/O bridge using the following steps:

1. Record the resource name, card type-model, part number, and port.
2. Select Cancel to return to the Work with high-speed link (HSL) resources display.
3. Select Resources associated with loop for the loop with the failure.
4. Select Associated packaging resources for the HSL I/O bridge with the resource name that you recorded.
5. Record the frame ID.
6. Select Display detail and record the card position.
7. Go to step 11.

#### Clean and properly seat the cables

Determine if the HSL cable connectors for this HSL I/O bridge are properly seated and clean

1. Disconnect one of the cables at the frame ID/unit of the *HSL I/O bridge*.
2. Is the connection an optical link?
  - ◆ No: Wait at least 30 seconds, and then continue with the next step.
  - ◆ Yes: Clean the HSL cable connector and port using the tools and procedures listed in symbolic FRU [OPT\\_CLN](#). Then continue with the next step.
3. Reconnect the cable to the port.

**Attention:** For copper HSL/RIO cables, you must fully connect the cable and tighten the connector's screws within 30 seconds of when the cable makes contact with the port. Otherwise, the link will fail and you must disconnect and reconnect the cable again. If the connector screws are not tightened, errors will occur on the link and it will fail.

4. Disconnect the other cable at the frame ID/unit of the *HSL I/O Bridge*.
5. Is the connection an optical link?
  - ◆ No: Wait at least 30 seconds, and then continue with the next step.
  - ◆ Yes: Clean the HSL cable connector and port using the tools and procedures listed in symbolic FRU [OPT\\_CLN](#). Then continue with the next step.
6. Reconnect the cable to the port.

**Attention:** For copper HSL/RIO cables, you must fully connect the cable and tighten the connector's screws within 30 seconds of when the cable makes contact with the port. Otherwise, the link will fail and you must disconnect and reconnect the cable again. If the connector screws are not tightened, errors will occur on the link and it will fail.

7. Refresh the port status by doing the following:
  - a. Wait 1 minute.
  - b. Select Cancel > Refresh > Display detail for the failing resource.
  - c. Determine if the link has become *'operational'* by repeating steps 1 through 7 of the main procedure a second time.

## RIOIP06

Use HSM to examine the HSL Loop to determine if other systems are connected to the loop.

1. Sign on to SST or DST (if you have not already done so).
2. Select Start a service tool > Hardware service manager > Logical hardware resources > High-speed link (HSL) resources.
3. Move the cursor to the HSL loop that you want to examine, and select Resources associated with loop.
4. Search for Remote HSL NICs on the loop.

Are there any Remote HSL NICs on the loop?

- ◆ Yes: You have determined that there are other systems connected to this loop. This ends the procedure.
- ◆ No: You have determined that there are not any other systems connected to this loop. This ends the procedure.

## RIOIP07

Starting with a frame ID, for a frame connected to an HSL loop, use this procedure to determine if there is another frame with the same frame ID on the loop. This is possible when more than one system is connected to an HSL loop.

1. Sign on to SST or to DST if you have not already done so.
2. Select Start a service tool > Hardware service manager > Logical hardware resources > High-speed link (HSL) resources.
3. Move the cursor to the HSL loop that you want to examine, and select Resources associated with loop > Include non-reporting resources. The display that appears shows the loop resource and all the "HSL I/O Bridge" and all the "Remote HSL NIC" resources connected to the loop.
4. Perform the following for each HSL I/O bridge resource on the display:
  - a. Move the cursor to the HSL I/O bridge resource and select Associated packaging resource(s).
  - b. Compare the frame ID on the display with the frame ID (in hexadecimal format) that you are looking to find (Ignore leading zeros).
  - c. Are the frame IDs the same?
    - ◇ No: Select Cancel to return to the Logical Hardware Associated With HSL Loops display. Continue with the next step.
    - ◇ Yes: Perform the following steps:

- i. Record the resource name and the Type-Model of the HSL I/O Bridge with the frame ID for possible use later.
  - ii. Select Display Detail and record the "SPCN system serial number". The SPCN system serial number is the serial number of the system unit that controls the power subsystem on the frame (it connects to the frame with an SPCN cable).
  - iii. Select Cancel to return to the Packaging Resources Associated with a Logical Resource display.
  - iv. Select Cancel to return to the Logical Hardware Associated With HSL Loops display. Continue with the next step.
5. Repeat step 4 for each HSL I/O bridge under the loop. Then, continue with the next step in this procedure.
  6. Did you find more than one HSL I/O bridge with the same frame ID?
    - ◆ No: There is only one frame on the loop with the frame ID you are working with. Return to the procedure that sent you here. This ends the procedure.
    - ◆ Yes: You have recorded the resource name, the Type-Model, and the Power Controlling system of every frame on the loop that matches the frame ID that you are looking to find. This ends the procedure.
- 

## RIOIP08

Starting with the frame ID and HSL port location label for one end of an HSL cable, determine the frame ID and port location label for the other end.

1. Sign on to SST or to DST if you have not already done so.
2. Select Start a Service Tool > Hardware Service Manager > Logical Hardware Resources > High Speed Link (HSL) Resources.
3. Move the cursor to the HSL loop that you want to examine, and select Resources associated with loop > Include non-reporting resources. The display that appears shows the loop resource and all the "HSL I/O Bridge" and all the "Remote HSL NIC" resources connected to the loop.
4. Perform the following for each of the HSL I/O Bridge resources listed until you are directed to do otherwise.
  - a. Move the cursor to the HSL I/O Bridge resource and select Associated packaging resource(s).
  - b. Compare the frame ID on the display with the frame ID (in hexadecimal format) that you are looking to find (Ignore leading zeros).

Are the frame IDs the same?

  - ◇ Yes: Continue with the next step.
  - ◇ No: Select Cancel to return to the Logical Hardware Associated with HSL Loops display. Continue with the next step, repeating it for each HSL I/O Bridge under the loop, until you are directed to do otherwise.
5. Perform the following:
  - a. Select Associated logical resource(s).
  - b. Move the cursor to the HSL I/O Bridge resource and select Display detail.
  - c. Examine the *Leading port* and *Trailing port* information. Search the display for the HSL port location label that you recorded prior to starting this procedure. If the label is part of the information for the *Leading port*, then select Follow leading port. If the label is part of the information for the *Trailing port*, then select Follow trailing port.
  - d. Perform the step below that matches the function you selected in the previous step:
    - ◇ If you selected Follow leading port, then examine the display for the *Trailing port* information. Record, on the worksheet that you are using, the HSL port location label shown on the "*Trailing port from previous resource*" line. Record this information as the "*To HSL Port Label*".
    - ◇ If you selected Follow trailing port, then examine the display for the *Leading port* information. Record, on the worksheet that you are using, the HSL port location label on the "*Leading port to next resource*" line. Record this information as the "*To HSL Port Label*".
  - e. Record the "*Link type*" (Copper or Optical) on the worksheet that you are using in the field describing the cable type.
  - f. Select Cancel > Cancel > Cancel to return to the *Logical Hardware Associated With HSL Loops* display.
  - g. Record the resource name on the display.
  - h. Move the cursor to the resource with the resource name you recorded in step 5.g.

- i. Select Associated packaging resource(s).
  - j. Record the frame ID on the worksheet that you are using for the "*To Frame ID*".
  - k. Return to the procedure that sent you here. This ends the procedure.
- 

## RIOIP09

This procedure offers a description and service action for HSL reference code B600 6982.

**Note:** A fiber optic cleaning kit may be required for optical HSL connections.

**Note:** This reference code can occur on an HSL loop when an I/O expansion unit on the loop is powered off for a concurrent maintenance action.

1. Is the reference code in the Service Action Log (SAL) or serviceable event view you are using?
  - ◆ Yes: There is a connection failure on an HSL link. A B600 6984 reference code may also appear in the Product Activity Log (PAL) or error log view you are using. Both reference codes are reporting the same problem. Continue with the next step.
  - ◆ No: The reference code is only informational, and requires no service action. This ends the procedure.
2. Multiple B600 6982 errors may occur due to retry and recovery activity. Is there a B600 6985 with "xxxx 3206" in word 4 logged after all B600 6982 errors for the same HSL loop in the PAL?
  - ◆ Yes: The recovery efforts were successful. Close all of the B600 6982 entries for the same loop in the SAL. No service is required. This ends the procedure.
  - ◆ No: Continue with the next step.
3. Is there a B600 6987 reference code in the SAL, or serviceable event view you are using, logged at about the same time?
  - ◆ Yes: Close this problem and work the B600 6987. This ends the procedure.
  - ◆ No: Continue with the next step.
4. Is there a B600 6981 reference code in the SAL, or serviceable event view you are using, logged at approximately the same time?
  - ◆ Yes: Go to step 9.
  - ◆ No: Continue with the next step.
5. Perform [RIOIP06](#) to determine if this loop connects to any other systems and then return here.

**Note:** The loop number can be found in the SAL in the description for the HSL\_LNK FRU.

Is this loop connected to other systems?

- ◆ Yes: Continue with the next step.
- ◆ No: Go to step 9.

6. Check for HSL failures in the serviceable event views on the other systems. HSL failures are indicated by entries with HSL I/O bridge and Network Interface Controller (NIC) resources. Ignore B600 6982 and B600 6984 entries.

Are there HSL failures on other systems?

- ◆ Yes: Continue with the next step.
- ◆ No: Go to step 9.

7. Repair the problems on the other systems and return to this step. After making repairs on the other systems check the PAL of this system. Is there a B600 6985 reference code, with this loop's resource name, that was logged after the repairs you made on the other systems?
  - ◆ Yes: Continue with the next step.
  - ◆ No: Go to step 9.
8. For the B600 6985 reference code you found, use [SIRSTAT](#) to determine if the loop is now complete.

Is the loop complete?

- ◆ Yes: The problem has been resolved. Use [RIOIP01](#) to verify that the loop is now working properly. This ends the procedure.
  - ◆ No: Continue with the next step.
9. The FRU list displayed in the SAL, or serviceable event view you are using, may be different from the failing item list given here. Use the FRU list in the serviceable event view if it is available.

Does the reference code appear in the serviceable event view with HSL\_LNK or HSLxxxx listed as a symbolic FRU?

- ◆ Yes: Perform [RIOIP01](#). This ends the procedure.
- ◆ No: Exchange the FRUs in the serviceable event view according to their part action codes. This ends the procedure.

## RIOIP10

Use this procedure to determine if the RIO loop is complete (with both primary and redundant paths functioning for each unit on the loop).

1. Search for a B700 6985 SRC informational log (not in the serviceable event view) logged after the RIO SRC you were working on. You can find informational logs in ASMI, the AIX error log, or the Linux error log. Compare the first half of word 7 in the B700 6985 informational log to the value that caused you to be sent to this procedure. Are the two values the same?
  - ◆ No: Continue with the next step.
  - ◆ Yes: Use the informational log and [SIRSTAT](#) to determine if the loop has recovered. This ends the procedure.
2. Is this system in an RIO loop with other systems, where any of the systems on the loop is running Opticonnect?
  - ◆ No: The loop did not recover. Return to the procedure that sent you here. This ends the procedure.
  - ◆ Yes: Use the Hardware Service Manager (HSM) in to examine the RIO loop number that caused you to be sent to this procedure.
    - a. Start the HSM and display the logical resources for HSL loops.
    - b. See [DSA translation](#) and use the RIO loop numbers table to convert the hexadecimal HSL loop number to the decimal loop number. Locate the decimal loop number in the HSM display and determine the status of the loop number. Is "Operational" the status of the loop number?
      - No: The loop did not recover. Return to the procedure that sent you here. This ends the procedure.
      - Yes: The loop has recovered. This ends the procedure.

## RIOIP11

Use this procedure to recover from a B7xx 6982 high speed link (HSL) failure.

1. Record the RIO/HSL loop number in the first four characters of word 7 of this SRC and perform [RIOIP10](#).
2. Did the RIO loop recover?
  - ◆ **No:** Continue with the next step
  - ◆ **Yes:** Close the problem. **This ends the procedure.**
3. Work with the customer to determine if a system or I/O unit on the RIO loop has powered down normally.
4. Was a system or I/O unit on the loop powered down normally?
  - ◆ No: Go to 6.

- ◆ Yes: The loop remains in a failed state until all systems and I/O units on the loop are powered on and functioning. Work with the customer to determine if all the powered down systems and units on the loop can be powered on. After all system and units on the loop are powered on, continue with the next step.
5. Did the RIO loop recover?
    - ◆ No: Continue with the next step.
    - ◆ Yes: Close the problem. This ends the procedure.
  6. Search for a serviceable event with a 1xxx xxx SRC logged at approximately the same time and with one or more FRUs in the same unit as those in the FRU list for the SRC you are currently working.
  7. Did you find a serviceable event with a 1xxx xxx SRC?
    - ◆ No: Go to [9](#)
    - ◆ Yes: Work that problem. After you have repaired that error, the RIO loop may be recovered. After you complete working that problem, return to this procedure and check to determine if correcting that problem also corrected the RIO error. To determine if the RIO loop has recovered, record the RIO loop number in the first four characters of word 7 of this SRC and perform [RIOIP10](#).
  8. Did the RIO loop recover?
    - ◆ No: Continue with the next step.
    - ◆ Yes: Close the problem. This ends the procedure.
  9. Is SRC word 7 "0686 xxxx" or "0684 xxxx" and did this error occur on a Model ESCALA PL 3250R or 595?
    - ◆ **No:** Go to [13](#)
    - ◆ **Yes:** This is an internal RIO loop error. If the first FRU in the FRU list in the serviceable event view contains a part number and a location code, replace that FRU first. If not, replace Adapter 1 for Node 0 at the location given in the locations section for the system you are working on. See [Finding part locations](#) for your specific model.
  10. Did the same error reoccur?
    - ◆ **No:** Work any new errors that occur. **This ends the procedure.**
    - ◆ **Yes:** Use the Hardware Management Console to determine which service processor is the secondary service processor. Replace the secondary service processor using [SVCPROC](#). (See [Determining which Processor is the Secondary Service Processor](#) )
  11. Did the RIO loop recover?
    - ◆ **No:** Replace the backplane of node 0 using [NODEPL](#).
    - ◆ **Yes:** Close the problem. **This ends the procedure.**
  12. Did the same error reoccur?
    - ◆ **No:** Work any new errors that occur. **This ends the procedure.**
    - ◆ **Yes:** Replace the system backplane using [Removing and replacing parts](#). **This ends the procedure.**
  13. In the serviceable event view, search for a B700 6981 error logged at approximately the same time and on the same RIO loop (the first four characters of word 7 are the same).
  14. Did you find a serviceable event with a B700 6981 SRC at approximately the same time and on the same RIO loop?
    - ◆ No: Go to [16](#).
    - ◆ Yes: Work that problem. After you have repaired that error, the RIO loop may be recovered. After you complete working that problem, return to this procedure and check to determine if correcting that problem also corrected the HSL/RIO error. To determine if the RIO loop has recovered, record the RIO loop number in the first four characters of word 7 of this SRC and perform [RIOIP10](#).
  15. Did the RIO loop recover?
    - ◆ No: Continue with the next step.
    - ◆ Yes: Close the problem. This ends the procedure.
  16. Using the FRU list that you are working with for this SRC, exchange one FRU at a time. After you exchange each FRU, determine if the loop has recovered. To determine if the RIO loop has recovered, record the RIO loop number in the first four characters of word 7 of this SRC and perform [RIOIP10](#). After the loop recovers or after you have exchanged all the FRUs, continue with the next step.
  17. Did the RIO loop recover?
    - ◆ No: Contact your next level of support. This ends the procedure.
    - ◆ Yes: Close the problem. This ends the procedure.
- 

## RIOIP12

Use this procedure to recover from a B7xx 6985 high speed link (HSL) failure.

1. Work with the customer to determine if a system or I/O unit on the RIO loop has powered down normally.
2. Was a system or I/O unit on the loop powered down normally?
  - ◆ No: Go to [4](#).
  - ◆ Yes: The loop remains in a failed state until all systems and I/O units on the loop are powered on and functioning. Work with the customer to determine if all the powered down systems and units on the loop can be powered on. After all system and units on the loop are powered on, check to determine if the RIO loop is complete. To determine if the RIO loop has recovered, record the RIO loop number in the first four characters of word 7 of this SRC and perform [RIOIP10](#).
3. Did the RIO loop recover?
  - ◆ No: Continue with the next step.
  - ◆ Yes: Close the problem. This ends the procedure.
4. In the serviceable event view, search for a B700 6981 or a B700 6986 error logged at approximately the same time and on the same RIO loop (the first four characters of word 7 are the same).
5. Did you find a serviceable event with a 1xxx xxxx SRC?
  - ◆ No: Go to [7](#)
  - ◆ Yes: Work that problem. After you have repaired that error, the RIO loop may be recovered. After you complete working that problem, return to this procedure and check to determine if correcting that problem also corrected the RIO error. To determine if the HSL/RIO loop has recovered, record the RIO loop number in the first four characters of word 7 of this SRC and perform [RIOIP10](#).
6. Did the RIO loop recover?
  - ◆ No: Continue with the next step.
  - ◆ Yes: Close the problem. This ends the procedure.
7. In the serviceable event view, search for a B700 6981 or B700 6986 error logged at approximately the same time and on the same RIO loop (the first four characters of word 7 are the same).
8. Did you find a B700 6981 or a B700 6986 error logged at approximately the same time and on the same RIO loop?
  - ◆ No: Go to [10](#).
  - ◆ Yes: Work that problem. After you have repaired that error, the RIO loop may be recovered. After you complete working that problem, return to this procedure and check to determine if correcting that problem also corrected the RIO error. To determine if the RIO loop has recovered, record the RIO loop number in the first four characters of word 7 of this SRC and perform [RIOIP10](#).
9. Did the RIO loop recover?
  - ◆ No: Continue with the next step.
  - ◆ Yes: Close the problem. This ends the procedure.
10. Search for a system or IO unit on the RIO loop that has not powered up as expected.
11. Did you find a system or IO unit on the RIO loop that has not powered up as expected?
  - ◆ No: Go to [13](#).
  - ◆ Yes: Go to [Cannot power on SPCN-controlled I/O expansion unit](#) and work that power symptom. Use the first half of word 7 to determine the loop number for later use. After you have repaired that error, the RIO loop may be recovered. After you complete working that power symptom, return to this procedure and check to determine if correcting that problem also corrected the RIO error. To determine if the RIO loop has recovered, record the RIO loop number in the first four characters of word 7 of this SRC and perform [RIOIP10](#).
12. Did the RIO loop recover?
  - ◆ No: Continue with the next step.
  - ◆ Yes: Close the problem. This ends the procedure.
13. Using the FRU list that you are working with for this SRC, exchange one FRU at a time. After you exchange each FRU, determine if the loop has recovered. To determine if the RIO loop has recovered, record the RIO loop number in the first four characters of word 7 of this SRC and perform [RIOIP10](#). After the loop recovers or after you have exchanged all the FRUs, continue with the next step.
14. Did the RIO loop recover?
  - ◆ No: Contact your next level of support. This ends the procedure.
  - ◆ Yes: Close the problem. This ends the procedure.

---

## RIOIP50

If the system you are working on has an HMC, service this error using the HMC's interfaces.

This procedure will help you isolate failing items for HSL/RIO link errors. The basic FRU list for such errors is one RIO hub (NIC, bridge, or remote NIC), a cable, and the RIO hub on the other end of the cable. There are two initial conditions. Choose the scenario you are dealing with:

- You are working the problem from service documentation or from a Service Action Log (SAL) entry without complete part number and location information for each RIO hub. Start with the [Preliminary task](#) to determine which segment of the HSL/RIO loop has failed.
- You are working this problem from the SAL with complete part number and location information for each RIO hub. Perform [RIOIP01](#).

#### Preliminary task

Perform the following to determine which segment of the HSL/RIO loop has failed:

1. Get the loop number from the reference code if you do not already have it. The hexadecimal loop number is the 4 leftmost characters of the DSA in word 7 of the reference code. Before continuing to the next step, use [DSA translation](#) to find the loop number and translate it into decimal format.
2. Sign on to SST or DST (if you have not already done so). Select Start a service tool > Hardware service manager > Logical hardware resources > High-speed link (HSL) resources.
3. Select Resources associated with loop for the loop with the failed link. The HSL bridges will be displayed under the loop.
4. Select Display detail for the loop with the failed link.
5. Select Follow leading port until a port with a status of "failed" is found. Note the resource name, type-model, and serial number for the resource with the failed status.
6. Select Follow leading port one more time and note all the information for the resource name with a failed trailing port.
7. Select Display system information and note the power controlling system. This information may be needed for concurrent replacement at a later time.
8. Select Cancel twice to return to the previous screen.
9. Go to each resource name (found above) and select Associated packaging resource(s). This gives the description of the failing item and the frame ID.
10. Select Display detail to find the part number and location associated with the possible failing item.
11. Now you have the same information you would have if the SAL had complete part number and location information. Perform [RIOIP01](#).

---

## RIOIP55

There is an open RIO loop at IPL time.

The system may have tried multiple times to establish a complete RIO loop. This could result in multiple permanent B700 6985 errors for the same RIO loop. Check the following:

1. Look in the informational logs for a B700 6985 occurring on the same RIO loop with a value of xxxx 3206 or xxxx 3208 in word 4. These indicate a retry attempt was successful and the permanent B700 6985 errors for that loop can be closed with no further action necessary.
2. If there is a clustered system on the RIO loop that had not finished its IPL at the time of the error, you should check for a similar error on that system. These errors will occur until all systems on the loop have been completed their IPL. If there is a similar error on the last system to complete its IPL, work the error from that system. Otherwise you can close this error.
3. Check cable seating for the cable indicated in the locations given in the serviceable event view. If no locations are given, check the RIO Loop Status in the view on the operating system or on the HMC. Find the failed link and check cable connections there. If the cable is an optical cable, use [OPT\\_CLN](#) for direction on cleaning the optical connections.



- If the error persists after steps 1 and 2 above, continue working the error with the FRUs given in the serviceable event view or service documentation. This ends the procedure.
- 

## MABIP05

Use this procedure to reset an IOP.

**Attention:** When the IOP reset is performed, all resources controlled by the IOP will be reset. Perform this procedure only if the customer has verified that the IOP reset can be performed at this time.

- Go to the SST/DST display in the partition which reported the problem. Use STRSST if is running; use function 21 if STRSST does not work; or IPL the partition to DST.
  - On the Start Service Tools Sign On display, type in a user ID with service authority and password.
  - Select Start a service tool > Hardware service manager > Logical hardware resources > System bus resources.
  - Page forward until you find the IOP that you want to reset. For help in identifying the IOP from the Direct Select Address (DSA) in the reference code, see [DSA translation](#).
  - Verify that the IOP are correct by matching the resource name(s) on the display with the resource name(s) in the Service Action Log (SAL) for the problem you are working on.
  - Move the cursor to the IOP that you want to reset, and select I/O Debug > Reset IOP > IPL IOP. This ends the procedure.
- 

## MABIP06

Use this procedure to isolate a failing I/O adapter under an IOP.

The procedure will iterate through each IOA under the IOP, powering each one off, and then resetting the IOP. This process will be repeated until the failing IOA is isolated.

- If the system is not IPLed, will it IPL to DST?
  - ◆ No: Perform [MABIP07](#). This ends the procedure.
  - ◆ Yes: From the SAL display for the SRC, record the count. Continue with the next step.
- Go to the SST/DST display in the partition which reported the problem:
  - ◆ If is running, use STRSST.
  - ◆ If STRSST does not work, use function 21.
  - ◆ Or IPL the partition to DST.
 Continue with the next step.
- On the Start Service Tools Sign On display, type in a user ID with service authority and password.
- Select Start a service tool > Hardware service manager > Logical hardware resources > System bus resources.
- Is there a resource name logged in the SAL entry?
  - ◆ No: Continue with the next step.
  - ◆ Yes: Go to step 11.
- Do you have a location for the I/O processor?
  - ◆ No: Record the Direct Select Address (DSA) of the SRC (word 7) from the SAL display (see [DSA translation](#)). Then continue with the next step.
  - ◆ Yes: Go to step 9.
- Return to the HSM System bus resources display. Locate the I/O processor by performing the following:
  - Select Display detail.
  - Compare the DSA from word 7 with the bus, card, and board information for the IOP.

**Note:** The card information on the HSM display is in decimal format. You must convert the decimal card information in to hexadecimal format to match the DSA format.

| Decimal format | Hexadecimal format |
|----------------|--------------------|
| 16             | 10                 |
| 17             | 11                 |
| 18             | 12                 |
| 19             | 13                 |
| 20             | 14                 |
| 21             | 15                 |
| 22             | 16                 |
| 23             | 17                 |
| 32             | 20                 |
| 33             | 21                 |
| 34             | 22                 |
| 35             | 23                 |
| 36             | 24                 |
| 37             | 25                 |
| 38             | 26                 |
| 39             | 27                 |

- c. Repeat this step until you find the IOP with the same DSA. Then continue with the next step.
8. Select Cancel, and then go to step 12.
9. Locate the I/O processor in HSM by performing the following for each IOP:
  - a. Select Associated packaging resource(s) > Display detail.
  - b. Repeat until you find the IOP with the same location. Then continue with the next step.
10. Select Cancel > Cancel and go to step 12.
11. Page forward until you find the multi-adapter bridge and IOP where the problem exists. Verify that the multi-adapter bridge and IOP are correct by matching the resource name(s) on the display with the resource name(s) in the SAL for the problem that you are working on.
12. For the IOP that you are working on, select Resources associated with IOP (if the I/O adapters are not already displayed), and then Include non-reporting resources.
13. If there is an IOA that is listed in any state other than *operational*, then perform steps 14 through 17, starting with the disabled IOA by moving the cursor to the disabled IOA. Otherwise, move the cursor to the first IOA that is assigned to the IOP.
14. Select Associated packaging resource(s) > Concurrent maintenance > Power off domain. Record the Frame ID and Location of the slot you are powering off. Did the domain power off successfully?
  - ◆ Yes: Perform MABIP05, and then return here and continue with the next step.
  - ◆ No: Choose from the following options:
    - ◇ If only one IOA was listed as failing, power down the system and replace the IOA. Re-IPL the system. If a different SRC occurs, go to [Start of call procedure](#) and service that SRC. If there was no SRC, go to [Verifying the repair](#). This ends the procedure.
    - ◇ If there were multiple failed IOAs and concurrent maintenance did not work on one, then move to the next failed IOA and repeat steps 14 through 17.
    - ◇ If concurrent maintenance does not work for multiple failed IOAs, this procedure will not be able to identify a failing I/O adapter. Return to the procedure that sent you here. This ends the procedure.
15. Did the IOP reset and IPL successfully?
  - ◆ No: You will not be able to identify a *failing* I/O adapter with this procedure. Return to the procedure that sent you here. This ends the procedure.
  - ◆ Yes: Check for the same failure that sent you to this procedure. Check the system control panel, the SAL for the partition that reported the problem, or the Work with partition status display for the partition that reported the problem. In the SAL, the count will increase if the

- SRC occurred again. Continue with the next step.
16. Did the same SRC occur after the IOP was reset and IPL'd?
    - ◆ No: Go to step [18](#).
    - ◆ Yes: Perform the following steps:
      - a. Go to the Hardware Service Manager display.
      - b. Go to Packaging Hardware Resources.
      - c. Power on the IOA by selecting Power on domain.
      - d. Reassign the IOA to the IOP.
      - e. Return to the HSL resource display, showing the IOP and associated resources.
      - f. Continue with the next step.
  17. Is there any other IOA, assigned to the IOP, that you have not already powered off and on?
    - ◆ No: Go to step [20](#).
    - ◆ Yes: Move the cursor to another IOA assigned to the IOP, choosing IOAs with a status of *unknown* or *disabled* before moving on to IOAs with a status of *operational*. Go to step [14](#).
  18. You have located the failing IOA. Exchange the I/O adapter that you just powered off. Use the location you recorded in step 14 to locate the IOA.
  19. Power on the IOA that you just exchanged. Does the same SRC that sent you to this procedure still occur?
    - ◆ Yes: The IOA is not the failing item. Remove the IOA and reinstall the original IOA. Continue with the next step.
    - ◆ No: You have exchanged the failing IOA. Go to [Verifying a high-speed link, system PCI bus, or a multi-adapter bridge repair](#). This ends the procedure.
  20. No failing IOAs were identified. Return to the procedure that sent you here. This ends the procedure.
- 

## MABIP07

Use this procedure to isolate a failing PCI I/O adapter card from an SRC.

**Attention:** The removal and replacement of all FRUs in this procedure must be performed using dedicated maintenance.

1. Determine the "PCI bridge set" (multi-adapter bridge domain) by performing the following:
  - a. Record the bus number (BBBB), the multi-adapter bridge number (C) and the multi-adapter bridge function number (c) from the Direct Select Address (DSA). See [Breaking down a RIO/HSL or PCI bus reference code](#) for help in determining these values.
  - b. Use the bus number that you recorded and the "System Configuration Listing" or ask the customer to determine what frame the bus is in.
  - c. Record the frame type where the bus is located.
  - d. The PCI bridge set is the group of card positions controlled by the same multi-adapter bridge on the bus that you recorded. Use the "System Configuration Listing", the card position table for the frame type that you recorded, the bus number, and the multi-adapter bridge number to determine the PCI bridge set where the failure occurred. Refer to the [Card positions](#) to locate the card position table for the frame type that you recorded.
  - e. Print out the [Installed features in a PCI bridge set form](#).
  - f. Using the card position table, record the PCI bridge set card positions, and multi-adapter bridge function numbers on the form.
  - g. Examine the PCI bridge set in the frame and record the information on the form for all of the positions with IOP and IOA cards installed in them.
  - h. The IOP with a failing IOA is in the card position that matches the multi-adapter bridge function number that you recorded in the DSA. In the "IOP" or "IOA" column of the form, write the word "DSA" next to the IOP that is identified in the DSA.
  - i. Using the form, start at the card position for the IOP in the DSA and search down the "IOP" or "IOA" column (increasing multi-adapter bridge function numbers) and mark each IOA with an "X" until you hit the next IOP or the bottom of the column. The IOAs that you marked with "X" are all under the control of the IOP that is indicated in the DSA.
2. Did the SRC appear on the system control panel or the system console?
  - ◆ No: Continue with the next step.

- ◆ Yes: This procedure will instruct you to power off and power on the system or partition with the problem. Perform that function as you would normally power off and power on the system. Continue with step 4.
3. When this procedure instructs you to power on the system or partition, power off or power on only the partition that reported the problem by selecting Work with system partitions under SST/DST. Then, from the Primary partition, use HSM concurrent maintenance to power off the card positions that you are instructed to work with. The remove and replace procedures for those positions will guide you through the HSM concurrent maintenance functions. Use this procedure to find the correct remove and replace procedure for each card position that you are instructed to work with.
  4. Power off the system or partition.
  5. Remove all of the IOAs that you marked with an "X" in Installed features in a PCI bridge set form. Be sure to record the card position of each IOA so that you can reinstall it in the same position later. To determine the remove and replace procedures for the IOAs, locate the IOA card positions in the FRU locations and failing items table for the frame type that you recorded. See [Finding part locations](#) for details.
  6. Power on the system or partition.

Does the SRC or failure that sent you to this procedure occur?

- ◆ Yes: Continue with the next step.
  - ◆ No: Power off the system or partition. Go to step 12.
7. Perform the following steps:
    - a. Power off the system or partition.
    - b. Exchange the IOP that is indicated in the DSA. Be sure to record the card position of the IOPs so that you can reinstall it in the same position later. To determine the remove and replace procedure for the IOP, locate the IOP's card position in the FRU locations and failing items table for the frame type you recorded. Refer to [Finding part locations](#) for details.
    - c. Power on the system or partition.

Does the SRC or failure that sent you to this procedure occur?

- ◇ No: Power off the system or partition and continue with the next step.
  - ◇ Yes: Go to step 18.
8. Install all of the IOAs that you removed in step 5. Be sure to install them in their original positions.
  9. Power on the system or partition.

Does the SRC or failure that sent you to this procedure occur?

- ◆ Yes: Power off the system or partition. Then, continue with the next step.
  - ◆ No: Perform [Verifying a high-speed link, system PCI bus, or a multi-adapter bridge repair](#). This ends the procedure.
10. Remove all of the IOAs that you marked with an "X" in Installed features in a PCI bridge set form. Be sure to record the card position of each IOA so that you can reinstall it in the same position later.
  11. Remove the IOP that you exchanged and install the original IOP in its original position.
  12. Reinstall, in its original position, one of the IOA adapters that you removed.
  13. Power on the system or partition.

Does the SRC or failure that sent you to this procedure occur?

- ◆ Yes: The I/O adapter card that you just installed is the failing FRU. Continue with the next step.
- ◆ No: Power off the system or partition. Repeat step 12 for another one of the I/O adapter cards that you removed.

If you have reconnected all of the I/O adapters and the SRC or failure that sent you to this procedure does not occur, the problem is intermittent. This ends the procedure.

14. Power off the system or partition.
15. Exchange the I/O adapter card that you last installed. Be sure to install the new I/O adapter card in the same position.
16. Power on the system or partition.

Does the SRC or failure that sent you to this procedure occur?

- ◆ No: Power off the system or partition. Then, continue with the next step.
  - ◆ Yes: Call your next level of support. This ends the procedure.
17. Reinstall, in their original positions, the remaining I/O adapter cards that you removed.

Does the SRC or failure that sent you to this procedure occur?

- ◆ Yes: Call your next level of support. This ends the procedure.
  - ◆ No: Does a different SRC occur?
    - ◇ Yes: Go to [Start of call procedure](#) and follow the service procedures for the new SRC. This ends the procedure.
    - ◇ No: Perform [Verifying a high-speed link, system PCI bus, or a multi-adapter bridge repair](#). This ends the procedure.
18. The problem is the multi-adapter bridge. Power off the system or partition.
  19. Determine which FRU contains the multi-adapter bridge which controls the IOP in the DSA by performing the following:
    - a. Locate the card position table for the frame type that you recorded. Refer to the [Card positions](#) to locate the card position table for the frame type that you recorded.
    - b. Using the multi-adapter bridge number that you recorded, search for the multi-adapter bridge function number "F" in the card position table to determine the card position of the multi-adapter bridge's FRU.
  20. Is the multi-adapter bridge's FRU, a FRU that you have already exchanged?
    - ◆ No: Remove the IOP that you exchanged. You will be reinstalling the original IOP later in this procedure. Then, continue with the next step.
    - ◆ Yes: Call your next level of support. This ends the procedure.
  21. Exchange the card multi-adapter bridge's FRU at the card position that you determined for it. To determine the remove and replace procedure for the multi-adapter bridge's FRU, locate the FRU's card position in the FRU locations and failing items table for the frame type that you recorded. FRU locations and failing items tables are in [Finding part locations](#).
  22. Install the original IOP in its original position.
  23. Install all of the other IOPs and IOAs in to their original positions. Do not install the IOAs that you were instructed to remove in step 5.
  24. Power on the system or partition.

Does the SRC or failure that sent you to this procedure occur?

- ◆ No: Install all of the IOAs that you removed in step 5. Be sure to install them in their original positions. Then, continue with the next step.
  - ◆ Yes: Call your next level of support. This ends the procedure.
25. Power on the system or partition.

Does the SRC or failure that sent you to this procedure occur?

- ◆ No: This ends the procedure.
- ◆ Yes: Call your next level of support. This ends the procedure.

## MABIP50

Use this procedure to isolate a failing PCI card (either an IOA or IOP) under a multi-adapter bridge.

**Attention:** This procedure is for use with only. Go to [PCI bus isolation using AIX, Linux, or the HMC](#) to isolate a PCI bus problem from AIX, Linux, or the HMC.

This procedure iterates through any IOPs under the multi-adapter bridge and any PCI cards operating without an IOP. It powers off each one, and then resets the multi-adapter bridge. This process repeats until it isolates the failing part.

1. Does the partition IPL to DST?
  - ◆ Yes: Go to the SST/DST display in the partition that reported the problem. If is running, use STRSST; if STRSST does not work, use function 21. If is not running, IPL the partition to DST. Then, continue with the next step.
  - ◆ No: Perform [MABIP52](#). This ends the procedure.

2. On the Start Service Tools Sign On display, type in a user ID with QSRV authority and password.
3. Select Start a service tool > Hardware service manager > Logical hardware resources > System bus resources.
4. Page forward until you find the multi-adapter bridge where the problem was reported. For help in identifying the multi-adapter bridge from the Direct Select Address (DSA) in the reference code, see [DSA translation](#). Verify that the multi-adapter bridge is the correct one by matching the resource name on the display with the resource name in the Service Action Log (SAL) for the problem that you are working on.
5. Select Include non-reporting resources.
6. Move the cursor to the first IOP under the multi-adapter bridge.
7. For each IOP that is under the multi-adapter bridge that you are working on, select Associated packaging resource(s) > Display detail.
8. Record the location of the IOP, except for virtual IOPs.
9. Select Cancel > Cancel.
10. Select Resources associated with IOP.
11. For each I/O adapter under the IOP, perform the following:
  - a. Select Associated packaging resource(s) > Display detail.
  - b. Record the location.

**Note:** There will be one IOA resource under each virtual IOP.

12. Perform the following:
  - a. Power off the frame or tower (see [Powering on and powering off](#)).
  - b. Remove one of the IOPs and all of its IOAs, or the one IOA resource under a virtual IOP.
  - c. Power on the frame or tower (see [Powering on and powering off](#)). Continue with the next step.
13. Check for the same failure that brought you to this procedure. Check the system control panel, the SAL for the partition that reported the problem, or the Work with partition status display for the partition that reported the problem.

Did the same reference code appear?

- ◆ Yes: Power on the frame or tower. Then continue with the next step.
  - ◆ No: Go to step [15](#).
14. Return to the System bus resources display showing the multi-adapter bridge and the associated resources. Is there another IOP under the multi-adapter bridge?
    - ◆ No: Go to step [17](#).
    - ◆ Yes: Return to step [12](#).
  15. The failing item is either the IOP or one of the I/O adapters that it controls. Reinstall the IOP and I/O adapters that you just removed. Perform [MABIP55](#). If this procedure does not help you to identify a failing I/O adapter, then return here and continue with the next step in this procedure.
  16. Perform the following:
    - a. Exchange the IOP that you identified in step [15](#).
    - b. Power on the frame or tower.

Does the same reference code that sent you to this procedure occur?

- ◆ No: The failing item was the IOP that you just exchanged. Reinstall all of the other IOPs and I/O adapters that you removed during this procedure. Go to [Verifying the repair](#). This ends the procedure.
  - ◆ Yes: Continue with the next step.
17. The failing item is the FRU containing the multi-adapter bridge which controls this IOP, or an IOA that is not under an IOP. Perform the following:
    - a. Power off the unit that you are working on.
    - b. Exchange the FRU containing the multi-adapter bridge using symbolic FRU [MA\\_BRDG](#).
    - c. Power on the unit that you are working on.
- Does the same reference code that sent you to this procedure occur?
- ◆ No: The failing item was the multi-adapter bridge FRU that you just exchanged. Reinstall all of the other IOPs and I/O adapters that you removed during this procedure. Go to [Verifying the repair](#). This ends the procedure.
  - ◆ Yes: Contact your next level of support. This ends the procedure.

## MABIP51

Use this procedure to resolve a problem with a multi-adapter bridge.

**Attention:** This procedure is for use with only. Go to [PCI bus isolation using AIX, Linux, or the HMC](#) to isolate a PCI bus problem from AIX, Linux, or the HMC.

This procedure will determine if the multi-adapter bridge is failing when the symbolic FRU PIOCARD is in the failing item list. It will also determine if the symbolic FRU PIOCARD can be removed from the FRU list.

Use the Service Action Log (SAL) to check for other errors under the same multi-adapter bridge using the following steps:

1. Were you able to obtain a location for the PIOCARD FRU from the SAL?
  - ◆ No: Find the reference code in the SAL and record the Direct Select Address (DSA), which is in word 7 (see [DSA translation](#)). Then, continue with the next step.
  - ◆ Yes: Go to step 5.
2. Record the bus number (BBBB) and the multi-adapter bridge number (C) of the DSA (see [DSA translation](#)).
3. Go to [MABIP53](#) to determine the location of the PCI I/O card in the failing item list. Then return here and continue with the next step.
4. Using the [card position table](#) for the frame or I/O tower type that you recorded in [MABIP53](#), determine which of the card positions within the frame or I/O tower are controlled by the same multi-adapter bridge that is controlling the PCI I/O card for which you determined the location in step 3. A card position is controlled by the same multi-adapter bridge if it has the same bus number and multi-adapter bridge number as the PCI I/O Card that you located in step 3. Record the card position and the DSA from the card position table for each card position that is controlled by the same multi-adapter bridge.
5. Look in the SAL (see [Using the Service Action Log](#)) for other failures in the same frame that are either located in any of the card positions that you recorded in step 4 or are listed with the PIOCARD FRU.

Are any such failures listed in the SAL?

- ◆ No: Use the failing item list that you were using when you started this procedure. This ends the procedure.
- ◆ Yes: The multi-adapter bridge is failing. Remove symbolic FRU PIOCARD from the list of failing items, as it is not the failing FRU. This ends the procedure.

## MABIP52

This procedure will isolate a failing PCI card from a reference code when the system or logical partition will not IPL.

**Attention:** The remove and replace procedure of all FRUs in this procedure must be performed using "Dedicated Maintenance".

1. Determine the PCI bridge set (multi-adapter bridge domain) by performing the following:
  - a. Record the bus number (BBBB), the multi-adapter bridge number (C) and the multi-adapter bridge function number (c) from the Direct Select Address (DSA) in word 7 of the reference

code in the SAL entry. See [DSA translation](#) for help in determining these values.

- b. Use the bus number that you recorded and the System Configuration Listing (or ask the customer) to determine what frame the bus is in.
  - c. Record the frame type where the bus is located.
  - d. The PCI bridge set is the group of card positions controlled by the same multi-adapter bridge on the bus that you recorded. Use the System Configuration Listing, the [card position table](#) for the frame type that you recorded, the bus number, and the multi-adapter bridge number to determine the PCI bridge set where the failure occurred.
  - e. Print out the [Installed features in a PCI bridge set form](#) form to use in the following steps.
  - f. Using the [card position table](#), write the PCI bridge set card positions and multi-adapter bridge function numbers into the form.
  - g. Examine the PCI bridge set in the frame, and record the information in the form for all of the positions with IOP and IOA cards installed in them.
  - h. In the form, start at the top row and search down the "IOP" or "IOA" column (increasing multi-adapter bridge function numbers) and mark each IOP with an "X" until you hit the bottom of the column. The IOPs that you marked with "X" are all under the control of the multi-adapter bridge indicated in the DSA.
2. Did the reference code appear on the system control panel or the system console (this would happen if the system does not have multiple partitions or if the failure occurred in the Primary partition of a system with multiple partitions)?
- ◆ No: When this procedure instructs you to power off and power on the system or partition, power off or power on only the partition that reported the problem by selecting Work with system partitions under SST/DST. Then, from the Primary partition, use HSM concurrent maintenance to power off the card positions that you are instructed to work with. The remove and replace procedures for those positions will guide you through the HSM concurrent maintenance functions. This procedure will guide you to the correct remove and replace procedure for each card position that you are instructed to work with. Continue with the next step.
  - ◆ Yes: This procedure instructs you to power off and power on the system or partition with the problem. Perform that function as you would normally power off and power on the system. Continue with the next step.
3. Perform the following:
- a. Power off the system or partition.
  - b. Remove all the IOPs you marked with an "X" and all the IOAs on the form. Be sure to record the card position of each IOP and IOA so that you can reinstall it in the same position later. To determine the remove and replace procedures for the IOPs and IOAs, go to [Finding part locations](#).
  - c. Power on the system or partition.

Does the reference code or failure that sent you to this procedure occur?

◇ No: Continue with the next step.

◇ Yes: The problem is the multi-adapter bridge. Continue with step 9.

4. Starting at the empty card position with the lowest multi-adapter bridge function number from the form, reinstall (in their original positions) one of the IOPs and all of the IOAs between it and the next IOP.
5. Power on the system or partition. Does the reference code or failure that sent you to this procedure occur?
- ◆ Yes: The I/O processor card that you just installed is the failing FRU. Continue with the next step.
  - ◆ No: Power off the system or partition. Repeat step 4 for another one of the I/O processor cards that you removed. If you have reconnected all of the IOPs and the reference code or failure that sent you to this procedure does not occur, the problem is intermittent; contact your next level of support. This ends the procedure.
6. Perform the following:
- a. Power off the system or partition.
  - b. Exchange the I/O processor card you last installed. Be sure to install the new I/O processor card in the same position.
  - c. Power on the system or partition.

Does the reference code or failure that sent you to this procedure occur?

◆ No: Power off the system or partition. Then, continue with the next step.

◆ Yes: Remove the IOP that you just installed and reinstall the original IOP in its original position. Then perform [MABIP54](#). This ends the procedure.

7. Reinstall, in their original positions, the remaining IOP and IOA cards that you removed.

Does the reference code or failure that sent you to this procedure occur?



- ◆ Yes: Call your next level of support. This ends the procedure.
  - ◆ No: Continue with the next step.
8. Does a different reference code occur?
- ◆ Yes: Return to [Start of call procedure](#) and follow the service procedures for the new reference code. This ends the procedure.
  - ◆ No: Go to [Verifying the repair](#). This ends the procedure.
9. Power off the system or partition.
10. Determine which FRU contains the multi-adapter bridge that controls the IOP in the DSA by performing the following:
- a. Locate the [card position table](#) for the frame type that you recorded.
  - b. Using the multi-adapter bridge number that you recorded, search for the multi-adapter bridge function number "F" in the card position table to determine the card position of the multi-adapter bridge's FRU.
- Is the multi-adapter bridge's FRU a FRU that you have already exchanged?
- ◆ No: Remove the IOP that you exchanged. You will be reinstalling the original IOP later in this procedure. Then, continue with the next step.
  - ◆ Yes: Call you next level of support. This ends the procedure.
11. Perform the following:
- a. Exchange the multi-adapter bridge's FRU at the card position that you determined for it. See [Finding part locations](#) to determine the correct remove and replace procedure.
  - b. Install all IOPs and IOAs in their original positions.
  - c. Power on the system or partition.
- Does the reference code or failure that sent you to this procedure occur?
- ◆ No: Go to [Verifying the repair](#). This ends the procedure.
  - ◆ Yes: Call your next level of support. This ends the procedure.

## MABIP53

Use this procedure to determine a card position when no location is given for a PCI adapter FRU.

**Attention:** This procedure is for use with and B7xx reference codes only. Go to [PCI bus isolation using AIX, Linux, or the HMC](#) to isolate a PCI bus problem from AIX, Linux, or the HMC.

This procedure uses the Direct Select Address given in the reference code because no location was given for a PCI adapter FRU.

1. If you were sent to this procedure with a specific Direct Select Address (DSA), then use it. Otherwise, use the DSA in the reference code. Refer to [DSA translation](#) to find the DSA in the reference code and translate it into the `BBBB Cc` values that you use in later steps of this procedure.
2. Perform the following:
  - a. Record the bus number value, `BBBB`, in the DSA and convert it to decimal format.
  - b. Search for the decimal bus number in HSM or the System Configuration Listing to determine which frame or I/O unit contains the failing item. From the HSM screen select Logical Hardware Resources > System Bus resources. Move the cursor to a system bus object and select Display Detail. Do this for each bus until you find the bus on which you are working.
  - c. Record the frame or unit type.
3. Record the `Cc` value in the DSA. Is the `Cc` value greater than 00?
  - ◆ No: The multi-adapter bridge and the multi-adapter function number are not identified. Record that the multi-adapter bridge is not identified in the DSA. The card slot cannot be identified using the DSA. Go to step 8.
  - ◆ Yes: Continue with the next step.
4. Is the right-most character of the `Cc` value 'F'?
  - ◆ No: Continue with the next step.
  - ◆ Yes: Only the multi-adapter bridge number is identified. Record the multi-adapter bridge number (the leftmost character of the `Cc` value) for later use. The card slot cannot be

identified using the DSA. Go to step 8.

5. Are you working with a B7xx reference code?
  - ◆ No: Go to step 7.
  - ◆ Yes: Continue with the next step.
6. Is SST/DST available?
  - ◆ No: Continue with the next step.
  - ◆ Yes: Go to step 12.
7. Use the [card position tables](#) with the BBBB and CC values that you recorded to identify the card position. Then return to the procedure, failing item, or symbolic FRU that sent you here. This ends the procedure.
8. Perform the following:
  - a. Sign onto SST or DST if you have not already done so.
  - b. Select Start a service tool > Hardware service manager > Logical Hardware Resources > System bus resources.
  - c. Put the bus number in the System bus(es) to work with field. Then select Include non-reporting resources and examine the display.

Is there more than one multi-adapter bridge connected to the bus resource you are working with?

- ◆ Yes: Continue with the next step.
- ◆ No: Go to step 11.

9. Was there a multi-adapter bridge number identified in the CC value of the DSA?
  - ◆ Yes: Continue with the next step.
  - ◆ No: From the Logical Hardware Resources on System Bus display, examine the status of all the resources under the bus, looking for a "failed" resource.
    - ◇ To examine the status of the IOAs, select Resources associated with IOP for each IOP under the bus.
    - ◇ To determine the card position of a failed resource, select Associated packaging resource(s) > Display detail and record the frame ID, card position, and part number.

Return to the procedure that sent you here. This ends the procedure.
10. Search for the multi-adapter bridge number that is identified in the DSA by moving the cursor to each multi-adapter bridge resource and selecting Display detail. Convert the system card value to hexadecimal (it is displayed in decimal format). The hexadecimal system card value is the CC address of the multi-adapter bridge. When you find the multi-adapter bridge resource, where the multi-adapter bridge number (the leftmost character of the hexadecimal CC value) matches the multi-adapter bridge number that you recorded from the DSA, then you have located the multi-adapter bridge identified in the DSA.
11. From the Logical Hardware Resources on System Bus display, examine the status of all the resources under the multi-adapter bridge, looking for a "failed" resource.
  - ◆ To examine the status of the IOAs, select Resources associated with IOP for each IOP under the multi-adapter bridge.
  - ◆ To determine the card position of a failed resource, select Associated packaging resource(s) > Display detail and record the frame ID, card position, and part number.

Did you find any failed resources?

- ◆ Yes: One of the failing resources that you located is the problem. Return to the procedure that sent you here. This ends the procedure.
- ◆ No: Use the System Configuration Listing and the [card position tables](#) for the frame type that you recorded to determine which card positions may have the failing card. If you recorded that the multi-adapter bridge was identified in the leftmost character of the CC value, then the [card position tables](#) will help you identify which card slots (PCI bridge set) are controlled by the multi-adapter bridge that is identified in the CC value. If the multi-adapter bridge was not identified in the CC value (indicated by a value of '0' in the leftmost character) then the [card position tables](#) will identify which card slots are controlled by the bus (BBBB) that is identified in the DSA. Return to the procedure that sent you here. This ends the procedure.

12. Perform the following:
  - a. Convert the hexadecimal CC value in the DSA into a decimal value. You will be searching for the decimal value in HSM where it will be called "System card".
  - b. Sign on to SST or DST if you have not already done so.
  - c. Select Start a Service Tool > Hardware Service Manager > Logical Hardware Resources > System Bus Resources.
  - d. Search for the "System Bus" resource identified in BBBB of the DSA by moving the cursor to each system bus resource and selecting Display detail. Do this until you locate the bus number that matches the decimal bus number value that you recorded from the DSA. Record the resource name of the bus for later use.
  - e. From the Logical Hardware Resources on System Bus display, select Include non-reporting resources.

13. From the Logical Hardware Resources on System Bus display, examine all of the IOP and IOA resources under the bus. Look for a "System card" value that matches the decimal value of the CC that you converted to decimal in step 12. Perform the following to display the "System card" value for each of the IOP and IOA resources:
- ◆ To examine the IOP resources:
    - a. Select Associated packaging resource(s) > Display detail. The "System card" value of the IOP will be shown on the display.
    - b. If the "System card" value matches the decimal value of the CC, then you have located the failing resource. Record the frame ID, card position, and part number, and then return to the procedure that sent you here. Otherwise, continue to examine all the IOP and IOA resources on the bus.
  - ◆ To examine the IOA resources:
    - a. Move the cursor to an IOP resource and select Resources associated with IOP > Associated packaging resource(s) > Display detail. The "System card" value of the IOA will be shown on the display.
    - b. If the "System card" value matches the decimal value of the CC, then you have located the failing resource. Record the frame ID, card position, and part number, and then return to the procedure that sent you here. Otherwise, continue to examine all the IOP and IOA resources on the bus.

Have you examined all the IOP and IOA resources under the bus?

- ◆ No: Repeat step 13.
  - ◆ Yes: Continue with the next step.
14. Did you locate a resource with a "System card" value that matches the decimal CC value from step 12?
- ◆ Yes: Record the frame ID, card position, and part number of the resource. Return to the procedure that sent you here. This ends the procedure.
  - ◆ No: You will not be able to locate the card using DST. Go to step 7 to locate the card.

## MABIP54

Use this procedure to isolate the failing PCI I/O adapter card from a reference code with a Direct Select Address when the serviceable event view does not indicate a location for the PCI card.

### Attention:

- This procedure is for use with only. Go to [PCI bus isolation using AIX, Linux, or the HMC](#) to isolate a PCI bus problem from AIX, Linux, or the HMC.
- The removal and replacement of all FRUs in this procedure must be performed using dedicated maintenance.

1. Determine the PCI bridge set (multi-adapter bridge domain) by performing the following:
  - a. Record the bus number (BBBB), the multi-adapter bridge number (C), and the multi-adapter bridge function number (c) from the Direct Select Address (DSA) (see [Breaking down a RIO/HSL or PCI bus reference code](#) for help in determining these values).
  - b. Using the bus number and the System Configuration Listing, or by asking the customer, determine which unit the bus is located in and record that unit type.
  - c. The PCI bridge set is the group of card positions controlled by the same multi-adapter bridge on the bus that you recorded. Use the System Configuration Listing, the [card position table](#) for the unit type that you recorded, the bus number, and the multi-adapter bridge number to determine in which PCI bridge set the failure occurred.
  - d. Print out the [Installed features in a PCI bridge set form](#).
  - e. Using the card position table, record the PCI bridge set card positions, and the multi-adapter bridge function numbers on the form.
  - f. Examine the PCI bridge set and record the information on the form for all of the positions with IOP and IOA cards installed in them.

- g. The IOP with a failing IOA is in the card position that matches the multi-adapter bridge function number that you recorded in the DSA. In the "IOP" or "IOA" column of the form, write the word "DSA" next to the IOP that is identified in the DSA.
- h. Using the form, start at the card position for the IOP in the DSA and search down the "IOP" or "IOA" column (increasing multi-adapter bridge function numbers) and mark each IOA with an "X" until you hit the next IOP or the bottom of the column. The IOAs that you marked with "X" are all under the control of the IOP that is indicated in the DSA.
2. Did the reference code appear on the system control panel or the system console?
- ◆ No: When this procedure instructs you to power on the system or partition, power off or power on only the partition that reported the problem. On a multiple partition system, use interfaces on the HMC to power on or power off the partition or to perform concurrent maintenance. On a single partition system use the operating system interface to power on or power off the system. Use this procedure to find the correct remove and replace procedure for each card position that you are instructed to work with. Continue with the next step.
  - ◆ Yes: This procedure will instruct you to power off and power on the system or partition with the problem. Perform that function as you would normally power off and power on the system. Continue with the next step.
3. Perform the following:
- a. Power off the system or partition.
  - b. Remove all of the IOAs that you marked with an "X" on the [Installed features in a PCI bridge set form](#). Be sure to record the card position of each IOA so that you can reinstall it in the same position later. To determine the remove and replace procedures for the IOAs, locate the IOA card positions in the [FRU locations and failing items table](#) for the frame type that you recorded.
  - c. Power on the system or partition.
- Does the reference code or failure that sent you to this procedure occur?
- ◆ Yes: Continue with the next step.
  - ◆ No: Power off the system or partition. Go to step 7.
4. Perform the following:
- a. Power off the system or partition.
  - b. Exchange the IOP that is indicated in the DSA. Be sure to record the card position of the IOP so that you can reinstall it in the same position later. To determine the exchange procedure for the IOP, locate the IOP's card position in the [FRU locations and failing items table](#) for the frame type you recorded.
  - c. Power on the system or partition.
- Does the reference code or failure that sent you to this procedure occur?
- ◆ No: Continue with the next step.
  - ◆ Yes: Go to step 11.
5. Perform the following:
- a. Power off the system or partition.
  - b. Install all of the IOAs that you removed in step 3. Be sure to install them in their original positions.
  - c. Power on the system or partition.
- Does the reference code or failure that sent you to this procedure occur?
- ◆ Yes: Continue with the next step.
  - ◆ No: Perform [Verifying a high-speed link, system PCI bus, or a multi-adapter bridge repair](#).
- This ends the procedure.
6. Perform the following:
- a. Power off the system or partition.
  - b. Remove all of the IOAs that you marked with an "X" on the [Installed features in a PCI bridge set form](#). Be sure to record the card position of each IOA so that you can reinstall it in the same position later.
  - c. Remove the IOP that you exchanged and install the original IOP in its original position. Continue with the next step.
7. Perform the following:
- a. Reinstall, in its original position, one of the IOAs that you removed.
  - b. Power on the system or partition.
- Does the reference code or failure that sent you to this procedure occur?
- ◆ Yes: The IOA that you just installed is the failing FRU. Continue with the next step.
  - ◆ No: Power off the system or partition. Repeat step 7 for another one of the IOAs that you removed. If you have reconnected all of the IOAs and the reference code or failure that sent you to this procedure does not occur, the problem is intermittent; contact your next level of

support.

This ends the procedure.

8. Perform the following:
  - a. Power off the system or partition.
  - b. Exchange the I/O adapter card that you last installed. Be sure to install the new I/O adapter card in the same position.
  - c. Power on the system or partition.

Does the reference code or failure that sent you to this procedure occur?

- ◆ No: Continue with the next step.
- ◆ Yes: Call your next level of support.

This ends the procedure.

9. Perform the following:
  - a. Power off the system or partition.
  - b. Reinstall, in their original positions, the remaining I/O adapter cards that you removed.

Does the reference code or failure that sent you to this procedure occur?

- ◆ Yes: Call your next level of support.

This ends the procedure.

10. Does a different reference code occur?
  - ◆ No: Continue with the next step.
  - ◆ Yes: Return to [Start of call procedure](#) and follow the service procedures for the new reference code.

This ends the procedure.

- ◆ No: Perform [Verifying a high-speed link, system PCI bus, or a multi-adapter bridge repair](#).

This ends the procedure.

11. The problem is the multi-adapter bridge. Perform the following to determine which FRU contains the multi-adapter bridge that controls the IOP in the DSA:
  - a. Power off the system or partition.
  - b. Locate the [card position table](#) for the frame type that you recorded.
  - c. Using the multi-adapter bridge number that you recorded, search for the multi-adapter bridge function number "F" in the card position table to determine the card position of the multi-adapter bridge's FRU.

Have you already exchanged the multi-adapter bridge's FRU?

- ◇ No: Continue with the next step.
- ◇ Yes: Call your next level of support.

This ends the procedure.

12. Perform the following:
  - a. Remove the IOP that you exchanged.
  - b. Exchange the multi-adapter bridge's FRU at the card position that you determined for it. To determine the exchange procedure for the multi-adapter bridge's FRU, locate the FRU's card position in the [FRU locations and failing items table](#) for the frame type that you recorded.
  - c. Install the original IOP in its original position.
  - d. Install all of the other IOPs and IOAs into their original positions. Do not install the IOAs that you were instructed to remove in step 3.
  - e. Power on the system or partition.

Does the reference code or failure that sent you to this procedure occur?

- ◆ No: Continue with the next step.
- ◆ Yes: Call your next level of support.

This ends the procedure.

13. Perform the following:
  - a. Install all of the IOAs that you removed in step 3. Be sure to install them in their original positions.
  - b. Power on the system or partition.

Does the reference code or failure that sent you to this procedure occur?

- ◆ No: The problem has been resolved.

This ends the procedure.

- ◆ Yes: Call your next level of support.

This ends the procedure.

## MABIP55

Use this procedure to isolate a failing I/O adapter.

**Attention:** This procedure is for use with only. Go to [PCI bus isolation using AIX, Linux, or the HMC](#) to isolate a PCI bus problem from AIX, Linux, or the HMC.

This procedure iterates through each IOA without an IOP, then each IOA under the IOP, powers each one off, and then resets the IOP. This process repeats until it isolates the failing IOA.

1. If the system is not IPLed, will it IPL to DST?
  - ◆ No: Perform [MABIP54](#). This ends the procedure.
  - ◆ Yes: From the SAL display for the reference code, record the count. Continue with the next step.
2. Go to the SST/DST display in the partition which reported the problem. Use STRSST if is running; use function 21 if STRSST does not work; or IPL the partition to DST.
3. On the Start Service Tools Sign On display, type in a user ID with QSRV authority and password.
4. Select Start a service tool > Hardware service manager > Logical hardware resources > System bus resources.
5. Is there a resource name logged in the SAL entry?
  - ◆ No: Continue with the next step.
  - ◆ Yes: Go to step [12](#).
6. Do you have a location for the I/O processor?
  - ◆ No: Record the Direct Select Address (DSA), word 7 of the reference code, from the SAL display. Then continue with the next step.
  - ◆ Yes: Go to step [10](#).
7. Return to the HSM System bus resources display.
8. Locate the I/O processor by performing the following:
  - a. Select Display detail.
  - b. Compare the DSA with the bus, card, and board information for the IOP.

**Note:** The card information on the HSM display is in decimal format. You must convert the decimal card information to hexadecimal format to match the DSA format.

| Decimal format | Hexadecimal format |
|----------------|--------------------|
| 16             | 10                 |
| 17             | 11                 |
| 18             | 12                 |
| 19             | 13                 |
| 20             | 14                 |
| 21             | 15                 |
| 22             | 16                 |
| 23             | 17                 |

- c. Repeat this step until you find the IOP with the same DSA.
9. Select Cancel, and then go to step 13.
10. Locate the I/O processor in HSM by performing the following for each IOP:
  - a. Select Associated packaging resource(s) > Display detail.
  - b. Repeat until you find the IOP with the same location.
11. Select Cancel > Cancel and go to step 13.
12. Page forward until you find the multi-adapter bridge and IOP where the problem exists. Verify that the multi-adapter bridge and IOP are correct by matching the resource name(s) on the display with the resource name(s) in the SAL for the problem you are working on.
13. For the IOP you are working on, select Resources associated with IOP (if the I/O adapters are not already displayed).
14. If there is an IOA that is listed in any state other than *"operational"*, then perform steps 15 through 18, starting with the disabled IOA by moving the cursor to the disabled IOA. Otherwise, move the cursor to the first IOA that is assigned to the IOP.
15. Select Associated packaging resource(s) > Concurrent maintenance > Power off domain.

Record the frame ID and location of the slot you are powering off. Did the domain power off successfully?

- ◆ No: Choose from the following options:
    - ◇ If only one IOA was listed as failing, power down the system and replace the IOA. Re-IPL the system. If a different reference code occurred, go to [Start of call procedure](#) and work that reference code. If there was no reference code, go to [Verifying the repair](#). This ends the procedure.
    - ◇ If there were multiple failed IOAs and concurrent maintenance did not work on one, then move to the next failed IOA and repeat steps 15 through 18.
    - ◇ If concurrent maintenance does not work for multiple failed IOAs, this procedure will not be able to identify a failing I/O adapter. Return to the procedure that sent you here. This ends the procedure.
  - ◆ Yes: Perform [MABIP05](#) and then return here and continue with the next step.
16. Did the IOP reset and IPL successfully?
    - ◆ No: This procedure will not be able to identify a *failing* I/O adapter. Return to the procedure that sent you here. This ends the procedure.
    - ◆ Yes: Check for the same failure that sent you to this procedure. Check the system control panel, the SAL for the partition that reported the problem, or the Work with partition status display for the partition that reported the problem. In the SAL, the count will increase if the reference code occurred again. Continue with the next step.
  17. Did the same reference code occur after the IOP was reset and IPL'd?
    - ◆ No: Go to step 19.
    - ◆ Yes: Perform the following:
      - a. Go to the Hardware Service Manager display.
      - b. Go to Packaging Hardware Resources.
      - c. Power on the IOA by selecting Power on domain.
      - d. Reassign the IOA to the IOP.
      - e. Return to the HSL resource display, showing the IOP and associated resources.
      - f. Continue with the next step.
  18. Is there any other IOA, assigned to the IOP, that you have not already powered off and on?
    - ◆ No: Go to step 21.
    - ◆ Yes: Move the cursor to another IOA assigned to the IOP, choosing IOAs with a status of *"unknown"* or *"disabled"* before moving on to IOAs with a status of *"operational"*. Go to step 15.
  19. The failing IOA is located. Exchange the I/O adapter that you just powered off. Use the location you recorded in step 15 to locate the IOA.
  20. Power on the IOA that you just exchanged. Does the same reference code that sent you to this procedure still occur?
    - ◆ Yes: The IOA is not the failing item. Remove the IOA and reinstall the original IOA. Continue with the next step.
    - ◆ No: You have exchanged the failing IOA. Go to [Verifying a high-speed link, system PCI bus, or a multi-adapter bridge repair](#). This ends the procedure.
  21. No failing IOAs were identified. Return to the procedure that sent you here. This ends the procedure.
-

## MABIP02

Use this procedure to determine if the multi-adapter bridge is failing when the symbolic FRU PIOCARD is in the failing item list, with other failing items that have a multi-adapter bridge as a component.

The procedure will start with the failing item list for the SRC that sent you here. It will determine if PIOCARD should be removed from the failing item list that you are working in.

Use the Service Action Log (SAL) to check for other errors under the same multi-adapter bridge. See [Using the Service Action Log](#) for details.

1. Were you able to obtain a location for the PIOCARD FRU from the SAL?
    - ◆ Yes: Go to step 5.
    - ◆ No: Find the SRC in the SAL and record the Direct Select Address (DSA) in word 7. See [Breaking down a RIO/HSL or PCI bus reference code](#) to find the DSA in the SRC. Then continue with the next step.
  2. Record the Bus number (BBBB part) of the DSA and the Multi-adapter bridge number of the DSA. The multi-adapter bridge number is the first character of the card identifier part (Cc) in the DSA. See [Breaking down a RIO/HSL or PCI bus reference code](#) to find the DSA in the SRC.
  3. Go to [MABIP53](#) to determine the location of the PCI I/O Card in the failing item list. Return here and continue with the next step.
  4. Using the card position table for the frame or I/O unit type that you recorded in [MABIP53](#), determine which of the card positions within the frame or I/O unit are controlled by the same multi-adapter bridge that is controlling the PCI I/O card for which you determined the location in step 3. See [Card positions](#). A card position is controlled by the same multi-adapter bridge if it has the same bus number and multi-adapter bridge number as the PCI I/O Card that you located in step 3. Record the card position and the DSA from the card position table for each card position that is controlled by the same multi-adapter bridge.
  5. Look in the SAL for other failures in the same I/O unit that are located in any of the card positions that either you recorded in step 4 or that are listed in the SAL with the PIOCARD FRU.
  6. Are there any other failures within the same I/O unit that correspond with any of the card positions that you recorded in step 4 or that are listed in the SAL with the PIOCARD FRU?
    - ◆ No: Use the failing item list that you were using when you started this procedure.
    - ◆ Yes: The multi-adapter bridge is failing. Remove symbolic FRU PIOCARD from the list of failing items, it is not the failing FRU.
- 

## MABIP03

Use this procedure to isolate a failing I/O processor or I/O adapter under a multi-adapter bridge.

The PCI cards will all be in a PCI bridge set. The serviceable event view you are working with may have all the PCI adapter locations for the PCI bridge set listed. The procedure will iterate through each IOP under the multi-adapter bridge, powering each one off, and then resetting the multi-adapter bridge. This process will be repeated until the failing part is isolated.

1. Does the system IPL to DST?
  - ◆ Yes: Go to the SST/DST display in the partition which reported the problem:
    - ◇ If is running, use STRSST.
    - ◇ If STRSST does not work, use function 21.
    - ◇ Or IPL the partition to DST.
 Then, continue with the next step.
  - ◆ No: Perform [MABIP04](#). This ends the procedure.
2. On the Start Service Tools Sign On display, type in a user ID with service authority and password.
3. Select Start a service tool > Hardware service manager > Logical hardware resources > System bus resources.
4. The resource name may be in the serviceable event view or you may have determined the resource name already in another procedure. Do you have the resource name where the problem was



reported?

- ◆ Yes: Continue with the next step.
- ◆ No: Perform the following:
  - a. Record the bus number, which is the first four characters of word 7 in the SRC.
  - b. Convert the bus number from hexadecimal to decimal format using a calculator or similar tool that provides a conversion function.
  - c. Select Display Details for each system bus until you locate the bus with a matching decimal bus number. The multi-adapter bridge that reported the problem is a resource on that bus. Continue with the next step.
- 5. Page forward until you find the multi-adapter bridge where the problem was reported (for help with identifying the multi-adapter bridge from reference code, see [DSA translation](#)). Verify that the multi-adapter bridge is the correct one by matching the resource name on the display with the resource name in the Service Action Log (SAL) for the problem that you are working on.
- 6. Select Include non-reporting resources.
- 7. Move the cursor to the first IOP under the multi-adapter bridge.
- 8. For each IOP that is under the multi-adapter bridge that you are working on, select Associated packaging resource(s) > Display detail.
- 9. Record the location of the I/O processor (IOP).
- 10. Select Cancel > Cancel.
- 11. Select Resources associated with IOP.
- 12. For each I/O adapter under the IOP, perform the following:
  - a. Select Associated packaging resource(s) > Display detail.
  - b. Record the location. Then continue with the next step.
- 13. Perform the following:
  - a. Power off the frame or expansion unit (see [Powering on and powering off](#)).
  - b. Remove one of the IOPs and all of its IOAs.
  - c. Power on the frame or expansion unit (see [Powering on and powering off](#)).

Check for the same failure that brought you to this procedure. Check the system control panel, the Service Action Log (SAL) for the partition which reported the problem, or the Work with partition status display for the partition that reported the problem. Did the same SRC appear after the frame or expansion unit was powered on?

◇ Yes: Continue with the next step.

◇ No: Go to step [15](#).

14. Perform the following:
  - a. Power on the frame or expansion unit (see [Powering on and powering off](#)).
  - b. Return to the System bus resources display showing the multi-adapter bridge and the associated resources.

Is there another IOP under the multi-adapter bridge?

◇ No: Go to step [17](#).

◇ Yes: Go to step [13](#).

15. The failing item is either the I/O processor or one of the I/O adapters that it controls. Perform the following:
  - a. Reinstall the IOP and I/O adapters that you just removed.
  - b. Perform [MABIP06](#).
  - c. If you are unable to identify a failing I/O adapter with [MABIP06](#), then return here and continue with the next step in this procedure.
16. Perform the following:
  - a. Exchange the I/O processor that you identified in step [15](#).
  - b. Power on the frame or expansion unit (see [Powering on and powering off](#)).

Does the same SRC that sent you to this procedure occur?

  - ◆ No: The failing item was the IOP that you just exchanged. Reinstall all of the other IOPs and I/O adapters that you removed during this procedure. Go to [Verifying a high-speed link, system PCI bus, or a multi-adapter bridge repair](#). This ends the procedure.
  - ◆ Yes: The failing item is the FRU containing the multi-adapter bridge which controls this IOP. Continue with the next step.
17. There are no failing IOPs. The failing item is the FRU containing the multi-adapter bridge that controls this IOP. Perform the following:
  - a. Power off the system or expansion unit that you are working in (see [Powering on and powering off](#)).
  - b. Exchange the FRU containing the multi-adapter bridge using symbolic FRU [MA\\_BRDG](#).
  - c. Power on the system or expansion unit that you are working in (see [Powering on and powering off](#)).

Does the same SRC that sent you to this procedure occur?

- ◆ No: The failing item was the multi-adapter bridge FRU that you just exchanged. Reinstall all of the other IOPs and I/O adapters that you removed during this procedure. Go to [Verifying a high-speed link, system PCI bus, or a multi-adapter bridge repair](#). This ends the procedure.
  - ◆ Yes: Contact your next level of support. This ends the procedure.
- 

## MABIP04

Use this procedure to isolate a failing PCI I/O processor (IOP) card from a reference code, when the system or logical partition will not IPL.

**Attention:** The exchange procedure of all FRUs in this procedure must be performed using dedicated maintenance.

1. Determine the PCI bridge set by performing the following:
  - a. Record the bus number (BBBB), the multi-adapter bridge number (C), and the multi-adapter bridge function number (c) from the Direct Select Address (DSA) in word 7 of the reference code in the SAL entry (see [DSA translation](#) for help in determining these values).
  - b. Use the bus number that you recorded and the System Configuration Listing, or ask the customer, to determine what frame the bus is in. Record the frame type where the bus is located.
  - c. The PCI bridge set is the group of card positions controlled by the same multi-adapter bridge on the bus that you recorded. Use the System Configuration Listing, the [card position table](#) for the frame type that you recorded, the bus number, and the multi-adapter bridge number to determine the PCI bridge set where the failure occurred.
  - d. Print out the [Installed features in a PCI bridge set form](#) to use in the following steps.
  - e. Using the card position table, record the PCI bridge set card positions and multi-adapter bridge function numbers in the form.
  - f. Examine the PCI bridge set in the frame, and record the information in the form for all of the positions with IOP and IOA cards installed in them.
  - g. In the form, start at the top row and search down the "IOP" or "IOA" column (increasing multi-adapter bridge function numbers) and mark each IOP with an "X" until you hit the bottom of the column. The IOPs that you marked with "X" are all under the control of the multi-adapter bridge indicated in the DSA.
2. Did the reference code appear on the system control panel (this would happen if the system does not have multiple partitions)?
  - ◆ No: When this procedure instructs you to power off and power on the system or partition, power off or power on only the partition that reported the problem. Then use HSM concurrent maintenance to power off the card positions that you are instructed to work with. The exchange procedures for those positions will guide you through the HSM concurrent maintenance functions. This procedure will guide you to the correct exchange procedure for each card position that you are instructed to work with. Continue with the next step.
  - ◆ Yes: This procedure instructs you to power off and power on the system or partition with the problem. Perform that function as you would normally power off and power on the system. Continue with the next step.
3. Power off the system or partition.
4. Remove all the IOPs you marked with an "X" and all the IOAs in the form. Be sure to record the card position of each IOP and IOA so that you can reinstall it in the same position later. To determine the exchange procedures for the IOPs and IOAs, locate the card positions in the FRU locations and failing items table for the frame type you recorded (see [Finding part locations](#)).
5. Power on the system or partition.

Does the reference code or failure that sent you to this procedure occur?

- ◆ No: Continue with the next step.
- ◆ Yes: The problem is the multi-adapter bridge. Continue with step [13](#).

6. Starting at the empty card position with the lowest multi-adapter bridge function number from the form, reinstall, in their original positions, one of the IOPs and all the IOAs between it and the next IOP.
7. Power on the system or partition. Does the reference code or failure that sent you to this procedure occur?
  - ◆ Yes: The IOP that you just installed is the failing FRU. Continue with the next step.
  - ◆ No: Power off the system or partition. Repeat step 6 for another one of the I/O processor cards that you removed. If you have reconnected all of the IOPs and the reference code or failure that sent you to this procedure does not occur, the problem is intermittent (see [Intermittent problems](#)). This ends the procedure.
8. Power off the system or partition.
9. Exchange the I/O processor card you last installed. Be sure to install the new I/O processor card in the same position.
10. Power on the system or partition.

Does the reference code or failure that sent you to this procedure occur?

- ◆ No: Power off the system or partition. Then continue with the next step.
  - ◆ Yes: Remove the IOP that you just installed and replace the original IOP in its original position. Perform [MABIP07](#). This ends the procedure.
11. Reinstall, in their original positions, the remaining IOP and IOA cards that you removed.

Does the reference code or failure that sent you to this procedure occur?

- ◆ Yes: Call your next level of support. This ends the procedure.
  - ◆ No: Continue with the next step.
12. Does a different reference code occur?
    - ◆ Yes: Follow the service procedures for the new reference code (go to [Start of call procedure](#)). This ends the procedure.
    - ◆ No: Perform [Verifying a high-speed link, system PCI bus, or a multi-adapter bridge repair](#). This ends the procedure.
  13. Power off the system or partition.
  14. Determine which FRU contains the multi-adapter bridge that controls the IOP in the DSA by locating the [card position table](#) for the frame type that you recorded. Using the multi-adapter bridge number that you recorded, search for the multi-adapter bridge function number "F" in the card position table to determine the card position of the multi-adapter bridge's FRU.
  15. Have you already exchanged the multi-adapter bridge's FRU?
    - ◆ No: Remove the IOP that you exchanged. You will be reinstalling the original IOP later in this procedure. Then continue with the next step.
    - ◆ Yes: Call you next level of support. This ends the procedure.
  16. Exchange the card multi-adapter bridge's FRU at the card position that you determined for it. To determine the exchange procedure for the multi-adapter bridge's FRU, locate the FRU's card position in the FRU locations and failing items table for the frame type that you recorded (see [Finding part locations](#)).
  17. Install all IOPs and IOAs in their original positions.
  18. Power on the system or partition.

Does the reference code or failure that sent you to this procedure occur?

- ◆ No: Perform [Verifying a high-speed link, system PCI bus, or a multi-adapter bridge repair](#). This ends the procedure.
- ◆ Yes: Call your next level of support. This ends the procedure.

## Breaking down a RIO/HSL or PCI bus reference code

Word 7 of the reference code allows you to determine the correct bus number, bus type, multi-adapter bridge number, multi-adapter bridge function number, and logical card number from the Direct Select Address (DSA).

Physical card slot labels and card positions for PCI buses are determined by using the DSA and the appropriate system unit or I/O unit card positions. See [Card positions](#) for details.

Table 1. RIO/HSL and PCI reference code breakdown

| Word of the reference code            | Control panel function | Panel function characters | Format                 | Description                                                    |
|---------------------------------------|------------------------|---------------------------|------------------------|----------------------------------------------------------------|
| 1                                     | 11                     | 1 8                       | B600 uuuu or B700 uuuu | uuuu = unit reference code (69xx)                              |
| 1 extended reference code information | 11                     | 9 16                      | iiii                   | Frame ID of the failing resource                               |
| 1 extended reference code information | 11                     | 17 24                     | ffff                   | Frame location                                                 |
| 1 extended reference code information | 11                     | 25 32                     | bbbb                   | Board position                                                 |
| 2                                     | 12                     | 1 8                       | MIGVEP62 or MIGVEP63   | See <a href="#">Hardware SRC formats</a> .                     |
| 3                                     | 12                     | 9 16                      | cccc cccc              | Component reference code                                       |
| 4                                     | 12                     | 17 24                     | pppp pppp              | Programming reference code                                     |
| 5                                     | 12                     | 25 32                     | qqqq qqqq              | Program reference code high order qualifier                    |
| 6                                     | 13                     | 1 8                       | qqqq qqqq              | Program reference code low order qualifier                     |
| 7                                     | 13                     | 9 16                      | BBBB Ccbb              | See <a href="#">DSA translation</a>                            |
| 8                                     | 13                     | 17 24                     | TTTT MMMM              | Type (TTTT) and model (MMMM) of the failing item (if not zero) |
| 9                                     | 13                     | 25 32                     | uuuu uuuu              | Unit address (if not zero)                                     |

Parent topic: [Bus, high-speed link \(HSL or RIO\) isolation procedures](#)

## DSA translation

The Direct Select Address (DSA) may be coded in word 7 of the reference code.

This is either a PCI system bus number or a RIO loop number, depending on the type of error. With the information obtained here, and the information in either the card position table (for PCI bus numbers) or the information in the loop-number-to-NIC-port table (for RIO loop numbers), you should be able to isolate a failing PCI bus or RIO loop. Follow the instructions below to translate the DSA:

- Break down the DSA into the bus number, multi-adapter bridge number, and multi-adapter bridge function number as shown in tables below. The DSA is of the form BBBB Ccxx, and breaks down into the following parts:
  - ◆ BBBB = bus number
  - ◆ C = multi-adapter bridge number
  - ◆ c = multi-adapter bridge function number
  - ◆ xx = not used
- Is the bus number less than 0684?
  - ◆ Yes: The bus number is a PCI bus number. Refer to [PCI bus numbers](#) to convert the number to decimal, and then continue with the next step.
  - ◆ No: The bus number is a RIO loop number. Refer to [RIO loop numbers](#) to convert the number to decimal, and then continue with the next step.

3. Use one of the following guides to determine if the bus is located in the system unit or expansion unit:
  - ◆ If you are using an interface, use the System Configuration List or Hardware Service Manager (HSM).
  - ◆ If you are using a Hardware Management Console (HMC) interface, view the managed system's properties on the HMC.
4. Perform one of the following:
  - ◆ Refer to [Card positions](#) to search for the bus number, the multi-adapter bridge number, and the multi-adapter bridge function number that matches the system unit or I/O tower type where the bus is located. This ends the procedure.
  - ◆ Refer to [Converting the loop number to NIC port location labels](#) to determine the starting ports for the RIO loop with the failed link. This ends the procedure.

Table 1. PCI bus numbers

| Bus number in hexadecimal (BBBB) | Bus number in decimal  | Multi-adapter bridge number (C) | Multi-adapter bridge function number (c) |
|----------------------------------|------------------------|---------------------------------|------------------------------------------|
| 0001                             | 1                      | 1                               | 0 through 7                              |
| 0001                             | 1                      | 2                               | 0 through 7                              |
| 0001                             | 1                      | 7                               | 0                                        |
| 0002 - 0007                      | 2 - 7                  | 1                               | 0 through 7                              |
| 0002 - 0007                      | 2 - 7                  | 2                               | 0 through 7                              |
| 0008 and 0009                    | 8 through 9 (not used) |                                 |                                          |
| 0016 through 03FF                | 16 through 1023        | 1                               | 0 through 7                              |
| 0016 through 03FFF               | 16 through 1023        | 2                               | 0 through 7                              |

Table 2. RIO loop numbers

| Bus number in hexadecimal (BBBB) | RIO loop number in decimal | RIO loop number as seen in HSM |
|----------------------------------|----------------------------|--------------------------------|
| 0684 through 0689                | 1668 through 1673          | 668 through 673                |
| 068A through 068F                | 1674 through 1679          | 674 through 679                |
| 0690 through 0699                | 1680 through 1689          | 680 through 689                |
| 069A through 069F                | 1690 through 1695          | 690 through 695                |
| 06A0 through 06A9                | 1696 through 1705          | 696 through 705                |
| 06AA through 06AF                | 1706 through 1711          | 706 through 711                |
| 06B0 through 06B9                | 1712 through 1721          | 712 through 721                |
| 06BA through 06BF                | 1722 through 1727          | 722 through 727                |
| 06C0 through 06C9                | 1728 through 1737          | 728 through 737                |
| 06CA through 06CF                | 1738 through 1743          | 738 through 743                |
| 06D0 through 06D9                | 1744 through 1753          | 744 through 753                |
| 06DA through 06DF                | 1754 through 1759          | 754 through 759                |
| 06E0 through 06E9                | 1760 through 1769          | 760 through 769                |
| 06EA through 06EF                | 1770 through 1775          | 770 through 775                |
| 06F0 through 06F9                | 1776 through 1785          | 776 through 785                |
| 06FA through 06FF                | 1786 through 1791          | 786 through 791                |
| 0700 through 0709                | 1792 through 1801          | 792 through 801                |
| 070A through 070F                | 1802 through 1807          | 802 through 807                |
| 0710 through 0719                | 1808 through 1817          | 808 through 817                |
| 071A through 071F                | 1818 through 1823          | 818 through 823                |

Service provider information

|                   |                   |                 |
|-------------------|-------------------|-----------------|
| 0720 through 0729 | 1824 through 1833 | 824 through 833 |
| 072A through 072F | 1834 through 1839 | 834 through 839 |
| 0730 through 0739 | 1840 through 1849 | 840 through 849 |
| 073A through 073F | 1850 through 1855 | 850 through 855 |
| 0740 through 0749 | 1856 through 1865 | 856 through 865 |
| 074A through 074F | 1866 through 1871 | 866 through 871 |
| 0750 through 0759 | 1872 through 1881 | 872 through 881 |
| 075A through 075F | 1882 through 1887 | 882 through 887 |
| 0760 through 0769 | 1888 through 1897 | 888 through 897 |
| 076A through 076F | 1898 through 1903 | 898 through 903 |
| 0770 through 0779 | 1904 through 1913 | 904 through 913 |
| 077A through 077F | 1914 through 1919 | 914 through 919 |
| 0780 through 0789 | 1920 through 1929 | 920 through 929 |
| 078A through 078F | 1930 through 1935 | 930 through 935 |
| 0790 through 0799 | 1936 through 1945 | 936 through 945 |
| 079A through 079F | 1946 through 1951 | 946 through 951 |
| 07A0 through 07A9 | 1952 through 1961 | 952 through 961 |
| 07AA through 07AF | 1962 through 1967 | 962 through 967 |
| 07B0 through 07B9 | 1968 through 1977 | 968 through 977 |
| 07BA through 07BF | 1978 through 1983 | 978 through 983 |
| 07C0 through 07C9 | 1984 through 1993 | 984 through 993 |
| 07CA through 07CF | 1994 through 1999 | 994 through 999 |
| 07D0 through 07D9 | 2000 through 2009 | 000 through 009 |
| 07DA through 07DF | 2010 through 2015 | 010 through 015 |
| 07E0 through 07E9 | 2016 through 2025 | 016 through 025 |
| 07EA through 07EF | 2026 through 2031 | 026 through 031 |
| 07F0 through 07F9 | 2032 through 2041 | 032 through 041 |
| 07FA through 07FE | 2042 through 2046 | 042 through 046 |

**Parent topic:** [Bus, high-speed link \(HSL or RIO\) isolation procedures](#)

---

## Card positions

The following information specifies card positions for the various server models.

Use the table for the model you are working on:

- [Model ESCALA PL 250T/R](#)
- [Model ESCALA PL 450T/R](#)
- [Model ESCALA PL 850R/PL 1650R/R+](#)
- [Model 5/75](#)
- [50/74, 50/79, 8079-002, and 8093-002 expansion units](#)
- [50/88, 05/88, 50/94, 52/94, and 8094-002](#)
- [50/95, 05/95, and 11D/20 expansion units](#)
- [11D/10 and 11D/11 expansion units](#)
- [406/1D expansion unit](#)

**Notes:**

Service provider information

1. Service 50/79 expansion units as two independent 50/74 units.
2. Service 52/94 expansion units as two independent 50/94 units.

Table 1. Card positions for model ESCALA PL 250T/R

| Bus number in DSA (hexadecimal) | Multi-adapter bridge number in DSA | Multi-adapter bridge function number in DSA | Item DSA points to           | Position label and PCI data width |
|---------------------------------|------------------------------------|---------------------------------------------|------------------------------|-----------------------------------|
| 0001                            | 7                                  | 0                                           | Service processor            | -P1-C7                            |
| 0002                            | 2                                  | 0                                           | PCI IOP or IOA card          | -P1-C1 (64 bit)                   |
|                                 | 2                                  | 1                                           |                              | -P1-C1 (64 bit)                   |
|                                 | 2                                  | 2                                           |                              | -P1-C2 (32 bit)                   |
|                                 | 2                                  | 3                                           | Embedded USB controller      | -P1 (32 bit)                      |
|                                 | 2                                  | 4                                           | Embedded Ethernet controller | -P1 (64 bit)                      |
|                                 | 2                                  | 5                                           |                              |                                   |
|                                 | 2                                  | 6                                           | PCI IOA card                 | -P1-C4 (64 bit)                   |
|                                 | 2                                  | 7                                           |                              | -P1-C4 (64 bit)                   |
|                                 | 2                                  | F                                           | Multi-adapter bridge         | -P1                               |
| 0003                            | 2                                  | 0                                           | PCI IOP or IOA card          | -P1-C6 (64 bit)                   |
|                                 | 2                                  | 1                                           |                              |                                   |
|                                 | 2                                  | 2                                           | PCI IOP or IOA card          | -P1-C3 (32 bit)                   |
|                                 | 2                                  | 3                                           | Embedded IDE controller      | -P1 (32 bit)                      |
|                                 | 2                                  | 4                                           | Embedded SCSI controller     | -P1 (64 bit)                      |
|                                 | 2                                  | 5                                           |                              |                                   |
|                                 | 2                                  | 6                                           | PCI IOA card                 | -P1-C5 (64 bit)                   |
|                                 | 2                                  | 7                                           |                              |                                   |
|                                 | 2                                  | F                                           | Multi-adapter bridge         | -P1                               |

Table 2. Card positions for model ESCALA PL 450T/R

| Bus number in DSA (hexadecimal) | Multi-adapter bridge number in DSA | Multi-adapter bridge function number in DSA | Item DSA points to      | Position label and PCI data width |
|---------------------------------|------------------------------------|---------------------------------------------|-------------------------|-----------------------------------|
| 0001                            | 7                                  | 0                                           | Service processor       | -P1                               |
| 0002                            | 2                                  | 0                                           | PCI IOP or IOA card     | -P1-C3 (64 bit)                   |
|                                 | 2                                  | 1                                           |                         |                                   |
|                                 | 2                                  | 2                                           | Embedded USB controller | -P1 (32 bit)                      |
|                                 | 2                                  | 3                                           | Embedded IDE controller | -P1 (32 bit)                      |
|                                 | 2                                  | 4                                           | PCI IOP or IOA card     | -P1-C4 (64 bit)                   |
|                                 | 2                                  | 5                                           |                         |                                   |
|                                 | 2                                  | 6                                           | PCI IOA card            | -P1-C5 (64 bit)                   |
|                                 | 2                                  | 7                                           |                         |                                   |
| 2                               | F                                  | Multi-adapter bridge                        | -P1                     |                                   |
| 0003                            | 2                                  | 0                                           | PCI IOP or IOA card     | -P1-C1 (64 bit)                   |

Service provider information

|   |   |                              |                 |
|---|---|------------------------------|-----------------|
| 2 | 1 |                              |                 |
| 2 | 2 | Embedded Ethernet controller | -P1 (64 bit)    |
| 2 | 3 |                              |                 |
| 2 | 4 | Embedded SCSI controller     | -P1 (64 bit)    |
| 2 | 5 |                              |                 |
| 2 | 6 | PCI IOA card                 | -P1-C2 (64 bit) |
| 2 | 7 |                              |                 |
| 2 | F | Multi-adapter bridge         | -P1             |

Table 3. Card positions for model ESCALA PL 850R/PL 1650R/R+

| Bus number in DSA (hexadecimal) | Multi-adapter bridge number in DSA | Multi-adapter bridge function number in DSA | Item DSA points to           | Position label and PCI data width |
|---------------------------------|------------------------------------|---------------------------------------------|------------------------------|-----------------------------------|
| 0001                            | 7                                  | 0                                           | Service processor            | -P1-C8                            |
|                                 | 2                                  | 0                                           | Embedded SCSI controller     | -P1 (64 bit)                      |
|                                 | 2                                  | 1                                           |                              |                                   |
|                                 | 2                                  | 2                                           | Embedded USB controller      | -P1 (32 bit)                      |
|                                 | 2                                  | 3                                           | Embedded serial adapter      | -P1 (32 bit)                      |
|                                 | 2                                  | 4                                           | Embedded ethernet controller | -P1 (64 bit)                      |
|                                 | 2                                  | 5                                           |                              |                                   |
|                                 | 2                                  | 6                                           | Unused                       | -P1-T10 (64 bit)                  |
|                                 | 2                                  | 7                                           |                              |                                   |
| 2                               | F                                  | Multi-adapter bridge                        | -P1                          |                                   |
| 0002                            | 2                                  | 0                                           | PCI IOP or IOA card          | -P1-C3 (64 bit)                   |
|                                 | 2                                  | 1                                           |                              |                                   |
|                                 | 2                                  | 2                                           |                              | -P1-C4 (64 bit)                   |
|                                 | 2                                  | 3                                           |                              |                                   |
|                                 | 2                                  | 4                                           |                              | -P1-C5 (64 bit)                   |
|                                 | 2                                  | 5                                           |                              |                                   |
|                                 | 2                                  | 6                                           | PCI IOA card                 | -P1-C6 (64 bit)                   |
|                                 | 2                                  | 7                                           |                              |                                   |
|                                 | 2                                  | F                                           | Multi-adapter bridge         | -P1                               |
| 0003                            | 2                                  | 0                                           | PCI IOP or IOA card          | -P1-C1 (64 bit)                   |
|                                 | 2                                  | 1                                           |                              |                                   |
|                                 | 2                                  | 2                                           | Embedded SCSI controller     | -P1 (64 bit)                      |
|                                 | 2                                  | 3                                           |                              |                                   |
|                                 | 2                                  | 4                                           | Embedded IDE controller      | -P1 (32 bit)                      |
|                                 | 2                                  | 5                                           | Unused                       | -P1 (32 bit)                      |
|                                 | 2                                  | 6                                           | PCI IOA card                 | -P1-C2 (64 bit)                   |
|                                 | 2                                  | 7                                           |                              |                                   |
|                                 | 2                                  | F                                           | Multi-adapter bridge         | -P1                               |



Table 4. Card positions for model 5/75

| Bus number | Multi-adapter bridge number in DSA | Multi-adapter bridge function number in DSA | Item DSA points to           | Position label and PCI data width |
|------------|------------------------------------|---------------------------------------------|------------------------------|-----------------------------------|
| 0001       | 7                                  | 0                                           | Service processor            | -P1                               |
| 0001       | 2                                  | 0                                           | Unused                       | -P1 (64 bit)                      |
| 0001       | 2                                  | 1                                           |                              |                                   |
| 0001       | 2                                  | 2                                           | Embedded Ethernet controller | -P1 (64 bit)                      |
| 0001       | 2                                  | 3                                           |                              |                                   |
| 0001       | 2                                  | 4                                           | Embedded Ethernet controller | -P1 (64 bit)                      |
| 0001       | 2                                  | 5                                           |                              |                                   |
| 0001       | 2                                  | 6                                           | Embedded SCSI controller     | -P1 (64 bit)                      |
| 0001       | 2                                  | 7                                           |                              |                                   |
| 0001       | 2                                  | F                                           | Multi-adapter bridge         | -P1                               |
| 0002       | 2                                  | 0                                           | PCI IOA card                 | -P1-C1 (64 bit)                   |
| 0002       | 2                                  | 1                                           |                              |                                   |
| 0002       | 2                                  | 2                                           | Unused                       | -P1 (64 bit)                      |
| 0002       | 2                                  | 3                                           |                              |                                   |
| 0002       | 2                                  | 4                                           | Unused                       | -P1 (64 bit)                      |
| 0002       | 2                                  | 5                                           |                              |                                   |
| 0002       | 2                                  | 6                                           | PCI IOA card                 | -P1-C2 (64 bit)                   |
| 0002       | 2                                  | 7                                           |                              |                                   |
| 0002       | 2                                  | F                                           | Multi-adapter bridge         | -P1                               |
| 0003       | 2                                  | 0                                           | PCI IOA card                 | -P1-C3 (64 bit)                   |
| 0003       | 2                                  | 1                                           |                              |                                   |
| 0003       | 2                                  | 2                                           | Unused                       | -P1 (64 bit)                      |
| 0003       | 2                                  | 3                                           |                              |                                   |
| 0003       | 2                                  | 4                                           | Unused                       | -P1 (64 bit)                      |
| 0003       | 2                                  | 5                                           |                              |                                   |
| 0003       | 2                                  | 6                                           | PCI IOA card                 | -P1-C4 (64 bit)                   |
| 0003       | 2                                  | 7                                           |                              |                                   |
| 0003       | 2                                  | F                                           | Multi-adapter bridge         | -P1                               |

Table 5. Card positions for 50/74, 50/79, 8079-002, and 8093-002 expansion units

| Bus number             | Multi-adapter bridge number in DSA | Multi-adapter bridge function number in DSA | Item DSA points to: | Position label and PCI data width |
|------------------------|------------------------------------|---------------------------------------------|---------------------|-----------------------------------|
| xxxx (assigned by LIC) | 1                                  | 0                                           | PCI IOP or IOA card | C01 (64 bit)                      |
| xxxx (assigned by LIC) | 1                                  | 2                                           | PCI IOP or IOA card | C02 (64 bit)                      |
| xxxx (assigned by LIC) | 1                                  | 4                                           | PCI IOP or IOA card | C03 (64 bit)                      |
| xxxx (assigned by LIC) | 1                                  | 6                                           | PCI IOP or IOA card | C04 (64 bit)                      |
| xxxx (assigned by LIC) | 1                                  | F                                           | PCI IOP or IOA card | CB1                               |

Service provider information

|                        |   |   |                      |                  |
|------------------------|---|---|----------------------|------------------|
| xxxx (assigned by LIC) | 1 | 0 | PCI IOP or IOA card  | C05 (64 bit/INS) |
| xxxx (assigned by LIC) | 1 | 2 | PCI IOP or IOA card  | C06 (32 bit)     |
| xxxx (assigned by LIC) | 1 | 3 | PCI IOP or IOA card  | C07 (32 bit)     |
| xxxx (assigned by LIC) | 1 | 4 | PCI IOP or IOA card  | C09 (64 bit)     |
| xxxx (assigned by LIC) | 1 | 6 | PCI IOP or IOA card  | C10 (64 bit)     |
| xxxx (assigned by LIC) | 1 | F | Multi-adapter bridge | CB1              |
| xxxx (assigned by LIC) | 2 | 0 | PCI IOP or IOA card  | C11 (64 bit/INS) |
| xxxx (assigned by LIC) | 2 | 2 | PCI IOP or IOA card  | C12 (32 bit)     |
| xxxx (assigned by LIC) | 2 | 3 | PCI IOP or IOA card  | C13 (32 bit)     |
| xxxx (assigned by LIC) | 2 | 4 | PCI IOP or IOA card  | C14 (64 bit)     |
| xxxx (assigned by LIC) | 2 | 6 | PCI IOP or IOA card  | C15 (64 bit)     |
| xxxx (assigned by LIC) | 2 | F | PCI IOP or IOA card  | CB1              |

Table 6. Card positions for 50/88, 05/88, 50/94, 52/94, and 8094-002 expansion units

| Bus number             | Multi-adapter bridge number in DSA | Multi-adapter bridge function number in DSA | Item DSA points to:  | Position label and PCI data width |
|------------------------|------------------------------------|---------------------------------------------|----------------------|-----------------------------------|
| xxxx (assigned by LIC) | 2                                  | 0 and 1                                     | PCI IOP or IOA card  | C01                               |
| xxxx (assigned by LIC) | 2                                  | 2 and 3                                     | PCI IOP or IOA card  | C02                               |
| xxxx (assigned by LIC) | 2                                  | 4 and 5                                     | PCI IOP or IOA card  | C03                               |
| xxxx (assigned by LIC) | 2                                  | 6 and 7                                     | IOA card             | C04                               |
| xxxx (assigned by LIC) | 2                                  | F                                           | Multi-adapter bridge | CB1                               |
| xxxx (assigned by LIC) | 2                                  | 0 and 1                                     | PCI IOP or IOA card  | C05                               |
| xxxx (assigned by LIC) | 2                                  | 2                                           | PCI IOP or IOA card  | C06                               |
| xxxx (assigned by LIC) | 2                                  | 3                                           | PCI IOP or IOA card  | C07                               |
| xxxx (assigned by LIC) | 2                                  | 4 and 5                                     | PCI IOP or IOA card  | C08                               |
| xxxx (assigned by LIC) | 2                                  | 6 and 7                                     | IOA card             | C09                               |
| xxxx (assigned by LIC) | 2                                  | F                                           | Multi-adapter bridge | CB1                               |
| xxxx (assigned by LIC) | 2                                  | 0 and 1                                     | PCI IOP or IOA card  | C11                               |
| xxxx (assigned by LIC) | 2                                  | 2                                           | PCI IOP or IOA card  | C12                               |
| xxxx (assigned by LIC) | 2                                  | 3                                           | PCI IOP or IOA card  | C13                               |
| xxxx (assigned by LIC) | 2                                  | 4 and 5                                     | PCI IOP or IOA card  | C14                               |
| xxxx (assigned by LIC) | 2                                  | 6 and 7                                     | IOA card             | C15                               |
| xxxx (assigned by LIC) | 2                                  | F                                           | Multi-adapter bridge | CB1                               |

Table 7. Card positions for 50/95, 05/95, and 11D/20 expansion units

| Bus number             | Multi-adapter bridge number in DSA | Multi-adapter bridge function number in DSA | Item DSA points to:  | Position label and PCI data width |
|------------------------|------------------------------------|---------------------------------------------|----------------------|-----------------------------------|
| xxxx (assigned by LIC) | 2                                  | 0 and 1                                     | PCI IOP              | C01                               |
| xxxx (assigned by LIC) | 2                                  | 2 and 3                                     | PCI IOP or IOA card  | C02                               |
| xxxx (assigned by LIC) | 2                                  | 4 and 5                                     | PCI IOP or IOA card  | C03                               |
| xxxx (assigned by LIC) | 2                                  | 6 and 7                                     | IOA card             | C04                               |
| xxxx (assigned by LIC) | 2                                  | F                                           | Multi-adapter bridge | CB1                               |
| xxxx (assigned by LIC) | 2                                  | Not used                                    | Not used             | C05                               |
| xxxx (assigned by LIC) | 2                                  | 0 and 1                                     | PCI IOP              | C06                               |
| xxxx (assigned by LIC) | 2                                  | 2 and 3                                     | PCI IOP or IOA card  | C07                               |
| xxxx (assigned by LIC) | 2                                  | 6 and 7                                     | IOA card             | C08                               |
| xxxx (assigned by LIC) | 2                                  | F                                           | Multi-adapter bridge | CB1                               |

Table 8. Card positions for 406/1D expansion unit

| Bus number in DSA (hexadecimal) | Multi-adapter bridge number in DSA | Multi-adapter bridge function number in DSA | Item DSA points to         | Position label and PCI data width |
|---------------------------------|------------------------------------|---------------------------------------------|----------------------------|-----------------------------------|
| LEFT SIDE I/O PLANAR (-P1)      |                                    |                                             |                            |                                   |
| Lower PCI bus number            | 2                                  | 0                                           | PCI IOA card               | -P1-I1 (64 bit)                   |
| Lower PCI bus number            | 2                                  | 1                                           |                            |                                   |
| Lower PCI bus number            | 2                                  | 2                                           | PCI IOA card               | -P1-I2 (64 bit)                   |
| Lower PCI bus number            | 2                                  | 3                                           |                            |                                   |
| Lower PCI bus number            | 2                                  | 4                                           | PCI IOA card               | -P1-I3 (64 bit)                   |
| Lower PCI bus number            | 2                                  | 5                                           |                            |                                   |
| Lower PCI bus number            | 2                                  | 6                                           | PCI IOA card               | -P1-I4 (64 bit)                   |
| Lower PCI bus number            | 2                                  | 7                                           |                            |                                   |
| Lower PCI bus number            | 2                                  | F                                           | Multi-adapter bridge       | -P1                               |
| Middle PCI bus number           | 2                                  | 0                                           | PCI IOA card               | -P1-I5 (64 bit)                   |
| Middle PCI bus number           | 2                                  | 1                                           |                            |                                   |
| Middle PCI bus number           | 2                                  | 2                                           | PCI IOA card               | -P1-I6 (64 bit)                   |
| Middle PCI bus number           | 2                                  | 3                                           |                            |                                   |
| Middle PCI bus number           | 2                                  | 4                                           | Embedded SCSI controller 1 | n/a                               |
| Middle PCI bus number           | 2                                  | 5                                           |                            |                                   |
| Middle PCI bus number           | 2                                  | 6                                           | PCI IOA card               | -P1-I7 (64 bit)                   |
| Middle PCI bus number           | 2                                  | 7                                           |                            |                                   |
| Middle PCI bus number           | 2                                  | F                                           | Multi-adapter bridge       | -P1                               |
| Higher PCI bus number           | 2                                  | 0                                           | PCI IOA card               | -P1-I8 (64 bit)                   |

Service provider information

|                             |   |   |                            |                  |
|-----------------------------|---|---|----------------------------|------------------|
| Higher PCI bus number       | 2 | 1 |                            |                  |
| Higher PCI bus number       | 2 | 2 | PCI IOA card               | -P1-I9 (64 bit)  |
| Higher PCI bus number       | 2 | 3 |                            |                  |
| Higher PCI bus number       | 2 | 4 | Embedded SCSI controller 2 | n/a              |
| Higher PCI bus number       | 2 | 5 |                            |                  |
| Higher PCI bus number       | 2 | 6 | PCI IOA card               | -P1-I10 (64 bit) |
| Higher PCI bus number       | 2 | 7 |                            |                  |
| Higher PCI bus number       | 2 | F | Multi-adapter bridge       | -P1              |
| RIGHT SIDE I/O PLANAR (-P2) |   |   |                            |                  |
| Lower PCI bus number        | 2 | 0 | PCI IOA card               | -P2-I1 (64 bit)  |
| Lower PCI bus number        | 2 | 1 |                            |                  |
| Lower PCI bus number        | 2 | 2 | PCI IOA card               | -P2-I2 (64 bit)  |
| Lower PCI bus number        | 2 | 3 |                            |                  |
| Lower PCI bus number        | 2 | 4 | PCI IOA card               | -P2-I3 (64 bit)  |
| Lower PCI bus number        | 2 | 5 |                            |                  |
| Lower PCI bus number        | 2 | 6 | PCI IOA card               | -P2-I4 (64 bit)  |
| Lower PCI bus number        | 2 | 7 |                            |                  |
| Lower PCI bus number        | 2 | F | Multi-adapter bridge       | -P2              |
| Middle PCI bus number       | 2 | 0 | PCI IOA card               | -P2-I5 (64 bit)  |
| Middle PCI bus number       | 2 | 1 |                            |                  |
| Middle PCI bus number       | 2 | 2 | PCI IOA card               | -P2-I6 (64 bit)  |
| Middle PCI bus number       | 2 | 3 |                            |                  |
| Middle PCI bus number       | 2 | 4 | Embedded SCSI controller 1 | n/a              |
| Middle PCI bus number       | 2 | 5 |                            |                  |
| Middle PCI bus number       | 2 | 6 | PCI IOA card               | -P2-I7 (64 bit)  |
| Middle PCI bus number       | 2 | 7 |                            |                  |
| Middle PCI bus number       | 2 | F | Multi-adapter bridge       | -P2              |
| Higher PCI bus number       | 2 | 0 | PCI IOA card               | -P2-I8 (64 bit)  |
| Higher PCI bus number       | 2 | 1 |                            |                  |
| Higher PCI bus number       | 2 | 2 | PCI IOA card               | -P2-I9 (64 bit)  |
| Higher PCI bus number       | 2 | 3 |                            |                  |
| Higher PCI bus number       | 2 | 4 | Embedded SCSI controller 2 | n/a              |
| Higher PCI bus number       | 2 | 5 |                            |                  |
| Higher PCI bus number       | 2 | 6 | PCI IOA card               | -P2-I10 (64 bit) |
| Higher PCI bus number       | 2 | 7 |                            |                  |
| Higher PCI bus number       | 2 | F | Multi-adapter bridge       | -P2              |

Table 9. Card positions for 11D/10, 11D/11, and 57/90 expansion units

| Bus number in DSA (hexadecimal) | Multi-adapter bridge number in DSA | Multi-adapter bridge function number in DSA | Item DSA points to | Position label and PCI data width |
|---------------------------------|------------------------------------|---------------------------------------------|--------------------|-----------------------------------|
| Lower PCI bus number            | 2                                  | 0                                           | PCI IOA card       | -P1-C1 (64 bit)                   |
| Lower PCI bus number            | 2                                  | 1                                           |                    |                                   |

Service provider information

|                       |   |   |                      |                 |
|-----------------------|---|---|----------------------|-----------------|
| Lower PCI bus number  | 2 | 2 | PCI IOA card         | -P1-C2 (64 bit) |
| Lower PCI bus number  | 2 | 3 |                      |                 |
| Lower PCI bus number  | 2 | 4 | Unused               | n/a             |
| Lower PCI bus number  | 2 | 5 |                      |                 |
| Lower PCI bus number  | 2 | 6 | PCI IOA card         | -P1-C3 (64 bit) |
| Lower PCI bus number  | 2 | 7 |                      |                 |
| Lower PCI bus number  | 2 | F | Multi-adapter bridge | -P1             |
| Higher PCI bus number | 2 | 0 | PCI IOA card         | -P1-C4 (64 bit) |
| Higher PCI bus number | 2 | 1 |                      |                 |
| Higher PCI bus number | 2 | 2 | PCI IOA card         | -P1-C5 (64 bit) |
| Higher PCI bus number | 2 | 3 |                      |                 |
| Higher PCI bus number | 2 | 4 | Unused               | n/a             |
| Higher PCI bus number | 2 | 5 |                      |                 |
| Higher PCI bus number | 2 | 6 | PCI IOA card         | -P1-C6 (64 bit) |
| Higher PCI bus number | 2 | 7 |                      |                 |
| Higher PCI bus number | 2 | F | Multi-adapter bridge | -P1             |

Parent topic: [Bus, high-speed link \(HSL or RIO\) isolation procedures](#)

## Converting the loop number to NIC port location labels

Use the following table to convert the HSL/RIO loop number to NIC port location labels.

**Note:** If you are working on an ESCALA PL 850R/PL 1650R/R+, exchange the FRU on the correct unit (primary or secondary) by matching the serial number (if available in the FRU list on the serviceable event view) or by matching the loop number to the correct unit.

**Note:** To simplify this information, secondary units on the ESCALA PL 850R/PL 1650R/R+ server are numbered 1 through 3-secondary unit 1 being nearest to the primary unit and secondary unit 3 being furthest.

Service provider information

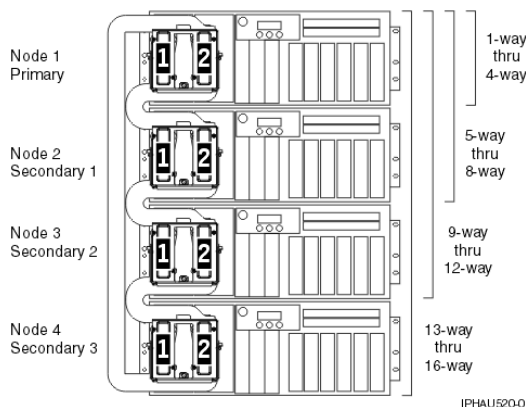


Table 1. Converting the loop number to NIC port location labels

| Loop number (hex / dec) | Model                                                        | NIC's FRU position | HSL port labels on system unit or processor tower                                                                            |
|-------------------------|--------------------------------------------------------------|--------------------|------------------------------------------------------------------------------------------------------------------------------|
| 0684 / 1668             | ESCALA PL 250T/R, ESCALA PL 450T/R, , 5/70primary unit, 5/75 | -P1                | Internal                                                                                                                     |
|                         | Node 0 on ESCALA PL 3250R or ESCALA PL 6450R                 | -P2                | Internal<br><br><b>Note:</b> The normal loop status is <i>OPEN</i> because the internal links are not joined to form a loop. |
| 0685 / 1669             | ESCALA PL 250T/R                                             | -P1                | -P1-T3-P1-T4                                                                                                                 |
|                         | ESCALA PL 450T/R, 7/20                                       | -P1                | -P1-T11-P1-T12                                                                                                               |
|                         | ESCALA PL 850R/PL 1650R/R+ primary unit                      | -P1                | -P1-T8-P1-T9                                                                                                                 |
|                         | 5/75                                                         | -P1                | -P1-T7-P1-T8                                                                                                                 |
|                         | Node 0 on ESCALA PL 3250R or ESCALA PL 6450R                 | -P2-C1             | -P2-C1-T1-P2-C1-T2                                                                                                           |
| 0686 / 1670             | ESCALA PL 450T/R, 7/20                                       | -P1-C6             | -P1-C6-T1-P1-C6-T2                                                                                                           |
|                         | ESCALA PL 850R/PL 1650R/R+ primary unit                      | -P1-C7             | -P1-C7-T1-P1-C7-T2                                                                                                           |
|                         | Node 0 on ESCALA PL 3250R or ESCALA PL 6450R                 | -P2                | Internal                                                                                                                     |
| 0687 / 1671             | ESCALA PL 850R/PL 1650R/R+ secondary unit 1                  | -P1                | Internal (see note above)                                                                                                    |
|                         | Node 0 on ESCALA PL 3250R or ESCALA PL 6450R                 | -P2-C3             | -P2-C3-T1-P2-C3-T2                                                                                                           |
| 0688 / 1672             | ESCALA PL 850R/PL 1650R/R+ secondary unit 1                  | -P1                | -P1-T8-P1-T9 (see note above)                                                                                                |
|                         | Node 0 on ESCALA PL 3250R or ESCALA PL 6450R                 | -P2-C5             | -P2-C5-T1-P2-C5-T2                                                                                                           |

Service provider information

|             |                                                    |         |                                                                                                                                       |
|-------------|----------------------------------------------------|---------|---------------------------------------------------------------------------------------------------------------------------------------|
| 0689 / 1673 | ESCALA PL 850R/PL<br>1650R/R+ secondary unit<br>1  | -P1-C7  | -P1-C7-T1-P1-C7-T2 (see<br>note above)                                                                                                |
| 068A / 1674 | ESCALA PL 850R/PL<br>1650R/R+ secondary unit<br>2  | -P1     | Internal (see note above)                                                                                                             |
|             | Node 0 on ESCALA PL<br>3250R or ESCALA PL<br>6450R | -P2-C6  | -P2-C6-T1-P2-C6-T2                                                                                                                    |
| 068B / 1675 | ESCALA PL 850R/PL<br>1650R/R+ secondary unit<br>2  | -P1     | -P1-T8-P1-T9 (see note<br>above)                                                                                                      |
| 068C / 1676 | ESCALA PL 850R/PL<br>1650R/R+ secondary unit<br>2  | -P1-C7  | -P1-C7-T1-P1-C7-T2(see<br>note above)                                                                                                 |
|             | Node 0 on ESCALA PL<br>3250R or ESCALA PL<br>6450R | -P2-C8  | -P2-C8-T1-P2-C8-T2                                                                                                                    |
| 068D / 1677 | ESCALA PL 850R/PL<br>1650R/R+ secondary unit<br>3  | -P1     | Internal (see note above)                                                                                                             |
| 068E / 1678 | ESCALA PL 850R/PL<br>1650R/R+ secondary unit<br>3  | -P1     | -P1-T8-P1-T9 (see note<br>above)                                                                                                      |
|             | Node 0 on ESCALA PL<br>3250R or ESCALA PL<br>6450R | -P2-C9  | -P2-C9-T1-P2-C9-T2                                                                                                                    |
| 068F / 1679 | ESCALA PL 850R/PL<br>1650R/R+ secondary unit<br>3  | -P1-C7  | -P1-C7-T1-P1-C7-T2 (see<br>note above)                                                                                                |
| 0690 / 1680 | Node 0 on ESCALA PL<br>3250R or ESCALA PL<br>6450R | -P2-C11 | -P2-C11-T1-P2-C11-T2                                                                                                                  |
| 0692 / 1682 | Node 0 on ESCALA PL<br>3250R or ESCALA PL<br>6450R | -P2-C13 | -P2-C13-T1-P2-C13-T2                                                                                                                  |
| 0694 / 1684 | Node 1 on ESCALA PL<br>3250R or ESCALA PL<br>6450R | -P3     | Internal<br><br><b>Note:</b> The normal loop<br>status is <i>OPEN</i> because<br>the internal links are not<br>joined to form a loop. |
| 0695 / 1685 | Node 1 on ESCALA PL<br>3250R or ESCALA PL<br>6450R | -P3-C1  | -P3-C1-T1-P3-C1-T2                                                                                                                    |
| 0696 / 1686 | Node 1 on ESCALA PL<br>3250R or ESCALA PL<br>6450R | -P3     | Internal                                                                                                                              |
| 0697 / 1687 | Node 1 on ESCALA PL<br>3250R or ESCALA PL<br>6450R | -P3-C3  | -P3-C3-T1-P3-C3-T2                                                                                                                    |
| 0698 / 1688 | Node 1 on ESCALA PL<br>3250R or ESCALA PL<br>6450R | -P3-C5  | -P3-C5-T1-P3-C5-T2                                                                                                                    |
| 069A / 1690 | Node 1 on ESCALA PL<br>3250R or ESCALA PL          | -P3-C6  | -P3-C6-T1-P3-C6-T2                                                                                                                    |

## Service provider information

|             |                                                    |         |                      |
|-------------|----------------------------------------------------|---------|----------------------|
|             | 6450R                                              |         |                      |
| 069C / 1692 | Node 1 on ESCALA PL<br>3250R or ESCALA PL<br>6450R | -P3-C8  | -P3-C8-T1-P3-C8-T2   |
| 069E / 1694 | Node 1 on ESCALA PL<br>3250R or ESCALA PL<br>6450R | -P3-C9  | -P3-C9-T1-P3-C9-T2   |
| 06A0 / 1696 | Node 1 on ESCALA PL<br>3250R or ESCALA PL<br>6450R | -P3-C11 | -P3-C11-T1-P3-C11-T2 |
| 06A2 / 1698 | Node 1 on ESCALA PL<br>3250R or ESCALA PL<br>6450R | -P3-C13 | -P3-C13-T1-P3-C13-T2 |
| 06A4 / 1700 | Node 2 on ESCALA PL<br>3250R or ESCALA PL<br>6450R | -P4-C1  | -P4-C1-T1-P4-C1-T2   |
| 06A6 / 1702 | Node 2 on ESCALA PL<br>3250R or ESCALA PL<br>6450R | -P4-C3  | -P4-C3-T1-P4-C3-T2   |
| 06A8 / 1704 | Node 2 on ESCALA PL<br>3250R or ESCALA PL<br>6450R | -P4-C5  | -P4-C5-T1-P4-C5-T2   |
| 06AA / 1706 | Node 2 on ESCALA PL<br>3250R or ESCALA PL<br>6450R | -P4-C6  | -P4-C6-T1-P4-C6-T2   |
| 06AC / 1708 | Node 2 on ESCALA PL<br>3250R or ESCALA PL<br>6450R | -P4-C8  | -P4-C8-T1-P4-C8-T2   |
| 06AE / 1710 | Node 2 on ESCALA PL<br>3250R or ESCALA PL<br>6450R | -P4-C9  | -P4-C9-T1-P4-C9-T2   |
| 06B0 / 1712 | Node 2 on ESCALA PL<br>3250R or ESCALA PL<br>6450R | -P4-C11 | -P4-C11-T1-P4-C11-T2 |
| 06B2 / 1714 | Node 2 on ESCALA PL<br>3250R or ESCALA PL<br>6450R | -P4-C13 | -P4-C13-T1-P4-C13-T2 |
| 06B4 / 1716 | Node 3 on ESCALA PL<br>3250R or ESCALA PL<br>6450R | -P5-C1  | -P5-C1-T1-P5-C1-T2   |
| 06B6 / 1718 | Node 3 on ESCALA PL<br>3250R or ESCALA PL<br>6450R | -P5-C3  | -P5-C3-T1-P5-C3-T2   |
| 06B8 / 1720 | Node 3 on ESCALA PL<br>3250R or ESCALA PL<br>6450R | -P5-C5  | -P5-C5-T1-P5-C5-T2   |
| 06BA / 1722 | Node 3 on ESCALA PL<br>3250R or ESCALA PL<br>6450R | -P5-C6  | -P5-C6-T1-P5-C6-T2   |
| 06BC / 1724 | Node 3 on ESCALA PL<br>3250R or ESCALA PL<br>6450R | -P5-C8  | -P5-C8-T1-P5-C8-T2   |
| 06BE / 1726 | Node 3 on ESCALA PL<br>3250R or ESCALA PL<br>6450R | -P5-C9  | -P5-C9-T1-P5-C9-T2   |
| 06C0 / 1728 | Node 3 on ESCALA PL<br>3250R or ESCALA PL<br>6450R | -P5-C11 | -P5-C11-T1-P5-C11-T2 |
| 06C2 / 1730 |                                                    | -P5-C13 | -P5-C13-T1-P5-C13-T2 |



|  |                                                    |  |  |
|--|----------------------------------------------------|--|--|
|  | Node 3 on ESCALA PL<br>3250R or ESCALA PL<br>6450R |  |  |
|--|----------------------------------------------------|--|--|

**Parent topic:** [Bus, high-speed link \(HSL or RIO\) isolation procedures](#)

---

## PCI bus isolation using AIX, Linux, or the HMC

Use this procedure if you are isolating a PCI bus problem from the HMC or while running AIX or Linux.

**Parent topic:** [Bus, high-speed link \(HSL or RIO\) isolation procedures](#)

**Isolating a PCI bus problem while running AIX or Linux**

Can the operating system be IPLed?

- No: Perform [MABIP52](#). This ends the procedure.
- Yes: Choose from the following:
  - ◆ If you are running AIX, go to [Running the online and stand-alone diagnostics](#) to isolate the PCI bus failure with online diagnostics in concurrent mode.
  - ◆ If you are running Linux, go to [Running the online and stand-alone diagnostics](#) to isolate the PCI bus failure with stand-alone diagnostics.
 This ends the procedure.

**Isolating a PCI bus problem from the HMC**

If you have locations for the FRUs given in the serviceable event view of the error log, use those locations and exchange:

1. Did the serviceable event view provide the location(s) for the failing FRU(s)?
  - ◆ Yes: Use those locations to exchange the given FRUs one at a time until the problem is resolved. This ends the procedure.
  - ◆ No: Continue with the next step.
2. Go to [DSA translation](#) to determine the Direct Select Address (DSA).
3. Perform the following:
  - a. Record the bus number value (BBBB) from the DSA and convert it to decimal format.
  - b. Search for the decimal system bus number in the partition resources screens on the HMC.
  - c. Record the frame or unit type and continue with the next step.
4. Record the CC value from the DSA. Is the CC value greater than 00?
  - ◆ Yes: Continue with the next step.
  - ◆ No: The multi-adapter bridge number and the multi-adapter function number have not been identified, and so the card slot cannot be identified using the DSA. Look in the HMC partition resources for non-reporting or non-operational hardware. That will indicate which cards in which positions need to be replaced. Refer to [Finding part locations](#) for the model you are working on for information about the multi-adapter bridge that controls those card slots. That multi-adapter bridge is also a FRU. This ends the procedure.
5. Is the right-most character (c) F?
  - ◆ No: Continue with the next step.
  - ◆ Yes: Only the multi-adapter bridge number has been identified. Record the multi-adapter bridge number (left-most character of CC) for later use. Since the card slot cannot be identified with the DSA, refer to [Finding part locations](#) for the model you are working on for information about the multi-adapter bridge that controls the card slots. Consider all card slots controlled by the multi-adapter bridge to be FRUs. This ends the procedure.
6. Refer to [Card positions](#) and use the BBBB and CC values that you recorded to identify the card position. Then return to the procedure that sent you here. This ends the procedure.

## Verifying a high-speed link, system PCI bus, or a multi-adapter bridge repair

Use this procedure to verify a repair for the high-speed link, a system PCI bus, or for a multi-adapter bridge.

Within this procedure, the terms "system" and "logical partition" are interchangeable when used individually.

1. Perform this procedure from the logical partition you were in when you were sent to this procedure, or from the HMC if this error was worked from the HMC.
2. If you previously powered off a system or logical partition, or an expansion unit during this service action, then you need to power it off again.
3. Install all cards, cables, and hardware, ensuring that all connections are tight. You can use the system configuration list to verify that the cards are installed correctly.
4. Power on any expansion unit, logical partition or system unit that was powered off during the service action. Is one of the following true?
  - ◆ If the system or a logical partition was powered off during the service action, does the IPL complete successfully to the IPL or does Install the System display?
  - ◆ If an expansion tower was powered off during the service action, does the expansion tower power on complete successfully?
  - ◆ If any IOP or IOA card locations were powered off using concurrent maintenance during the service action, do the slots power on successfully?
  - ◆ If you exchanged a FRU that should appear as a resource or resources to the system, such as an IOA, or I/O bridge, does the new FRU's resource appear in HSM as operational?
    - ◇ Yes: Continue with the next step.
    - ◇ No: Verify that you have followed the power off, remove and replace, and power-on procedures correctly. When you are sure that you have followed the procedures correctly, then exchange the next FRU in the list. If there are no more FRUs to exchange, then contact your next level of support. This ends the procedure.
5. Does the system or logical partition have mirrored protection? Select Yes if you are not sure.
  - ◆ No: Continue with the next step.
  - ◆ Yes: From the Dedicated Service Tools (DST) display, select Work with disk units, and resume mirrored protection for all units that have a suspended status.
6. Choose from the following options:
  - ◆ If you are working from a partition, from the Start a Service Tool display, select Hardware service manager and look for the I/O processors that have a failed or missing status.
  - ◆ If you are working from a HMC, look at the CEC properties.
    - a. Choose the I/O tab.
    - b. Look for IOAs or IOPs that have a failed or missing status.

Are all I/O processor cards operational?

**Note:** Ignore any IOPs that are listed with a status of not connected.

- ◆ Yes: Go to step [10](#).
  - ◆ No: Display the logical hardware resource information for the non-operational I/O processors. For all I/O processors and I/O adapters that are failing; record the bus number (BBBB), board (bb) and card information (Cc). Continue with the next step.
7. Perform the following:
    - a. Return to the Dedicated Service Tools (DST) display.
    - b. Display the Product Activity Log.
    - c. Select All logs and search for an entry with the same bus, board, and card address information as the non-operational I/O processor. Do not include informational or statistical entries in your search. Use only entries that occurred during the last IPL.

Did you find an entry for the SRC that sent you to this procedure?

    - ◇ No: Continue with the next step.
    - ◇ Yes: Ask your next level of support for assistance. This ends the procedure.
  8. Did you find a B600 6944 SRC that occurred during the last IPL?

- ◆ Yes: Continue with the next step.
  - ◆ No: A different SRC is associated with the non-operational I/O processor. Go to the [System reference code](#) list and look up the new SRC to correct the problem. This ends the procedure.
9. Is there a B600 xxxx SRC that occurred during the last IPL other than the B600 6944 and informational SRCs?
- ◆ Yes: Use the other B600 xxxx SRC to determine the problem. Go to the [System reference code](#) list and look up the new SRC to correct the problem. This ends the procedure.
  - ◆ No: You connected an I/O processor in the wrong card position. Use the system configuration list to compare the cards. When you have corrected the configuration, go to the start of this procedure to verify the bus repair. This ends the procedure.
10. If in a partition, use the hardware service manager function to print the system configuration list.
- Are there any configuration mismatches?
- ◆ No: Continue with the next step.
  - ◆ Yes: Ask your next level of support for assistance. This ends the procedure.
11. You have verified the repair of the system bus.
- a. If for this service action only an expansion unit was powered off or only the concurrent maintenance function was used for an IOP or IOA, then continue with the next step.
  - b. Otherwise, perform the following to return the system to the customer:
    - i. Power off the system or logical partition. See [Powering on and powering off](#) for details.
    - ii. Select the operating mode with which the customer was originally running.
    - iii. Power on the system or logical partition.
12. If the system has logical partitions and the entry point SRC was B600 xxxx, then check for related problems in other logical partitions that could have been caused by the failing part. This ends the procedure.

**Parent topic:** [Bus, high-speed link \(HSL or RIO\) isolation procedures](#)

## HSL loop configuration and status form

Use this HSL loop configuration and status form to record the status of the HSL ports in the loop.

**Note:** You may copy this form as necessary.

HSL loop configuration and status worksheet for system \_\_\_\_\_, Loop number \_\_\_\_\_

Table 1. HSL loop configuration and status form

| HSL resource information |               |          | Leading port information    |                                         | Trailing port information   |                                         |
|--------------------------|---------------|----------|-----------------------------|-----------------------------------------|-----------------------------|-----------------------------------------|
| Resource type            | Resource name | Frame ID | Port number (or "internal") | Link status ("operational" or "failed") | Port number (or "internal") | Link status ("operational" or "failed") |
|                          |               |          |                             |                                         |                             |                                         |
|                          |               |          |                             |                                         |                             |                                         |
|                          |               |          |                             |                                         |                             |                                         |
|                          |               |          |                             |                                         |                             |                                         |
|                          |               |          |                             |                                         |                             |                                         |
|                          |               |          |                             |                                         |                             |                                         |
|                          |               |          |                             |                                         |                             |                                         |
|                          |               |          |                             |                                         |                             |                                         |
|                          |               |          |                             |                                         |                             |                                         |
|                          |               |          |                             |                                         |                             |                                         |

|  |  |  |  |  |  |  |
|--|--|--|--|--|--|--|
|  |  |  |  |  |  |  |
|  |  |  |  |  |  |  |
|  |  |  |  |  |  |  |
|  |  |  |  |  |  |  |
|  |  |  |  |  |  |  |
|  |  |  |  |  |  |  |
|  |  |  |  |  |  |  |
|  |  |  |  |  |  |  |

Parent topic: [Forms](#)

---

## Forms

Provides various forms that may be needed during a service activity.

[Problem reporting forms](#)

[Work with electrostatic discharge-sensitive parts](#)

[Service log](#)

[HSL loop configuration and status form](#)

[Installed features in a PCI bridge set form](#)

[RIO/HSL link status diagnosis form](#)

[HSL cable location form](#)

- **Problem reporting forms**
- **Work with electrostatic discharge-sensitive parts**  
When holding or installing electrostatic discharge-sensitive (ESD) parts, use the ESD handling kit (IBM part 6428316) or similar. Read the instructions inside the top cover of the carrying case.
- **Service log**
- **HSL loop configuration and status form**  
Use this HSL loop configuration and status form to record the status of the HSL ports in the loop.
- **Installed features in a PCI bridge set form**  
Use this form to record the "PCI Bridge Set" card positions, and multi-adapter bridge function numbers.
- **RIO/HSL link status diagnosis form**  
Use this form to record the status of the RIO/HSL links.
- **HSL cable location form**  
Use this worksheet to determine the loop number, frame ID, and HSL port label for an HSL cable that you will be replacing. Record information in the table below when you are directed to do so.

Parent topic: [Reference information](#)

---

## Problem reporting forms

Use this form to record information displayed on the control panel or in the HMC when a problem occurs on the system.

Use one of the following forms, depending on whether you have a system in its manufacturing default configuration or a system with multiple logical partitions:

- [System in its manufacturing default configuration](#)
- [System with multiple logical partitions](#)

- **[Problem reporting form for a system in its manufacturing default configuration](#)**
- **[Problem reporting form for a system with multiple logical partitions](#)**

Collect as much of the following information as possible. For partitions, you must use the HMC to gather the information.

Parent topic: [Forms](#)

## Problem reporting form for a system in its manufacturing default configuration

Collect as much of the following information as possible. If necessary, you can use both the control panel and the HMC to gather the information.

| Required information                    | Your answers |
|-----------------------------------------|--------------|
| Date and time that the problem occurred |              |
| Describe the problem                    |              |
| Machine type                            |              |
| Model                                   |              |
| Serial number                           |              |
| Operating system, version, and release  |              |
| IPL type                                |              |
| IPL mode                                |              |
| Message ID                              |              |
| Message text                            |              |
| From/send program                       |              |
| Instruction number                      |              |
| To/receive program                      |              |
| Instruction number                      |              |
| Service request number (SRN)            |              |

Go to the HMC or the control panel and indicate whether the following lights are on:

| Control panel light | Place a check if light is on |
|---------------------|------------------------------|
| Power On            |                              |
| System Attention    |                              |
| Processor active    |                              |

Go to the HMC or control panel to find and record the values for functions 11 through 20. See [Collecting reference codes and system information](#) for step-by-step instructions on collecting reference codes. Use the following grid to record the characters shown on the HMC or Function/Data display.

|    |  |
|----|--|
| 11 |  |
|----|--|

Service provider information

|                                   |                                                        |
|-----------------------------------|--------------------------------------------------------|
| 12                                | -----                                                  |
| 13                                | -----                                                  |
| 14                                | -----                                                  |
| 15                                | -----                                                  |
| 16                                | -----                                                  |
| 17                                | -----                                                  |
| 18                                | -----                                                  |
| 19                                | -----                                                  |
| 20 (if you use the control panel) | -----                                                  |
| 20 (if you use the HMC)           | Machine type: Model: Processor feature code: IPL type: |

Parent topic: [Problem reporting forms](#)

## Problem reporting form for a system with multiple logical partitions

Collect as much of the following information as possible. For partitions, you must use the HMC to gather the information.

| Required information                                     | Your answers |
|----------------------------------------------------------|--------------|
| Date and time that the problem occurred                  |              |
| Describe the problem                                     |              |
| Machine type                                             |              |
| Model                                                    |              |
| Serial number                                            |              |
| Logical partition state                                  |              |
| Logical partition ID                                     |              |
| Logical partition operating system, version, and release |              |
| IPL type                                                 |              |
| IPL mode                                                 |              |
| Message ID                                               |              |
| Message text                                             |              |
| From/send program                                        |              |
| Instruction number                                       |              |
| To/receive program                                       |              |
| Instruction number                                       |              |
| Service request number (SRN)                             |              |

Go to the HMC or control panel and indicate whether the following lights are on:

| Control panel light | Place a check if light is on |
|---------------------|------------------------------|
| Power On            |                              |
| System Attention    |                              |
| Processor active    |                              |

Go to the HMC to find and record the values for functions 11 through 20. See [Collecting reference codes and system information](#) for step-by-step instructions on finding reference codes. Use the following grid to record the characters shown on the HMC.

|                                   |                                                                 |
|-----------------------------------|-----------------------------------------------------------------|
| 11                                | _____                                                           |
| 12                                | _____                                                           |
| 13                                | _____                                                           |
| 14                                | _____                                                           |
| 15                                | _____                                                           |
| 16                                | _____                                                           |
| 17                                | _____                                                           |
| 18                                | _____                                                           |
| 19                                | _____                                                           |
| 20 (if you use the control panel) | _____                                                           |
| 20 (if you use the HMC)           | Machine type:<br>Model:<br>Processor feature code:<br>IPL type: |

Parent topic: [Problem reporting forms](#)

## Work with electrostatic discharge-sensitive parts

When holding or installing electrostatic discharge-sensitive (ESD) parts, use the ESD handling kit (IBM part 6428316) or similar. Read the instructions inside the top cover of the carrying case.

All system logic cards are sensitive to electrostatic discharge. To prevent damage to ESD-sensitive logic cards, follow these instructions:

- Switch off power to the system or device before removing logic cards.
- Keep the ESD-sensitive card in the original shipping container until you install the card in the machine.
- When holding logic cards, move your body as little as possible to prevent an increase of static electricity from clothing fibers, carpet fibers, and furniture.
- Just before touching the ESD-sensitive card, discharge any static electricity in your body by touching the metal frame or cover of the machine. If possible, keep one hand on the frame when, for example,







**Note:** You may copy this form as necessary.

Table 1. HSL cable location form

| Loop number                          | From frame ID              | From HSL port label | To frame ID                | To HSL port label |
|--------------------------------------|----------------------------|---------------------|----------------------------|-------------------|
| Hexadecimal loop number _____        | Hexadecimal frame ID _____ |                     | Hexadecimal frame ID _____ |                   |
| Decimal loop number _____            | Decimal frame ID _____     |                     | Decimal frame ID _____     |                   |
| Cable type (optical or copper) _____ |                            |                     |                            |                   |

Parent topic: [Forms](#)

---

## Installed features in a PCI bridge set form

Use this form to record the "PCI Bridge Set" card positions, and multi-adapter bridge function numbers.

**Note:** You may copy this form as necessary.

Table 1. Installed features in a PCI bridge set

| PCI bridge set card positions | Multi-adapter bridge function number | Record if "IOP" or "IOA" is installed. |
|-------------------------------|--------------------------------------|----------------------------------------|
|                               | 0                                    |                                        |
|                               | 1                                    |                                        |
|                               | 2                                    |                                        |
|                               | 3                                    |                                        |
|                               | 4                                    |                                        |
|                               | 5                                    |                                        |
|                               | 6                                    |                                        |
|                               | 7                                    |                                        |

Parent topic: [Forms](#)

---

## RIO/HSL link status diagnosis form

Use this form to record the status of the RIO/HSL links.

|                            | Column A (starting status) |                                | Column B                       | Column C<br>(column A is <i>failed</i> and column B is <i>failed</i> ) | Column D                       | Column E<br>(column B is <i>failed</i> and column D is <i>failed</i> ) |
|----------------------------|----------------------------|--------------------------------|--------------------------------|------------------------------------------------------------------------|--------------------------------|------------------------------------------------------------------------|
| Resource with failing link | Port info                  | Port status                    | Port status                    |                                                                        | Port status                    |                                                                        |
| First                      | Frame ID<br>_____          | Port _0 (or internal)<br>_____ | Port _0 (or internal)<br>_____ |                                                                        | Port _0 (or internal)<br>_____ |                                                                        |
|                            | Card Position<br>_____     | Port _1 (or internal)<br>_____ | Port _1 (or internal)<br>_____ |                                                                        | Port _1 (or internal)<br>_____ |                                                                        |
|                            | Port #<br>_____            | _____                          | _____                          |                                                                        | _____                          |                                                                        |
| Second                     | Frame ID<br>_____          | Port _0 (or internal)<br>_____ | Port _0 (or internal)<br>_____ |                                                                        | Port _0 (or internal)<br>_____ |                                                                        |
|                            | Card Position<br>_____     | Port _1 (or internal)<br>_____ | Port _1 (or internal)<br>_____ |                                                                        | Port _1 (or internal)<br>_____ |                                                                        |
|                            | Port #<br>_____            | _____                          | _____                          |                                                                        | _____                          |                                                                        |

Parent topic: [Forms](#)

---

## Communication isolation procedure

This topic contains the procedure necessary to isolate a communications failure. Please read and observe the following warnings when using this procedure.

### **DANGER**When working on or around the system, observe the following precautions:

Electrical voltage and current from power, telephone, and communication cables are hazardous. To avoid a shock hazard:

- Connect power to this unit only with the provided power cord. Do not use the provided power cord for any other product.
- Do not open or service any power supply assembly.

- Do not connect or disconnect any cables or perform installation, maintenance, or reconfiguration of this product during an electrical storm.
- The product might be equipped with multiple power cords. To remove all hazardous voltages, disconnect all power cords.
- Connect all power cords to a properly wired and grounded electrical outlet. Ensure that the outlet supplies proper voltage and phase rotation according to the system rating plate.
- Connect any equipment that will be attached to this product to properly wired outlets.
- When possible, use one hand only to connect or disconnect signal cables.
- Never turn on any equipment when there is evidence of fire, water, or structural damage.
- Disconnect the attached power cords, telecommunications systems, networks, and modems before you open the device covers, unless instructed otherwise in the installation and configuration procedures.
- Connect and disconnect cables as described in the following procedures when installing, moving, or opening covers on this product or attached devices.

To Disconnect:

1. Turn off everything (unless instructed otherwise).
2. Remove the power cords from the outlets.
3. Remove the signal cables from the connectors.
4. Remove all cables from the devices

To Connect:

1. Turn off everything (unless instructed otherwise).
2. Attach all cables to the devices.
3. Attach the signal cables to the connectors.
4. Attach the power cords to the outlets.
5. Turn on the devices.

(D005)

- **COMIP01**

This procedure helps you to isolate problems with the communications input/output adapter (IOA) or input/output processor (IOP).

Parent topic: [Isolation procedures](#)

---

## Disk unit isolation procedure

This topic contains the procedure to isolate a failure in a disk unit.

Please read and observe all safety procedures before servicing the system and while performing the disk unit isolation procedure.

**Attention:** Unless instructed otherwise, always power off the system or expansion tower where the FRU is located, (see [Powering on and powering off](#)) before removing, exchanging, or installing a field-replaceable unit (FRU).

- **DSKIP03**

Use this procedure to determine the reference code, which is used to isolate a problem and to determine the failing device.

Parent topic: [Isolation procedures](#)

---

## DSKIP03

Use this procedure to determine the reference code, which is used to isolate a problem and to determine the failing device.

**Note:** When exchanging a disk unit, go to the [Disk unit recovery procedures](#).

1. If the system has logical partitions, perform this procedure from the logical partition that reported the problem. To determine if the system has logical partitions, go to [Determining if the system has logical partitions](#).
2. Look in the Service action log (see [The Service Action Log \(SAL\)](#)) for other errors logged at or around the same time as the 310x SRC. If no entries appear in the service action log, use the product activity log (see [Product activity log](#)). Use the other SRCs to correct the problem (see [List of system reference codes](#)) before performing an IPL. Contact your next level of support as necessary for assistance with SCSI bus problem isolation. If the problem is not corrected, continue with the next step.
3. Perform an IPL to dedicated service tool (DST). See [Dedicated Service Tools \(DST\)](#).

Does an SRC appear on the control panel?

- ◆ Yes: Go to step 6.
- ◆ No: Does either the Disk Configuration Error Report, the Disk Configuration Attention Report, or the Disk Configuration Warning Report display appear?
  - ◇ Yes: Continue with the next step.
  - ◇ No: Go to step 5.
- 4. Does one of the following messages appear in the list?
  - ◆ Missing disk units in the configuration
  - ◆ Missing mirror protection disk units in the configuration
  - ◆ Device parity protected units in exposed mode
    - ◇ No: Continue with the next step.
    - ◇ Yes: Select option 5, press F11, and then press Enter to display the details.

If all of the reference codes are 0000, go to [LICIP11](#) and use cause code 0002. If any of the reference codes are not 0000, go to step 6 and use the reference code that is not 0000.

**Note:** Use the characters in the *Type* column to find the correct reference code table.

5. Does the Display Failing System Bus display appear?
  - ◆ No: Look at all the Product activity logs by selecting Product activity log under DST (see [Dedicated Service Tools \(DST\)](#)). If there is more than one SRC logged, use an SRC that is logged against the IOP or IOA.
 

Is an SRC logged as a result of this IPL?

    - ◇ Yes: Continue with the next step.
    - ◇ No: You cannot continue isolating the problem. Use the original SRC and exchange the failing items, starting with the highest probable cause of failure. See the failing item list for this reference code in the [List of system reference codes](#). If the failing item list contains FI codes, see [Using failing item codes](#) to help determine part numbers and location in the system. This ends the procedure.
  - ◆ Yes: Use the reference code that is displayed under *Reference Code* to correct the problem. This ends the procedure.
6. Record the SRC on the Problem summary form (see [Problem reporting forms](#)).

Is the SRC the same one that sent you to this procedure?

- ◆ Yes: Continue with the next step.
  - ◆ No: Go to [Start of call procedure](#) to correct the problem. This ends the procedure.
7. Perform the following:
    - a. Power off the system or expansion tower. See [Powering on and powering off](#).
    - b. See [Using failing item codes](#) to find the devices identified by FI code FI01106.

- c. Disconnect one of the disk units, (other than the load-source disk unit), the tape units, or the optical storage units that are identified by FI code FI01106. Slide it partially out of the system.

**Note:** Do not disconnect the load-source disk unit, although FI code FI01106 may identify it.

8. Power on the system or the expansion tower that you powered off.

Does an SRC appear on the control panel?

- ◆ No: Continue with the next step.
- ◆ Yes: Go to step [12](#).

9. Does either the Disk Configuration Error Report, the Disk Configuration Attention Report, or the Disk Configuration Warning Report display appear with one of the following listed?

- ◆ Missing disk units in the configuration
- ◆ Missing mirror protection disk units in the configuration
- ◆ Device parity protected units in exposed mode
  - ◇ Yes: Continue with the next step.
  - ◇ No: Go to step [11](#).

10. Select option 5, press F11, and then press Enter to display details.

Does an SRC appear in the Reference Code column?

- ◆ No: Continue with the next step.
- ◆ Yes: Go to step [12](#).

11. Look at all the Product activity logs by selecting Product activity log under DST.

Is an SRC logged as a result of this IPL?

- ◆ Yes: Continue with the next step.
- ◆ No: The last device you disconnected is the failing item. Exchange the failing device and reconnect the devices that were disconnected previously.

**Note:** Before exchanging a disk drive, you should attempt to save customer data. See the [data recovery information](#).

This ends the procedure.

12. Record the SRC on the Problem summary form. See [Problem reporting forms](#).

Is the SRC the same one that sent you to this procedure?

- ◆ No: Continue with the next step.
- ◆ Yes: The last device you disconnected is not the failing item.
  - a. Leave the device disconnected and go to step [7](#) to continue isolation.
  - b. If you have disconnected all devices that are identified by FI code FI01106 except the load-source disk unit, reconnect all devices. Then, go to step [15](#).

13. Does the Disk Configuration Error Report, the Disk Configuration Attention Report, or the Disk Configuration Warning Report display appear with one of the following listed?

- ◆ Missing disk units in the configuration
- ◆ Missing mirror protection disk units in the configuration
- ◆ Device parity protected units in exposed mode
  - ◇ Yes: Continue with the next step.
  - ◇ No: Use the reference code to correct the problem. This ends the procedure.

14. Select option 5, press F11, and then press Enter to display details.

Are all the reference codes 0000?

- ◆ No: Use the reference code to correct the problem. This ends the procedure.
- ◆ Yes: The last device you disconnected is the failing item.
  - a. Reconnect all devices except the failing item.

- b. Before exchanging a disk unit, go to the disk unit go to the [Removing and replacing parts](#) for the model you are working on. This ends the procedure.
15. Was disk unit 1 (the load-source disk unit) a failing item that FI code FI01106 identified?
- ◆ Yes: The failing items that FI code FI01106 identified are not failing. The load-source disk unit may be failing. Use the original SRC and exchange the failing items, starting with the highest probable cause of failure (see the failing item list for this reference code in the [List of system reference codes](#). If the failing item list contains FI codes, see [Using failing item codes](#) to help determine part numbers and location in the system. This ends the procedure.
  - ◆ No: The failing items that FI code FI01106 identified are not failing. Use the original SRC and exchange the failing items, starting with the highest probable cause of failure. See the failing item list for this reference code in the [List of system reference codes](#). If the failing item list contains FI codes, see [Using failing item codes](#) to help determine part numbers and location in the system. This ends the procedure.

Parent topic: [Disk unit isolation procedure](#)

---

## High performance switch (HPS) isolation procedures

Contains the procedures necessary to isolate a high performance switch (HPS) failure.

Please read and observe the following warnings when using these procedures.

### **DANGER**When working on or around the system, observe the following precautions:

Electrical voltage and current from power, telephone, and communication cables are hazardous. To avoid a shock hazard:

- Connect power to this unit only with the provided power cord. Do not use the provided power cord for any other product.
- Do not open or service any power supply assembly.
- Do not connect or disconnect any cables or perform installation, maintenance, or reconfiguration of this product during an electrical storm.
- The product might be equipped with multiple power cords. To remove all hazardous voltages, disconnect all power cords.
- Connect all power cords to a properly wired and grounded electrical outlet. Ensure that the outlet supplies proper voltage and phase rotation according to the system rating plate.
- Connect any equipment that will be attached to this product to properly wired outlets.
- When possible, use one hand only to connect or disconnect signal cables.
- Never turn on any equipment when there is evidence of fire, water, or structural damage.
- Disconnect the attached power cords, telecommunications systems, networks, and modems before you open the device covers, unless instructed otherwise in the installation and configuration procedures.
- Connect and disconnect cables as described in the following procedures when installing, moving, or opening covers on this product or attached devices.

To Disconnect:

1. Turn off everything (unless instructed otherwise).
2. Remove the power cords from the outlets.
3. Remove the signal cables from the connectors.
4. Remove all cables from the devices

To Connect:

1. Turn off everything (unless instructed otherwise).
2. Attach all cables to the devices.
3. Attach the signal cables to the connectors.
4. Attach the power cords to the outlets.
5. Turn on the devices.

(D005)

These procedures will help you isolate problems with a high performance switch.

- **HPS0000**  
Use this procedure to isolate high performance switch (HPS) network device problems.
- **HPSA001**  
Use this procedure to isolate High Performance Switch SNI reported faults.
- **HPSB001**  
Use this procedure to isolate power subsystem problems reported through the HPS Network Management path.
- **HPSS001**  
Use this procedure to isolate High Performance Switch-reported faults.

Parent topic: [Isolation procedures](#)

---

## HPS0000

Use this procedure to isolate high performance switch (HPS) network device problems.

1. Have you been directed here because you are isolating a Serviceable Event reported in Service Focal Point?
  - ◆ **No:** Go to step 3.
  - ◆ **Yes:** Continue with step 2.
2. **Service Focal Point isolation:** If you have come to this procedure while trying to repair a Serviceable Event presented in Service Focal Point, perform the following actions:
  - a. From Service Focal Point, record the 8 digit reference code that begins with BB.
  - b. Look up the recorded reference code and follow the procedure in Appendix A, section "BBXXXXXX FRU identification codes" in the [45H/W4 Switch Planning, Installation, and Service for POWER5 technology based servers](#) manual.
  - c. After you have fixed the problem, be sure that you provide comments and information regarding FRU replacements for the Serviceable Event in Service Focal Point before you close it. **This ends the procedure.**
3. **Non-Service Focal Point isolation:** If you have come to this procedure while trying to isolate a problem that was reported outside of Service Focal Point, perform the following actions:
  - a. Follow the procedure in Chapter 7. Maintenance Analysis Procedures (MAPs) in the [45H/W4 Switch Planning, Installation, and Service for POWER5 technology based servers](#) manual. **This ends the procedure.**
  - b. Follow the procedures for Starting a Service Call in the [45H/W4 Switch Planning, Installation, and Service for POWER5 technology based servers](#) manual. **This ends the procedure.**

Parent topic: [High performance switch \(HPS\) isolation procedures](#)

---

## HPSA001

Use this procedure to isolate High Performance Switch SNI reported faults.

1. From Service Focal Point, record the 8 digit reference code that begins with BB.
2. Look up the recorded reference code and follow the procedure in Appendix A, section "BBXXXXXX FRU identification codes" in the [45H/W4 Switch Planning, Installation, and Service for POWER5 technology based servers](#) manual. **This ends the procedure.**

Parent topic: [High performance switch \(HPS\) isolation procedures](#)

---

## HPSB001

Use this procedure to isolate power subsystem problems reported through the HPS Network Management path.

1. Does the 8 digit reference code begin with 101F?
  - ◆ **Yes:** Refer to Appendix A, section "101FXXXX FRU identification codes" in the [45H/W4 Switch Planning, Installation, and Service for POWER5 technology based servers](#) manual. **This ends the procedure.**
  - ◆ **No:** Go to 2.
2. Does the 8 digit reference code begin with 101A or 101B?



- ◆ **Yes:** Go to MAP 1520 Power in the *45H/W4 Switch Planning, Installation, and Service for POWER5 technology based servers* manual. **This ends the procedure.**
- ◆ **No:** Go to Starting a Service Call in the *45H/W4 Switch Planning, Installation, and Service for POWER5 technology based servers* manual. **This ends the procedure.**

**Parent topic:** [High performance switch \(HPS\) isolation procedures](#)

---

## HPSS001

Use this procedure to isolate High Performance Switch-reported faults.

1. From Service Focal Point, record the 8 digit reference code that begins with BB.
2. Look up the recorded reference code and follow the *45H/W4 Switch Planning, Installation, and Service for POWER5 technology based servers* manual. **This ends the procedure.**

**Parent topic:** [High performance switch \(HPS\) isolation procedures](#)

---

## Intermittent isolation procedures

These procedures help you to correct an intermittent problem.

### **DANGER**When working on or around the system, observe the following precautions:

Electrical voltage and current from power, telephone, and communication cables are hazardous. To avoid a shock hazard:

- Connect power to this unit only with the provided power cord. Do not use the provided power cord for any other product.
- Do not open or service any power supply assembly.
- Do not connect or disconnect any cables or perform installation, maintenance, or reconfiguration of this product during an electrical storm.
- The product might be equipped with multiple power cords. To remove all hazardous voltages, disconnect all power cords.
- Connect all power cords to a properly wired and grounded electrical outlet. Ensure that the outlet supplies proper voltage and phase rotation according to the system rating plate.
- Connect any equipment that will be attached to this product to properly wired outlets.
- When possible, use one hand only to connect or disconnect signal cables.
- Never turn on any equipment when there is evidence of fire, water, or structural damage.
- Disconnect the attached power cords, telecommunications systems, networks, and modems before you open the device covers, unless instructed otherwise in the installation and configuration procedures.
- Connect and disconnect cables as described in the following procedures when installing, moving, or opening covers on this product or attached devices.
  - To Disconnect:
    1. Turn off everything (unless instructed otherwise).
    2. Remove the power cords from the outlets.
    3. Remove the signal cables from the connectors.
    4. Remove all cables from the devices

To Connect:

1. Turn off everything (unless instructed otherwise).
2. Attach all cables to the devices.
3. Attach the signal cables to the connectors.
4. Attach the power cords to the outlets.
5. Turn on the devices.

(D005)

Use these procedures to correct an intermittent problem, if other problem analysis steps or tables sent you here. Only perform the procedures that apply to your system.

Read all safety procedures before servicing the system. Observe all safety procedures when performing a procedure. Unless instructed otherwise, always power off the system or expansion unit where the FRU is located. See [Powering on and powering off](#) before removing, exchanging, or installing a field-replaceable unit (FRU).

Use the procedure below to identify intermittent problems and the associated corrective actions.

- **INTIP03**  
Use this procedure to isolate problems with external noise on AC voltage lines.
- **INTIP05**  
Use this procedure to isolate problems with external noise on twinaxial cables.
- **INTIP07**  
Use this procedure to lessen the effects of electrical noise (electromagnetic interference, or EMI) on the system.
- **INTIP08**  
Use this procedure to ensure that the system is electrically grounded correctly.
- **INTIP09**  
Use this procedure to check the AC electrical power for the system.
- **INTIP14**  
Use this procedure to isolate problems with station protectors.
- **INTIP16**  
Use this procedure when you need to copy a main storage dump to give to your next level of support.
- **INTIP18**  
Use this procedure to determine if one or more PTFs are available to correct this specific problem.
- **INTIP20**  
Use this procedure to analyze system performance problems.
- **INTIP24**  
Use this procedure to collect data when the service processor reports a suspected intermittent problem.

Parent topic: [Isolation procedures](#)

---

## INTIP03

Use this procedure to isolate problems with external noise on AC voltage lines.

### **DANGER**When working on or around the system, observe the following precautions:

Electrical voltage and current from power, telephone, and communication cables are hazardous. To avoid a shock hazard:

- Connect power to this unit only with the provided power cord. Do not use the provided power cord for any other product.
- Do not open or service any power supply assembly.
- Do not connect or disconnect any cables or perform installation, maintenance, or reconfiguration of this product during an electrical storm.
- The product might be equipped with multiple power cords. To remove all hazardous voltages, disconnect all power cords.
- Connect all power cords to a properly wired and grounded electrical outlet. Ensure that the outlet supplies proper voltage and phase rotation according to the system rating plate.
- Connect any equipment that will be attached to this product to properly wired outlets.
- When possible, use one hand only to connect or disconnect signal cables.
- Never turn on any equipment when there is evidence of fire, water, or structural damage.
- Disconnect the attached power cords, telecommunications systems, networks, and modems before you open the device covers, unless instructed otherwise in the installation and configuration procedures.
- Connect and disconnect cables as described in the following procedures when installing, moving, or opening covers on this product or attached devices.  
To Disconnect:
  1. Turn off everything (unless instructed otherwise).
  2. Remove the power cords from the outlets.

3. Remove the signal cables from the connectors.
4. Remove all cables from the devices

To Connect:

1. Turn off everything (unless instructed otherwise).
2. Attach all cables to the devices.
3. Attach the signal cables to the connectors.
4. Attach the power cords to the outlets.
5. Turn on the devices.

(D005)

Electrical noise on incoming ac voltage lines can cause various system failures. The most common source of electrical noise is lightning.

1. Ask the customer if an electrical storm was occurring at the time of the failure to determine if lightning could have caused the failure.

Could lightning have caused the failure?

- ◆ **No:** Go to step 3.
- ◆ **Yes:** Continue with the next step.

2. Determine if lightning protection devices are installed on the incoming ac voltage lines where they enter the building. There must be a dedicated ground wire from the lightning protection devices to earth ground.

Are lightning protection devices installed?

- ◆ **Yes:** Continue with the next step.
- ◆ **No:** Lightning may have caused the intermittent problem. Recommend that the customer install lightning protection devices to prevent this problem from recurring. **This ends the procedure.**

3. Have an installation planning representative perform the following:
  - a. Connect a recording ac voltage monitor to the incoming ac voltage lines of the units that contain the failing devices with reference to ground.
  - b. Set the voltage monitor to start recording at a voltage slightly higher than the normal incoming ac voltage.

Does the system fail again with the same symptoms?

- ◆ **No: This ends the procedure.**
  - ◆ **Yes:** Continue with the next step.
4. Look at the recording and see if the voltage monitor recorded any noise when the failure occurred. Did the monitor record any noise when the failure occurred?
    - ◆ **Yes:** Review with the customer what was happening external to the system when the failure occurred. This may help you to determine the source of the noise. Discuss with the customer what to do to remove the noise or to prevent it from affecting the server. **This ends the procedure.**
    - ◆ **No:** Perform the next intermittent isolation procedure listed in the *Isolation procedure* column. **This ends the procedure.**

Parent topic: [Intermittent isolation procedures](#)

---

## INTIP08

Use this procedure to ensure that the system is electrically grounded correctly.

1. Have an **installation planning representative** or an electrician (when necessary), perform the following steps.
2. Power off the server and the power network branch circuits before performing this procedure.
3. Ensure the safety of personnel by making sure that all electrical wiring in the United States meets National Electrical Code requirements.

4. Check *all* system receptacles to ensure that each one is wired correctly. This includes receptacles for the server and all equipment that attaches to the server, including workstations. Do this to determine if a wire with primary voltage on it is swapped with the ground wire, causing an electrical shock hazard.
5. For each unit, check continuity from a conductive area on the frame to the ground pin on the plug. Do this at the end of the mainline ac power cable. The resistance must be 0.1 ohm or less.
6. Ground continuity must be present from each unit receptacle to an effective ground. Therefore, check the following:
  - ◆ The ac voltage receptacle for each unit must have a ground wire connected from the ground terminal on the receptacle to the ground bar in the power panel.
  - ◆ The ground bars in all branch circuit panels must be connected with an insulated ground wire to a **ground point**, which is defined as follows:
    - ◇ The nearest available metal cold water pipe, only if the pipe is effectively grounded to the earth (see *National Electric Code* Section 250-81, in the United States).
    - ◇ The nearest available steel beams in the building structure, only if the beam is effectively grounded to the earth.
    - ◇ Steel bars in the base of the building or a metal ground ring that is around the building under the surface of the earth.
    - ◇ A ground rod in the earth (see *National Electric Code* Section 250-83, in the United States).

**Note:** For installations in the United States only, by National Electrical Code standard, if more than one of the preceding grounding methods are used, they must be connected together electrically. See *National Electric Code* Section 250, for more information on grounding.

- ◆ The grounds of all separately derived sources (uninterruptable power supply, service entrance transformer, system power module, motor generator) must be connected to a **ground point** as defined above.
- ◆ The service entrance ground bar must connect to a **ground point** as defined above.
- ◆ All ground connections **must be tight**.
- ◆ Check continuity of the ground path for each unit that is using an ECOS tester, Model 1023-100. Check continuity at each unit receptacle, and measure to the **ground point** as defined above. The total resistance of each ground path must be 1.0 ohm or less. If you cannot meet this requirement, check for faults in the ground path.
- ◆ Conduit is sometimes used to meet wiring code requirements. If conduit is used, the branch circuits must still have a green (or green and yellow) wire for grounding as stated above.

**Note:** The ground bar and the neutral bar must never be connected together in branch circuit power panels.

The ground bar and the neutral bar in the power panels that make up the electrical power network for the server must be connected together. This applies to the first electrically isolating unit that is found in the path of electrical wiring from the server to the service entrance power panel. This isolating unit is sometimes referred to as a **separately derived source**. It can be an uninterruptable power supply, the system power module for the system, or the service entrance transformer. If the building has none of the above isolating units, the ground bar and the neutral bar must be connected together in the service entrance power panel.

7. Look inside all power panels to ensure the following:
  - ◆ There is a separate ground wire for each unit.
  - ◆ The green (or green and yellow) ground wires are connected only to the ground bar.
  - ◆ The ground bar inside each power panel is connected to the frame of the panel.
  - ◆ The neutral wires are connected only to the neutral bar.
  - ◆ The ground bar and the neutral bar are not connected together, except as stated in step 6.
8. For systems with more than one unit, ensure that the ground wire for each unit is not connected from one receptacle to the next in a string. Each unit must have its own ground wire, which goes to the power source.
9. Ensure that the grounding wires are insulated with green (or green and yellow) wire at least equal in size to the phase wires. The grounding wires also should be as short as possible.
10. If extension-mainline power cables or multiple-outlet power strips are used, make sure that they must have a three-wire cable. One of the wires must be a ground conductor. The ground connector on the plug must not be removed. This applies to any extension mainline power cables or multiple-outlet

power strips that are used on the server. It also applies for attaching devices such as personal computers, workstations, and modems.

**Note:** Check all extension-mainline power cables and multiple-outlet power strips with an ECOS tester and with power that is applied. Ensure that no wires are crossed (for example, a ground wire crossed with a wire that has voltage on it).

11. For more information on grounding, see [Power quality](#) in the [Planning](#) topic. **This ends the procedure.**

Parent topic: [Intermittent isolation procedures](#)

---

## INTIP24

Use this procedure to collect data when the service processor reports a suspected intermittent problem.

It is important that you collect data for this problem so that the problem can be corrected. Use this procedure to collect the data.

There are several ways the system can display the SRC. Follow the instructions for the correct display method, defined as follows:

- If this SRC is displayed in the Product Activity Log (PAL) or ASM log, then record all of the SRC data words, save all of the error log data, and contact your next level of support to submit an APAR.
- If the control panel is displaying SRC data words scrolling automatically through control panel functions 11, 12 and 13, and the control panel user interface buttons are not responding, then perform [FSPSP02](#) instead of using this procedure.
- If the SRC is displayed at the control panel, and the control panel user interface buttons respond normally, then record all of the SRC words.

Do not perform an IPL until you perform a storage dump of the service processor. To get a storage dump of the service processor, perform the following:

1. Record the complete system reference code (SRC) (functions 11 through 20) on the [Problem reporting forms](#).
2. Perform a service processor dump. See [Performing a main storage or platform dump](#) in the [Troubleshooting](#) topic.
3. Is a display shown on the console?
  - ◆ **Yes:** Continue with the next step.
  - ◆ **No:** The problem is not intermittent. Choose from the following options:
    - ◇ If you were sent here from [Reference codes](#), return there and follow the procedure for a problem that is not intermittent.
    - ◇ If the problem continues, replace the service processor hardware. See symbolic FRU [SVCPROC](#). **This ends the procedure.**
4. The problem is intermittent. Copy the IOP dump to tape. See [Performing a main storage or platform dump](#) in the [Troubleshooting](#) topic.
5. Complete the IPL.
6. Go to the [General intermittent problem checklist](#) to find available program temporary fixes (PTFs) for this problem.
7. If you need to apply a PTF, see [Getting fixes](#) in the Customer Service and support information. Then, return here and answer the following question.

Did you find and apply a PTF for this problem?

- ◆ **Yes: This ends the procedure.**
- ◆ **No:** Record the following information, and contact your next level of support.
  - ◇ The complete SRC you recorded in this procedure
  - ◇ The service processor dump to tape you obtained in step 4.

- ◇ All known system symptoms:
  - How often the intermittent problem occurs
  - System environment (IPL, certain applications)
  - If necessary, other SRCs that you suspect relate to the problem
- ◇ Information needed to write an LICTR. See [Authorized Program Analysis Report \(APAR\)](#). **This ends the procedure.**

Parent topic: [Intermittent isolation procedures](#)

---

## I/O processor (IOP) isolation procedures

Use these procedures to isolate a failure in the multiple function I/O card.

Please read all safety procedures before servicing the system.

**Attention:** Unless instructed otherwise, always power off the system or expansion tower where the field replaceable unit (FRU) is located (see [Powering on and powering off](#)) before removing, exchanging, or installing a FRU.

**Attention:** Disconnecting the J15 and J16 cables will not prevent the system unit from powering on.

### **DANGER**When working on or around the system, observe the following precautions:

Electrical voltage and current from power, telephone, and communication cables are hazardous. To avoid a shock hazard:

- Connect power to this unit only with the provided power cord. Do not use the provided power cord for any other product.
- Do not open or service any power supply assembly.
- Do not connect or disconnect any cables or perform installation, maintenance, or reconfiguration of this product during an electrical storm.
- The product might be equipped with multiple power cords. To remove all hazardous voltages, disconnect all power cords.
- Connect all power cords to a properly wired and grounded electrical outlet. Ensure that the outlet supplies proper voltage and phase rotation according to the system rating plate.
- Connect any equipment that will be attached to this product to properly wired outlets.
- When possible, use one hand only to connect or disconnect signal cables.
- Never turn on any equipment when there is evidence of fire, water, or structural damage.
- Disconnect the attached power cords, telecommunications systems, networks, and modems before you open the device covers, unless instructed otherwise in the installation and configuration procedures.
- Connect and disconnect cables as described in the following procedures when installing, moving, or opening covers on this product or attached devices.
  - To Disconnect:
    1. Turn off everything (unless instructed otherwise).
    2. Remove the power cords from the outlets.
    3. Remove the signal cables from the connectors.
    4. Remove all cables from the devices

To Connect:

1. Turn off everything (unless instructed otherwise).
2. Attach all cables to the devices.
3. Attach the signal cables to the connectors.

4. Attach the power cords to the outlets.

5. Turn on the devices.

(D005)

- **IOPIP01**  
Use this procedure to perform an IPL to dedicated service tool (DST) to determine if the same reference code occurs.
- **IOPIP13**  
Use this procedure to isolate problems on the interface between the I/O card and the storage devices.
- **IOPIP16**  
Use this procedure to isolate failing devices that are identified by FI codes FI01105, FI01106, and FI01107.
- **IOPIP17**  
Use this procedure to isolate problems that are associated with SCSI bus configuration errors and device task initialization failures.
- **IOPIP18**  
Use this procedure to isolate problems that are associated with SCSI bus configuration errors and device task initialization failures.
- **IOPIP19**  
You were sent to this procedure from unit reference code (URC) 9010, 9011, or 9013.
- **IOPIP20**  
Use this procedure to isolate the problem when two or more devices are missing from a disk array.
- **IOPIP21**  
Use this procedure to determine the failing disk unit when, a disk unit is not compatible with other disk units in the disk array, or when a disk unit has failed. If the URC is 9025 or 9030, the disk array is running, but it might not be protected.
- **IOPIP22**  
Use this procedure to gather error information and contact your next level of support.
- **IOPIP23**  
You were sent to this procedure from a unit reference code (URC) 9050.
- **IOPIP25**  
Use this procedure to isolate the problem when a device attached to the I/O card has functions that are not given support on the I/O card.
- **IOPIP26**  
Use this procedure to correct the problem when the I/O card recognizes that the attached disk unit must be initialized and formatted.
- **IOPIP27**  
I/O card cache data exists for a missing or failed device.
- **IOPIP28**  
You were sent to this procedure from unit reference code (URC) 9052.
- **IOPIP29**  
The failing item is in a migrated tower.
- **IOPIP30**  
Use this procedure to correct the problem when the system cannot find the required cache data for the attached disk units.
- **IOPIP31**  
Cache data associated with the attached devices cannot be found.
- **IOPIP32**  
You were sent to this procedure from unit reference code (URC) 9011.
- **IOPIP33**  
The I/O processor card detected a device configuration error. The configuration sectors on the device may be incompatible with the current I/O processor card.
- **IOPIP34**  
You were sent to this procedure from unit reference code (URC) 9027.
- **IOPIP40**  
Use this procedure to isolate the problem when a storage I/O adapter is connected to an incompatible or non-operational auxiliary cache I/O adapter.
- **IOPIP41**  
Use this procedure to correct the problem when an auxiliary cache I/O adapter is not connected to a storage I/O adapter or when an auxiliary cache I/O adapter is connected to an incompatible or non-operational storage I/O adapter.

**Parent topic:** [Isolation procedures](#)

---

## IOPIP01

Use this procedure to perform an IPL to dedicated service tool (DST) to determine if the same reference code occurs.

If a new reference code occurs, more analysis may be possible with the new reference code. If the same reference code occurs, you are instructed to exchange the failing items.

1. If the system has logical partitions, perform this procedure from the logical partition that reported the problem. To determine if the system has logical partitions, go to [Determining if the system has logical partitions](#), before continuing with this procedure.
2. Was the IPL performed from disk (Type A or Type B)?
  - ◆ No: Continue with the next step.
  - ◆ Yes: Go to step 5.
3. Perform the following:
  - a. Ensure that the IPL media is the correct version and level that are needed for the system model.
  - b. Ensure that the media is not physically damaged.
  - c. Choose from the following options to clean the IPL media:
    - ◇ If it is cartridge type optical media (for example, DVD), do not attempt to clean the media.
    - ◇ If it is non-cartridge type media (for example, CD-ROM), wipe the disc in a straight line from the inner hub to the outer rim. Use a soft, lint-free cloth or lens tissue. Always handle the disc by the edges to avoid finger prints.
    - ◇ If it is tape, clean the recording head in the tape unit. Use the correct Cleaning Cartridge Kit provided by your service provider.
4. Perform a Type D IPL in Manual mode.

Does a system reference code (SRC) appear on the control panel?

- ◆ No: Go to step 8.
  - ◆ Yes: Is the SRC the same one that sent you to this procedure?
    - ◇ Yes: You cannot continue isolating the problem. Use the original SRC and exchange the failing items, starting with the highest probable cause of failure. Refer to the failing item column in the reference code list. See [Reference codes](#) for details. If the failing item list contains FI codes, see [Using failing item codes](#) to help determine part numbers and location in the system. This ends the procedure.
    - ◇ No: A different SRC occurred. Use the new SRC to correct the problem. See [Start of call procedure](#). This ends the procedure.
5. Perform an IPL to DST. See [Performing an IPL to DST](#).

Does an SRC appear on the control panel?

- ◆ No: Continue with the next step.
  - ◆ Yes: Go to step 10.
6. Does either the Disk Configuration Error Report, the Disk Configuration Attention Report, or the Disk Configuration Warning Report display appear on the console?
- ◆ No: Continue with the next step.
  - ◆ Yes: Select option 5, press F11, then press Enter to display the details. Then, choose from the following options:
    - ◇ If all of the reference codes are 0000, go to [LICIP11](#) and use cause code 0002.
    - ◇ If any of the reference codes are not 0000, go to step 10, and use the reference code that is not 0000.

**Note:** Use the characters in the *Type* column to find the correct reference code table.

7. Look at the product activity log. See [Using the product activity log](#) for details.

Is an SRC logged as a result of this IPL?



- ◆ Yes: Continue with the next step.
  - ◆ No: The problem cannot be isolated any more. Use the original SRC and exchange the failing items. Start with the highest probable cause of failure in the failing item list for this reference code in the [Reference codes](#) topic and [Removing and replacing parts](#). If the failing item list contains FI codes, see [Using failing item codes](#) to help determine part numbers and location in the system. This ends the procedure.
8. Does either the Disk Configuration Error Report, the Disk Configuration Attention Report, or the Disk Configuration Warning Report display appear on the console?
- ◆ Yes: Continue with the next step.
  - ◆ No: Look at the product activity log. See [Using the product activity log](#) for details.

Is an SRC logged as a result of this IPL?

- ◇ Yes: Continue with the next step.
  - ◇ No: The problem is corrected. This ends the procedure.
9. Select option 5, press F11, then press Enter to display the details. Then, choose from the following options:
- ◆ If all of the reference codes are 0000, go to [LICIP11](#) and use cause code 0002.
  - ◆ If any of the reference codes are not 0000, continue with the next step and use the reference code that is not 0000.

**Note:** Use the characters in the *Type* column to find the correct reference code table.

10. Record the SRC on the Problem summary form. See the [Problem reporting forms](#) for details.

Are the SRC and unit reference code (URC) the same ones that sent you to this procedure?

- ◆ Yes: Continue with the next step.
  - ◆ No: Use the new SRC or reference code to correct the problem. See the [Reference code](#) topic. This ends the procedure.
11. Perform the following steps:
- a. Power off the system or expansion tower. See [Powering on and powering off](#).
  - b. Exchange the FRUs in the failing item list for the SRC you have now. Start with the highest probable cause of failure in the failing item column in the reference code list. See the [Reference code](#) topic. Perform the remaining steps of this procedure after you exchange each FRU until you determine the failing FRU.

**Note:** If you exchange a disk unit, do not attempt to save customer data until instructed to do so in this procedure.

12. Power on the system or the expansion unit.

Does an SRC appear on the control panel?

- ◆ No: Continue with the next step.
  - ◆ Yes: Go to step [15](#).
13. Does either the Disk Configuration Error Report, the Disk Configuration Attention Report, or the Disk Configuration Warning Report display appear on the console?
- ◆ Yes: Continue with the next step.
  - ◆ No: Look at the product activity log. See [Using the product activity log](#) for details.

Is an SRC logged as a result of this IPL?

- ◇ Yes: Continue with the next step.
- ◇ No: The last FRU you exchanged was failing.

**Note:** Before exchanging a disk unit, you should attempt to save customer data. Go to [Disk unit recovery procedures](#) before exchanging a disk unit.

This ends the procedure.

14. Select option 5, press F11, then press Enter to display the details. Then, choose from the following options:
  - ◆ If all of the reference codes are 0000, go to [LICIP11](#) and use cause code 0002.
  - ◆ If any of the reference codes are not 0000, go to step 10, and use the reference code that is not 0000.

**Note:** Use the characters in the *Type* column to find the correct reference code table.

15. Record the SRC on the Problem summary form. See [Using the product activity log](#) for details.

Is the SRC the same one that sent you to this procedure?

- ◆ Yes: The last FRU you exchanged is not the failing FRU. Go to step 11 to continue FRU isolation.
- ◆ No: Is the SRC B100 4504 or B100 4505 and have you exchanged disk unit 1 in the system unit, or are all the reference codes on the console 0000?
  - ◇ Yes: The last FRU you exchanged was failing. This ends the procedure.

**Note:** Before exchanging a disk unit, you should attempt to save customer data. See [Disk unit recovery procedures](#) before exchanging a disk unit.

- ◇ No: Use the new SRC or reference code to correct the problem. See the [Reference code](#) topic. This ends the procedure.

**Parent topic:** [I/O processor \(IOP\) isolation procedures](#)

---

## IOPIP13

Use this procedure to isolate problems on the interface between the I/O card and the storage devices.

The unit reference code (part of the SRC that sent you to this procedure) indicates the SCSI bus that has the problem:

| Unit reference code (URC) | SCSI bus |
|---------------------------|----------|
| 3100                      | 0        |
| 3101                      | 1        |
| 3102                      | 2        |
| 3103                      | 3        |

1. If the system has logical partitions, perform this procedure from the logical partition that reported the problem. To determine if the system has logical partitions, go to [Determining if the system has logical partitions](#).
2. Were you performing an IPL from removable media (IPL type D) when the error occurred?
  - ◆ No: Continue with the next step.
  - ◆ Yes: Exchange the FRUs in the failing item list for the reference code that sent you to this procedure. This ends the procedure.
3. Perform the following steps:

- a. Look in the service action log (see [Using the Service Action Log](#)) for other errors logged at or around the same time as the 310x SRC.
  - b. If no entries appear in the service action log, use the product activity log (see [Using the product activity log](#)).
  - c. Use the other SRCs to correct the problem before performing an IPL. See the [System reference codes](#) topic.
  - d. Contact your next level of support as necessary for assistance with SCSI bus problem isolation.
  - e. If the problem is not corrected, continue with the next step.
4. Perform an IPL to DST. See [Performing an IPL to DST](#). Does an SRC appear on the control panel?
    - ◆ No: Continue with the next step.
    - ◆ Yes: Go to step 7.
  5. Does one of the following displays appear on the console?
    - ◆ Disk Configuration Error Report
    - ◆ Disk Configuration Attention Report
    - ◆ Disk Configuration Warning Report
    - ◆ Display Unknown Mirrored Load-Source Status
    - ◆ Display Load-Source Failure
      - ◇ Yes: Continue with the next step.
      - ◇ No: Look at the product activity log. See [Using the product activity log](#) for details.

Is an SRC logged as a result of this IPL?

    - ◇ Yes: Continue with the next step.
    - ◇ No: You cannot continue isolating the problem. Use the original SRC and exchange the failing items, starting with the highest probable cause of failure see the failing item list for this reference code in the [Reference codes](#) topic. If the failing item list contains FI codes, see the [Using failing item codes](#) topic to help determine part numbers and location in the system. This ends the procedure.
  6. Are all of the reference codes 0000? On some of the displays, you must press F11 to display reference codes.
    - ◆ No: Continue with the next step. Use the reference code that is not 0000.
    - ◆ Yes: Go to [LICIP11](#) and use cause code 0002. This ends the procedure.
  7. Is the SRC the same one that sent you to this procedure?
    - ◆ Yes: Continue with the next step.
    - ◆ No: Record the SRC on the [Using the problem reporting forms](#). Then go to the [Reference codes](#) topic to correct the problem. This ends the procedure.
  8. Perform the following:
    - a. Power off the system or the expansion tower. See [Powering on and powering off](#) for details.
    - b. Find the I/O card identified in the failing item list.
    - c. Remove the I/O card and install a new I/O card. See [Removing and replacing parts](#). This item has the highest probability of being the failing item.
    - d. Power on the system or the expansion tower.

Does an SRC appear on the control panel?

    - ◆ No: Continue with the next step.
    - ◆ Yes: Go to step 12.
  9. Does one of the following displays appear on the console?
    - ◆ Disk Configuration Error Report
    - ◆ Disk Configuration Attention Report
    - ◆ Disk Configuration Warning Report
    - ◆ Display Unknown Mirrored Load-Source Status
    - ◆ Display Load-Source Failure
    - ◆ Yes: Does the Display Unknown Mirrored Load-Source Status display appear on the console?

**Note:** On some of these displays, you must press F11 to display reference codes.

    - ◇ Yes: Continue with the next step.
    - ◇ No: Are all of the reference codes 0000?
      - No: Go to step 12 using the reference code that is not 0000.
      - Yes: Go to [LICIP11](#) and use cause code 0002. This ends the procedure.
    - ◆ No: Go to step 11.
  10. Is the reference code the same one that sent you to this procedure?

- ◆ No: Either a new reference code occurred, or the reference code is 0000. There may be more than one problem. The original I/O card may be failing, but it must be installed in the system to continue problem isolation. Install the original I/O card by doing the following:
  - a. Power off the system or the expansion tower. See [Powering on and powering off](#) for details.
  - b. Remove the I/O card you installed in step 8 and install the original I/O card.

**Note:** Do not power on the system or the expansion unit now.

A device connected to the I/O card could be the failing item. Go to [IOPIP16](#), step (9) to continue isolating the problem. This ends the procedure.

- ◆ Yes: Go to step 13.
11. Look at the product activity log. See [Using the product activity log](#) for details. Is an SRC logged as a result of this IPL?
    - ◆ Yes: Continue with the next step.
    - ◆ No: The I/O card, which you removed in step 8, is the failing item. This ends the procedure.
  12. Is the SRC or reference code the same one that sent you to this procedure?
    - ◆ Yes: Continue with the next step.
    - ◆ No: Record the SRC on the [Using the problem reporting forms](#). Then go to the [Reference codes](#) topic to correct the problem. This ends the procedure.
  13. The original I/O card is not the failing item. Install the original I/O card by doing the following:
    - a. Power off the system or the expansion tower. See [Powering on and powering off](#) for details.
    - b. Remove the I/O card you installed in step 8 of this procedure and install the original I/O card.

**Note:** Do not power on the system or the expansion unit now.

A device connected to the I/O card could be the failing item. Go to [IOPIP16](#), step (9) to continue isolating the problem. This ends the procedure.

**Parent topic:** [I/O processor \(IOP\) isolation procedures](#)

---

## IOPIP16

Use this procedure to isolate failing devices that are identified by FI codes FI01105, FI01106, and FI01107.

During this procedure, you will remove devices that are identified by the FI code, and then you will perform an IPL to determine if the symptoms of the failure have disappeared, or changed. You should not remove the load-source disk until you have shown that the other devices are not failing. Removing the load-source disk can change the symptom of failure, although it is not the failing unit.

1. If the system has logical partitions, perform this procedure from the logical partition that reported the problem. To determine if the system has logical partitions, go to [Determining if the system has logical partitions](#) before continuing with this procedure.
2. Use the Hardware Service Manager (HSM) verify function (use DST or SST), and verify that all tape and optical units attached to the SCSI bus (identified by FI01105, FI01106, or FI01107) are operating correctly. See [Verification procedures](#) for details.

**Note:** Do not IPL the system to get to DST.

3. Choose from the following options:
  - ◆ If verification was successful for all tape and optical units, then go to step 5.

- ◆ If any tape or optical device could not be verified, or if it failed verification, then exchange the failing item. See the [Removing and replacing parts](#) and continue with the next step.
4. Use the Hardware Service Manager (HSM) verify function (use SST or DST) and verify that the exchanged item is operating correctly. See [Verification procedures](#) for details.

Was the verification successful?

- ◆ No: Replace the exchanged device with the original. See [Removing and replacing parts](#) and continue with the next step.
  - ◆ Yes: The newly exchanged tape or optical device was the failing item. This ends the procedure.
5. Perform an IPL to DST. See [Performing an IPL to DST](#).

Does an SRC appear on the control panel?

- ◆ No: Continue with the next step.
  - ◆ Yes: Go to step 8.
6. Does one of the following displays appear on the console?
    - ◆ Disk Configuration Error Report
    - ◆ Disk Configuration Attention Report
    - ◆ Disk Configuration Warning Report
    - ◆ Display Unknown Mirrored Load-Source Status
    - ◆ Display Load-Source Failure

**Note:** On some of these displays, you must press F11 to display reference codes. The characters under Type are the same as the 4 leftmost characters of word 1. The characters under Reference Code are the same as the 4 rightmost characters of word 1.

- ◇ No: Continue with the next step.
  - ◇ Yes: Are all of the reference codes 0000?
    - No: Go to step 8, and use the reference code that is not 0000.
    - Yes: Go to [LICIP11](#) and use cause code 0002. This ends the procedure.
7. Look at the Product Activity Log. See [Using the product activity log](#) for details.

Is a reference code logged as a result of this IPL?

- ◆ Yes: Continue with the next step.
  - ◆ No: You cannot continue isolating the problem. Use the original reference code and exchange the failing items, starting with the highest probable cause of failure. See the failing item list for this reference code in the [Reference codes](#) topic. If the failing item list contains FI codes, see [Using failing item codes](#) for additional details. This ends the procedure.
8. Is the SRC or reference code the same one that sent you to this procedure?
    - ◆ Yes: Continue with the next step.
    - ◆ No: Record the SRC or reference code on the [Problem reporting forms](#). Then, go to the [Reference codes](#) topic to correct the problem. This ends the procedure.
  9. Isolate the failing device by doing the following:
    - a. Power off the system or the expansion unit if it is powered on. See [Powering on and powering off](#).
    - b. Go to [Using failing item codes](#) to find the devices identified by FI code FI01105, FI01106, or FI01107 in the failing item list.
    - c. Disconnect one of the devices that are identified by the FI code, other than the load-source disk unit.

**Note:** The tape, or optical units should be the first devices to be disconnected, if they are attached to the SCSI bus identified by FI01105, FI01106, or FI01107.

- d. Go to step 11.
10. Continue to isolate the possible failing items by doing the following:
    - a. Power off the system or the expansion unit. See [Powering on and powering off](#).

- b. Disconnect the next device that is identified by FI codes FI01105, FI01106, or FI01107 in the FRU list. See the note in step 9. Do not disconnect disk unit 1 (load-source disk) until you have disconnected all other devices and the load-source disk is the last device that is identified by these FI codes.

11. Power on the system or the expansion tower.

Does an SRC appear on the control panel?

- ◆ No: Continue with the next step.
- ◆ Yes: Go to step 14.

12. Does one of the following displays appear on the console?

- ◆ Disk Configuration Error Report
- ◆ Disk Configuration Attention Report
- ◆ Disk Configuration Warning Report
- ◆ Display Unknown Mirrored Load-Source Status
- ◆ Display Load-Source Failure

**Note:** On some of these displays, you must press F11 to display reference codes. The characters under Type are the same as the 4 leftmost characters of word 1. The characters under Reference Code are the same as the 4 rightmost characters of word 1.

◇ Yes: Go to step 14.

◇ No: Look at the Product Activity Log. See [Using the product activity log](#) for details. Is a reference code logged as a result of this IPL?

· No: Continue with the next step.

· Yes: Go to step 14.

13. You are here because the IPL completed successfully. The last device you disconnected is the failing item.

Is the failing item a disk unit?

- ◆ No: Exchange the failing item and reconnect the devices you disconnected previously. See the [Removing and replacing parts](#). This ends the procedure.
- ◆ Yes: Exchange the failing FRU. Before exchanging a disk drive, you should attempt to save customer data. Go to [Disk unit recovery procedures](#) before exchanging a disk unit. This ends the procedure.

14. Is the SRC or reference code the same one that sent you to this procedure?

- ◆ Yes: Continue with the next step.
- ◆ No: Record the SRC or reference code on the Problem summary form. Then go to step 16.

15. The last device you disconnected is not failing.

Have you disconnected all the devices that are identified by FI codes FI01105, FI01106, or FI01107 in the FRU list?

- ◆ No: Leave the device disconnected and return to step 10 to continue isolating the possible failing items.
- ◆ Yes: Replace the device backplane or backplanes associated with the devices you removed in the earlier steps. If the device backplane does not fix the problem, then you cannot continue isolating the problem. Use the original SRC and exchange the failing items, starting with the highest probable cause of failure. See the failing item list for this reference code in the [Reference codes](#) topic. If the failing item list contains FI codes, see [Using failing item codes](#) for additional information. This ends the procedure.

16. Is the SRC B1xx 4504, and have you disconnected the load-source disk unit? (The load-source disk unit is disconnected by disconnecting disk unit 1.)

- ◆ Yes: Continue with the next step.
- ◆ No: Does one of the following displays appear on the console, and are all reference codes 0000?
  - ◇ Disk Configuration Error Report
  - ◇ Disk Configuration Attention Report
  - ◇ Disk Configuration Warning Report
  - ◇ Display Unknown Mirrored Load-Source Status
  - ◇ Display Load-Source Failure

**Note:** On some of these displays, you must press F11 to display reference codes. The characters under Type are the same as the 4 leftmost characters of word 1. The characters under Reference Code are the same as the 4 rightmost characters of word 1.

- Yes: Continue with the next step.
  - No: A new SRC or reference code occurred. Go to the [Reference codes](#) topic to correct the problem. This ends the procedure.
17. The last device you disconnected may be the failing item. Exchange the last device you disconnected. See the [Removing and replacing parts](#).

**Note:** Before exchanging a disk drive, you should attempt to save customer data. Go to [Disk unit recovery procedures](#) before exchanging a disk unit.

Was the problem corrected by exchanging the last device you disconnected?

- ◆ No: Continue with the next step.
  - ◆ Yes: This ends the procedure.
18. Reconnect the devices you disconnected previously in this procedure.
19. Use the original SRC and exchange the failing items, starting with the highest probable cause of failure. See the failing item list for this reference code in the [Reference codes](#) topic. Do not exchange the FRU that you exchanged in this procedure. If the failing item list contains FI codes, see [Using failing item codes](#) to help determine part numbers and location in the system. This ends the procedure.

**Parent topic:** [I/O processor \(IOP\) isolation procedures](#)

---

## IOPIP17

Use this procedure to isolate problems that are associated with SCSI bus configuration errors and device task initialization failures.

1. If the system has logical partitions, perform this procedure from the logical partition that reported the problem. To determine if the system has logical partitions, go to [Determining if the system has logical partitions](#) before continuing with this procedure.
2. Were you performing an IPL from removable media (IPL type D) when the error occurred?
  - ◆ Yes: Exchange the FRUs in the failing item list for the reference code that sent you to this procedure.
  - ◆ No: Perform an IPL to DST. See [Performing an IPL to DST](#). Does an SRC appear on the control panel?
    - ◇ No: Continue with the next step.
    - ◇ Yes: Go to step 5.
3. Does either the Disk Configuration Error Report, the Disk Configuration Attention Report, or the Disk Configuration Warning Report display appear on the console?
  - ◆ No: Continue with the next step.
  - ◆ Yes: Does one of the following messages appear in the list?
    - ◇ Missing disk units in the configuration
    - ◇ Missing mirror protection disk units in the configuration
    - ◇ Device parity protected units in exposed mode.
      - No: Continue with the next step.
      - Yes: Select option 5, press F11, then press Enter to display the details. Then, choose from the following options:
        - If all of the reference codes are 0000, go to [LICIP11](#) and use cause code 0002.
        - If any of the reference codes are not 0000, go to step 5, and use the reference code that is not 0000.

**Note:** Use the characters in the *Type* column to find the correct reference code table.

4. Look at the product activity log. See [Using the Service Action Log](#). Is an SRC logged as a result of this IPL?
  - ◆ Yes: Continue with the next step.
  - ◆ No: You cannot continue isolating the problem. Use the original SRC and exchange the failing items, starting with the highest probable cause of failure (see the failing item list for this reference code in the (System Reference Codes)) topic. If the failing item list contains FI codes, see (Failing items) to help determine part numbers and location in the system. This ends the procedure.
5. Record the SRC on the Problem summary form. See [Problem reporting forms](#) for details. Is the SRC the same one that sent you to this procedure?
  - ◆ No: A different SRC or reference code occurred. Use the new SRC or reference code to correct the problem. See [Start of call procedure](#). This ends the procedure.
  - ◆ Yes: Determine the device unit reference code (URC) from the SRC. If the Disk Configuration Error Report, the Disk Configuration Attention Report, or the Disk Configuration Warning Report display appears on the console, the device URC is displayed under *Reference Code*. This is on the same line as the missing device. Is the device unit reference code 3020, 3021, 3022, or 3023?
    - ◇ Yes: Continue with the next step.
    - ◇ No: Go to step 7.
6. A unit reference code of 3020, 3021, 3022, or 3023 indicates that there is a problem on an I/O card SCSI bus. The problem can be caused by a device that is attached to the I/O card that:
  - ◆ Is not supported.
  - ◆ Does not match system configuration rules. For example, there are too many devices that are attached to the bus.
  - ◆ Is failing.

Perform the following:

- a. Look at the characters on the control panel Data display or the Problem Summary Form for characters 9 - 16 of the top 16 character line of function 12 (word 3). Use the format BBBB-Cc-bb (BBBB = bus, Cc = card, bb = board) to determine the card slot location for the I/O card (see (Locations and addresses)).
- b. The unit reference code indicates the SCSI bus that has the problem:

| URC  | SCSI Bus |
|------|----------|
| 3020 | 0        |
| 3021 | 1        |
| 3022 | 2        |
| 3023 | 3        |

- c. To find the bus and device locations, see [Finding part locations](#).
- d. Find the printout that shows the system configuration from the last IPL and compare it to the present system configuration.

**Note:** If configuration is not the problem, a device on the SCSI bus may be failing.

- e. If you need to perform isolation on the SCSI bus, go to [IOPIP16](#). This ends the procedure.
7. The possible failing items are FI codes FI01105 (90%) and FI01112 (10%). Find the device unit address from the SRC (see [The System Reference Code \(SRC\) Format Description](#)). Use this information to find the physical location of the device. Record the type and model numbers to determine if the addressed I/O card supports this device. Is the device given support on your system?
  - ◆ No: Continue with the next step.
  - ◆ Yes: Perform the following:
    - a. Exchange the device.
    - b. Perform an IPL to DST. See [Performing an IPL to DST](#).



Does this correct the problem?

◇ No: Ask your next level of support for assistance. This ends the procedure.

◇ Yes: This ends the procedure.

8. Perform the following steps:

a. Remove the device.

b. Perform an IPL to DST. See [Performing an IPL to DST](#).

Does this correct the problem?

◆ No: Ask your next level of support for assistance. This ends the procedure.

◆ Yes: This ends the procedure.

**Parent topic:** [I/O processor \(IOP\) isolation procedures](#)

---

## IOPIP18

Use this procedure to isolate problems that are associated with SCSI bus configuration errors and device task initialization failures.

1. If the system has logical partitions, perform this procedure from the logical partition that reported the problem. To determine if the system has logical partitions, go to [Determining if the system has logical partitions](#) before continuing with this procedure.
2. Perform an IPL to DST. See [Performing an IPL to DST](#).

Does an SRC appear on the control panel?

◆ Yes: Go to step 5.

◆ No: Does either the Disk Configuration Error Report, the Disk Configuration Attention Report, or the Disk Configuration Warning Report display appear on the console?

◇ Yes: Continue with the next step.

◇ No: Go to step 4.

3. Does one of the following messages appear in the list?

◆ Missing disk units in the configuration

◆ Missing mirror protection disk units in the configuration

◆ Device parity protected units in exposed mode.

◇ No: Continue with the next step.

◇ Yes: Select option 5, press F11, and then press Enter to display the details. Choose from the following options:

· If all of the reference codes are 0000, go to [LICIP11](#) and use cause code 0002.

· If any of the reference codes are not 0000, go to step 5, and use the reference code that is not 0000.

**Note:** Use the characters in the *Type* column to find the correct reference code table.

4. Look at the product activity log (see (Log) for details).

Is an SRC logged as a result of this IPL?

◆ Yes: Continue with the next step.

◆ No: You cannot continue isolating the problem. Use the original SRC and exchange the failing items, starting with the highest probable cause of failure in the failing item column in the reference code list. See the [Reference codes](#) topic. If the failing item list contains FI codes, see [Using failing item codes](#) to help determine part numbers and location in the system. This ends the procedure.

5. Record the SRC on the Problem summary form. See the [Problem reporting forms](#).

Is the SRC the same one that sent you to this procedure?

◆ Yes: Continue with the next step.

- ◆ No: A different SRC or reference code occurred. Use the new SRC or reference code to correct the problem. See [Start of call procedure](#). This ends the procedure.
6. Determine the device unit reference code (URC) from the SRC. If the Disk Configuration Error Report, the Disk Configuration Attention Report, or the Disk Configuration Warning Report display appears on the console, the device URC is displayed under *Reference Code*. This is on the same line as the missing device.

Is the device unit reference code 3020?

- ◆ No: Continue with the next step.
  - ◆ Yes: A device reference code of 3020 indicates that a device is attached to the addressed I/O card. Either it is not supported, or it does not match system configuration rules. For example, there are too many devices that are attached to the bus. Perform the following steps:
    - a. Find the printout that shows the system configuration from the last IPL and compare it to the present system configuration.
    - b. Use the unit address and the physical address in the SRC to help you with this comparison.
    - c. If configuration is not the problem, a device on the SCSI bus may be failing. Use FI code FI00884 in the [Using failing item codes](#) table to help find the failing device.
    - d. If you need to perform isolation on the SCSI bus, go to [IOPIP16](#). This ends the procedure.
7. The possible failing items are FI codes FI01105 (90%) and FI01112 (10%).

Find the device unit address from the SRC. Use this information to find the physical location of the device. Record the type and model numbers to determine if the addressed I/O card supports this device.

Is the device given support on your system?

- ◆ No: Continue with the next step.
  - ◆ Yes: Perform the following steps:
    - a. Exchange the device.
    - b. Perform an IPL to DST. See [Performing an IPL to DST](#).
 Does this correct the problem?
    - ◇ No: Ask your next level of support for assistance. This ends the procedure.
    - ◇ Yes: This ends the procedure.
8. Perform the following steps:
  - a. Remove the device.
  - b. Perform an IPL to DST. See [Performing an IPL to DST](#).
 Does this correct the problem?
  - ◆ No: Ask your next level of support for assistance. This ends the procedure.
  - ◆ Yes: This ends the procedure.

**Parent topic:** [I/O processor \(IOP\) isolation procedures](#)

---

## IOPIP19

You were sent to this procedure from unit reference code (URC) 9010, 9011, or 9013.

Contact your next level of support for assistance.

**Parent topic:** [I/O processor \(IOP\) isolation procedures](#)

---

## IOPIP20

Use this procedure to isolate the problem when two or more devices are missing from a disk array.

You were sent to this procedure from unit reference code (URC) 9020 or 9021.

1. If the system has logical partitions, perform this procedure from the logical partition that reported the problem. To determine if the system has logical partitions, go to [Determining if the system has logical partitions](#), before continuing with this procedure.
2. Access SST/DST by doing one of the following:
  - ◆ If you can enter a command at the console, access system service tools (SST). See [System Service Tools \(SST\)](#).
  - ◆ If you cannot enter a command at the console, perform an IPL to DST. See [Performing an IPL to DST](#).
  - ◆ If you cannot perform a type A or B IPL, perform a type D IPL from removable media.
3. Have any other I/O card or device SRCs (other than a 902F SRC) occurred at about the same time as this error?
  - ◆ Yes: Use the other I/O card or device SRCs to correct the problem. See the [Reference codes](#) topic. This ends the procedure.
  - ◆ No: Has the I/O card, or have the devices been repaired or reconfigured recently?
    - ◇ Yes: Continue with the next step.
    - ◇ No: Contact your next level of support for assistance. This ends the procedure.
4. Did you perform a D IPL to get to DST?
  - ◆ Yes: Continue with the next step.
  - ◆ No: Perform the following steps:
    - a. Access the Product Activity Log and display the SRC that sent you here and view the "Additional Information" to record the formatted log information. Record all devices that are missing from the disk array. These are the array members that have both a present address of 0 and an expected address that is not 0.

**Note:** There might be more than one Product Activity Log entry with the same Log ID. Access any additional entries by pressing the enter key from the "Display Detail Report for Resource" screen. View the "Additional Information" for each entry to record the formatted log information.

For example: There might be an xxxx902F SRC entry in the Product Activity Log if there are more than 10 disk units in the array.

b. Continue with step 6.

5. A formatted display of hexadecimal information for Product Activity Log entries is not available. In order to interpret the hexadecimal information, see [More information from hexadecimal reports](#). Record all devices that are missing from the disk array. These are the array members that have both a present address of 0 and an expected address that is not 0.

**Note:** There might be an xxxx902F SRC entry in the Product Activity Log if there are more than 10 disk units in the array. In order to interpret the hexadecimal information for these additional disk units, see [More information from hexadecimal reports](#).

6. There are three possible ways to correct the problem:
  - a. Find the missing devices and install them in the correct physical locations in the system. If you can find the missing devices and want to continue with this repair option, then continue with the next step.
  - b. Stop the disk array that contains the missing devices.

**Attention:** Customer data might be lost.

If you want to continue with this repair option, go to step 8.

- c. Initialize and format the remaining members of the disk array.

**Attention:** Customer data will be lost.

If you want to continue with this repair option, go to step 9.

7. Perform the following:
  - a. Install the missing devices in the correct locations in the system. See the [Removing and replacing parts](#).
  - b. Power on the system. See [Powering on and powering off](#).

Does the IPL complete successfully?

  - ◆ No: Go to [Start of call procedure](#). This ends the procedure.
  - ◆ Yes: This ends the procedure.
8. You have chosen to stop the disk array that contains the missing devices.

**Attention:** Customer data might be lost.

Perform the following:

- a. If you are not already using dedicated service tools, perform an IPL to DST. See [Performing an IPL to DST](#).

If you cannot perform a type A or B IPL, perform a type D IPL from removable media.

- b. Select Work with disk units.

Did you get to DST with a Type D IPL?

- ◇ Yes: Continue with the next step.
- ◇ No: Select Work with disk configuration > Work with device parity protection. Then, continue with the next step.

- c. Select Stop device parity protection.
- d. Follow the on-line instructions to stop device parity protection.
- e. Perform an IPL from disk.

Does the IPL complete successfully?

- ◆ No: Go to [Start of call procedure](#). This ends the procedure.
- ◆ Yes: This ends the procedure.

9. You have chosen to initialize and format the remaining members of the disk array. Perform the following steps:

**Attention:** Customer data will be lost.

- a. If you are not already using dedicated service tools, perform an IPL to DST. See [Performing an IPL to DST](#).

If you cannot perform a type A or B IPL, perform a type D IPL from removable media.

- b. Select Work with disk units.

Did you get to DST with a Type D IPL?

- ◇ Yes: Continue with the next step.
- ◇ No: Select Work with disk unit recovery > Disk unit problem recovery procedures, and continue with the next step.

10. Select Initialize and format disk unit.
11. Follow the online instructions to format and initialize the disk units.
12. Perform an IPL from disk. Does the IPL complete successfully?
  - ◆ No: Go to the [Start of call procedure](#). This ends the procedure.

- ◆ Yes: This ends the procedure.

**Parent topic:** [I/O processor \(IOP\) isolation procedures](#)

---

## IOPIP21

Use this procedure to determine the failing disk unit when, a disk unit is not compatible with other disk units in the disk array, or when a disk unit has failed. If the URC is 9025 or 9030, the disk array is running, but it might not be protected.

You were sent to this procedure from a unit reference code (URC) of 9025, 9030, or 9032.

1. If the system has logical partitions, perform this procedure from the logical partition that reported the problem. To determine if the system has logical partitions, go to [Determining if the system has logical partitions](#) before continuing with this procedure.
2. Is the device location information for this SRC available in the Service Action Log (see [Using the Service Action Log](#) for details)?
  - ◆ Yes: Exchange the disk unit. See [Disk unit recovery procedures](#). This ends the procedure.
  - ◆ No: Continue with the next step.
3. Access SST/DST by doing one of the following:
  - ◆ If you can enter a command at the console, access system service tools (SST). See [System Service Tools \(SST\)](#).
  - ◆ If you cannot enter a command at the console, perform an IPL to DST. See [Performing an IPL to DST](#).
4. Perform the following steps:
  - a. Access the Product Activity Log and display the SRC that sent you here.
  - b. Press the F9 key for address information. This is the I/O card address.

**Note:** There may be more than one entry with the same Log ID. Entries with the same Log ID may be accessed by pressing the Enter key from the "Display Detail Report for Resource" screen.

Example: There may be a device specific SRC and/or an xxxx902F SRC entry in the Product Activity Log. The xxxx902F SRC will occur if there are more than 10 disk units in the array.

- c. Continue with the next step.
5. Perform the following steps:
  - a. Return to the SST or DST main menu.
  - b. Select Work with disk units > Display disk configuration > Display disk configuration status.
  - c. On the Display disk configuration status display, look for the devices attached to the I/O card that is identified in step 4.
  - d. Find the device that has a status of "DPY/Unknown" or "DPY/Failed". This is the device that is causing the problem. Show the device address by selecting Display Disk Unit Details > Display Detailed Address. Record the device address.
  - e. See [Finding part locations](#) and find the diagram of the system unit, or the expansion unit and find the following:
    - ◇ The card slot that is identified by the I/O card direct select address
    - ◇ The disk unit location that is identified by the device address

Have you determined the location of the I/O card and disk unit that is causing the problem?

- ◆ Yes: Exchange the disk unit that is causing the problem. See [Disk unit recovery procedures](#). This ends the procedure.
- ◆ No: Ask your next level of support for assistance. This ends the procedure.

**Parent topic:** [I/O processor \(IOP\) isolation procedures](#)

---

## IOPIP22

Use this procedure to gather error information and contact your next level of support.

1. If the system has logical partitions, perform this procedure from the logical partition that reported the problem. To determine if the system has logical partitions, go to [Determining if the system has logical partitions](#), before continuing with this procedure.
2. Access SST/DST by doing one of the following:
  - ◆ If you can enter a command at the console, access system service tools (SST). See [System Service Tools \(SST\)](#).
  - ◆ If you cannot enter a command at the console, perform an IPL to DST. See [Performing an IPL to DST](#).
  - ◆ If you cannot perform a type A or B IPL, perform a type D IPL from removable media.
3. Did you perform a D IPL to get to DST?
  - ◆ Yes: Continue with the next step.
  - ◆ No: Perform the following steps:
    - a. Access the Product Activity Log and display the SRC that sent you here and view the "Additional Information" to record the formatted log information. Record all the information.

**Note:** There may be more than one Product Activity Log entry with the same Log ID. Access any additional entries by pressing the Enter key from the "Display Detail Report for Resource" screen. View the "Additional Information" for each entry to record the formatted log information. Example: There may be an xxxx902F SRC entry in the Product Activity Log if there are more than 10 disk units in the array.

b. Continue with step 5.

4. A formatted display of hexadecimal information for Product Activity Log entries is not available. In order to interpret the hexadecimal information, see [More information from hexadecimal reports](#). Record all the information. Then continue with the next step.

**Note:** There may be an xxxx902F SRC entry in the Product Activity Log if there are more than 10 disk units in the array. In order to interpret the hexadecimal information for these additional disk units, see [More information from hexadecimal reports](#).

5. Ask your next level of support for assistance.

**Note:** Your next level of support may require the error information you recorded in the previous step.

This ends the procedure.

**Parent topic:** [I/O processor \(IOP\) isolation procedures](#)

---

## IOPIP23

You were sent to this procedure from a unit reference code (URC) 9050.

If the failing item is in a migrated tower, use the *(Migrated Expansion Tower Problem Analysis, Repair and Parts)* manual on the V5R1 Supplemental Manuals web site to fix the problem. Otherwise, contact your next level of support for assistance.

**Parent topic:** [I/O processor \(IOP\) isolation procedures](#)

---

## IOPIP25

Use this procedure to isolate the problem when a device attached to the I/O card has functions that are not given support on the I/O card.

You were sent to this procedure from URC 9008.

1. If the system has logical partitions, perform this procedure from the logical partition that reported the problem. To determine if the system has logical partitions, go to [Determining if the system has logical partitions](#), before continuing with this procedure.
2. Have any other I/O card or device SRCs occurred at about the same time as this error?
  - ◆ Yes: Use the other I/O card or device SRCs to correct the problem. See the (System Reference Codes). This ends the procedure.
  - ◆ No: Has the I/O card, or have the devices been repaired or reconfigured recently?
    - ◇ Yes: Continue with the next step.
    - ◇ No: Contact your next level of support for assistance. This ends the procedure.
3. Access SST/DST by doing one of the following:
  - ◆ If you can enter a command at the console, access system service tools (SST). [System Service Tools \(SST\)](#).
  - ◆ If you cannot enter a command at the console, perform an IPL to DST. See [Performing an IPL to DST](#).
  - ◆ If you cannot perform a type A or B IPL, perform a type D IPL from removable media.
4. Did you perform a D IPL to get to DST?
  - ◆ No: Access the Product Activity Log and display the SRC that sent you here. Press the F9 key for address information. This is the I/O card address. Then, view the "Additional Information" to record the formatted log information. Record the addresses that are not 0000 0000 for all devices listed.

Continue with the next step.

- ◆ Yes: Access the Product Activity Log and display the SRC that sent you here. The direct select address (DSA) of the I/O Card is in the format BBBB-Cc-bb:
  - ◇ BBBB = hexadecimal offsets 4C and 4D
  - ◇ Cc = hexadecimal offset 51
  - ◇ bb = hexadecimal offset 4F

The unit address of the I/O card is hexadecimal offset 18C through 18F.

A formatted display of hexadecimal information for Product Activity Log entries is not available. In order to interpret the hexadecimal information, see [More information from hexadecimal reports](#). Record the addresses that are not 0000 0000 for all devices listed. Continue with the next step.

5. See [Finding part locations](#) and find the diagram of the system unit, or the expansion unit. Then find the following:
  - ◆ The card slot that is identified by the I/O card direct select address (DSA) and unit address. If there is no IOA with a matching DSA and unit address, the IOP and IOA are one card. Use the IOP with the same DSA.
  - ◆ The disk unit locations that are identified by the unit addresses.

Have you determined the location of the I/O card and the devices that are causing the problem?

  - ◆ No: Ask your next level of support for assistance. This ends the procedure.
  - ◆ Yes: Have one or more devices been moved to this I/O card from another I/O card?
    - ◇ Yes: Continue with the next step.
    - ◇ No: Ask your next level of support for assistance. This ends the procedure.
6. Is the I/O card capable of supporting the devices attached, or is it in the correct mode to support the devices attached?

**Note:** For information on I/O card modes, see [Storage I/O card modes and jumpers](#).

- ◆ No: Remove the devices from the I/O card. See [Disk unit recovery procedures](#).

**Note:** You can remove disk units without installing another disk unit, and the system continues to operate.

This ends the procedure.

- ◆ Yes: Do you want to continue using these devices with this I/O card?
  - ◇ Yes: Continue with the next step.
- ◆ No: Either change the I/O card mode or remove the devices from the I/O card. See [Disk unit recovery procedures](#).

**Note:** You can remove disk units without installing other disk units and the system continues to operate.

This ends the procedure.

7. Initialize and format the disk units by performing the following steps:

**Attention:** Data on the disk unit will be lost.

- a. Access SST or DST.
- b. Select Work with disk units.

Did you get to DST with a Type D IPL?

- ◇ Yes: Continue with the next step.
  - ◇ No: Select Work with disk unit recovery > Disk unit problem recovery procedures. Then continue with the next step.
- c. Select Initialize and format disk unit for each disk unit. When the new disk unit is initialized and formatted, the display shows that the status is complete. This may take 30 minutes or longer. The disk unit is now ready to be added to the system configuration. This ends the procedure.

**Parent topic:** [I/O processor \(IOP\) isolation procedures](#)

---

## IOPIP26

Use this procedure to correct the problem when the I/O card recognizes that the attached disk unit must be initialized and formatted.

You were sent to this procedure from URC 9092.

1. If the system has logical partitions, perform this procedure from the logical partition that reported the problem. To determine if the system has logical partitions, go to [Determining if the system has logical partitions](#) before continuing with this procedure.
2. Have any other I/O card or device SRCs occurred at about the same time as this error?
  - ◆ Yes: Use the other I/O card or device SRCs to correct the problem. See the [Reference codes](#) topic. This ends the procedure.
  - ◆ No: Has the I/O card, or have the devices been repaired or reconfigured recently?
    - ◇ Yes: Continue with the next step.
    - ◇ No: Contact your next level of support for assistance. This ends the procedure.
3. Access SST/DST by doing one of the following:



- ◆ If you can enter a command at the console, access system service tools (SST). See [System Service Tools \(SST\)](#).
  - ◆ If you cannot enter a command at the console, perform an IPL to DST. See [Performing an IPL to DST](#) for details.
  - ◆ If you cannot perform a type A or B IPL, perform a type D IPL from removable media.
4. Did you perform a D IPL to get to DST?
- ◆ Yes: Continue with the next step.
  - ◆ No: Perform the following steps:
    - a. Access the Product Activity Log and display the SRC that sent you here.
    - b. Press the F9 key for address information. This is the I/O card address.
    - c. Then view the "Additional Information" to record the formatted log information.
    - d. Record the addresses that are not 0000 0000 for all devices listed.
    - e. Continue with step 6.
5. Perform the following steps:
- a. Access the Product Activity Log and display the SRC that sent you here. The direct select address (DSA) of the I/O card is in the format BBBB-Cc-bb:
    - ◇ BBBB = hexadecimal offsets 4C and 4D
    - ◇ Cc = hexadecimal offset 51
    - ◇ bb = hexadecimal offset 4F

The unit address of the I/O card is hexadecimal offset 18C through 18F.
  - b. A formatted display of hexadecimal information for Product Activity Log entries is not available. In order to interpret the hexadecimal information, see [More information from hexadecimal reports](#). Record the addresses that are not 0000 0000 for all devices listed.
  - c. Continue with the next step.
6. See [Finding part locations](#) and find the diagram of the system unit, or the expansion unit. Then find the following:
- ◆ The card slot that is identified by the I/O card direct select address (DSA) and unit address. If there is no IOA with a matching DSA and unit address, the IOP and IOA are one card. Use the IOP with the same DSA.
  - ◆ The disk unit locations that are identified by the unit addresses.
- Have you determined the location of the I/O card and the devices that are causing the problem?
- ◆ No: Ask your next level of support for assistance. This ends the procedure.
  - ◆ Yes: Have one or more devices been moved to this I/O card from another I/O card?
    - ◇ Yes: Continue with the next step.
    - ◇ No: Ask your next level of support for assistance. This ends the procedure.
7. Do you want to continue using these devices with this I/O card?
- ◆ Yes: Continue with the next step.
  - ◆ No: Remove the devices from the I/O card. See [Disk unit recovery procedures](#).

**Note:** You can remove disk units without installing another disk unit, and the system continues to operate.

This ends the procedure.

8. Initialize and format the disk units by performing the following steps:

**Attention:** Data on the disk unit will be lost.

- a. Access SST or DST.
- b. Select Work with disk units.

Did you get to DST with a Type D IPL?

- ◇ Yes: Continue with the next step.
  - ◇ No: Select Work with disk unit recovery > Disk unit problem recovery procedures. Then continue with the next step.
- c. Select Initialize and format disk unit for each disk unit. When the new disk unit is initialized and formatted, the display shows that the status is complete. This may take 30 minutes or

longer. The disk unit is now ready to be added to the system configuration. This ends the procedure.

**Parent topic:** [I/O processor \(IOP\) isolation procedures](#)

---

## IOIP27

I/O card cache data exists for a missing or failed device.

You were sent to this procedure from a unit reference code (URC) of 9051.

**Note:** For some storage I/O adapters, the cache card is integrated and not removable.

Having I/O card cache data for a missing or failed device might be caused by the following conditions:

- One or more disk units have failed on the I/O card.
- The cache card of the I/O card was not cleared before it was shipped as a MES to the customer. In addition, the service representative moved devices from the I/O card to a different I/O card before performing a system IPL.
- The cache card of the I/O card was not cleared before it was shipped to the customer. In addition, residual data was left in the cache card for disk units that manufacturing used to test the I/O card.
- The I/O card and cache card were moved from a different system or a different location on this system after an abnormal power off.
- One or more disk units were moved either concurrently, or they were removed after an abnormal power off.

**CAUTION:** Any Function 08 power down (including from a D-IPL) is an abnormal power off.

1. If the system has logical partitions, perform this procedure from the logical partition that reported the problem. To determine if the system has logical partitions, go to [Determining if the system has logical partitions](#) before continuing with this procedure.
2. Access SST/DST by doing one of the following:
  - ◆ If you can enter a command at the console, access system service tools (SST). See [System Service Tools \(SST\)](#).
  - ◆ If you cannot enter a command at the console, perform an IPL to DST. See [Performing an IPL to DST](#).
  - ◆ If you cannot perform a type A or B IPL, perform a type D IPL from removable media.
3. Did you perform a D IPL to get to DST?
  - ◆ Yes: Continue with the next step.
  - ◆ No: Perform the following steps:
    - a. Access the Product Activity Log and display the SRC that sent you here.
    - b. Press the F9 key for address information. This is the I/O card address.
    - c. Then view the "Additional Information" to record the formatted log information. Record the device types and serial numbers for those devices that show a unit address of 0000 0000.
    - d. Continue with step 5.
4. Perform the following steps:
  - a. Access the Product Activity Log and display the SRC that sent you here. The direct select address (DSA) of the I/O card is in the format BBBB-Cc-bb:
    - ◆ BBBB = hexadecimal offsets 4C and 4D.
    - ◆ Cc = hexadecimal offset 51
    - ◆ bb = hexadecimal offset 4F
 The unit address of the I/O card is hexadecimal offset 18C through 18F.

- A formatted display of hexadecimal information for Product Activity Log entries is not available. In order to interpret the hexadecimal information, see [More information from hexadecimal reports](#).
- b. Record the device types and serial numbers for those devices that show a unit address of 0000 0000.
  - c. Continue with the next step.
5. See [Finding part locations](#) and find the diagram of the system unit, or the expansion unit. Find the card slot that is identified by the I/O card direct select address (DSA) and unit address. If there is no IOA with a matching DSA and unit address, the IOP and IOA are one card. Use the IOP with the same DSA.
  6. Choose from the following options:
    - ◆ If the devices from step 3 of this procedure have never been installed on this system, continue with the next step.
    - ◆ If the devices are not in the current system disk configuration, go to step 9.
    - ◆ Otherwise, the devices are part of the system disk configuration; go to step 11.
  7. Choose from the following options:
    - ◆ If this I/O card and cache card were moved from a different system, continue with the next step.
    - ◆ Otherwise, the cache card was shipped to the customer without first being cleared. Perform the following:
      - a. Make a note of the serial number, the customer number, and the device types and their serial numbers. These were found in step 3.
      - b. Inform your next level of support.
      - c. Then go to step 10 to clear the cache card and correct the URC 9051 problem.
  8. Install both the I/O card and the cache cards back into their original locations. Then re-IPL the system. There could be data in the cache card for devices in the disk configuration of the original system. After an IPL to DST and a normal power off on the original system, the cache card will be cleared. It is then safe to move the I/O card and the cache card to another location.
  9. One or more devices that are not currently part of the system disk configuration were installed on this I/O card. Either they were removed concurrently, they were removed after an abnormal power off, or they have failed. Continue with the next step.
  10. Use the Reclaim IOP cache storage procedure to clear data from the cache for the missing or failed devices as follows:
    - a. Perform an IPL to DST. See [Performing an IPL to DST](#).

If you cannot perform a type A or B IPL, perform a type D IPL from removable media.

    - b. Reclaim the cache adapter card storage. See [Reclaiming IOP cache storage](#).
  11. Choose from the following options:
    - ◆ If this I/O card and cache card were moved from a different location on this system, go to step 8.
    - ◆ If the devices from step 3 of this procedure are now installed on another I/O card, and they were moved there before the devices were added to the system disk configuration, go to step 7. (On an MES, the disk units are sometimes moved from one I/O card to another I/O card. This problem will result if manufacturing did not clear the cache card before shipping the MES.)
    - ◆ Otherwise, continue with the next step.
  12. One or more devices that are currently part of the system disk configuration are either missing or failed, and have data in the cache card. Consider the following:
    - ◆ The problem may be because devices were moved from the I/O card concurrently, or they were removed after an abnormal power off. If this is the case, locate the devices, power off the system and install the devices on the correct I/O card.
    - ◆ If no devices were moved, look for other errors logged against the device, or against the I/O card that occurred at approximately the same time as this error. Continue the service action by using these system reference codes.

**Parent topic:** [I/O processor \(IOP\) isolation procedures](#)

---

## IOPIP28

You were sent to this procedure from unit reference code (URC) 9052.

If the failing item is in a migrated tower, use the *(Migrated Expansion Tower Problem Analysis, Repair and Parts)* manual on the V5R1 Supplemental Manuals web site to fix the problem. Otherwise, contact your next

level of support for assistance.

**Parent topic:** [I/O processor \(IOP\) isolation procedures](#)

---

## IOPIP29

The failing item is in a migrated tower.

You were sent to this procedure from URC 9012.

Perform SDIOP-PIP29 in the *(Migrated Expansion Tower Problem Analysis, Repair and Parts)* manual on the V5R1 Supplemental Manuals web site.

**Parent topic:** [I/O processor \(IOP\) isolation procedures](#)

---

## IOPIP30

Use this procedure to correct the problem when the system cannot find the required cache data for the attached disk units.

You were sent to this procedure from URC 9050.

1. If the system has logical partitions, perform this procedure from the logical partition that reported the problem. To determine if the system has logical partitions, go to [Determining if the system has logical partitions](#) before continuing with this procedure.
2. Did you just exchange the storage input/output (I/O) adapter as a result of a failure?
  - ◆ **No:** Continue with step [13](#).
  - ◆ **Yes:** Continue with the next step.
3. Are you working with a 571F/575B card set?
  - ◆ **No:** Go to step [5](#).
  - ◆ **Yes:** Continue with the next step.
4. Remove the 571F/575B card set. Create a new card set with the following:

**Note:** Label all parts (both original and new) before moving them.

- ◆ The **new** replacement 571F storage IOA.
  - ◆ The cache directory card from the **original** 571F storage IOA.
  - ◆ The **original** 575B auxiliary cache adapter.
- See [Separating the 571F/575B card set and moving the cache directory card](#).
- ◆ Ensure that the SCSI cable and the battery power cable on the top edge of the storage side of the card are connected to the top edge of the auxiliary cache side of the card.
  - ◆ Reinstall this card set into the system and go to step [6](#).
5. Remove the I/O adapter. Install the new replacement storage I/O adapter with the following parts installed on it:

**Note:** Label all parts (both old and new) before moving them.

- ◆ The cache directory card from the **original** storage I/O adapter. On adapters with removable cache cards, the cache directory card will move with the removable cache card.
  - ◆ The removable cache card from the **original** storage I/O adapter (this applies to only the 571E and some 2780 I/O adapters).
- See [Removing and replacing parts on type 2748, 2757, 2763, 2778, 2780, 2782, 4758, 4764, 5703, 5708, 5709, 571B, 571E, 571F, 573D, 574F, 575B](#).
- ◆ If the I/O adapter is attached to an auxiliary cache I/O adapter, ensure that the SCSI cable on the last port of the new replacement storage I/O adapter is connected to the auxiliary cache I/O adapter. For a list of auxiliary cache I/O adapters, see [System parts](#).
6. Did the 9050 SRC that sent you to this procedure occur on a type-D IPL?
    - ◆ **Yes:** Perform a type-D IPL and continue with the next step.
    - ◆ **No:** Continue with the next step.
  7. Has a new 9010 or 9050 SRC occurred in the Service Action Log or Product Activity Log?
    - ◆ **No:** Go to step [10](#).
    - ◆ **Yes:** Continue with the next step.
  8. Was the new SRC 9050?
    - ◆ **No:** Continue with the next step.
    - ◆ **Yes:** Contact your next level of support. **This ends the procedure.**
  9. The new SRC was 9010. Reclaim the cache storage. See [Reclaiming IOP cache storage](#).

**Note:** When an auxiliary cache I/O adapter that is connected to the storage I/O adapter logs a 9055 SRC in the Product Activity Log, the reclaim does not result in lost sectors. Otherwise, the reclaim does result in lost sectors, and the system operator might want to restore data from the most recent saved tape after you complete the repair.

10. Are you working with a 571F/575B card set?
  - ◆ **No:** Go to step [12](#).
  - ◆ **Yes:** Continue with the next step.
11. Remove the 571F/575B card set. Create a new card set with the following:
  - ◆ The **new** 571F storage IOA
  - ◆ The cache directory card from the **new** 571F storage IOA
  - ◆ The **new** 575B auxiliary cache adapter

See [Separating the 571F/575B card set and moving the cache directory card](#).

  - ◆ Ensure that the SCSI cable and the battery power cable on the top edge of the storage side of the card are connected to the top edge of the auxiliary cache side of the card.
  - ◆ Reinstall this card set into the system. **This ends the procedure.**
12. Remove the I/O adapter. Install the **new** replacement storage I/O adapter that has the following parts installed on it:
  - ◆ The cache directory card from the **new** storage I/O adapter. On adapters with removable cache cards, the cache directory card will move with the removable cache card.
  - ◆ The removable cache card from the **new** storage I/O adapter (this applies to only the 571E and some 2780 I/O adapters).

See [Removing and replacing parts on type 2748, 2757, 2763, 2778, 2780, 2782, 4758, 4764, 5703, 5708, 5709, 571B, 571E, 571F, 573D, 574F, 575B](#).

  - ◆ If the I/O adapter is attached to an auxiliary cache I/O adapter, ensure that the SCSI cable on the last port of the new replacement storage I/O adapter is connected to the auxiliary cache I/O adapter. For a list of auxiliary cache I/O adapters, see [System parts](#).

**This ends the procedure**
13. Identify the affected disk units using information in the Product Activity Log. Access SST/DST by doing one of the following:
  - ◆ If you can enter a command at the console, access system service tools (SST). See [System Service Tools \(SST\)](#).
  - ◆ If you cannot enter a command at the console, perform an IPL to DST. See [Performing an IPL to DST](#).
  - ◆ If you cannot perform a type A or B IPL, perform a type D IPL from removable media.
14. Did you perform a D IPL to get to DST?
  - ◆ **Yes:** Continue with the next step.
  - ◆ **No:** Perform the following steps:
    - a. Access the Product Activity Log and display the SRC that sent you here, then view *Additional Information* to record the formatted log information. The *Device Errors detected* field indicates the total number of disk units that are affected. The *Device Errors logged* field indicates the number of disk units for which detailed information is

provided. Under the *Device* heading, the unit address, type, and serial number are provided for up to three disk units. Additionally, the controller type and serial number for each of these disk units indicates the adapter to which the disk was last attached when it was operational.

**Note:** You might find more than one Product Activity Log entry with the same Log ID. Access any additional entries by pressing Enter from the Display Detail Report for Resource screen. View *Additional Information* for each entry, and record the formatted log information. For example: You might find an entry for an xxxx902F SRC in the Product Activity Log when the array includes more than 10 disk units.

b. Continue with step 16.

15. A formatted display of hexadecimal information for Product Activity Log entries is not available. To interpret the hexadecimal information, see [More information from hexadecimal reports](#). The *Device Errors detected* field indicates the total number of disk units that are affected. The *Device Errors logged* field indicates the number of disk units for which detailed information is provided. Under the *Device* heading, the unit address, type, and serial number are provided for up to three disk units. Additionally, the controller type and serial number for each of these disk units indicates the adapter to which the disk was last attached when it was operational.

**Note:** You might find an entry for an xxxx902F SRC entry in the Product Activity Log when the array includes more than 10 disk units. To interpret the hexadecimal information for these additional disk units, see [More information from hexadecimal reports](#).

16. Has the I/O card or have the devices been repaired or reconfigured recently?
- ◆ **Yes:** Continue with the next step.
  - ◆ **No:** Contact your next level of support for assistance. **This ends the procedure.**
17. You can use one of the following repair options to correct the problem:
- ◆ Reunite the adapter and disk units identified in previous steps so that the cache data can be written to the disk units. If you can find the devices and adapters and want to continue with this repair option, then continue with the next step.
  - ◆ If the data for the disk units identified in previous steps is not needed on this or any other system, initialize and format these disk units.

**Attention:** This repair option causes a loss of customer data. If you want to continue with this repair option, go to step 19.

18. Perform the following:
- a. Restore the adapter and disk units back to their original configuration. For more information, see [Removing and replacing parts](#). After the system writes cache data to the disk units and you power off the system normally, you can move the adapter and disk units to another location.
  - b. Power on the system. For more information, see [Powering on and powering off](#). Does the IP complete successfully?
    - ◇ **No:** Go to [Start of call procedure](#). **This ends the procedure.**
    - ◇ **Yes:** **This ends the procedure.**
19. You have chosen to initialize and format the identified disk units. Perform the following steps:

**Attention:** Performing the following steps causes a loss of customer data.

- a. If you are not already using dedicated service tools, perform an IPL to DST. For more information, see [Performing an IPL to DST](#). If you cannot perform a type A or B IPL, perform a type D IPL from removable media.
- b. Select Work with disk units. Did you get to DST with a Type D IPL?
  - ◇ **Yes:** Continue with the next step.

- ◇ **No:** Select Work with disk unit recovery > Disk unit problem recovery procedures, then continue with the next step.

20. Select **Initialize and format disk unit**.
21. Follow the online instructions to format and initialize the disk units.
22. Perform an IPL from disk. Does the IPL complete successfully?
  - ◆ **No:** Go to [Start of call procedure](#). **This ends the procedure.**
  - ◆ **Yes:** **This ends the procedure.**

Parent topic: [I/O processor \(IOP\) isolation procedures](#)

---

## Separating the 571F/575B card set and moving the cache directory card

To complete this procedure, you will need a T-10 TORX bit or driver.

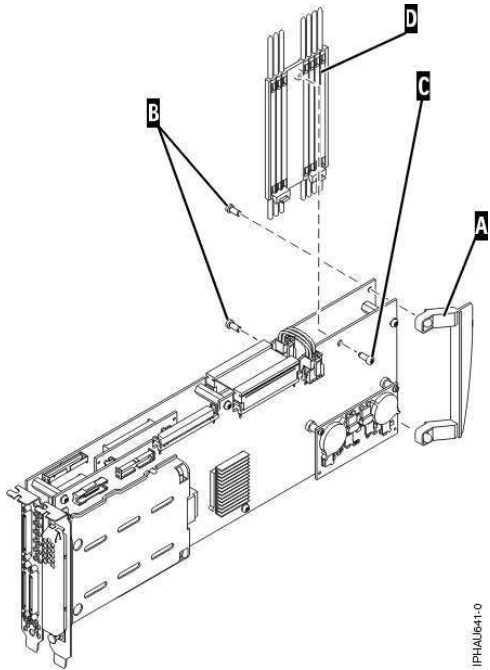
**Attention:** To avoid loss of cache data, you *must not* remove the cache battery during this procedure.

To separate the 571F/575B card set and move the cache directory card, do the following:

**Important:** All cards are sensitive to electrostatic discharge. Read about [Working with electrostatic discharge-sensitive parts](#) before beginning this procedure.

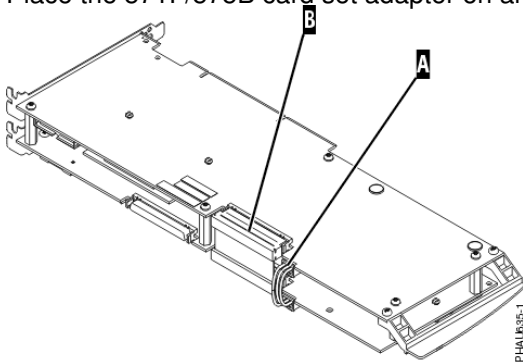
**Note:** If you are removing the adapter from a double-wide cassette, go to [Remove an adapter from the PCI adapter double-wide cassette](#)

1. Label both sides of the card before separating.
2. Go to the next step if you are not servicing a 571F/575B card set containing a light pipe assembly. If you are servicing a 571F/575B card set that contains a light pipe assembly, you will need to remove the light pipes. To remove the light pipes, do the following:
  - a. Place the 571F/575B card set adapter on an ESD protective surface.
  - b. Remove the light pipe retaining screw **C** from the 571F/575B card set.
  - c. Slide the light pipe assembly **D** from between the 571F/575B cards.
  - d. Put both the screw and the light pipe assembly in a safe place.



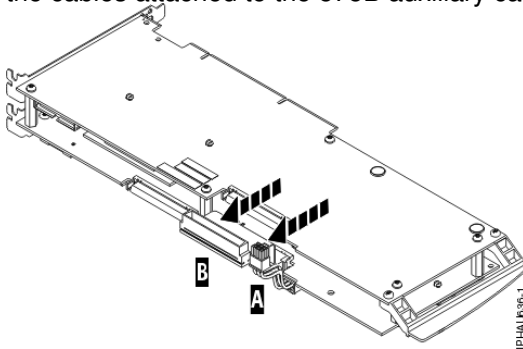
IPHAU841-0

3. Place the 571F/575B card set adapter on an ESD protective surface and orient it as shown.



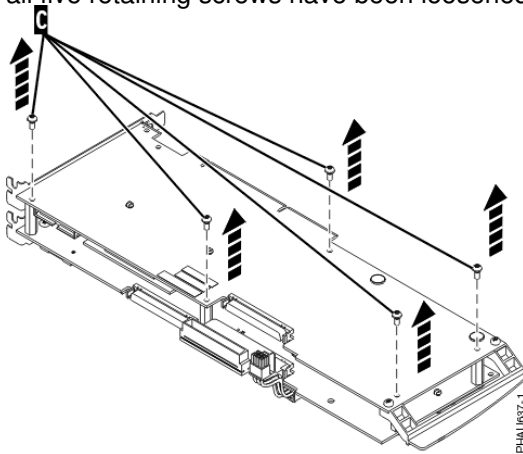
IPHAU835-1

4. Disconnect battery cable A and SCSI cable B from the 571F storage adapter. Leave the other end of the cables attached to the 575B auxiliary cache adapter.



IPHAU836-1

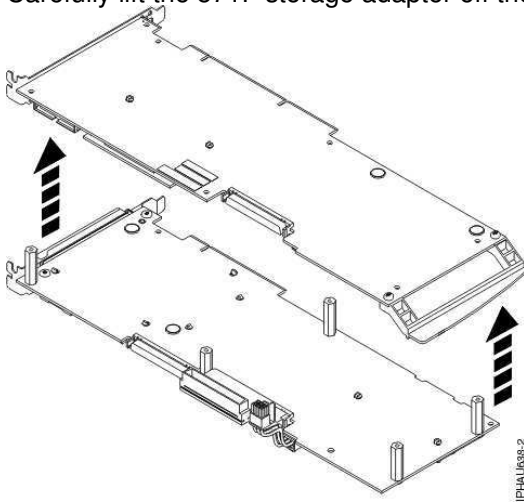
5. To prevent possible card damage, first loosen all 5 retaining screws C BEFORE removing them. After all five retaining screws have been loosened, remove the screws C from the 571F storage adapter.



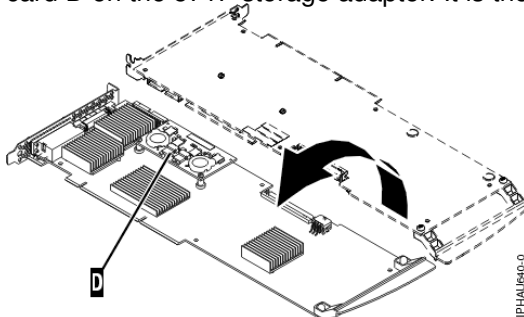
IPHAU837-1



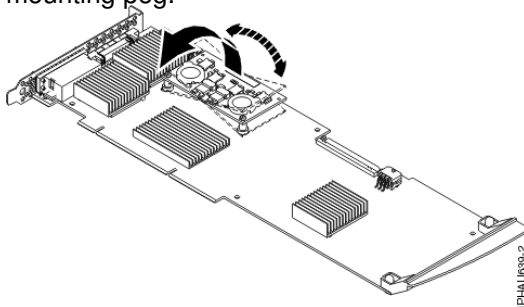
6. Carefully lift the 571F storage adapter off the standoffs and set it on the ESD protective surface.



7. Turn the 571F storage adapter over so the components are facing up and locate the cache directory card D on the 571F storage adapter. It is the small rectangular card mounted on the I/O card.



8. Unseat the connector on the cache directory card by wiggling the two corners that are farthest from the mounting pegs. To disengage the mounting pegs, pivot the cache directory card back over the mounting peg.

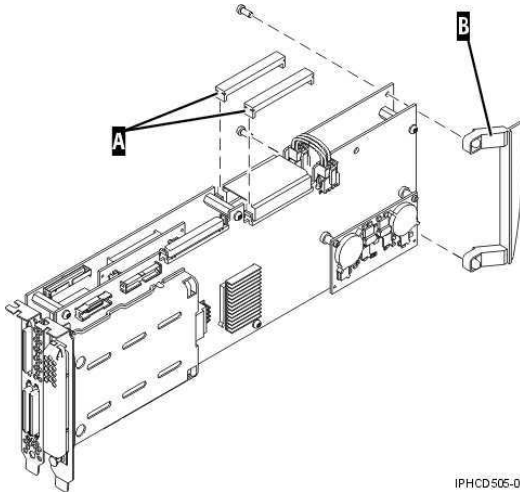


9. Move the cache directory card to the replacement 571F storage adapter and seat it on the connector and mounting pegs.
10. To reassemble the cards do the above procedure in reverse order. To prevent possible card damage, insert all 5 screws C before tightening any of them.

**Note:** If you are installing the 571F/575B card set adapter into a cassette, do the following:

- a. Remove the adapter handle **B** as shown in the following illustration.
- b. If applicable, remove the light-pipe assembly.
- c. Remove the two plastic covers from the SCSI jumper cable **A** as shown in the following figure:

Service provider information



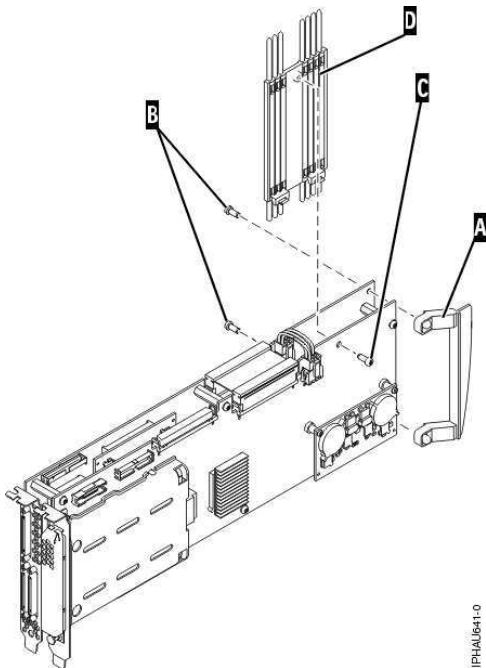
IPHCD505-0

- d. Ensure that battery cable A and SCSI cable B are reconnected to the 575B auxiliary cache adapter.
- e. Go to [Place an adapter in the PCI adapter double-wide cassette](#) to complete the installation.

11. If applicable, to replace the light pipes, do the following:
  - a. Ensure that the 571F/575B cards are correctly assembled.
  - b. If necessary, remove the 571F/575B card handle **A** from the back of the card set.

**Tip:** If you misplace the light-pipe retaining screw **C**, use either of the screws that secure the card handle **B** to the card.

- c. Slide the light pipe assembly **D** between the 571F/575B cards. Ensure that the threaded screw hole located on the light pipe assembly is aligned with the screw clearance hole located on the card .



IPHUB41-0

12. Return to the procedure that sent you here. **This ends this procedure.**

**Parent topic:** [Removing and replacing parts on type 2748, 2757, 2763, 2778, 2780, 2782, 4758, 4764, 5703, 5708, 5709, 571B, 571E, 571F, 573D, 574F, 575B](#)

## IOPIP31

Cache data associated with the attached devices cannot be found.

You were sent to this procedure from URC 9010.

1. If the system has logical partitions, perform this procedure from the logical partition that reported the problem. To determine if the system has logical partitions, go to [Determining if the system has logical partitions](#) before continuing with this procedure.
2. Has the system been powered off for several days?
  - ◆ **No:** Go to step 4.
  - ◆ **Yes:** The cache battery pack may be depleted. Do NOT replace the I/O adapter or the cache battery pack. Reclaim the cache storage. See [Reclaiming IOP cache storage](#). Then continue with the next step.

**Note:** When an auxiliary cache I/O adapter connected to the storage I/O adapter logs a 9055 SRC in the Product Activity Log, the Reclaim does not result in lost sectors. Otherwise, the Reclaim does result in lost sectors, and the system operator may want to restore data from the most recent saved tape after you complete the repair.

3. Does the IPL complete successfully?
  - ◆ **No:** Contact your next level of support. **This ends the procedure.**
  - ◆ **Yes: This ends the procedure.**
4. Are you working with a 571F/575B card set?
  - ◆ **No:** Go to step 6.
  - ◆ **Yes:** Continue with the next step.
5. Remove the 571F/575B card set. Create a new card set with the following:

**Note:** Label all parts (both original and new) before moving them.

- ◆ The **new** replacement 571F storage IOA
- ◆ The cache directory card from the **original** 571F storage IOA
- ◆ The **original** 575B auxiliary cache adapter

See [Separating the 571F/575B card set and moving the cache directory card](#).

- ◆ Ensure that the SCSI cable and the battery power cable on the top edge of the storage side of the card are connected to the top edge of the auxiliary cache side of the card.
  - ◆ Reinstall this card set into the system and go to step 7.
6. Remove the I/O adapter. Install the new replacement storage I/O adapter with the following parts installed on it:
    - ◆ The cache directory card from the **original** storage I/O adapter. On adapters with removable cache cards, the cache directory card will move with the removable cache card.
    - ◆ The removable cache card from the **original** storage I/O adapter (this applies to only the 571E and some 2780 I/O adapters).

See [Removing and replacing parts on type 2748, 2757, 2763, 2778, 2780, 2782, 4758, 4764, 5703, 5708, 5709, 571B, 571E, 571F, 573D, 574F, 575B](#).

    - ◆ If the I/O adapter is attached to an auxiliary cache I/O adapter, ensure that the SCSI cable on the last port of the new replacement storage I/O adapter is connected to the auxiliary cache I/O adapter. For a list of auxiliary cache I/O adapters, see [System parts](#).
  7. Did the 9010 SRC that sent you to this procedure occur on a type-D IPL?

- ◆ **No:** Continue with the next step.
  - ◆ **Yes:** Perform a type-D IPL and continue with the next step.
8. Has a new 9010 or 9050 SRC occurred in the Service Action Log?
- ◆ **No:** Go to step [11](#).
  - ◆ **Yes:** Continue with the next step.
9. Was the new SRC 9050?
- ◆ **No:** Continue with the next step.
  - ◆ **Yes:** Contact your next level of support. **This ends the procedure.**
10. The new SRC was 9010. Reclaim the cache storage. See [Reclaiming IOP cache storage](#).

**Note:** When an auxiliary cache I/O adapter that is connected to the storage I/O adapter logs a 9055 SRC in the Product Activity Log, the reclaim does not result in lost sectors. Otherwise, the reclaim does result in lost sectors, and the system operator might want to restore data from the most recent saved tape after you complete the repair.

11. Are you working with a 571F/575B card set?
- ◆ **No:** Go to step [13](#).
  - ◆ **Yes:** Continue with the next step.
12. Remove the 571F/575B card set. Create a new card set with the following:
- ◆ The **new** 571F storage IOA
  - ◆ The cache directory card from the **new** 571F storage IOA
  - ◆ The **new** 575B auxiliary cache adapter
- See [Separating the 571F/575B card set and moving the cache directory card](#).
- ◆ Ensure that the SCSI cable and the battery power cable on the top edge of the storage side of the card are connected to the top edge of the auxiliary cache side of the card.
  - ◆ Reinstall this card set into the system.
- This ends the procedure.**
13. Remove the I/O adapter. Install the **new** replacement storage I/O adapter that has the following parts installed on it:
- ◆ The cache directory card from the **new** storage I/O adapter. On adapters with removable cache cards, the cache directory card will move with the removable cache card.
  - ◆ The removable cache card from the **new** storage I/O adapter (this applies to only the 571E and some 2780 I/O adapters).
- See [Removing and replacing parts on type 2748, 2757, 2763, 2778, 2780, 2782, 4758, 4764, 5703, 5708, 5709, 571B, 571E, 571F, 573D, 574F, 575B](#).
- ◆ If the I/O adapter is attached to an auxiliary cache I/O adapter, ensure that the SCSI cable on the last port of the new replacement storage I/O adapter is connected to the auxiliary cache I/O adapter. For a list of auxiliary cache I/O adapters, see the [System parts](#).
- This ends the procedure**

Parent topic: [I/O processor \(IOP\) isolation procedures](#)

---

## IOIP32

You were sent to this procedure from unit reference code (URC) 9011.

**Attention:** There is data in the cache of this I/O card, that belongs to devices other than those that are attached. Customer data may be lost.

1. If the system has logical partitions, perform this procedure from the logical partition that reported the problem. To determine if the system has logical partitions, go to [Determining if the system has logical partitions](#) before continuing with this procedure.
2. Did you just exchange the storage I/O adapter as a result of a failure?
  - ◆ **No:** Continue with the next step.

- ◆ Yes: Reclaim the cache storage. See [Reclaiming IOP cache storage](#).

Does the IPL complete successfully?

- ◇ No: Go to [Start of call procedure](#). This ends the procedure.
- ◇ Yes: This ends the procedure.

3. Have the I/O cards been moved or reconfigured recently?

- ◆ No: Ask your next level of support for assistance. This ends the procedure.
- ◆ Yes: Perform the following steps:
  - a. Power off the system. See [Powering on and powering off](#) for details.
  - b. Restore all I/O cards to their original position.
  - c. Select the IPL type and mode that are used by the customer.
  - d. Power on the system.

Does the IPL complete successfully?

- No: Ask your next level of support for assistance. This ends the procedure.
- Yes: This ends the procedure.

**Parent topic:** [I/O processor \(IOP\) isolation procedures](#)

---

## IOPIP33

The I/O processor card detected a device configuration error. The configuration sectors on the device may be incompatible with the current I/O processor card.

You were sent to this procedure from unit reference code (URC) 9001.

1. If the system has logical partitions, perform this procedure from the logical partition that reported the problem. To determine if the system has logical partitions, go to (Determine if the system has logical partitions) before continuing with this procedure.
2. Has the I/O adapter been replaced with a different type of I/O adapter, or have the devices been moved from a different type of I/O adapter to this one?
  - ◆ No: Contact your next level of support. This ends the procedure.
  - ◆ Yes: Continue with the next step.
3. Does the disk unit contain data that needs to be saved?
  - ◆ Yes: Continue with the next step.
  - ◆ No: Initialize and format the disk units.

Attention: Any data on the disk unit will be lost.

Perform the following:

- a. Access SST or DST.
  - b. Select Work with disk units.
  - c. Did you get to DST with a type D IPL?
    - ◇ No: Select Work with disk unit recovery > Disk unit problem recovery procedures. Then, continue with the next step.
    - ◇ Yes: Continue with the next step.
  - d. Select Initialize and format disk unit for each disk unit. When the new disk unit is initialized and formatted, the display will show that the status is complete. This may take 30 minutes or longer.
  - e. The disk unit is now ready to be added to the system configuration. This ends the procedure.
4. The disk unit contains data that needs to be saved.
    - ◆ If the I/O adapter has been replaced with a different type of I/O adapter, reinstall the original I/O adapter. Then continue with the next step.
    - ◆ If the disk units have been moved from a different type of I/O adapter to this one, return the disk units to their original I/O adapter. Then continue with the next step.
  5. Stop parity protection on the disk units, and power down the system normally with the I/O adapter in an operational state. The I/O adapter or disk units can now be returned to the configuration at the beginning of this procedure. This ends the procedure.

## IOPIP34

You were sent to this procedure from unit reference code (URC) 9027.

The I/O processor card detected that an array is not functional due to the present hardware configuration.

1. If the system has logical partitions, perform this procedure from the logical partition that reported the problem. To determine if the system has logical partitions, go to (Determine if the system has logical partitions) before continuing with this procedure.
2. Has the I/O adapter been replaced with a different I/O adapter, or have the devices been moved from a different I/O adapter to this one?
  - ◆ No: Perform (IOPIP22). This ends the procedure.
  - ◆ Yes: Perform the following:
    - a. Power off the system. See (Power on/off the system and logical partitions).
    - b. Restore all I/O cards or devices to their original position.
    - c. Power on the system.
3. Does the IPL complete successfully?
  - ◆ No: Ask your next level of support for assistance. This ends the procedure.
  - ◆ Yes: This ends the procedure.

## IOPIP40

Use this procedure to isolate the problem when a storage I/O adapter is connected to an incompatible or non-operational auxiliary cache I/O adapter.

Perform the following:

1. Are you working on a 571F/575B combination storage and auxiliary cache IOA card set (uses two card slot locations)?
  - ◆ **Yes:** Continue with step 2.
  - ◆ **No:** Continue with step 3.
2. Find the location of the card.
  - ◆ Use the location displayed in the Service Action Log. If the Service Action Log does not have a location, determine the address of the I/O adapter. See [System reference code \(SRC\) address formats](#).
  - ◆ The location identified is for the 571F side of the card set.  
You must configure both the 571F and the 575B in the same partition. Are both the 571F side of the card set and the 575B side of the card set configured in the same partition?
    - ◆ **Yes:** Replace the entire card set. See [Finding part locations](#) for the model you are working on. **This ends the procedure.**
    - ◆ **No:** Change the configuration so that the same partition controls both cards in the card set. **This ends the procedure.**
3. Ensure that the SCSI cable on the last port of the storage I/O adapter is connected to the auxiliary cache I/O adapter. Do the following:
  - a. Use the location of the storage I/O adapter displayed in the Service Action Log. If the Service Action Log does not have a location, determine the address of the storage I/O adapter. See [System reference code \(SRC\) address formats](#).
  - b. Determine the location of the storage I/O adapter. See [Finding part locations](#) for the model you are working on.
  - c. Ensure that the SCSI cable on the last port of the storage I/O adapter is properly connected to an auxiliary cache I/O adapter.

- d. Ensure that both the auxiliary cache I/O adapter and the storage I/O adapter are in the same partition.
- e. Ensure that the slot power indicator is lit for the auxiliary cache I/O adapter. If it is not, use concurrent maintenance to power on the slot.
4. Ensure that the auxiliary cache I/O adapter is supported for the storage I/O adapter to which it is connected. See [PCI adapter](#) installation instructions for information about which adapters are compatible.
5. Replace the SCSI cable on the last port of the storage I/O adapter that connects to the auxiliary cache I/O adapter. See [Part number catalog](#) for cable part number information. If this does not fix the problem, replace the auxiliary cache I/O adapter. **This ends the procedure.**

**Parent topic:** [I/O processor \(IOP\) isolation procedures](#)

---

## IOPIP41

Use this procedure to correct the problem when an auxiliary cache I/O adapter is not connected to a storage I/O adapter or when an auxiliary cache I/O adapter is connected to an incompatible or non-operational storage I/O adapter.

Perform the following:

1. Are you working on a 571F/575B combination storage and auxiliary cache IOA card set (uses two card slot locations)?
  - ◆ **Yes:** Continue with step 2.
  - ◆ **No:** Continue with step 3.
2. Find the location of the card.
  - ◆ Use the location displayed in the Service Action Log. If the Service Action Log does not have a location, determine the address of the I/O adapter. See [System reference code \(SRC\) address formats](#).
  - ◆ The location identified is for the 575B side of the card set.  
You must configure both the 571F and the 575B in the same partition. Are both the 571F side of the card set and the 575B side of the card set configured in the same partition?
    - ◆ **Yes:** Replace the entire card set. See [Finding part locations](#) for the model you are working on. **This ends the procedure.**
    - ◆ **No:** Change the configuration so that the same partition controls both cards in the card set. **This ends the procedure.**
3. Ensure that the SCSI cable of the auxiliary cache I/O adapter is connected to the last port of the storage I/O adapter. Do the following:
  - a. Use the location of the auxiliary cache I/O adapter displayed in the Service Action Log. If the Service Action Log does not have a location, determine the address of the auxiliary cache I/O adapter. See [System reference code \(SRC\) address formats](#).
  - b. Determine the location of the auxiliary cache I/O adapter. See [Finding part locations](#) for the model you are working on.
  - c. Ensure that the SCSI cable of the auxiliary cache I/O adapter is properly connected to the last port of the storage I/O adapter.
  - d. Ensure that both the auxiliary cache I/O adapter and the storage I/O adapter are in the same partition.
  - e. Ensure that the slot power indicator is lit for the storage I/O adapter. If it is not, use concurrent maintenance to power on the slot.
4. Did you just replace the auxiliary cache I/O adapter because of a failure and did the new replacement auxiliary cache I/O adapter log a 9073 URC?
  - ◆ **Yes:** The SCSI bus on the storage I/O adapter may be disabled as a result of the initial failure. Use Hardware Service Manager to re-IPL the storage I/O adapter that is connected to the new replacement auxiliary cache I/O adapter. **This ends the procedure.**
  - ◆ **No:** Continue with the next step.
5. Ensure that the auxiliary cache I/O adapter is supported for the storage I/O adapter to which it is connected. See [PCI adapter](#) installation instructions for information about which adapters are compatible.
6. Replace the SCSI cable that connects the auxiliary cache I/O adapter to the storage I/O adapter. See [Part number catalog](#) for cable part number information. If this does not fix the problem, replace the storage I/O adapter. **This ends the procedure.**

## Licensed internal code (LIC) isolation procedures

Use this section to isolate licensed internal code (LIC) problems.

Please read and observe all safety procedures before servicing the system and while performing a procedure.

**Attention:** Unless instructed otherwise, always power off the system or expansion tower where the FRU is located, (see [Powering on and powering off](#)) before removing, exchanging, or installing a field-replaceable unit (FRU).

### **DANGER**When working on or around the system, observe the following precautions:

Electrical voltage and current from power, telephone, and communication cables are hazardous. To avoid a shock hazard:

- Connect power to this unit only with the provided power cord. Do not use the provided power cord for any other product.
- Do not open or service any power supply assembly.
- Do not connect or disconnect any cables or perform installation, maintenance, or reconfiguration of this product during an electrical storm.
- The product might be equipped with multiple power cords. To remove all hazardous voltages, disconnect all power cords.
- Connect all power cords to a properly wired and grounded electrical outlet. Ensure that the outlet supplies proper voltage and phase rotation according to the system rating plate.
- Connect any equipment that will be attached to this product to properly wired outlets.
- When possible, use one hand only to connect or disconnect signal cables.
- Never turn on any equipment when there is evidence of fire, water, or structural damage.
- Disconnect the attached power cords, telecommunications systems, networks, and modems before you open the device covers, unless instructed otherwise in the installation and configuration procedures.
- Connect and disconnect cables as described in the following procedures when installing, moving, or opening covers on this product or attached devices.
  - To Disconnect:
    1. Turn off everything (unless instructed otherwise).
    2. Remove the power cords from the outlets.
    3. Remove the signal cables from the connectors.
    4. Remove all cables from the devices

To Connect:

1. Turn off everything (unless instructed otherwise).
2. Attach all cables to the devices.
3. Attach the signal cables to the connectors.
4. Attach the power cords to the outlets.
5. Turn on the devices.

(D005)

- **LICIP01**  
Licensed Internal Code detected an IOP programming problem.
- **LICIP03**  
Dedicated service tools (DST) found a permanent program error, or a hardware failure occurred.
- **LICIP04**  
The initial program load (IPL) service function ended.
- **LICIP07**  
The system detected a problem while communicating with a specific I/O processor.



- **LICIP08**  
Licensed Internal Code detected an operating system program problem.
- **LICIP11**  
Use this procedure to isolate a system STARTUP failure in the initial program load (IPL) mode.
- **LICIP12**  
Use this procedure to isolate an Independent Auxiliary Storage Pool (IASP) vary on failure.
- **LICIP13**  
A disk unit seems to have stopped communicating with the system.
- **LICIP14**  
Licensed Internal Code detected a card slot test failure.
- **LICIP15**  
Use this procedure to help you recover from an initial program load (IPL) failure.

Parent topic: [Isolation procedures](#)

---

## LICIP01

Licensed Internal Code detected an IOP programming problem.

You will need to gather data to determine the cause of the problem. If using OptiConnect, and the IOP is connected to another system, then collect this information from both systems. Read the [Licensed internal code \(LIC\) isolation procedures](#) before continuing with this procedure.

1. If the system has logical partitions, perform this procedure from the logical partition that reported the problem. To determine if the system has logical partitions, go to [Determining if the system has logical partitions](#) before continuing with this procedure.
2. Is the system operational: Did the SRC come from the Service Action Log, Product Activity Log, problem log, or system operator message?
  - ◆ **No:** Go to step [9](#).
  - ◆ **Yes:** Is this a x6xx5121 SRC?
    - ◇ **No:** Continue with the next step.
    - ◇ **Yes:** Go to step [4](#).
3. If the IOP has DASD attached to it, then the IOP dump is in SID87 (or SID187 if the DASD is mirrored). Copy the IOP dump. See [Working with storage dumps](#).
4. Print the Product Activity Log, including any IOP dumps, to removable media for the day which the problem occurred. Select the option to obtain HEX data.
5. Use the "Licensed Internal Code log" service function under DST/SST to copy the LIC log entries to removable media for the day that the problem occurred.
6. Copy the system configuration list. See [Printing the System Configuration List](#).
7. Provide the dumps to Service Support.
8. Check the Logical Hardware Resource STATUS field using Hardware Service Manager. If the status is not *Operational* then IPL the IOP using the I/O Debug option. Ignore resources with a status of *not connected*.

To IPL a failed IOP, the following command can be used: `VRYCFG CFGOBJ (XXXX) CFGTYPE (*CTL) STATUS (*RESET)` or use DST/SST Hardware Service Manager.

If the IPL does not work:

- ◆ Check the Service Action Log for new SRC entries. See [Using the Service Action Log](#). Use the new SRC and go to the [Reference codes](#) topic.
  - ◆ If there are no new SRCs in the Service Action Log, go to [Start of call procedure](#). **This ends the procedure.**
9. Has the system stopped but the DST console is still active: Did the SRC come from the Main Storage Dump manager screen on the DST console?
    - ◆ **Yes:** Continue with the next step.
    - ◆ **No:** Go to step [15](#).
  10. Complete a Problem Summary Form using the information in words 1-9 from the control panel, or from the DST Main Storage Dump screen.
  11. The system has already taken a partial main storage dump for this SRC and automatically re-IPLed to DST.

12. Copy the main storage dump to tape. See [Working with storage dumps](#).
13. When the dump is completed, the system will re-IPL automatically. Sign on to DST or SST. Obtain the data in steps 3, 4, 5, and 6.
14. Provide the dumps to Service Support. **This ends the procedure.**
15. Has the system stopped with an SRC at the control panel?
  - ◆ **Yes:** Continue with the next step.
  - ◆ **No:** Go to step 2.
16. Complete a Problem Summary Form using the information in words 1-9 from the control panel, or from the DST Main storage dump screen.
17. Do **NOT** power off the system. Perform a manual IPL to DST, and start the Main storage dump manager service function.
18. Copy the main storage dump to tape.
19. Obtain the data in steps 3, 4, 5, and 6.
20. Re-IPL the system.
21. Has the system stopped with an SRC at the control panel?
  - ◆ **Yes:** Use the new SRC and go to the [Reference codes](#) topic. **This ends the procedure.**
  - ◆ **No:** Provide the dumps to Service Support. **This ends the procedure.**

Parent topic: [Licensed internal code \(LIC\) isolation procedures](#)

---

## LICIP03

Dedicated service tools (DST) found a permanent program error, or a hardware failure occurred.

Read the danger notices in the [Licensed internal code \(LIC\) isolation procedures](#) before continuing with this procedure.

1. If the system has logical partitions, perform this procedure from the logical partition that reported the problem. To determine if the system has logical partitions, go to [Determining if the system has logical partitions](#) before continuing with this procedure.
  2. Does URC 50FF occur?
    - ◆ No: Continue with the next step.
    - ◆ Yes: Go to step 4.
  3. Perform a main storage dump, then perform an IPL by doing the following:
    - a. Perform a main storage dump. See [Working with storage dumps](#).
    - b. Select Manual mode and perform an IPL to DST. See [Performing an IPL to DST](#).
    - c. When the IPL has completed, the system console should be at the DST display. Go to step 7. If the DST display does not appear on the system console, contact your next level of support.
  4. Perform a main storage dump, then perform an IPL by doing the following:
    - a. Perform a main storage dump. See [Working with storage dumps](#).
    - b. Select Manual mode and perform an IPL to DST. See [Performing an IPL to DST](#).

Does a display appear?

    - ◆ No: Continue with the next step.
    - ◆ Yes: Go to step 7.
  5. If the problem is in the logical partition, exchange the first workstation I/O processor card on bus 1. See [Removing and replacing parts](#).
  6. Select Manual mode and perform an IPL to DST. See [Performing an IPL to DST](#).
- Is the IPL or Install the System display shown?
- ◆ Yes: Continue with the next step.
  - ◆ No: Ask your next level of support for assistance and report the problem. This ends the procedure.
7. Copy the main storage dump to removable media. See [Working with storage dumps](#).
  8. Report a Licensed Internal Code problem to your next level of support. This ends the procedure.

Parent topic: [Licensed internal code \(LIC\) isolation procedures](#)

---

## LICIP04

The initial program load (IPL) service function ended.

Dedicated service tools (DST) was in the disconnected status or lost communications with the IPL console because of a console failure and could not communicate with the user. Read the danger notices in [Licensed internal code \(LIC\) isolation procedures](#) before continuing with this procedure.

1. If the system has logical partitions, perform this procedure from the logical partition that reported the problem. To determine if the system has logical partitions, go to [Determining if the system has logical partitions](#) before continuing with this procedure.
2. Select function 21 (Make DST Available) on the control panel and press Enter to start DST again.

Does the DST Sign On display appear?

- ◆ **No:** Continue with the next step.
- ◆ **Yes:** Perform the following steps (see [Dedicated Service Tools \(DST\)](#) for details):
  - a. Select Start a Service Tool > Licensed Internal Code log.
  - b. Perform a dump of the Licensed Internal Code log to tape. See [Start a service tool](#) for details.
  - c. Return here and continue with the next step.
- 3. Perform a main storage dump. See [Working with storage dumps](#) for details.
- 4. Copy the main storage dump to removable media. See [Working with storage dumps](#) for details.
- 5. Report a Licensed Internal Code problem to your next level of support. **This ends the procedure.**

**Parent topic:** [Licensed internal code \(LIC\) isolation procedures](#)

---

## LICIP07

The system detected a problem while communicating with a specific I/O processor.

The problem could be caused by Licensed Internal Code, the I/O processor card, or by bus hardware. Read the danger notices in [Licensed internal code \(LIC\) isolation procedures](#) before continuing with this procedure.

1. If the system has logical partitions, perform this procedure from the logical partition that reported the problem. To determine if the system has logical partitions, go to [Determining if the system has logical partitions](#) before continuing with this procedure.
2. Did a previous procedure have you power off the system, perform an IPL in Manual mode, and is the system in Manual mode now?
  - ◆ **Yes:** Continue with the next step.
  - ◆ **No:** Perform the following steps:
    - a. Power off the system. See [Powering on and powering off](#) for details.
    - b. Select Manual mode on the control panel. See [IPL type, mode, and speed options](#) for details.
    - c. Power on the system.
    - d. Continue with the next step.
3. Does the SRC that sent you to this procedure appear on the control panel?
  - ◆ **No:** Continue with the next step.
  - ◆ **Yes:** Use the information in the SRC to determine the card direct select address. If the SRC is B6006910, you can use the last 8 characters of the top 16 character line of function 13 (word 7) to find the card direct select address in BBBBCcbb format.

```
BBBB Bus number
Cc Card direct select address
bb board address
```

Go to step [11](#).

4. Does the console display indicate a problem with missing disks?
  - ◆ Yes: Continue with the next step.
  - ◆ No: Go to step 6.
5. Perform the following steps:
  - a. Go to the DST main menu.
  - b. On the DST sign-on display, enter the DST full authority user ID and password. See [Dedicated Service Tools \(DST\)](#) for details.
  - c. Select Start a service tool > Hardware service manager.
  - d. Check for the SRC in the service action log. See [Using the Service Action Log](#).

Did you find the same SRC that sent you to this procedure?

  - ◇ Yes: Note the date and time for that SRC. Go to the Product Activity Log and search all logs to find the same SRC. When you have found the SRC, go to step 9.
  - ◇ No: Perform the following steps:
    - i. Return to the DST main menu.
    - ii. Perform an IPL and return to the Display Missing Disk Units display.
    - iii. Go to [LICIP11](#). This ends the procedure.
6. Does the SRC that sent you to this procedure appear on the console or on the alternative console?
  - ◆ Yes: Continue with the next step.
  - ◆ No: Does the IPL complete successfully to the IPL or Install the System display?
    - ◇ Yes: Continue with the next step.
    - ◇ No: A different SRC occurred. Go to the [Reference codes](#) topic and use the new SRC to correct the problem. This ends the procedure.
7. Perform the following:
  - a. Use the full-authority password to sign on to DST.
  - b. Search *All logs* in the product activity log looking for references of SRC B600 5209 and the SRC that sent you to this procedure.

**Note:** Search only for SRCs that occurred during the last IPL.

Did you find B600 5209 or the same SRC that sent you to this procedure?

- ◆ Yes: Go to step 10.
  - ◆ No: Did you find a different SRC than the one that sent you to this procedure?
    - ◇ Yes: Continue with the next step.
    - ◇ No: The problem appears to be intermittent. Ask your next level of support for assistance. This ends the procedure.
8. Use the new SRC to correct the problem. See the [Reference codes](#) topic. This ends the procedure.
  9. Use F11 to move through alternative views of the log analysis displays until you find the card position and frame ID of the failing IOP associated with the SRC.

Was the card position and frame ID available, and did this information help you find the IOP?

- ◆ No: Continue with the next step.
  - ◆ Yes: Go to step 12.
10. Perform the following steps:
    - a. Display the report for the log entry of the SRC that sent you to this procedure.
    - b. Display the additional information for the entry.
    - c. If the SRC is B6006910, use characters 9-16 of the top 16 character line of function 13 (word 7) to find the card direct select address in BBBBCcbb format.

```

BBBB Bus number
Cc Card direct select address
bb board address
      
```
  11. Use the BBBBCcbb information and refer to [Finding part locations](#) to determine the failing IOP and its location.
  12. Go to [MABIP06](#) to isolate an I/O adapter problem on the IOP you just identified. If this fails to isolate the problem, return here and continue with the next step.
  13. Is the I/O processor card you identified in step 9 or step 11 the CFIOIP?
    - ◆ No: Continue with the next step.
    - ◆ Yes: Perform the following steps:
      - a. Exchange the failing CFIOIP card. See [Removing and replacing parts](#).

**Note:** You will be prompted for the system serial number. Ignore any error messages regarding system configuration that appear during the IPL.

- b. Go to step [16](#).
14. Perform the following steps:
  - a. Power off the system.
  - b. Remove the IOP card.
  - c. Power on the system.

Does the SRC that sent you to this procedure appear on the control panel or appear as a new entry in the service action log or product activity log?

  - ◆ No: Continue with the next step.
  - ◆ Yes: Perform the following steps:
    - a. Power off the system.
    - b. Install the IOP card you just removed.
    - c. Replace the multi-adapter bridge using symbolic FRU [MA\\_BRDG](#). This ends the procedure.
15. Perform the following steps:
  - a. Power off the system.
  - b. Exchange the failing IOP card.
16. Power on the system.

Does the SRC that sent you to this procedure appear on the control panel, on the console, or on the alternative console?

- ◆ No: Continue with the next step.
  - ◆ Yes: Go to step [18](#).
17. Does a different SRC appear on the control panel, on the console, or on the alternative console?
    - ◆ Yes: Go to the [Reference codes](#) topic and use the new SRC to correct the problem. This ends the procedure.
    - ◆ No: On the IPL or Install the System display, check for the SRC in the service action log. See [Using the Service Action Log](#) for details.

Did you find the same SRC that sent you to this procedure?

- ◇ Yes: Continue with the next step.
  - ◇ No: Go to [Verifying a high-speed link, system PCI bus, or a multi-adapter bridge repair](#). This ends the procedure.
18. Perform the following steps:
    - a. Power off the system.
    - b. Remove the IOP card you just exchanged and install the original card.
    - c. Go to (Bus-PIP1). This ends the procedure.
  19. Ask your next level of support for assistance and report a Licensed Internal Code problem. You may be asked to verify that all PTFs have been applied.

If you are asked to perform the following, see the following:

- ◆ Copy the main storage dump from disk to tape or diskette, see [Working with storage dumps](#).
- ◆ Print the product activity log, see [Using the product activity log](#).
- ◆ Copy the IOP storage dump to removable media, see [Working with storage dumps](#). This ends the procedure.

**Parent topic:** [Licensed internal code \(LIC\) isolation procedures](#)

---

## LICIP08

Licensed Internal Code detected an operating system program problem.

Read the danger notices in [Licensed internal code \(LIC\) isolation procedures](#) before continuing with this procedure.

1. If the system has logical partitions, perform this procedure from the logical partition that reported the problem. To determine if the system has logical partitions, go to [Determining if the system has logical partitions](#) before continuing with this procedure.
2. Select Manual mode and perform an IPL to DST. See [Performing an IPL to DST](#).

Does the same SRC occur?

- ◆ Yes: Go to step 5.
- ◆ No: Does the same URC appear on the console?
  - ◇ No: Continue with the next step.
  - ◇ Yes: Go to step 4.

3. Does a different SRC occur, or does a different URC appear on the console?
  - ◆ Yes: Use the new SRC or reference code to correct the problem. See the [Reference codes](#) topic. If the procedure for the new SRC sends you back to this procedure, then continue with the next step. This ends the procedure.
  - ◆ No: Select Perform an IPL on the IPL or Install the System display to complete the IPL.

Is the problem intermittent?

- ◇ Yes: Continue with the next step.
- ◇ No: This ends the procedure.

4. Copy the main storage dump to removable media. See [Working with storage dumps](#).
5. Report a Licensed Internal Code problem to your next level of support. This ends the procedure.

**Parent topic:** [Licensed internal code \(LIC\) isolation procedures](#)

---

## LICIP11

Use this procedure to isolate a system STARTUP failure in the initial program load (IPL) mode.

Ensure you have read the danger notices in [Licensed internal code \(LIC\) isolation procedures](#) before continuing with this procedure.

**Parent topic:** [Licensed internal code \(LIC\) isolation procedures](#)

### How to find the cause code

1. If the system has logical partitions, perform this procedure from the logical partition that reported the problem. To determine if the system has logical partitions, go to [Determining if the system has logical partitions](#).
2. Were you given a cause code by another procedure?
  - ◆ No: Continue with the next step.
  - ◆ Yes: Use the cause code given by the other procedure. Then, go to step 4.
3. Look at the Data display characters in word 3. You can obtain these characters by either:
  - ◆ Looking at word 3 on the Problem summary form that was filled out earlier.
  - ◆ Selecting characters 9-16 of the top 16 character line of function 12 (word 3).
4. The 4 leftmost characters of word 3 represent the cause code. Select the cause code to go to the correct isolation instructions:

|                      |                      |                      |                      |
|----------------------|----------------------|----------------------|----------------------|
| <a href="#">0001</a> | <a href="#">0010</a> | <a href="#">0020</a> | <a href="#">0031</a> |
| <a href="#">0002</a> | <a href="#">0011</a> | <a href="#">0021</a> | <a href="#">0033</a> |
| <a href="#">0004</a> | <a href="#">0012</a> | <a href="#">0022</a> | <a href="#">0034</a> |
| <a href="#">0005</a> | <a href="#">0015</a> | <a href="#">0023</a> | <a href="#">0037</a> |
| <a href="#">0006</a> | <a href="#">0016</a> | <a href="#">0024</a> |                      |
| <a href="#">0007</a> | <a href="#">0017</a> | <a href="#">0025</a> | <a href="#">0099</a> |

|      |      |      |  |
|------|------|------|--|
| 0008 | 0018 | 0026 |  |
| 0009 | 0019 | 0027 |  |
| 000A | 001A |      |  |
| 000B | 001C |      |  |
| 000C | 001D |      |  |
| 000D | 001E |      |  |
| 000E | 001F |      |  |

0001

Disk configuration is missing.

1. Select Manual mode and perform an IPL to DST for the failing partition (see [Performing an IPL to DST](#)). Does the Disk Configuration Error Report display appear?
  - ◆ Yes: Continue with the next step.
  - ◆ No: The IPL completed successfully. This ends the procedure.
2. Is Missing Disk Configuration information displayed?
  - ◆ Yes: Continue with the next step.
  - ◆ No: Go to step 1 for cause code 0002.
3. On the Missing Disk Configuration display, perform the following:
  - a. Select option 5 > Display Detailed Report > Work with disk units > Work with disk unit recovery > Recover Configuration.
  - b. Follow the instructions on the display. After the disk configuration is recovered, the system automatically performs an IPL. This ends the procedure.

0002

Disk units are missing from the disk configuration.

Data from the control panel can be used to find information about the missing disk unit. See [System Reference Code \(SRC\) information](#) for details.

1. Did you enter this procedure because all the devices listed on the Display Missing Units display (reached from the Disk Configuration Error Report, the Disk Configuration Attention Report, or the Disk Configuration Warning Report display) have a reference code of 0000?
  - ◆ No: Continue with the next step.
  - ◆ Yes: Go to step 20.
2. Have you installed a new disk enclosure in a disk unit and not restored the data to the disk unit?
  - ◆ No: Continue with the next step.
  - ◆ Yes: Ignore SRC A600 5090. Continue with the disk unit exchange recovery procedure (see [Copy the contents of the LIC log](#)). This ends the procedure.
3. Use words 1-9 from the information recorded on the Problem summary form to determine the disk unit that is missing from the configuration:
  - ◆ Characters 1-8 of the bottom 16 character line of function 12 (word 4) contain the IOP direct select address.
  - ◆ Characters 1-8 of the top 16 character line of function 13 (word 6) contains the disk unit type, level and model number.
  - ◆ Characters 9-16 of the top 16 character line of function 13 (word 7) contains the disk unit serial number.

**Note:** For 2105 and 2107 disk units, the 5 rightmost characters of word 7 contain the disk unit serial number.

- ◆ Characters 1-8 of the bottom 16 character line of function 13 (word 8) contains the number of missing disk units.

Are the problem disk units 432x, 660x, 671x, or 673x disk units?

- ◆ No: Continue with the next step.
- ◆ Yes: Go to step 5.

4. Attempt to get all devices attached to the MSIOP to Ready status by performing the following:
  - a. The MSIOP address (MSIOP Direct Select Address) to use is characters 1-8 of the bottom 16 character line of function 12 (word 4).
  - b. Verify the following and correct if necessary before continuing with step 10.
    - ◇ All cable connections are made correctly and are tight.
    - ◇ All storage devices have the correct signal bus address, as indicated in the system configuration list.
    - ◇ All storage devices are powered on and ready.
5. Did you enter this procedure because there was an entry in the Service Action Log which has the reference code B6005090?
  - ◆ Yes: Continue with the next step.
  - ◆ No: Go to step 10.
6. Are customer jobs running on the system now?
  - ◆ Yes: Continue with the next step.
  - ◆ No: Ensure that the customer is not running any jobs before continuing with this procedure. Then go to step 10.
7. Select System Service Tools (SST) > Work with disk units > Display disk configuration > Display disk configuration status.

Are any disk units missing from the configuration (indicated by an asterisk \*)?

- ◆ Yes: Continue with the next step.
- ◆ No: This ends the procedure.

8. Do all of the disk units that are missing from the configuration have a status of "Suspended"?
  - ◆ Yes: Continue with the next step.
  - ◆ No: Ensure that the customer is not running any jobs before continuing with this procedure. Then go to step 10.
9. Use the Service Action Log to determine if there are any entries for the missing disk units (see [Using the Service Action Log](#)). Are there any entries in the Service Action Log for the missing disk units that were logged since the last IPL?
  - ◆ Yes: Use the information in the Service Action Log, and go to the SRC information for the specific disk unit (see [Reference codes](#)). Perform the action indicated for the unit reference code. This ends the procedure.
  - ◆ No: Go to step 21.
10. Select Manual mode and perform an IPL to DST for the failing partition (see [Performing an IPL to DST](#)). Does the Disk Configuration Error Report, the Disk Configuration Attention Report, or the Disk Configuration Warning Report display appear?
  - ◆ Yes: Continue with the next step.
  - ◆ No: The IPL completed successfully. This ends the procedure.
11. Does one of the following messages appear in the list?
  - ◆ Missing disk units in the configuration
  - ◆ Missing mirror protected disk units in the configuration
  - ◆ Yes: Continue with the next step.
  - ◆ No: Go to step 16.
12. Select option 5. Do the missing units have device parity protected status? (Device parity protection status is indicated by "DPY/" as the first four characters of the status.)
  - ◆ Yes: Continue with the next step.
  - ◆ No: Go to step 14.
13. Is the status DPY/Active?
  - ◆ Yes: Continue with the next step.
  - ◆ No: Use the Service Action Log to determine if there are any entries for the missing disk units or the IOA/IOP controlling them. See [Using the Service Action Log](#) for details. This ends the procedure.
14. Press F11, and press Enter to display the details.

Do all of the disk units listed on the display have a reference code of 0000?

- ◆ Yes: Continue with the next step.
- ◆ No: Use the disk unit reference code shown on the display and go to the SRC information for the specific disk unit in the [Reference codes](#) topic. Perform the action indicated for the unit



- reference code. This ends the procedure.
15. Do all of the IOPs or devices listed on the display have a reference code of 0000?
    - ◆ No: Use the IOP reference code shown on the display and go to [Reference codes](#). Perform the action indicated for the reference code. This ends the procedure.
    - ◆ Yes: Go to step [20](#).
  16. Does the following message appear in the list: `Unknown load-source status`?
    - ◆ Yes: Continue with the next step.
    - ◆ No: Go to step [18](#).
  17. Select option 5, press F11, and then press Enter to display the details.

Does the Assign Missing Load Source Disk display appear?

- ◆ No: Continue with the next step.
  - ◆ Yes: Press Enter to assign the missing load-source disk unit. This ends the procedure.
18. Does the following message appear in the list?

Load source failure

- ◆ Yes: Continue with the next step.
  - ◆ No: The IPL completed successfully. This ends the procedure.
19. Select option 5, press F11, and then press Enter to display the details.
  20. The number of failing disk unit facilities (actuators) is the number of disk units displayed. A disk unit has a *Unit* number greater than zero.
 

Find the failing disk unit by type, model, serial number, or address displayed on the console.
  21. Is there more than one failing disk device attached to the IOA or MSIOP?
    - ◆ Yes: Continue with the next step.
    - ◆ No: Go to step [24](#).
  22. Use the SAL to determine if there are any entries that occurred around the time of the A6xx/B6xx 5090 SRC (see [Using the Service Action Log](#)). Are there any such entries?
    - ◆ No: Continue with the next step.
    - ◆ Yes: Use the information in the SAL and go to the SRC information for the specific error (see [Reference codes](#)). Perform the action indicated for the unit reference code. This ends the procedure.
  23. Are all the disk devices that are attached to the IOA or MSIOP failing? (If the disk units are using mirrored protection, select Display Disk Status to find out.)
    - ◆ No: Continue with the next step.
    - ◆ Yes: Go to step [25](#).
  24. Go to the service information for the specific disk unit listed below and perform the action indicated. Then return here and answer the question below the listed disk units.
    - ◆ 2105, 2107 disk units: Use SRC 3002 in [\(2105, 2107\) Disk unit reference codes](#) and exchange the FRUs shown one at a time.
    - ◆ 432x, 660x, 671x, 673x disk units: Use SRC 3002 in [\(432x, 660x, 671x, 673x\) Disk unit reference codes](#) and exchange the FRUs shown one at a time.

Did the disk unit service information correct the problem?

    - ◆ No: Continue with the next step.
    - ◆ Yes: This ends the procedure.

25. Exchange the IOA or MSIOP (see [Removing and replacing parts](#)).

If exchanging the IOA or MSIOP did not correct the problem, use the original SRC and exchange the failing items, starting with the highest probable cause of failure. If the failing item list contains FI codes, see [Using failing item codes](#) to help determine parts and locations. This ends the procedure.

0004

Some disk units are unprotected but configured into a mirrored ASP. These units were originally DPY protected but protection was disabled.

Perform the following:

1. Is the system managed by an HMC?

- ◆ Yes: Select DST by performing the HMC action for Function 21 for the failing partition (see [Control panel functions](#) in the [Hardware Management Console](#) topic). Then continue with the next step.
  - ◆ No: Select DST using Function 21 for the failing partition (see [Control panel functions](#) in [Service functions](#)). Then continue with the next step.
2. Select Work with disk units and take the actions to protect the system.

If you do not know what actions to take, select Manual mode and perform an IPL to DST for the failing partition. See [Performing an IPL to DST](#).

When the Disk configuration error report appears, the recovery actions are listed in the Help text for the error message "Unprotected disk units in a mirrored ASP". This ends the procedure.

0005

A disk unit using parity protection is operating in exposed mode.

1. Select Manual mode and perform an IPL to DST for the failing partition. See [Performing an IPL to DST](#).
2. Choose from the following options:
  - ◆ If the same reference code appears, ask your next level of support for assistance.
  - ◆ If no reference code appears and the IPL completes successfully, the problem is corrected.
  - ◆ If a different reference code appears, use it to correct the problem. See the [Reference codes](#) topic. This ends the procedure.

0006

There are new devices attached to the system that do not have Licensed Internal Code installed. Ask your next level of support for assistance.

0007

Some of the configured disk units have device parity protection disabled when the system expected device parity protection to be enabled.

1. Is the system managed by an HMC?
  - ◆ Yes: Select DST by performing the HMC action for Function 21 for the failing partition (see [Control panel functions](#) in the [Hardware Management Console](#) topic). Then continue with the next step.
  - ◆ No: Select DST using Function 21 for the failing partition (see [Control panel functions](#) in [Service functions](#)). Then continue with the next step.
2. Correct the problem by doing the following:
  - a. Select Work with disk units > Work with disk unit recovery > Correct device parity protection.
  - b. Follow the online instructions. This ends the procedure.

0008

A disk unit has no more alternate sectors to assign.

1. Determine the failing unit by type, model, serial number or address given in words 4-7. See [System Reference Code \(SRC\) information](#).
2. See the service information for the specific storage device. Use the disk unit reference code listed below for service information entry.

432x 102E, 660x 102E, 671x 102E, 673x 102E (see [Reference codes](#)).

This ends the procedure.

0009

The procedure to restore a disk unit from the tape unit did not complete. Continue with the disk unit exchange recovery procedure. See [Disk unit recovery procedures](#).

000A

There is a problem with a disk unit subsystem. As a result, there are missing disk units in the system.

Perform the following:

1. Is the system managed by an HMC?
  - ◆ Yes: Select DST by performing the HMC action for Function 21 for the failing partition (see [Control panel functions](#) in the [Hardware Management Console](#) topic). Then continue with the next step.
  - ◆ No: Select DST using Function 21 for the failing partition (see [Control panel functions](#) in [Service functions](#)). Then continue with the next step.
2. On the Service Tools display, select Start a Service Tool > Product activity log > Analyze log.
3. On the Select Subsystem Data display, select the option to view All Logs.

**Note:** You can change the From: and To: Dates and Times from the 24-hour default if the time that the customer reported having the problem was more than 24 hours ago.

4. Use the defaults on the Select Analysis Report Options display by pressing Enter.
5. Search the entries on the Log Analysis Report display for system reference codes associated with the missing disk units.
6. Go to [Reference codes](#) to correct the problem. This ends the procedure.

000B

Some system IOPs require cache storage be reclaimed.

1. Is the system managed by an HMC?
  - ◆ Yes: Select DST by performing the HMC action for Function 21 for the failing partition (see [Control panel functions](#) in the [Hardware Management Console](#) topic). Then continue with the next step.
  - ◆ No: Select DST using Function 21 for the failing partition (see [Control panel functions](#) in [Service functions](#)). Then continue with the next step.
2. Reclaim the cache adapter card storage. See [Reclaiming IOP cache storage](#).

**Note:** The system operator may want to restore data from the most recent saved tape after you complete the repair.

This ends the procedure.

000C

One of the mirror protected disk units has no more alternate sectors to assign.

1. Determine the failing unit by type, model, serial number or address given in words 4-7. See [System Reference Code \(SRC\) information](#).
  2. See the service information for the specific storage device. Use the disk unit reference code listed below for service information entry.
    - ◆ 432x 102E, 660x 102E, 671x 102E, 673x 102E (see [Reference codes](#)).
- This ends the procedure.

000D

The system disk capacity has been exceeded.

000E

Start compression failure.

1. Select Manual mode and perform an IPL to DST for the failing partition. See [Performing an IPL to DST](#).
2. Correct the problem by doing the following:
  - a. Select Work with disk units > Work with disk unit recovery > Recover from start compression failure.
  - b. Follow the on-line instructions. This ends the procedure.

0010

The disk configuration has changed.

The operating system must be installed again, and all customer data must be restored.

1. Select Manual mode on the control panel.
2. Perform an IPL to reinstall the operating system.
3. The customer must restore all data from the latest system backup. This ends the procedure.

0011

The serial number of the control panel does not match the system serial number.

1. Select Manual mode on the control panel.
2. Perform an IPL. You will be prompted for the system serial number. This ends the procedure.

0012

The operation to write the vital product data (VPD) to the control panel failed.

Exchange the multiple function I/O processor card. See [Finding part locations](#) for the model you are working on for the location of the card and a link to the remove and replace procedure.

0015

The mirrored load-source disk unit is missing from the disk configuration. Go to step 1 for cause code 0002.

0016

A mirrored protected disk unit is missing. Wait six minutes. If the same reference code appears, go to step 1 for cause code 0002.

0017

One or more disk units have a lower level of mirrored protection than originally configured.

1. Select Manual mode and perform an IPL to DST for the failing partition. See [Performing an IPL to DST](#).
2. Review the detailed display, which shows the new and the previous levels of mirrored protection. This ends the procedure.

0018

Load-source configuration problem. The load-source disk unit is using mirrored protection and is configured at an incorrect address. Ensure that the load-source disk unit is in device location 1.

0019

One or more disk units were formatted incorrectly.

The system will continue to operate normally. However, it will not operate at optimum performance. To repair the problem, perform the following:

1. Record the unit number and serial number of the disk unit that is formatted incorrectly.
2. Sign on to DST. See [Accessing Dedicated Service Tools](#).
3. Select Work with disk units > Work with disk unit configuration > Remove unit from configuration.
4. Select the disk unit you recorded earlier in this procedure.
5. Confirm the option to remove data from the disk unit. This step may take a long time because the data must be moved to other disk units in the auxiliary storage pool (ASP).
6. When the remove function is complete, select Add unit to configuration.
7. Select the disk unit you recorded earlier in this procedure.
8. Confirm the add. The disk unit is formatted during functional operation. This ends the procedure.

001A

The load-source disk unit data is down-level.

The load-source disk unit is mirror protected. The system is using the load-source disk unit that does not have the current level of data.

1. Select Manual mode and perform an IPL to DST for the failing partition. See [Performing an IPL to DST](#). Does the Disk Configuration Error Report display appear?
  - ◆ No: The system is now using the correct load-source. This ends the procedure.
  - ◆ Yes: Continue with the next step.
2. Does a "Load source failure" message appear in the list?
  - ◆ Yes: Continue with the next step.
  - ◆ No: The system is now using the correct load-source. This ends the procedure.
3. Select option 5, press F11, and then press Enter to display details.

The load-source type, model, and serial number information that the system needs is displayed on the console.

Is the load-source disk unit (displayed on the console) attached to an MSIOP that cannot be used for a load-source?

- ◆ Yes: Contact your next level of support. This ends the procedure.
- ◆ No: The load-source disk unit is missing. Go to step 1 for cause code 0002.

001C

The disk units that are needed to update the system configuration are missing.

Perform an IPL by doing the following:

1. Select Manual mode on the control panel.
2. Perform an IPL. See [IPL information](#) to determine the cause of the problem. This ends the procedure.

001D

1. Is the Disk Configuration Attention Report, or the Disk Configuration Warning Report displayed?
  - ◆ Yes: Continue with the next step.
  - ◆ No: Ask your next level of support for assistance. This ends the procedure.
2. On the Bad Load Source Configuration message line, select 5, and press Enter to rebuild the load-source configuration information. If there are other types of warnings, select option 5 on the warnings, and correct the problem. This ends the procedure.

001E

The load-source data must be restored. See [Disk unit recovery procedures](#).

001F

Licensed Internal Code was installed on the wrong disk unit of the load-source mirrored pair.

The system performed an IPL on a load source that may not contain the same level of Licensed Internal Code that was installed on the other load source. The type, model, and address of the active device are displayed in words 4-7 of the SRC.

Choose from the following options:

- a. If the load-source disk unit in position 1 contains the correct level of Licensed Internal Code, perform the following:
  - i. Select Manual mode and perform an IPL to DST for the failing partition. See [Performing an IPL to DST](#). Is the Disk Configuration Attention Report or Disk Configuration Warning Report displayed?
    - ◆ Yes: Select option 5 on the Incorrect Licensed Internal Code Install message line. When the Display Incorrect Licensed Internal Code Install display appears on the console, press Enter.
    - ◆ No: The system is now using the correct load source. This ends the procedure.
- b. If the load-source disk unit in position 1 of the system unit does not contain the correct level of Licensed Internal Code, restore the Licensed Internal Code to the disk unit in position 1 of the system unit. See [Utilities to Install and Restore Licensed Internal Code](#). This ends the procedure.

0020

The system appears to be a one disk unit system. Select Manual mode and perform an IPL to DST for the failing partition. See [Performing an IPL to DST](#).

0021

The system password verification failed.

1. Select Manual mode and perform an IPL to DST for the failing partition. See [Performing an IPL to DST](#).
2. When prompted, enter the correct system password. If the correct system password is not available perform the following:
  - a. Select Bypass the system password.

- b. Have the customer contact the marketing representative immediately to order a new system password from your service provider. This ends the procedure.

0022

A different compression status was expected on a reporting disk unit. Accept the warning. The reported compression status will be used as the current compression status.

0023

There is a problem with a disk unit subsystem. As a result, there are missing disk units in the system. The system is capable of IPLing in this state.

1. Is the system managed by an HMC?
  - ◆ Yes: Select DST by performing the HMC action for Function 21 for the failing partition (see [Control panel functions](#) in the [Hardware Management Console](#) topic). Then continue with the next step.
  - ◆ No: Select DST using Function 21 for the failing partition (see [Control panel functions](#) in [Service functions](#)). Then continue with the next step.
2. On the Service Tools display, select Start a Service Tool > Product activity log > Analyze log.
3. On the Select Subsystem Data display, select the option to view All Logs.

**Note:** You can change the From: and To: Dates and Times from the 24-hour default if the time that the customer reported having the problem was more than 24 hours ago.

4. Use the defaults on the Select Analysis Report Options display by pressing Enter.
5. Search the entries on the Log Analysis Report display for system reference codes associated with the missing disk units.
6. Go to the [Reference codes](#) topic and use the SRC information to correct the problem. This ends the procedure.

0024

The system type or system unique ID needs to be entered.

1. Select Manual mode and perform an IPL to DST for the failing partition. See [Performing an IPL to DST](#).
2. When prompted, enter the correct system type or system unique ID. This ends the procedure.

0025

Hardware Resource Information Persistence disabled.

1. Select Manual mode and perform an IPL to DST for the failing partition. See [Performing an IPL to DST](#).



2. Contact your next level of support for instructions on how to enable the Hardware Resource Information Persistence function. This ends the procedure.

0026

A disk unit is incorrectly configured for an LPAR system.

1. Select Manual mode and perform an IPL to DST for the failing partition. See [Performing an IPL to DST](#).
2. On the Service Tools display, select Start a Service Tool > Product activity log > Analyze log.
3. On the Select Subsystem Data display, select the option to view All Logs.

**Note:** You can change the From: and To: Dates and Times from the 24-hour default if the time that the customer reported having the problem was more than 24 hours ago.

4. Use the defaults on the Select Analysis Report Options display by pressing Enter.
5. Search the entries on the Log Analysis Report display for system reference codes (B6xx 53xx) that are associated with the error.
6. Go to the [Reference codes](#) topic and use the SRC information to correct the problem. This ends the procedure.

0027

The user ASP has overflowed. Contact your next level of support.

0031

A problem was detected with the installation of Licensed Internal Code service displays. The cause may be defective media, the installation media being removed too early, a device problem or a Licensed Internal Code problem.

- Ask your next level of support for assistance. Characters 13-16 of the top 16 character line of function 12 (4 rightmost characters of word 3) contain information regarding the install error.
- If the customer does not require the service displays to be in the national language, you may be able to continue by performing another system IPL. This ends the procedure.

0033

System model not supported. This model of hardware does not support the System Licensed Internal Code version and release that is being used. Use a supported version and release of the System Licensed Internal Code.

0034

Insufficient main storage capacity.

There is not enough main storage capacity. For details about how much more capacity is required, see the "Insufficient Main Storage Capacity" screen, which is displayed when the system is IPLed in manual mode. Typically, this error occurs when you have moved memory between logical partitions, and one partition no longer has a sufficient amount of main storage.

0037

One or more functional connections to a disk unit in a multi-path environment have not been detected. The connections to the disk unit were established by running ESS Specialist. If you use the server in this state, you may cause a loss of data. You must ensure that all of the functional connections are still established between the disk and the Input/Output Adapters (IOAs) attached to this server and this logical partition. If there is an IOA which has a connection to the disk unit that has been moved to a different logical partition or different server, you should not continue with the IPL. Notify your next level of support.

0099

A Licensed Internal Code program error occurred. Ask your next level of support for assistance.

## LICIP12

Use this procedure to isolate an Independent Auxiliary Storage Pool (IASP) vary on failure.

Message CPDB8E0 occurred if the user attempted to vary on the IASP. Read the Danger notices in [Licensed internal code \(LIC\) isolation procedures](#) before continuing with this procedure.

**Parent topic:** [Licensed internal code \(LIC\) isolation procedures](#)

### How to find the cause code

1. If the system has logical partitions, perform this procedure from the logical partition that reported the problem. To determine if the system has logical partitions, go to [Determining if the system has logical partitions](#) before continuing with this procedure.
2. Were you given a cause code by another procedure?
  - ◆ No: Continue with the next step.
  - ◆ Yes: Use the cause code given by the other procedure. Then go to step 4.
3. Look at the characters in word 3. You can obtain these characters by doing the following:
  - a. On the command line, enter the Start System Service Tools (STRSST) command. If you cannot get to SST, use function 21 to get to DST. See [Selecting Function 21 while the system is operational](#). Do not IPL the system to get to DST.
  - b. On the Start Service Tools Sign On display, type in a User ID with service authority and password.
  - c. Select Start a Service Tool > Hardware Service Manager > Work with service action log.
  - d. On the Select Timeframe display, change the From: Date and Time to a date and time prior to when the user attempted to vary on the IASP.

- e. Search for a B6005094 system reference code that occurred at the time the user attempted to vary on the IASP. Display the failing item information for this entry.
  - f. Select the function key for Additional details.
  - g. The 4 leftmost characters of word 3 is the cause code to be used in this procedure.
4. Find the cause code below:

|      |      |      |      |
|------|------|------|------|
| 0002 | 000A | 002C | 0030 |
| 0004 | 000B | 002D | 0032 |
| 0007 | 000D | 002E | 0099 |
| 0009 | 000E | 002F |      |

0002

Disk units are missing from the IASP disk configuration.

1. Have you installed a new disk enclosure in a disk unit and not restored the data to the disk unit?
  - ◆ No: Continue with the next step.
  - ◆ Yes: Ignore SRC A600 5094.

Continue with the disk unit exchange recovery procedure. See [Disk unit recovery procedures](#). This ends the procedure.

2. Use words 1-9 from the information in the Service Action Log to determine the disk unit that is missing from the configuration:
  - ◆ Word 4 contains the IOP direct select address.
  - ◆ Word 5 contains the unit address.
  - ◆ Word 6 contains the disk unit type, level and model number.
  - ◆ Word 7 contains the disk unit serial number.
  - ◆ Word 8 contains the number of missing disk units.

Are the problem disk units 432x, 660x, or 671x Disk Units?

- ◆ Yes: Continue with the next step.
- ◆ No: Attempt to get all devices attached to the IOP to Ready status by performing the following:
  - a. The IOP address (IOP Direct Select Address) to use is Word 4.
  - b. Verify the following, and correct if necessary:
    - Ensure all cable connections are made correctly and are tight.
    - Ensure the configuration within the device is correct.
    - Ensure all storage devices are powered on and ready.
  - c. Continue with the next step.

3. Perform the following:

Select System Service Tools (SST) > Work with disk units > Display disk configuration > Display disk configuration status.

Are any disk units missing-indicated with an asterisk (\*)- from the IASP configuration?

- ◆ Yes: Continue with the next step.
  - ◆ No: This ends the procedure.
4. Use the Service Action Log to determine if there are any entries other than B6xx 5094 for the missing disk units or the IOA or IOP that is controlling them. See [Using the Service Action Log](#).

Are there any entries in the Service Action Log other than B6xx 5094 for the missing disk units or the IOA or IOP that is controlling them?

- ◆ No: Continue with the next step.
  - ◆ Yes: Use the information in the Service Action Log to solve the problem. See [Using the Service Action Log](#). This ends the procedure.
5. Did you enter this procedure because there was a B6xx 5094 cause code of 0030?

- ◆ No: Continue with the next step.
  - ◆ Yes: Work with the customer to recover the unknown configuration source disk unit.
6. Use Hardware Service Manager to display logical resources connected to the IOP. See [Hardware Service Manager](#).
7. Is every device attached to the IOP failing?
- ◆ Yes: Continue with the next step.
  - ◆ No: Are all of the disk units that are attached to one IOA missing?
    - ◇ No: Continue with the next step.
    - ◇ Yes: Exchange the IOA. Use the IOP direct select address and the first character of the unit address from step 2 to find the location. See [Finding part locations](#). This ends the procedure.
8. Is there more than one storage IOA attached to the IOP?
- ◆ Yes: Exchange the IOP. Use the IOP direct select address from step 2 to find the location. See [Finding part locations](#). This ends the procedure.
  - ◆ No: Go to step 10.
9. Go to the service information for the specific disk unit that is listed below and perform the action indicated. Then return here and answer the following question.
- ◆ 2105 Disk Units: Use SRC 3002 in [\(2105, 2107\) Disk unit reference codes](#) and exchange the FRUs shown one at a time.
  - ◆ 432x, 660x, 671x Disk Units: Use SRC 3002 in the [Reference codes list](#) and exchange the FRUs shown one at a time.
- Did the disk unit service information correct the problem?
- ◆ No: Continue with the next step.
  - ◆ Yes: This ends the procedure.
10. Perform the following:
- a. Exchange the IOA. Use the IOP direct select address and the first character of the unit address from step 2 to find the location. See [Finding part locations](#).
  - b. If exchanging the IOA does not correct the problem, exchange the IOP. Use the IOP direct select address from step 2 to find the location. See [Finding part locations](#).
  - c. If exchanging the IOP does not correct the problem, exchange the failing items in the following FRU list starting with the first item in the list.
    - i. FI01140
    - ii. [BACKPLN](#)
    - iii. FI00580
    - iv. AJDG301

This ends the procedure.

0004

Some disk units are unprotected but configured into a mirrored IASP. These units were originally DPY protected but protection was disabled.

Direct the customer to take the actions necessary to start protection on these disk units. This ends the procedure.

0007

Some of the configured disk units have device parity protection disabled when the system expected device parity protection to be enabled.

1. Select Manual mode and perform an IPL to DST. See [Performing an IPL to DST](#).
2. Correct the problem by doing the following:
  - a. Select Work with disk units > Work with disk unit recovery > Correct device parity protection mismatch.
  - b. Follow the on-line instructions. This ends the procedure.

0008

A disk unit has no more alternate sectors to assign.

1. Determine the failing unit by type, model, serial number or address given in words 4-7. See [System Reference Code \(SRC\) information](#).
2. See the service information for the specific storage device. Use the disk unit reference code listed below for service information entry.

432x 102E, 660x 102E, 671x 102E (see the [Reference codes](#) topic). This ends the procedure.

0009

The procedure to restore a disk unit from the tape unit did not complete.

Continue with the disk unit exchange recovery procedure. See [Disk unit recovery procedures](#). This ends the procedure.

000A

There is a problem with a disk unit subsystem. As a result, there are missing disk units in the system.

Use the Service Action Log to find system reference codes associated with the missing disk units by changing the From: Date and Time on the Select Timeframe display to a date and time prior to when the user attempted to vary on the IASP. For information on how to use the Service Action Log, see [Using the Service Action Log](#). This ends the procedure.

000B

Some system IOPs require cache storage be reclaimed.

1. Start SST.
2. Reclaim the cache adapter card storage by performing the following:
  - a. Select Work with disk units > Work with disk unit recovery > Reclaim IOP Cache Storage.
  - b. Follow the on-line instructions to reclaim cache storage.
  - c. After you complete the repair, the system operator may want to restore data from the most recently saved tape. This ends the procedure.

000D

The system disk capacity has been exceeded.

000E

Start compression failure.

1. Select Manual mode and perform an IPL to DST. See [Performing an IPL to DST](#).
2. Correct the problem by doing the following:
  - a. Select Work with disk units > Work with disk unit recovery > Recover from start compression failure.
  - b. Follow the on-line instructions. This ends the procedure.

002C

A Licensed Internal Code program error occurred.

Ask your next level of support for assistance. This ends the procedure.

002D

The IASP configuration source disk unit data is down-level.

The system is using the IASP configuration source disk unit that does not have the current level of data.

002E

The Independent ASP is assigned to another system or a Licensed Internal Code program error occurred.

Work with the customer to check other systems to determine if the Independent ASP has been assigned to it. If the Independent ASP has not been assigned to another system, ask your next level of support for assistance. This ends the procedure.

002F

The system version and release are at a different level than the IASP version and release.

The system version and release must be upgraded to be the same as the system version and release in which the IASP was created. This ends the procedure.

0030

The mirrored IASP configuration source disk unit has a disk configuration status of *unknown* and is missing from the disk configuration.

Go to step 1 for cause code 0002.

0032

A Licensed Internal Code program error occurred.

Ask your next level of support for assistance. This ends the procedure.

0099

A Licensed Internal Code program error occurred.

Ask your next level of support for assistance. This ends the procedure.

## LICIP13

A disk unit seems to have stopped communicating with the system.

The system has stopped normal operation until the cause of the disk unit failure is found and corrected. Ensure you have read the Danger notices in [Licensed internal code \(LIC\) isolation procedures](#) before continuing with this procedure.

If the disk unit that stopped communicating with the system has mirrored protection active, normal operation of the system stops for one to two minutes. Then the system suspends mirrored protection for that disk unit and continues normal operation. See [Disk unit recovery procedures](#) for more information on systems with mirrored protection.

**Note:** Do not power off the system or partition using the white button, function 08, ASMI, or HMC immediate power-off when performing this procedure. If this procedure or other isolation procedures referenced by this procedure direct you to IPL or power off the system,

- perform a partition main storage dump (see [Performing a platform or main storage dump](#)), or
- if additional dump information is not needed, perform a function 03 IPL or restart the system or partition using the HMC.

1. If the system has logical partitions, perform this procedure from the logical partition that reported the problem. To determine if the system has logical partitions, go to [Determining if the system has logical partitions](#) before continuing with this procedure.
2. Was a problem summary form completed for this problem?
  - ◆ No: Continue with the next step.
  - ◆ Yes: Use the problem summary form information and go to step 4.
3. Fill out a [problem reporting form](#) completely with the instructions provided.
4. Recovery from a device command time-out may have caused the communications loss condition (indicated by an SRC on the control panel or in the HMC). This communications loss condition has the following symptoms:
  - ◆ The A6xx SRC does not increment within two minutes.

- ◆ The system continues to run normally after it recovers from the communications loss condition and the reference code is cleared from the control panel.

Does the communication loss condition have the above symptoms?

- ◆ Yes: Continue with the next step.
- ◆ No: Go to step 6.

5. Verify that all Licensed Internal Code PTFs have been applied to the system. Apply any Licensed Internal Code PTFs that have not been applied to the system. Does the intermittent condition continue?

- ◆ Yes: Print all product activity logs. Print the LIC logs with a major code of 1000. Provide this information to your next level of support. This ends the procedure.
- ◆ No: This ends the procedure.

6. A manual reset of the IOP may clear the attention reference code. Perform the following:

**If you are working from the control panel:**

- a. Select *Manual* mode on the control panel.
- b. Select Function 25 and press Enter.
- c. Select Function 26 and press Enter.
- d. Select Function 67 and press Enter to reset the IOP.
- e. Wait 10 minutes.
- f. Select Function 25 and press Enter to disable the service functions on the control panel.

**If you are working from the HMC:**

- a. In the Navigation Area, open the Service Applications folder.
- b. Select Service Focal Point.
- c. In the contents area, select Service Utilities.
- d. In the Service Utilities window, select the system you are working on.
- e. Select Selected > Operator Panel Service Functions.
- f. Select the logical partition, and then select Partition Functions.
- g. Select Disk Unit IOP Reset/Reload (67).
- h. Wait 10 minutes.

Did the reset successfully clear the control panel SRC or HMC panel value and can commands be entered on the partition console?

- ◆ No: Continue with the next step.
- ◆ Yes: Look for a Service Action Log (SAL) entry since the last IPL, and use it to fix the problem (see [Using the Service Action Log](#)). If a B6xx 5090 SRC occurred since the last IPL, look for other SRC entries and take action on them first. This ends the procedure.

7. Is the SRC the same reference code that sent you here?

- ◆ Yes: The same reference code occurred. Continue with the next step.
- ◆ No: Collect all words of the reference code and go to [Reference codes](#) to resolve the new problem. This ends the procedure.

8. Powering off and powering on the affected IOP domain may clear the attention reference code. Perform the following:

**If you are working from the control panel:**

- a. Select *Manual* mode on the control panel.
- b. Select Function 25 and press Enter.
- c. Select Function 26 and press Enter.
- d. Select Function 68 and press Enter to power off the domain.
- e. After the domain has been powered off or 10 minutes have passed, select Function 69 and press Enter to power on the domain.
- f. Wait 10 minutes.
- g. Select Function 25 and press Enter to disable the service functions on the control panel.

**If you are working from the HMC:**

- a. In the Navigation Area, open the Service Applications folder.
- b. Select Service Focal Point.
- c. In the contents area, select Service Utilities.
- d. In the Service Utilities window, select the system you are working on.
- e. Select Selected > Operator Panel Service Functions.
- f. Select the logical partition, and then select Partition Functions.
- g. Select Power off domain (68).
- h. After the domain has been powered off or 10 minutes have passed, select Power on domain (69).



i. Wait 10 minutes.

Did this successfully clear the control panel SRC or HMC panel value, and can commands be entered on the partition console?

- ◆ No: Continue with the next step.
- ◆ Yes: Look for a SAL entry since the last IPL, and use it to fix the problem (see [Using the Service Action Log](#)). If a B6xx 5090 SRC occurred since the last IPL, look for other SRC entries and take action on them first. This ends the procedure.

9. Is the SRC the same reference code that sent you here?

- ◆ Yes: The same reference code occurred. Continue with the next step.
- ◆ No: Collect all words of the reference code and go to [Reference codes](#) to resolve the new problem. This ends the procedure.

10. Perform a main storage dump, then perform an IPL by performing the following:

**If you are working from the control panel:**

- a. Select *Manual* mode on the control panel.
- b. Select Function 22 and press Enter to dump the main storage to the load-source disk unit.
- c. Wait for SRC A100 300x to occur, indicating that the dump is complete.
- d. Then perform an IPL to DST (see [Performing an IPL to DST](#)).

**If you are working from the HMC:**

- a. In the Navigation Area, open Server and Partition.
- b. Select Server Management.
- c. In the contents area, open the server on which the logical partition is located.
- d. Select Partitions.
- e. Right-click the logical partition profile and select Restart Partition.
- f. In the Restart Partition window, select the Dump restart option.

Does a different SRC occur, or does a display appear on the console showing reference codes?

- ◇ No: Continue with the next step.
- ◇ Yes: Go to [Reference codes](#) to service the new problem. This ends the procedure.

11. Does the same reference code occur?

- ◆ Yes: Continue with the next step.
- ◆ No: The problem is intermittent. Perform the following:
  - a. Print the system product activity log for the magnetic storage subsystem and print the LIC logs with a major code of 1000.
  - b. Copy the main storage dump to removable media (see [Copying a current main storage dump](#)).
  - c. Contact your next level of support and provide them with this information. This ends the procedure.

12. Are characters 7-8 of the top 16 character line of function 12 (2 rightmost characters of word 2) equal to 13 or 17?

- ◆ Yes: Continue with the next step.
- ◆ No: Go to step [15](#).

13. Use the word 1 through 9 information recorded on the Problem summary form to determine the disk unit that stopped communicating with the system:

- ◆ Characters 9-16 of the top 16 character line of function 12 (word 3) contain the IOP direct select address.
- ◆ Characters 1-8 of the bottom 16 character line of function 12 (word 4) contains the unit address.
- ◆ Characters 1-8 of the top 16 character line of function 13 (word 6) may contain the disk unit type, level and model number.
- ◆ Characters 13-16 of the top 16 character line of function 13 (4 rightmost characters of word 7) may contain the disk unit reference code.
- ◆ Characters 1-8 of the bottom 16 character line of function 13 (word 8) may contain the disk unit serial number.

**Note:** For 2105 and 2107 disk units, characters 4-8 of the bottom 16 character line of function 13 (5 rightmost characters of word 8) contain the disk unit serial number.

14. Is the disk unit reference code 0000?

- ◆ No: Using the information from step 13, find the table for the indicated disk unit type in the [Reference codes](#) topic. Perform problem analysis for the disk unit reference code. This ends the procedure.
  - ◆ Yes: Perform the following steps:
    - a. Determine the IOP type by using characters 9-12 of the bottom 16 character line of function 13 (4 leftmost characters of word 9).
    - b. Find the unit reference code table for the IOP type in the [Reference codes](#) topic. Determine the unit reference code by using characters 13-16 of the bottom 16 character line of function 13 (4 rightmost characters of word 9).
    - c. Perform problem analysis for the unit reference code. This ends the procedure.
15. Are characters 7-8 of the top 16 character line of function 12 (the two rightmost characters of word 2) equal to 27?
- ◆ Yes: Continue with the next step.
  - ◆ No: Go to step 19.
16. Use the word 1 through 9 information recorded on the Problem summary form to determine the disk unit that stopped communicating with the system:
- ◆ Characters 9-16 of the top 16 character line of function 12 (word 3) contain the IOP direct select address.
  - ◆ Characters 1-8 of the bottom 16 character line of function 12 (word 4) contains the disk unit address
  - ◆ Characters 9-16 of the bottom 16 character line of function 12 (word 5) contains the disk unit type, level and model number.
  - ◆ Characters 1-8 of the bottom 16 character line of function 13 (word 8) contains the disk unit serial number.

**Note:** For 2105 and 2107 Disk Units, characters 4-8 of the bottom 16 character line of function 13 (5 rightmost characters of word 8) contain the disk unit serial number.

- ◆ Characters 13-16 of the bottom 16 character line of function 13 (4 rightmost characters of word 9) contain the disk unit reference code.
17. Is the disk unit reference code 0000?
- ◆ No: Continue with the next step.
  - ◆ Yes: Find the table for the indicated disk unit type in the [Reference codes](#) topic. Then find unit reference code (URC) 3002 in the table, and exchange the FRUs for that URC, one at a time.

**Note:** Do not perform any other isolation procedures that are associated with URC 3002.

This ends the procedure.

18. Are characters 9-16 of the bottom 16 character line of function 13 (word 9) B6xx 51xx?
- ◆ Yes: Use the B6xx table in the [Reference codes](#) topic. Perform problem analysis for the 51xx unit reference code. This ends the procedure.
  - ◆ No: Using the information from step 16, find the table for the indicated disk unit type in the [Reference codes](#) topic. Perform problem analysis for the disk unit reference code. This ends the procedure.
19. Are the 2 rightmost characters of word 2 on the Problem summary form equal to 62?
- ◆ No: Use the information in characters 9-16 of the bottom 16 character line of function 13 (word 9) and go to the [Reference codes](#) topic. Use this information instead of the information in word 1 for the reference code. This ends the procedure.
  - ◆ Yes: Continue with the next step.
20. Are characters 9-16 of the top 16 character line of function 12 (word 3) equal to 00010004?
- ◆ Yes: Continue with the next step.
  - ◆ No: Go to step 23.
21. Are characters 13-16 of the bottom 16 character line of function 12 (4 rightmost characters of word 5) equal to 0000?
- ◆ No: Continue with the next step.
  - ◆ Yes: Go to step 24.
22. Note the following:
- ◆ Characters 13-16 of the bottom 16 character line of function 12 (4 rightmost characters of word 5) contain the disk unit reference code.

- ◆ Characters 1-8 of the top 16 character line of function 13 (word 6) contains the disk unit address.
- ◆ Characters 9-16 of the top 16 character line of function 13 (word 7) contain the IOP direct select address.
- ◆ Characters 1-8 of the bottom 16 character line of function 13 (word 8) contains the disk unit type, level and model number.

Find the table for the disk unit type (characters 1-4 of the bottom 16 character line of function 13 - 4 leftmost characters of word 8) in the [Reference codes](#) topic, and use characters 13-16 of the bottom 16 character line of function 12 (4 rightmost characters of word 5) as the unit reference code. This ends the procedure.

23. Are characters 9-16 of the top 16 character line of function 12 (word 3) equal to 0002000D?
- ◆ **Yes:** Continue with the next step.
  - ◆ **No:** Use the information in characters 9-16 of the bottom 16 character line of function 13 (word 9), instead of the information in word 1 for the reference code, and go to the [Reference codes](#) topic.
    - ◇ Characters 1-8 of the top 16 character line of function 13 (word 6) may contain the disk unit address.
    - ◇ Characters 9-16 of the top 16 character line of function 13 (word 7) may contain the IOP direct select address.
    - ◇ Characters 1-8 of the bottom 16 character line of function 13 (word 8) may contain the disk unit type, level and model number. This ends the procedure.
24. Note the following:
- ◆ Characters 1-8 of the top 16 character line of function 13 (word 6) contains the disk unit address.
  - ◆ Characters 9-16 of the top 16 character line of function 13 (word 7) contain the IOP direct select address.
  - ◆ Characters 1-8 of the bottom 16 character line of function 13 (word 8) contains the disk unit type, level and model number.

Find the table for the disk unit type (characters 1-4 of the bottom 16 character line of function 13 (4 leftmost characters of word 8) in the [Reference codes](#) topic and use 3002 as the unit reference code. Exchange the FRUs for URC 3002 one at a time. This ends the procedure.

**Parent topic:** [Licensed internal code \(LIC\) isolation procedures](#)

---

## LICIP14

Licensed Internal Code detected a card slot test failure.

1. Has the I/O adapter moved to a new card location?
  - ◆ **Yes:** Continue with the next step.
  - ◆ **No:** Go to step 4.
2. Perform one of the following, and then continue with the next step:
  - ◆ Use the concurrent maintenance option in Hardware Service Manager in SST/DST to power off, remove, reinsert, and power on the I/O adapter.

OR

  - ◆ Power off the system, remove and reinsert the I/O adapter. Then IPL the system.
3. Does the reference code occur again for this same I/O adapter?
  - ◆ **Yes:** Continue with the next step.
  - ◆ **No:** No further service action is needed.

### **This ends the procedure.**

4. Move the I/O adapter to a different card location, that has no I/O processors in the PCI bridge set, by performing one of the following, and then continue with the next step:
  - ◆ Use the concurrent maintenance option in Hardware Service Manager in SST/DST to power off, remove the I/O adapter, install the I/O adapter in a different card location, and power on the I/O adapter. OR
  - ◆ Power off the system, remove the I/O adapter, install the I/O adapter in a different card location, and then IPL the system.
5. Does the same reference code occur again for this I/O adapter?
  - ◆ **Yes:** Replace the I/O adapter.

### **This ends the procedure.**

- ◆ **No:** Replace the backplane.

**This ends the procedure.**

Parent topic: [Licensed internal code \(LIC\) isolation procedures](#)

---

**LICIP15**

Use this procedure to help you recover from an initial program load (IPL) failure.

1. Is the system HMC-managed?
  - ◆ **Yes:** Continue with the next step.
  - ◆ **No:** Go to step [3](#).
2. Check the LPAR configuration to ensure that the load source and alternate load source devices are valid. Is the LPAR configuration correct?
  - ◆ **Yes:** Continue with the next step.
  - ◆ **No:** Correct the LPAR configuration problem. **This ends the procedure.**
3. Did the failure occur when you were performing a type-D IPL?
  - ◆ **No:** Go to step [9](#).
  - ◆ **Yes:** Perform the following:
    - a. Ensure that the device is ready and has valid install media.
    - b. Ensure that the device has the correct SCSI address and that any cables are properly connected and terminated.

If a correction is made during the above checks, retry the IPL. If none of the above items resolve the problem, continue with the next step.
4. Are the load source and alternate load source devices controlled by the same I/O adapter, and does the load source disk unit have SLIC loaded on it?
  - ◆ **Yes:** Continue with the next step.
  - ◆ **No:** Go to step [6](#).
5. Perform a type-B IPL in manual mode. Does the same SRC occur?
  - ◆ **No:** Continue with the next step.
  - ◆ **Yes:** Replace the following items, one at a time, and retry the IPL until the problem is resolved (see [Finding part locations](#)):
    - a. The I/O adapter controlling load source and alternate load source devices.

**Note:** The I/O adapter may be embedded on the system unit backplane.

- b. The I/O processor controlling the load source I/O adapter.
  - c. The common cable, if present, attached between both the load source and alternate load source and the controlling I/O adapter.
  - d. If none of the items above resolve the problem, contact your next level of support.
- This ends the procedure.**
6. Replace the following items, one at a time, and retry the type-D IPL until the problem is resolved (see [Finding part locations](#)):
    - a. Media in the alternate load source device
    - b. Device cables (if present)
    - c. Media device
    - d. Media backplane
    - e. I/O adapter controlling the alternate load source device

**Note:** The I/O adapter may be embedded on the system unit backplane

- f. I/O processor controlling the alternate load source I/O adapter
  - g. If the problem persists after replacing each of these parts, contact your next level of support.
- This ends the procedure.**
7. You performed a type A or type B IPL. Is the load source I/O adapter a Fibre Channel adapter?
    - ◆ **Yes:** Continue with the next step.
    - ◆ **No:** Continue with step [9](#).
  8. Perform a type-D IPL in manual mode to DST. Look for other SRCs and use them to resolve the problem. If there are no SRCs, or if the SRCs do not resolve the problem, perform the actions for the 2847 3100 SRC (see [List of system reference codes](#)). **This ends the procedure.**

9. Is the device in a valid location (see [Finding part locations](#))?
  - ◆ **Yes:** Continue with the next step.
  - ◆ **No:** Correct the device location problem and retry the IPL. If the problem persists, continue with the next step.
10. Perform a type-D IPL in manual mode to DST. Is the type-D IPL successful?
  - ◆ **No:** Continue with the next step.
  - ◆ **Yes:** Look for other SRCs and use them to resolve the problem. If there are no SRCs, or the SRCs do not resolve the problem, replace the following items, one at a time, until the problem is resolved (see [Finding part locations](#)):
    - a. Load source disk drive
    - b. Cables (if present)
    - c. Disk drive backplane
    - d. I/O adapter controlling the load source device

**Note:** The I/O adapter may be embedded on the system unit backplane

- e. I/O processor controlling the load source I/O adapter
  - f. Backplane that the I/O adapter and I/O processor are plugged into
  - g. If the problem persists after replacing each of these parts, contact your next level of support. **This ends the procedure.**
11. The type-D IPL in manual mode to DST was not successful. Is the I/O adapter embedded on the system unit backplane?
  - ◆ **No:** Continue with the next step.
  - ◆ **Yes:** Go to step [18](#).
12. Are the load source and alternate load source controlled by the same I/O adapter?
  - ◆ **No:** Go to step [17](#).
  - ◆ **Yes:** Continue with the next step.
13. Replace the I/O adapter and perform a type-A or type-B IPL. Does the IPL complete successfully?
  - ◆ **Yes: This ends the procedure.**
  - ◆ **No:** Continue with the next step.
14. Perform a type-D IPL in manual mode to DST. Is the type-D IPL successful?
  - ◆ **No:** Continue with the next step.
  - ◆ **Yes:** Look for other SRCs and use them to resolve the problem. If there are no SRCs, or the SRCs do not resolve the problem, replace the following items, one at a time, until the problem is resolved (see [Finding part locations](#)):
    - a. Load source disk drive
    - b. Cables (if present)
    - c. Disk drive backplane
    - d. I/O adapter controlling the load source device

**Note:** The I/O adapter may be embedded on the system unit backplane

- e. I/O processor controlling the load source I/O adapter
  - f. Backplane that the I/O adapter and I/O processor are plugged into
  - g. If the problem persists after replacing each of these parts, contact your next level of support. **This ends the procedure.**
15. Are the load source and alternate load source controlled by different I/O adapters, but the same I/O processor?
  - ◆ **No:** Go to step [17](#).
  - ◆ **Yes:** Continue with the next step.
16. Replace the I/O processor and retry the IPL. Does the IPL complete successfully?
  - ◆ **Yes: This ends the procedure.**
  - ◆ **No:** Continue with the next step.
17. Replace the backplane that the I/O adapter and the I/O processor are plugged into and retry the IPL. If the IPL still fails, contact your next level of support. **This ends the procedure.**
18. Replace the I/O processor and retry the IPL. Does the IPL complete successfully?
  - ◆ **Yes: This ends the procedure.**
  - ◆ **No:** Replace the system unit backplane and retry the IPL. If the IPL still fails, contact your next level of support. **This ends the procedure.**

**Parent topic:** [Licensed internal code \(LIC\) isolation procedures](#)

## Logical partition (LPAR) isolation procedure

These procedures help you to identify logical partition (LPAR) configuration conditions and the associated corrective actions.

### **DANGER**When working on or around the system, observe the following precautions:

Electrical voltage and current from power, telephone, and communication cables are hazardous. To avoid a shock hazard:

- Connect power to this unit only with the provided power cord. Do not use the provided power cord for any other product.
- Do not open or service any power supply assembly.
- Do not connect or disconnect any cables or perform installation, maintenance, or reconfiguration of this product during an electrical storm.
- The product might be equipped with multiple power cords. To remove all hazardous voltages, disconnect all power cords.
- Connect all power cords to a properly wired and grounded electrical outlet. Ensure that the outlet supplies proper voltage and phase rotation according to the system rating plate.
- Connect any equipment that will be attached to this product to properly wired outlets.
- When possible, use one hand only to connect or disconnect signal cables.
- Never turn on any equipment when there is evidence of fire, water, or structural damage.
- Disconnect the attached power cords, telecommunications systems, networks, and modems before you open the device covers, unless instructed otherwise in the installation and configuration procedures.
- Connect and disconnect cables as described in the following procedures when installing, moving, or opening covers on this product or attached devices.
  - To Disconnect:
    1. Turn off everything (unless instructed otherwise).
    2. Remove the power cords from the outlets.
    3. Remove the signal cables from the connectors.
    4. Remove all cables from the devices

To Connect:

1. Turn off everything (unless instructed otherwise).
2. Attach all cables to the devices.
3. Attach the signal cables to the connectors.
4. Attach the power cords to the outlets.
5. Turn on the devices.

(D005)

- **LPRIP01**  
Use this procedure to isolate the problem when LPAR configuration data does not match the current system configuration.

Parent topic: [Isolation procedures](#)

## LPRIP01

Use this procedure to isolate the problem when LPAR configuration data does not match the current system configuration.

1. Is there **only one** B6005311 error logged, and is it against the load source device for the partition, in either the Primary or a secondary partition?
  - ◆ **Yes:** Is the reporting partition the Primary partition?
    - ◇ **Yes:** Continue with the next step.
    - ◇ **No:** Go to step 3.
  - ◆ **No:** Go to step 4.

2. Was the load source disk unit migrated from another partition within the same system?
  - ◆ **Yes:** Is this load source device intended to be the load source for the Primary partition?
    - ◇ **Yes:** To accept the load source disk unit: Go to SST/DST in the current partition and select Work with system partitions > Recover configuration data > Accept load source disk unit. **This ends the procedure.**
    - ◇ **No:** Power off the system. Return the original load source disk to the Primary partition and perform a system IPL. **This ends the procedure.**
  - ◆ **No:** The load source disk unit has not changed. Contact your next level of support. **This ends the procedure.**
3. The reporting partition is a secondary partition.

Since the last IPL of the reporting partition, have one of the following occurred?

- ◆ Has the Primary partition time/date been moved backward to a time/date earlier than the previous setting?
  - ◆ Has the system serial number been changed?
  - ◆ Was the load source disk unit in this secondary partition, replaced intentionally with a load source from another system or another partition from the same system?
  - ◆ **Yes:** To accept the load source disk unit: Go to SST/DST in the current partition and select Work with system partitions > Recover configuration data > Accept load source disk unit **This ends the procedure.**
  - ◆ **No:** Contact your next level of support. **This ends the procedure.**
4. Are there **multiple** B600 5311 SRCs logged in the same partition?
    - ◆ **Yes:** Continue with the next step.
    - ◆ **No:** None of the conditions in this procedure have been met, call your next level of support. **This ends the procedure.**
  5. Is the resource for **one** of the B600 5311 SRCs the load source device and are **all** of the other B600 5311 entries for resources which are non-configured disk units?
    - ◆ **Yes:** Is the partition that is reporting the error the **Primary** partition?
      - ◇ **Yes:** Continue with the next step.
      - ◇ **No:** Go to step 7.
    - ◆ **No:** Go to step 8.
  6. Was the load source disk unit migrated from another partition within the same system?
    - ◆ **Yes:** Is this load source device intended to be the load source for the Primary partition?
      - ◇ **Yes:** To accept the load source disk unit: Go to SST/DST in the current partition and select Work with system partitions > Recover configuration data > Accept load source disk unit **This ends the procedure.**
      - ◇ **No:** Power off the system. Return the original load source disk to the Primary partition and perform a system IPL. **This ends the procedure.**
    - ◆ **No:** The load source disk unit has not changed. Contact your next level of support. **This ends the procedure.**
  7. The reporting partition is a secondary partition.

Since the last IPL of the reporting partition, have one of the following occurred:

- ◆ Has the Primary partition time/date been moved backward to a time/date earlier than the previous setting?
  - ◆ Has the system serial number been changed?
  - ◆ Was the load source disk unit in this secondary partition, replaced intentionally with a load source from another system or another partition from the same system?
  - ◆ **Yes:** To accept the load source disk unit: Go to SST/DST in the current partition and select Work with system partitions > Recover configuration data > Accept load source disk unit **This ends the procedure.**
  - ◆ **No:** Contact your next level of support. **This ends the procedure.**
8. One or more B600 5311 SRCs have been logged in the same partition.

Do all of the B600 5311 errors have a resource which is a non-configured disk unit in the partition?

- ◆ **Yes:** Continue with the next step.
  - ◆ **No:** None of the conditions in this procedure have been met, call your next level of support. **This ends the procedure.**
9. Were any disk unit resources associated with the B600 5311 SRCs added to the partition, since the last IPL of this partition?
    - ◆ **No:** Continue with the next step.
    - ◆ **Yes:** Perform the following to clear non-configured disk unit configuration data:
      - a. Go to SST/DST in the partition and select Work with system partitions > Recover configuration data > Clear non-configured disk unit configuration data.

- b. Select each unit in the list which is new to the system and press Enter.
  - c. Continue the system IPL. **This ends the procedure.**
10. None of the resources that are associated with the B600 5311 SRCs are disk units that were added to the partition since the last IPL of the partition.

Has a scratch install recently been performed on the partition that is reporting the error(s)?

- ◆ **No:** Continue with the next step.
  - ◆ **Yes:** Go to step 13.
11. If a scratch install was not performed, was the clear configuration data option recently used to discontinue LPAR use?
    - ◆ **Yes:** Continue with the next step.
    - ◆ **No:** The Clear configuration data option was not used. Contact your next level of support. **This ends the procedure.**
  12. Perform the following to clear non-configured disk unit configuration data:
    - a. Go to SST/DST in the partition and select Work with system partitions > Recover configuration data > Clear non-configured disk unit configuration data.
    - b. Select each unit in the list which is new to the system and press Enter.
    - c. Continue the system IPL. **This ends the procedure.**
  13. Was the load source device previously mirrored before the scratch install?
    - ◆ **Yes:** Continue with the next step.
    - ◆ **No:** Go to step 15.
  14. Perform the following to clear the old configuration data from the disk unit that was mirroring the old load source disk
    - a. Go to SST/DST in the partition and select Work with system partitions > Recover configuration data > Clear non-configured disk unit configuration data.
    - b. Select the former load source mirror in the list and press Enter.
  15. Is the Primary partition reporting the B600 5311 error(s)?
    - ◆ **No: This ends the procedure.**
    - ◆ **Yes:** Does the customer want multiple partitions on the system?
      - ◇ **No: This ends the procedure.**
      - ◇ **Yes:** Use the Recover primary partition configuration data option to retrieve the LPAR configuration data from other devices in the system.
        - a. Go to SST/DST in the primary partition and select Work with system partitions > Recover configuration data > Recover primary partition configuration data. The system will perform an automatic IPL.
        - b. Verify the information that appears.
          - The device should be a former load source device from a secondary partition.
          - The time and date should reflect a time when that partition was active. It should be more recent than the last change to the logical partition configuration. **This ends the procedure.**

Parent topic: [Logical partition \(LPAR\) isolation procedure](#)

---

## Operations Console isolation procedures

These procedures help you to isolate a failure with the Operations Console.

### **DANGER**When working on or around the system, observe the following precautions:

Electrical voltage and current from power, telephone, and communication cables are hazardous. To avoid a shock hazard:

- Connect power to this unit only with the provided power cord. Do not use the provided power cord for any other product.
- Do not open or service any power supply assembly.
- Do not connect or disconnect any cables or perform installation, maintenance, or reconfiguration of this product during an electrical storm.
- The product might be equipped with multiple power cords. To remove all hazardous voltages, disconnect all power cords.
- Connect all power cords to a properly wired and grounded electrical outlet. Ensure that the outlet supplies proper voltage and phase rotation according to the system rating plate.



- Connect any equipment that will be attached to this product to properly wired outlets.
- When possible, use one hand only to connect or disconnect signal cables.
- Never turn on any equipment when there is evidence of fire, water, or structural damage.
- Disconnect the attached power cords, telecommunications systems, networks, and modems before you open the device covers, unless instructed otherwise in the installation and configuration procedures.
- Connect and disconnect cables as described in the following procedures when installing, moving, or opening covers on this product or attached devices.

To Disconnect:

1. Turn off everything (unless instructed otherwise).
2. Remove the power cords from the outlets.
3. Remove the signal cables from the connectors.
4. Remove all cables from the devices

To Connect:

1. Turn off everything (unless instructed otherwise).
2. Attach all cables to the devices.
3. Attach the signal cables to the connectors.
4. Attach the power cords to the outlets.
5. Turn on the devices.

(D005)

### For direct cable only.

The following symptoms can be caused by Operations Console failing to connect:

- SRC A600 5008
- The status in the Operations Console window remains "Connecting console".

The following symptoms can be caused by a defective remote control panel cable:

- Remote control panel (hung) System control panel functions.
- SRC 0000 DDDD with attention light on the system panel.
- Remote control panel accepts mode selections, however the system does not respond.
- The remote control panel does not function.
- The status in the Operations Console window remains "Connecting console".

The following safety notices apply throughout this section.

Read all safety procedures before servicing the system. Observe all safety procedures when performing a procedure. Unless instructed otherwise, always power off the system or expansion tower where the field-replaceable unit (FRU) is located. See [Powering on and powering off](#) before removing, exchanging, or installing a FRU.

- **OPCIP03**

Use this procedure to isolate a bringup failure with Operations Console.

Parent topic: [Isolation procedures](#)

---

## OPCIP03

Use this procedure to isolate a bringup failure with Operations Console.

**DANGER**When working on or around the system, observe the following precautions:

Electrical voltage and current from power, telephone, and communication cables are hazardous. To avoid a shock hazard:

- Connect power to this unit only with the provided power cord. Do not use the provided power cord for any other product.
- Do not open or service any power supply assembly.
- Do not connect or disconnect any cables or perform installation, maintenance, or reconfiguration of this product during an electrical storm.
- The product might be equipped with multiple power cords. To remove all hazardous voltages, disconnect all power cords.
- Connect all power cords to a properly wired and grounded electrical outlet. Ensure that the outlet supplies proper voltage and phase rotation according to the system rating plate.
- Connect any equipment that will be attached to this product to properly wired outlets.
- When possible, use one hand only to connect or disconnect signal cables.
- Never turn on any equipment when there is evidence of fire, water, or structural damage.
- Disconnect the attached power cords, telecommunications systems, networks, and modems before you open the device covers, unless instructed otherwise in the installation and configuration procedures.
- Connect and disconnect cables as described in the following procedures when installing, moving, or opening covers on this product or attached devices.

To Disconnect:

1. Turn off everything (unless instructed otherwise).
2. Remove the power cords from the outlets.
3. Remove the signal cables from the connectors.
4. Remove all cables from the devices

To Connect:

1. Turn off everything (unless instructed otherwise).
2. Attach all cables to the devices.
3. Attach the signal cables to the connectors.
4. Attach the power cords to the outlets.
5. Turn on the devices.

(D005)

Use this procedure to isolate an Operations Console bringup failure when the SRC on the panel is A6xx5008 or B6xx5008. If you are not using the Operations Console, see A6005004. This procedure only works with cable-connected and LAN configurations. It is not valid for dial connected configurations. Read the danger notices in [Operations Console isolation procedures](#) before proceeding.

1. If the system has logical partitions, perform this procedure from the logical partition that reported the problem. To determine if the system has logical partitions, go to Determine if the system has logical partitions before continuing with this procedure.
2. Is the SRC on the panel A6xx5008 or B6xx5008?
  - ◆ **No: This ends the procedure.**
  - ◆ **Yes:** Are you connecting Operations Console using the ASYNC adapter?
    - ◇ **Yes:** Continue with the next step.
    - ◇ **No:** You are connecting using a LAN adapter. Go to step 6.
3. Are words 17, 18, and 19 all equal to 00000000?
  - ◆ **Yes:** Report the problem to your next level of support. **This ends the procedure.**
  - ◆ **No:** Is word 17 equal to 00000001?
    - ◇ **No:** Continue with the next step.
    - ◇ **Yes:** The ASYNC adapter was not detected. Ensure that the ASYNC adapter card is installed, or replace the IOA and try again. **This ends the procedure.**
4. Is word 17 equal to 00000002?
  - ◆ **Yes:** On the ASYNC adapter card that was found, no cable was detected. Word 18 contains the card position. Locate the ASYNC adapter card in this card position, and ensure that the external cable is attached. Install or replace the external cable. **This ends the procedure.**
  - ◆ **No:** Is word 17 equal to 00000003?
    - ◇ **No:** Continue with the next step.
    - ◇ **Yes:** The cable that was detected does not have the correct cable ID. Word 18 contains the card position. Word 19 contains the cable ID. Locate the ASYNC adapter card in this card position, and verify that the correct cable is attached, or replace the cable. **This ends the procedure.**

5. Is word 17 equal to 00000004?
- ◆ **No:** Report the problem to you next level of support. **This ends the procedure.**
  - ◆ **Yes:** Operations Console failed to make a connection because the port is already being used. Word 18 contains the card position. Disconnect the active communications session and try using the resource again. **This ends the procedure.**
6. Are words 13, 14 and 15 all equal to 00000000?
- ◆ **Yes:** Report the problem to you next level of support. **This ends the procedure.**
  - ◆ **No:** Is word 13 equal to 00000002?
    - ◇ **No:** Continue with the next step.
    - ◇ **Yes:** The LAN hardware failed to activate. Replace the LAN IOA being used. **This ends the procedure.**
7. Is word 13 equal to 00000003?
- ◆ **No:** Continue with the next step.
  - ◆ **Yes:** A hardware error occurred. Word 14 contains the error code, (example: 53001A80). Word 15 contains the card position.
- Is the error code equal to 53001A80?
- ◇ **Yes:** The network cable is not attached to the LAN adapter, the cable is defective, or the network is not operational. **This ends the procedure.**
  - ◇ **No:** The LAN adapter hardware is not operational. Replace the hardware and try again. **This ends the procedure.**
8. Is word 13 equal to 00000004?
- ◆ **Yes:** The console did not respond. Word 14 contains the number of attempts made. Word 15 contains the card position. The system is inserted into the network but there is no connection to the client (PC). Verify the configuration for the network at the system and client; verify the configuration of Operations Console. **This ends the procedure.**
  - ◆ **No:** Is word 13 equal to 00000005?
    - ◇ **No:** Report the problem to your next level support. **This ends the procedure.**
    - ◇ **Yes:** IP information was received from the console. Word 14 contains the received IP address. Verify the configuration data for the client (PC) or verify the configuration for the network. **This ends the procedure.**

**Parent topic:** [Operations Console isolation procedures](#)

---

## Power isolation procedures

Contains procedures for isolating a problem in the power system.

Some field replaceable units (FRUs) can be replaced with the unit powered on. Follow the instructions in [Removing and replacing parts](#) when directed to remove, exchange, or install a FRU.

The following safety notices apply throughout the power isolation procedures. Please read all safety procedures before servicing the system and observe all safety procedures when performing a procedure.

### **DANGER**When working on or around the system, observe the following precautions:

Electrical voltage and current from power, telephone, and communication cables are hazardous. To avoid a shock hazard:

- Connect power to this unit only with the provided power cord. Do not use the provided power cord for any other product.
- Do not open or service any power supply assembly.
- Do not connect or disconnect any cables or perform installation, maintenance, or reconfiguration of this product during an electrical storm.
- The product might be equipped with multiple power cords. To remove all hazardous voltages, disconnect all power cords.
- Connect all power cords to a properly wired and grounded electrical outlet. Ensure that the outlet supplies proper voltage and phase rotation according to the system rating plate.
- Connect any equipment that will be attached to this product to properly wired outlets.
- When possible, use one hand only to connect or disconnect signal cables.
- Never turn on any equipment when there is evidence of fire, water, or structural damage.

- Disconnect the attached power cords, telecommunications systems, networks, and modems before you open the device covers, unless instructed otherwise in the installation and configuration procedures.
- Connect and disconnect cables as described in the following procedures when installing, moving, or opening covers on this product or attached devices.

To Disconnect:

1. Turn off everything (unless instructed otherwise).
2. Remove the power cords from the outlets.
3. Remove the signal cables from the connectors.
4. Remove all cables from the devices

To Connect:

1. Turn off everything (unless instructed otherwise).
2. Attach all cables to the devices.
3. Attach the signal cables to the connectors.
4. Attach the power cords to the outlets.
5. Turn on the devices.

(D005)

- **PWR1900**  
Contains a procedural index based on model.
- **PWR1902**  
A system unit power supply load fault is occurring.
- **PWR1903**  
A system unit power supply load fault is occurring.
- **PWR1904**  
A power supply or regulator overcurrent fault is occurring in the server.
- **PWR1906**  
The server detected an error in the power system.
- **PWR1907**  
A unit was dropped from the SPCN configuration.
- **PWR1908**  
A power supply fault or load fault has occurred in a 50/88 or 05/88 expansion unit.
- **PWR1909**  
A power supply load fault is occurring in a system expansion unit or I/O tower.
- **PWR1911**  
You are here because of a power problem on a dual line cord system. If the failing unit does not have a dual line cord, return to the procedure that sent you here or go to the next item in the FRU list.
- **PWR1912**  
The server detected an error in the power system.
- **PWR1915**  
Use this procedure after observing a system reference code (SRC) of 1xxx 8440 on an ESCALA PL 250T/R with Quiet Office Accoustic conversion or a 112/85.
- **PWR1917**  
Displaying or changing the configuration ID.
- **PWR1918**  
A voltage regulator card might be failing.
- **PWR1920**  
Use this procedure to verify that the lights on the server control panel and the display panel on all attached I/O expansion units are operating correctly.
- **PWR2402**  
The server detected an error in the power system.

Parent topic: [Isolation procedures](#)

---

## PWR1900

Contains a procedural index based on model.

Follow the instructions for the model or expansion unit you are servicing.

- For Models 112/85, ESCALA PL 250R-VL or ESCALA PL 450R-XS, ESCALA PL 250R-L, PL 250R-L+ or PL 450R-VL+, ESCALA PL 250T/R, PL 250T/R+ or PL 450T/R-L+, , perform [PWR1902](#).

- For Models ESCALA PL 450T/R, PL 450T/R+ or PL 850T/R-L+, perform [PWR1903](#).
- For Models ESCALA PL 1650R-L+ and ESCALA PL 850R/PL 1650R/R+ perform [PWR1904](#).
- For 50/74, 50/79, 50/94, and 52/94 units perform [PWR1906](#).
- For 50/88 and 05/88 units perform [PWR1908](#).
- For 50/95, 05/95, 57/90, 11D/10, 11D/11, and 11D/20 units, perform [PWR1909](#).

**This ends the procedure.**

**Parent topic:** [Power isolation procedures](#)

---

## PWR1902

A system unit power supply load fault is occurring.

Please see [Power isolation procedures](#) for important safety information before servicing the system.

**Parent topic:** [Power isolation procedures](#)

**PWR1902 instructions for models ESCALA PL 250R-VL or ESCALA PL 450R-XS, ESCALA PL 250R-L, PL 250R-L+ or PL 450R-VL+, ESCALA PL 250T/R, PL 250T/R+ or PL 450T/R-L+, 7/10**

1. Perform the following steps:
  - a. Disconnect the AC power cable or cables from the unit on which you are working.
  - b. Disconnect all of the I/O devices (tape, diskette, optical, and disk units) by sliding them partially out of the system unit (see [Removing and replacing parts](#)).
  - c. Remove and label all cards (for example, PCI adapters, memory DIMMs, GX adapter(s), RIO/HSL and RAID cards if installed).
  - d. If the SRC is 1xxx-1B01, also remove the regulators (see [Finding part locations](#)).
  - e. Reconnect the AC power cable or cables to the unit on which you are working.
  - f. Power on the system (see [Powering on and powering off](#)).

Does a power reference code occur?

  - ◆ Yes: Continue with the next step.
  - ◆ No: Go to step 6.
2. Perform the following:
  - a. Remove one of the fans from the system unit (if you have previously removed and reinstalled any fans using this procedure, remove one of the fans that has not been removed).

**Note:** Disregard a fan reference code if it occurs during this step.

  - b. Power on the system (see [Powering on and powering off](#)).

Does a power reference code occur?

  - ◆ Yes: Continue with the next step.
  - ◆ No: The fan you removed in this step is the failing item. Replace the failing fan, go to [Removing and replacing parts](#). This ends the procedure.
3. Have you tried removing each fan one at a time?
  - ◆ Yes: Reinstall all the fans and continue with the next step.
  - ◆ No: Perform the following:
    - a. Power off the system (see [Powering on and powering off](#)).
    - b. Install the fan that you removed in step 2 to its original location.
    - c. Repeat step 2.
4. Perform the following:
  - a. Power off the system (see [Powering on and powering off](#)).
  - b. Disconnect the power cable from and then remove one of the power supplies (that you have not already tried removing) from the system unit and replace it with a new one (see [Part number catalog](#)).
  - c. Power on the system (see [Powering on and powering off](#)).

Does a power reference code occur?

- ◆ No: The power supply you just removed and replaced is the failing item. Power off the system (see [Powering on and powering off](#)) and reinstall the parts you removed in previous steps. Go to [Verifying the repair](#). This ends the procedure.
  - ◆ Yes: Continue with the next step.
5. Remove the new power supply that you just installed in step 4 and reinstall the original power supply. Have you now tried exchanging all of the power supplies in the system?
    - ◆ No: Repeat step 4.
    - ◆ Yes: Replace the backplane (see symbolic FRU [SYSBKPL](#)). Then reinstall the parts you removed in step 1. Go to [Verifying the repair](#). This ends the procedure.
  6. Perform the following steps:
    - a. If you removed regulators in step 1, reinstall all of the regulators. If not, go to step 9.
    - b. Power on the system (see [Powering on and powering off](#)).
 Does a power reference code occur?
    - ◆ Yes: Continue with the next step.
    - ◆ No: Go to step 9.
  7. Perform the following:
    - a. Power off the system (see [Powering on and powering off](#)).
    - b. Disconnect one of the regulators you reinstalled in step 6.
    - c. Power on the system (see [Powering on and powering off](#)).
 Does a power reference code occur?
    - ◆ Yes: Continue with the next step.
    - ◆ No: Replace the last regulator you disconnected in this step (see [Removing and replacing parts](#)). This ends the procedure.
  8. Have you disconnected all the regulators?
    - ◆ No: Repeat step 7.
    - ◆ Yes: Reinstall all of the parts removed in this procedure and go to [Start of call procedure](#). This ends the procedure.
  9. Perform the following:
    - a. Reinstall all of the cards (PCI adapters, memory DIMMs, GX adapter(s), RIO/HSL and RAID cards) you removed in step 1.
    - b. Power on the system (see [Powering on and powering off](#)).
 Does a power reference code occur?
    - ◆ Yes: Continue with the next step.
    - ◆ No: Go to step 12.
  10. Perform the following:
    - a. Power off the system (see [Powering on and powering off](#)).
    - b. Disconnect one of the cards you reinstalled in step 9.
    - c. Power on the system (see [Powering on and powering off](#)).
 Does a power reference code occur?
    - ◆ Yes: Continue with the next step.
    - ◆ No: Replace the last card you disconnected in this step (see [Removing and replacing parts](#)). This ends the procedure.
  11. Have you disconnected all the cards?
    - ◆ No: Repeat step 10.
    - ◆ Yes: Reinstall all of the parts removed in this procedure and return to [Start of call procedure](#). This ends the procedure.
  12. Perform the following:
    - a. Power off the system (see [Powering on and powering off](#)).
    - b. Reconnect all of the I/O devices (tape, diskette, optical, or disk units) that you disconnected in step 1.
    - c. Power on the system (see [Powering on and powering off](#)).
 Does a power reference code occur?
    - ◆ Yes: Continue with the next step.
    - ◆ No: The system is working. The problem seems to be intermittent (see [Intermittent problems](#)). This ends the procedure.
  13. Perform the following:
    - a. Power off the system (see [Powering on and powering off](#)).
    - b. Disconnect one of the I/O devices (tape, diskette, optical, or disk units) that you reconnected in step 12.
    - c. Power on the system (see [Powering on and powering off](#)).
 Does a power reference code occur?

- ◆ Yes: Continue with the next step.
  - ◆ No: Replace the last I/O device you disconnected in this step (see [Removing and replacing parts](#)). This ends the procedure.
14. Have you disconnected all the I/O devices?
- ◆ No: Repeat step 13.
  - ◆ Yes: Reinstall all of the parts you removed in this procedure and return to [Start of call procedure](#). This ends the procedure.

## PWR1903

A system unit power supply load fault is occurring.

Please see [Power isolation procedures](#) for important safety information before servicing the system.

**Parent topic:** [Power isolation procedures](#)

Instructions for Models ESCALA PL 450T/R, PL 450T/R+ or PL 850T/R-L+

1. Perform the following (see [Locations Model ESCALA PL 450T/R](#) for links to exchange procedures when asked to remove a part):
  - a. Power off the system (see [Powering on and powering off](#)).
  - b. Disconnect the ac power cable(s) from the unit on which you are working.
  - c. Disconnect all of the I/O devices (tape, diskette, optical, and disk units) by sliding them partially out of the system unit.
  - d. Remove and label all cards (PCI, and RAID cards if installed).
  - e. If the SRC is 1xxx-1B01, also remove the voltage regulators located in P1-C10 and P1-C11 (if installed).
  - f. Reconnect the ac power cable(s) to the unit on which you are working.
  - g. Power on the system (see [Powering on and powering off](#)).

Does a power reference code occur?

  - ◆ Yes: Continue with the next step.
  - ◆ No: Go to step 8.
2. Perform the following:
  - a. Power off the system (see [Powering on and powering off](#)).
  - b. Replace one of the processor cards (see [Locations Model ESCALA PL 450T/R](#)).
  - c. Power on the system (see [Powering on and powering off](#)).

Does the problem persist?

  - ◆ No: This ends the procedure.
  - ◆ Yes: Continue with the next step.
3. Have you replaced all of the processor cards?
  - ◆ No: Repeat step 2 and replace the next processor card.
  - ◆ Yes: Continue with the next step.
4. Perform the following:
  - a. Power off the system (see [Powering on and powering off](#)).
  - b. Remove one of the air moving devices (AMDs) from the system unit (see [Locations Model ESCALA PL 450T/R](#)).

**Note:** Disregard any AMD reference codes that occur during this step.

- c. Power on the system (see [Powering on and powering off](#)).

Does a power reference code occur?

- ◇ Yes: Continue with the next step.
- ◇ No: The AMD you removed is the failing item, and should be replaced (see [Locations Model ESCALA PL 450T/R](#)). This ends the procedure.

5. Have you tried removing each of the AMDs?
  - ◆ Yes: Reinstall all of the AMDs and continue with the next step.
  - ◆ No: Perform the following:
    - a. Power off the system (see [Powering on and powering off](#)).
    - b. Reinstall the AMD that you removed in step 4.
    - c. Repeat step 4.
6. Perform the following:
  - a. Power off the system (see [Powering on and powering off](#)).
  - b. Replace one of the power supplies from the system unit (see [Locations Model ESCALA PL 450T/R](#)).
  - c. Power on the system (see [Powering on and powering off](#)).

Does a power reference code occur?

  - ◆ Yes: Continue with the next step.
  - ◆ No: The power supply you replaced is the failing item. Power off the system and reinstall any other parts you have removed in this procedure. This ends the procedure.
7. Reinstall the original power supply that you replaced in step 6.

Have you now tried to replace each of the power supplies?

- ◆ No: Repeat step 6 and replace the next power supply.
  - ◆ Yes: Replace the backplane (see symbolic FRU [SYSBKPL](#)). Then reinstall the parts you removed in step 1. This ends the procedure.
8. Did you remove any voltage regulators in step 1?
    - ◆ Yes: Continue with the next step.
    - ◆ No: Go to step 12.
  9. Perform the following:
    - a. Power off the system (see [Powering on and powering off](#)).
    - b. Reinstall all of the regulators.
    - c. Power on the system (see [Powering on and powering off](#)).

Does a power reference code occur?

    - ◆ Yes: Continue with the next step.
    - ◆ No: Go to step 12.
  10. Perform the following:
    - a. Power off the system (see [Powering on and powering off](#)).
    - b. Disconnect one of the regulators you reinstalled in step 9.
    - c. Power on the system (see [Powering on and powering off](#)).

Does a power reference code occur?

    - ◆ Yes: Continue with the next step.
    - ◆ No: The regulator you just disconnected is the failing item and should be replaced (see [Locations Model ESCALA PL 450T/R](#)). This ends the procedure.
  11. Have you tried disconnecting each of the voltage regulators?
    - ◆ No: Reconnect the regulator you just disconnected, and then repeat step 10 and try disconnecting the next regulator.
    - ◆ Yes: Reconnect the regulator your disconnected in this step and then continue with the next step.
  12. Perform the following:
    - a. Power off the system (see [Powering on and powering off](#)).
    - b. Reinstall all of the cards you removed in step 1.
    - c. Power on the system (see [Powering on and powering off](#)).

Does a power reference code occur?

    - ◆ Yes: Continue with the next step.
    - ◆ No: Go to step 15.
  13. Perform the following:
    - a. Power off the system (see [Powering on and powering off](#)).
    - b. Disconnect one of the cards you reinstalled in step 12.
    - c. Power on the system (see [Powering on and powering off](#)).

Does a power reference code occur?

    - ◆ Yes: Continue with the next step.
    - ◆ No: The card you just disconnected is the failing item and should be replaced (see [Locations Model ESCALA PL 450T/R](#)). This ends the procedure.
  14. Have you tried disconnecting each of the cards?



- ◆ No: Reconnect the card you just disconnected. Then repeat step 13 and try disconnecting the next card.
  - ◆ Yes: Reinstall all of the parts you've removed in this procedure and continue with the next step.
15. Perform the following:
- a. Power off the system (see [Powering on and powering off](#)).
  - b. Reinstall all of the I/O devices you disconnected in step 1.
  - c. Power on the system (see [Powering on and powering off](#)).
- Does a power reference code occur?
- ◆ Yes: Continue with the next step.
  - ◆ No: The problem appears to be intermittent. Go to [Intermittent problems](#). This ends the procedure.
16. Perform the following:
- a. Power off the system (see [Powering on and powering off](#)).
  - b. Remove one of the I/O devices you reinstalled in step 15.
  - c. Power on the system (see [Powering on and powering off](#)).
- Does a power reference code occur?
- ◆ Yes: Continue with the next step.
  - ◆ No: The device you just removed is the failing item and should be replaced (see [Locations Model ESCALA PL 450T/R](#)). This ends the procedure.
17. Have you tried removing each of the I/O devices?
- ◆ No: Reinstall the I/O device you just removed. Then repeat step 16 and remove the next I/O device.
  - ◆ Yes: Reinstall all of the parts you've removed in this procedure and contact your next level of support. This ends the procedure.

## PWR1904

A power supply or regulator overcurrent fault is occurring in the server.

Refer to [Power isolation procedures](#) for important safety information before servicing the system.

**Parent topic:** [Power isolation procedures](#)

Instructions for Model ESCALA PL 1650R-L+, and ESCALA PL 850R/PL 1650R/R+

1. Is the reference code 1xxx 1C02, 1C04, or 1C06?
  - ◆ Yes: Continue with the next step.
  - ◆ No: Go to step 5.
2. Is the reference code 1xxx 1C02 or 1C04?
  - ◆ No: Continue with the next step.
  - ◆ Yes: Go to step 4.
3. Perform the following:
  - a. Power off the system.
  - b. Replace one of the memory DIMMs on the processor cards (see [Locations model ESCALA PL 1650R-L+ and ESCALA PL 850R/PL 1650R/R+](#)).
  - c. Power on the system.
  - d. Has this resolved the problem?
    - ◇ No: Continue with step 3.e.
    - ◇ Yes: This ends the procedure.
  - e. Have you replaced all of the DIMMs?
    - ◇ No: Repeat step 3 and replace the next memory DIMM.
    - ◇ Yes: Go to step 4.
4. Perform the following:
  - a. Power off the system.

- b. Replace one of the processor cards (see [Locations](#) [model ESCALA PL 1650R-L+ and ESCALA PL 850R/PL 1650R/R+](#)).
- c. Power on the system.
- d. Has this resolved the problem?
  - ◇ No: Continue with step [4.e](#).
  - ◇ Yes: This ends the procedure.
- e. Have you replaced all of the processor cards?
  - ◇ No: Repeat step [4](#) and replace the next processor card.
  - ◇ Yes: Go to step [8](#).

5. Perform the following:

- a. Power off the system and disconnect the ac power cable from the unit you are working on.
- b. Disconnect all of the I/O devices (tape, diskette, optical, and disk units) from the unit you are working on by sliding them partially out of the unit (see [Locations](#) [model ESCALA PL 1650R-L+ and ESCALA PL 850R/PL 1650R/R+](#)).
- c. Remove and label all cards (for example, PCI adapters, memory DIMMs, GX adapter(s), RIO/HSL and RAID cards if installed).
- d. Reconnect the ac power cable to the unit you are working on.
- e. Power on the system.

Does a power reference code occur?

- ◆ Yes: Continue with the next step.
- ◆ No: Go to step [10](#).

6. Perform the following:

- a. Power off the system.
- b. Replace one of the system fans (see [Locations](#) [model ESCALA PL 1650R-L+ and ESCALA PL 850R/PL 1650R/R+](#)).
- c. Power on the system.

Does a power reference code occur?

- ◆ Yes: Continue with the next step.
- ◆ No: The fan you just replaced was the failing item.

This ends the procedure.

7. Have you tried replacing all of the fans?

- ◆ Yes: Reinstall all of the fans you replaced in step [6](#) and continue with the next step.
- ◆ No: Perform the following:
  - a. Power off the system.
  - b. Reinstall the fan that you just removed in step [6](#) to its original location.
  - c. Repeat step [6](#).

8. Perform the following:

- a. Power off the system.
- b. Replace one of the voltage regulator cards. See [Locations](#) [model ESCALA PL 1650R-L+ and ESCALA PL 850R/PL 1650R/R+](#)
- c. Power on the system.

Does a power reference code occur?

- ◆ Yes: Continue with the next step.
- ◆ No: The voltage regulator card you just replaced was the failing item.

This ends the procedure.

9. Have you tried replacing all of the voltage regulator cards?

- ◆ Yes: Replace the regulator distribution connection backplane (see [SYSBKPL](#)). This ends the procedure.
- ◆ No: Perform the following:
  - a. Power off the system.
  - b. Reinstall the voltage regulator card that you just removed in step [8](#) to its original location.
  - c. Repeat step [8](#).

10. Perform the following:

- a. Power off the system.
- b. Reinstall all of the cards (PCI adapters, memory DIMMs, GX adapter(s), RIO/HSL and RAID cards) you removed in step [5](#) to their original locations.
- c. Power on the system.

Does a power reference code occur?

- ◆ Yes: Continue with the next step.
- ◆ No: Go to step [13](#).

11. Perform the following:
    - a. Power off the system.
    - b. Disconnect one of the cards you reinstalled in step 10.
    - c. Power on the system.

Does a power reference code occur?

    - ◆ Yes: Continue with the next step.
    - ◆ No: Exchange the last card you disconnected in this step (see [Locations model ESCALA PL 1650R-L+ and ESCALA PL 850R/PL 1650R/R+](#)). This ends the procedure.
  12. Have you disconnected all of the cards?
    - ◆ No: Repeat step 11.
    - ◆ Yes: Reinstall all of the parts you have removed or exchanged in this procedure and return to [Start of call procedure](#). This ends the procedure.
  13. Perform the following:
    - a. Power off the system.
    - b. Reconnect all of the I/O devices (tape, diskette, optical, and disk units) that you disconnected in step 5.
    - c. Power on the system.

Does a power reference code occur?

    - ◆ Yes: Continue with the next step.
    - ◆ No: The problem has been resolved. This ends the procedure.
  14. Perform the following:
    - a. Power off the system.
    - b. Disconnect one of the I/O devices (tape, diskette, optical, and disk units) that you reconnected in step 13.
    - c. Power on the system.

Does a power reference code occur?

    - ◆ Yes: Continue with the next step.
    - ◆ No: Exchange the last I/O device you disconnected in this step (see [Locations model ESCALA PL 1650R-L+ and ESCALA PL 850R/PL 1650R/R+](#)). This ends the procedure.
  15. Have you tried disconnecting all of the I/O devices?
    - ◆ No: Repeat step 14.
    - ◆ Yes: Reinstall all of the parts you have removed or exchanged in this procedure and return to [Start of call procedure](#). This ends the procedure.
- 

## PWR1906

The server detected an error in the power system.

Please see [Power isolation procedures](#) for important safety information before servicing the system.

**Parent topic:** [Power isolation procedures](#)

**PWR1906 Instructions for 50/74, 50/79, 50/94, and 52/94 expansion units**

1. Perform the following:
  - a. Power off the unit you are working on.
  - b. Disconnect all the I/O devices (tape, diskette, optical, and disk units) from the unit that you are working on by sliding them partially out of the unit. See [Removing and replacing parts](#).
  - c. Remove and label all of the cards that are installed in the PCI card area.
  - d. Power on the unit you are working on.

Does a power reference code occur?

  - ◆ **Yes:** Continue with the next step.
  - ◆ **No:** Go to step 9.
2. Perform the following:
  - a. Power off the unit you are working on.
  - b. Remove, in order, all power supplies except first one (either P00 or P01 depending on the configuration).

- c. Power on the unit you are working on.  
Does a power reference code occur?

- ◆ **Yes:** Continue with the next step.
- ◆ **No:** Go to step 4.

3. Perform the following:
- a. Power off the unit you are working on.
  - b. Remove the power supply that was left installed in step 2.
  - c. Reconnect the next power supply in order (P01 or P02).
  - d. Power on the unit you are working on.

Does a power reference code occur?

- ◆ **Yes:** Go to step 5.
- ◆ **No:** Exchange the power supply you removed in step 3.b (see [Part number catalog](#)).

**This ends the procedure.**

4. Perform the following:
- a. Power off the unit you are working on.
  - b. Reconnect the next power supply in order.
  - c. Power on the unit you are working on.

Does a power reference code occur?

- ◆ **No:** Repeat this step until all power supplies have been reconnected.

**This ends the procedure.**

- ◆ **Yes:** Exchange the power supply that you reconnected in this step (see [Part number catalog](#)).

**This ends the procedure.**

5. Perform the following:
- a. Remove one of the fans from the unit you are working on that you did not previously remove during this procedure.

**Note:** Disregard a fan reference code if it occurs during this step.

- b. Power on the unit you are working on.

Does a power reference code occur?

- ◆ **Yes:** Continue with the next step.
- ◆ **No:** The fan that you removed in this step is the failing item (see [Part number catalog](#)).

**This ends the procedure.**

6. Have you removed all of the fans, one at a time?
- ◆ **Yes:** Install all of the fans and continue with the next step.
  - ◆ **No:** Perform the following:
    - a. Power off the unit you are working on.
    - b. Reinstall the fan that was removed in step 5 to its original location.
    - c. Repeat step 5.

7. Perform the following:
- a. Remove the power cable (that was not previously removed) from one of the lower DASD backplanes.
  - b. Power on the unit you are working on.

Does a power reference code occur?

- ◆ **Yes:** Continue with the next step.
- ◆ **No:** Replace the DASD backplane that the power cable was removed from in this step (see [Part number catalog](#)).

**This ends the procedure.**

8. Is a second lower DASD backplane installed?
- ◆ **Yes:** Repeat step 7.
  - ◆ **No:** Replace the following one at a time:
    - a. DASD backplane upper (DEVBPLN, see [Part number catalog](#)).
    - b. I/O tower unit backplane (TWRCARD, see [Part number catalog](#)).

**This ends the procedure.**

9. Perform the following:
- a. Power off the unit you are working on.

- b. Reinstall all of the cards that you removed in step 1.
- c. Reconnect the ac power cable to the unit that you are working on.
- d. Power on the unit you are working on.

Does a power reference code occur?

- ◆ **Yes:** Continue with the next step.
- ◆ **No:** Go to step 12.

10. Perform the following:

- a. Power off the unit you are working on.
- b. Disconnect one of the cards that you connected in step 9.
- c. Power on the unit you are working on.

Does a power reference code occur?

- ◆ **Yes:** Continue with the next step.
- ◆ **No:** Exchange the last card that you disconnected in this step (see [Part number catalog](#)).

**This ends the procedure.**

11. Have you disconnected all the cards?

- ◆ **Yes:** Continue with the next step.
- ◆ **No:** Repeat step 10.

12. Perform the following:

- a. Power off the unit you are working on.
- b. Reconnect all of the I/O devices (tape, diskette, optical, or disk units) that you disconnected in step 1.
- c. Power on the unit you are working on.

Does a power reference code occur?

- ◆ **Yes:** Continue with the next step.
- ◆ **No: This ends the procedure.**

13. Perform the following:

- a. Power off the unit you are working on.
- b. Disconnect all of the I/O devices (tape, diskette, optical, or disk units) if you have not already done so that you reconnected in step 12.
- c. Now reconnect one of the I/O devices (tape, diskette, optical, or disk units) that you just disconnected.
- d. Power on the unit you are working on.

Does a power reference code occur?

- ◆ **No:** Continue with the next step.
- ◆ **Yes:** Exchange the last I/O device that you reconnected in this step (see [Part number catalog](#)).

**This ends the procedure.**

14. Have you reconnected all the I/O devices?

- ◆ **Yes: This ends the procedure.**
- ◆ **No:** Repeat step 13 (you can skip part b).

## PWR1907

A unit was dropped from the SPCN configuration.

1. Is the reference code you are working with 1xxx 913B?

- ◆ **No:** Continue with the next step.
- ◆ **Yes:** A system power control network (SPCN) microcode download is needed, but not started due to a policy setting. A manual download needs to be started:
  - ◆ Access the advanced system management interface (ASMI) and select "Configure I/O Enclosures"
  - ◆ Select the enclosure that the reference code has identified as needing the download
  - ◆ Select "Start enclosure microcode update". The SPCN microcode will now be loaded to the enclosure.

This ends the procedure.

2. Is the reference code you are working with 1xxx 90F0?

No:

Return to [Start of call procedure](#).

Yes:

A unit was dropped from the SPCN configuration.

This can be caused by any of the following:

- ◆ The rack or unit has lost all ac or dc power.
  - ◆ The SPCN function in the unit has an error.
  - ◆ The SPCN/RIO frame-to-frame cables or the remote I/O (RIO) adapter card has failed.
3. Using the HMC or ASMI, find the 1xxx 90F0 in the error log (see [Displaying error and event logs](#)). Use the *Show details* option to display the location information for the failing unit.
  4. After locating the failing unit, ensure that the RIO cables are seated correctly, reseal the RIO cables if necessary.

Are the cables connected correctly?

No:

Correctly reconnect the RIO cables, or replace them if necessary. This ends the procedure.

Yes:

Continue with the next step.

5. Are the ac line cords on the failing unit connected properly at both ends?

No:

Reconnect the ac line cords, or replace them if necessary. This ends the procedure.

Yes:

Continue with the next step.

6. Check the voltage at the customer's ac outlet. Is the voltage correct?

No:

Inform the customer that the voltage at the ac power outlet is incorrect. This ends the procedure.

Yes:

Continue with the next step.

7. Are the power supplies functional?

No:

Perform the following:

- a. Refer to [../iphau/locations.htm](#) to determine the location and part number for each power supply, and to find the appropriate procedure for exchanging the power supplies.
- b. Replace each power supply one at a time, until the problem has been resolved.
- c. If the problem persists after replacing all of the power supplies, continue with the next step.

Yes:

Continue with the next step.

8. Replace the SPCN node in the failing unit. Go to symbolic FRU [TWRCARD](#) and perform the procedure. This ends the procedure.

**Parent topic:** [Power isolation procedures](#)

---

## PWR1908

A power supply fault or load fault has occurred in a 50/88 or 05/88 expansion unit.

Please see [Power isolation procedures](#) for important safety information before servicing the system. For location information, see [Locations 50/88 and 05/88 expansion I/O units](#).

**Parent topic:** [Power isolation procedures](#)

**PWR1908 instructions for 50/88 and 05/88 expansion units**

1. Perform the following:
  - a. Power off the frame that you are working on by removing the ac line cords from the power supplies on the expansion unit.
  - b. Remove and label all cards installed in the PCI backplane area.

c. Power on the frame by reconnecting the ac power cables to the unit.  
Does a power reference code occur?

- ◆ Yes: Continue with the next step.
- ◆ No: Go to step 8.

2. Is the reference code 1xxx 2603?

- ◆ No: Continue with the next step.
- ◆ Yes: Replace the PCI backplane (see [TWRCARD](#)).

This ends the procedure.

3. Perform the following:

- a. Power off the frame you are working on by removing the ac line cords from the power supplies on the expansion unit.
- b. Remove power supply P01.
- c. Remove fan assembly B01 from power supply P01 and install it on a new power supply P01 (see [Part number catalog](#)).
- d. Install the new power supply P01.
- e. Power on the frame by reconnecting the ac power cables to the unit you are working on.

Does a power reference code occur?

- ◆ Yes: Continue with the next step.
- ◆ No: The power supply that you replaced in this step was the failing item.

This ends the procedure.

4. Perform the following:

- a. Power off the frame you are working on by removing the ac line cords from the power supplies on the expansion unit.
- b. Remove the new power supply P01 and replace it with the original power supply P01.
- c. Remove power supply P02.
- d. Remove fan assembly B02 from power supply P02 and install it on a new power supply P02.
- e. Install the new power supply P02.
- f. Power on the frame by reconnecting the ac power cables to the unit you are working on.

Does a power reference code occur?

- ◆ Yes: Continue with the next step.
- ◆ No: The power supply that you replaced in this step was the failing item.

This ends the procedure.

5. Perform the following:

- a. Power off the frame you are working on by removing the ac line cords from the power supplies on the expansion unit.
- b. Remove both the new power supply P02 and the fan assembly B02.
- c. Reinstall the original power supply P02 and a new fan assembly B02 (see [Part number catalog](#)).
- d. Power on the frame by reconnecting the ac power cables to the unit you are working on.

Does a power reference code occur?

- ◆ Yes: Continue with the next step.
- ◆ No: The fan assembly B02 that you replaced in this step was the failing item.

This ends the procedure.

6. Perform the following:

- a. Power off the frame you are working on by removing the ac line cords from the power supplies on the expansion unit.
- b. Remove power supply P02.
- c. Replace the new fan assembly B02 with the original fan assembly B02.
- d. Reinstall power supply P02.
- e. Remove power supply P01.
- f. Remove fan assembly B01 and replace it with a new fan assembly B01 (see [Part number catalog](#)).
- g. Reinstall power supply P01.
- h. Power on the frame by reconnecting the ac power cables to the unit you are working on.

Does a power reference code occur?

- ◆ Yes: Continue with the next step.
- ◆ No: The fan assembly B01 that you removed in this step is the failing item.

This ends the procedure.

7. Perform the following:
  - a. Power off the frame you are working on by removing the ac line cords from the power supplies on the expansion unit.
  - b. Remove power supply P01.
  - c. Replace fan assembly B01 with the original fan assembly B01.
  - d. Reinstall power supply P01.
  - e. Replace the following FRUs one at a time:
    - ◇ Control panel (see [CTLPNL](#)).
    - ◇ PCI backplane assembly CB1 (see [TWRCARD](#)).

This ends the procedure.

8. Perform the following:
  - a. Power off the frame you are working on by removing the ac line cords from the power supplies on the expansion unit.
  - b. Reinstall one of the cards that you removed in step 1.
  - c. Power on the frame by reconnecting the ac power cables to the unit you are working on.

Does a power reference code occur?

- ◆ No: Continue with the next step.
- ◆ Yes: Exchange the last card that you reinstalled in this step (see [Part number catalog](#)).

This ends the procedure.

9. Have you reinstalled all of the cards?
  - ◆ Yes: Replace the PCI backplane assembly CB1 (see [TWRCARD](#)).

This ends the procedure.

- ◆ No: Repeat step 8, reinstalling the next card.
- 

## PWR1909

A power supply load fault is occurring in a system expansion unit or I/O tower.

Please see [Power isolation procedures](#) for important safety information before servicing the system.

**Parent topic:** [Power isolation procedures](#)

Instructions for 50/95, 05/95, 57/90, 11D/10, 11D/11, 11D/20

1. Perform the following:
  - a. Power off the system.
  - b. Disconnect all the I/O devices (tape, diskette, optical, and disk units) from the expansion unit or I/O tower you are working on by sliding them partially out of the unit (see [Removing and replacing parts](#)).
  - c. Remove and label all cards installed in the PCI card area.
  - d. Power on the system.

Does a power reference code occur?

- ◆ Yes: Continue with the next step.
- ◆ No: Go to step 8.

2. Perform the following:
  - a. Power off the system.
  - b. Remove one of the fans from the expansion unit or I/O tower that you have not previously removed during this procedure.

**Note:** Disregard a fan reference code if it occurs during this step.

- c. Power on the system.

Does a power reference code occur?

- ◆ Yes: Continue with the next step.



- ◆ No: The fan you removed in this step is the failing item (see [Part number catalog](#)).

This ends the procedure.

3. Have you removed all of the fans one at a time?

- ◆ No: Perform the following:
  - a. Power off the system.
  - b. Reinstall the fan that you removed in step 2 into its original location.
  - c. Repeat step 2.
- ◆ Yes: Reinstall all of the fans and continue with the next step.

4. Perform the following:

- a. Power off the system.
- b. Remove the I/O tower power supply cable, at the DASD backplane, that you have not previously removed.
- c. Power on the system.

Does a power reference code occur?

- ◆ No: The DASD backplane that was disconnected in this step is the failing item (see [Part number catalog](#)).

This ends the procedure.

- ◆ Yes: Continue with the next step.

5. Have you disconnected the power cables from each of the DASD backplanes one at a time?

- ◆ Yes: Continue with the next step.
- ◆ No: Repeat step 4.

6. Perform the following:

- a. Power off the system.
- b. Remove a power supply that you have not previously removed, and replace it with a new one.
- c. Power on the system.

Does a power reference code occur?

- ◆ Yes: Continue with the next step.
- ◆ No: The power supply that was removed in this step is the failing item (see [Part number catalog](#)).

This ends the procedure.

7. Have you removed all of the power supplies one at a time?

- ◆ Yes: Perform the following:
  - a. Remove the new power supply that you installed in step 6 and reinstall the original power supply.
  - b. Replace the backplane (see [TWRCARD](#)).

This ends the procedure.

- ◆ No: Remove the new power supply that you installed in step 6 and reinstall the original power supply. Then, repeat step 6.

8. Perform the following:

- a. Power off the system.
- b. Reinstall all of the cards you removed in step 1.
- c. Power on the system.

Does a power reference code occur?

- ◆ Yes: Continue with the next step.
- ◆ No: Go to step 11.

9. Perform the following:

- a. Power off the system.
- b. Disconnect one of the cards you reconnected in step 8.
- c. Power on the system.

Does a power reference code occur?

- ◆ Yes: Continue with the next step.
- ◆ No: Exchange the last card you disconnected in this step (see [Part number catalog](#)).

This ends the procedure.

10. Have you disconnected all the cards?

- ◆ No: Repeat step 9.
- ◆ Yes: Reinstall all the parts and return to [Start of call procedure](#).

This ends the procedure.

11. Perform the following:
  - a. Power off the system.
  - b. Reconnect all of the I/O devices (tape, diskette, optical, or disk units) that you disconnected in step 1.
  - c. Power on the system.

Does a power reference code occur?

- ◆ Yes: Continue with the next step.
- ◆ No: This ends the procedure.

12. Perform the following:
  - a. Power off the system.
  - b. Disconnect one of the I/O devices you reconnected in step 11.
  - c. Power on the system.

Does a power reference code occur?

- ◆ Yes: Continue with the next step.
- ◆ No: Exchange the last I/O device you disconnected in this step (see [Part number catalog](#)).

This ends the procedure.

13. Have you disconnected all of the I/O devices?
  - ◆ No: Repeat step 12.
  - ◆ Yes: Reinstall all the parts and return to [Start of call procedure](#).

This ends the procedure.

## PWR1911

You are here because of a power problem on a dual line cord system. If the failing unit does not have a dual line cord, return to the procedure that sent you here or go to the next item in the FRU list.

The following steps are for the system unit, unless other instructions are given. Please refer to [Power isolation procedures](#) for important safety information before servicing the system.

1. Are you working with a model 5/75, ESCALA PL 3250R or 5/95?
  - ◆ **No:** Continue with the next step.
  - ◆ **Yes:** Go to [PWR1912](#). **This ends the procedure.**
2. If an uninterruptible power supply is installed, verify that it is powered on before proceeding.
3. Are all the units powered on?
  - ◆ **Yes:** Go to step 8.
  - ◆ **No:** On the unit that does not power on, perform the following:
    - a. Disconnect the ac line cords from the unit that does not power on.
    - b. Use a multimeter to measure the ac voltage at the system end of both ac line cords.

Table 1. Correct ac voltage

| Model or expansion unit                                                                                                                                                                                                                                                              | Correct ac voltage           |
|--------------------------------------------------------------------------------------------------------------------------------------------------------------------------------------------------------------------------------------------------------------------------------------|------------------------------|
| Models ESCALA PL 250R-VL or ESCALA PL 450R-XS, ESCALA PL 250R-L, PL 250R-L+ or PL 450R-VL+, ESCALA PL 250T/R, PL 250T/R+ or PL 450T/R-L+, ESCALA PL 450T/R, PL 450T/R+ or PL 850T/R-L+, ESCALA PL 1650R-L+, ESCALA PL 850R/PL 1650R/R+, and 50/95, 05/95, and 11D/20 expansion units | 100V to 127V or 200V to 240V |
| 50/74, 50/79, 50/88, 05/88, 50/94, 52/94, 57/90, 11D/10, and 11D/11 expansion units                                                                                                                                                                                                  | 200V to 240V                 |

- c. Is the ac voltage correct (refer to [Table 1](#))?
- **Yes:** Continue with the next step.
  - **No:** Go to step 7.
4. Are you working on a model ESCALA PL 250R-VL or ESCALA PL 450R-XS, ESCALA PL 250R-L, PL 250R-L+ or PL 450R-VL+, ESCALA PL 250T/R, PL 250T/R+ or PL 450T/R-L+, ESCALA PL 450T/R, PL 450T/R+ or PL 850T/R-L+, ESCALA PL 1650R-L+, ESCALA PL 850R/PL 1650R/R+, 7/10, or a 50/88, 05/88, 50/95, 05/95, 57/90, 11D/10, 11D/11, or 11D/20 expansion unit?
- ◆ **No:** Continue with the next step.
  - ◆ **Yes:** Perform the following:
    - a. Reconnect the ac line cords.
    - b. Verify that the failing system or tower fails to power on.
    - c. Replace the failing power supply. Use the table below to determine which power supply needs replacing, and then see [Finding part locations](#) for its location, part number, and exchange procedure.

Table 2. Failing power supply for models ESCALA PL 250R-VL or ESCALA PL 450R-XS, ESCALA PL 250R-L, PL 250R-L+ or PL 450R-VL+, ESCALA PL 250T/R, PL 250T/R+ or PL 450T/R-L+, ESCALA PL 450T/R, PL 450T/R+ or PL 850T/R-L+, ESCALA PL 1650R-L+, ESCALA PL 850R/PL 1650R/R+, and 50/88, 05/88, 50/95, 05/95, 57/90, 11D/10, 11D/11, 11D/20 expansion units

| Reference code | Models or expansion units                                                                                                                                                                                                             | Failing item name |
|----------------|---------------------------------------------------------------------------------------------------------------------------------------------------------------------------------------------------------------------------------------|-------------------|
| 1510           | ESCALA PL 250R-VL or ESCALA PL 450R-XS, ESCALA PL 250R-L, PL 250R-L+ or PL 450R-VL+, ESCALA PL 250T/R, PL 250T/R+ or PL 450T/R-L+, ESCALA PL 450T/R, PL 450T/R+ or PL 850T/R-L+, ESCALA PL 1650R-L+, ESCALA PL 850R/PL 1650R/R+, 7/20 | Power supply 1    |
|                | 50/88, 05/88                                                                                                                                                                                                                          | Power supply 2    |
|                | 50/95, 05/95, 57/90, 11D/10, 11D/11, 11D/20                                                                                                                                                                                           | Power supply 1    |
| 1520           | ESCALA PL 250R-L, PL 250R-L+ or PL 450R-VL+, ESCALA PL 250T/R, PL 250T/R+ or PL 450T/R-L+, ESCALA PL 450T/R, PL 450T/R+ or PL 850T/R-L+, ESCALA PL 1650R-L+, ESCALA PL 850R/PL 1650R/R+, 7/20                                         | Power supply 2    |
|                | 50/88, 05/88                                                                                                                                                                                                                          | Power supply 1    |
|                | 50/95, 05/95, 57/90, 11D/10, 11D/11, 11D/20                                                                                                                                                                                           | Power supply 2    |

**This ends the procedure.**

5. Perform the following:
- a. Reconnect the ac line cord to the ac modules.
  - b. Remove the ac jumper cables at the power supplies.
  - c. Use a multimeter to measure the ac voltage at the jumper cable power supply end.
- Is the ac voltage from 200V to 240V?
- ◆ **No:** Continue with the next step.
  - ◆ **Yes:** Replace the failing power supply. Use the table below to determine which power supply needs replacing, and then see [Finding part locations](#) for its location, part number, and exchange procedure.

**Attention:** Do not install power supplies P00 and P01 ac jumper cables on the same ac module.

Table 3. Failing power supply for 50/74, 50/79, and 50/94 expansion units

| Reference code | Failing item name           |
|----------------|-----------------------------|
| 1500           | Power supply 0 (50/94 only) |
| 1510           | Power supply 1              |
| 1520           | Power supply 2              |
| 1530           | Power supply 3 (50/94 only) |

**This ends the procedure.**

6. Perform the following:

- a. Disconnect the ac jumper cable at the ac module output.
- b. Use a multimeter to measure the ac voltage at the ac module output.

Is the ac voltage from 200V to 240V?

- ◆ **Yes:** Exchange the ac jumper cable.

**This ends the procedure.**

- ◆ **No:** Exchange the ac module (see [Finding part locations](#)).

**This ends the procedure.**

7. Perform the following:

- a. Disconnect the ac line cords from the customer's ac power outlet.
- b. Use a multimeter to measure the ac voltage at the customer's ac power outlet.

Is the ac voltage correct (refer to [Table 1](#))?

- ◆ **Yes:** Exchange the failing ac line cord.

**This ends the procedure.**

- ◆ **No:** Perform the following:

- a. Inform the customer that the ac voltage at the power outlet is not correct.
- b. Reconnect the ac line cords to the power outlet after the ac voltage at the power outlet is correct.

**This ends the procedure.**

8. Is the reference code 1xxx-00AC?

- ◆ **No:** Continue with the next step.
- ◆ **Yes:** This reference code may have been caused by an ac outage. If the system will power on without an error no parts need to be replaced.

**This ends the procedure.**

9. Is the reference code 1xxx-1510 or 1520?

- ◆ **No:** Continue with the next step.
- ◆ **Yes:** Perform the following:
  - a. Use the following table and [Finding part locations](#) to locate the failing parts.

| Model or expansion unit                                                                   | Reference code | Locate these parts                 |
|-------------------------------------------------------------------------------------------|----------------|------------------------------------|
| ESCALA PL<br>250R-VL or<br>ESCALA PL<br>450R-XS, ESCALA<br>PL 250R-L, PL<br>250R-L+ or PL | 1xxx 1510      | Power supply E1 and ac line cord 1 |
|                                                                                           | 1xxx 1520      | Power supply E2 and ac line cord 2 |

Service provider information

|                                                                                                                                                                                             |           |                                                               |
|---------------------------------------------------------------------------------------------------------------------------------------------------------------------------------------------|-----------|---------------------------------------------------------------|
| 450R-VL+, ESCALA<br>PL 250T/R, PL<br>250T/R+ or PL<br>450T/R-L+,<br>ESCALA PL<br>450T/R, PL<br>450T/R+ or PL<br>850T/R-L+,<br>ESCALA PL<br>1650R-L+, ESCALA<br>PL 850R/PL<br>1650R/R+, 7/20 |           |                                                               |
| 50/88 and 05/88<br>(see <a href="#">Figure 2</a> )                                                                                                                                          | 1xxx 1510 | ac jumper cable connected to power supply 2 and the ac module |
|                                                                                                                                                                                             | 1xxx 1520 | ac jumper cable connected to power supply 1 and the ac module |
| 50/74, 50/79, and<br>50/94 (see <a href="#">Figure 1</a> )                                                                                                                                  | 1xxx 1510 | ac jumper cable connected to power supply 2 and the ac module |
|                                                                                                                                                                                             | 1xxx 1520 | ac jumper cable connected to power supply 1 and the ac module |
| 50/95 and 05/95                                                                                                                                                                             | 1xxx 1510 | Power supply 1 and ac line cord 1                             |
|                                                                                                                                                                                             | 1xxx 1520 | Power supply 2 and ac line cord 2                             |
| 57/90, 11D/10,<br>11D/11, 11D/20                                                                                                                                                            | 1xxx 1510 | Power supply 1 and ac line cord 1                             |
|                                                                                                                                                                                             | 1xxx 1520 | Power supply 2 and ac line cord 2                             |

Figure 1. Dual line cord drawing for 50/94

Service provider information

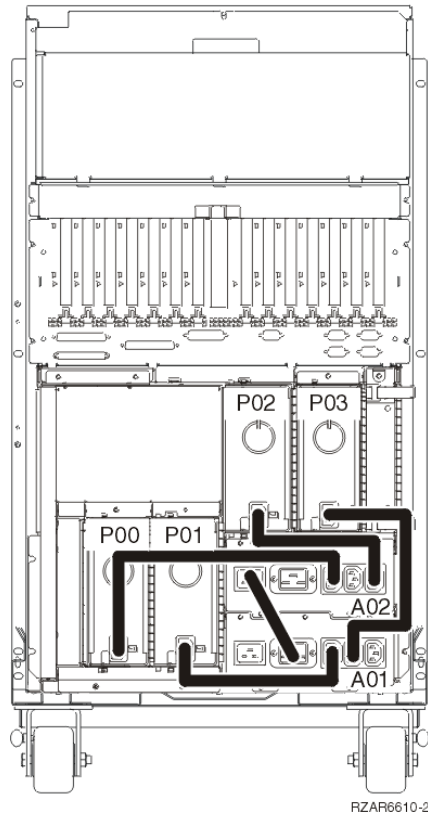
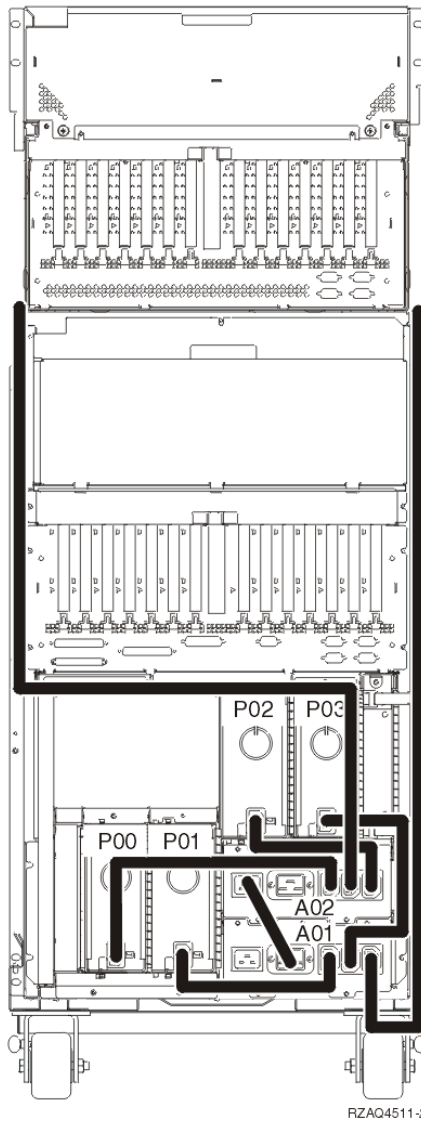


Figure 2. Dual line cord drawing for 50/88, or 05/88 installed on 50/94



b. Locate the ac line cord or the ac jumper cable for the reference code you are working on.

**Attention:** Do not disconnect the other system line cord when powered on.

c. Go to step 11.

10. Is the reference code 1xxx 1500 or 1xxx 1530?

◆ **No:** Return to [Start of call procedure](#).

**This ends the procedure.**

◆ **Yes:** Locate the ac jumper cables for the reference code you are working on, and then continue with the next step:

**Attention:** Do not disconnect the other ac jumper cable when powered on.

◇ If the reference code is 1xxx 1500, see [Locations 50/94, 52/94, and 8094-002 expansion I/O units](#) to determine the locations of ac jumper cables that connect to power supply P00.

◇ If the reference code is 1xxx 1530, see [Locations 50/94, 52/94, and 8094-002 expansion I/O units](#) to determine the locations of ac jumper cables that connect to power supply P03.

## 11. Perform the following:

- a. For the reference code you are working on, disconnect either the ac jumper cable from the power supply **or** the ac line cord from the expansion unit.
- b. Use a multimeter to measure the ac voltage at the power supply end of the ac jumper cable **or** the expansion unit end of the ac line cord.

Is the ac voltage correct (see [Table 1](#))?

- ◆ **No:** Continue with the next step.
- ◆ **Yes:** Exchange the failing power supply. Refer to [Table 2](#) and [Table 3](#) for its position, and then see [Finding part locations](#) for part numbers and directions to the correct exchange procedures. **This ends the procedure.**

## 12. Perform the following:

- a. Disconnect the ac line cords from the power outlet.
- b. Use a multimeter to measure the ac voltage at the customer's ac power outlet.

Is the ac voltage correct (see [Table 1](#))?

- ◆ **Yes:** Exchange the following, one at a time:
  - ◇ failing ac line cord
  - ◇ failing ac jumper cable (if installed)
  - ◇ failing ac module (if installed) (see [Finding part locations](#) for part numbers and directions to the correct exchange procedures)

**This ends the procedure.**

- ◆ **No:** Perform the following:
  - a. Inform the customer that the ac voltage at the power outlet is not correct.
  - b. Reconnect the ac line cords to the power outlet after the ac voltage at the power outlet is correct.

**This ends the procedure.**

Parent topic: [Power isolation procedures](#)

---

## PWR1915

Use this procedure after observing a system reference code (SRC) of 1xxx 8440 on an ESCALA PL 250T/R with Quiet Office Accoustic conversion or a 112/85.

Is your system producing an SRC of 1xxx 8440?

- **No:** Return to the [Start of call procedure](#).
- **Yes:** Only 4 disk drives are supported on an ESCALA PL 250T/R with Quiet Office Accoustic conversion or a 112/85. You must remove the second disk drive backplane or replace it with the passthru backplane. Failure to do so will not allow the system to power up.

**This ends this procedure.**

Parent topic: [Power isolation procedures](#)

---

## PWR1917

Displaying or changing the configuration ID.

1. Use either the advanced system management interface (ASMI) or the control panel to display and change the configuration ID.
  - ◆ If you are using the ASMI, refer to [Changing system configuration](#), and use [Table 1](#) to find the correct configuration ID.
  - ◆ If you are using the control panel continue with the next step.
2. Perform the following to display the configuration ID:

**Attention:** The system or frame that will display the ID must be powered off with ac power applied.



**Notes:**

- ◆ If you have just restored power to the system, the service processor must come back up to standby before control panel functions will work properly. Bringing the service processor back up to standby takes a few minutes **after** the panel appears to be operational.
- ◆ You must have the panel in Manual mode to access function 7 options.

- a. Select function 07 on the system control panel. Press Enter (07\*\* will be displayed).
- b. Use the arrow keys to increment/decrement to subfunction A8. 07A8 will be displayed. Press Enter (07A8 00 will be displayed).
- c. Use the arrow keys to increment/decrement to the first byte of the unit address (usually 3C) for the box you want to check. 07nn (073C, for example) will be displayed, where nn is the first byte of the frame address.
- d. Press Enter (073C 00, for example, will be displayed).
- e. Use the arrow keys to increment/decrement to the second byte of the unit address (usually 01, 02, etc for I/O expansion units and 00 for system unit frames) for the box you want to check. 07nn will be displayed, where nn is the second byte of the frame address (0700, for example, for a system unit frame). Press Enter (0700 00, for example, will be displayed).

**Note:** The display on an addressed I/O expansion should be blinking on and off while displaying the configuration ID as the last two characters of the bottom line.

- f. For a system unit, press an arrow key (increment or decrement) twice to display the ID (first 07\*\* will be displayed, then 07nn will be displayed, where nn is the configuration ID). For example, for a model ESCALA PL 250R-VL or ESCALA PL 450R-XS, 07C0 will be displayed.
- g. Use the following table to check the frame configuration ID.

Table 1. Frame Configuration IDs

| Model or expansion unit                                                                                                                                    | Configuration ID (Processing unit identifier) |
|------------------------------------------------------------------------------------------------------------------------------------------------------------|-----------------------------------------------|
| ESCALA PL 250T/R, PL 250T/R+ or PL 450T/R-L+                                                                                                               | B4                                            |
| ESCALA PL 250T/R, PL 250T/R+ or PL 450T/R-L+ Battery backup                                                                                                | BC                                            |
| ESCALA PL 250R-VL or ESCALA PL 450R-XS                                                                                                                     | C0                                            |
| ESCALA PL 250R-L, PL 250R-L+ or PL 450R-VL+                                                                                                                | BA                                            |
| ESCALA PL 450T/R, PL 450T/R+ or PL 850T/R-L+                                                                                                               | B5                                            |
| ESCALA PL 450T/R, PL 450T/R+ or PL 850T/R-L+ Battery backup                                                                                                | BD                                            |
| 7/20                                                                                                                                                       | BB                                            |
| , 57/96                                                                                                                                                    | 8D                                            |
| ESCALA PL 1650R-L+ and ESCALA PL 850R/PL 1650R/R+                                                                                                          | B2                                            |
| ESCALA PL 1650R-L+ and ESCALA PL 850R/PL 1650R/R+ (if service processor cable is attached to the primary unit or if there are one or more secondary units) | B3                                            |
| 5/75                                                                                                                                                       | B9                                            |
| ESCALA PL 3250R, PL 3250R+, ESCALA PL 6450 or PL 6450R+                                                                                                    | B1                                            |
| 50/74 and 50/79                                                                                                                                            | 81                                            |
| 50/88 and 05/88                                                                                                                                            | 89                                            |
| 50/94 and 52/94                                                                                                                                            | 8A                                            |

Service provider information

|                       |    |
|-----------------------|----|
| 50/95 and 05/95       | 8B |
| 11D/10, 11D/11, 57/90 | 88 |
| 11D/20                | 8C |

**Note:** Processing unit IDs are not applicable for the D24, T24, ESCALA PL 245T/R, and the 471/85.

h. Is the correct configuration ID displayed for the tower selected?

No:

Continue with the next step.

Yes:

Go to step [step 6](#).

3. You need to set the frame configuration ID. Are you starting this step from the function 01 view on the control panel?

No:

To ensure that the control panel operates properly, return to function 01. Do the following:

- The operator panel should still show the incorrect configuration ID (for example, 07C0).
- Press Enter. The control panel will now show 07xx 00 (for example, 07C0 00).
- Use the arrows to display 07xx, then press Enter. The control panel will now show 07.
- Use the arrows to get the display to function 01, then press Enter. You should now be at the regular function 01 control panel view.
- Continue with the next step.

Yes:

Continue with step [step 5](#).

4. Set the frame configuration ID. Do the following:

- Select function 07 on the system control panel. Press Enter (07\*\* will be displayed).
- Use the arrow keys to increment/decrement to subfunction A9 (07A9 will be displayed). Press Enter (07A9 00 will be displayed).
- Use the arrow keys to increment/decrement to the first byte of the unit address (usually 3C) for the box that you want to change. 07nn (073C, for example) will be displayed, where nn is the first byte of the unit address. Press Enter (073C 00, for example, will be displayed).

**Note:** The display on the addressed frame will be blinking on and off (non-system unit frames only).

- Use the arrow keys to increment/decrement to the second byte of the unit address (usually 01, 02, etc for I/O Expansion units and 00 for system unit frames) for the box you want to check. 07nn will be displayed, where nn is the second byte of the frame address (0700, for example, for a system unit frame). Press Enter (0700 00, for example, will be displayed).

**Note:** The display on the addressed I/O expansion unit will be blinking on and off.

- Use the arrow keys to increment/decrement to the correct configuration ID (refer to [Table 1](#)). 07xx will be displayed where xx is the configuration ID.
- Press Enter (07xx 00 will be displayed). After 20 to 30 seconds, the display on the addressed I/O expansion unit will stop blinking and return to the normal display format. On a system unit, the display will show the series of bring-up reference codes and then display function 01.

**Note:** To return the panel to normal display, scroll to 07\*\* and press Enter.

g. Is the reference code 1xxx 840D or 1xxx 840E?

No:

**This ends the procedure.**

Yes:

Continue with the next step.

5. Perform the following:

a. Power off the system.

b. Exchange the SPCN card in the failing frame (see [TWRCARD](#)). **This ends the procedure.**

**Parent topic:** [Power isolation procedures](#)

---

## PWR1918

A voltage regulator card might be failing.

Instructions vary depending on the machine you are servicing. Choose from the following:

- [Instructions for model ESCALA PL 250R-VL or ESCALA PL 450R-XS](#)
- [Instructions for model ESCALA PL 250R-L, PL 250R-L+ or PL 450R-VL+](#)
- [Instructions for model ESCALA PL 250T/R+ or ESCALA PL 450T/R-L+](#)
- [Instructions for model ESCALA PL 250T/R](#)
- [Instructions for model ESCALA PL 450T/R, PL 450T/R+ or PL 850T/R-L+](#)
- [Instructions for model ESCALA PL 1650R-L+ and ESCALA PL 850R/PL 1650R/R+](#)

**Parent topic:** [Power isolation procedures](#)

**Instructions for model ESCALA PL 250R-VL or ESCALA PL 450R-XS**

1. Is the reference code 1xxx 2631?

◆ No: Continue with the next step.

◆ Yes: The 1.5V voltage regulator, which is part of the system backplane, is the failing item. Replace the system backplane (see [Locations](#) [model ESCALA PL 250R-VL or ESCALA PL 450R-XS](#)). This ends the procedure.

2. Is the reference code 1xxx 2632?

◆ No: Continue with the next step.

◆ Yes: The 2.5V voltage regulator, which is part of the system backplane, is the failing item. Replace the system backplane (see [Locations](#) [model ESCALA PL 250R-VL or ESCALA PL 450R-XS](#)). This ends the procedure.

3. Is the reference code 1xxx 2636 or 2637?

◆ No: Return to [Start of call procedure](#). This ends the procedure.

◆ Yes: Continue with the next step.

4. The 1.3V voltage regulator is the failing item and needs to be replaced (see [Locations](#) [model ESCALA PL 250R-VL or ESCALA PL 450R-XS](#)). If you have a 2 way processor, you will have two 1.3V voltage regulators both of which will need to be replaced.

Does the problem persist?

◆ No: This ends the procedure.

◆ Yes: Replace the system backplane (see [Locations](#) [model ESCALA PL 250R-VL or ESCALA PL 450R-XS](#)). This ends the procedure.

**Instructions for model ESCALA PL 250R-L, PL 250R-L+ or PL 450R-VL+**

1. Is the reference code 1xxx 2631?

◆ No: Continue with the next step.

◆ Yes: The 1.5V voltage regulator, which is part of the system backplane, is the failing item. Replace the system backplane (see [Locations](#) [model ESCALA PL 250R-L, ESCALA PL 250R-L+ or ESCALA PL 450R-VL+](#), ). This ends the procedure.

2. Is the reference code 1xxx 2632?

◆ No: Continue with the next step.

- ◆ Yes: The 2.5V voltage regulator is the failing item and needs to be replaced (see [Locations model ESCALA PL 250R-L, ESCALA PL 250R-L+ or ESCALA PL 450R-VL+](#), ). This ends the procedure.
3. Is the reference code 1xxx 2636 or 2637?
    - ◆ No: Return to [Start of call procedure](#). This ends the procedure.
    - ◆ Yes: Continue with the next step.
  4. The 1.3V voltage regulator is the failing item and needs to be replaced (see [Locations model ESCALA PL 250R-L, ESCALA PL 250R-L+ or ESCALA PL 450R-VL+](#), ). If you have a 2 way processor, you will have two 1.3V voltage regulators both of which will need to be replaced.

Does the problem persist?

- ◆ No: This ends the procedure.
- ◆ Yes: Replace the system backplane (see [Locations model ESCALA PL 250R-L, ESCALA PL 250R-L+ or ESCALA PL 450R-VL+](#), ). This ends the procedure.

**Instructions for model 112/85 and ESCALA PL 250T/R+ or ESCALA PL 450T/R-L+**

1. Is the reference code 1xxx 2631?
  - ◆ No: Continue with the next step.
  - ◆ Yes: The voltage regulator for 1.5V is the failing item and needs to be replaced (see [Locations Model 112/85 and ESCALA PL 250T/R+ or ESCALA PL 450T/R-L+](#) to locate and replace the regulator). This ends the procedure.
2. Is the reference code 1xxx 2632?
  - ◆ No: Return to the [Start of call procedure](#). This ends the procedure.
  - ◆ Yes: The voltage regulator for 2.5V is the failing item and needs to be replaced (see [Locations Model 112/85 and ESCALA PL 250T/R+ or ESCALA PL 450T/R-L+](#) to locate and replace the regulator). This ends the procedure.
3. Is the reference code 1xxx 2636 or 2637?
  - ◆ No: Return to the [Start of call procedure](#). This ends the procedure.
  - ◆ Yes: The 1.2V voltage regulator is the failing item and needs to be replaced (see [Locations Model 112/85 and ESCALA PL 250T/R+ or ESCALA PL 450T/R-L+](#). If you have a 2-way processor, you will have two 1.2V voltage regulators, both of which will need to be replaced.
4. Does the problem persist?
  - ◆ No: This ends the procedure.
  - ◆ Yes: Replace the system backplane (see [Locations Model 112/85 and ESCALA PL 250T/R+ or ESCALA PL 450T/R-L+](#)). This ends the procedure.

**Instructions for model ESCALA PL 250T/R**

1. Is the reference code 1xxx 2630?
  - ◆ No: Continue with the next step.
  - ◆ Yes: The voltage regulator for 1.2V is the failing item and needs to be replaced (see [Locations Model ESCALA PL 250T/R](#) to locate and replace the regulator). This ends the procedure.
2. Is the reference code 1xxx 2631?
  - ◆ No: Continue with the next step.
  - ◆ Yes: The voltage regulator for 1.5V is the failing item and needs to be replaced (see [Locations Model ESCALA PL 250T/R](#) to locate and replace the regulator). This ends the procedure.
3. Is the reference code 1xxx 2632?
  - ◆ No: Return to the [Start of call procedure](#). This ends the procedure.
  - ◆ Yes: The voltage regulator for 2.5V is the failing item and needs to be replaced (see [Locations Model ESCALA PL 250T/R](#) to locate and replace the regulator). This ends the procedure.
4. Is the reference code 1xxx 2636 or 2637?
  - ◆ No: Return to the [Start of call procedure](#). This ends the procedure.
  - ◆ Yes: The 1.2V voltage regulator is the failing item and needs to be replaced (see [Locations Model ESCALA PL 250T/R](#). If you have a 2-way processor, you will have two 1.2V voltage regulators, both of which will need to be replaced.
5. Does the problem persist?
  - ◆ No: This ends the procedure.
  - ◆ Yes: Replace the system backplane (see [Locations Model ESCALA PL 250T/R](#)). This ends the procedure.

## Instructions for model ESCALA PL 450T/R, PL 450T/R+ or PL 850T/R-L+

1. Is the reference code 1xxx 2630?
  - ◆ No: Continue with the next step.
  - ◆ Yes: The voltage regulator for 1.3V for processor card 1 is the failing item and needs to be replaced (see [Locations ESCALA PL 450T/R, ESCALA PL 450T/R+ or ESCALA PL 850T/R-L+](#), to locate and replace the regulator). This ends the procedure.
2. Is the reference code 1xxx 2631?
  - ◆ No: Continue with the next step.
  - ◆ Yes: The voltage regulator for 1.5V on system processor card 1 is the failing item and needs to be replaced (see [Locations ESCALA PL 450T/R, ESCALA PL 450T/R+ or ESCALA PL 850T/R-L+](#), to locate and replace the regulator). If the regulator is not pluggable or if the problem is not resolved after you replace this part, exchange system processor card 1. This ends the procedure.
3. Is the reference code 1xxx 2632?
  - ◆ No: Continue with the next step.
  - ◆ Yes: The voltage regulator for 2.5V on system processor card 1 is the failing item and needs to be replaced (see [Locations ESCALA PL 450T/R, ESCALA PL 450T/R+ or ESCALA PL 850T/R-L+](#), to locate and replace the regulator). If this regulator is not pluggable or if the problem is not resolved after you replace this part, exchange the system processor card. This ends the procedure.
4. Is the reference code 1xxx 2640?
  - ◆ No: Continue with the next step.
  - ◆ Yes: The voltage regulator for 1.3V for processor card 2 is the failing item and needs to be replaced (see [Locations ESCALA PL 450T/R, ESCALA PL 450T/R+ or ESCALA PL 850T/R-L+](#), to locate and replace the regulator). If the problem is not resolved after you replace this part, exchange the following parts, one at a time:
    - ◇ service processor
    - ◇ system processor assembly P2
 This ends the procedure.
5. Is the reference code 1xxx 2641?
  - ◆ No: Continue with the next step.
  - ◆ Yes: The voltage regulator for 1.5V on system processor card 2 is the failing item and needs to be replaced (see [Locations ESCALA PL 450T/R, ESCALA PL 450T/R+ or ESCALA PL 850T/R-L+](#), to locate and replace the regulator). If this regulator is not pluggable or if the problem is not resolved after you replace this part, exchange system processor card 2. This ends the procedure.
6. Is the reference code 1xxx 2642?
  - ◆ No: Return to the [Start of call procedure](#). This ends the procedure.
  - ◆ Yes: The voltage regulator for 2.5V on system processor card 2 is the failing item and needs to be replaced (see [Locations ESCALA PL 450T/R, ESCALA PL 450T/R+ or ESCALA PL 850T/R-L+](#), to locate and replace the regulator). If this regulator is not pluggable or if the problem is not resolved after you replace this part, exchange the system processor card. This ends the procedure.

## Instructions for model ESCALA PL 1650R-L+ and ESCALA PL 850R/PL 1650R/R+

1. Is the reference code 1xxx 8450?
  - ◆ No: Continue with the next step.
  - ◆ Yes: You have fewer voltage regulator cards than processor cards. Add another regulator card in the next empty position (see [Locations Model ESCALA PL 850R/PL 1650R/R+](#)). This ends the procedure.
2. Is the reference code 1xxx 8451?
  - ◆ No: Continue with the next step.
  - ◆ Yes: You have too few voltage regulator cards installed. Add another regulator card in the next empty position (see [Locations Model ESCALA PL 850R/PL 1650R/R+](#)). This ends the procedure.
3. Is the reference code 1xxx 1611, 1612, or 1613?
  - ◆ No: Continue with the next step.
  - ◆ Yes: Voltage regulator 1 is the failing item and needs to be replaced (see [Locations Model ESCALA PL 850R/PL 1650R/R+](#) to locate and replace the regulator). This ends the procedure.
4. Is the reference code 1xxx 1621, 1622, or 1623?
  - ◆ No: Continue with the next step.
  - ◆ Yes: Voltage regulator 2 is the failing item and needs to be replaced (see [Locations Model ESCALA PL 850R/PL 1650R/R+](#) to locate and replace the regulator). This ends the

procedure.

5. Is the reference code 1xxx 1631, 1632, or 1633?
    - ◆ No: Continue with the next step.
    - ◆ Yes: Voltage regulator 3 is the failing item and needs to be replaced (see [Locations](#) [Model ESCALA PL 850R/PL 1650R/R+](#) to locate and replace the regulator). This ends the procedure.
  6. Is the reference code 1xxx 2602?
    - ◆ Yes: Continue with the next step.
    - ◆ No: Return to [Start of call procedure](#). This ends the procedure.
  7. Perform the following:
    - a. Remove one of the voltage regulator cards that you have not already removed in this procedure and replace it with a new one (see [Locations](#) [Model ESCALA PL 850R/PL 1650R/R+](#) to locate and replace the regulator).
    - b. Power on the system (see [Powering on and powering off](#)).

Does reference code 1xxx 2602 appear again?

    - ◇ Yes: Continue with the next step.
    - ◇ No: The voltage regulator card that you replaced was the failing item. This ends the procedure.
  8. Have you replaced all of the voltage regulator cards?
    - ◆ Yes: Replace the regulator distribution connection backplane (see [Locations](#) [Model ESCALA PL 850R/PL 1650R/R+](#)). This ends the procedure.
    - ◆ No: Reinstall the original regulator card, and then repeat step 7.
- 

## PWR1920

Use this procedure to verify that the lights on the server control panel and the display panel on all attached I/O expansion units are operating correctly.

Please see [Power isolation procedures](#) for important safety information before continuing with this procedure.

1. If the system has logical partitions, perform this procedure from the primary partition's console and the system control panel. To determine if the system has logical partitions, go to [Determining if the system has logical partitions](#) before continuing with this procedure.
2. Select function 04 Lamp Test on the control panel and press Enter.
3. Review the server control panel and the display panels on all attached I/O towers. The lamp test is only active on the I/O towers for 25 seconds after you press Enter. Are all of the following lights on for all attached I/O towers: power-on light, attention light, and all dots for the 32 character display?
  - ◆ No: Exchange the following field replaceable units in the failing unit one at a time (see [Removing and replacing parts](#)):
    - ◇ Control panel (see [CTLPNL](#))
    - ◇ Tower card (see [TWRCARD](#))
    - ◇ Control panel cable

This ends the procedure.
  - ◆ Yes: These control panel lights are working correctly. Continue with the next step.
4. Are any abnormal characters or character patterns (not reference codes or normal display mode) displayed?
  - ◆ No: Return to [Start of call procedure](#).
 

This ends the procedure.
  - ◆ Yes: Exchange the following FRUs in the failing unit one at a time (see [Removing and replacing parts](#)):
    - ◇ Control panel (see [CTLPNL](#))
    - ◇ Tower card (see [TWRCARD](#))
    - ◇ Control panel cable

This ends the procedure.

**Parent topic:** [Power isolation procedures](#)

---

## PWR2402

The server detected an error in the power system.

### **DANGER**When working on or around the system, observe the following precautions:

Electrical voltage and current from power, telephone, and communication cables are hazardous. To avoid a shock hazard:

- Connect power to this unit only with the provided power cord. Do not use the provided power cord for any other product.
- Do not open or service any power supply assembly.
- Do not connect or disconnect any cables or perform installation, maintenance, or reconfiguration of this product during an electrical storm.
- The product might be equipped with multiple power cords. To remove all hazardous voltages, disconnect all power cords.
- Connect all power cords to a properly wired and grounded electrical outlet. Ensure that the outlet supplies proper voltage and phase rotation according to the system rating plate.
- Connect any equipment that will be attached to this product to properly wired outlets.
- When possible, use one hand only to connect or disconnect signal cables.
- Never turn on any equipment when there is evidence of fire, water, or structural damage.
- Disconnect the attached power cords, telecommunications systems, networks, and modems before you open the device covers, unless instructed otherwise in the installation and configuration procedures.
- Connect and disconnect cables as described in the following procedures when installing, moving, or opening covers on this product or attached devices.

To Disconnect:

1. Turn off everything (unless instructed otherwise).
2. Remove the power cords from the outlets.
3. Remove the signal cables from the connectors.
4. Remove all cables from the devices

To Connect:

1. Turn off everything (unless instructed otherwise).
2. Attach all cables to the devices.
3. Attach the signal cables to the connectors.
4. Attach the power cords to the outlets.
5. Turn on the devices.

(D005)

1. Is the SRC 1xxx-8700 or 8701?
  - ◆ **No:** Return to the [Start of call procedure](#). **This ends the procedure.**
  - ◆ **Yes:** Continue with the next step.
2. In this step you will be measuring voltages on one of the bulk power assemblies (BPAs). If the SRC is 1xxx8700, then you should measure the voltage on BPA-A (front). If the SRC is 1xxx8701, then you should measure the voltage on BPA-B (rear).

Using the labeled test points on the face of the BPA, measure the voltages between the following:

- ◆ phase A and phase B
- ◆ phase B and phase C
- ◆ phase C and phase A

Are all of the meter readings greater than 180 V ac?

- ◆ **Yes:** Go to step 4.
- ◆ **No:** Inform the customer that power voltage at the input to the BPA could be missing or too low and needs to be checked. Continue with the next step once the check has been performed.

3. Does the check confirm that the customer's voltage levels missing or too low?
  - ◆ **Yes:** The customer must correct the voltage levels. **This ends the procedure.**
  - ◆ **No:** Replace the power cord (see [Cables](#) for the proper part number). **This ends the procedure.**
4. Exchange the following FRUs, one at a time, until the problem is resolved. Go to [Locations model 5/75](#) or [Locations model ESCALA PL 3250R and ESCALA PL 6450R](#) to locate and replace the part.
  - a. Bulk power regulator (BPR) 1
  - b. BPR 2
  - c. BPR 3
  - d. Bulk power controller (BPC)
  - e. Bulk power assembly (BPA)

**This ends the procedure.**

Parent topic: [Power isolation procedures](#)

---

## Router isolation procedures

These procedures serve as a guide to the correct isolation procedures from the reference code tables.

### **DANGER**When working on or around the system, observe the following precautions:

Electrical voltage and current from power, telephone, and communication cables are hazardous. To avoid a shock hazard:

- Connect power to this unit only with the provided power cord. Do not use the provided power cord for any other product.
- Do not open or service any power supply assembly.
- Do not connect or disconnect any cables or perform installation, maintenance, or reconfiguration of this product during an electrical storm.
- The product might be equipped with multiple power cords. To remove all hazardous voltages, disconnect all power cords.
- Connect all power cords to a properly wired and grounded electrical outlet. Ensure that the outlet supplies proper voltage and phase rotation according to the system rating plate.
- Connect any equipment that will be attached to this product to properly wired outlets.
- When possible, use one hand only to connect or disconnect signal cables.
- Never turn on any equipment when there is evidence of fire, water, or structural damage.
- Disconnect the attached power cords, telecommunications systems, networks, and modems before you open the device covers, unless instructed otherwise in the installation and configuration procedures.
- Connect and disconnect cables as described in the following procedures when installing, moving, or opening covers on this product or attached devices.
 

To Disconnect:

  1. Turn off everything (unless instructed otherwise).
  2. Remove the power cords from the outlets.
  3. Remove the signal cables from the connectors.
  4. Remove all cables from the devices

To Connect:

1. Turn off everything (unless instructed otherwise).
2. Attach all cables to the devices.
3. Attach the signal cables to the connectors.
4. Attach the power cords to the outlets.
5. Turn on the devices.

(D005)

Perform these procedures only when directed to do so from another procedure.

- **RTRIP02**  
Gives a link to a topic that might assist you when diagnosing workstation IOP detected errors.



- **RTRIP03**  
Gives links to topics to assist you when diagnosing workstation IOP detected errors.
- **RTRIP04**  
Use the FRU list in the service action log if it is available. If it is not available, examine word 5 of the reference code.
- **RTRIP05**  
Use the attached procedure when this reference code occurs for a HSL/RIO loop resource, when an I/O expansion unit on the loop is powered off for a concurrent maintenance action.
- **RTRIP06**  
Use the attached procedure when this reference code occurs in a service action code (SAL).
- **RTRIP07**  
Gives a link to assist you when diagnosing a keyboard error.
- **RTRIP08**  
Gives a link to assist when the Licensed Internal Code detected an IOP programming problem.

**Parent topic:** [Isolation procedures](#)

---

## RTRIP02

Gives a link to a topic that might assist you when diagnosing workstation IOP detected errors.

Perform [TWSIP01](#).

**Parent topic:** [Router isolation procedures](#)

---

## RTRIP03

Gives links to topics to assist you when diagnosing workstation IOP detected errors.

If you have a twinaxial terminal for the console, perform [TWSIP01](#). Otherwise, perform [WSAIP01](#).

**Parent topic:** [Router isolation procedures](#)

---

## RTRIP04

Use the FRU list in the service action log if it is available. If it is not available, examine word 5 of the reference code.

Is word 5 of the reference code zero (0000 0000)?

- Yes: Perform [SIIOADP](#).
- No: Perform [PIOCARD](#).

This ends the procedure.

**Parent topic:** [Router isolation procedures](#)

---

## RTRIP05

Use the attached procedure when this reference code occurs for a HSL/RIO loop resource, when an I/O expansion unit on the loop is powered off for a concurrent maintenance action.

**Note:** This reference code can occur for the HSL/RIO loop resource when an I/O expansion unit on the loop is powered off for a concurrent maintenance action.

**Note:** A fiber optic cleaning kit may be required for optical HSL connections.

1. Multiple B600 6982 errors may occur due to efforts to retry and recover. If the recovery efforts were successful, there will be a B600 6985 reference code with xxxx 3206 in word 4 logged after all B600 6982 reference codes in the product activity log (PAL). If this is the case, close out all the B600 6982 entries. Then continue with the next step.
2. Is there a B600 6987 reference code in the service action log (SAL) logged at about the same time?
  - ◆ Yes: Close this problem and work the B600 6987.
  - ◆ This ends the procedure.
  - ◆ No: Continue with the next step.
3. Is there a B600 6981 reference code in the SAL logged at approximately the same time?
  - ◆ Yes: Go to step 8.
  - ◆ No: Continue with the next step.
4. Perform [RIOIP06](#) to determine if any other systems are connected to this loop and then return here.

**Note:** The loop number can be found in the SAL in the description for the HSL\_LNK FRU.

Are there other systems connect to this loop?

- ◆ Yes: Continue with the next step.
  - ◆ No: Go to step 8.
5. Check for HSL failures in the SALs on the other systems before replacing parts. HSL failures are indicated by SAL entries with HSL I/O bridge and Network Interface Controller (NIC) resources. Ignore B600 6982 and B600 6984 entries.

Are there HSL failures on other systems?

- ◆ Yes: Continue with the next step.
  - ◆ No: Go to step 8.
6. Repair the problems on the other systems and return to this step. After making repairs on the other systems check the PAL of this system. Is there a B600 6985, along with this loop's resource name, that was logged after the repairs you made on the other systems?
    - ◆ Yes: Continue with the next step.
    - ◆ No: Go to step 8.
  7. For the B600 6985 reference code you found, use symbolic FRU [SIRSTAT](#) to determine if the loop is now complete.

Is the loop complete?

- ◆ Yes: The problem has been resolved.
  - ◆ This ends the procedure.
  - ◆ No: Go to step 8.
8. The FRU list displayed in the SAL may be different from the failing item list given here. Use the SAL's FRU list when it is available.

Does this reference code appear in the SAL with the symbolic FRU HSL\_LNK listed as a FRU?

- ◆ Yes: Perform [RIOIP01](#).
- ◆ This ends the procedure.
- ◆ No: Exchange the FRUs listed in the SAL according to their part action codes.
- ◆ This ends the procedure.

**Parent topic:** [Router isolation procedures](#)

---

## RTRIP06

Use the attached procedure when this reference code occurs in a service action code (SAL).

**Note:** A fiber optic cleaning kit may be required for optical HSL connections.

1. Is the reference code in the service action log (SAL)?
  - ◆ Yes: Continue with the next step.
  - ◆ No: The reference code is informational. Use symbolic FRU [SIRSTAT](#) to determine what the reference code means.

This ends the procedure.

2. This error can appear in the SAL if a tower or another system in the loop did not complete powering on before Licensed Internal Code (LIC) checked this loop for errors. Search the product activity log (PAL) for all B600 6985 reference codes logged for this loop and use symbolic FRU [SIRSTAT](#) to determine if this error requires service.

Is further service required?

- ◆ Yes: Continue with the next step.
  - ◆ No: This ends the procedure.
3. There may be multiple B600 6985 reference codes, with xxxx 3205 in word 4, for the same loop resource in the SAL. This is caused by attempts to retry and recover. If there is a B600 6985 reference code with xxxx 3206 or xxxx 3208 in word 4 after the above B600 6985 entries in the PAL, then the recovery efforts were successful. If this is the case, close all the B600 6985 entries for that loop resource in the SAL. Then continue with the next step.
  4. Is there a B600 6981 reference code in the SAL?
    - ◆ Yes: Close that problem and go to step [9](#).
    - ◆ No: Continue with the next step.
  5. Perform [RIOIP06](#) to determine if any other systems are connected to this loop and then return here.

**Note:** The loop number can be found in the SAL in the description for the HSL\_LNK FRU.

Are there other systems connected to this loop?

- ◆ Yes: Continue with the next step.
  - ◆ No: Go to step [9](#).
6. Check for HSL failures in the SALs on the other systems before replacing parts. HSL failures are indicated by SAL entries with HSL I/O bridge and Network Interface Controller (NIC) resources. Ignore B600 6982 and B600 6984 entries.

Are there HSL failures on other systems?

- ◆ Yes: Continue with the next step.
  - ◆ No: Go to step [9](#).
7. Repair the problems on the other systems and return to this step. After making repairs on the other systems check the PAL of this system. Is there a B600 6985 reference code that was logged after the repairs you made on the other systems?
    - ◆ Yes: Continue with the next step.
    - ◆ No: Go to step [9](#).
  8. For the B600 6985 log you found, use symbolic FRU [SIRSTAT](#) to determine if the loop is now complete.

Is the loop complete?

- ◆ Yes: The problem has been resolved.

This ends the procedure.

- ◆ No: Go to step 9.

9. The FRU list displayed in the SAL may be different from the failing item list given here. Use the SAL's FRU list when it is available.

Does this reference code appear in the SAL with the symbolic FRU HSL\_LNK listed as a FRU?

- ◆ Yes: Perform [RIOIP01](#).

This ends the procedure.

- ◆ No: Exchange the FRUs listed in the SAL according to their part action codes.

This ends the procedure.

**Parent topic:** [Router isolation procedures](#)

---

## RTRIP07

Gives a link to assist you when diagnosing a keyboard error.

Perform [WSAIP01](#).

**Parent topic:** [Router isolation procedures](#)

---

## RTRIP08

Gives a link to assist when the Licensed Internal Code detected an IOP programming problem.

Perform a system IPL. Is the IPL successful?

- Yes: Perform [LICIP01](#) to determine the cause of the problem. This ends the procedure.
- No: Perform the action described in the new reference code. This ends the procedure.

**Parent topic:** [Router isolation procedures](#)

---

## Service processor isolation procedures

These procedures help you to isolate problems with the service processor.

### **DANGER**When working on or around the system, observe the following precautions:

Electrical voltage and current from power, telephone, and communication cables are hazardous. To avoid a shock hazard:

- Connect power to this unit only with the provided power cord. Do not use the provided power cord for any other product.
- Do not open or service any power supply assembly.
- Do not connect or disconnect any cables or perform installation, maintenance, or reconfiguration of this product during an electrical storm.
- The product might be equipped with multiple power cords. To remove all hazardous voltages, disconnect all power cords.
- Connect all power cords to a properly wired and grounded electrical outlet. Ensure that the outlet supplies proper voltage and phase rotation according to the system rating plate.
- Connect any equipment that will be attached to this product to properly wired outlets.
- When possible, use one hand only to connect or disconnect signal cables.
- Never turn on any equipment when there is evidence of fire, water, or structural damage.
- Disconnect the attached power cords, telecommunications systems, networks, and modems before you open the device covers, unless instructed otherwise in the installation and configuration

procedures.

- Connect and disconnect cables as described in the following procedures when installing, moving, or opening covers on this product or attached devices.

To Disconnect:

1. Turn off everything (unless instructed otherwise).
2. Remove the power cords from the outlets.
3. Remove the signal cables from the connectors.
4. Remove all cables from the devices

To Connect:

1. Turn off everything (unless instructed otherwise).
2. Attach all cables to the devices.
3. Attach the signal cables to the connectors.
4. Attach the power cords to the outlets.
5. Turn on the devices.

(D005)

- **FSPSP01**  
A part vital to system function has been deconfigured.
- **FSPSP02**  
This procedure is for boot failures that terminate very early in the boot process.
- **FSPSP03**  
A system operator or user error has occurred.
- **FSPSP04**  
A problem has been detected in the service processor firmware.
- **FSPSP05**  
The service processor has detected a problem in the platform firmware.
- **FSPSP06**  
The service processor reported a suspected intermittent problem.
- **FSPSP07**  
The time of day has been reset to the default value.
- **FSPSP08**  
A problem has been detected with a system processor, but it cannot be isolated to a specific processor.
- **FSPSP09**  
A problem has been detected with a memory DIMM, but it cannot be isolated to a specific memory DIMM.
- **FSPSP10**  
The part indicated in the FRU callout that follows this procedure is invalid or missing for this system's configuration.
- **FSPSP11**  
The service processor has detected an error on the RIO/HSL port in the system unit.
- **FSPSP12**  
The DIMM FRU that was called out failed to correct the memory error.
- **FSPSP16**  
Save any error log and dump data and contact your next level of support for assistance.
- **FSPSP17**  
A system uncorrectable error has occurred.
- **FSPSP18**  
A problem has been detected in the platform LIC.
- **FSPSP19**  
The system processor's module interposers have a limit on the number of times modules can be plugged into them.
- **FSPSP20**  
A failing item has been detected by a hardware procedure.
- **FSPSP21**  
The system has detected that all I/O hubs are missing from the system configuration.
- **FSPSP22**  
The system has detected that a processor chip is missing from the system configuration because JTAG lines are not working.
- **FSPSP23**  
The system needs to perform a service processor dump.
- **FSPSP24**  
The system is running degraded. Array bit steering may be able to correct this problem without replacing hardware.

- **FSPSP25**  
The server has detected an over temperature thermal fault.
- **FSPSP26**  
The system has detected a problem with the system backplane.
- **FSPSP27**  
An attention line has been detected as having a problem.
- **FSPSP28**  
The resource ID (RID) of the FRU could not be found in the Vital Product Data (VPD) table.
- **FSPSP29**  
The system has detected that all I/O bridges are missing from the system configuration.
- **FSPSP30**  
A problem has been encountered accessing the VPD card or the data found on the VPD card has been corrupted.
- **FSPSP31**  
The service processor has detected that one or more of the required fields in the system VPD has not been initialized.
- **FSPSP32**  
A problem with the enclosure has been found.
- **FSPSP33**  
A problem has been detected in the connection with the HMC.
- **FSPSP34**  
The memory cards are plugged in an invalid configuration and cannot be used by the system.
- **FSPSP35**  
The system has detected a problem with a memory controller.
- **FSPSP36**  
One or both of the SMP cables connecting the system processors on this system are incorrectly plugged, broken, or not the correct type of cable for this system configuration.
- **FSPSP37**  
A timeout has occurred while waiting for the system processor to access main storage.
- **FSPSP38**  
The system has detected an error within the JTAG path.
- **FSPSP39**  
This procedure will isolate a DIMM failure after the DIMM FRU failed to correct the problem.
- **FSPSP40**  
This procedure is a warning due to an invalid login attempt to the service processor.
- **FSPSP41**  
This procedure will help you isolate a problem that occurred when trying to access a chip on the I2C bus.
- **FSPSP42**  
An error communicating between two system processors was detected.
- **FSPSP43**  
Use this procedure when you are performing a cold service processor replacement and the system uses static IP addressing for Advanced System Management Interface (ASMI) and Hardware Management Console (HMC) network connections.
- **FSPSP44**  
A problem occurred while trying to read from or write to a smartchip FRU.
- **FSPSPC1**  
If the system hangs after the code that sent you to this procedure appears in the control panel, perform these steps to reset the service processor.
- **FSPSPD1**  
If the system hangs after the code that sent you to this procedure appears in the control panel, perform these steps to reset the service processor.

Parent topic: [Isolation procedures](#)

---

## FSPSP01

A part vital to system function has been deconfigured.

Perform the following steps:

1. Is word 6 (the 8 leftmost characters of function 13) of the reference code 0000F234?
  - ◆ No: Go to step 5.
  - ◆ Yes: The system has detected a deconfigured memory controller that is required for the system to function, or it has detected that there is not enough memory or that the memory is plugged incorrectly. Continue with the next step.
2. Perform the following steps:
  - a. Reseat all of the memory DIMMs. Refer to symbolic FRU [MEMDIMM](#), but do not replace any memory DIMMs at this time.
  - b. [Perform a slow boot](#).
 Does the problem persist?
  - ◆ Yes: Continue with the next step.
  - ◆ No: Go to [Verifying the repair](#). This ends the procedure.
3. Perform the following for each of the memory DIMMs:
  - a. Replace the memory DIMM using symbolic FRU [MEMDIMM](#).
  - b. [Perform a slow boot](#) between each replacement.
  - c. Does the problem persist?
    - ◇ Yes: Repeat this step and replace the next memory DIMM. If you have replaced all of the memory DIMMs, then continue with the next step.
    - ◇ No: Go to [Verifying the repair](#). This ends the procedure.
4. Perform the following for each of the memory controllers until the problem is resolved:
  - a. Replace the memory controller using symbolic FRU [MEMCTLR](#).
  - b. [Perform a slow boot](#) between each replacement.
  - c. Go to [Verifying the repair](#). This ends the procedure.
5. Is word 6 of the reference code 0000F237?
  - ◆ No: Continue with the next step.
  - ◆ Yes: The system has detected a problem with a clock card. Perform the following for each of the clock cards until the problem is resolved:
    - a. Replace the clock card using symbolic FRU [CLCKMOD](#).
    - b. [Perform a slow boot](#) between each replacement.
    - c. Go to [Verifying the repair](#). This ends the procedure.
6. Is word 6 of the reference code 0000F230?
  - ◆ No: Continue with the next step.
  - ◆ Yes: The system has detected that all of the planars are deconfigured. Perform the following steps:
    - a. Review the system error logs for errors that called out planars. This will indicate which planars have problems and need to be replaced.
    - b. Go to symbolic FRU [NODEPL](#) to replace the appropriate planar or planars.
    - c. [Perform a slow boot](#) after replacing the appropriate planar(s).
    - d. Go to [Verifying the repair](#). This ends the procedure.
7. Is word 6 of the reference code 0000F231?
  - ◆ No: Continue with the next step.
  - ◆ Yes: The system has detected that all of the I/O bridges are deconfigured. Perform the following:
    - a. Review the system error logs for errors that called out I/O bridges. This will indicate which I/O bridges have problems and need to be replaced.
    - b. Replace the appropriate I/O bridges using symbolic FRU [IOBRDG](#).
    - c. [Perform a slow boot](#).
    - d. Go to [Verifying the repair](#). This ends the procedure.
8. Is word 6 of the reference code 0000F236?
  - ◆ No: Return to [Start of call procedure](#). This ends the procedure.
  - ◆ Yes: The system has detected that all of the I/O hubs are deconfigured. Perform the following:
    - a. Review the system error logs for errors that called out I/O hubs. This will indicate which I/O hubs have problems and need to be replaced.
    - b. Replace the appropriate I/O hubs using symbolic FRU [IO\\_HUB](#).
    - c. [Perform a slow boot](#).
    - d. Go to [Verifying the repair](#). This ends the procedure.

Parent topic: [Service processor isolation procedures](#)

---

## FSPSP02

This procedure is for boot failures that terminate very early in the boot process.

This error path is indicated when the SRC data words are scrolling automatically through control panel functions 11, 12, and 13, and the control panel interface buttons are not responsive.

Perform the following:

1. Push the white power button to reset the system and bring it up on the other side of platform LIC.

**Note:** The white power button will only reset the system and attempt to reach standby.

2. Did an SRC occur after bringing the system up on the other side?
  - ◆ No: Update the code on the other side by performing symbolic FRU [LICCODE](#). This ends the procedure.
  - ◆ Yes: Continue with the next step.
3. Is the SRC the same SRC that brought you to this procedure?
  - ◆ No: Return to [Start of call procedure](#) to service this new SRC. This ends the procedure.
  - ◆ Yes: Perform the following:
    - a. Replace the service processor using symbolic FRU [SVCPROC](#).
    - b. If the problem persists, replace the system backplane using symbolic FRU [SYSBKPL](#).This ends the procedure.

**Parent topic:** [Service processor isolation procedures](#)

---

## FSPSP03

A system operator or user error has occurred.

Refer to the documentation for the function you were attempting to perform.

**Parent topic:** [Service processor isolation procedures](#)

---

## FSPSP04

A problem has been detected in the service processor firmware.

Perform [LICCODE](#).

**Parent topic:** [Service processor isolation procedures](#)

---

## FSPSP05

The service processor has detected a problem in the platform firmware.

Perform symbolic FRU [LICCODE](#).



Parent topic: [Service processor isolation procedures](#)

---

## FSPSP06

The service processor reported a suspected intermittent problem.

Contact your next level of support.

Parent topic: [Service processor isolation procedures](#)

---

## FSPSP07

The time of day has been reset to the default value.

1. To set the time of day, refer to [Changing the time of day](#).
2. If the problem persists, replace the TOD battery. See symbolic FRU [TOD\\_BAT](#).
3. After replacing the battery, [perform a slow boot](#). This ends the procedure.

Parent topic: [Service processor isolation procedures](#)

---

## FSPSP08

A problem has been detected with a system processor, but it cannot be isolated to a specific processor.

Perform the following steps:

1. Replace system processors one at a time until the problem is resolved. See symbolic FRU [ANYPROC](#) for details.
2. [Perform a slow boot](#) after replacing each processor. This ends the procedure.

Parent topic: [Service processor isolation procedures](#)

---

## FSPSP09

A problem has been detected with a memory DIMM, but it cannot be isolated to a specific memory DIMM.

1. Replace all memory DIMMs one at a time until the problem is resolved. See symbolic FRU [MEMDIMM](#) for instructions.
2. [Perform a slow boot](#) after replacing each memory DIMM. This ends the procedure.

Parent topic: [Service processor isolation procedures](#)

---

## FSPSP10

The part indicated in the FRU callout that follows this procedure is invalid or missing for this system's configuration.

Perform the following to correct the problem:

1. Does word 8 (the 8 leftmost characters in the 2nd line of function 13) of the reference code end with 02 or 04?
  - ◆ No: Go to step 3.
  - ◆ Yes: Continue with the next step.
2. The FRU that is called out after this procedure is either missing or invalid. Is that FRU installed and connected or plugged in properly?
  - ◆ Yes: The installed FRU is invalid. Remove that FRU. Then contact your next level of support to determine the correct FRU. This ends the procedure.
  - ◆ No: The FRU is missing. If the FRU is present but not connected, reconnect it and perform a slow boot (see [Performing a slow boot](#)). Otherwise, contact your next level of support to determine the missing FRU. This ends the procedure.
3. Does word 8 end with 01 or 05?
  - ◆ No: Return to the [Start of call procedure](#). This ends the procedure.
  - ◆ Yes: The FRU that is called out after this procedure has the same serial number as another FRU in the system. Remove all but one of the FRUs that are called out after this procedure and then perform a slow boot (see [Performing a slow boot](#)). This ends the procedure.

**Parent topic:** [Service processor isolation procedures](#)

---

## FSPSP11

The service processor has detected an error on the RIO/HSL port in the system unit.

1. Perform symbolic FRU [LICCODE](#).
2. If the problem persists, replace the I/O hub using symbolic FRU [IO\\_HUB](#). This ends the procedure.

**Parent topic:** [Service processor isolation procedures](#)

---

## FSPSP12

The DIMM FRU that was called out failed to correct the memory error.

Perform the following:

1. Power off the system (see [Powering on and powering off](#)).
2. Replace the board that the DIMM is plugged into using symbolic FRU [MEMBRD](#).
3. [Perform a slow boot](#).
4. Are you working on a model 5/90?
  - ◆ No: This ends the procedure.
  - ◆ Yes: Continue with the next step.
5. Does the problem persist?
  - ◆ No: This ends the procedure.
  - ◆ Yes: Continue with the next step.
6. Power off the system (see [Powering on and powering off](#)).
7. Replace the MCM related to the DIMM FRU using symbolic FRU [MEMCTLR](#).
8. [Perform a slow boot](#).

This ends the procedure.

**Parent topic:** [Service processor isolation procedures](#)

---

## FSPSP16

Save any error log and dump data and contact your next level of support for assistance.

**Parent topic:** [Service processor isolation procedures](#)

---

## FSPSP17

A system uncorrectable error has occurred.

1. Look for other serviceable events and use the call outs listed with them to correct the problem.
2. If you need to, you can run the system in a degraded mode until you can perform the service actions. To run the system in a degraded mode, do the following:
  - a. Power off the system (see [Powering on and powering off](#)).
  - b. Power on the system (see [Powering on and powering off](#)) to allow the memory diagnostics to clean up the memory. Guard out any defective parts.

**This ends the procedure.**

**Parent topic:** [Service processor isolation procedures](#)

---

## FSPSP18

A problem has been detected in the platform LIC.

Perform symbolic FRU [LICCODE](#).

**Parent topic:** [Service processor isolation procedures](#)

---

## FSPSP19

The system processor's module interposers have a limit on the number of times modules can be plugged into them.

This procedure is usually called out due to a maintenance action dealing with an MCM and indicates that the plug count has been exceeded or is incorrect.

**Note:** Refer to [Changing the interposer plug count](#) for more information when performing this procedure.

1. Log on to the ASMI (see [Accessing the Advanced System Management Interface](#)).
2. Select System Configuration > Interposer Plug Count.
3. Find the target location code for the corresponding interposer.
4. Increment the interposer count by one.
5. Does the plug count exceed 10?
  - ◆ Yes: Perform the following:
    - a. Power off the system (see [Powering on and powering off](#)).
    - b. Replace the system processor for the interposer card that has exceeded 10 using symbolic FRU [ANYPROC](#).
    - c. Reset the plug count to one (1) with the ASMI.

- d. [Perform a slow boot](#) and handle any new serviceable events as new problems. This ends the procedure.
- ◆ No: [Perform a slow boot](#) and handle any new serviceable events as new problems. This ends the procedure.

Parent topic: [Service processor isolation procedures](#)

---

## FSPSP20

A failing item has been detected by a hardware procedure.

[Perform a slow boot](#) to run full hardware diagnostics. If a new SRC occurs, go to [Reference codes](#). If an incomplete occurs, go to [Accessing the ASMI](#) menus to power off, check for garded off components and do a slow boot.

Parent topic: [Service processor isolation procedures](#)

---

## FSPSP21

The system has detected that all I/O hubs are missing from the system configuration.

1. Power off the system (see [Powering on and powering off](#)).
2. Replace the service processor using symbolic FRU [SVCPROC](#).
3. [Perform a slow boot](#).
4. Are you working on a model ESCALA PL 250R-L, ESCALA PL 450T/R, ?
  - ◆ Yes: This ends the procedure.
  - ◆ No: Continue with the next step.
5. Does the problem persist?
  - ◆ Yes: Continue with the next step.
  - ◆ No: This ends the procedure.
6. Power off the system (see [Powering on and powering off](#)).
7. Replace the system backplane using symbolic FRU [SYSBKPL](#).
8. [Perform a slow boot](#).
9. Choose from the following:
  - ◆ If you are working on a model ESCALA PL 250T/R or ESCALA PL 850R/PL 1650R/R+ 4-way, this ends the procedure.
  - ◆ If you are working on a model ESCALA PL 850R/PL 1650R/R+ 8-way through 16-way, continue with the next step.
  - ◆ If you are working on a model ESCALA PL 3250R or ESCALA PL 6450R, go to step 11.
10. Does the problem persist?
  - ◆ No: This ends the procedure.
  - ◆ Yes: Perform the following:
    - a. Power off the system (see [Powering on and powering off](#)).
    - b. Replace each of the node planars one at a time using symbolic FRU [NODEPL](#), [performing a slow boot](#) between each exchange, until the problem is resolved. This ends the procedure.
11. Does the problem persist?
  - ◆ No: This ends the procedure.
  - ◆ Yes: Continue with the next step.
12. Perform the following for each of the node planars:
  - a. Power off the system (see [Powering on and powering off](#)).
  - b. Replace one of the node planars using symbolic FRU [NODEPL](#).
  - c. [Perform a slow boot](#).
  - d. Does the problem persist?
    - ◇ No: This ends the procedure.
    - ◇ Yes: Continue with the next step.
13. Have you replaced each node planar?
  - ◆ No: Repeat step 12 and replace the next node planar.
  - ◆ Yes: Replace each of the I/O hubs one at a time using symbolic FRU [IO\\_HUB](#), [performing a slow boot](#) between each exchange, until the problem is resolved. This ends the procedure.

Parent topic: [Service processor isolation procedures](#)

---

## FSPSP22

The system has detected that a processor chip is missing from the system configuration because JTAG lines are not working.

1. Power off the system (see [Powering on and powering off](#)).
2. Replace the service processor using symbolic FRU [SVCPROC](#).
3. [Perform a slow boot](#).
4. Does the problem persist?
  - ◆ Yes: Continue with the next step.
  - ◆ No: This ends the procedure.
5. Perform the following for each system processor until the problem is resolved:
  - a. Power off the system (see [Powering on and powering off](#)).
  - b. Replace one of the system processors using symbolic FRU [ANYPROC](#).
  - c. [Perform a slow boot](#) after replacing each processor.

This ends the procedure.

**Parent topic:** [Service processor isolation procedures](#)

---

## FSPSP23

The system needs to perform a service processor dump.

1. Perform a service processor dump (see [Performing a platform system or service processor dump](#)).
2. Once the dump is complete, attempt to re-IPL the system.
3. Save the service processor dump to storage (see [Copying a dump](#)).
4. Contact your next level of support. This ends the procedure.

**Parent topic:** [Service processor isolation procedures](#)

---

## FSPSP24

The system is running degraded. Array bit steering may be able to correct this problem without replacing hardware.

1. Power off the system (see [Powering on and powering off](#)).
2. [Perform a slow boot](#). This ends the procedure.
3. If the problem persists, replace the FRU that is called out after this procedure. This ends the procedure.

**Parent topic:** [Service processor isolation procedures](#)

---

## FSPSP25

The server has detected an over temperature thermal fault.

1. Before replacing any server hardware FRU callouts, look for thermal problems related to fans, power supplies, etc. Perform all service actions for the thermal problem SRCs first before continuing with any other callouts in the current SRC. Thermal problems are associated with 1100 xxxx SRCs, where xxxx may be any of the following:
  - ◆ 1514
  - ◆ 1524
  - ◆ 7201
  - ◆ 7203
  - ◆ 7205
  - ◆ 7610
  - ◆ 7611
  - ◆ 7620
  - ◆ 7621
  - ◆ 7630
  - ◆ 7631

2. If no thermal related SRCs or problems can be found, replace the server hardware FRU called out in the current SRC. This ends the procedure.

**Parent topic:** [Service processor isolation procedures](#)

---

## FSPSP26

The system has detected a problem with the system backplane.

1. Power off the system (see [Powering on and powering off](#)).
2. Replace the system backplane using symbolic FRU [SYSBKPL](#).
3. [Perform a slow boot](#). This ends the procedure.

**Parent topic:** [Service processor isolation procedures](#)

---

## FSPSP27

An attention line has been detected as having a problem.

1. Power off the system (see [Powering on and powering off](#)).
2. Are you working on a model 5/70?
  - ◆ No: Go to step 4.
  - ◆ Yes: Continue with the next step.
3. Perform the following:
  - a. Check the flex cables and replace them if necessary.
  - b. [Perform a slow boot](#).
  - c. Does the problem persist?
    - ◇ No: This ends the procedure.
    - ◇ Yes: Continue with the next step.
4. Replace the service processor using symbolic FRU [SVCPROC](#).
5. [Perform a slow boot](#).
6. Are you working on a model ESCALA PL 250R-VL or ESCALA PL 450R-XS, ESCALA PL 250R-L ?
  - ◆ Yes: This ends the procedure.
  - ◆ No: Continue with the next step.
7. Does the problem persist?
  - ◆ No: This ends the procedure.
  - ◆ Yes: Choose from the following:
    - ◇ If you are working on a model ESCALA PL 450T/R, , go to step 11.
    - ◇ If you are working on any other model, continue with the next step.
8. Perform the following:
  - a. Power off the system (see [Powering on and powering off](#)).
  - b. Replace the system backplane using symbolic FRU [SYSBKPL](#).
  - c. [Perform a slow boot](#).
9. Are you working on a model 5/20?
  - ◆ Yes: This ends the procedure.
  - ◆ No: Continue with the next step.
10. Does the problem persist?
  - ◆ No: This ends the procedure.
  - ◆ Yes: Continue with the next step.
11. Choose from the following:
  - ◆ If you are working on a model ESCALA PL 450T/R, or ESCALA PL 850R/PL 1650R/R+ (4-way), perform the following:
    - a. Power off the system (see [Powering on and powering off](#)).
    - b. Replace all system processors using symbolic FRU [ANYPROC](#).
    - c. [Perform a slow boot](#). This ends the procedure.
  - ◆ If you are working on a model ESCALA PL 850R/PL 1650R/R+ (8-way through 16 way), ESCALA PL 3250R, or ESCALA PL 6450R, perform the following:
    - a. Power off the system (see [Powering on and powering off](#)).
    - b. Replace the node planer that is indicated in word 6 (the 8 leftmost characters of function 13) using symbolic FRU [NODEPL](#)
    - c. [Perform a slow boot](#). This ends the procedure.

**Parent topic:** [Service processor isolation procedures](#)

---

## FSPSP28

The resource ID (RID) of the FRU could not be found in the Vital Product Data (VPD) table.

1. Find another callout that reads "FSPxxxx" where xxxx is a 4 digit hex number that represents the RID. Record the RID.
2. Use ASMI to find the RID in the VPD table (see [Viewing vital product data](#)).
3. Replace the RID that is called out.
4. [Perform a slow boot](#) to ensure full hardware diagnostics. This ends the procedure.

**Parent topic:** [Service processor isolation procedures](#)

---

## FSPSP29

The system has detected that all I/O bridges are missing from the system configuration.

1. Power off the system (see [Powering on and powering off](#)).
2. Replace the service processor using symbolic FRU [SVCPROC](#).
3. [Perform a slow boot](#).
4. Are you working on a model ESCALA PL 250R-L, ESCALA PL 450T/R, ?
  - ◆ Yes: This ends the procedure.
  - ◆ No: Continue with the next step.
5. Does the problem persist?
  - ◆ No: This ends the procedure.
  - ◆ Yes: Continue with the next step.
6. Power off the system (see [Powering on and powering off](#)).
7. Replace the system backplane using symbolic FRU [SYSBKPL](#).
8. [Perform a slow boot](#).
9. Choose from the following:
  - ◆ If you are working on a model ESCALA PL 250T/R or ESCALA PL 850R/PL 1650R/R+ (4-way), this ends the procedure.
  - ◆ If you are working on a model ESCALA PL 850R/PL 1650R/R+ (8-way through 16-way), ESCALA PL 3250R, or ESCALA PL 6450R, continue with the next step.
10. Does the problem persist?
  - ◆ No: This ends the procedure.
  - ◆ Yes: Perform the following:
    - a. Power off the system (see [Powering on and powering off](#)).
    - b. Replace each of the node planars one at a time using symbolic FRU [NODEPL](#), [performing a slow boot](#) between each exchange, until the problem is resolved. This ends the procedure.

**Parent topic:** [Service processor isolation procedures](#)

---

## FSPSP30

A problem has been encountered accessing the VPD card or the data found on the VPD card has been corrupted.

This error occurred before VPD collection was completed, so no location codes have been created.

Choose the appropriate system model:

- [Instructions for models ESCALA PL 250T/R, ESCALA PL 850R/PL 1650R/R+, ESCALA PL 3250R, and ESCALA PL 6450R](#)
- [Instructions for models ESCALA PL 250R-L, ESCALA PL 450T/R, 7/20](#)

**Parent topic:** [Service processor isolation procedures](#)

## Instructions for models ESCALA PL 250T/R, ESCALA PL 850R/PL 1650R/R+, ESCALA PL 3250R, and ESCALA PL 6450R

1. Power off the system (see [Powering on and powering off](#)) and remove ac power.
2. Replace the VPD card using symbolic FRU [CAPACTY](#).
3. Perform a slow boot using the ASMI (see [Performing a slow boot](#)).
  - ◆ Yes: Continue with the next step.
  - ◆ No: Go to [Verifying the repair](#). This ends the procedure.
4. Power off the system (see [Powering on and powering off](#)) and remove ac power.
5. Replace the service processor using symbolic FRU [SVCPROC](#).
6. Perform a slow boot using the ASMI (see [Performing a slow boot](#)). Does the error reoccur?
  - ◆ Yes: Choose from the following:
    - ◇ If you are working on a model ESCALA PL 250T/R or ESCALA PL 850R/PL 1650R/R+, continue with the next step.
    - ◇ If you are working on a model ESCALA PL 3250R or ESCALA PL 6450R, contact your next level of support. This ends the procedure.
  - ◆ No: Go to [Verifying the repair](#). This ends the procedure.
7. Power off the system (see [Powering on and powering off](#)).
8. Replace the system backplane using symbolic FRU [SYSBKPL](#).
9. Reinstall the service processor that you replaced in step 5.
10. Perform a slow boot using the ASMI (see [Performing a slow boot](#)).
  - ◆ Yes: Contact your next level of support. This ends the procedure.
  - ◆ No: Go to [Verifying the repair](#). This ends the procedure.

## Instructions for models ESCALA PL 250R-L, ESCALA PL 450T/R, 7/20

1. Power off the system (see [Powering on and powering off](#)) and remove ac power.
2. Replace the VPD card using symbolic FRU [CAPACTY](#).
3. Perform a slow boot using the ASMI (see [Performing a slow boot](#)). Does the error reoccur?
  - ◆ Yes: Continue with the next step.
  - ◆ No: Go to [Verifying the repair](#). This ends the procedure.
4. Power off the system (see [Powering on and powering off](#)) and remove ac power.
5. Replace the system backplane using symbolic FRU [SYSBKPL](#).
6. Perform a slow boot using the ASMI (see [Performing a slow boot](#)). Does the error reoccur?
  - ◆ Yes: Contact your next level of support. This ends the procedure.
  - ◆ No: Go to [Verifying the repair](#). This ends the procedure.

## FSPSP31

The service processor has detected that one or more of the required fields in the system VPD has not been initialized.

1. Log into ASMI with authorized service provider authority (see [Accessing the Advanced System Management Interface](#)).
2. Set the system VPD values (see [Programming vital product data](#)).

**Note:** The service processor will automatically reset when leaving the ASMI after updating the system VPD.

3. Power on the system ([Powering on and powering off](#)). This ends the procedure.

**Parent topic:** [Service processor isolation procedures](#)

## FSPSP32

A problem with the enclosure has been found.

The problem is resulting from one of the following:



- the enclosure VPD cannot be found,
- the enclosure serial number is not programmed, or
- the enclosure feature code is not programmed.

Perform the following:

1. Record the reason code (the last 4 characters of word 11) from the SRC by looking at the operator panel or accessing the error log with the ASMI.
2. Is the reason code B06F?
  - ◆ No: Go to step 6.
  - ◆ Yes: Continue with the next step.
3. Check for and apply any server firmware updates (see [Server firmware fixes](#)). Does the problem persist?
  - ◆ No: This ends the procedure.
  - ◆ Yes: Continue with the next step.
4. Perform the following:
  - a. Replace the service processor using symbolic FRU [SVCPROC](#).
  - b. Perform a slow boot (see [Performing a slow boot](#)).
 Does the problem persist?
  - ◆ No: This ends the procedure.
  - ◆ Yes: Continue with the next step.
5. Perform the following:
  - a. Replace the system backplane using symbolic FRU [SYSBKPL](#).
  - b. Perform a slow boot (see [Performing a slow boot](#)).
 Does the problem persist?
  - ◆ No: This ends the procedure.
  - ◆ Yes: Contact your next level of support. This ends the procedure.
6. Is the reason code B071?
  - ◆ No: Go to step 8.
  - ◆ Yes: Continue with the next step.
7. Perform the following:
  - a. Set the enclosure serial number using the ASMI (see [Setting the system identifiers](#)).
  - b. The service processor will automatically reset when leaving the ASMI after updating the serial number.
  - c. Perform a slow boot (see [Performing a slow boot](#)).
 Does the problem persist?
  - ◆ No: This ends the procedure.
  - ◆ Yes: Contact your next level of support. This ends the procedure.
8. Is the reason code B07D?
  - ◆ No: Contact your next level of support. This ends the procedure.
  - ◆ Yes: Continue with the next step.
9. Perform the following:
  - a. Set the enclosure feature code using the ASMI (see [Setting the system enclosure type](#)).
  - b. The service processor will automatically reset when leaving the ASMI after updating the serial number.
  - c. Perform a slow boot (see [Performing a slow boot](#)).
 Does the problem persist?
  - ◆ No: This ends the procedure.
  - ◆ Yes: Contact your next level of support. This ends the procedure.

**Parent topic:** [Service processor isolation procedures](#)

---

## FSPSP33

A problem has been detected in the connection with the HMC.

1. Ensure that the cable connectors to the network from the HMC, managed system, managed system partitions, and other HMCs are securely connected. If the connections are not secure, plug the cables back into the proper spots and make sure that the connections are good.

2. Check to see if the HMC is working correctly or if the HMC was disconnected incorrectly from the managed system, managed system partitions, and other HMCs. If either has happened, reboot the HMC. For more information, see [Shutting down, rebooting, and logging off the HMC](#).
3. Verify that the network connection between the HMC, managed system, managed system partitions, and other HMCs is working properly. If you have a high performance switch (HPS) network, verify that the network connection to the CSM Management Server is also working. If the connection is not working properly, contact the customer network support to correct the problems.
4. If applicable, service the next FRU.
5. If the problem continues to persist, contact your next level of support. This ends the procedure.

Parent topic: [Service processor isolation procedures](#)

---

## FSPSP34

The memory cards are plugged in an invalid configuration and cannot be used by the system.

1. Is the SRC B1xx F642?
  - ◆ Yes: A memory card is missing from the system. The additional parts in the FRU callout list will include all memory cards in the group with the missing card. To correct the error, visually check the system to determine which of these cards is missing, and add the card (For models ESCALA PL 3250R and 5/95: see [Memory plugging for models ESCALA PL 3250R and ESCALA PL 6450R](#)). This ends the procedure.
  - ◆ No: Continue with the next step.
2. Is the SRC B1xx F643?
  - ◆ Yes: A memory card is a different type than the other memory cards in the same group. The additional parts in the FRU callout list will include all memory cards in the group that contain the error. To correct the error, exchange the memory cards of the incorrect type with those of the desired type. This ends the procedure.
  - ◆ No: Continue with the next step.
3. Is the SRC B1xx F688?
  - ◆ Yes: There are one or more memory cards that are incompatible with the other memory cards plugged into the same board in the system. The additional parts in the FRU callout list will include all memory cards that are incompatible. To correct the error, remove these cards from the system. This ends the procedure.
  - ◆ No: Return to [Start of call procedure](#). This ends the procedure.

Parent topic: [Service processor isolation procedures](#)

---

## FSPSP35

The system has detected a problem with a memory controller.

Perform the following to enable redundant utilization:

1. Power off the system (see [Powering on and powering off](#)).
2. [Perform a slow boot](#). This ends the procedure.

Parent topic: [Service processor isolation procedures](#)

---

## FSPSP36

One or both of the SMP cables connecting the system processors on this system are incorrectly plugged, broken, or not the correct type of cable for this system configuration.

By analyzing the last 4 characters (reason code) of word 11 of the SRC, we can narrow down the reason for the error:

- If the reason code is B08E, then there was a mismatch or parity error in the SMP cables identity on the system processors in the system.
- If the reason code is F23E, then there was a mismatch on the SMP cables plugged into the system and the number of nodes detected in the system.
- If the reason code is FB53, then a system processor had an error that may have been caused by a bad SMP cable.

Perform the following, regardless of the reason code:

1. Re-plug the SMP cables that connect to the system processors.
2. [Perform a slow boot](#).
3. Does the problem persist?
  - ◆ Yes: Continue with the next step.
  - ◆ No: This ends the procedure.
4. Replace the SMP cables.
5. [Perform a slow boot](#).
6. Does the problem persist?
  - ◆ No: This ends the procedure.
  - ◆ Yes: Continue with the next step.
7. Perform the following for each system processor:
  - a. Power off the system (see [Powering on and powering off](#)).
  - b. Remove one of the processors using symbolic FRU [ANYPROC](#).
  - c. [Perform a slow boot](#).
  - d. Does the problem persist?
    - ◇ Yes: Reinstall the processor you removed and then repeat this step, removing the next processor.
    - ◇ No: Replace the processor you just removed, it is the failing item. This ends the procedure.

**Parent topic:** [Service processor isolation procedures](#)

---

## FSPSP37

A timeout has occurred while waiting for the system processor to access main storage.

Choose the procedure for the model you are working on:

- [FSPSP37 instructions for Models ESCALA PL 250R-L, ESCALA PL 250T/R, 7/10](#)
- [FSPSP37 instructions for Models ESCALA PL 250T/R, ESCALA PL 450T/R, and ESCALA PL 850R/PL 1650R/R+ \(4-way\)](#)
- [FSPSP37 instructions for Model ESCALA PL 850R/PL 1650R/R+ \(8-way through 16-way\)](#)
- [FSPSP37 instructions for Model 5/75](#)
- [FSPSP37 instructions for Model ESCALA PL 3250R](#)

**Parent topic:** [Service processor isolation procedures](#)

**FSPSP37 instructions for Models ESCALA PL 250R-L, ESCALA PL 250T/R, 7/10**

1. Power off the system (see [Powering on and powering off](#)).
2. Replace the system backplane using symbolic FRU [SYSBKPL](#).
3. [Perform a slow boot](#). This ends the procedure.

**FSPSP37 instructions for Models ESCALA PL 250T/R, ESCALA PL 450T/R, and ESCALA PL 850R/PL 1650R/R+ (4-way)**

1. Perform the following for each system processor:
  - a. Power off the system (see [Powering on and powering off](#)).
  - b. Replace one of the system processors using symbolic FRU [ANYPROC](#).
  - c. [Perform a slow boot](#).
  - d. Does the problem persist?

- ◇ No: This ends the procedure.
- ◇ Yes: Continue with the next step.
- 2. Have you replaced all of the system processors?
  - ◆ No: Repeat step 4 and replace the next processor.
  - ◆ Yes: Continue with the next step.
- 3. Perform the following:
  - a. Power off the system (see [Powering on and powering off](#)).
  - b. Replace the RIO adapter card using symbolic FRU [SI\\_CARD](#).
  - c. [Perform a slow boot](#).
  - d. Does the problem persist?
    - ◇ No: This ends the procedure.
    - ◇ Yes: Continue with the next step.
- 4. Perform the following:
  - a. Power off the system (see [Powering on and powering off](#)).
  - b. Replace the system or I/O backplane using symbolic FRU [SYSBKPL](#).
  - c. [Perform a slow boot](#). This ends the procedure.

#### FSPSP37 instructions for Model ESCALA PL 850R/PL 1650R/R+ (8-way through 16-way)

1. Power off the system (see [Powering on and powering off](#)).
2. Replace the SMP cables.
3. [Perform a slow boot](#).
4. Does the problem persist?
  - ◆ No: This ends the procedure.
  - ◆ Yes: Continue with the next step.
5. Perform the following for each system processor:
  - a. Power off the system (see [Powering on and powering off](#)).
  - b. Replace one of the system processors using symbolic FRU [ANYPROC](#).
  - c. [Perform a slow boot](#).
  - d. Does the problem persist?
    - ◇ No: This ends the procedure.
    - ◇ Yes: Continue with the next step.
6. Have you replaced all of the system processors?
  - ◆ No: Repeat step 5 and replace the next processor.
  - ◆ Yes: Continue with the next step.
7. Perform the following:
  - a. Power off the system (see [Powering on and powering off](#)).
  - b. Replace the RIO adapter card using symbolic FRU [SI\\_CARD](#).
  - c. [Perform a slow boot](#).
  - d. Does the problem persist?
    - ◇ No: This ends the procedure.
    - ◇ Yes: Continue with the next step.
8. Perform the following:
  - a. Power off the system (see [Powering on and powering off](#)).
  - b. Replace each of the node planars, one at a time, using symbolic FRU [NODEPL](#), [performing a slow boot](#) after replacing each planar, until the problem is resolved. This ends the procedure.

#### FSPSP37 instructions for Model 5/75

1. Power off the system (see [Powering on and powering off](#)).
2. Perform the following for each system processor:
  - a. Power off the system (see [Powering on and powering off](#)).
  - b. Replace one of the system processors using symbolic FRU [ANYPROC](#).
  - c. [Perform a slow boot](#).
  - d. Does the problem persist?
    - ◇ No: This ends the procedure.
    - ◇ Yes: Continue with the next step.
3. Have you replaced all of the system processors?
  - ◆ No: Repeat step 2 and replace the next processor.
  - ◆ Yes: Continue with the next step.
4. Power off the system (see [Powering on and powering off](#)).
5. Replace the system backplane using symbolic FRU [SYSBKPL](#).
6. [Perform a slow boot](#). This ends the procedure.

## FSPSP37 instructions for Model ESCALA PL 3250R

1. Determine which node on the system has the problem by performing the following:
    - a. Power off the system (see [Powering on and powering off](#)).
    - b. Replace one of the nodes.
    - c. [Perform a slow boot](#).
    - d. Does the problem persist?
      - ◇ No: The node you just replaced is causing the problem. Go to step 3.
      - ◇ Yes: Continue with the next step.
  2. Have you tried replacing all of the nodes?
    - ◆ No: Repeat step 1 and replace the next node.
    - ◆ Yes: Replace the system backplane using symbolic FRU [SYSBKPL](#). This ends the procedure.
  3. Determine what part in the failing node is causing the problem by performing the following:
    - a. Power off the system (see [Powering on and powering off](#)).
    - b. Replace the RIO adapter card using symbolic FRU [SI\\_CARD](#).
    - c. Reinstall the failing node.
    - d. [Perform a slow boot](#).
    - e. Does the problem persist?
      - ◇ No: This ends the procedure.
      - ◇ Yes: Continue with the next step.
  4. Perform the following:
    - a. Power off the system (see [Powering on and powering off](#)).
    - b. Replace one of the system processors on the failing node using symbolic FRU [ANYPROC](#).
    - c. [Perform a slow boot](#).
    - d. Does the problem persist?
      - ◇ No: This ends the procedure.
      - ◇ Yes: Continue with the next step.
  5. Have you replaced all of the system processors on the failing node?
    - ◆ No: Repeat step 4 and replace the next processor.
    - ◆ Yes: Perform the following:
      - a. Power off the system (see [Powering on and powering off](#)).
      - b. Replace the failing node backplane using symbolic FRU [NODEPL](#).
      - c. [Perform a slow boot](#). This ends the procedure.
- 

## FSPSP38

The system has detected an error within the JTAG path.

1. Power off the system (see [Powering on and powering off](#)).
2. Are you working on a model ESCALA PL 3250R or 5/95?
  - ◆ Yes: Continue with the next step.
  - ◆ No: Go to step 6.
3. Replace the multiplexer (JMUX) card (location: Un-Pn-C7) for the associated node.
4. [Perform a slow boot](#).
5. Does the problem persist?
  - ◆ Yes: Power off the system (see [Powering on and powering off](#)), continue with the next step.
  - ◆ No: This ends the procedure.
6. Replace the service processor using symbolic FRU [SVCPROC](#).
7. [Perform a slow boot](#).
8. Are you working on a model ESCALA PL 250R-VL or ESCALA PL 450R-XS, ESCALA PL 250R-L, ESCALA PL 450T/R, ?
  - ◆ Yes: This ends the procedure.
  - ◆ No: Continue with the next step.
9. Does the problem persist?
  - ◆ Yes: Power off the system (see [Powering on and powering off](#)), continue with the next step.
  - ◆ No: This ends the procedure.
10. Are you working on a model ESCALA PL 1650R-L+ or ESCALA PL 850R/PL 1650R/R+ with 2 or more processor nodes?
  - ◆ Yes: Continue with the next step.
  - ◆ No: Go to step 14.
11. Replace the service processor flex cable (see [Model ESCALA PL 1650R-L+ or ESCALA PL 850R/PL 1650R/R+ cables](#)).
12. [Perform a slow boot](#).
13. Does the problem persist?

- ◆ Yes: Power off the system (see [Powering on and powering off](#)), continue with the next step.
  - ◆ No: This ends the procedure.
14. Replace the node backplane using symbolic FRU [NODEPL](#).
  15. [Perform a slow boot](#).
  16. Are you working on a model ESCALA PL 250T/R or 5/2A?
    - ◆ Yes: Continue with the next step.
    - ◆ No: This ends the procedure.
  17. Replace the system backplane using symbolic FRU [SYSBKPL](#).
  18. [Perform a slow boot](#).
  19. Does the problem persist?
    - ◆ Yes: Contact your next level of support. This ends the procedure.
    - ◆ No: This ends the procedure.

Parent topic: [Service processor isolation procedures](#)

---

## Model ESCALA PL 1650R-L+ and ESCALA PL 850R/PL 1650R/R+ cables

Power cables.

Table 1. Model ESCALA PL 1650R-L+, 9406-570, and ESCALA PL 850R/PL 1650R/R+ cables

| Name | Description                                               | Part number |
|------|-----------------------------------------------------------|-------------|
|      | 9' power cord 250 V 10 A                                  | 39M5151     |
|      | 9' power cord, 250 V, 10 A                                | 39M5219     |
|      | 14' power cord, 200-240 V, 10 A                           | 36L8877     |
|      | 9' power cord, 200-240 V, 15 A                            | 39M5254     |
|      | 9' power cord, 250 V, 10 A                                | 39M5226     |
|      | 9' power cord, 250 V, 10 A                                | 39M5165     |
|      | 9' power cord, 100-127 V, 15 A                            | 39M5247     |
|      | 14' power cord, right angle, 200-240 V, 10 A              | 13F9995     |
|      | 9' power cord, 250 V, 10 A                                | 39K4947     |
|      | 14' power cord, right angle, 200-240 V, 10 A              | 14F0013     |
|      | 4.3 meter power cord, 200 V, 10 A, Denmark                | 13F9998     |
|      | 14' power cord, right angle, 200-240 V 10 A               | 13F9977     |
|      | 14' power cord, 200-240 V, 15 A, IEC320/C19               | 39M5367     |
|      | 14' power cord, 200-240 V, 15 A, IEC320/C13               | 39M5096     |
|      | 14' power cord, 200-240 V, 15 A, IEC320/C13               | 39M5187     |
|      | 14' power cord, right angle, 200-240 V, 10 A, IEC320/C13, | 6952287     |
|      | 14' power cord, right angle, 200-240 V, 10 A, IEC320/C13  | 14F0031     |
|      | 14' power cord, right angle, 200-240 V, 10 A, IEC320/C13  | 14F0049     |
|      | 14' power cord, right angle, 200-240 V, 10 A, IEC320/C13  | 02K0544     |
|      | 14' power cord, 127 V, 15 A                               | 39M5200     |
|      | 14' power cord, 200-240 V, 10 A                           | 39M5331     |
|      | 14' power cord, 200-240 V, 12 A                           | 39M5335     |
|      | 9' power cord, 250 V, 10 A, IEC320/C13                    | 39M5158     |
|      | 9' power cable. 250 V, 10 A, IEC320/C13                   | 39M5130     |
|      | 14' power cord, 200-240 V, 15 A, IEC320/C19               | 39M5359     |
|      | 14' power cord, 250 V, 10 A                               | 24P6877     |
|      | 14' power cord, right angle, 200-240 V, 10 A, IEC320/C13  | 74P4422     |

Parent topic: [Power and signal cables](#)

---

## FSPSP39

This procedure will isolate a DIMM failure after the DIMM FRU failed to correct the problem.

1. Power off the system (see [Powering on and powering off](#)).
2. Place the DIMM that was replaced by the FRU callout back into its original location.
3. Replace the DIMM that is paired with the DIMM FRU that was called out, according to the following table. See [Finding part locations](#) for part numbers and a link to the exchange procedure.

| Model                                        | DIMM pairings                               |
|----------------------------------------------|---------------------------------------------|
| ESCALA PL 250R-L                             | C4, C5<br>C6, C7<br>C8, C9<br>C10, C11      |
| ESCALA PL 250T/R                             | C9, C10<br>C11, C12<br>C13, C14<br>C15, C16 |
| ESCALA PL 450T/R, ESCALA PL 850R/PL 1650R/R+ | C1, C2<br>C3, C4<br>C5, C6<br>C7, C8        |

4. [Perform a slow boot](#).
5. Does the problem persist?
  - ◆ No: This ends the procedure.
  - ◆ Yes: Continue with the next step.
6. Power off the system (see [Powering on and powering off](#)).
7. Replace the board that the DIMM is plugged into using symbolic FRU [MEMBRD](#).
8. [Perform a slow boot](#). This ends the procedure.

Parent topic: [Service processor isolation procedures](#)

---

## FSPSP40

This procedure is a warning due to an invalid login attempt to the service processor.

No replacement action is required, and any other callouts associated with this error may be disregarded.

Parent topic: [Service processor isolation procedures](#)

---

## FSPSP41

This procedure will help you isolate a problem that occurred when trying to access a chip on the I2C bus.

Click the model on which you are working to display the appropriate procedure:

- [Model ESCALA PL 450T/R](#)
- [Models ESCALA PL 250R-L, ESCALA PL 250T/R, ESCALA PL 450T/R,](#)
- [Model ESCALA PL 850R/PL 1650R/R+](#)
- [Models ESCALA PL 3250R and ESCALA PL 6450R](#)

**FSPSP41: Model ESCALA PL 450T/R**

1. Record words 3, 7, and 8 of the primary SRC from the error log.
2. Determine which service processor initiated the I2C operation by using the last byte in word 3 of the primary SRC:
  - ◆ When the last byte in word 3 of the primary SRC is a 10, then service processor 0 initiated the I2C
  - ◆ When the last byte in word 3 of the primary SRC is a 20, then the service processor 1 initiated the I2C

**Note:** The following I2C FRU table refers to the service processor identified in this step as the *originating service processor*.

3. Determine which parts you need to replace.
  - a. Using the following I2C FRU table for model ESCALA PL 450T/R, refer to words 7 and 8 of the primary SRC to locate the I2C FRU list. The I2C FRU list identifies the parts that you need to replace. Click the following link to display the I2C FRU table: [I2C FRU table for model ESCALA PL 450T/R](#)
  - b. Did you find the I2C FRU list?
    - ◇ **Yes:** Continue with the next step.
    - ◇ **No:** Contact your next level of support. **This ends the procedure.**
4. Starting with the first FRU in the list that you located in the table, perform the following:
  - a. Power off the system.
  - b. Replace the FRU. Go to [Finding part locations](#) for location, part number, and exchange information.
  - c. Perform a reset of the service processor from ASMI. Refer to [Rebooting the service processor](#).
  - d. Go to [Perform a slow boot](#), then continue with the next step.
  - e. Is the problem resolved?
    - ◇ **Yes:** This ends the procedure.
    - ◇ **No:** Continue with the next step.
5. Have you replaced all of the FRUs in the list?
  - ◆ **Yes:** Contact your next level of support. This ends the procedure.
  - ◆ **No:** Repeat step 4 for the next FRU in the list.

Table 1. I2C FRU table for model ESCALA PL 450T/R

| Word 7           |                   | Word 8           |                   | I2C FRU list                                |
|------------------|-------------------|------------------|-------------------|---------------------------------------------|
| Leftmost 2 bytes | Rightmost 2 bytes | Leftmost 2 bytes | Rightmost 2 bytes |                                             |
| 0000             | 00FF              | 00FF             | 00A2              | 1. System backplane                         |
| 0002             | 00FF              | 00FF             | 00A8              |                                             |
| 0003             | 00FF              | 00FF             | 0090              | 1. Control panel<br>2. System backplane     |
|                  |                   |                  | 00A0              |                                             |
|                  |                   |                  | 00B4              |                                             |
| 0004             | 00FF              | 00FF             | 00A0              | 1. Memory module J0A<br>2. System backplane |
| 0004             | 00FF              | 00FF             | 00A2              | 1. Memory module J2D<br>2. System backplane |
| 0004             | 00FF              | 00FF             | 00A4              |                                             |



Service provider information

|      |      |      |      |                                              |
|------|------|------|------|----------------------------------------------|
|      |      |      |      | 1. Memory module J0C<br>2. System backplane  |
| 0004 | 00FF | 00FF | 00A6 | 1. Memory module J2B<br>2. System backplane  |
| 0004 | 00FF | 00FF | 00A8 | 1. Memory module J0B<br>2. System backplane  |
| 0004 | 00FF | 00FF | 00AA | 1. Memory module J2C<br>2. System backplane  |
| 0004 | 00FF | 00FF | 00AC | 1. Memory module J0D<br>2. System backplane  |
| 0004 | 00FF | 00FF | 00AE | 1. Memory module J2A<br>2. System backplane  |
| 0004 | 00FF | 00FF | 00C0 | 1. System backplane                          |
| 0005 | 00FF | 00FF | 00C0 | 1. System backplane                          |
| 0006 | 00FF | 00FF | 0010 | 1. System backplane                          |
|      |      |      | 0080 |                                              |
|      |      |      | 00A0 |                                              |
| 0006 | 00FF | 00FF | 00A4 | 1. PCI riser card 2<br>2. System backplane   |
| 0006 | 00FF | 00FF | 00A6 | 1. PCI riser card 1<br>2. System backplane   |
| 0007 | 00FF | 00FF | 0040 | 1. System backplane                          |
|      |      |      | 00A0 |                                              |
| 000B | 00FF | 00FF | 00E0 | 1. Processor core VRM<br>2. System backplane |
| 000C | 00FF | 00FF | 0040 | 1. System backplane                          |
|      |      |      | 00C0 |                                              |
| 000C | 00FF | 00FF | 00E0 | 1. Processor core VRM<br>2. System backplane |

## FSPSP41: Models ESCALA PL 250R-L, ESCALA PL 250T/R, ESCALA PL 450T/R,

Use this procedure to help you isolate a problem that occurred when trying to access a chip on the I2C bus on models ESCALA PL 250R-L, ESCALA PL 250T/R, ESCALA PL 450T/R, .

1. Record words 7 and 8 of the primary SRC from the error log.
2. Determine which parts you need to replace.
  - a. From the following list, click the link to the I2C FRU table that includes the model on which you are working.. In the I2C FRU table, find words 7 and 8 of the primary SRC to locate the I2C FRU list. The I2C FRU list specifies the parts that you need to replace.
    - ◇ [I2C FRU table for models ESCALA PL 250R-L](#)
    - ◇ [I2C FRU table for model ESCALA PL 250T/R](#)
    - ◇ [I2C FRU table for models ESCALA PL 450T/R](#)

## ◇ I2C FRU table for model 5/75

b. Is the model on which you are working in the previous list, and did you find the I2C FRU list?

◇ **Yes:** Continue with the next step.

◇ **No:** Contact your next level of support. **This ends the procedure.**

3. Starting with the first FRU in the list that you located in the table, perform the following:

a. Power off the system.

b. Replace the FRU. Go to [Finding part locations](#) for location, part number, and exchange information.

c. Go to [Perform a slow boot](#), then continue with the next step.

d. Is the problem resolved?

◇ **Yes:** This ends the procedure.

◇ **No:** Continue with the next step.

4. Have you replaced all of the FRUs in the list?

◆ **Yes:** Contact your next level of support. This ends the procedure.

◆ **No:** Repeat step 3 for the next FRU in the list.

Table 1. I2C FRU table for models ESCALA PL 250R-L

| Word 7           |                   | Word 8           |                   | I2C FRU list                                |
|------------------|-------------------|------------------|-------------------|---------------------------------------------|
| Leftmost 2 bytes | Rightmost 2 bytes | Leftmost 2 bytes | Rightmost 2 bytes |                                             |
| 0000             | 00FF              | 00FF             | 00A2              | 1. System backplane                         |
| 0002             | 00FF              | 00FF             | 00A8              |                                             |
| 0003             | 00FF              | 00FF             | 0090              | 1. Control panel<br>2. System backplane     |
|                  |                   |                  | 00A0              |                                             |
|                  |                   |                  | 00B4              |                                             |
| 0004             | 008E              | 0000             | 00C0              | 1. System backplane                         |
| 0004             | 008E              | 0004             | 00A0              | 1. Memory module J0A<br>2. System backplane |
| 0004             | 008E              | 0004             | 00A2              | 1. Memory module J2D<br>2. System backplane |
| 0004             | 008E              | 0004             | 00A4              | 1. Memory module J0C<br>2. System backplane |
| 0004             | 008E              | 0004             | 00A6              | 1. Memory module J2B<br>2. System backplane |
| 0004             | 008E              | 0004             | 00A8              | 1. Memory module J0B<br>2. System backplane |
| 0004             | 008E              | 0004             | 00AA              | 1. Memory module J2C<br>2. System backplane |
| 0004             | 008E              | 0004             | 00AC              | 1. Memory module J0D<br>2. System backplane |
| 0004             | 008E              | 0004             | 00AE              | 1. Memory module J2A<br>2. System backplane |
| 0004             | 008E              | 0008             | 00C0              | 1. System backplane                         |
| 0004             | 00FF              | 00FF             | 00C2              |                                             |
| 0005             | 00FF              | 00FF             | 0014              |                                             |

Service provider information

|      |      |      |      |                                                 |
|------|------|------|------|-------------------------------------------------|
|      |      |      |      | 1. PCI adapter enclosure<br>2. System backplane |
| 0006 | 00FF | 00FF | 0010 | 1. System backplane                             |
|      |      |      | 0080 |                                                 |
|      |      |      | 00A0 |                                                 |
|      |      |      | 00A4 |                                                 |
|      |      |      | 00AC |                                                 |
| 0007 | 00FF | 00FF | 0040 |                                                 |
|      |      |      | 00A0 |                                                 |
| 000C | 00FF | 00FF | 0040 |                                                 |
|      |      |      | 00C0 |                                                 |

Table 2. I2C FRU table for model ESCALA PL 250T/R

| Word 7           |                   | Word 8           |                   | I2C FRU list                                                                                        |
|------------------|-------------------|------------------|-------------------|-----------------------------------------------------------------------------------------------------|
| Leftmost 2 bytes | Rightmost 2 bytes | Leftmost 2 bytes | Rightmost 2 bytes |                                                                                                     |
| 0000             | 00FF              | 00FF             | 00A0              | 1. Service processor card<br>2. System backplane                                                    |
| 0002             | 00FF              | 00FF             | 00A8              | 1. Service processor card                                                                           |
|                  |                   |                  | 00C0              |                                                                                                     |
| 0003             | 00FF              | 00FF             | 0090              | 1. Control panel cable<br>2. Control panel<br>3. Service processor card<br>4. Media drive backplane |
|                  |                   |                  | 0092              |                                                                                                     |
|                  |                   |                  | 00A0              |                                                                                                     |
|                  |                   |                  | 00B4              |                                                                                                     |
| 0004             | 008E              | 0000             | 00C0              | 1. Service processor card<br>2. System backplane                                                    |
|                  |                   |                  | 00C2              |                                                                                                     |
| 0004             | 008E              | 0004             | 00A0              | 1. Memory module 1<br>2. Service processor card<br>3. System backplane                              |
| 0004             | 008E              | 0004             | 00A2              | 1. Memory module 5<br>2. Service processor card<br>3. System backplane                              |
| 0004             | 008E              | 0004             | 00A4              | 1. Memory module 3<br>2. Service processor card<br>3. System backplane                              |
| 0004             | 008E              | 0004             | 00A6              | 1. Memory module 7<br>2. Service processor card<br>3. System backplane                              |
| 0004             | 008E              | 0004             | 00A8              | 1. Memory module 2<br>2. Service processor card<br>3. System backplane                              |
| 0004             | 008E              | 0004             | 00AA              | 1. Memory module 6<br>2. Service processor card<br>3. System backplane                              |
| 0004             | 008E              | 0004             | 00AC              | 1. Memory module 4                                                                                  |

Service provider information

|      |      |      |      |                                                                                   |
|------|------|------|------|-----------------------------------------------------------------------------------|
|      |      |      |      | 2. Service processor card<br>3. System backplane                                  |
| 0004 | 008E | 0004 | 00AE | 1. Memory module 8<br>2. Service processor card<br>3. System backplane            |
| 0004 | 008E | 0008 | 00C0 | 1. Service processor card<br>2. System backplane                                  |
| 0004 | 00FF | 00FF | 00C2 |                                                                                   |
| 0006 | 00FF | 00FF | 0010 |                                                                                   |
|      |      |      | 0012 |                                                                                   |
|      |      |      | 0080 |                                                                                   |
|      |      |      | 00A0 |                                                                                   |
|      |      |      | 00A4 |                                                                                   |
| 0007 | 00FF | 00FF | 0040 | 1. Disk drive (5-8) backplane<br>2. Service processor card<br>3. System backplane |
|      |      |      | 00A0 |                                                                                   |
|      |      |      | 0044 | 1. Disk drive (1-4) backplane<br>2. Service processor card<br>3. System backplane |
| 00A4 |      |      |      |                                                                                   |
| 0009 | 00FF | 00FF | 00A2 | 1. Media drive backplane<br>2. Service processor card<br>3. System backplane      |
| 000C | 00FF | 00FF | 0042 | 1. Service processor card<br>2. System backplane                                  |
|      |      |      | 00C0 |                                                                                   |

Table 3. I2C FRU table for models ESCALA PL 450T/R

| Word 7           |                   | Word 8           |                   | I2C FRU list        |
|------------------|-------------------|------------------|-------------------|---------------------|
| Leftmost 2 bytes | Rightmost 2 bytes | Leftmost 2 bytes | Rightmost 2 bytes |                     |
| 0000             | 00FF              | 00FF             | 0046              | 1. System backplane |
|                  |                   |                  | 00A0              |                     |
|                  |                   |                  | 00C0              |                     |
|                  |                   |                  | 00C2              |                     |
|                  |                   |                  | 00C4              |                     |
| 0002             | 00FF              | 00FF             | 00A8              |                     |
|                  |                   |                  | 00C0              |                     |
| 0006             | 00FF              | 00FF             | 0010              |                     |
|                  |                   |                  | 0012              |                     |
|                  |                   |                  | 0080              |                     |
|                  |                   |                  | 00A0              |                     |
|                  |                   |                  | 00A4              |                     |
|                  |                   |                  | 00A8              |                     |
|                  |                   |                  | 00AC              |                     |
| 0003             | 00FF              | 00FF             | 0090              |                     |

Service provider information

|      |      |      |      |                                                                                                                                             |
|------|------|------|------|---------------------------------------------------------------------------------------------------------------------------------------------|
|      |      |      | 0092 | 1. Control panel cable<br>2. Control panel<br>3. Media drive backplane<br>4. System backplane                                               |
|      |      |      | 00A0 |                                                                                                                                             |
|      |      |      | 00B4 |                                                                                                                                             |
| 0004 | 00FF | 00FF | 00A0 | 1. Memory module 1 on processor card 1<br>2. All remaining memory modules on Processor card 1<br>3. Processor card 1<br>4. System backplane |
| 0004 | 00FF | 00FF | 00A2 | 1. Memory module 8 on processor card 1<br>2. All remaining memory modules on Processor card 1<br>3. Processor card 1<br>4. System backplane |
| 0004 | 00FF | 00FF | 00A4 | 1. Memory module 3 on processor card 1<br>2. All remaining memory modules on Processor card 1<br>3. Processor card 1<br>4. System backplane |
| 0004 | 00FF | 00FF | 00A6 | 1. Memory module 6 on processor card 1<br>2. All remaining memory modules on Processor card 1<br>3. Processor card 1<br>4. System backplane |
| 0004 | 00FF | 00FF | 00A8 | 1. Memory module 2 on processor card 1<br>2. All remaining memory modules on Processor card 1<br>3. Processor card 1<br>4. System backplane |
| 0004 | 00FF | 00FF | 00AA | 1. Memory module 7 on processor card 1<br>2. All remaining memory modules on Processor card 1<br>3. Processor card 1<br>4. System backplane |
| 0004 | 00FF | 00FF | 00AC | 1. Memory module 4 on processor card 1<br>2. All remaining memory modules on Processor card 1<br>3. Processor card 1<br>4. System backplane |
| 0004 | 00FF | 00FF | 00AE | 1. Memory module 5 on processor card 1<br>2. All remaining memory modules on Processor card 1<br>3. Processor card 1<br>4. System backplane |
| 0005 | 00FF | 00FF | 0042 | 1. Processor card 1<br>2. System backplane                                                                                                  |
|      |      |      | 00C0 |                                                                                                                                             |
| 0007 | 00FF | 00FF | 0040 | 1. Disk drive (1-4) backplane<br>2. System backplane                                                                                        |
|      |      |      | 00A0 |                                                                                                                                             |
| 0008 | 00FF | 00FF | 00A2 | 1. Media drive backplane<br>2. System backplane                                                                                             |
| 0009 | 00FF | 00FF | 0044 |                                                                                                                                             |

Service provider information

|      |      |      |      |                                                                                                                                                                                                                 |
|------|------|------|------|-----------------------------------------------------------------------------------------------------------------------------------------------------------------------------------------------------------------|
|      |      |      | 00A4 | <ol style="list-style-type: none"> <li>1. Disk drive (5-8) backplane</li> <li>2. System backplane</li> </ol>                                                                                                    |
| 000A | 00FF | 00FF | 00A0 | <ol style="list-style-type: none"> <li>1. Memory module 1 on processor card 2</li> <li>2. All remaining memory modules on Processor card 2</li> <li>3. Processor card 2</li> <li>4. System backplane</li> </ol> |
| 000A | 00FF | 00FF | 00A2 | <ol style="list-style-type: none"> <li>1. Memory module 8 on processor card 2</li> <li>2. All remaining memory modules on Processor card 2</li> <li>3. Processor card 2</li> <li>4. System backplane</li> </ol> |
| 000A | 00FF | 00FF | 00A4 | <ol style="list-style-type: none"> <li>1. Memory module 3 on processor card 2</li> <li>2. All remaining memory modules on Processor card 2</li> <li>3. Processor card 2</li> <li>4. System backplane</li> </ol> |
| 000A | 00FF | 00FF | 00A6 | <ol style="list-style-type: none"> <li>1. Memory module 6 on processor card 2</li> <li>2. All remaining memory modules on Processor card 2</li> <li>3. Processor card 2</li> <li>4. System backplane</li> </ol> |
| 000A | 00FF | 00FF | 00A8 | <ol style="list-style-type: none"> <li>1. Memory module 7 on processor card 2</li> <li>2. All remaining memory modules on Processor card 2</li> <li>3. Processor card 2</li> <li>4. System backplane</li> </ol> |
| 000A | 00FF | 00FF | 00AA | <ol style="list-style-type: none"> <li>1. Memory module 4 on processor card 2</li> <li>2. All remaining memory modules on Processor card 2</li> <li>3. Processor card 2</li> <li>4. System backplane</li> </ol> |
| 000A | 00FF | 00FF | 00AC | <ol style="list-style-type: none"> <li>1. Memory module 5 on processor card 2</li> <li>2. All remaining memory modules on Processor card 2</li> <li>3. Processor card 2</li> <li>4. System backplane</li> </ol> |
| 000A | 00FF | 00FF | 00AE | <ol style="list-style-type: none"> <li>1. Memory module 1 on processor card 2</li> <li>2. All remaining memory modules on Processor card 2</li> <li>3. Processor card 2</li> <li>4. System backplane</li> </ol> |
| 000B | 00FF | 00FF | 0042 | <ol style="list-style-type: none"> <li>1. Processor card 2</li> <li>2. System backplane</li> </ol>                                                                                                              |
|      |      |      | 00C0 |                                                                                                                                                                                                                 |
| 000C | 00FF | 00FF | 00A0 | <ol style="list-style-type: none"> <li>1. RIO/HSL adapter card</li> <li>2. System backplane</li> </ol>                                                                                                          |
|      |      |      | 00C0 |                                                                                                                                                                                                                 |

Table 4. I2C FRU table for model 5/75

| Word 7           |                   | Word 8           |                   | I2C FRU list                                                                                     |
|------------------|-------------------|------------------|-------------------|--------------------------------------------------------------------------------------------------|
| Leftmost 2 bytes | Rightmost 2 bytes | Leftmost 2 bytes | Rightmost 2 bytes |                                                                                                  |
| 0000             | 00FF              | 00FF             | 00A8              | 1. System backplane                                                                              |
| 0001             | 00FF              | 00FF             | 00A8              | 1. Processor backplane<br>2. System backplane                                                    |
| 0002             | 00FF              | 00FF             | 00A8              | 1. System backplane                                                                              |
| 0003             | 00FF              | 00FF             | 00A8              |                                                                                                  |
| 0004             | 00FF              | 00FF             | 0080              |                                                                                                  |
|                  |                   |                  | 00A4              |                                                                                                  |
|                  |                   |                  | 00A8              |                                                                                                  |
|                  |                   |                  | 00AC              |                                                                                                  |
| 0005             | 00FF              | 00FF             | 00A8              | 1. Processor backplane<br>2. System backplane                                                    |
| 0006             | 0052              | 0000             | 00A2              | 1. Memory module 3<br>2. Memory modules 1, 6, 8<br>3. Processor backplane<br>4. System backplane |
| 0006             | 0052              | 0000             | 00A4              | 1. Memory module 1<br>2. Memory modules 3, 6, 8<br>3. Processor backplane<br>4. System backplane |
| 0006             | 0052              | 0000             | 00A8              | 1. Memory module 6<br>2. Memory modules 1, 3, 8<br>3. Processor backplane<br>4. System backplane |
| 0006             | 0052              | 0000             | 00AE              | 1. Memory module 8<br>2. Memory modules 1, 3, 6<br>3. Processor backplane<br>4. System backplane |
| 0006             | 0052              | 0001             | 00A2              | 1. Memory module 4<br>2. Memory modules 2, 5, 7<br>3. Processor backplane<br>4. System backplane |
| 0006             | 0052              | 0001             | 00A4              | 1. Memory module 2<br>2. Memory modules 4, 5, 7<br>3. Processor backplane<br>4. System backplane |
| 0006             | 0052              | 0001             | 00A8              | 1. Memory module 5<br>2. Memory modules 2, 4, 7<br>3. Processor backplane<br>4. System backplane |
| 0006             | 0052              | 0001             | 00AE              | 1. Memory module 7<br>2. Memory modules 2, 4, 5<br>3. Processor backplane<br>4. System backplane |
| 0006             | 0052              | 0002             | 00A2              | 1. Memory module 38                                                                              |

## Service provider information

|      |      |      |      |                                                                                                                                                                          |
|------|------|------|------|--------------------------------------------------------------------------------------------------------------------------------------------------------------------------|
|      |      |      |      | <ul style="list-style-type: none"> <li>2. Memory modules 33, 35, 40</li> <li>3. Processor backplane</li> <li>4. System backplane</li> </ul>                              |
| 0006 | 0052 | 0002 | 00A4 | <ul style="list-style-type: none"> <li>1. Memory module 40</li> <li>2. Memory modules 33, 35, 38</li> <li>3. Processor backplane</li> <li>4. System backplane</li> </ul> |
| 0006 | 0052 | 0002 | 00A8 | <ul style="list-style-type: none"> <li>1. Memory module 35</li> <li>2. Memory modules 33, 38, 40</li> <li>3. Processor backplane</li> <li>4. System backplane</li> </ul> |
| 0006 | 0052 | 0002 | 00AE | <ul style="list-style-type: none"> <li>1. Memory module 33</li> <li>2. Memory modules 35, 38, 40</li> <li>3. Processor backplane</li> <li>4. System backplane</li> </ul> |
| 0006 | 0052 | 0003 | 00A2 | <ul style="list-style-type: none"> <li>1. Memory module 37</li> <li>2. Memory modules 34, 36, 39</li> <li>3. Processor backplane</li> <li>4. System backplane</li> </ul> |
| 0006 | 0052 | 0003 | 00A4 | <ul style="list-style-type: none"> <li>1. Memory module 39</li> <li>2. Memory modules 34, 36, 37</li> <li>3. Processor backplane</li> <li>4. System backplane</li> </ul> |
| 0006 | 0052 | 0003 | 00A8 | <ul style="list-style-type: none"> <li>1. Memory module 36</li> <li>2. Memory modules 34, 37, 39</li> <li>3. Processor backplane</li> <li>4. System backplane</li> </ul> |
| 0006 | 0052 | 0003 | 00AE | <ul style="list-style-type: none"> <li>1. Memory module 34</li> <li>2. Memory modules 36, 37, 39</li> <li>3. Processor backplane</li> <li>4. System backplane</li> </ul> |
| 0006 | 0052 | 0004 | 00A2 | <ul style="list-style-type: none"> <li>1. Memory module 11</li> <li>2. Memory modules 9, 14, 16</li> <li>3. Processor backplane</li> <li>4. System backplane</li> </ul>  |
| 0006 | 0052 | 0004 | 00A4 | <ul style="list-style-type: none"> <li>1. Memory module 9</li> <li>2. Memory modules 11, 14, 16</li> <li>3. Processor backplane</li> <li>4. System backplane</li> </ul>  |
| 0006 | 0052 | 0004 | 00A8 | <ul style="list-style-type: none"> <li>1. Memory module 14</li> <li>2. Memory modules 9, 11, 16</li> <li>3. Processor backplane</li> <li>4. System backplane</li> </ul>  |
| 0006 | 0052 | 0004 | 00AE | <ul style="list-style-type: none"> <li>1. Memory module 16</li> <li>2. Memory modules 9, 11, 14</li> <li>3. Processor backplane</li> <li>4. System backplane</li> </ul>  |
| 0006 | 0052 | 0005 | 00A2 | <ul style="list-style-type: none"> <li>1. Memory module 12</li> <li>2. Memory modules 10, 13, 15</li> <li>3. Processor backplane</li> </ul>                              |



## Service provider information

|      |      |      |      |                                                                                                                                                                          |
|------|------|------|------|--------------------------------------------------------------------------------------------------------------------------------------------------------------------------|
|      |      |      |      | 4. System backplane                                                                                                                                                      |
| 0006 | 0052 | 0004 | 00A4 | <ol style="list-style-type: none"> <li>1. Memory module 10</li> <li>2. Memory modules 12, 13, 15</li> <li>3. Processor backplane</li> <li>4. System backplane</li> </ol> |
| 0006 | 0052 | 0004 | 00A8 | <ol style="list-style-type: none"> <li>1. Memory module 13</li> <li>2. Memory modules 10, 12, 15</li> <li>3. Processor backplane</li> <li>4. System backplane</li> </ol> |
| 0006 | 0052 | 0004 | 00AE | <ol style="list-style-type: none"> <li>1. Memory module 15</li> <li>2. Memory modules 10, 12, 13</li> <li>3. Processor backplane</li> <li>4. System backplane</li> </ol> |
| 0006 | 0052 | 0006 | 00A2 | <ol style="list-style-type: none"> <li>1. Memory module 46</li> <li>2. Memory modules 41, 43, 48</li> <li>3. Processor backplane</li> <li>4. System backplane</li> </ol> |
| 0006 | 0052 | 0006 | 00A4 | <ol style="list-style-type: none"> <li>1. Memory module 48</li> <li>2. Memory modules 41, 43, 46</li> <li>3. Processor backplane</li> <li>4. System backplane</li> </ol> |
| 0006 | 0052 | 0006 | 00A8 | <ol style="list-style-type: none"> <li>1. Memory module 43</li> <li>2. Memory modules 41, 46, 48</li> <li>3. Processor backplane</li> <li>4. System backplane</li> </ol> |
| 0006 | 0052 | 0006 | 00AE | <ol style="list-style-type: none"> <li>1. Memory module 41</li> <li>2. Memory modules 43, 46, 48</li> <li>3. Processor backplane</li> <li>4. System backplane</li> </ol> |
| 0006 | 0052 | 0007 | 00A2 | <ol style="list-style-type: none"> <li>1. Memory module 45</li> <li>2. Memory modules 42, 44, 47</li> <li>3. Processor backplane</li> <li>4. System backplane</li> </ol> |
| 0006 | 0052 | 0007 | 00A4 | <ol style="list-style-type: none"> <li>1. Memory module 47</li> <li>2. Memory modules 42, 44, 45</li> <li>3. Processor backplane</li> <li>4. System backplane</li> </ol> |
| 0006 | 0052 | 0007 | 00A8 | <ol style="list-style-type: none"> <li>1. Memory module 44</li> <li>2. Memory modules 42, 45, 47</li> <li>3. Processor backplane</li> <li>4. System backplane</li> </ol> |
| 0006 | 0052 | 0007 | 00AE | <ol style="list-style-type: none"> <li>1. Memory module 42</li> <li>2. Memory modules 44, 45, 47</li> <li>3. Processor backplane</li> <li>4. System backplane</li> </ol> |
| 0006 | 0052 | 0008 | 00A2 | <ol style="list-style-type: none"> <li>1. Memory module 19</li> <li>2. Memory modules 17, 22, 24</li> <li>3. Processor backplane</li> <li>4. System backplane</li> </ol> |

## Service provider information

|      |      |      |      |                                                                                                                                                                          |
|------|------|------|------|--------------------------------------------------------------------------------------------------------------------------------------------------------------------------|
| 0006 | 0052 | 0008 | 00A4 | <ol style="list-style-type: none"> <li>1. Memory module 17</li> <li>2. Memory modules 19, 22, 24</li> <li>3. Processor backplane</li> <li>4. System backplane</li> </ol> |
| 0006 | 0052 | 0008 | 00A8 | <ol style="list-style-type: none"> <li>1. Memory module 22</li> <li>2. Memory modules 17, 19, 24</li> <li>3. Processor backplane</li> <li>4. System backplane</li> </ol> |
| 0006 | 0052 | 0008 | 00AE | <ol style="list-style-type: none"> <li>1. Memory module 24</li> <li>2. Memory modules 17, 19, 22</li> <li>3. Processor backplane</li> <li>4. System backplane</li> </ol> |
| 0006 | 0052 | 0009 | 00A2 | <ol style="list-style-type: none"> <li>1. Memory module 20</li> <li>2. Memory modules 18, 21, 23</li> <li>3. Processor backplane</li> <li>4. System backplane</li> </ol> |
| 0006 | 0052 | 0009 | 00A4 | <ol style="list-style-type: none"> <li>1. Memory module 18</li> <li>2. Memory modules 20, 21, 23</li> <li>3. Processor backplane</li> <li>4. System backplane</li> </ol> |
| 0006 | 0052 | 0009 | 00A8 | <ol style="list-style-type: none"> <li>1. Memory module 21</li> <li>2. Memory modules 18, 20, 23</li> <li>3. Processor backplane</li> <li>4. System backplane</li> </ol> |
| 0006 | 0052 | 0009 | 00AE | <ol style="list-style-type: none"> <li>1. Memory module 23</li> <li>2. Memory modules 18, 20, 21</li> <li>3. Processor backplane</li> <li>4. System backplane</li> </ol> |
| 0006 | 0052 | 000A | 00A2 | <ol style="list-style-type: none"> <li>1. Memory module 54</li> <li>2. Memory modules 49, 51, 56</li> <li>3. Processor backplane</li> <li>4. System backplane</li> </ol> |
| 0006 | 0052 | 000A | 00A4 | <ol style="list-style-type: none"> <li>1. Memory module 56</li> <li>2. Memory modules 49, 51, 54</li> <li>3. Processor backplane</li> <li>4. System backplane</li> </ol> |
| 0006 | 0052 | 000A | 00A8 | <ol style="list-style-type: none"> <li>1. GX adapter 0 (Un-P2-C65)</li> <li>2. Processor Backplane</li> <li>3. System backplane</li> </ol>                               |
| 0006 | 0052 | 000A | 00AE | <ol style="list-style-type: none"> <li>1. Memory module 49</li> <li>2. Memory modules 51, 54, 56</li> <li>3. Processor backplane</li> <li>4. System backplane</li> </ol> |
| 0006 | 0052 | 000B | 00A2 | <ol style="list-style-type: none"> <li>1. Memory module 53</li> <li>2. Memory modules 50, 52, 55</li> <li>3. Processor backplane</li> <li>4. System backplane</li> </ol> |
| 0006 | 0052 | 000B | 00A4 | <ol style="list-style-type: none"> <li>1. Memory module 55</li> <li>2. Memory modules 50, 52, 53</li> <li>3. Processor backplane</li> </ol>                              |

Service provider information

|      |      |      |      |                                                                                                                                                                          |
|------|------|------|------|--------------------------------------------------------------------------------------------------------------------------------------------------------------------------|
|      |      |      |      | 4. System backplane                                                                                                                                                      |
| 0006 | 0052 | 000B | 00A8 | <ol style="list-style-type: none"> <li>1. GX adapter 0 (Un-P2-C66)</li> <li>2. Processor Backplane</li> <li>3. System backplane</li> </ol>                               |
| 0006 | 0052 | 000B | 00AE | <ol style="list-style-type: none"> <li>1. Memory module 50</li> <li>2. Memory modules 52, 53, 55</li> <li>3. Processor backplane</li> <li>4. System backplane</li> </ol> |
| 0006 | 0052 | 000C | 00A2 | <ol style="list-style-type: none"> <li>1. Memory module 27</li> <li>2. Memory modules 25, 30, 32</li> <li>3. Processor backplane</li> <li>4. System backplane</li> </ol> |
| 0006 | 0052 | 000C | 00A4 | <ol style="list-style-type: none"> <li>1. Memory module 25</li> <li>2. Memory modules 27, 30, 32</li> <li>3. Processor backplane</li> <li>4. System backplane</li> </ol> |
| 0006 | 0052 | 000C | 00A8 | <ol style="list-style-type: none"> <li>1. Memory module 30</li> <li>2. Memory modules 25, 27, 32</li> <li>3. Processor backplane</li> <li>4. System backplane</li> </ol> |
| 0006 | 0052 | 000C | 00AE | <ol style="list-style-type: none"> <li>1. Memory module 32</li> <li>2. Memory modules 25, 27, 30</li> <li>3. Processor backplane</li> <li>4. System backplane</li> </ol> |
| 0006 | 0052 | 000D | 00A2 | <ol style="list-style-type: none"> <li>1. Memory module 28</li> <li>2. Memory modules 26, 29, 31</li> <li>3. Processor backplane</li> <li>4. System backplane</li> </ol> |
| 0006 | 0052 | 000D | 00A4 | <ol style="list-style-type: none"> <li>1. Memory module 26</li> <li>2. Memory modules 28, 29, 31</li> <li>3. Processor backplane</li> <li>4. System backplane</li> </ol> |
| 0006 | 0052 | 000D | 00A8 | <ol style="list-style-type: none"> <li>1. Memory module 29</li> <li>2. Memory modules 26, 28, 31</li> <li>3. Processor backplane</li> <li>4. System backplane</li> </ol> |
| 0006 | 0052 | 000D | 00AE | <ol style="list-style-type: none"> <li>1. Memory module 31</li> <li>2. Memory modules 26, 28, 29</li> <li>3. Processor backplane</li> <li>4. System backplane</li> </ol> |
| 0006 | 0052 | 000E | 00A2 | <ol style="list-style-type: none"> <li>1. Memory module 62</li> <li>2. Memory modules 57, 59, 64</li> <li>3. Processor backplane</li> <li>4. System backplane</li> </ol> |
| 0006 | 0052 | 000E | 00A4 | <ol style="list-style-type: none"> <li>1. Memory module 64</li> <li>2. Memory modules 57, 59, 62</li> <li>3. Processor backplane</li> <li>4. System backplane</li> </ol> |
| 0006 | 0052 | 000E | 00A8 |                                                                                                                                                                          |

Service provider information

|      |      |      |      |                                                                                                                                                                          |
|------|------|------|------|--------------------------------------------------------------------------------------------------------------------------------------------------------------------------|
|      |      |      |      | <ol style="list-style-type: none"> <li>1. Memory module 59</li> <li>2. Memory modules 57, 62, 64</li> <li>3. Processor backplane</li> <li>4. System backplane</li> </ol> |
| 0006 | 0052 | 000E | 00AE | <ol style="list-style-type: none"> <li>1. Memory module 57</li> <li>2. Memory modules 59, 62, 64</li> <li>3. Processor backplane</li> <li>4. System backplane</li> </ol> |
| 0006 | 0052 | 000F | 00A2 | <ol style="list-style-type: none"> <li>1. Memory module 61</li> <li>2. Memory modules 58, 60, 63</li> <li>3. Processor backplane</li> <li>4. System backplane</li> </ol> |
| 0006 | 0052 | 000F | 00A4 | <ol style="list-style-type: none"> <li>1. Memory module 63</li> <li>2. Memory modules 58, 60, 61</li> <li>3. Processor backplane</li> <li>4. System backplane</li> </ol> |
| 0006 | 0052 | 000F | 00A8 | <ol style="list-style-type: none"> <li>1. Memory module 60</li> <li>2. Memory modules 58, 61, 63</li> <li>3. Processor backplane</li> <li>4. System backplane</li> </ol> |
| 0006 | 0052 | 000F | 00AE | <ol style="list-style-type: none"> <li>1. Memory module 58</li> <li>2. Memory modules 60, 61, 63</li> <li>3. Processor Backplane</li> <li>4. System backplane</li> </ol> |
| 0006 | 0052 | 0010 | 0040 | <ol style="list-style-type: none"> <li>1. GX adapter 0 (Un-P2-C65)</li> <li>2. Processor Backplane</li> <li>3. System backplane</li> </ol>                               |
| 0006 | 0052 | 0010 | 00C6 | <ol style="list-style-type: none"> <li>1. GX adapter 0 (Un-P2-C65)</li> <li>2. Processor Backplane</li> <li>3. System backplane</li> </ol>                               |
|      |      |      | 00C8 |                                                                                                                                                                          |
| 0006 | 0052 | 0011 | 0040 | <ol style="list-style-type: none"> <li>1. GX adapter 0 (Un-P2-C66)</li> <li>2. Processor Backplane</li> <li>3. System backplane</li> </ol>                               |
| 0006 | 0052 | 0011 | 00C6 | <ol style="list-style-type: none"> <li>1. GX adapter 0 (Un-P2-C66)</li> <li>2. Processor Backplane</li> <li>3. System backplane</li> </ol>                               |
|      |      |      | 00C8 |                                                                                                                                                                          |
| 0006 | 00FF | 00FF | 0052 | <ol style="list-style-type: none"> <li>1. Processor backplane</li> <li>2. System backplane</li> </ol>                                                                    |
| 0008 | 00FF | 00FF | 00C2 | <ol style="list-style-type: none"> <li>1. System backplane</li> </ol>                                                                                                    |
|      |      |      | 00C4 |                                                                                                                                                                          |
| 0009 | 00FF | 00FF | 00C2 | <ol style="list-style-type: none"> <li>1. Processor backplane</li> <li>2. System backplane</li> </ol>                                                                    |
| 000B | 0052 | 0003 | 0012 | <ol style="list-style-type: none"> <li>1. System backplane</li> </ol>                                                                                                    |
|      | 00FF | 00FF | 0052 |                                                                                                                                                                          |
| 000C | 00FF | 00FF | 0010 |                                                                                                                                                                          |

## FSPSP41: Model ESCALA PL 850R/PL 1650R/R+

Use this procedure to help you isolate a problem that occurred when trying to access a chip on the I2C bus on model ESCALA PL 850R/PL 1650R/R+ (4-way or 8-way through 16-way).

1. Record words 3, 7, and 8 from the primary system reference code (SRC) of the error log.
2. Determine the enclosure that contains the service processor that started the I2C operation.

**Note:** The remainder of this procedure refers to this enclosure as the *FSP enclosure*.

Refer to the last byte in word 3 of the primary SRC to find the service processor enclosure:

- a. If the last byte is a 10, then the primary unit service processor started the I2C.
- b. If the last byte is a 20, then the secondary unit 1 service processor started the I2C.
- c. If the last byte is a 30, use one of the following methods to determine the enclosure:

If you have access to the Advanced System Management Interface (ASMI), log on and display the details of the service processor error log. Using the Platform Event Log id (shown in the first table of each detail of the log), look at the first byte.

◇ If the first byte is a 50, then the primary unit service processor started the I2C.

◇ If the first byte is a 51, then the secondary unit 1 service processor started the I2C.

If you have access to an Hardware Management Console (HMC), log in as PE user and bring up Manage Serviceable Events under the Service Focal Point screen. Display the events for the corresponding service processor system, then double-click the system to see the details. Look at the Field Platform log ID, which contains a decimal value that you need to convert to a hexadecimal value.

◇ If the first byte of the hexadecimal value is a 50, then the primary unit service processor started the I2C.

◇ If the first byte of the hexadecimal value is a 51, then the secondary unit 1 service processor started the I2C.

3. Determine which enclosure contains the target I2C device.

**Note:** The remainder of this procedure refers to the enclosure that contains the I2C device as the *target enclosure*.

In the I2C Target enclosure table, find word 7 from the primary SRC. The enclosure listed beside word 7 is the target enclosures. Click the following link to display the I2C Target enclosure table: [I2C Target enclosures for model ESCALA PL 850R/PL 1650R/R+ \(4-way or 8-way through 16-way\)](#)

4. Does word 7 have a match in the I2C Target enclosure table?
  - ◆ **Yes:** Continue with the step 6.
  - ◆ **No:** Continue with the next step.
5. The upper word of word 7 does not have a match in the I2C Target enclosure table. Use the following statements to determine which enclosure contains the target I2C device:
  - a. If the upper word of word 7 is either 0002 or 0003, then the FSP enclosure and the target enclosure are the same.
  - b. If the upper word of word 7 is either 0000 or 0001, then refer to the following conditions
    - i. i. If the FSP enclosure is the primary unit, then the target enclosure is the secondary unit
    - ii. If the FSP enclosure is secondary unit 1, then the target enclosure is the primary unit.
6. Determine which parts you need to replace on the target enclosure.
  - a. Using the following I2C FRU table for model ESCALA PL 850R/PL 1650R/R+, refer to words 7 and 8 of the primary SRC to locate the I2C FRU list. The I2C FRU list identifies the parts that you need to replace. Click the following link to display the I2C FRU table: [I2C FRU table for model ESCALA PL 850R/PL 1650R/R+ \(4-way or 8-way through 16-way\)](#)
  - b. Did you find the I2C FRU list?
    - ◇ **Yes:** Continue with the next step.

- ◇ **No:** Contact your next level of support. **This ends the procedure.**
7. Starting with the first FRU in the list that you located the I2C FRU table, do the following:
- Power off the system.
  - Replace the FRU on the target enclosure. Go to [Finding part locations](#) for location, part number, and exchange information.
  - Go to [Perform a slow boot](#), then continue with the next step.
  - Is the problem resolved?
    - ◇ **Yes: This ends the procedure.**
    - ◇ **No:** Continue with the next step.
8. Have you replaced all of the FRUs in the list?
  - ◆ **No:** Repeat step 7 for the next FRU in the list.
  - ◆ **Yes:** Continue with the next step.
9. Replace the following FRUs, one at a time and in the order listed. After you replace each FRU, perform a slow boot until the problem is resolved. For more information, see [Perform a slow boot](#).
- System/service processor cable connected from the service processor enclosure to the target enclosure
  - Service processor on the service processor enclosure
  - I/O backplane on the target enclosure
  - I/O backplane on the service processor enclosure
10. Is the problem resolved?
  - ◆ **Yes: This ends the procedure.**
  - ◆ **No:** Contact your next level of support. **This ends the procedure.**

Table 1. I2C Target enclosures for model ESCALA PL 850R/PL 1650R/R+ (4-way or 8-way through 16-way)

| Word 7: Leftmost 2 bytes | Enclosure        |
|--------------------------|------------------|
| 0004                     | Secondary unit 3 |
| 0005                     | Secondary unit 2 |
| 0006                     | Secondary unit 1 |
| 000B                     | Primary unit     |

Table 2. I2C FRU table for model ESCALA PL 850R/PL 1650R/R+ (4-way or 8-way through 16-way)

| Word 7            | Word 8           | Word 8            | I2C FRU list                                                                                  |
|-------------------|------------------|-------------------|-----------------------------------------------------------------------------------------------|
| Rightmost 2 bytes | Leftmost 2 bytes | Rightmost 2 bytes |                                                                                               |
| 0000              | 0000             | 00A8              | 1. Service processor card (if present in target enclosure)                                    |
|                   |                  | 00C0              |                                                                                               |
| 0052              | 0001             | 00A0              | 1. Service processor card (if present in target enclosure)<br>2. I/O backplane                |
|                   |                  | 0080              |                                                                                               |
|                   |                  | 00A0              |                                                                                               |
|                   |                  | 00A4              |                                                                                               |
|                   |                  | 00A8              |                                                                                               |
|                   |                  | 00AC              |                                                                                               |
|                   | 0002             | 00A0              |                                                                                               |
| 0052              | 0003             | 0092              | 1. All memory modules (1-8) on processor card 1<br>2. Processor card 1                        |
| 0052              | 0003             | 00A0              | 1. Memory module 8 on Processor card 1<br>2. All remaining memory modules on Processor card 1 |

Service provider information

|      |      |      |                                                                                                                      |
|------|------|------|----------------------------------------------------------------------------------------------------------------------|
|      |      |      | 3. Processor card 1                                                                                                  |
| 0052 | 0003 | 00A2 | 1. Memory module 7 on Processor card 1<br>2. All remaining memory modules on Processor card 1<br>3. Processor card 1 |
| 0052 | 0003 | 00A4 | 1. Memory module 1 on Processor card 1<br>2. All remaining memory modules on Processor card 1<br>3. Processor card 1 |
| 0052 | 0003 | 00A6 | 1. Memory module 2 on Processor card 1<br>2. All remaining memory modules on Processor card 1<br>3. Processor card 1 |
| 0052 | 0003 | 00A8 | 1. Memory module 6 on Processor card 1<br>2. All remaining memory modules on Processor card 1<br>3. Processor card 1 |
| 0052 | 0003 | 00AA | 1. Memory module 5 on Processor card 1<br>2. All remaining memory modules on Processor card 1<br>3. Processor card 1 |
| 0052 | 0003 | 00AC | 1. Memory module 3 on Processor card 1<br>2. All remaining memory modules on Processor card 1<br>3. Processor card 1 |
| 0052 | 0003 | 00AE | 1. Memory module 4 on Processor card 1<br>2. All remaining memory modules on Processor card 1<br>3. Processor card 1 |
| 0052 | 0003 | 00C0 | 1. All memory modules (1-8) on processor card 1<br>2. Processor card 1                                               |
| 0052 | 0004 | 0092 | 1. All memory modules (1-8) on processor card 2<br>2. Processor card 2                                               |
| 0052 | 0004 | 00A0 | 1. Memory module 8 on Processor card 2<br>2. All remaining memory modules on Processor card 2<br>3. Processor card 2 |
| 0052 | 0004 | 00A2 | 1. Memory module 7 on Processor card 2<br>2. All remaining memory modules on Processor card 2<br>3. Processor card 2 |
| 0052 | 0004 | 00A4 | 1. Memory module 1 on Processor card 2<br>2. All remaining memory modules on Processor card 2<br>3. Processor card 2 |
| 0052 | 0004 | 00A6 | 1. Memory module 2 on Processor card 2<br>2. All remaining memory modules on Processor card 2                        |

Service provider information

|      |      |      |                                                                                                                      |
|------|------|------|----------------------------------------------------------------------------------------------------------------------|
|      |      |      | 3. Processor card 2                                                                                                  |
| 0052 | 0004 | 00A8 | 1. Memory module 6 on Processor card 2<br>2. All remaining memory modules on Processor card 2<br>3. Processor card 2 |
| 0052 | 0004 | 00AA | 1. Memory module 5 on Processor card 2<br>2. All remaining memory modules on Processor card 2<br>3. Processor card 2 |
| 0052 | 0004 | 00AC | 1. Memory module 3 on Processor card 2<br>2. All remaining memory modules on Processor card 2<br>3. Processor card 2 |
| 0052 | 0004 | 00AE | 1. Memory module 4 on Processor card 2<br>2. All remaining memory modules on Processor card 2<br>3. Processor card 2 |
| 0052 | 0004 | 00C0 | 1. All memory modules (1-8) on processor card 2<br>2. Processor card 2                                               |
| 0052 | 0005 | 00A0 | 1. RIO/HSL adapter card                                                                                              |
|      |      | 00C0 |                                                                                                                      |
| 0052 | 0006 | 00C0 | 1. Service processor card (if present in target enclosure)<br>2. I/O backplane                                       |
| 0052 | 0007 | 0040 | 1. Disk drive backplane                                                                                              |
|      |      | 0044 |                                                                                                                      |
|      |      | 00A0 |                                                                                                                      |
|      |      | 00A4 |                                                                                                                      |
|      |      | 00C0 |                                                                                                                      |
| 0052 | 0008 | 00A0 | 1. Media drive backplane<br>2. Disk drive backplane                                                                  |
| 0052 | 0009 | 00A0 | 1. Regulator distribution connection backplane                                                                       |
| 0052 | 000A | 00A0 |                                                                                                                      |
| 0052 | 000B | 00C0 | 1. Service processor card (if present in target enclosure)<br>2. I/O backplane                                       |
| 0052 | 000C | 00C0 | 1. Disk drive backplane                                                                                              |
| 0052 | 000F | 00C0 | 1. Service processor card (if present in target enclosure)<br>2. I/O backplane                                       |
| 00FF | 00FF | 00A0 | 1. Control panel<br>2. Disk drive backplane                                                                          |
| 00FF | 00FF | 00A8 | 1. Service processor card (if present in target enclosure)                                                           |
|      |      | 00C0 |                                                                                                                      |



## FSPSP41: Models ESCALA PL 3250R or ESCALA PL 6450R

Use this procedure to help you isolate a problem that occurred when trying to access a chip on the I2C bus on models ESCALA PL 3250R or ESCALA PL 6450R.

1. Record words 3, 7, and 8 of the primary system reference code (SRC) from the error log.
2. Determine which service processor initiated the I2C operation by using the last byte in word 3 of the primary SRC:
  - ◆ When the last byte in word 3 of the primary SRC is a 10, then service processor 0 initiated the I2C
  - ◆ When the last byte in word 3 of the primary SRC is a 20, then the service processor 1 initiated the I2C
  - ◆ If the last byte is a 30, use one of the following methods to determine the enclosure:

If you have access to the Advanced System Management Interface (ASMI), log on and display the details of the service processor error log. Using the Platform Event Log id (shown in the first table of each detail of the log), look at the first byte.

◇ If the first byte is a 50, then service processor 0 started the I2C.

◇ If the first byte is a 51, then service processor 1 started the I2C.

If you have access to an Hardware Management Console (HMC), log in as PE user and bring up Manage Serviceable Events under the Service Focal Point screen. Display the events for the corresponding service processor system, then double-click the system to see the details. Look at the Field Platform log ID, which contains a decimal value that you need to convert to a hexadecimal value.

◇ If the first byte of the hexadecimal value is a 50, then service processor 0 started the I2C.

◇ If the first byte of the hexadecimal value is a 51, then service processor 1 started the I2C.

**Note:** The following I2C FRU table refers to the service processor identified in this step as the *originating service processor*.

3. Determine which parts you need to replace.
  - a. Using the following I2C FRU table for models ESCALA PL 3250R and ESCALA PL 6450R, refer to words 7 and 8 of the primary SRC to locate the I2C FRU list. The I2C FRU list identifies the parts that you need to replace. Click the following link to display the I2C FRU table: [I2C FRU table for models ESCALA PL 3250R or ESCALA PL 6450R](#)
  - b. Did you find the I2C FRU list?
    - ◇ **Yes:** Continue with the next step.
    - ◇ **No:** Contact your next level of support. **This ends the procedure.**
4. Starting with the first FRU in the list that you located in the table, perform the following:
  - a. Power off the system.
  - b. Replace the FRU. Go to [Finding part locations](#) for location, part number, and exchange information.
  - c. Perform a reset of the service processor from ASMI. Refer to [Rebooting the service processor](#).
  - d. Go to [Perform a slow boot](#), then continue with the next step.
  - e. Is the problem resolved?
    - ◇ **Yes:** This ends the procedure.
    - ◇ **No:** Continue with the next step.
5. Have you replaced all of the FRUs in the list?
  - ◆ **Yes:** Contact your next level of support. This ends the procedure.
  - ◆ **No:** Repeat step 4 for the next FRU in the list.

Table 1. I2C FRU table for models ESCALA PL 3250R or ESCALA PL 6450R

| Word 7 | Word 8 | I2C FRU list |
|--------|--------|--------------|
|--------|--------|--------------|

## Service provider information

| Leftmost 2 bytes | Rightmost 2 bytes | Leftmost 2 bytes | Rightmost 2 bytes |                                                                                                                                                                                                                            |
|------------------|-------------------|------------------|-------------------|----------------------------------------------------------------------------------------------------------------------------------------------------------------------------------------------------------------------------|
| 0002             | 0000              | 0000             | 00C6              | <ol style="list-style-type: none"> <li>1. Light strips, front and back</li> <li>2. Cables to light strips</li> <li>3. Originating service processor</li> </ol>                                                             |
| 0002             | 00FF              | 00FF             | 00A8              | <ol style="list-style-type: none"> <li>1. Originating service processor</li> </ol>                                                                                                                                         |
| 0004             | 0052              | 0008             | 00A8              | <ol style="list-style-type: none"> <li>1. Adapter card 1 for node 3</li> <li>2. Multiplexer card for node 3</li> <li>3. Node 3 backplane</li> <li>4. Originating service processor</li> <li>5. System backplane</li> </ol> |
| 0004             | 0052              | 0009             | 00A8              | <ol style="list-style-type: none"> <li>1. Adapter card 2 for node 3</li> <li>2. Multiplexer card for node 3</li> <li>3. Node 3 backplane</li> <li>4. Originating service processor</li> <li>5. System backplane</li> </ol> |
| 0004             | 0052              | 000A             | 00A8              | <ol style="list-style-type: none"> <li>1. Adapter card 3 for node 3</li> <li>2. Multiplexer card for node 3</li> <li>3. Node 3 backplane</li> <li>4. Originating service processor</li> <li>5. System backplane</li> </ol> |
| 0004             | 0052              | 000B             | 00A8              | <ol style="list-style-type: none"> <li>1. Adapter card 4 for node 3</li> <li>2. Multiplexer card for node 3</li> <li>3. Node 3 backplane</li> <li>4. Originating service processor</li> <li>5. System backplane</li> </ol> |
| 0004             | 0052              | 000C             | 00A8              | <ol style="list-style-type: none"> <li>1. Adapter card 5 for node 3</li> <li>2. Multiplexer card for node 3</li> <li>3. Node 3 backplane</li> <li>4. Originating service processor</li> <li>5. System backplane</li> </ol> |
| 0004             | 0052              | 000D             | 00A8              | <ol style="list-style-type: none"> <li>1. Adapter card 6 for node 3</li> <li>2. Multiplexer card for node 3</li> <li>3. Node 3 backplane</li> <li>4. Originating service processor</li> <li>5. System backplane</li> </ol> |
| 0004             | 0052              | 000E             | 00A8              | <ol style="list-style-type: none"> <li>1. Adapter card 7 for node 3</li> <li>2. Multiplexer card for node 3</li> <li>3. Node 3 backplane</li> <li>4. Originating service processor</li> <li>5. System backplane</li> </ol> |
| 0004             | 0052              | 000F             | 00A8              | <ol style="list-style-type: none"> <li>1. Adapter card 8 for node 3</li> <li>2. Multiplexer card for node 3</li> <li>3. Node 3 backplane</li> <li>4. Originating service processor</li> <li>5. System backplane</li> </ol> |
| 0005             | 0052              | 0008             | 00A8              | <ol style="list-style-type: none"> <li>1. Adapter card 1 for node 2</li> <li>2. Multiplexer card for node 2</li> <li>3. Node 2 backplane</li> <li>4. Originating service processor</li> <li>5. System backplane</li> </ol> |

Service provider information

|      |      |      |      |                                                                                                                                                                                                                            |
|------|------|------|------|----------------------------------------------------------------------------------------------------------------------------------------------------------------------------------------------------------------------------|
| 0005 | 0052 | 0009 | 00A8 | <ol style="list-style-type: none"> <li>1. Adapter card 2 for node 2</li> <li>2. Multiplexer card for node 2</li> <li>3. Node 2 backplane</li> <li>4. Originating service processor</li> <li>5. System backplane</li> </ol> |
| 0005 | 0052 | 000A | 00A8 | <ol style="list-style-type: none"> <li>1. Adapter card 3 for node 2</li> <li>2. Multiplexer card for node 2</li> <li>3. Node 2 backplane</li> <li>4. Originating service processor</li> <li>5. System backplane</li> </ol> |
| 0005 | 0052 | 000B | 00A8 | <ol style="list-style-type: none"> <li>1. Adapter card 4 for node 2</li> <li>2. Multiplexer card for node 2</li> <li>3. Node 2 backplane</li> <li>4. Originating service processor</li> <li>5. System backplane</li> </ol> |
| 0005 | 0052 | 000C | 00A8 | <ol style="list-style-type: none"> <li>1. Adapter card 5 for node 2</li> <li>2. Multiplexer card for node 2</li> <li>3. Node 2 backplane</li> <li>4. Originating service processor</li> <li>5. System backplane</li> </ol> |
| 0005 | 0052 | 000D | 00A8 | <ol style="list-style-type: none"> <li>1. Adapter card 6 for node 2</li> <li>2. Multiplexer card for node 2</li> <li>3. Node 2 backplane</li> <li>4. Originating service processor</li> <li>5. System backplane</li> </ol> |
| 0005 | 0052 | 000E | 00A8 | <ol style="list-style-type: none"> <li>1. Adapter card 7 for node 2</li> <li>2. Multiplexer card for node 2</li> <li>3. Node 2 backplane</li> <li>4. Originating service processor</li> <li>5. System backplane</li> </ol> |
| 0005 | 0052 | 000F | 00A8 | <ol style="list-style-type: none"> <li>1. Adapter card 8 for node 2</li> <li>2. Multiplexer card for node 2</li> <li>3. Node 2 backplane</li> <li>4. Originating service processor</li> <li>5. System backplane</li> </ol> |
| 0006 | 0052 | 0008 | 00A8 | <ol style="list-style-type: none"> <li>1. Adapter card 1 for node 1</li> <li>2. Multiplexer card for node 1</li> <li>3. Node 1 backplane</li> <li>4. Originating service processor</li> <li>5. System backplane</li> </ol> |
|      |      |      | 00C6 |                                                                                                                                                                                                                            |
|      |      |      | 0040 |                                                                                                                                                                                                                            |
| 0006 | 0052 | 0009 | 00A8 | <ol style="list-style-type: none"> <li>1. Adapter card 2 for node 1</li> <li>2. Multiplexer card for node 1</li> <li>3. Node 1 backplane</li> <li>4. Originating service processor</li> <li>5. System backplane</li> </ol> |
|      |      |      | 00C6 |                                                                                                                                                                                                                            |
|      |      |      | 0040 |                                                                                                                                                                                                                            |
| 0006 | 0052 | 000A | 00A8 | <ol style="list-style-type: none"> <li>1. Adapter card 3 for node 1</li> <li>2. Multiplexer card for node 1</li> <li>3. Node 1 backplane</li> <li>4. Originating service processor</li> <li>5. System backplane</li> </ol> |
|      |      |      | 00C6 |                                                                                                                                                                                                                            |
|      |      |      | 0040 |                                                                                                                                                                                                                            |
| 0006 | 0052 | 000B | 00A8 | <ol style="list-style-type: none"> <li>1. Adapter card 4 for node 1</li> <li>2. Multiplexer card for node 1</li> <li>3. Node 1 backplane</li> </ol>                                                                        |
|      |      |      | 00C6 |                                                                                                                                                                                                                            |
|      |      |      | 0040 |                                                                                                                                                                                                                            |

Service provider information

|      |      |      |      |                                                                                                                                                  |
|------|------|------|------|--------------------------------------------------------------------------------------------------------------------------------------------------|
|      |      |      |      | 4. Originating service processor<br>5. System backplane                                                                                          |
| 0006 | 0052 | 000C | 00A8 | 1. Adapter card 5 for node 1<br>2. Multiplexer card for node 1<br>3. Node 1 backplane<br>4. Originating service processor<br>5. System backplane |
|      |      |      | 00C6 |                                                                                                                                                  |
|      |      |      | 0040 |                                                                                                                                                  |
| 0006 | 0052 | 000D | 00A8 | 1. Adapter card 6 for node 1<br>2. Multiplexer card for node 1<br>3. Node 1 backplane<br>4. Originating service processor<br>5. System backplane |
|      |      |      | 00C6 |                                                                                                                                                  |
|      |      |      | 0040 |                                                                                                                                                  |
| 0006 | 0052 | 000E | 00A8 | 1. Adapter card 7 for node 1<br>2. Multiplexer card for node 1<br>3. Node 1 backplane<br>4. Originating service processor<br>5. System backplane |
|      |      |      | 00C6 |                                                                                                                                                  |
|      |      |      | 0040 |                                                                                                                                                  |
| 0006 | 0052 | 000F | 00A8 | 1. Adapter card 8 for node 1<br>2. Multiplexer card for node 1<br>3. Node 1 backplane<br>4. Originating service processor<br>5. System backplane |
|      |      |      | 00C6 |                                                                                                                                                  |
|      |      |      | 0040 |                                                                                                                                                  |
| 000B | 0052 | 0008 | 00A8 | 1. Adapter card 1 for node 0<br>2. Multiplexer card for node 0<br>3. Node 0 backplane<br>4. Originating service processor<br>5. System backplane |
|      |      |      | 00C6 |                                                                                                                                                  |
|      |      |      | 0040 |                                                                                                                                                  |
| 000B | 0052 | 0009 | 00A8 | 1. Adapter card 2 for node 0<br>2. Multiplexer card for node 0<br>3. Node 0 backplane<br>4. Originating service processor<br>5. System backplane |
|      |      |      | 00C6 |                                                                                                                                                  |
|      |      |      | 0040 |                                                                                                                                                  |
| 000B | 0052 | 000A | 00A8 | 1. Adapter card 3 for node 0<br>2. Multiplexer card for node 0<br>3. Node 0 backplane<br>4. Originating service processor<br>5. System backplane |
|      |      |      | 00C6 |                                                                                                                                                  |
|      |      |      | 0040 |                                                                                                                                                  |
| 000B | 0052 | 000B | 00A8 | 1. Adapter card 4 for node 0<br>2. Multiplexer card for node 0<br>3. Node 0 backplane<br>4. Originating service processor<br>5. System backplane |
|      |      |      | 00C6 |                                                                                                                                                  |
|      |      |      | 0040 |                                                                                                                                                  |
| 000B | 0052 | 000C | 00A8 | 1. Adapter card 5 for node 0<br>2. Multiplexer card for node 0<br>3. Node 0 backplane<br>4. Originating service processor<br>5. System backplane |
|      |      |      | 00C6 |                                                                                                                                                  |
|      |      |      | 0040 |                                                                                                                                                  |
| 000B | 0052 | 000D | 00A8 | 1. Adapter card 6 for node 0<br>2. Multiplexer card for node 0<br>3. Node 0 backplane<br>4. Originating service processor<br>5. System backplane |
|      |      |      | 00C6 |                                                                                                                                                  |
|      |      |      | 0040 |                                                                                                                                                  |

Service provider information

|      |      |      |      |                                                                                                                                                                                                                            |
|------|------|------|------|----------------------------------------------------------------------------------------------------------------------------------------------------------------------------------------------------------------------------|
| 000B | 0052 | 000E | 00A8 | <ol style="list-style-type: none"> <li>1. Adapter card 7 for node 0</li> <li>2. Multiplexer card for node 0</li> <li>3. Node 0 backplane</li> <li>4. Originating service processor</li> <li>5. System backplane</li> </ol> |
|      |      |      | 00C6 |                                                                                                                                                                                                                            |
|      |      |      | 0040 |                                                                                                                                                                                                                            |
| 000B | 0052 | 000F | 00A8 | <ol style="list-style-type: none"> <li>1. Adapter card 8 for node 0</li> <li>2. Multiplexer card for node 0</li> <li>3. Node 0 backplane</li> <li>4. Originating service processor</li> <li>5. System backplane</li> </ol> |
|      |      |      | 00C6 |                                                                                                                                                                                                                            |
|      |      |      | 0040 |                                                                                                                                                                                                                            |
| 000C | 0052 | 0001 | 00A8 | <ol style="list-style-type: none"> <li>1. Other service processor</li> <li>2. Originating service processor</li> <li>3. System backplane</li> </ol>                                                                        |
| 000C | 0052 | 0003 | 00A8 | <ol style="list-style-type: none"> <li>1. Oscillator 2</li> <li>2. Originating service processor</li> <li>3. System backplane</li> </ol>                                                                                   |
| 000C | 0052 | 0004 | 00A8 | <ol style="list-style-type: none"> <li>1. Oscillator 1</li> <li>2. Originating service processor</li> <li>3. System backplane</li> </ol>                                                                                   |
| 000C | 0052 | 0005 | 00A8 | <ol style="list-style-type: none"> <li>1. Light strip, front</li> <li>2. Originating service processor</li> </ol>                                                                                                          |
| 000C | 0052 | 0006 | 00A8 | <ol style="list-style-type: none"> <li>1. Light strip, back</li> <li>2. Originating service processor</li> </ol>                                                                                                           |
| 000C | 0052 | 0007 | 00A8 | <ol style="list-style-type: none"> <li>1. Node 0 backplane</li> <li>2. Originating service processor</li> <li>3. System backplane</li> </ol>                                                                               |
| 000C | 0052 | 0008 | 00A8 | <ol style="list-style-type: none"> <li>1. Node 1 backplane</li> <li>2. Originating service processor</li> <li>3. System backplane</li> </ol>                                                                               |
| 000C | 0052 | 0009 | 00A8 | <ol style="list-style-type: none"> <li>1. Node 2 backplane</li> <li>2. Originating service processor</li> <li>3. System backplane</li> </ol>                                                                               |
| 000C | 0052 | 000A | 00A8 | <ol style="list-style-type: none"> <li>1. Node 3 backplane</li> <li>2. Originating service processor</li> <li>3. System backplane</li> </ol>                                                                               |
| 000C | 0052 | 000B | 00A8 | <ol style="list-style-type: none"> <li>1. Multiplexer card for node 0</li> <li>2. Node 0 backplane</li> <li>3. Originating service processor</li> <li>4. System backplane</li> </ol>                                       |
|      |      |      | 00C6 |                                                                                                                                                                                                                            |
|      |      |      | 00C8 |                                                                                                                                                                                                                            |
| 000C | 0052 | 000C | 00A8 | <ol style="list-style-type: none"> <li>1. Multiplexer card for node 1</li> <li>2. Node 1 backplane</li> <li>3. Originating service processor</li> <li>4. System backplane</li> </ol>                                       |
|      |      |      | 00C6 |                                                                                                                                                                                                                            |
|      |      |      | 00C8 |                                                                                                                                                                                                                            |
| 000C | 0052 | 000D | 00A8 | <ol style="list-style-type: none"> <li>1. Multiplexer card for node 2</li> <li>2. Node 2 backplane</li> <li>3. Originating service processor</li> <li>4. System backplane</li> </ol>                                       |
|      |      |      | 00C6 |                                                                                                                                                                                                                            |
|      |      |      | 00C8 |                                                                                                                                                                                                                            |
| 000C | 0052 | 000E | 00A8 |                                                                                                                                                                                                                            |

Service provider information

|      |      |      |      |                                                                                                                  |
|------|------|------|------|------------------------------------------------------------------------------------------------------------------|
|      |      |      | 00C6 | 1. Multiplexer card for node 3<br>2. Node 3 backplane<br>3. Originating service processor<br>4. System backplane |
|      |      |      | 00C8 |                                                                                                                  |
| 000C | 0052 | 0011 | 00A8 | 1. Originating service processor<br>2. System backplane                                                          |
|      |      | 0012 |      |                                                                                                                  |
| 000C | 0052 | 0014 | 00A8 | 1. Node 0 backplane<br>2. Originating service processor<br>3. System backplane                                   |
| 000C | 0052 | 0015 | 00A8 | 1. Node 1 backplane<br>2. Originating service processor<br>3. System backplane                                   |
| 000C | 0052 | 0016 | 00A8 | 1. Node 2 backplane<br>2. Originating service processor<br>3. System backplane                                   |
| 000C | 0052 | 0017 | 00A8 | 1. Node 3 backplane<br>2. Originating service processor<br>3. System backplane                                   |

## FSPSP42

An error communicating between two system processors was detected.

If you were unable to correct the problem by following FRUs that were previously specified before coming to this procedure, consider the possibility of failing node backplanes.

Use the following procedure for the model on which you are working:

- [Models ESCALA PL 250R-L, ESCALA PL 250T/R, ESCALA PL 450T/R, ,](#)
- [Model ESCALA PL 850R/PL 1650R/R+](#)
- [Models ESCALA PL 3250R or ESCALA PL 6450R](#)

### Parent topic: [Service processor isolation procedures](#)

**Models ESCALA PL 250R-L, ESCALA PL 250T/R, ESCALA PL 450T/R, ,**

1. Power off the system (see [Powering on and powering off](#)).
2. Replace the bad node backplane or backplanes by using [NODEPL](#).
3. Perform a slow boot. This ends the procedure.

**Model ESCALA PL 850R/PL 1650R/R+**

1. Use FRUs that were previously specified to determine if the system processors are on separate nodes. Are the system processors on separate nodes?
  - ◆ No: Continue with to step 2.
  - ◆ Yes: Do the following:
    - a. Power off the system (see [Powering on and powering off](#)).
    - b. Replace the SMP cables between the two nodes.
    - c. [Perform a slow boot](#).
    - d. Is the problem resolved?

- Yes: This ends the procedure.
  - No: Continue to step 2.
2. Power off the system (see [Powering on and powering off](#)).
  3. Replace the bad node backplane or backplanes by using [NODEPL](#).
  4. [Perform a slow boot](#). This ends the procedure.

#### Models ESCALA PL 3250R or ESCALA PL 6450R

1. Use FRUs that were previously specified to determine if the system processors are on separate nodes. Are the system processors on separate nodes?
  - ◆ No: Continue with step 2.
  - ◆ Yes: Do the following:
    - a. Power off the system (see [Powering on and powering off](#)).
    - b. Replace the bad node backplane or backplanes by using [NODEPL](#).
    - c. [Perform a slow boot](#).
    - d. Is the problem resolved?
      - Yes: This ends the procedure.
      - No: Replace the bad node backplane or backplanes by using [SYSBKPL](#). This ends the procedure.
2. Power off the system (see [Powering on and powering off](#)).
3. Replace the bad node backplane or backplanes by using [NODEPL](#).
4. [Perform a slow boot](#). This ends the procedure.

## FSPSP43

Use this procedure when you are performing a cold service processor replacement and the system uses static IP addressing for Advanced System Management Interface (ASMI) and Hardware Management Console (HMC) network connections.

1. Does the system use static IP addressing?
  - ◆ **Yes:** Continue with the next step.
  - ◆ **No: This ends the procedure.**
2. Configure the network interfaces by using static IP addresses. (See [Configuring network interfaces](#).)
3. Remove AC line power from both drawers that contain the service processors.
4. Plug in the AC line power for the drawer that contains the original service processor (the one you are not replacing).
5. Wait for the original service processor to come to Power On Standby.
6. Plug in the AC line power for the drawer that contains the new service processor.
7. Return to the HMC Repair and Verify flows to indicate that power has been applied to the new service processor. (For more information, see [Verifying the repair from the HMC](#)) **This ends the procedure.**

**Parent topic:** [Service processor isolation procedures](#)

## FSPSP44

A problem occurred while trying to read from or write to a smartchip FRU.

1. Are you working on a model ESCALA PL 3250R, PL 3250R+, ESCALA PL 6450 or PL 6450R+?
  - ◆ **Yes:** Continue with the next step.
  - ◆ **No: This ends the procedure.**
2. Record word 6 from the primary system reference code (SRC) of the error log.
3. Replace the multiplexer card. Using [Table 1](#), find word 6 of the SRC that you recorded, and replace the multiplexer card associated with the specified node. **This ends the procedure.**

Table 1. Values for word 6 and associated multiplexer nodes

| Word 6     | Node for the multiplexer card to be replaced |
|------------|----------------------------------------------|
| 1000, 1001 | Node 0                                       |
| 1002, 1003 | Node 1                                       |

|                   |        |
|-------------------|--------|
| 1004, 1005        | Node 2 |
| 1006, 1007        | Node 3 |
| D000 through D00F | Node 0 |
| D010 through D01F | Node 1 |
| D020 through D02F | Node 2 |
| D030 through D03F | Node 3 |

Parent topic: [Service processor isolation procedures](#)

---

## FSPSPC1

If the system hangs after the code that sent you to this procedure appears in the control panel, perform these steps to reset the service processor.

Use the procedure that applies to the system on which you are working:

- [Systems with a physical control panel](#)
- [Systems with a logical control panel](#)

### Resetting the service processor on systems with a physical control panel

1. If the Advanced System Management Interface (ASMI) is available, reset the service processor using the ASMI menus.

Were you able to use the ASMI menus to reset the service processor?

◆ **Yes: This ends the procedure.**

◆ **No:** Continue with the next step.

2. Activate the service processor pinhole reset switch on the system's operator panel by carefully performing these steps:
  - a. Using an insulated paper clip, unbend the clip so that it has a straight section about two inches long.
  - b. Insert the clip straight into the hole, keeping the clip perpendicular to the plastic bezel.
  - c. When you engage the reset switch, you should feel the detent of the switch.
  - d. Pressing the reset switch resets the service processor and causes the system to shut down.
3. Reboot the system in slow mode from the permanent side using control panel function 02 or the ASMI menus, if available.
4. If the hang repeats, check with service support to see if a firmware update is available that fixes the problem. For more information, see [Getting fixes](#).
5. Choose from the following options:
  - ◆ If no firmware update is available, continue with the next step.
  - ◆ If a firmware update is available, apply it using the Service Focal Point in the Hardware Management Console (HMC).

Did the update resolve the problem so that the system now boots?

◇ **Yes: This ends the procedure.**

◇ **No:** You are here because there is no HMC attached to the system, the flash update failed, or the updated firmware did not fix the hang. Continue with the next step.

6. Choose from the following options:
  - ◆ If you are a customer, and your system has only one service processor, contact your hardware service provider. **This ends the procedure.**
  - ◆ If you are a customer, and your system has a secondary service processor, use the HMC to initiate a [service processor failover](#) and continue to bring up the system. Contact your service provider to schedule deferred maintenance on the service processor that is hung. **This ends the procedure.**
  - ◆ If you are a hardware service provider, continue with the next step.
7. Replace the service processor (see symbolic FRU [SVCPROC](#)).



8. If replacing the service processor does not fix the problem, contact your next level of support. **This ends the procedure.**

### Resetting the service processor on systems with a logical control panel

1. Reset the service processor:
  - ◆ On model 5/75, use the Advanced System Management Interface (ASMI) menus, if available, or the Hardware Management Console (HMC) first to remove then to reapply power to the processor node.
  - ◆ On models ESCALA PL 3250R or ESCALA PL 6450R, use the ASMI menus, if available, or the UEPO switch first to remove then to reapply power to the system.
2. Using the setting in the ASMI menu, reboot the system in slow mode from the permanent side.
3. If the hang repeats, check with service support to see if a firmware update is available that fixes the problem. See [Getting fixes](#) in the Customer service and support topic for details.
4. Choose from the following options:
  - ◆ If no firmware update is available, continue with the next step.
  - ◆ If a firmware update is available, apply it using the Service Focal Point in the HMC.

Did the update resolve the problem so that the system now boots?

- ◇ **Yes: This ends the procedure.**
  - ◇ **No:** You are here because there is no HMC attached to the system, the flash update failed, or the updated firmware did not fix the hang. Continue with the next step.
5. Choose from the following options:
    - ◆ If you are a customer, and your system has only one service processor, contact your hardware service provider. **This ends the procedure.**
    - ◆ If you are a customer, and your system has a secondary service processor, use the HMC to initiate a [service processor failover](#) and continue to bring up the system. Contact your service provider to schedule deferred maintenance on the service processor that is hung. **This ends the procedure.**
    - ◆ If you are a hardware service provider, continue with the next step.
  6. Replace the service processor (see symbolic FRU [SVCPROC](#)).
  7. If replacing the service processor does not fix the problem, contact your next level of support. **This ends the procedure.**

Parent topic: [Service processor isolation procedures](#)

---

## FSPSPD1

If the system hangs after the code that sent you to this procedure appears in the control panel, perform these steps to reset the service processor.

Use the procedure that applies to the system on which you are working:

- [Systems with a physical control panel](#)
- [Systems with a logical control panel](#)

### Resetting the service processor on systems with a physical control panel

1. If the Advanced System Management Interface (ASMI) is available, reset the service processor using the ASMI menus.

Were you able to use the ASMI menus to reset the service processor?

- ◆ **Yes: This ends the procedure.**
  - ◆ **No:** Continue with the next step.
2. Activate the service processor pinhole reset switch on the system's operator panel by carefully performing these steps:
    - a. Using an insulated paper clip, unbend the clip so that it has a straight section about two inches long.
    - b. Insert the clip straight into the hole, keeping the clip perpendicular to the plastic bezel.

- c. When you engage the reset switch, you should feel the detent of the switch.
- d. Pressing the reset switch resets the service processor and causes the system to shut down.
3. Reboot the system in slow mode from the permanent side using control panel function 02 or the ASMI menus, if available.
4. If the hang repeats, check with service support to see if a firmware update is available that fixes the problem. For more information, see [Getting fixes](#).
5. Choose from the following options:
  - ◆ If no firmware update is available, continue with the next step.
  - ◆ If a firmware update is available, apply it using the Service Focal Point in the Hardware Management Console (HMC).

Did the update resolve the problem so that the system now boots?

◇ **Yes: This ends the procedure.**

◇ **No:** You are here because there is no HMC attached to the system, the flash update failed, or the updated firmware did not fix the hang. Continue with the next step.

6. Choose from the following options:
  - ◆ If you are a customer, and your system has only one service processor, contact your hardware service provider. **This ends the procedure.**
  - ◆ If you are a customer, and your system has a secondary service processor, use the HMC to initiate a [service processor failover](#) and continue to bring up the system. Contact your service provider to schedule deferred maintenance on the service processor that is hung. **This ends the procedure.**
  - ◆ If you are a hardware service provider, continue with the next step.
7. Replace the service processor (see symbolic FRU [SVCPROC](#)).
8. If replacing the service processor does not fix the problem, contact your next level of support. **This ends the procedure.**

### Resetting the service processor on systems with a logical control panel

1. Reset the service processor:
  - ◆ On model 5/75, use the Advanced System Management Interface (ASMI) menus, if available, or the Hardware Management Console (HMC) first to remove then to reapply power to the processor node.
  - ◆ On models ESCALA PL 3250R or ESCALA PL 6450R, use the ASMI menus, if available, or the UEPO switch first to remove then to reapply power to the system.
2. Using the setting in the ASMI menu, reboot the system in slow mode from the permanent side.
3. If the hang repeats, check with service support to see if a firmware update is available that fixes the problem. See [Getting fixes](#) in the Customer service and support topic for details.
4. Choose from the following options:
  - ◆ If no firmware update is available, continue with the next step.
  - ◆ If a firmware update is available, apply it using the Service Focal Point in the HMC.

Did the update resolve the problem so that the system now boots?

◇ **Yes: This ends the procedure.**

◇ **No:** You are here because there is no HMC attached to the system, the flash update failed, or the updated firmware did not fix the hang. Continue with the next step.

5. Choose from the following options:
  - ◆ If you are a customer, and your system has only one service processor, contact your hardware service provider. **This ends the procedure.**
  - ◆ If you are a customer, and your system has a secondary service processor, use the HMC to initiate a [service processor failover](#) and continue to bring up the system. Contact your service provider to schedule deferred maintenance on the service processor that is hung. **This ends the procedure.**
  - ◆ If you are a hardware service provider, continue with the next step.
6. Replace the service processor (see symbolic FRU [SVCPROC](#)).
7. If replacing the service processor does not fix the problem, contact your next level of support. **This ends the procedure.**

Parent topic: [Service processor isolation procedures](#)

---

## Tape unit isolation procedures

This topic contains the procedures necessary to isolate a failure in a tape device.

In these procedures, the term *tape unit* may be any one of the following:

- An internal tape drive, including its electronic parts and status indicators
- An internal tape drive, including its tray, power regulator, and AMDs
- An external tape drive, including its power supply, power switch, power regulator, and AMDs

You should interpret the term *tape unit* to mean the tape drive you are working on. However, these procedures use the terms *tape drive* and *enclosure* to indicate a more specific meaning.

Read and observe all safety procedures before servicing the system and while performing the procedures in this topic. Unless instructed otherwise, always power off the system or expansion unit where the FRU is located (see [Powering on and powering off](#)) before removing, exchanging, or installing a field-replaceable unit (FRU).

### **DANGER**When working on or around the system, observe the following precautions:

Electrical voltage and current from power, telephone, and communication cables are hazardous. To avoid a shock hazard:

- Connect power to this unit only with the provided power cord. Do not use the provided power cord for any other product.
- Do not open or service any power supply assembly.
- Do not connect or disconnect any cables or perform installation, maintenance, or reconfiguration of this product during an electrical storm.
- The product might be equipped with multiple power cords. To remove all hazardous voltages, disconnect all power cords.
- Connect all power cords to a properly wired and grounded electrical outlet. Ensure that the outlet supplies proper voltage and phase rotation according to the system rating plate.
- Connect any equipment that will be attached to this product to properly wired outlets.
- When possible, use one hand only to connect or disconnect signal cables.
- Never turn on any equipment when there is evidence of fire, water, or structural damage.
- Disconnect the attached power cords, telecommunications systems, networks, and modems before you open the device covers, unless instructed otherwise in the installation and configuration procedures.
- Connect and disconnect cables as described in the following procedures when installing, moving, or opening covers on this product or attached devices.  
To Disconnect:
  1. Turn off everything (unless instructed otherwise).
  2. Remove the power cords from the outlets.
  3. Remove the signal cables from the connectors.
  4. Remove all cables from the devices

To Connect:

1. Turn off everything (unless instructed otherwise).
2. Attach all cables to the devices.
3. Attach the signal cables to the connectors.
4. Attach the power cords to the outlets.
5. Turn on the devices.

(D005)

- **TUPIP02**  
Use this procedure to perform the 8mm tape drive read self-test and hardware self-test.
- **TUPIP03**  
You were directed here because you may need to exchange a failing part.
- **TUPIP04**  
Use this procedure to reset an IOP and its attached tape units. Read the (overview) before continuing with this procedure.

- **TUPIP06**

Use this procedure to isolate a Device Not Found message during installation from an alternate device.

- **Tape unit self-test procedure**

This procedure is designed to allow you to quickly perform a complete set of diagnostic tests on a 6384 or 6387 tape unit.

- **Tape device ready conditions**

All the conditions that are listed for the device, must be correct for the device to be ready.

Parent topic: [Isolation procedures](#)

---

## TUPIP02

Use this procedure to perform the 8mm tape drive read self-test and hardware self-test.

The write test is performed in [TUPIP03](#).

1. If the system has logical partitions, perform this procedure from the logical partition that reported the problem (see [Determining if the system has logical partitions](#)).
2. Press the Unload switch on the front of the 8mm tape drive. Is a data cartridge present?
  - ◆ No: Continue with the next step.
  - ◆ Yes: Attempt to remove the data cartridge. Can you remove the data cartridge?
    - ◇ Yes: Continue with the next step.
    - ◇ No: The tape drive is the failing part. Go to (Tape cartridge - Manual removal). After removing the data cartridge, exchange the tape drive (see [Removing and replacing parts](#)). This ends the procedure.
3. Clean the tape drive by using the cleaning cartridge (part 16G8467). If the tape drive ejects the cleaning cartridge with the Disturbance light on, a new cleaning cartridge is needed. The tape drive unloads automatically when cleaning is complete. Cleaning takes up to 5 minutes.

Is the Disturbance light on continuously?

- ◆ No: Continue with the next step.
  - ◆ Yes: Repeat this step while using a new cleaning cartridge. If you are using a new cleaning cartridge and the Disturbance light does not go off, the possible failing part is the 8mm tape drive. Go to [TUPIP03](#). This ends the procedure.
4. Is the Disturbance light blinking?
    - ◆ No: Continue with the next step.
    - ◆ Yes: Choose from the following:
      - ◇ If the 8mm tape drive is a type 6390, the possible failing part is the 6390 tape drive.
      - ◇ If the 8mm tape drive is a type 7208, the possible failing parts are:
        - a. 7208 tape drive
        - b. Power supply
        - c. AMD

Go to [TUPIP03](#). This ends the procedure.
  5. Perform the read self-test:

### Notes:

- a. The 8mm tape drive read self-test and hardware self-test can take up to 5 minutes to run.
- b. The tape drive runs the read self-test first. During the read self-test, the Read-Write light blinks, and the Disturbance and Ready lights are off.

To start the read self-test and hardware self-test, insert the diagnostic cartridge (part 46G2660) into the tape drive. The following conditions indicate that the read self-test ended successfully:

- ◆ The Read-Write light stops blinking.
- ◆ The diagnostic cartridge ejects automatically.

◆ The three status lights go on to indicate the start of the hardware test.  
Does the read self-test end successfully?

- ◆ No: Does the tape drive eject the diagnostic cartridge?
  - ◇ Yes: Continue with the next step.
  - ◇ No: The tape drive is the failing part.

Go to (Tape cartridge - Manual removal). After removing the diagnostic cartridge, exchange the tape drive (see [Removing and replacing parts](#)). This ends the procedure.

- ◆ Yes: Go to step 8.
6. Is the Disturbance light blinking approximately four times per second?
- ◆ No: Continue with the next step.
  - ◆ Yes: The possible failing part is the diagnostic cartridge (part 46G2660).
    - ◇ If this is your first time through this step, get a new diagnostic cartridge. Go to step 3 of this procedure to clean the tape drive again. Afterwards, run the read self-test and hardware self-test while using the new diagnostic cartridge.
    - ◇ If this is your second time through this step, the possible failing part is the 8mm tape drive. Go to [TUPIP03](#). This ends the procedure.
7. The Disturbance light is blinking approximately once per second.
- ◆ If the 8mm tape drive is a type 6390, the possible failing part is the 6390 tape drive.
  - ◆ If the 8mm tape drive is a type 7208, the possible failing parts are:
    - a. 7208 tape drive
    - b. Power supply
    - c. AMD

Go to [TUPIP03](#). This ends the procedure.

8. The tape drive runs the hardware self-test. During the hardware self-test, the three tape drive status lights are on for 15 to 30 seconds. The three status lights go off when the hardware self-test ends successfully.

Does the hardware self-test end successfully?

- ◆ Yes: Continue with the next step.
- ◆ No: When the hardware self-test does not end successfully, the following conditions occur:
  - ◇ The three status lights do not go off.
  - ◇ The Ready and Read-Write lights go off.
  - ◇ The Disturbance light blinks approximately once per second.
 Possible failing parts are:

- ◇ If the 8mm tape drive is a type 6390, the possible failing part is the 6390 tape drive.
- ◇ If the 8mm tape drive is a type 7208, the possible failing parts are:
  - a. 7208 tape drive
  - b. Power supply
  - c. AMD

Go to [TUPIP03](#). This ends the procedure.

9. The read self-test and hardware self-test ended successfully.

Was the user's original tape identified as the probable cause of failure?

- ◆ Yes: Perform the following:
  - a. Mark and date the data cartridge to indicate that it failed with a permanent error.
  - b. Discard this data cartridge when:
    - Volume statistics (if available) indicate a problem with the data cartridge.
    - A total of three permanent errors have occurred with the same data cartridge.
  - c. If possible, continue operations with a new data cartridge.
 Go to [TUPIP03](#). This ends the procedure.
- ◆ No: Go to [TUPIP03](#). This ends the procedure.

**Parent topic:** [Tape unit isolation procedures](#)

---

## TUPIP03

You were directed here because you may need to exchange a failing part.

The failing part was determined from one of the following:

- Other problem isolation procedures
- The *Failing item* column of the tape unit reference code table
- Tape unit service guide

**Note:** Occasionally, the system is available but not performing an alternate IPL (type D IPL). In this instance, any hardware failure of the tape unit I/O processor, or any device attached to it is not critical. With the exception of the loss of the affected devices, the system remains available.

1. If the system has logical partitions, perform this procedure from the logical partition that reported the problem (see [Determining if the system has logical partitions](#)).
2. Do you need to exchange a possible failing device?
  - ◆ No: Do you need to exchange the tape unit I/O processor?
    - ◇ No: Continue with the next step.
    - ◇ Yes: Exchange the tape unit I/O processor (see [Removing and replacing parts](#)). When you have completed the remove and replace procedure, continue with the next step.
  - ◆ Yes: Perform the following:
    - ◇ For an internal tape unit, go to [Removing and replacing parts](#).
    - ◇ For an external tape unit, go to the remove and replace procedures in the device service information.
3. Are you working with a tape unit in the system unit or in an expansion unit?
  - ◆ Yes: Is the system available, and can you enter commands on the command line?
    - ◇ No: Continue with the next step.
    - ◇ Yes: Go to step [9](#).
  - ◆ No: Continue with the next step.
4. Display the selected IPL type (see [IPL type, mode, and speed options](#) in the [Service functions](#)).

Is the displayed IPL type D?

- ◆ No: Do you want to perform an alternate IPL (type D)?
    - ◇ No: Continue with the next step.
    - ◇ Yes: Go to step [6](#).
  - ◆ Yes: Go to step [6](#).
5. Perform an IPL from disk by doing the following:
    - a. Power off the system (see [Powering on and powering off](#)).
    - b. Select IPL type A in manual mode.
    - c. Power on the system.
    - d. Go to step [8](#).
  6. Place the first tape of the latest set of SAVSYS tapes or SAVSTG tapes, or the first Software Distribution tape in the alternate IPL tape drive. The tape drive automatically becomes ready for the IPL operation (this may take several minutes).
  7. Perform an alternate IPL by doing the following:
    - a. Power off the system.
    - b. Select IPL type D in Manual mode.
    - c. Power on the system.
  8. The IPL may take one or more hours to complete.

Does an unexpected reference code appear on the control panel, and is the System Attention light on?

- ◆ No: Does the IPL complete successfully?
    - ◇ Yes: Continue with the next step.
    - ◇ No: Go to [Start of call procedure](#) to continue analyzing the problem. This ends the procedure.
  - ◆ Yes: Go to step [10](#).
9. Perform the following to test the tape unit:
    - a. Enter `VFY TAP` (the Verify Tape command) on the command line.
    - b. Follow the prompts on the Verify Tape displays, then return here and answer the following question.

Does the `VFYTAB` command end successfully?

- ◆ No: Continue with the next step.
  - ◆ Yes: This ends the procedure.
10. Record the SRC on the Problem summary form (see [Problem reporting forms](#)).

Is the SRC the same one that sent you to this procedure?

- ◆ Yes: You cannot continue to analyze the problem. Use the original SRC and exchange the FRUs. Begin with the FRU which has the highest percent of probable failure (see the failing item list for this reference code). This ends the procedure.
- ◆ No: A different SRC occurred. Use the new SRC to correct the problem (see [Reference codes](#)). This ends the procedure.

**Parent topic:** [Tape unit isolation procedures](#)

---

## TUPIP04

Use this procedure to reset an IOP and its attached tape units. Read the (overview) before continuing with this procedure.

If disk units are attached to an IOP, you must power off the system, then power it on to reset the IOP.

1. If the system has logical partitions, perform this procedure from the logical partition that reported the problem (see [Determining if the system has logical partitions](#)).
2. Is the tape unit powered on?
  - ◆ No: Continue with the next step.
  - ◆ Yes: Perform the following:
    - a. Press the Unload switch on the front of the tape unit you are working on.
    - b. If a data cartridge or a tape reel is present, do not load it until you need it.
    - c. Continue with the next step of this procedure.
3. Verify the following:
  - ◆ If the external device has a power switch, ensure that it is set to the On position.
  - ◆ Ensure that the power and external signal cables are connected correctly.

**Note:** For every 8mm and 1/4 inch tape unit, the I/O bus terminating plug for the SCSI external signal cable is connected internally. These devices do not need and should not have an external terminating plug.

4. Did you press the Unload switch in step 2?
  - ◆ Yes: Can you enter commands on the command line?
    - ◇ Yes: Continue with the next step.
    - ◇ No: Go to step 11.
  - ◆ No: Press the Unload switch on the front of the tape unit you are working on. If a data cartridge or a tape reel is present, do not load it until you need it. Continue with the next step of this procedure.
5. Has the tape unit operated correctly since it was installed? If you do not know, continue with the next step of this procedure.
  - ◆ Yes: Continue with the next step.
  - ◆ No: Go to step 11.
6. If a system message displayed an I/O processor name, a tape unit resource name, or a device name, record the name for use in the next step. You may continue without a name.

Does the I/O processor give support to only one tape unit? If you do not know, continue with the next step of this procedure.

- ◆ No: Continue with the next step.
- ◆ Yes: Perform the following. You must complete all parts of this step before you press Enter.

- a. Enter

```
WRKCFGSTS *DEV *TAP ASTLVL(*INTERMED)
```

(the Work with Configuration Status command) on the command line.

- b. If the device is not varied off, select Vary off before continuing.  
 c. Select Vary on for the failing tape unit.  
 d. Enter

```
RESET(*YES)
```

(the Reset command) on the command line.

- e. Press Enter. This ends the procedure.

7. This step determines if the I/O processor for the tape unit gives support to other tape units or to a disk unit.

**Notes:**

- a. If you cannot determine the tape unit you are attempting to use, go to step 11 (See 11).  
 b. System messages refer to other tape units that the I/O processor gives support to as *associated devices*.

Enter `WRKHDWRSC *STG` (the Work with Hardware Resources command) on the command line.

Did you record an I/O processor (IOP) resource name in step 6?

- ◆ No: Perform the following:
  - a. Select Work with resources for each storage resource IOP (CMB01, SIO1, and SIO2 are examples of storage resource IOPs).
  - b. Find the Configuration name of the tape unit you are attempting to use, and then record the Configuration Description names of all tape units that the I/O processor gives support to.
  - c. Record whether the I/O processor for the tape unit also gives support to any disk unit resources.
  - d. Continue with the next step.
- ◆ Yes: Perform the following:
  - a. Select Work with resources for that resource.
  - b. Record the Configuration description name of all tape units for which the I/O processor provides support.
  - c. Record whether the I/O processor for the tape unit also gives support to any disk unit resources.
  - d. Continue with the next step.

8. Does the I/O processor give support to any disk unit resources?

- ◆ No: Continue with the next step.
- ◆ Yes: The Reset option is not available. Go to step 11.

9. Does the I/O processor give support to only one tape unit?

- ◆ No: Continue with the next step.
- ◆ Yes: Perform the following:
  - a. Select Work with configuration description and press Enter.
  - b. Select Work with status and press Enter.

**Note:** You must complete the remaining parts of this step before you press Enter again.

- c. If the device is not varied off, select Vary off before continuing.  
 d. Select Vary on for the failing tape unit.  
 e. Enter `RESET(*YES)` (the Reset command) on the command line.  
 f. Press Enter. This ends the procedure.

10. Perform the following:

- a. Enter



```
WRKCFGSTS *DEV *TAP ASTLVL(*INTERMED)
```

(the Work with Configuration Status command) on the command line.

- b. Select Vary off for the failing tape unit and associated devices (the devices you identified in step 7), and then press Enter.

**Note:** You must complete the remaining parts of this step before you press Enter again.

- c. Select Vary on for the failing tape unit.
- d. Enter

```
RESET(*YES)
```

(the Reset command) on the command line.

- e. Press Enter.
- f. Select Vary on for the associated devices (tape units) you identified in step 7. It is not necessary to use the Reset option again.

Does a system message indicate that the vary on operation failed?

- ◆ Yes: Continue with the next step.
- ◆ No: This ends the procedure.

11. The Reset is not available, or you were not able to find the Configuration Description name when using

```
WRKHDWRSC *STG
```

(the Work with Hardware Resources command).

You can perform an I/O processor (IOP) reset by performing an IPL of the I/O processor. All devices that are attached to the IOP will reset.

The following steps describe how to load an IOP, how to configure a tape drive, how to vary on tape devices, and how to make tape devices available.

12. Is the tape device you are working on an 8mm tape drive?

- ◆ No: Continue with the next step.
- ◆ Yes: Verify the following on the 8mm tape drive:
  - ◇ The power and external signal cables are connected correctly.
  - ◇ The Power switch is set to the On position (pushed in).

**Note:** The SCSI I/O bus terminating plug for the system-external signal cables is connected internally in the 8mm tape drive. The 8mm tape drive does not need, and must not have an external terminating plug.

Is the 8mm tape drive Power light on, and is the Disturbance light off?

- ◇ Yes: Continue with the next step.
- ◇ No: Go to [TUPIP02](#) to correct the problem. This ends the procedure.

13. Is a data cartridge or a tape reel installed in the tape device?

- ◆ No: Continue with the next step.
- ◆ Yes: Remove the data cartridge or tape reel. Continue with the next step.

14. Can you enter commands on the command line?

- ◆ Yes: Continue with the next step.
- ◆ No: Perform the following:
  - a. Power off the system (see [Powering on and powering off](#)).
  - b. Power on the system.

The system performs an IPL and resets all devices. If the tape device responds to SCSI address 7, the system configures the tape device. This ends the procedure.

15. Verify that automatic configuration is on by entering

```
DSPSYSVAL QAUTOCFG
```

(the Display System Value command) on the command line.

Is the Autoconfigure device option set to 1?

- ◆ Yes: Continue with the next step.
- ◆ No: Perform the following:
  - a. Press Enter to return to the command line.
  - b. Set automatic configuration to On by entering

```
CHGSYSVAL QAUTOCFG '1'
```

(the Change System Value command) on the command line.

**Note:** QAUTOCFG resets to its initial value in step 21.

c. Continue with the next step.

16. Perform the following:

a. Enter

```
STRSST
```

(the Start SST command) on the command line.

- b. On the Start Service Tools Sign On display, type in a User ID with QSRV authority and Password.
- c. Select Start a Service Tool > Hardware Service Manager > Logical Hardware Resources > System Bus Resources. The Logical Hardware Resources on System Bus display shows all of the IOPs.
- d. Find the IOP you want to reset. You must ensure that no one is using any of the tape units, communication channels, or display stations that are attached to the IOP you want to reset.

Does a "\*" indicator appear to the right of the IOP description?

- ◆ No: Continue with the next step.
- ◆ Yes: Disk units are attached to the IOP.

Perform the following:

- a. Press F3 until the Exit System Service Tools display appears.
- b. Press Enter.
- c. Power off the system (see [Powering on and powering off](#)).
- d. Power on the system.

The system performs an IPL and resets all devices. This ends the procedure.

17. Perform the following:

- a. Select I/O debug > IPL the I/O processor.
- b. When the IOP reset is complete, continue with the next step of this procedure.

18. Perform the following:

- a. Press F12 to return to the Logical Hardware Resources on System Bus display.
- b. Select Resources associated with IOP for the IOP you reset.

Did the IOP detect the tape unit?

- ◆ Yes: Continue with the next step.
- ◆ No: The IOP did not detect the tape unit. Consider the following:
  - ◇ Ensure that the tape unit is powered on and that the signal cables are connected correctly. If you find and correct a power or a signal cable problem, return to step 16.
  - ◇ The tape unit may be failing. Go to the tape unit service information and perform the procedures for analyzing device problems. If you find and correct a tape unit problem, return to step 16.
  - ◇ If none of the above are true, ask your next level of support for assistance. This ends the procedure.

19. Press F3 until the Exit System Service Tools display appears. Then press Enter.

20. Was automatic configuration Off before you performed step 15?

- ◆ Yes: Continue with the next step.
- ◆ No: This ends the procedure.

21. Enter

```
CHGSYSVAL QAUTOCFG '0'
```

(the Change System Value command) on the command line to reset QAUTOCFG to its initial value. This ends the procedure.

Parent topic: [Tape unit isolation procedures](#)

---

## TUPIP06

Use this procedure to isolate a Device Not Found message during installation from an alternate device.

There are several possible causes:

- The alternate installation device was not correctly defined.
- The alternate installation device was not made ready.
- The alternate installation device does not contain installation media.
- The alternate installation device is not powered on.
- The alternate installation device is not connected properly.
- There is a hardware error on the alternate installation device or the attached I/O processor.

Read the danger notices in [Tape unit isolation procedures](#) before continuing with this procedure.

1. Is the device that you are using for alternate installation defined as the alternate installation device?
  - ◆ Yes: Is the alternate installation device ready?
    - ◇ Yes: Continue with the next step.
    - ◇ No: Make the alternate installation device ready and retry the alternate installation. This ends the procedure.
  - ◆ No: Correct the alternate installation device information and retry the alternate installation. This ends the procedure.
2. Is there installation media in the alternate installation device?
  - ◆ Yes: Is the alternate installation device an external device?
    - ◇ Yes: Continue with the next step.
    - ◇ No: Go to step 5.
  - ◆ No: Load the correct media and retry the alternate installation. This ends the procedure.
3. Is the alternate installation device powered on?
  - ◆ Yes: Make sure that the alternate installation device is properly connected to the I/O processor or I/O adapter card.
 

Is the alternate installation device properly connected?

    - ◇ Yes: Go to step 5.
    - ◇ No: Correct the problem and retry the alternate installation. This ends the procedure.
  - ◆ No: Continue with the next step.
4. Ensure that the power cable is connected tightly to the power cable connector at the back of the alternate device. Ensure that the power cable is connected to a power outlet that has the correct voltage. Set the alternate device Power switch to the Power On position.

The Power light should go on and remain on. If a power problem is present, one of the following power failure conditions may occur:

- ◆ The Power light flashes, then remains off.
- ◆ The Power light does not go on.
- ◆ Another indication of a power problem occurs.

Does one of the above power failure conditions occur?

- ◆ No: The alternate device is powered on and runs its power-on self-test. Wait for the power-on self-test to complete.

Does the power-on self-test complete successfully?

- ◇ No: Go to the service information for the specific alternate installation device to correct the problem. Then retry the alternate installation. This ends the procedure.
- ◇ Yes: Retry the alternate installation. This ends the procedure.
- ◆ Yes: Perform the following:
  - a. Go to the service information for the specific alternate device to correct the power problem.
  - b. When you have corrected the power problem, retry the alternate installation. This ends the procedure.
- 5. Was a device error recorded in the Product Activity Log?
  - ◆ No: Contact your next level of support. This ends the procedure.
  - ◆ Yes: See [Reference codes](#) to correct the problem. This ends the procedure.

Parent topic: [Tape unit isolation procedures](#)

---

## Tape unit self-test procedure

This procedure is designed to allow you to quickly perform a complete set of diagnostic tests on a 6384 or 6387 tape unit.

The following procedure is designed to allow you to quickly perform a complete set of diagnostic tests on a 6384 or 6387 tape unit, without impacting your system operation. This test can also be used to verify good performance of individual tape cartridges.

Enter diagnostic mode:

1. Verify that a cartridge is not loaded in the tape unit. To unload a cartridge, press the eject button on the front of the tape unit. If the cartridge does not eject, refer to (Tape unit - manual removal).
2. Press and hold the eject button for about 6 seconds until the amber LED starts flashing slowly, then release the button. The amber (left) LED will flash, indicating that the tape unit is waiting for a cartridge to be inserted.

Parent topic: [Tape unit isolation procedures](#)

### Running the self-test

1. Self-testing begins when a scratch data cartridge is inserted into the tape unit. The Ready (left) LED will flash, indicating that self-testing is in progress.

**Note:** A cartridge must be loaded within 15 seconds, otherwise, the tape unit will automatically revert back to normal operation. If necessary, return to step 1 to reenter diagnostic mode.

2. For fastest results, we recommend using an SLR100 Test Tape (P/N 35L0967) .

**Attention:** Use a blank cartridge that does not contain customer data. During this self-test, the cartridge will be rewritten with a test pattern and any customer data will be destroyed.

**Note:** Use a cartridge that is not write-protected. If a write-protected cartridge is inserted while the tape unit is in diagnostic mode, the cartridge will be ejected, see [Incorrect cartridge](#) below.

Self-testing will only be performed using a write-compatible cartridge type, and with a cartridge that is not damaged, see [Incorrect cartridge](#) below.

If a cleaning cartridge is inserted while the tape unit is in diagnostic mode, drive cleaning will occur and the tape unit will then return to normal operating mode. Return to step 1 to reenter diagnostic

mode.

3. **At any time, self-testing can be stopped by pressing the eject button.** After the current operation is completed, the cartridge will be ejected and tape unit will return to normal operating mode.
4. The Ready (left) LED will continue to flash during the following:
  - ◆ The cartridge load sequence has a approximate duration of 30 seconds. The center LED indicates tape movement.
  - ◆ The hardware test has an approximate duration of 2 and 1/2 minutes. During that time, a static test is performed on tape unit electrical components. No tape motion occurs during this step.
  - ◆ The cartridge load/unload test has an approximate duration of 1 and 1/2 minutes. During that time, the Ready LED will continue to flash while a dynamic test is performed on tape unit mechanical components. Two cartridge load cycles are included.
  - ◆ Duration of the write/read test will vary, depending on what type of cartridge is loaded into the tape unit. When an SLR100 Test Tape is used, typical duration will be 5 minutes. Use of other cartridge types can increase the write/read test duration to 30-40 minutes. During this test, the Ready LED will continue to flash. The center LED indicates tape movement.

#### Interpreting the results

**Test Passed:** When self-testing has completed successfully, and no problems are detected, the cartridge is unloaded from the tape unit and all LEDs are off. Proper function of both the tape unit and tape cartridge have now been verified.

**Note:** A solid amber light indicates that self-testing has completed successfully, but the tape unit requires cleaning. Clean the tape unit by inserting an Dry Process Cleaning Cartridge (P/N 35L0844).

**Test Failed:** The cartridge will remain loaded inside the tape unit, and the amber LED will flash when a problem is detected with either the tape unit or cartridge.

**Note:** To isolate failure to either tape unit or cartridge, return to step 1 and repeat this self-test using a different scratch cartridge.

**Incorrect cartridge:** When the center (green) and right (amber) LEDs flash and a cartridge is unloaded, the tape unit has determined that an incorrect tape cartridge has been inserted, and self-testing cannot be performed. Verify that your tape cartridge is not one of the following:

- Write-protected
- Damaged
- Unsupported media type
- Media which is not write-compatible with tape unit.

Press the eject button, to end self-test and return the tape unit to normal operating mode. Then return to step 1 and run the self-test using another cartridge, or one which is not write-protected. This ends the procedure.

---

## Tape device ready conditions

All the conditions that are listed for the device, must be correct for the device to be ready.

If the device is not ready, use the Action column or other instructions, and go to the service information for the specific tape device.

If the system has logical partitions, perform this procedure from the logical partition that reported the problem (see [Determining if the system has logical partitions](#)).

Table 1. Tape device ready conditions

| Storage device | Ready description                                                                                                                                                                                                                                                                                                                                                                                                                                                                                                                                          | Action                                                                                                                                                                                                                                               |
|----------------|------------------------------------------------------------------------------------------------------------------------------------------------------------------------------------------------------------------------------------------------------------------------------------------------------------------------------------------------------------------------------------------------------------------------------------------------------------------------------------------------------------------------------------------------------------|------------------------------------------------------------------------------------------------------------------------------------------------------------------------------------------------------------------------------------------------------|
| 3480 or 3490   | <ul style="list-style-type: none"> <li>• Power switch is set to the On position.</li> <li>• Power light is on.</li> <li>• DC Power light is on.</li> <li>• Control unit On-line switch is set to the On-line position.</li> <li>• Control unit Normal/Test switch is set to the Normal position.</li> <li>• Control unit channel Enable/Disable switch is set to the Enable position.</li> <li>• Tape unit On-line/Off-line switch is set to the On-line position.</li> <li>• Tape is loaded.</li> <li>• Tape unit displays Ready U or Ready F.</li> </ul> | See the <i>3480 Magnetic Tape Subsystem Operator's Guide</i> , SA32-0066, or <i>3490 Magnetic Tape Subsystem Operator's Guide</i> , SA32-0124, for instructions on making the tape unit ready.                                                       |
| 7208           | <ul style="list-style-type: none"> <li>• Power switch is on (pressed).</li> <li>• Power light is on.</li> <li>• Data cartridge is inserted.</li> <li>• Ready light is on.</li> <li>• System external signal cable is connected to the type 2621 I/O processor and to the 7208 tape drive.</li> </ul> <p><b>Note:</b> The SCSI I/O bus terminating plug for the system external signal cable is connected internally in the 7208 tape drive. The 7208 tape drive does not need, and must not have, an external terminating plug.</p>                        | See the <i>7208 8 mm Tape Drive Operator's Manual</i> for instructions on making the tape drive ready. If you cannot make the 7208 Model 012 tape drive ready, go to <a href="#">TUPIP02</a> .                                                       |
| 9348           | <ul style="list-style-type: none"> <li>• Power switch is set to the On position.</li> <li>• Power light is on.</li> <li>• Tape is loaded.</li> <li>• Status display shows 00 A002.</li> <li>• On-line light is on.</li> </ul>                                                                                                                                                                                                                                                                                                                              | See the <i>9348 Customer Information</i> manual, SA21-9567, for instructions on making the tape unit ready. If you cannot make the tape unit ready, go to the "Analyzing Problems" section of <i>9348 Tape Unit Service Information</i> , SY31-0697. |

Parent topic: [Tape unit isolation procedures](#)

## Twinaxial workstation I/O processor isolation procedure

Use the procedure below to isolate a failure which has been detected by the twinaxial workstation I/O processor. If you are using a personal computer, an emulation program must be installed and working.

Please read and observe all safety procedures before servicing the system and while performing the procedure below.

**Attention:** Unless instructed otherwise, always power off the system or expansion tower where the FRU is located (see [Powering on and powering off](#)) before removing, exchanging, or installing a field-replaceable unit (FRU).

### **DANGER**When working on or around the system, observe the following precautions:

Electrical voltage and current from power, telephone, and communication cables are hazardous. To avoid a shock hazard:

- Connect power to this unit only with the provided power cord. Do not use the provided power cord for any other product.
- Do not open or service any power supply assembly.
- Do not connect or disconnect any cables or perform installation, maintenance, or reconfiguration of this product during an electrical storm.
- The product might be equipped with multiple power cords. To remove all hazardous voltages, disconnect all power cords.
- Connect all power cords to a properly wired and grounded electrical outlet. Ensure that the outlet supplies proper voltage and phase rotation according to the system rating plate.
- Connect any equipment that will be attached to this product to properly wired outlets.
- When possible, use one hand only to connect or disconnect signal cables.
- Never turn on any equipment when there is evidence of fire, water, or structural damage.
- Disconnect the attached power cords, telecommunications systems, networks, and modems before you open the device covers, unless instructed otherwise in the installation and configuration procedures.
- Connect and disconnect cables as described in the following procedures when installing, moving, or opening covers on this product or attached devices.
  - To Disconnect:
    1. Turn off everything (unless instructed otherwise).
    2. Remove the power cords from the outlets.
    3. Remove the signal cables from the connectors.
    4. Remove all cables from the devices

To Connect:

1. Turn off everything (unless instructed otherwise).
2. Attach all cables to the devices.
3. Attach the signal cables to the connectors.
4. Attach the power cords to the outlets.
5. Turn on the devices.

(D005)

**Attention:** When instructed, remove and connect cables carefully. You may damage the connectors if you use too much force.

- **TWSIP01**  
The workstation IOP detected an error.

## TWSIP01

The workstation IOP detected an error.

Please read the danger notices in [Twinaxial workstation I/O processor isolation procedure](#) before performing this procedure.

One of the following occurred:

- All of the workstations on one port are not working.
- All of the workstations on the system are not working.
- One of the workstations on the system is not working.
- The reference code table instructed you to perform this procedure.
- The Remote Operations Console is not working.

1. If the system has logical partitions, perform this procedure from the logical partition that reported the problem. To determine if the system has logical partitions, go to [Determining if the system has logical partitions](#) before continuing with this procedure.
2. Are you using a workstation adapter console?

**Note:** A personal computer (used as a console) that is attached to the system by using a console cable feature is known as a workstation adapter console. The cable (part number 46G0450, 46G0479, or 44H7504) connects the system port on the personal computer to a communications I/O adapter on the system.

- ◆ No: Continue with the next step.
  - ◆ Yes: Go to [WSAIP01](#). This ends the procedure.
3. Is the device you are attempting to repair a personal computer (PC)?
    - ◆ No: Continue with the next step.
    - ◆ Yes: PC emulation programs operate and report system-to-PC communications problems differently. See the PC emulation information for details on error identification. Then, continue with the next step.
  4. Perform the following steps:
    - a. Verify that all the devices you are attempting to repair, the primary console, and any alternative consoles are powered on.
    - b. Verify that all the devices you are attempting to repair, the primary console, and any alternative consoles have an available status. For more information on displaying the device status, see [Hardware Service Manager](#).
    - c. Verify that the workstation addresses of all workstations on the failing port are correct. Each workstation on the port must have a separate address, from 0 through 6. See the workstation service information for details on how to check addresses.
    - d. Verify that the last workstation on the failing port is terminated. All other workstations on that port must not be terminated.
    - e. Ensure that the cables that are attached to the device or devices are tight and are not visibly damaged.
    - f. If there were any cable changes, check them carefully.
    - g. If all of the workstations on the system are not working, disconnect them by terminating at the console.
    - h. Verify the device operation (see the device information for instructions).
      - i. The cursor position can assist in problem analysis.
        - ◇ If the cursor is in the upper right corner, it indicates a communication problem between the workstation IOP and the device. Continue with the next step.
        - ◇ If the cursor is in the upper left corner, it indicates a communication problem between the workstation IOP and the operating system. Perform the following steps:
          - i. Verify that all current PTFs are loaded.



- ii. Ask your next level of support for assistance. This ends the procedure.
- 5. Is the system powered off?
  - ◆ Yes: Continue with the next step.
  - ◆ No: Go to step 8.
- 6. Perform the following:
  - a. Power on the system in Manual mode. See [IPL type, mode, and speed options](#) for details.
  - b. Wait for a display to appear on the console or a reference code to appear on the control panel.

Does a display appear on the console?

- ◆ No: Continue with the next step.
- ◆ Yes: If you disconnected any devices after the console in step 4, perform the following:
  - a. Power off the system.
  - b. Reconnect one device.

**Note:** Ensure that you terminate the device you just reconnected and remove the termination from the device previously terminated.

- c. Power on the system.
- d. If a reference code appears on the control panel, go to step 9.
- e. If no reference code appears, repeat steps a through d of this step until you have checked all devices disconnected previously.
- f. Continue to perform the initial program load (IPL). This ends the procedure.
- 7. Does the same reference code that sent you to this procedure appear on the control panel?
  - ◆ Yes: Continue with the next step.
  - ◆ No: Go to [Start of call procedure](#) for this new problem. This ends the procedure.
- 8. Perform the following to make DST available:
  - a. Ensure that Manual mode on the control panel is selected.
  - b. Select function 21 Make DST Available.
  - c. Check the console and any alternative consoles for a display.

Does a display appear on any of the console displays?

- ◆ No: Continue with the next step.
- ◆ Yes: If you disconnected any devices after the console in step 4, perform the following:
  - a. Power off the system.
  - b. Reconnect one device.

**Note:** Ensure that you terminate the device you just reconnected and remove the termination from the previously terminated device.

- c. Power on the system.
- d. If a reference code appears on the control panel or on the HMC, go to step 9.
- e. If no reference code, repeat steps a through d of this step until you have checked all devices disconnected previously.
- f. Continue to perform the initial program load (IPL). This ends the procedure.
- 9. Ensure that the following conditions are met:
  - ◆ The workstation addresses of all workstations on the failing port must be correct.

Each workstation on the port must have a separate address, from 0 through 6. See the workstation service information if you need help with checking addresses.

Did you find a problem with any of the above conditions?

- ◆ Yes: Continue with the next step.
  - ◆ No: Go to step 11.
  - 10. Perform the following:
    - a. Correct the problem.
    - b. Select function 21 Make DST Available.
    - c. Check the console and any alternative consoles for a display.
- Does a display appear on any of the consoles?

- ◆ Yes: Continue to perform the IPL. This ends the procedure.

- ◆ No: Does the same reference code appear on the control panel?
  - ◇ Yes: Continue with the next step.
  - ◇ No: Go to [Start of call procedure](#) for this new problem. This ends the procedure.
- 11. Is the reference code one of the following: 0001, 0003, 0004, 0005, 0006, 0101, 0103, 0104, 0105, 0106, 5004, 5082, B000, D010, or D023?
  - ◆ No: Continue with the next step.
  - ◆ Yes: Go to step [15](#).
- 12. Does the system have an alternative console on a second workstation IOP?
  - ◆ Yes: Continue with the next step.
  - ◆ No: Go to step [14](#).
- 13. There is either a Licensed Internal Code problem, or there are two device failures on the workstation IOPs, consoles, or cables. The console and any alternative consoles are the most probable causes for this failure.
  - ◆ See the service information for the failing display to attempt to correct the problem. If a display is connected to the system by a link protocol converter, use the link protocol converter information to attempt to correct the problem. The link protocol converter may be the failing item.
  - ◆ If you have another working display, you can exchange the console and alternative consoles and perform an IPL to attempt to correct the problem.
  - ◆ Exchange the following parts one at a time until you determine the failing item:
    - a. Console
    - b. Alternative console
    - c. Cables
    - d. Workstation IOA for the console
    - e. The multi-adapter bridge. See symbolic FRU [MA\\_BRDG](#). This ends the procedure.
- 14. The console, cables, or the workstation IOP card is the most probable causes for this failure. If the console is connected to the system by a link protocol converter, the link protocol converter is possibly the failing item. Use one or more of the following options to correct the problem:
  - a. See the service information for the failing displays for more information. If a display is connected to the system by a link protocol converter, see the link protocol converter information to attempt to correct the problem.
  - b. If you have another working display, you can exchange the console and perform an IPL to attempt to correct the problem.
  - c. Exchange the following parts one at a time until you determine the failing item:
    - i. Console
    - ii. Workstation IOA
    - iii. The multi-adapter bridge. See symbolic FRU [MA\\_BRDG](#).
    - iv. Twinaxial attachment (cable) This ends the procedure.
- 15. To continue problem analysis, use a port tester, part 93X2040 or 59X4262, which you may have with your tools or the customer may have one. The port tester has either two or three lights.

Is a port tester available?

- ◆ Yes: Continue with the next step.
- ◆ No: Check or exchange the cables from the system to the failing display. Did this correct the problem?
  - ◇ Yes: You corrected the problem. This ends the procedure.
  - ◇ No: Go to step [12](#).
- 16. To use the port tester to isolate the problem, perform the following:
  - ◆ Verify that the port tester is operating correctly by doing a self-test. A self-test can be made at any time, even when the port tester is attached to a port or cable. Perform the following steps to do a self-test:
    - a. Move the selector switch to the center (0) position.
    - b. Push and hold the test button until all lights go on. The yellow lights should go on immediately, and the green light should go on approximately 5 seconds later. The port tester is ready for use if all lights go on.
  - ◆ Leave the system power on.
- 17. Find the input cable to the failing console or port.

Is the failing console or the failing port attached to a protocol converter?

- ◆ No: Perform the following:
  - a. Disconnect the input cable from the failing console.
  - b. Connect the port tester to the input cable.
  - c. Continue with the next step.
- ◆ Yes: Perform the following:
  - a. Disconnect the cable that comes from the system at the protocol converter.

- b. Connect the port tester to the cable.
  - c. Continue with the next step.
18. Perform the following:
- a. Set the selector switch on the port tester to the left (1) position for a twinaxial connection. Set the switch to the right (2) position for a twisted pair connection.
  - b. Press and hold the test switch on the port tester for 15 seconds and observe the lights.
  - c. Choose from the following options:
    - ◊ If the port tester has three lights, do the following:
      - If only the top (green) light is on, go to step 27.
      - If both the top (green) and center (yellow) lights are on, go to step 20.
    - ◊ If the port tester has two lights, do the following:
      - If only the top (green) light is on, go to step 27.
      - If only the bottom (yellow) light is on, go to step 21.
      - If both lights are off, go to step 22.
      - If both lights are on, continue with the next step.
19. The tester is in the self-test mode. Check the position of the selector switch.
- ◆ If the selector switch is not in the correct position, go to step 18.
  - ◆ If the selector switch is already in the correct position, the port tester is not working correctly. Exchange the port tester, and go to step 16.
20. The cable you are testing has an open shield.

**Note:** The open shield can be checked only on the cable from the twinaxial workstation attachment to the device or from device to device. Only one section of cable can be checked at a time. See the SA41-3136, Port Tester Use information.

This ends the procedure.

21. The cable network is bad. The wires in the cable between the console and the twinaxial workstation attachment are reversed. Go to step 26.
22. Perform the following:
- a. Find the twinaxial workstation attachment to which the failing console is attached.
  - b. Disconnect the cable from port 0 on that twinaxial workstation attachment.
  - c. Connect the port tester to port 0 on the attachment.
  - d. Set the selector switch on the port tester to the left (1) position.
23. Perform the following:
- a. Press and hold the test switch on the port tester for 15 seconds and observe the lights.
  - b. If the port tester has three lights, do the following:
    - ◊ If both the top (green) and center (yellow) lights are on, continue with step 24.

**Note:** The center (yellow) light is always on for twisted pair cable and may be on for fiber optical cable.

- ◊ If only the bottom (yellow) light is on, continue with step 24.
  - ◊ If all lights are off, continue with step 24.
  - ◊ If only the top (green) light is on, go to step 26.
  - ◊ If all lights are on, go to step 25.
- c. If the port tester has two lights, do the following:
- ◆ If only the top (green) light is on, go to step 26.
  - ◆ If only the bottom (yellow) light is on, continue with step 24.
  - ◆ If both lights are off, continue with step 24.
  - ◆ If both lights are on, go to step 25.

24. The test indicated that there was no signal from the system. Reconnect the cable you disconnected and perform the following:
  - a. Exchange the following parts:
    - i. Twinaxial workstation IOA card
    - ii. The multi-adapter bridge. See symbolic FRU [MA\\_BRDG](#).
  - b. Power on the system to perform an IPL. This ends the procedure.
25. The tester is in the self-test mode. Check the position of the selector switch:
  - ◆ If the selector switch is not in the left (1) position, set the switch to the left (1) position. Then go to step [23](#).
  - ◆ If the selector switch is already in the left (1) position, the port tester is not working correctly. Exchange the port tester and go to step [22](#).
26. The cable to the workstation is the failing item. Cable maintenance is a customer responsibility. The cable must be repaired or exchanged. For information on correcting cable problems, refer to the [Twinaxial cables](#) information in the Planning topic. For other cabling instructions, see the [Plan for cables](#) topic. Then, power on the system to perform an IPL. This ends the procedure.
27. The port tester detects most problems, but it does not always detect an intermittent problem or some cable impedance problems. The tester may indicate a good condition, although there is a problem with the workstation IOP card or cables.
  - a. If the failing display is connected to a link protocol converter, the link protocol converter is the failing item. See the link protocol converter service information to correct the problem.
  - b. Exchange the following parts:
    - i. Console
    - ii. Twinaxial workstation IOA
    - iii. The multi-adapter bridge. See symbolic FRU [MA\\_BRDG](#).
    - iv. Cables
  - c. If you have another working display, you can exchange the console and perform an IPL to attempt to correct the problem. See the service information for the failing display for more information.
  - d. If exchanging the failing items did not correct the problem and the reference code was a 5002, 5082, or 50FF, there may be a Licensed Internal Code problem. Go to [LICIP03](#).
  - e. The problem may be caused by devices that are attached after the console on port 0. This ends the procedure.

**Parent topic:** [Twinaxial workstation I/O processor isolation procedure](#)

---

## Workstation adapter isolation procedure

Contains the procedure necessary to isolate a failure that is detected by the workstation adapter, and is used when no display is available with which to perform on-line problem analysis.

The workstation adapter detected a problem while communicating with the workstation that is used as the primary console.

**Note:** If you are using a PC, you must install an emulation program.

Please read and observe all safety procedures before servicing the system and while performing the procedure below.

**Attention:** Unless instructed otherwise, always power off the system or expansion tower where the FRU is located (see [Powering on and powering off](#)) before removing, exchanging, or installing a field-replaceable unit (FRU).

**DANGER**When working on or around the system, observe the following precautions:

Electrical voltage and current from power, telephone, and communication cables are hazardous. To avoid a shock hazard:

- Connect power to this unit only with the provided power cord. Do not use the provided power cord for any other product.
- Do not open or service any power supply assembly.
- Do not connect or disconnect any cables or perform installation, maintenance, or reconfiguration of this product during an electrical storm.
- The product might be equipped with multiple power cords. To remove all hazardous voltages, disconnect all power cords.
- Connect all power cords to a properly wired and grounded electrical outlet. Ensure that the outlet supplies proper voltage and phase rotation according to the system rating plate.
- Connect any equipment that will be attached to this product to properly wired outlets.
- When possible, use one hand only to connect or disconnect signal cables.
- Never turn on any equipment when there is evidence of fire, water, or structural damage.
- Disconnect the attached power cords, telecommunications systems, networks, and modems before you open the device covers, unless instructed otherwise in the installation and configuration procedures.
- Connect and disconnect cables as described in the following procedures when installing, moving, or opening covers on this product or attached devices.

To Disconnect:

1. Turn off everything (unless instructed otherwise).
2. Remove the power cords from the outlets.
3. Remove the signal cables from the connectors.
4. Remove all cables from the devices

To Connect:

1. Turn off everything (unless instructed otherwise).
2. Attach all cables to the devices.
3. Attach the signal cables to the connectors.
4. Attach the power cords to the outlets.
5. Turn on the devices.

(D005)

- **WSAIP01**

Use this procedure if your console has a keyboard error with a "K" on the display.

**Parent topic:** [Isolation procedures](#)

---

## WSAIP01

Use this procedure if your console has a keyboard error with a "K" on the display.

**Note:** If the console has a keyboard error, there may be a "K" on the display. See the workstation service information for more information.

Perform the following procedure from the logical partition that reported the problem:

1. Select the icon on the workstation to make it the console (you may have already done this). You must save the console selection.
2. Access Dedicated Service Tools (DST) by performing the following:
  - a. Select Manual mode on the control panel.
  - b. Use the selection switch on the control panel to display function 21, Make DST Available, and press Enter on the control panel.

- c. Wait for a display to appear on the console or for a reference code to appear on the control panel.

Does a display appear on the console?

- ◆ No: Continue with the next step.
- ◆ Yes: The problem is corrected. This ends the procedure.

3. Isolate the problem to one server and one workstation (console) by performing the following:
  - a. Disconnect the power cable from the workstation.
  - b. Eliminate all workstations, cables, and connector boxes from the network except for one server, one console, two connector boxes, and one cable.
  - c. Ensure that the cables that are connected to the console, the keyboard, and the server are connected correctly and are not damaged.
4. Perform the following:
  - a. Ensure that the server console is terminated correctly.
  - b. Set the Power switch on the console to the On position.
  - c. Select the SNA\*PS icon on the console.
  - d. See the workstation information for more information.
5. Access DST by performing the following:
  - a. Select Manual mode on the control panel.
  - b. Use the selection switch on the control panel to display function 21, Make DST Available, and press Enter on the control panel.
  - c. Wait for a display to appear on the console or for a reference code to appear on the control panel.

Does a display appear on the console?

- ◆ No: Continue with the next step.
- ◆ Yes: The problem is in a cable, connector box, or device you disconnected in step 3. This ends the procedure.

6. Does the reference code A600 5005 appear on the control panel?
  - ◆ Yes: Continue with the next step.
  - ◆ No: Return to [Start of call procedure](#). This ends the procedure.
7. Do you have another workstation, cable, and two connector boxes you can exchange with the workstation connected to the server?
  - ◆ Yes: Continue with the next step.
  - ◆ No: One of the following is causing the problem:

**Note:** The items at the top of the list have a higher probability of fixing the problem than the items at the bottom of the list.

- ◇ Workstation adapter Licensed Internal Code
- ◇ Workstation adapter configuration
- ◇ Workstation
- ◇ Cable
- ◇ Connector box
- ◇ Workstation IOA
- ◇ Workstation IOP

If you still have not corrected the problem, ask your next level of support for assistance. This ends the procedure.

8. Repeat steps 3 through 7 of this procedure, using a different workstation, cable, and connector boxes.

Do you still have a problem?

- ◆ Yes: Continue with the next step.
- ◆ No: The problem is in the cable, connector boxes, or workstation you disconnected. This ends the procedure.

9. One of the following is causing the problem:

**Note:** The items at the top of the list have a higher probability of fixing the problem than the items at the bottom of the list.

- ◆ Workstation adapter Licensed Internal Code
- ◆ Workstation adapter configuration
- ◆ Workstation IOA
- ◆ Communications IOP

To bring up a workstation other than the console, perform the following:

- a. Connect another workstation into this network.
- b. Select Normal mode on the control panel.
- c. Perform an IPL (see [IPL information](#) in the [Service functions](#)).

If the sign-on display appears, the following parts are good:

- ◆ Communications IOP
- ◆ Workstation IOA

**Note:** If a printer connected to this assembly is not working correctly, it may look like the display is bad. Perform a self-test on the printer to ensure that it prints correctly (see the printer service information).

If you still have not corrected the problem, ask your next level of support for assistance. This ends the procedure.

**Parent topic:** [Workstation adapter isolation procedure](#)

---

## Workstation adapter console isolation procedure

Contains the procedure necessary to isolate a failure that is detected by the workstation adapter console.

Use this procedure when no display is available with which to perform online problem analysis.

**Note:** If you are using a PC, you must install an emulation program.

Read all safety procedures before servicing the system. Observe all safety procedures when performing a procedure. Unless instructed otherwise, always power off the system or expansion tower where the FRU is located, see [Powering on and powering off](#) before removing, exchanging, or installing a field-replaceable unit (FRU).

### **DANGER**When working on or around the system, observe the following precautions:

Electrical voltage and current from power, telephone, and communication cables are hazardous. To avoid a shock hazard:

- Connect power to this unit only with the provided power cord. Do not use the provided power cord for any other product.
- Do not open or service any power supply assembly.
- Do not connect or disconnect any cables or perform installation, maintenance, or reconfiguration of this product during an electrical storm.
- The product might be equipped with multiple power cords. To remove all hazardous voltages, disconnect all power cords.
- Connect all power cords to a properly wired and grounded electrical outlet. Ensure that the outlet supplies proper voltage and phase rotation according to the system rating plate.
- Connect any equipment that will be attached to this product to properly wired outlets.
- When possible, use one hand only to connect or disconnect signal cables.
- Never turn on any equipment when there is evidence of fire, water, or structural damage.

- Disconnect the attached power cords, telecommunications systems, networks, and modems before you open the device covers, unless instructed otherwise in the installation and configuration procedures.
- Connect and disconnect cables as described in the following procedures when installing, moving, or opening covers on this product or attached devices.

To Disconnect:

1. Turn off everything (unless instructed otherwise).
2. Remove the power cords from the outlets.
3. Remove the signal cables from the connectors.
4. Remove all cables from the devices

To Connect:

1. Turn off everything (unless instructed otherwise).
2. Attach all cables to the devices.
3. Attach the signal cables to the connectors.
4. Attach the power cords to the outlets.
5. Turn on the devices.

(D005)

Read and understand the following service procedures before using this section:

- [Powering on and powering off](#)
- [Determining a primary or alternative console](#) in [Service functions](#).
- Card removal and replacement in [Removing and replacing parts](#)
- [Finding part locations](#)

**Note:** If the console has a keyboard error, there may be a K on the display. See the workstation service information for more information.

1. If the system has logical partitions, perform this procedure from the logical partition that reported the problem. To determine if the system has logical partitions, go to [Determining if the system has logical partitions](#).
2. Ensure that your workstation meets the following conditions:
  - ◆ The workstation that you are using for the console is powered on.
  - ◆ The emulation program is installed and is working.
  - ◆ The input/output adapter (IOA) is installed and the workstation console cable is attached.

**Notes:**

- a. Card information: Hardware that is associated with 6A59 feature is the type 2745 card.
- b. Cable information: The cable attaches directly to the IOA.

Did you find a problem with any of the conditions listed above?

- ◆ No: Continue with the next step.
  - ◆ Yes: Correct the problem. Then, perform an IPL of the system. This ends the procedure.
3. Perform the following to make dedicated service tool (DST) available:
    - a. If there is an alternative console, ensure that it is powered on.
    - b. Ensure that Manual mode on the control panel is selected. See [Service functions](#).
    - c. Select function 21, Make DST Available on the control panel, and press Enter.

Does a display appear on either the console or any alternative console?

- ◆ No: Continue with the next step.
- ◆ Yes: Complete the IPL. When the operating system display appears, use the Work with Problem command (`WRKPRB`) or Analyze Problem command (`ANZPRB`) to analyze and correct or report any console problems. This ends the procedure.



4. Do you have SRC A600 5001, A600 5004, A600 5007, or B075 xxxx (where xxxx is any value)?
  - ◆ No: Continue with the next step.
  - ◆ Yes: Perform the following:
    - a. Disconnect any cables that are attached to the IOA.
    - b. Install the wrap plug on the IOA. The 2745 wrap plug label is QQ.
    - c. Perform an IPL in Manual mode.
5. Does SRC 6A59 5007 occur?
  - ◆ No: Continue with the next step.
  - ◆ Yes: One of the following is causing the problem:
    - ◇ Workstation emulation program
    - ◇ Workstation
    - ◇ Workstation console cable
 This ends the procedure.
6. Did SRC A600 5001, A600 5004, or 6A59 5008 occur?
  - ◆ No: This is a new problem. Use the new reference code to correct the problem, see [Reference codes](#), or ask your next level of support for assistance. This ends the procedure.
  - ◆ Yes: The Type 2745 workstation adapter is the failing item. This ends the procedure.

Parent topic: [Isolation procedures](#)

---

## AIX fast-path problem isolation

Use this information to help you isolate a hardware problem and the server is running the AIX operating system.

In most cases, AIX diagnostics are performed through automatic error log analysis. In some cases, these procedures direct you to run online diagnostics. Standalone diagnostics should only be used if you are unable to boot AIX or are otherwise specifically directed to do so.

### Notes:

1. If the server or partition has an external SCSI disk drive enclosure attached and you have not been able to find a reference code or other symptom, go to [MAP 2010: D24 or T24 START](#).
2. If you are servicing an SP system, go to the Start of Call MAP 100 in the [SP System Service Guide](#).
3. If you are servicing a clustered server that has InfiniBand (IB) switch networks, go to [referenceinfiniband.htm](#) and open the book entitled [Guide to Clustering systems using InfiniBand \(IB\) hardware](#).

**Note:** If you already know the reference code or have another symptom other than a reference code, go directly to the [AIX fast path table](#).

Use the following procedure to display or confirm a previously reported reference code including an SRN.

1. Log into the AIX operating system as the root user, or use the CE login. If you need assistance, contact the system operator.
2. Enter the diag command. The diag command allows you to load the diagnostic controller and display the online diagnostic menus.
3. Press Enter. This opens the FUNCTION SELECTION menu.
4. Select Task Selection.
5. Select Display Previous Diagnostic Results.
6. Select DISPLAY DIAGNOSTIC LOG SUMMARY. A display diagnostic log summary table is shown with a time ordered table of events from the error log.

7. Look for the most recent S entry in the T column. The most recent S entry is the one closest to the beginning of the DISPLAY DIAGNOSTIC LOG SUMMARY table.
8. Move your cursor over the row containing the S entry and press Enter.
9. Press F7 to Commit.

A screen containing details from the table is displayed; look for the reference code (SRN or SRC) entry. The SRN or SRC entry is shown near the bottom of the screen.

10. Record the reference code.

The following example, which shows the details of an SRN, is similar to what you should see on your terminal when you perform the above procedure.

```

DISPLAY DIAGNOSTIC LOG                                     802004
TOP
-----
IDENTIFIER:                DAFE

Date/Time:                 Fri Aug 27 17:57:54
Sequence Number:          952
Event type:               SRN Callout

Resource Name:             ent1
Resource Description:      Gigabit Ethernet-SX Adapter (e414a816)
Location:                 U8842.P1Z.23A0781-P1-T7

Diag Session:             21546
Test Mode:                No Console,Non-Advanced,Normal IPL,ELA,Option Checkout

Error Log Sequence Number: 2189
Error Log Identifier:      6363CE4F

SRN:                      25C4-601

Description:               Download Firmware Error.

Probable FRUs:
  ent1                    FRU: BCM95704A41          U8842.P1Z.23A0781-P1-T7
                        Gigabit Ethernet-SX Adapter (e414a816)
-----
BOTTOM
Use Enter to continue.

Esc+3=Cancel      Esc+0=Exit      Enter
    
```

11. If any reference codes are displayed, record all information provided from the diagnostic results and go to [Reference codes](#).

OR

If a *no trouble found* is displayed continue to the next step.

12. When your results are complete, press F3 to return to the Diagnostic Operating Instructions display.
13. Press Ctrl + D to log off from being either the root user or CE login user.

## AIX fast path table

Locate the problem in the following table and perform the action indicated.

| Symptoms                            | Action                                                                                                                             |
|-------------------------------------|------------------------------------------------------------------------------------------------------------------------------------|
| <b>Eight-Digit Error Codes</b>      |                                                                                                                                    |
| You have an eight-digit error code. | Go to <a href="#">Reference codes</a> , read the notes on the first page, and do the listed action for the eight-digit error code. |

|                                                                                                            |                                                                                                                                                                                                                                                                                                                                                                                                                                                                                                                                                                                                  |
|------------------------------------------------------------------------------------------------------------|--------------------------------------------------------------------------------------------------------------------------------------------------------------------------------------------------------------------------------------------------------------------------------------------------------------------------------------------------------------------------------------------------------------------------------------------------------------------------------------------------------------------------------------------------------------------------------------------------|
|                                                                                                            | <b>Note:</b> If the repair for this code does not involve replacing a FRU (for instance, if you run an AIX command that fixes the problem or if you change a hot-pluggable FRU), then run the Log Repair Action option on resource sysplanar0 from the Task Selection menu under online diagnostics after the problem is resolved to update the AIX error log.                                                                                                                                                                                                                                   |
| <b>SRNs</b>                                                                                                |                                                                                                                                                                                                                                                                                                                                                                                                                                                                                                                                                                                                  |
| You have an SRN.                                                                                           | Look up the SRN in the <a href="#">List of service request numbers</a> and do the listed action.<br><b>Note:</b> Customer-provided SRNs should be verified. To verify the SRN use the <a href="#">Display Previous Diagnostic Results Service Aid</a> . Choose the Display Diagnostic Log Summary when running this service aid.                                                                                                                                                                                                                                                                 |
| An SRN is displayed when running diagnostics.                                                              | <ol style="list-style-type: none"> <li>1. Record the SRN and location code.</li> <li>2. Look up the SRN in the <a href="#">List of service request numbers</a> and do the listed action.</li> </ol>                                                                                                                                                                                                                                                                                                                                                                                              |
| <b>888 Sequence in Operator Panel Display</b>                                                              |                                                                                                                                                                                                                                                                                                                                                                                                                                                                                                                                                                                                  |
| An 888 sequence in the operator panel display.                                                             | Go to <a href="#">MAP 0070: 888 Sequence in operator panel display</a> .                                                                                                                                                                                                                                                                                                                                                                                                                                                                                                                         |
| <b>The System Stops or Hangs With a Value Displayed in the Operator Panel Display</b>                      |                                                                                                                                                                                                                                                                                                                                                                                                                                                                                                                                                                                                  |
| The system stopped with a 4-digit code that begins with a 2 (two) displayed in the operator panel display. | Record SRN 101-xxxx (where xxxx is the four digits of code displayed). The physical location code or device name displays on system units with a multiple-line operator panel display. If a physical location code or an AIX location code is displayed, record it, then look up the SRN in the <a href="#">List of service request numbers</a> and do the listed action.                                                                                                                                                                                                                        |
| The system stopped with a 3-digit code operator panel display.                                             | Record SRN 101-xxx (where xxx is the three digits of the code displayed). Look up the SRN in the <a href="#">List of service request numbers</a> and do the listed action.                                                                                                                                                                                                                                                                                                                                                                                                                       |
| <b>System Automatically Reboots</b>                                                                        |                                                                                                                                                                                                                                                                                                                                                                                                                                                                                                                                                                                                  |
| System automatically reboots.                                                                              | <ol style="list-style-type: none"> <li>1. Turn off the system unit power.</li> <li>2. Turn on the system unit power and boot from a removable media device, disk, or LAN in service mode.</li> <li>3. Run the diagnostics in problem determination mode.</li> <li>4. Select the All Resources option from the Resource Selection menu to test all resources.</li> <li>5. If an SRN displays, look up the SRN in the <a href="#">List of service request numbers</a> and do the listed action.</li> <li>6. If an SRN is not displayed, suspect a power supply or power source problem.</li> </ol> |
| <b>System does not Reboot When Reset Button is Pushed</b>                                                  |                                                                                                                                                                                                                                                                                                                                                                                                                                                                                                                                                                                                  |
| System does not reboot (reset) when the reset button is pushed.                                            | Record SRN 111-999. Look up the SRN in the <a href="#">List of service request numbers</a> and do the listed action.                                                                                                                                                                                                                                                                                                                                                                                                                                                                             |
| <b>ASYNC Communication Problems</b>                                                                        |                                                                                                                                                                                                                                                                                                                                                                                                                                                                                                                                                                                                  |
| You suspect an async communication problem.                                                                | <ol style="list-style-type: none"> <li>1. Run the advanced async diagnostics on the ports on which you are having problems. If an SRN is displayed, look up the SRN in the <a href="#">List of service request numbers</a> and do the listed</li> </ol>                                                                                                                                                                                                                                                                                                                                          |

|                                                                                                                                                                                                                                                                                                                                                                                                                                                                                                                                                      |                                                                                                                                                                                                                                                                                                                                                                                                                                                                                                                                                                                                                                                                                                                                                                                                                                                                                                                                                                                                                                                                   |
|------------------------------------------------------------------------------------------------------------------------------------------------------------------------------------------------------------------------------------------------------------------------------------------------------------------------------------------------------------------------------------------------------------------------------------------------------------------------------------------------------------------------------------------------------|-------------------------------------------------------------------------------------------------------------------------------------------------------------------------------------------------------------------------------------------------------------------------------------------------------------------------------------------------------------------------------------------------------------------------------------------------------------------------------------------------------------------------------------------------------------------------------------------------------------------------------------------------------------------------------------------------------------------------------------------------------------------------------------------------------------------------------------------------------------------------------------------------------------------------------------------------------------------------------------------------------------------------------------------------------------------|
|                                                                                                                                                                                                                                                                                                                                                                                                                                                                                                                                                      | <p>action.</p> <ol style="list-style-type: none"> <li>If you suspect a problem with the async concentrator, remote async node, and so on, refer to the documentation in <i>Devices, and Cable Information for Multiple Bus Systems</i> on these devices and perform any tests or checks listed.</li> </ol>                                                                                                                                                                                                                                                                                                                                                                                                                                                                                                                                                                                                                                                                                                                                                        |
| <b>SCSI Adapter Problems</b>                                                                                                                                                                                                                                                                                                                                                                                                                                                                                                                         |                                                                                                                                                                                                                                                                                                                                                                                                                                                                                                                                                                                                                                                                                                                                                                                                                                                                                                                                                                                                                                                                   |
| <p>You suspect a SCSI adapter problem.</p> <p>SCSI adapter diagnostics can only be run on a SCSI adapter that was not used for booting. The POST tests any SCSI adapter before attempting to use it for booting. If the system was able to boot using a SCSI adapter, then the adapter is most likely good.</p> <p>SCSI adapters problems are also logged into the error log and are analyzed when the online SCSI diagnostics are run in problem determination mode. Problems are reported if the number of errors is above defined thresholds.</p> | <ol style="list-style-type: none"> <li>Run the online SCSI adapter diagnostic in problem determination mode. If an SRN is displayed, look up the SRN in the <a href="#">List of service request numbers</a> and do the listed action.</li> <li>Use <a href="#">MAP 0050: SCSI bus problems</a>.</li> </ol> <p><b>Note:</b> If you cannot load diagnostics (standalone or online) go to <a href="#">PFW1540: Problem isolation procedures</a>.</p>                                                                                                                                                                                                                                                                                                                                                                                                                                                                                                                                                                                                                 |
| <b>SCSI Bus Problems</b>                                                                                                                                                                                                                                                                                                                                                                                                                                                                                                                             |                                                                                                                                                                                                                                                                                                                                                                                                                                                                                                                                                                                                                                                                                                                                                                                                                                                                                                                                                                                                                                                                   |
| <p>You suspect a SCSI bus problem.</p>                                                                                                                                                                                                                                                                                                                                                                                                                                                                                                               | <ol style="list-style-type: none"> <li>Use <a href="#">MAP 0050: SCSI bus problems</a>.</li> <li>Use the <a href="#">SCSI Bus Service Aid</a> to exercise and test the SCSI Bus.</li> </ol>                                                                                                                                                                                                                                                                                                                                                                                                                                                                                                                                                                                                                                                                                                                                                                                                                                                                       |
| <b>Tape Drive Problems</b>                                                                                                                                                                                                                                                                                                                                                                                                                                                                                                                           |                                                                                                                                                                                                                                                                                                                                                                                                                                                                                                                                                                                                                                                                                                                                                                                                                                                                                                                                                                                                                                                                   |
| <p>You suspect a tape drive problem.</p>                                                                                                                                                                                                                                                                                                                                                                                                                                                                                                             | <ol style="list-style-type: none"> <li>Refer to the tape drive documentation and clean the tape drive.</li> <li>Refer to the tape drive documentation and do any listed problem determination procedures.</li> <li>Run the online advanced tape diagnostics in problem determination mode. If an SRN is displayed, look up the SRN in the <a href="#">List of service request numbers</a> and do the listed action.</li> <li>Use the <a href="#">Backup and restore service aid</a> to exercise and test the drive and media.</li> <li>Use <a href="#">MAP 0050: SCSI bus problems</a>.</li> <li>Use the SCSI bus service aid to exercise and test the SCSI bus.</li> <li>Refer to the device section of <i>Devices, and Cable Information for Multiple Bus Systems</i> for additional information and <a href="#">MAP 0020: Problem determination procedure</a> for problem determination procedures.</li> </ol> <p><b>Note:</b> Information on tape cleaning and tape-problem determination can be found in <a href="#">Tape unit isolation procedures</a>.</p> |
| <b>Optical Drive Problems</b>                                                                                                                                                                                                                                                                                                                                                                                                                                                                                                                        |                                                                                                                                                                                                                                                                                                                                                                                                                                                                                                                                                                                                                                                                                                                                                                                                                                                                                                                                                                                                                                                                   |
| <p>You suspect a optical drive problem.</p>                                                                                                                                                                                                                                                                                                                                                                                                                                                                                                          | <ol style="list-style-type: none"> <li>Perform the problem determination procedures in the optical drive documentation.</li> </ol>                                                                                                                                                                                                                                                                                                                                                                                                                                                                                                                                                                                                                                                                                                                                                                                                                                                                                                                                |

|                                                                                                                                                                                                                                                                                                                                                                                                                                                                                                                                                                                                              |                                                                                                                                                                                                                                                                                                                                                                                                                                                                                                                                                                                                                                                                                                                                                                                                                                                                                                                                                                               |
|--------------------------------------------------------------------------------------------------------------------------------------------------------------------------------------------------------------------------------------------------------------------------------------------------------------------------------------------------------------------------------------------------------------------------------------------------------------------------------------------------------------------------------------------------------------------------------------------------------------|-------------------------------------------------------------------------------------------------------------------------------------------------------------------------------------------------------------------------------------------------------------------------------------------------------------------------------------------------------------------------------------------------------------------------------------------------------------------------------------------------------------------------------------------------------------------------------------------------------------------------------------------------------------------------------------------------------------------------------------------------------------------------------------------------------------------------------------------------------------------------------------------------------------------------------------------------------------------------------|
|                                                                                                                                                                                                                                                                                                                                                                                                                                                                                                                                                                                                              | <ol style="list-style-type: none"> <li>2. Before servicing a optical drive ensure that it is not in use and that the power connector is correctly attached to the drive. If the load or unload operation does not function, replace the optical drive.</li> <li>3. Run the online advanced optical diagnostics in problem determination mode. If an SRN is displayed, look up the SRN in the <a href="#">List of service request numbers</a> and do the listed action.</li> <li>4. If the problem is with a SCSI optical drive, use <a href="#">MAP 0050: SCSI bus problems</a>.</li> <li>5. If the problem is with a SCSI optical drive, use the <a href="#">SCSI bus service aid</a> to exercise and test the SCSI bus.</li> <li>6. Refer to the device section of <i>Devices, and Cable Information for Multiple Bus Systems</i> for additional information and <a href="#">MAP 0020: Problem determination procedure</a> for problem determination procedures.</li> </ol> |
| <b>SCSI Disk Drive Problems</b>                                                                                                                                                                                                                                                                                                                                                                                                                                                                                                                                                                              |                                                                                                                                                                                                                                                                                                                                                                                                                                                                                                                                                                                                                                                                                                                                                                                                                                                                                                                                                                               |
| <p>You suspect a disk drive problem.</p> <p>Disk problems are logged in the error log and are analyzed when the online disk diagnostics are run in problem determination mode. Problems are reported if the number of errors is above defined thresholds.</p> <p>If the diagnostics are booted from a disk, then the diagnostics can only be run on those drives that are not part of the root volume group. However, error log analysis is run if these drives are selected. To run the disk diagnostic tests on disks that are part of the root volume group, the standalone diagnostics must be used.</p> | <ol style="list-style-type: none"> <li>1. Run the online advanced disk diagnostics in problem determination mode. If an SRN is displayed, look up the SRN in the <a href="#">List of service request numbers</a> and do the listed action.</li> <li>2. Run standalone disk diagnostics. If an SRN is displayed, look up the SRN in the <a href="#">List of service request numbers</a> and do the listed action.</li> <li>3. Use the <a href="#">certify disk service aid</a> to verify that the disk can be read.</li> <li>4. Use <a href="#">MAP 0050: SCSI bus problems</a>.</li> <li>5. Use the <a href="#">SCSI bus service aid</a> to exercise and test the SCSI Bus.</li> <li>6. Refer to the device section of <i>Devices, and Cable Information for Multiple Bus Systems</i> for additional information and <a href="#">MAP 0020: Problem determination procedure</a> for problem determination procedures.</li> </ol>                                               |
| <p>Identify LED does not function on the drive plugged into the SES or SAF-TE backplane.</p>                                                                                                                                                                                                                                                                                                                                                                                                                                                                                                                 | <p>Use the "identify a device attached to a SES device" service aid listed under <a href="#">SCSI and SCSI RAID Hot-Plug Manager</a> on the suspect drive LED. If the drive LED does not blink when put into the identify state, use FFC 2D00 and SRN source code "B" and go to <a href="#">MAP 0210: General problem resolution</a>.</p>                                                                                                                                                                                                                                                                                                                                                                                                                                                                                                                                                                                                                                     |
| <p>Activity LED does not function on the drive plugged into the SES or SAF-TE backplane.</p>                                                                                                                                                                                                                                                                                                                                                                                                                                                                                                                 | <p>Use the <a href="#">certify media service aid</a> (see <a href="#">certify media</a>) on the drive in the slot containing the suspect activity LED. If the activity LED does not intermittently blink when running certify, use FFC 2D00 and SRN source code "B" and go to <a href="#">MAP 0210: General problem resolution</a>.</p>                                                                                                                                                                                                                                                                                                                                                                                                                                                                                                                                                                                                                                       |
| <b>Diskette Drive Problems</b>                                                                                                                                                                                                                                                                                                                                                                                                                                                                                                                                                                               |                                                                                                                                                                                                                                                                                                                                                                                                                                                                                                                                                                                                                                                                                                                                                                                                                                                                                                                                                                               |
| <p>You suspect a diskette drive problem.</p>                                                                                                                                                                                                                                                                                                                                                                                                                                                                                                                                                                 | <ol style="list-style-type: none"> <li>1. Run the diskette drive diagnostics. If an SRN is displayed, look up the SRN in the <a href="#">List of service request numbers</a> and do the listed action.</li> <li>2. Use the diskette media service aid to test the diskette media.</li> <li>3. Use the <a href="#">backup/restore media service aid</a> to exercise and test the drive and media.</li> </ol>                                                                                                                                                                                                                                                                                                                                                                                                                                                                                                                                                                   |
| <b>Token-Ring Problems</b>                                                                                                                                                                                                                                                                                                                                                                                                                                                                                                                                                                                   |                                                                                                                                                                                                                                                                                                                                                                                                                                                                                                                                                                                                                                                                                                                                                                                                                                                                                                                                                                               |

|                                                      |                                                                                                                                                                                                                                                                                                                                                                                                                                                                                                                                                                                                                                                                                                                                                                                                                                                                                                                                                                                                                                |
|------------------------------------------------------|--------------------------------------------------------------------------------------------------------------------------------------------------------------------------------------------------------------------------------------------------------------------------------------------------------------------------------------------------------------------------------------------------------------------------------------------------------------------------------------------------------------------------------------------------------------------------------------------------------------------------------------------------------------------------------------------------------------------------------------------------------------------------------------------------------------------------------------------------------------------------------------------------------------------------------------------------------------------------------------------------------------------------------|
| You suspect a token-ring adapter or network problem. | <ol style="list-style-type: none"> <li>1. Run the online advanced token-ring diagnostics in problem determination mode. If an SRN is displayed, look up the SRN in the <a href="#">List of service request numbers</a> and do the listed action.</li> <li>2. Use the ping command to exercise and test the network.</li> <li>3. Refer to <a href="#">MAP 0020: Problem determination procedure</a> for additional information and problem determination procedures.</li> </ol>                                                                                                                                                                                                                                                                                                                                                                                                                                                                                                                                                 |
| <b>Ethernet Problems</b>                             |                                                                                                                                                                                                                                                                                                                                                                                                                                                                                                                                                                                                                                                                                                                                                                                                                                                                                                                                                                                                                                |
| You suspect an Ethernet adapter or network problem.  | <ol style="list-style-type: none"> <li>1. Run the online advanced Ethernet diagnostics in problem determination mode. If an SRN is displayed, look up the SRN in the <a href="#">List of service request numbers</a> and do the listed action.</li> <li>2. Use the ping command to exercise and test the network.</li> <li>3. Refer to <a href="#">MAP 0020: Problem determination procedure</a> for additional information and problem determination procedures.</li> </ol>                                                                                                                                                                                                                                                                                                                                                                                                                                                                                                                                                   |
| <b>Display Problems</b>                              |                                                                                                                                                                                                                                                                                                                                                                                                                                                                                                                                                                                                                                                                                                                                                                                                                                                                                                                                                                                                                                |
| You suspect a display problem.                       | <ol style="list-style-type: none"> <li>1. If your display is connected to a KVM switch, go to <a href="#">Troubleshooting the keyboard, video, and mouse (KVM) switch for the 1x8 and 2x8 console manager</a>. If you are still having display problems after performing the KVM switch procedures, come back here and continue with step 2.</li> <li>2. If you are using the Hardware Management Console, go to the <a href="#">Managing your server using the Hardware Management Console</a> section.</li> <li>3. If you are using a graphics display: <ol style="list-style-type: none"> <li>a. Go to the problem determination procedures for the display.</li> <li>b. If you do not find a problem: <ul style="list-style-type: none"> <li>◇ Replace the graphics display adapter. Refer to <a href="#">Removing and replacing parts</a>.</li> <li>◇ Replace the backplane into which the graphics display adapter is plugged. Refer to <a href="#">Removing and replacing parts</a>.</li> </ul> </li> </ol> </li> </ol> |
| <b>Keyboard or Mouse</b>                             |                                                                                                                                                                                                                                                                                                                                                                                                                                                                                                                                                                                                                                                                                                                                                                                                                                                                                                                                                                                                                                |
| You suspect a keyboard or mouse problem.             | <p>If your keyboard is connected to a KVM switch, go to <a href="#">Troubleshooting the keyboard, video, and mouse (KVM) switch for the 1x8 and 2x8 console manager</a>. If you are still having keyboard problems after performing the KVM switch procedures, come back here and continue to the next paragraph.</p> <p>Run the device diagnostics. If an SRN is displayed, look up the SRN in the <a href="#">List of service request numbers</a> and do the listed action.</p> <p>If you are unable to run diagnostics because the system does not respond to the keyboard, replace the keyboard or system planar.</p>                                                                                                                                                                                                                                                                                                                                                                                                      |

|                                                                                                                                                                                                                                                                                                                                                                                                                                                                                   |                                                                                                                                                                                                                                                                                                                                                                                                                                                                                                                                                                                                                                                                                                      |
|-----------------------------------------------------------------------------------------------------------------------------------------------------------------------------------------------------------------------------------------------------------------------------------------------------------------------------------------------------------------------------------------------------------------------------------------------------------------------------------|------------------------------------------------------------------------------------------------------------------------------------------------------------------------------------------------------------------------------------------------------------------------------------------------------------------------------------------------------------------------------------------------------------------------------------------------------------------------------------------------------------------------------------------------------------------------------------------------------------------------------------------------------------------------------------------------------|
|                                                                                                                                                                                                                                                                                                                                                                                                                                                                                   | <p><b>Note:</b> If the problem is with the keyboard it could be caused by the mouse device. To check, unplug the mouse and then recheck the keyboard. If the keyboard works, replace the mouse.</p>                                                                                                                                                                                                                                                                                                                                                                                                                                                                                                  |
| <b>Printer and TTY Problems</b>                                                                                                                                                                                                                                                                                                                                                                                                                                                   |                                                                                                                                                                                                                                                                                                                                                                                                                                                                                                                                                                                                                                                                                                      |
| You suspect a TTY terminal or printer problem.                                                                                                                                                                                                                                                                                                                                                                                                                                    | <ol style="list-style-type: none"> <li>1. Go to problem determination procedures for the printer or terminal.</li> <li>2. Check the port that the device is attached to by running diagnostics on the port. If an SRN is displayed, look up the SRN in the <a href="#">List of service request numbers</a> and do the listed action.</li> <li>3. Use the "Testing the Line Printer" procedure in <a href="#">General diagnostic information</a> to test the connection to the printer. If a problem exists, replace the following in the order listed: <ol style="list-style-type: none"> <li>a. Device cable</li> <li>b. Port to which the printer or terminal is connected.</li> </ol> </li> </ol> |
| <b>Other Adapter Problems</b>                                                                                                                                                                                                                                                                                                                                                                                                                                                     |                                                                                                                                                                                                                                                                                                                                                                                                                                                                                                                                                                                                                                                                                                      |
| You suspect a problem on another adapter that is not listed above.                                                                                                                                                                                                                                                                                                                                                                                                                | <ol style="list-style-type: none"> <li>1. Run the online advanced diagnostics in problem determination on the adapter you suspect. If an SRN is displayed, look up the SRN in the <a href="#">List of service request numbers</a> and do the listed action.</li> <li>2. Refer to <a href="#">MAP 0020: Problem determination procedure</a> for additional information and problem determination procedures.</li> </ol>                                                                                                                                                                                                                                                                               |
| <b>System Messages</b>                                                                                                                                                                                                                                                                                                                                                                                                                                                            |                                                                                                                                                                                                                                                                                                                                                                                                                                                                                                                                                                                                                                                                                                      |
| A system message is displayed.                                                                                                                                                                                                                                                                                                                                                                                                                                                    | <ol style="list-style-type: none"> <li>1. If the message describes the cause of the problem, attempt to correct it.</li> <li>2. Look for another symptom to use.</li> </ol>                                                                                                                                                                                                                                                                                                                                                                                                                                                                                                                          |
| <b>Processor and Memory Problems</b>                                                                                                                                                                                                                                                                                                                                                                                                                                              |                                                                                                                                                                                                                                                                                                                                                                                                                                                                                                                                                                                                                                                                                                      |
| <p>You suspect a memory problem.</p> <p>Memory tests are only done during POST. Only problems that prevent the system from booting are reported during POST. All other problems are logged and analyzed when the sysplanar0 option under the advanced diagnostics selection menu is run.</p> <p>System crashes are logged in the AIX error log. The sysplanar0 option under the advanced diagnostic selection menu is run in problem determination mode to analyze the error.</p> | <ol style="list-style-type: none"> <li>1. Power off the system.</li> <li>2. Turn on the system unit power and load the online diagnostics in service mode.</li> <li>3. Run either the sysplanar0 or the Memory option under the advanced diagnostics in problem determination mode.</li> <li>4. If an SRN is displayed, record the SRN and location code.</li> <li>5. Look up the SRN in the <a href="#">List of service request numbers</a> and do the listed action.</li> </ol>                                                                                                                                                                                                                    |
| <b>Degraded Performance or Installed Memory Mismatch</b>                                                                                                                                                                                                                                                                                                                                                                                                                          |                                                                                                                                                                                                                                                                                                                                                                                                                                                                                                                                                                                                                                                                                                      |
| Degraded performance or installed memory mismatch                                                                                                                                                                                                                                                                                                                                                                                                                                 | <p>Degraded performance can be caused by memory problems that cause a reduction in the size of available memory. To verify that the system detected the full complement of installed memory do the following:</p> <ol style="list-style-type: none"> <li>1. From the task selection menu select the Display Resource Attribute.</li> <li>2. From the resource selection menu select one of the listed memory resources.</li> <li>3. Verify the amount of memory listed matches the amount actually installed.</li> </ol>                                                                                                                                                                             |

|                                                                                                                                                                                                                            |                                                                                                                                                                                                                                                                                                                                                                                                                                                                                                                       |
|----------------------------------------------------------------------------------------------------------------------------------------------------------------------------------------------------------------------------|-----------------------------------------------------------------------------------------------------------------------------------------------------------------------------------------------------------------------------------------------------------------------------------------------------------------------------------------------------------------------------------------------------------------------------------------------------------------------------------------------------------------------|
|                                                                                                                                                                                                                            | 4. Use the service processor (ASMI) menus to see if the memory has been removed (garded out of) the system's configuration by the system or an administrator.                                                                                                                                                                                                                                                                                                                                                         |
| <b>Missing Resources</b>                                                                                                                                                                                                   |                                                                                                                                                                                                                                                                                                                                                                                                                                                                                                                       |
| Missing resources                                                                                                                                                                                                          | Use the <a href="#">Display Configuration and Resource List</a> or <a href="#">Vital Product Data (VPD) Service Aid</a> to verify that the resource was configured.<br><br>If an installed resource does not appear, check that it is installed correctly. If you do not find a problem, go to <a href="#">MAP 0020: Problem determination procedure</a> .                                                                                                                                                            |
| <b>Missing Path on MPIO Resource</b>                                                                                                                                                                                       |                                                                                                                                                                                                                                                                                                                                                                                                                                                                                                                       |
| Missing path on MPIO resource                                                                                                                                                                                              | If a path is missing on an MPIO resource, shown as the letter P in front of the resource in the resource listing, go to <a href="#">MAP 0020: Problem determination procedure</a> .                                                                                                                                                                                                                                                                                                                                   |
| <b>System Hangs or Loops When Running the OS or Diagnostics</b>                                                                                                                                                            |                                                                                                                                                                                                                                                                                                                                                                                                                                                                                                                       |
| The system hangs in the same application.                                                                                                                                                                                  | Suspect the application. To check the system: <ol style="list-style-type: none"> <li>1. Power off the system.</li> <li>2. Turn on the system unit power and load the online diagnostics in service mode.</li> <li>3. Select the All Resources option from the resource selection menu to test all resources.</li> <li>4. If an SRN is displayed at anytime, record the SRN and location code.</li> <li>5. Look up the SRN in the <a href="#">List of service request numbers</a> and do the listed action.</li> </ol> |
| The system hangs in various applications.                                                                                                                                                                                  | <ol style="list-style-type: none"> <li>1. Power off the system.</li> <li>2. Turn on system unit power and load the online diagnostics in service mode.</li> <li>3. Select the All Resources option from the resource selection menu to test all resources.</li> <li>4. If an SRN is displayed at anytime, record the SRN and location code.</li> <li>5. Look up the SRN in the <a href="#">List of service request numbers</a> and do the listed action.</li> </ol>                                                   |
| The system hangs when running diagnostics.                                                                                                                                                                                 | Replace the resource that is being tested.                                                                                                                                                                                                                                                                                                                                                                                                                                                                            |
| <b>You Cannot Find the Symptom in This Table</b>                                                                                                                                                                           |                                                                                                                                                                                                                                                                                                                                                                                                                                                                                                                       |
| All other problems.                                                                                                                                                                                                        | Go to <a href="#">MAP 0020: Problem determination procedure</a> .                                                                                                                                                                                                                                                                                                                                                                                                                                                     |
| <b>Exchanged FRUs Did Not Fix the Problem</b>                                                                                                                                                                              |                                                                                                                                                                                                                                                                                                                                                                                                                                                                                                                       |
| A FRU or FRUs you exchanged did not fix the problem.                                                                                                                                                                       | Go to <a href="#">MAP 0020: Problem determination procedure</a> .                                                                                                                                                                                                                                                                                                                                                                                                                                                     |
| <b>RAID Problems</b>                                                                                                                                                                                                       |                                                                                                                                                                                                                                                                                                                                                                                                                                                                                                                       |
| You suspect a problem with a RAID.                                                                                                                                                                                         | A potential problem with a RAID adapter exists. Run diagnostics on the RAID adapter. Refer to the <i>RAID Adapters User's Guide and Maintenance Information</i> or the service guide for the RAID.<br><br>If the RAID adapter is a PCI-X RAID adapter, refer to the <i>PCI-X SCSI RAID Controller Reference Guide for AIX</i> .                                                                                                                                                                                       |
| <b>System Date and Time Problems</b>                                                                                                                                                                                       |                                                                                                                                                                                                                                                                                                                                                                                                                                                                                                                       |
| <ul style="list-style-type: none"> <li>• The system does not retain the calendar date after the system has been booted.</li> <li>• The system does not retain the time of day after the system has been booted.</li> </ul> | <ol style="list-style-type: none"> <li>1. Run the sysplanar0 option under the advanced diagnostics in problem determination mode. If an SRN is reported, record the SRN and location code</li> </ol>                                                                                                                                                                                                                                                                                                                  |



|                                          |                                                                                                                                                                                                                                                        |
|------------------------------------------|--------------------------------------------------------------------------------------------------------------------------------------------------------------------------------------------------------------------------------------------------------|
|                                          | information. Look up the SRN in the <a href="#">List of service request numbers</a> and do the listed action.<br>2. Replace the TOD (NVRAM) battery. If this does not fix the problem, replace the service processor; its location is model-dependent. |
| <b>SSA Problems</b>                      |                                                                                                                                                                                                                                                        |
| You suspect an SSA problem.              | A potential problem with an SSA adapter exists. Run the SSA service aid. To perform a service aid see <a href="#">AIX service aids</a> and follow the instructions.                                                                                    |
| <b>Power Indicator Light is Not On</b>   |                                                                                                                                                                                                                                                        |
| A drawer power indicator is not on.      | Return to <a href="#">Start of call procedure</a> .                                                                                                                                                                                                    |
| <b>System Power Problem</b>              |                                                                                                                                                                                                                                                        |
| The system does not power on.            | Return to <a href="#">Start of call procedure</a> .                                                                                                                                                                                                    |
| The system powers on when it should not. | Return to <a href="#">Start of call procedure</a> .                                                                                                                                                                                                    |

## MAP 0070: 888 sequence in operator panel display

Use this MAP when you receive an 888 sequence on the operator panel display or monitor.

### Purpose of this MAP

An 888 sequence in operator panel display suggests that either a hardware or software problem has been detected and a diagnostic message is ready to be read.

**Note:** The 888 may or may not be flashing on the operator panel display.

- Step 0070-1

Perform the following steps to record the information contained in the 888 sequence message.

1. Wait until the 888 sequence displays.
2. Record, in sequence, every code displayed after the 888. On systems with a 3-digit or a 4-digit operator panel, you may need to press the system's "reset" button to view the additional digits after the 888. Stop recording when the 888 digits reappear.
3. Go to [Step 0070-2](#).

- Step 0070-2

Using the first code that you recorded, use the following list to determine the next step to use.

Type 102

Go to [Step 0070-3](#).

Type 103

Go to [Step 0070-4](#).

- Step 0070-3

A Type 102 message generates when a software or hardware error occurs during system execution of an application. Use the following information to determine the content of the type 102 message. Descriptions of the crash codes and the dump status codes are in [AIX Diagnostic Numbers and Location Codes AIX IPL Progress codes](#).

The message readout sequence is:

102 = Message type RRR = Crash code (the three-digit code that immediately follows the 102) SSS = Dump status code (the three-digit code that immediately follows the Crash code).

Record the crash code and the dump status from the message you recorded in [Step 0070-1](#). For an explanation of the dump status or the crash codes, see [AIX Diagnostic Numbers and Location Codes AIX IPL Progress codes](#).

#### Are there additional codes following the dump status?

No

Go to [Step 0070-5](#).

YES

The message also has a type 103 message included in it. Go to [Step 0070-4](#) to decipher the SRN and field replaceable unit (FRU) information in the Type 103 message.

**Note:** Type 102 messages have no associated SRNs.

#### • Step 0070-4

A type 103 message is generated by the hardware when certain types of hardware errors are detected. Use the following steps and information you recorded in [Step 0070-1](#) to determine the content of the Type 103 message.

The message readout sequence is:

103 = Message type (x)xxx (y)yyy = SRN (where (x)xxx = the three- or four-digit code following the 103 and (y)yyy is the three- or four-digit code following the (x)xxx code).

1. Record the SRN and FRU location codes from the recorded message.
2. Find the SRN in the Service Request Number List and do the indicated action.

**Note:** The only way to recover from an 888 type of halt is to turn off the system unit.

#### • Step 0070-5

Perform the following steps:

1. Turn off the system unit power.
2. Turn on the system unit power, and load the online diagnostics in service mode.
3. Wait until one of the following conditions occurs:
  - ◇ You are able to load the diagnostics to the point where the Diagnostic Mode Selection menu displays.
  - ◇ The system stops with an 888 sequence.
  - ◇ The system appears hung.

#### Is the Diagnostic Mode Selection menu displayed?

No

Go to the [Start-of-call procedure](#).

Yes

Go to [Step 0070-6](#).

#### • Step 0070-6

Run the All Resources options under Advanced Diagnostics in Problem Determination Mode.

#### Was an SRN reported by the diagnostics?

No

This is possibly a software-related 888 sequence. Follow the procedure for reporting a software problem.

Yes

Record the SRN and its location code information. Find the SRN in the SRN Listing and do the indicated action.

---

## MAP 0050: SCSI bus problems

Use this MAP to analyze problems with a SCSI bus.

### Purpose of this MAP

Use this MAP to analyze problems with a SCSI bus.

For additional information about this adapter, see the *Devices, and Cable Information for Multiple Bus Systems*.

### Considerations

- To prevent hardware damage or erroneous diagnostic results from a system with its power turned on, use "PCI hot-plug manager" subtask "replace/remove PCI hot plug adapter" before connecting or disconnecting cables or devices.
- Also, use this MAP for SCSI adapters that are built into system backplanes or I/O backplanes. If this procedure calls for replacing a SCSI adapter and the SCSI adapter is built into the system backplane or I/O backplane, replace the system backplane or I/O backplane as appropriate.
- If the failure is a terminator power failure (SRNs xxx-226, xxx-240, xxx-800), always allow five minutes for the PTC to cool.
- The differential version of the adapter has socket-type terminators to support high-availability. If this is the adapter's configuration, the terminators would have been removed from the adapter. MAP steps requiring the removal of the cable from the adapter are inapplicable, since an adapter that is not terminated always fails diagnostics. Proper SCSI diagnostics require proper termination. If the configuration involves a Y-cable, leave it, with the appropriate terminator, attached to the adapter. Or, place an external differential terminator on the external port.
- If the system uses shared disk-drive hardware or a high-availability configuration, ensure that the other system that is sharing the devices is not using the devices. For additional information concerning high-availability configurations, see [SCSI service hints](#).
- For intermittent problems that cannot be resolved with this MAP, refer to [SCSI service hints](#).
- If the SCSI bus is attached to a RAID subsystem, refer to the RAID subsystem documentation for any problem determination. If the RAID adapter is a PCI-X RAID adapter, refer to the *PCI-X SCSI RAID Controller Reference Guide for AIX*.

Follow the steps in this MAP to isolate a SCSI bus problem.

**Note:** This procedure steps you through a process to systematically remove devices and components from a SCSI bus until a problem or a symptom or problem is eliminated. If you go through the whole procedure you will remove all components of a SCSI bus in the following order:

1. Hot-swap devices
2. Devices that are not hot-swap
3. SCSI Enclosure Services (SES) device or enclosures
4. SCSI cables
5. SCSI adapter

Do the following:

- Step 0050-1

**Have changes been made recently to the SCSI configuration?**

NO

Go to [Step 0050-2](#).

YES

Go to [Step 0050-5](#).

- Step 0050-2

**Are there any hot-swap devices (SCSI disk drives or media devices) controlled by the adapter?**

NO

Go to [Step 0050-3](#).

YES

Go to [Step 0050-11](#).

- Step 0050-3

**Are there any devices other than hot-swappable devices controlled by the adapter?**

NO

Go to [Step 0050-4](#).

YES

Go to [Step 0050-13](#).

- Step 0050-4

**Is an enclosure or drawer that supports hot-swap devices controlled by the adapter?**

NO

Go to [Step 0050-22](#).

YES

Go to [Step 0050-15](#).

- Step 0050-5

This step handles cases where recent changes have been made to the SCSI configuration.

Using the first three digits of the SRN, refer to the FFC listing and determine if the adapter is single-ended or differential.

**Is the adapter a single-ended adapter?**

NO

Go to [Step 0050-6](#).

YES

Go to [Step 0050-7](#).

- Step 0050-6

The adapter's termination jumper settings may be incorrect. Power off the system, and inspect jumper J7. Refer to the "SCSI cabling" section of the *Devices, and Cable Information for Multiple Bus Systems* for the correct jumper settings.

**Are the jumpers correct?**

NO

Go to [Step 0050-8](#).

YES

Go to [Step 0050-9](#).

- Step 0050-7

If the adapter *is not* being used in a high-availability configuration, be sure sockets RN1, RN2, and RN3 are populated.

If the adapter *is* being used in a high-availability configuration, be sure sockets RN1, RN2, and RN3 *are not* populated.

Go to [Step 0050-9](#).

- Step 0050-8

1. Correct the jumper settings and reinstall the adapter and all cables.
2. Power on the system, and run diagnostics in system verification mode on the adapter.

**Did the diagnostic pass?**

NO

Go to [Step 0050-9](#).

YES

Go to [Step 0050-10](#).

## • Step 0050-9

Check for the following problems:

- ◆ Address conflicts between devices.
- ◆ Cabling problems such as, configurations that exceed the maximum cable lengths, missing termination, or excessive termination.

Refer to the *Devices, and Cable Information for Multiple Bus Systems* for more details about supported SCSI cabling.

**Did you find a problem?**

NO

Go to [Step 0050-2](#).

YES

Go to [Step 0050-10](#).

## • Step 0050-10

1. Correct the problem.
2. Power on the system, and run diagnostics in system verification mode on the adapter.

**Did a failure occur?**

NO

Go to [MAP 0410: Repair Checkout](#).

YES

Go to [Step 0050-2](#).

## • Step 0050-11

This step determines if a hot-swap device is causing the failure.

1. Go to [Preparing for a hot-plug SCSI device or cable deconfiguration](#).
2. Disconnect all hot-swap devices attached to the adapter.
3. Go to [After hot-plug SCSI device or cable deconfiguration](#).
4. If the Missing Options menu displays, select the The resource has been turned off, but should remain in the system configuration option for all the devices that were disconnected.
5. Run the diagnostics in system verification mode on the adapter.

**Did a failure occur?**

NO

Go to [Step 0050-12](#).

YES

Go to [Step 0050-3](#).

## • Step 0050-12

Go to [Preparing for a hot-plug SCSI device or cable deconfiguration](#). Reconnect the hot-plug devices one at a time. After reconnecting each device, do the follow:

1. Go to [After hot-plug SCSI device or cable deconfiguration](#).
2. Rerun the diagnostics on the adapter.
3. If the adapter fails, the problem may be with the last device reconnected. Perform these substeps:
  - a. Follow repair procedures for that last device.
  - b. Rerun diagnostics on the adapter.
  - c. If diagnostics fail, replace the SES backplane corresponding to the slot for the device.
  - d. Rerun diagnostics.
  - e. If diagnostics fail, replace the last device.
  - f. Rerun diagnostics on the adapter.
  - g. If diagnostics pass, go to [MAP 0410: Repair Checkout](#). Otherwise, contact your support center.

**Note:** A device problem can cause other devices attached to the same SCSI adapter to go into the defined state. Ask the system administrator to make sure that all

devices attached to the same SCSI adapter as the device that you replaced are in the available state.

4. If no errors occur, the problem could be intermittent. Make a record of the problem. Running the diagnostics for each device on the bus may provide additional information.

- Step 0050-13

This step determines if a device other than a hot-swappable device is causing the failure. Follow these steps:

1. Go to [Preparing for a hot-plug SCSI device or cable deconfiguration](#).
2. Disconnect all devices attached to the adapter (except for the device from which you boot to run diagnostics; you may want to temporarily move this device to another SCSI port while you are trying to find the problem).
3. Go to [After hot-plug SCSI device or cable deconfiguration](#).
4. If the Missing Options menu displays, select the The resource has been turned off, but should remain in the system configuration option for all the devices that were disconnected.
5. Run the diagnostics in system verification mode on the adapter.

**Did a failure occur?**

NO

Go to [Step 0050-14](#).

YES

Go to [Step 0050-4](#).

- Step 0050-14

Reconnect the devices one at time. After reconnecting each device, follow this procedure:

1. Rerun the diagnostics in system verification mode on the adapter.
2. If there is a failure, the problem should be with the last device reconnected. Follow the repair procedures for that device, then go to [MAP 0410: Repair Checkout](#).
3. If no errors occur, the problem could be intermittent. Make a record of the problem. Running the diagnostics for each device on the bus may provide additional information.

- Step 0050-15

This step determines whether the SCSI Enclosure Services (SES) controller, which provides hot-plug capability for SCSI drives in the server, is causing the problem.

**Note:** In most cases the SES controller is integrated on the backplane that is used to connect SCSI devices, for example a disk drive backplane. If your system has hot-plug capability and the SES controller is separate from the SCSI drive backplane, there will be an intermediate card on the SCSI bus between the SCSI adapter and the device or SCSI backplane. You will have to make a visual check to see if there are any intermediate cards on the SCSI bus that is displaying a problem.

**Does a separate SES controller plug into the SCSI device backplane?**

NO

Go to [Step 0050-18](#).

YES

Go to [Step 0050-16](#).

- Step 0050-16

Follow these steps:

1. Power off the system.
2. Remove the intermediate SES controller card. Locate the SES controller part number under [FFC 199](#).
3. Power on the system.
4. If the Missing Options menu displays, select the The resource has been turned off, but should remain in the system configuration option for all the devices that were disconnected.
5. Run the diagnostics in system verification mode on the adapter.

**Did a failure occur?**

NO

Go to [Step 0050-17](#).

YES

Go to [Step 0050-18](#).

- Step 0050-17

Follow these steps:

1. Power off the system.
2. Replace the intermediate SES controller card.
3. Go to [MAP 0410: Repair Checkout](#).

- Step 0050-18

Follow these steps:

1. Go to [Preparing for a hot-plug SCSI device or cable deconfiguration](#).
2. Disconnect all cables attached to the SCSI adapter. For SCSI differential adapters in a high-availability configuration, see [Considerations](#).
3. Go to [After hot-plug SCSI device or cable deconfiguration](#).
4. If the Missing Options menu displays, select the The resource has been turned off, but should remain in the system configuration option for all the devices that were disconnected.
5. Run the diagnostics in system verification mode on the adapter.

**Did a failure occur?**

NO

Go to [Step 0050-19](#).

YES

Replace the adapter, then go to [MAP 0410: Repair Checkout](#).

- Step 0050-19

Follow these steps:

1. Go to [Preparing for a hot-plug SCSI device or cable deconfiguration](#).
2. Reconnect the cables to the adapter.

**Does the SES controller (an intermediated SES controller) plug into the backplane?**

NO

Go to [Step 0050-20](#).

YES

Go to [Step 0050-21](#).

- Step 0050-20

Follow these steps:

1. Replace the SES controller. Locate the intermediate SES controller part number under [FFC 199](#).
2. Power on the system.
3. If the Missing Options menu displays, select the The resource has been turned off, but should remain in the system configuration option for all the devices that were disconnected.
4. Run the diagnostics in system verification mode on the adapter.

**Did a failure occur?**

NO

Go to [MAP 0410: Repair Checkout](#).

YES

Go to [Step 0050-21](#).

- Step 0050-21

One of the cables remaining in the system is defective. Refer to [FFC 199](#) for the cable part numbers. Replace the parts one at a time in the order listed. Follow these steps for each FRU replaced:

1. Rerun the diagnostics for the adapter.
2. If there is any failure, continue with the next FRU.
3. If there is no failure, go to [MAP 0410: Repair Checkout](#).

- Step 0050-22

Follow these steps:

1. Go to [Preparing for a hot-plug SCSI device or cable deconfiguration](#).
2. Disconnect all cables attached to the adapter (except for the cable to the device from which you boot to run diagnostics; you may want to temporarily move this device to another SCSI port while you are trying to find the problem).
3. Go to [After hot-plug SCSI device or cable deconfiguration](#).
4. If the Missing Options menu displays, select the The resource has been turned off, but should remain in the system configuration option for all the devices that were disconnected.
5. Run the diagnostics on the adapter.

**Did a failure occur?**

NO

Go to [Step 0050-23](#).

YES

Replace the adapter, then go to [MAP 0410: Repair Checkout](#).

- Step 0050-23

One of the cables remaining in the system is defective. Refer to [FFC 199](#) for the cable part numbers. Replace the parts one at a time in the order listed. Follow these steps for each FRU replaced:

1. Rerun the diagnostics for the adapter.
2. If there is any failure, continue with the next FRU.
3. If there is no failure, go to [MAP 0410: Repair Checkout](#).

---

## SCSI service hints

Use one or more of the following procedures when servicing SCSI adapter or devices.

### General SCSI Configuration Checks

The following steps apply to all types of SCSI problems:

1. Verify that all SCSI devices on the SCSI bus have a unique address.
2. Verify that all cables are connected securely and that there is proper termination at both ends of the SCSI bus.
3. Verify that the cabling configuration does not exceed the maximum cable length for the adapter in use. Refer to *Devices, and Cable Information for Multiple Bus Systems* for more details on SCSI cabling.
4. Verify that the adapters and devices that you are working with are at the appropriate microcode levels for the customer situation. If you need assistance with microcode issues, contact your service support structure.
5. If there are multiple SCSI adapters on the SCSI bus, verify that the customer is using the appropriate software (such as HACMP or HANFS) to support such an arrangement. If the correct software is not in use, some SCSI errors should be expected when multiple adapters attempt to access the same SCSI device. Also, each adapter should have a unique address.

### High Availability or Multiple SCSI System Checks

If you have a high-availability configuration, or if more than one system is attached to the same SCSI bus, do the following:

1. Verify that the adapters and devices have unique SCSI addresses. The default SCSI adapter address is always 7. If you have more than one adapter on the bus, change the address of at least one adapter. This can be done by using SMIT (SMIT Devices > SCSI Adapter > Change/Show characteristics of an adapter). You must make the changes to the database only, then reboot the system in order for the change to take effect.



**Note:** Diagnostics defaults to using ID 7 (it is recommended that this ID not be used in high availability configurations).

2. If RAID devices such as the 7135 or 7137 are attached, be sure to run the proper diagnostics for the device. If problems occur, contact your service support structure for assistance. If the diagnostics are run incorrectly on these devices, misleading SRNs can result.
3. Diagnostics cannot be run against OEM devices; doing so results in misleading SRNs.
4. Verify that all cables are connected securely and that both ends of the SCSI bus is terminated correctly.
5. Verify that the cabling configuration does not exceed the maximum cable length for the adapter in use. Refer to the SCSI Cabling section in the *Devices, and Cable Information for Multiple Bus Systems* for more details on SCSI cabling issues.
6. Verify that adapter and devices are at the appropriate microcode levels for the customer situation. If you need assistance with microcode issues, contact your service support structure.

#### SCSI-2 Single-Ended Adapter PTC Failure Isolation Procedure

Before replacing a SCSI-2 single-ended adapter, use these procedures to determine if a short-circuit condition exists on the SCSI bus. The same positive temperature coefficient (PTC) resistor is used for both the internal and external buses. The PTC protects the SCSI bus from high currents due to shorts on the cable, terminator, or device. It is unlikely that the PTC can be tripped by a defective adapter. Unless instructed to do so by these procedures, do not replace the adapter because of a tripped PTC resistor.

A fault (short-circuit) causes an increase in PTC resistance and temperature. The increase in resistance causes the PTC to halt current flow. The PTC returns to a low resistive and low temperature state when the fault is removed from the SCSI bus or when the system is turned off. Wait 5 minutes for the PTC resistor to fully cool, then retest.

These procedures determine if the PTC resistor is still tripped and then determine if there is a short somewhere on the SCSI bus.

#### Determining Where to Start

Use the following to determine the adapter configuration and select the proper procedure:

- If there are external cables attached to the adapter, start with the "External Bus PTC Isolation Procedure" for your type adapter. The procedures are found in this chapter.
- If there are no external cables attached, start with the [Internal SCSI-2 Single-Ended Bus PTC Isolation Procedure](#).
- If there is a combination of external and internal cables start with the "External Bus PTC Isolation Procedure" for your type adapter. The procedures are found in this chapter. If this procedure does not resolve the problem, continue with the "Internal Bus PTC Isolation Procedure" for your type adapter. The procedures are found in this chapter.

#### External SCSI-2 Single-Ended Bus PTC Isolation Procedure

Isolate the external SCSI bus PTC fault with the following procedure:

**Note:** The external bus is of single-ended design.

1. Ensure the system power and all externally attached device power is turned off. All testing is accomplished with the power off.
2. Disconnect any internal and external cables from the adapter and remove the adapter from the system.
3. Verify with a digital Ohmmeter that the internal PTC resistor, labeled Z1, (refer to the illustration after Internal SCSI-2 Single-Ended Bus PTC Isolation Procedure, step 3) is cool and in a low resistance state, typically less than 1/2 Ohm. Measuring across, be sure to probe both sides of the PTC where the solder joints and board come together. The polarity of the test leads is not important. If necessary, allow the PTC resistor to cool and measure again.
4. This step determines if there is a short on the adapter. Locate Capacitor C1 and measure the resistance across it by using the following procedure:
  - a. Connect the positive lead to the side of the capacitor where the + is indicated on the board near C1. Be sure to probe at the solder joint where the capacitor and board come together.
  - b. Connect the negative lead to the opposite side of the capacitor marked "GND." Be sure to probe at the solder joint where the capacitor and board come together.
  - c. If there is no short present, then the resistance reading is high, typically hundreds of Ohms.

**Note:** Because this is a measurement across unpowered silicon devices, the reading is a function of the Ohmmeter used.

- ◆ If there is a fault, the resistance reading is low, typically below 10 Ohms. Because there are no cables attached, the fault is on the adapter. Replace the adapter.

**Note:** Some multi-function meters label the leads specifically for voltage measurements. When using this type of meter to measure resistance, the plus lead and negative lead may not be labeled correctly. If you are not sure that your meter leads accurately reflect the polarity for measuring resistance, repeat this step with the leads reversed. If the short circuit is not indicated with the leads reversed, the SCSI bus is not faulted (shorted).

- ◆ If the resistance measured was high, proceed to the next step.
5. Reattach the external cable to the adapter, then do the following:
    - a. Measure across C1 as previously described.
    - b. If the resistance is still high, in this case above 10 Ohms, then there is no apparent cause for a PTC failure from this bus. If there are internal cables attached continue to the [Internal SCSI-2 Single-Ended Bus PTC Isolation Procedure](#).
    - c. If the resistance is less than 10 Ohms, there is a possibility of a fault on the external SCSI bus. Troubleshoot the external SCSI bus by disconnecting devices and terminators. Measure across C1 to determine if the fault has been removed. Replace the failing component. Go to [MAP 0410: Repair checkout](#).

#### External SCSI-2 Single-Ended Bus Probable Tripped PTC Causes

The following list provides some suggestions of things to check when the PTC is tripped:

- A shorted terminator or cable. Check for bent pins on each connector and removable terminator.
- Intermittent PTC failures can be caused by improperly seated cable connectors. Reseat the connector and flex the cable in an attempt to duplicate the fault condition across C1.
- Plugging or unplugging a cable or terminator while the system is turned on (hot plugging).
- A shorted device.
- Differential devices or terminators are attached to the single-ended SCSI bus.

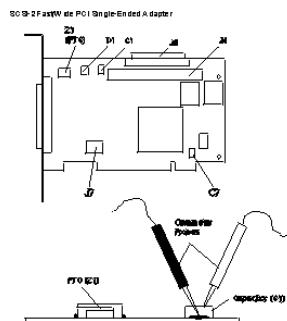
**Note:** The SCSI-2 Fast/Wide and Ultra PCI Adapters use an onboard electronic terminator on the external SCSI bus. When power is removed from the adapter, as in the case of this procedure, the terminator goes to a high impedance state and the resistance measured cannot be verified, other than it is high. Some external terminators use an electronic terminator, which also goes to a high impedance state when power is removed. Therefore, this procedure is designed to find a short or low resistance fault as opposed to the presence of a terminator or a missing terminator.

**Internal SCSI-2 Single-Ended Bus PTC Isolation Procedure**

Isolate the internal SCSI bus PTC resistor fault with the following procedure:

**Note:** The internal bus is single-ended.

1. Ensure that system power and all externally attached device power is turned off.
2. Disconnect any internal and external cables from the adapter then remove the adapter from the system.
3. Verify with a digital Ohmmeter, that the internal PTC resistor, labeled Z1, is cool and in a low resistance state, typically less than 1/2 Ohm. Measuring across, be sure to probe both sides of the PTC where the solder joints and board come together. The polarity of the test leads is not important. If necessary, allow the PTC to cool and measure again. Refer to the following illustration.



**Note:** Only the probe tips are touching the solder joints. Do not allow the probes to touch any other part of the component.

4. This step determines if there is a short on the adapter. Locate capacitor C1 and measure the resistance across it using the following procedure:
  - a. Connect the positive lead to the side of the capacitor where the + is indicated. Be sure to probe at the solder joint where the capacitor and board come together.
  - b. Connect the negative lead to the opposite side of the capacitor. Be sure to probe at the solder joint where the capacitor and board come together.
  - c. If there is no short present, the resistance reading is high, typically hundreds of Ohms.

**Note:** Because this is a measurement across unpowered silicon devices, the reading is a function of the Ohmmeter used.

- ◆ If there is a fault, the resistance reading is low, typically below 10 Ohms. Because there are no cables attached, the fault is on the adapter. Replace the adapter.

**Note:** Some multi-function meters label the leads specifically for voltage measurements. When using this type of meter to measure resistance, the plus lead and negative lead may not be labeled correctly. If you are not sure that your meter leads accurately reflect the polarity for measuring resistance, repeat this step with the leads reversed. Polarity is important in this measurement to prevent forward-biasing diodes which lead to a false low resistance reading. If the short circuit is not indicated with the leads reversed, the SCSI bus is not faulted (shorted).

- ◆ If the resistance is high and there is no internal cable to reattach, there is no apparent cause for the PTC resistor diagnostic failure.
  - ◆ If the resistance is high and there is an internal cable to reattach, proceed to the next step.
5. Reattach the internal cable to the adapter, then do the following:
- a. Measure across C1 as described above.
  - b. If the resistance is still high, above 25 Ohms, there is no apparent cause for a PTC failure.
  - c. If the resistance is less than 10 Ohms, a fault on the internal SCSI bus is possible. Troubleshoot the internal SCSI bus by disconnecting devices and terminators. Measure across C1 to determine if the fault has been removed.

**Note:** Some internal cables have nonremovable terminators.

#### Internal SCSI-2 Single-Ended Bus Probable Tripped PTC Resistor Causes

The following list provides some suggestions of things to check when the PTC is tripped:

- A shorted terminator or cable. Check for bent pins on each connector and removable terminator.
- Intermittent PTC failures can be caused by incorrectly seated cable connectors. Reseat the connector and flex the cable in an attempt to duplicate the fault condition across C1.
- A shorted device.
- On some systems, the terminator is fixed to the internal cable and cannot be removed. If all devices are removed from the cable and the resistance is still low, then the cable should be replaced.

**Note:** The SCSI-2 Fast/Wide and Ultra PCI adapters use an onboard electronic terminator on the internal SCSI bus. When power is removed from the adapter, as in the case of this procedure, the terminator goes to a high impedance state and the resistance measured cannot be verified, other than it is high. Some internal terminators use an electronic terminator, which also goes to a high impedance state when power is removed. Therefore, this procedure is designed to find a short or low resistance fault as opposed to the presence of a terminator or a missing terminator.

#### SCSI-2 Differential Adapter PTC Failure Isolation Procedure

Use this procedure when SRN xxx-240 or xxx-800 has been indicated.

The differential adapter can be identified by the 4-B or 4-L on the external bracket plate.

Before replacing a SCSI-2 differential adapter, use these procedures to determine if a short-circuit condition exists on the SCSI Bus. The PTC protects the SCSI bus from high currents due to shorts on the cable, terminator, or device. It is unlikely that the PTC can be tripped by a defective adapter. Unless instructed to do so by these procedures, do not replace the adapter because of a tripped PTC resistor.

A fault (short-circuit) causes an increase in PTC resistance and temperature. The increase in resistance causes the PTC to halt current flow. The PTC returns to a low resistive and low temperature state when the fault is removed from the SCSI bus or when the system is turned off. Wait 5 minutes for the PTC resistor to fully cool, then retest.

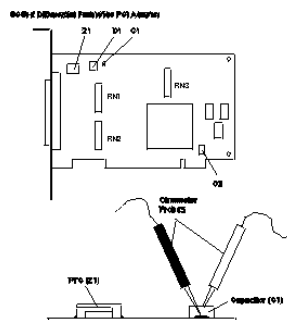
These procedures determine if the PTC resistor is still tripped and then determine if there is a short somewhere on the SCSI bus.

#### External SCSI-2 Differential Adapter Bus PTC Isolation Procedure

Isolate the external SCSI bus PTC fault with the following procedure:

#### Notes:

1. Only the probe tips are touching the solder joints. Do not allow the probes to touch any other part of the component.
  2. The external bus is differential.
1. Ensure that system power and all externally attached device power is turned off.
  2. Check to ensure all devices are marked SCSI Differential and that the terminator on the end of the SCSI bus is also marked differential. If not, you may have a single-ended SCSI device or terminator on the differential SCSI bus. Single-ended devices do not work on a differential SCSI bus and may cause a PTC type error to be reported. The entire SCSI bus may appear to be intermittent. After ensuring the system is completely differential, continue.
  3. Disconnect the external cables from the adapter and remove the adapter from the system.
  4. Verify with a digital Ohmmeter that the internal PTC resistor, labeled Z1, (refer to the illustration on page [External SCSI-2 Differential Adapter Bus PTC Isolation Procedure](#)) is cool and in a low resistance state, typically less than 1/2 Ohm. Measuring across, be sure to probe both sides of the PTC resistor where the solder joints and board come together. The polarity of the test leads is not important. If necessary, allow the PTC resistor to cool and measure again.



5. This step determines if there is a short on the adapter. Locate capacitor C1 and measure the resistance across it using the following procedure:
  - a. Connect the negative lead to the side of the capacitor marked "GND". Be sure to probe at the solder joint where the capacitor and board come together.
  - b. Connect the positive lead to the side of the capacitor marked "Cathode D1" on the board near C1. Be sure to probe at the solder joint where the capacitor and board come together.

- ◇ If there is no fault present, then the resistance reading is 25 to 35 Ohms. The adapter is not faulty. Continue to the next step.
  - ◇ If the resistance measured is higher than 35 Ohms, check to see if RN1, RN2, and RN3 are plugged into their sockets. If these sockets are empty, you are working with a Multi-Initiators or High-Availability system. With these sockets empty, a resistive reading across C1 cannot be verified other than it measures a high resistance (not a short). If the resistance measurement is not low enough to be suspected as a fault (lower than 10 Ohms), continue to the next step.
  - ◇ If the resistance is high and there is no external cable to reattach, there is no apparent cause for the PTC diagnostic failure.
  - ◇ If the resistance reading is low, typically below 10 Ohms, there is a fault. Because there are no cables attached, the fault is on the adapter. Replace the adapter.
  - ◇ If the resistance measured was high and there is an external cable to reattach, proceed to the next step.
6. Reattach the external cable to the adapter.
- a. Measure across C1 as previously described.
  - b. If the resistance is between 10 to 20 Ohms, there is no apparent cause for a PTC resistor failure.
  - c. If the resistance is less than 10 Ohms, there is a possibility of a fault on the external SCSI bus. Troubleshoot the external SCSI bus by disconnecting devices and terminators. Measure across C1 to determine if the fault has been removed.

#### SCSI-2 Differential Adapter Probable Tripped PTC Causes

The following list provides some suggestions of things to check when the PTC is tripped:

- A shorted terminator or cable. Check for bent pins on each connector and removable terminator.
- Intermittent PTC failures can be caused by incorrectly seated cable connectors. Reseat the connector and flex the cable in an attempt to duplicate the fault condition across C1.
- Plugging or unplugging a cable or terminator while the system is turned on (hot-plugging).
- A shorted device.
- Single-ended devices are attached to the differential SCSI bus.

#### Dual-Channel Ultra SCSI Adapter PTC Failure Isolation Procedure

Use the following procedures if diagnostics testing indicates a potential positive temperature coefficient (PTC) resistor fault or the TERMPWR Shorted LED is lit.

This procedure is used for SRNs 637-240 and 637-800 on the Dual-Channel Ultra SCSI Adapter. If the TERMPWR Shorted LED is lit, use this procedure to help isolate the source of the problem on the failing channel.

1. Identify the adapter by its label of 4-R on the external bracket. Then, determine if the failure is on channel A or channel B.
2. The same PTC is used for both the internal and external buses. The PTC protects the SCSI bus from high currents due to shorts on the cable, terminator, or device. It is unlikely that the PTC can be tripped by a defective adapter. A fault (short-circuit) causes an increase in PTC resistance and temperature. The increase in resistance causes the PTC to halt current flow. The PTC returns to a low resistive and low temperature state when the fault is removed from the SCSI bus or when the system is turned off.

Wait 5 minutes for the PTC resistor to fully cool, then retest.

3. If this same error persists, or the TERMPWR Shorted LED is lit, replace the components of the failing channel in the following order (wait five minutes between steps):
  - a. If the failure is on the external cable, replace the following:
    - i. Cable
    - ii. Device

- iii. Attached subsystem
- iv. Adapter
- b. If the failure is on the internal cable, replace the following:
  - i. Cable
  - ii. Device
  - iii. Backplane
  - iv. Adapter
- c. If the failure persists, verify that the parts exchanged are in the correct channel (internal or external, A or B).

If the errors are still occurring, continue isolating the problem by going to [MAP 0050: SCSI bus problems](#).

#### 64-bit PCI-X Dual Channel SCSI Adapter PTC Failure Isolation Procedure

Use the following procedures if diagnostics testing indicates a potential self-resetting thermal fuse problem. This procedure is used for SRN 2524-702 on the integrated dual-channel SCSI adapter in a 396/51 system.

1. Identify the adapter as the one embedded in the system board. Then, determine if the failure is on channel 0 or channel 1.
2. The thermal fuse protects the SCSI bus from high currents due to shorts on the terminator, cable, or device. It is unlikely that the thermal fuse can be tripped by a defective adapter. A fault (short-circuit) causes an increase in resistance and temperature of the thermal fuse. The increase in temperature causes the thermal fuse to halt current flow. The thermal fuse returns to a low resistive and low temperature state when the fault is removed from the SCSI bus or when the system is turned off.

Wait 10 seconds for the thermal fuse to reset itself and recover, then retest.

3. If the same error persists, replace the components of the failing channel in the following order. Wait 10 seconds for the thermal fuse to reset itself between steps.
  - a. Cable
  - b. Device
  - c. DASD backplane (if present)
  - d. System board (adapter)
4. If the failure persists, verify that the parts exchanged are in the correct channel (0 or 1). If the errors are still occurring, continue isolating the problem by going to [MAP 0050: SCSI bus problems](#).

---

## Preparing for hot-plug SCSI device or cable deconfiguration

Use this procedure when you are preparing to deconfigure a hot-plug SCSI device or cable. This procedure will help determine if a SCSI device or SCSI device cable is causing your system problem.

#### Purpose of this procedure

Use this procedure to determine if a SCSI device or SCSI device cable is causing the symptom.

Disconnect all cables attached to the adapter, (except for the cable to the device from which you boot to run diagnostics; you may want to temporarily move this device to another SCSI port while you are trying to find the problem).

**Note:** Move this device to another SCSI port while you are trying to find the problem.

1. Go to [Loading and Using the AIX online diagnostics or the standalone diagnostics](#) and perform the prerequisite tasks described in the "Before you begin" topic.
2. Determine which SCSI adapter you plan to remove the cables or devices from.
3. Adapter slots are numbered on the rear of the system unit, record the slot number and location of each adapter being removed.
4. Ensure that any processes or applications that might use the adapter are stopped.
5. Enter the system diagnostics by logging in as "root" user or as the "celogin" user. Type the diag command on the AIX command line.
6. When the "DIAGNOSTIC OPERATING INSTRUCTIONS" menu displays, press Enter. The "FUNCTION SELECTION" menu appears.
7. From the "FUNCTION SELECTION" menu, select "Task Selection", then press Enter.
8. From the "Task Selection" list, select "PCI Hot Plug Manager".
9. From the PCI Hot Plug Manager menu, select "Unconfigure a Device", then press Enter.
10. Press F4 or ESC 4 to display the "Device Names" menu.
11. Select the adapter from which you are removing the cables or devices in the "Device Names" menu.
12. In the "Keep Definition" field, use the tab key to answer "Yes".
13. In the "Unconfigure Child Devices" field, use the Tab key to answer "Yes", then press Enter.
14. The "ARE YOU SURE" screen displays. Press Enter to verify the information. A successful deconfiguration is indicated by the "OK" message displayed next to the Command field at the top of the screen.
15. Press F4 or ESC 4 twice to return to the "Hot Plug Manager" menu.
16. Select "replace/remove PCI Hot Plug adapter".
17. Select the slot that has the adapter you want to remove the cables or devices from in the system.
18. Select "remove".

**Note:** A fast blinking amber LED located at the back of the machine near the adapter indicates that the slot has been identified.

19. Press Enter. This places the adapter in the "action" state, meaning it is ready to be removed from the system. (Don't need to remove the adapter, unless it makes removing the cables attached to it easier).

---

## After hot-plug SCSI device or cable deconfiguration

Use this procedure after you deconfigure or hot-plug a SCSI device to ensure that the replaced component was successfully installed.

1. Press Enter, then continue to follow the screen instructions until you receive a message that the replacement is successful. A successful replacement is indicated by the OK message displayed next to the command field at the top of the screen.
  2. Press the F3 or ESC 3 key to return to the PCI Hot-Plug Manager menu.
  3. Press the F3 or ESC 3 key to return to the TASK selection list.
  4. Select "Log Repair Action".
  5. Select the adapter you just removed the cables or devices from, then press Enter.
  6. Press Commit (F7 or ESC 7), then press Enter.
  7. Press the F10 or the ESC 0 key to exit diagnostics.
  8. Type the diag -a command on the command line.
- 

## General problem resolution

Use this procedure to exchange the FRUs in the order of their failure probability.

- Step 0210-1

Did the problem report provide a part number for the FRU you are about to replace?

NO

Go to [Step 0210-2](#).



YES

Go to [Step 0210-3](#).

- Step 0210-2

Find the failing function codes in the [System parts](#), and record the FRU part number and description of each FRU.

- Step 0210-3

Obtain the replacement part.

- Step 0210-4

Go to [Removing and replacing parts](#), and follow the procedures for the FRU you are servicing.

---

## General AIX diagnostic information

Information in this section is common to all system units. Any service information or diagnostic procedure that is specific to a certain system unit or device is in the operator guide or service guide for that system unit or device.

### AIX Operating System Message Files

English is the default language displayed by the diagnostic programs when run from disk. If you want to run the diagnostic programs in a language other than English you must install on the system the AIX operating system message locale fileset for the desired language you want displayed.

### Firmware and Microcode

Detailed scenarios that describe how to identify firmware and microcode levels on your server, and updating firmware and microcode on your server, can be found in [Getting fixes](#).

There are several types of firmware used by the system:

- Power subsystem firmware (if applicable)
- Service power control network (SPCN) firmware (if applicable)
- Service processor firmware (if applicable)
- System firmware

The following types of microcode are used by the system:

- Adapter microcode
- Device microcode

If an HMC is attached to the server, the HMC should be used to manage the server's firmware and microcode levels. To manage the server's firmware and microcode levels using the HMC GUI, see [HMC graphical user interface](#).

If an HMC is not attached to the server, AIX diagnostic tasks can be used to display device and adapter microcode levels as well as update device and adapter microcode. AIX diagnostic tasks also provide the capability to update firmware.

To determine the level of server firmware, and device and adapter microcode, use the [Display Microcode Level](#) task in AIX diagnostic service aids. This task presents a list of resources that are currently installed and supported by this task; you then select the resource whose microcode level you wish to check. The `lsmcode` command and the `diag` command can also be used to display the firmware and microcode levels of individual entities in the system from the AIX command line; for additional information, refer to [Display Microcode Level](#). For adapters and devices not supported by this task, refer to the manufacturer's instructions to determine the microcode levels.

Use the [Update and manage system flash](#) task to update a server's firmware. When the flash update is complete, the server automatically reboots. Refer to [Getting fixes](#) for detailed scenarios that explain how to use the update and manage system flash task.

Use the Download microcode service aid on systems running AIX 5.2.0.30 or later to update the microcode on adapters and devices. For details on updating adapter and device microcode, refer to [Getting fixes](#).

For systems that are running only Linux, the stand-alone diagnostics booted from CD-ROM or a NIM server contain service aids that can be used to update most system flash, adapter and device microcode.

## CEREADME File

A CEREADME (CE readme) file is available on all diagnostic media. This file may contain information such as:

- Errata information for the service guides
- Service hints for problems
- Diagnostic information that may not be included in service guides
- Other pertinent (usually release-specific) information

The CEREADME file is helpful in describing differences in diagnostics between the current version and the preceding version.

You can view the CEREADME file by using the Service Hints service aid after the diagnostics are loaded. Also, you can read the file directly from the disk using the AIX `pg` command to display `/usr/lpp/diagnostics/CEREADME`. The CEREADME file can be copied or printed using the normal commands. For information about using the service hints, refer to [Display Service Hints](#).

## Printing the CEREADME file from disk

You can print the CEREADME file from disk using the `cat` command. The path to this file is as follows:  
`/usr/lpp/diagnostics/CEREADME`

A copy of this file should be printed and stored with the Service Information. `lp0` is normally the printer attached to the parallel port. If a printer is attached to the parallel port and is considered as `lp0`, the command for printing the file is as follows:

```
cat /usr/lpp/diagnostics/CEREADME > /dev/lp0
```

## Printing the CEREADME file from a source other than disk

The CEREADME file cannot be printed while diagnostics are being executed from a source other than from the disk. The file can be printed on a system when the AIX operating system is running in a normal user environment. The procedure involves copying the file from the diagnostic media to a temporary file on disk, printing the file, and then deleting the file from disk. Check for directory `/tmp/diag`. To determine if this directory already exists, enter:

```
cd /tmp/diag
```

If the directory does not exist, the message `/tmp/diag: not found` displays. *Do not* attempt to print the CEREADME file if this message is not displayed. To print the CEREADME file, choose the appropriate section below and follow the steps listed.

## Printing the CEREAADME file from CD-ROM

Insert the diagnostic CD-ROM disc into the CD-ROM drive, and then enter the following commands:

```
mkdir /tmp/diag
mount -o ro -v cdrfs /dev/cd0 /tmp/diag
cd /tmp/diag/usr/lpp/diagnostics
cat CEREAADME > /dev/lp0
cd /tmp
umount /dev/cd0
```

The CEREAADME file prints on lp0, which is the printer normally attached to the parallel port. If this file is not the same as the CEREAADME file on the disk, a copy of this file should be printed and stored with the Service Information.

## CE Login

CE login enables a user to perform operating system commands that are required to service the system without being logged in as a root user. CE login must have a role of RunDiagnostics and a primary group of system. This enables the user to:

- Run the diagnostics including the service aids, such as hot plug tasks, certify, format, and so forth.
- Run all the operating system commands run by system group users.
- Configure and unconfigure devices that are not busy.

In addition, CE login can have shutdown group enabled to allow:

- Use of the Update System Microcode service aid.
- Use of shutdown and reboot operations.

To use CE login, ask the customer to create a unique user name and configure these characteristics for that name. (Refer to the Users and Groups section of the *AIX 5L Version 5.1 System Management Guide: Operating System and Devices*.) After this is set up, you will need to obtain the user name and password from the customer to log in with these capabilities. The recommended CE login user name is qserv.

## Automatic diagnostic tests

All automatic diagnostic tests run after the system unit is turned on and before the AIX operating system is loaded.

The automatic diagnostic tests display progress indicators (or checkpoints) to track test progress. If a test stops or hangs, the checkpoint for that test remains in the display to identify the unsuccessful test. The descriptions of these tests are contained in [AIX IPL progress codes](#).

## Power-on self-test

Power-On Self-Test (POST) programs check the devices needed to accomplish an initial program load. The POST also checks the memory, and portions of the central electronics complex, common interrupt handler, and the direct memory access (DMA) handler.

## Configuration program

The configuration program determines the features, adapters, and devices are present on the system. The configuration program, which is part of the AIX operating system, builds a configuration list that is used by the diagnostic programs to control which tests are run during system checkout.

On systems running AIX, the configuration program displays numbers between 2E6 through 9FF and 2300 through 27FF in the operator panel display (if present). Refer to [AIX Diagnostic Numbers and Location Codes](#) and [AIX IPL Progress codes](#) for a listing of program actions associated with displayed numbers. On systems running logical partitions, LPAR displays in the operator panel (if present) after the hypervisor (the system firmware that controls the allocation of resources) is loaded. When a partition running AIX is subsequently booted, the configuration codes display on the virtual operator panel on the HMC.

Devices attached to serial and parallel ports are not configured. The Dials and Lighted Program Function Keys (LPFKs) can be tested from online diagnostics after they are manually configured. No other device attached to the serial and parallel ports is supported by the diagnostics.

## CPU and memory testing and error log analysis

Except for the floating-point tests, all CPU and memory testing on the system units are done by POST and BIST. Memory is tested entirely by the POST. The POST provides an error-free memory MAP. If POST cannot find enough good memory to boot, it halts and displays an error message. If POST finds enough good memory, the memory problems are logged and the system continues to boot.

If any memory errors were logged, they are reported by the base system or memory diagnostics, which must be run to analyze the POST results.

The CPU and memory cannot be tested after the AIX diagnostics are loaded; however, they are monitored for correct operation by various checkers such as processor runtime diagnostics. Exercisers can be run on memory and the floating point unit of the processor to help troubleshoot intermittent problems with those functions (see [Run exercisers](#)). If the threshold value of correctable errors is reached, an error is logged in the error log.

Single-bit memory errors are corrected by ECC (Error Checking and Correction) on systems equipped with ECC memory.

## Diagnostic programs

This section provides overview of the various diagnostic programs.

### Diagnostic controller

The diagnostic controller runs as an application program on the AIX operating system. The diagnostic controller carries out the following functions:

- Displays diagnostic menus
- Checks availability of needed resources
- Checks error log entries under certain conditions
- Loads diagnostic application programs
- Loads task and service aid programs
- Displays test results

To test an adapter or device, select the device or adapter from the diagnostic selection menu. The diagnostic controller then loads the diagnostic application program for the selected device or adapter.

The diagnostic application program loads and runs test units to check the functions of the device or adapter.

The diagnostic controller checks the results of the tests done by the diagnostic application and determines the action needed to continue the testing.

The amount of testing that the diagnostic application does depends on the mode (service, maintenance, or concurrent) under which the diagnostic programs are running.

## Error log analysis

When you select diagnostics or advanced diagnostics, the diagnostic selection menu displays (other menus may display before this menu). This menu allows you to select the purpose for running diagnostics.

When you select the problem determination option, the diagnostic programs read and analyze the contents of the error log.

**Note:** Most hardware errors in the operating system error log contain *sysplanar0* as the resource name. The resource name identifies the resource that detected the error; it does not indicate that the resource is faulty or should be replaced. Use the resource name to determine the appropriate diagnostic to analyze the error.

If the error log contains recent errors (approximately the last 7 days), the diagnostic programs automatically select the diagnostic application program to test the adapter or device that the error was logged against.

If there are no recent errors logged or the diagnostic application program runs without detecting an error, the diagnostic selection menu is displayed. This menu allows you to select a resource for testing.

If an error is detected while the diagnostic application program is running, the A PROBLEM WAS DETECTED screen displays a Service Request Number (SRN).

**Note:** After a FRU is replaced based on an error log analysis program, the error log entries for the problem device must be removed or the program may continue to indicate a problem with the device. To accomplish this task, run the *errclear* command from the command line, or use System Management Interface Tool (SMIT) to select Problem Determination/Error Log/Clear the Error Log. Fill out the appropriate menu items.

## Enhanced FRU isolation

The diagnostics provide enhanced Field Replaceable Unit (FRU) isolation by automatically selecting associated resources. The typical way in which diagnostics select a resource is to present a list of system resources, and you are then asked to select one. Diagnostics begin with that same type of selection.

If the diagnostic application for the selected resource detects a problem with that resource, the diagnostic controller checks for an associated resource. For example, if the test of a disk drive detects a problem, the diagnostic controller tests a sibling device on the same controller to determine if the drive or the controller is failing. This extra FRU isolation is apparent when you test a resource and notice that the diagnostic controller continues to test another resource that you did not select.

## Advanced diagnostics function

The advanced diagnostics function are normally used by a service representative. These diagnostics may ask you to disconnect a cable and install a wrap plug.

The advanced diagnostics run in the same modes as the diagnostics used for normal hardware problem determination. The advanced diagnostics provide additional testing by allowing the service representative to do the following:

- Use wrap plugs for testing.
- Loop on a test (not available in concurrent mode) and display the results of the testing.

## Task and service aid functions

If a device does not show in the test list or you think a device's diagnostic package is not loaded, check by using the display configuration and resource list task. If the device you want to test has a plus (+) sign or a minus (-) sign preceding its name, the diagnostic package is loaded. If the device has an asterisk (\*) preceding its name, the diagnostic package for the device is not loaded or is not available.

Tasks and service aids provide a means to display data, check media, and check functions without being directed by the hardware problem determination procedure. Refer to [AIX tasks and service aids](#) for information and procedures about tasks and service aids.

## System checkout

The system checkout program uses the configuration list generated by the configuration procedure to determine which devices and features to test. These tests run without interaction. To use system checkout, select All Resources on the resource selection menu.

## Missing resource description

In diagnostics version earlier than 5.2.0, missing devices are presented on a missing resource screen. This happens as a result of running `diag -a` or by booting online diagnostics in service mode.

In diagnostics version 5.2.0 and later, missing devices are identified on the diagnostic selection screen by an uppercase **M** preceding the name of the device that is missing. The diagnostic selection menu is displayed anytime you run the diagnostic routines or the advanced diagnostics routines. The diagnostic selection menu can also be entered by running `diag -a` when there are missing devices or missing paths to a device.

When a missing device is selected for processing, the missing resource menu will ask whether the device has been turned off, removed from the system, moved to a different physical location, or if it is still present.

When a single device is missing, the fault is probably with that device. When multiple devices with a common parent are missing, the fault is most likely related to a problem with the parent device.

The diagnostic procedure may include testing the device's parent, analyzing which devices are missing, and any manual procedures that are required to isolate the problem.

## Missing path resolution for MPIO resources

Diagnostics also identifies a multipath I/O device that has multiple configured paths, all of which are missing as a missing device. If some, but not all, paths to a multipath I/O device are missing, then diagnostics identifies those paths as missing. In such an instance, an uppercase **P** displays in front of the multipath I/O

device.

When a device with missing paths is selected from the diagnostic selection menu, the missing path selection menu displays showing the missing paths for the device. The menu requests the user to select a missing path for processing. If the device has only one missing path, then the selection menu is bypassed. In either case, a menu is displayed showing the selected missing path and other available paths to the device (which may be missing or available). The menu asks if the missing path has been removed, has not been removed, or should be ignored. The procedures are as follows:

- If the Path Has Been Removed option is selected, diagnostics removes the path from the data base.
- If the Path Has Not Been Removed option is selected, diagnostics determines why the path is missing.
- If the Run Diagnostics on the Selected Device option is selected, diagnostics runs on the device and does not change the system configuration.

### Periodic diagnostics

Periodic testing of physical processors is enabled by default. If a problem is detected, information about the failure, such as the service request number, is posted to the system console and to the following:

1. If an error notification mailing list has been configured, then information about the failure is sent to the e-mail addresses and system users in this list.
2. If there is an attached HMC, then information about the failure is sent to Service Focal Point.
3. If the mailing list has not been configured and there is not an attached HMC, then information about the failure is sent to all users belonging to the system group.

Periodic diagnostics are controlled by the periodic diagnostic service aid. The periodic diagnostic service aid allows a hardware resource to be tested once a day. If the resource cannot be tested because it is busy, error log analysis is performed if supported on the resource.

In diagnostics versions at or above 5.1.0.15 or 5.2.0.0, periodic diagnostics only supports testing of processors. Disk drives and system boards are no longer supported by periodic diagnostics because testing is not supported in concurrent diagnostics, and coverage is provided by automatic error log analysis.

Processors that are dynamically removed from the system are also removed from the periodic test list. Processors that are dynamically added are automatically added to the periodic test list. Periodic diagnostics does not occur on systems or partitions that have only virtual or shared processors.

### Periodic Diagnostics Reminders

Periodic diagnostic reminders are notifications about failed or deconfigured resources that are reported by firmware to the operating system. Periodic diagnostic reminder mode is run following a successful system boot and then every Tuesday at 8 a.m. Only the resources in the periodic test list are tested for failed or deconfigured status. Adding or removing a resource from the periodic test list enables or disables the periodic diagnostic reminder for that resource.

In diagnostics versions at or above 5.1.0.15 or 5.2.0.0, periodic diagnostic reminder mode is only run for physical processors. Periodic diagnostic reminder mode for processors also performs testing on the processors. If a problem is detected, information about the failure, such as the service request number, is posted to the system console and to the following:

1. If an error notification mailing list has been configured, information about the failure is sent to the email addresses and system users in this list.
2. If there is an attached HMC, then information about the failure is sent to Service Focal Point.
3. If the mailing list has not been configured and there is not an attached HMC, information about the failure is sent to all users belonging to the system group.

Periodic diagnostics reminders do not occur on systems or partitions that have only virtual or shared processors.

## Automatic Error Log Analysis (diagela)

Automatic Error Log Analysis (diagela) provides the capability to perform error log analysis when a permanent hardware error is logged, by enabling the diagela program on all platforms.

The diagela program determines if the error should be analyzed by the diagnostics. If the error should be analyzed, a diagnostic application is invoked and the error is analyzed. No testing is done if the diagnostics determine that the error requires a service action. Instead it sends a message to your console, and either the Service Focal Point for systems with a HMC, or to all system groups. The message contains the SRN.

Running diagnostics in this mode is similar to using the `diag -c -e -d Device` command.

Notification can also be customized by adding a stanza to the PDiagAtt object class. The following example illustrates how a customer's program can be invoked in place of the normal mail message, or in addition to sending the message to the Service Focal Point when there is a HMC:

```
PDiagAtt:
  DClass = " "
  DSClass = " "
  DType = " "
  attribute = "diag_notify"
  value = "/usr/bin/customer_notify_program $1 $2 $3 $4 $5"
  rep = "s"
```

If DClass, DSClass, and DType are blank, then the `customer_notify_program` applies for *all* devices. Filling in the DClass, DSClass, and DType with specifics causes the `customer_notify_program` to be invoked only for that device type.

After the above stanza is added to the ODM data base, problems are displayed on the system console and the program specified in the value field of the `diag_notify` predefined attribute is invoked. The following keyword is expanded automatically as arguments to the notify program:

- \$1 the keyword `diag_notify`
- \$2 the resource name that reported the problem
- \$3 the Service Request Number
- \$4 the device type
- \$5 the error label from the error log entry

In the case where no diagnostic program is found to analyze the error log entry, or analysis is done but no error was reported, a separate program can be specified to be invoked. This is accomplished by adding a stanza to the PDiagAtt object class with an `attribute = diag_analyze`. The following example illustrates how a customer's program can be invoked for this condition:

```
PDiagAtt:
  DClass = " "
  DSClass = " "
  DType= " "
  attribute = "diag_analyze"
  value = "/usr/bin/customer_analyzer_program $1 $2 $3 $4 $5"
  rep = "s"
```

If DClass, DSClass, and DType are blank, then the `customer_analyzer_program` applies for all devices. Filling in the DClass, DSClass, and DType with specifics causes the `customer_analyzer_program` to be invoked only for that device type.

After the above stanza is added to the ODM data base, the program specified is invoked if there is no diagnostic program specified for the error, or if analysis was done, but no error found. The following keywords expand automatically as arguments to the analyzer program:

- \$1 the keyword `diag_analyze`
- \$2 the resource name that reported the problem
- \$3 the error label from the error log entry if from ELA, the keyword PERIODIC if from Periodic Diagnostics, or the keyword REMINDER if from a Diagnostic Reminder.
- \$4 the device type
- \$5 the keywords:



- ◆ no\_trouble\_found if the analyzer was run, but no trouble was found.
- ◆ no\_analyzer if the analyzer is not available.

To activate the automatic error log analysis feature, log in as root user (or use the CE login) and type the following command:

```
/usr/lpp/diagnostics/bin/diagela ENABLE
```

To disable the automatic error log analysis feature, log in as root user (or use the CE login) and type the following command:

```
/usr/lpp/diagnostics/bin/diagela DISABLE
```

The diagela program can also be enabled and disabled using the periodic diagnostic service aid.

## Log repair action

The diagnostics perform error log analysis on most resources. The default time for error log analysis is seven days; however, this time can be changed from 1 to 60 days using the display or change diagnostic run time options task. To prevent false problems from being reported when error log analysis is run, repair actions need to be logged whenever a FRU is replaced. A repair action can be logged by using the log repair action task or by running advanced diagnostics in system verification mode.

The log repair action task lists all resources. Replaced resources can be selected from the list, and when commit (F7 key) is selected, a repair action is logged for each selected resource.

## System fault indicator and system identify indicator

Some systems support the system identify indicator and/or the system fault indicator.

The system identify indicator is used to help physically identify a particular system in a room. The system fault indicator is used to help physically identify a particular system that has a fault condition.

On a system that supports system fault indicator, the indicator is set to fault condition when a fault is detected. After the problem with the system is fixed, the system fault indicator should be set back to normal. This is done by using the log repair action task. For additional information, see [Log repair action](#).

**Note:** This action keeps the system fault indicator from being set to the fault state due to a previous error, that has already been serviced, in the error log.

Both of these indicator functions can be managed by using the system identify indicator and system fault indicator tasks. See [System Fault Indicator](#) or [System Identify Indicator](#) for additional information.

## Array bit steering

An advanced feature of many systems is array bit steering. The processors in these systems have internal cache arrays with extra memory capacity that can be configured to correct certain types of array faults.

This reconfiguration can be used to correct arrays for faults detected at IPL or run time. In the case of a fault detected during run time, the recoverable fault is reported with a "Repair Disposition Pending Reboot" indicator set. This allows diagnostics to call out a service request number that identifies the array and directs the service representative to a MAP for problem resolution that uses array bit steering. If the array bit steering cannot be used for the reported fault, then the FRU with that array is replaced.

### Running diagnostics on the native system port on a full machine partition with a HMC attached

For a full machine partition, the output of the S1 system port is redirected, or wrapped to the virtual console window. When the S1 system port is wrapped, the output of any command is directed from the S1 system port to the virtual console terminal. If you close the virtual console window on the managed system, normal function is restored to the S1 system port.

The implication of this is that the system port wrap diagnostics may fail with a false SRN if the virtual console window on the managed system is not closed. Another method to prevent the false SRN is to unplug the HMC from its port before running the wrap tests.

After running diagnostics on the system port, make sure that the S1 system port is enabled for login (AIX command `chdev -l 'tty'x -a login='enable'` where x is the tty number corresponding to the S1 system port).

### Enhanced I/O error handling

Enhanced I/O Error Handling (EEH) is an error recovery strategy for errors that can occur during I/O operations on the PCI bus. Not all systems support EEH; if you get an SRN involving an EEH error, follow the action listed.

Parent topic: [Working with AIX diagnostics](#)

---

## Linux fast-path problem isolation

Use this information to help you isolate a hardware problem when using the Linux operating system.

### Notes:

1. If the server or partition has an external SCSI disk drive enclosure attached and you have not been able to find a reference code or other symptom, go to [MAP 2010: D24 or T24 START](#)
2. If you are servicing an SP system, go to the Start of Call MAP 100 in the [SP System Service Guide](#).
3. If you are servicing a clustered server that has InfiniBand (IB) switch networks, go to [referenceinfiniband.htm](#) and open the book entitled [Guide to Clustering systems using InfiniBand \(IB\) hardware](#).

## Linux fast path table

Locate the problem in the following table and then go to the action indicated for the problem.

| Symptoms                                                                                    | Action                                                                                                                                                                                                                                                                                                                                                                                                                                                                                                                                                                                                                                                |
|---------------------------------------------------------------------------------------------|-------------------------------------------------------------------------------------------------------------------------------------------------------------------------------------------------------------------------------------------------------------------------------------------------------------------------------------------------------------------------------------------------------------------------------------------------------------------------------------------------------------------------------------------------------------------------------------------------------------------------------------------------------|
| You have an eight-digit reference code.                                                     | Go to <a href="#">Reference codes</a> , read the notes on the first page, and do the listed action for the eight-digit reference code.                                                                                                                                                                                                                                                                                                                                                                                                                                                                                                                |
| You are trying to isolate a problem on a Linux server or a partition that is running Linux. | <p><b>Note:</b> This procedure is used to help display an eight-digit reference code using system log information. Before using this procedure, if you are having a problem with a media device such as a tape or DVD-ROM drive, continue through this table and follow the actions for the appropriate device.</p> <p>Go to <a href="#">Linux problem isolation procedure</a>.</p>                                                                                                                                                                                                                                                                   |
| You suspect a problem with your server but you do not have any specific symptom.            | Go to <a href="#">MAP 0020: Problem determination procedure</a> for problem determination procedures.                                                                                                                                                                                                                                                                                                                                                                                                                                                                                                                                                 |
| You need to run the standalone diagnostics                                                  | Go to <a href="#">Loading the AIX online and standalone diagnostics</a> .                                                                                                                                                                                                                                                                                                                                                                                                                                                                                                                                                                             |
| SRNs                                                                                        |                                                                                                                                                                                                                                                                                                                                                                                                                                                                                                                                                                                                                                                       |
| You have an SRN.                                                                            | Look up the SRN in the <a href="#">List of service request numbers</a> and do the listed action.                                                                                                                                                                                                                                                                                                                                                                                                                                                                                                                                                      |
| An SRN is displayed when running the standalone diagnostics.                                | <ol style="list-style-type: none"> <li>1. Record the SRN and location code.</li> <li>2. Look up the SRN in the <a href="#">List of service request numbers</a> and do the listed action.</li> </ol>                                                                                                                                                                                                                                                                                                                                                                                                                                                   |
| Tape Drive Problems                                                                         |                                                                                                                                                                                                                                                                                                                                                                                                                                                                                                                                                                                                                                                       |
| You suspect a tape drive problem.                                                           | <ol style="list-style-type: none"> <li>1. Refer to the tape drive documentation and clean the tape drive.</li> <li>2. Refer to the tape drive documentation and do any listed problem determination procedures.</li> <li>3. Go to <a href="#">MAP 0020: Problem determination procedure</a> for problem determination procedures.</li> <li>4. Refer to the device section of <i>Devices, and Cable Information for Multiple Bus Systems</i> for additional information (</li> </ol> <p><b>Note:</b> Information on tape cleaning and tape-problem determination is normally either in the tape drive operator guide or the system operator guide.</p> |
| Optical Drive Problems                                                                      |                                                                                                                                                                                                                                                                                                                                                                                                                                                                                                                                                                                                                                                       |
| You suspect an optical drive problem.                                                       | <ol style="list-style-type: none"> <li>1. Refer to the optical documentation and do any listed problem determination procedures.</li> <li>2. Before servicing an optical drive ensure that it is not in use and that the power connector is correctly attached to the drive. If the load or unload operation does not function, replace the optical drive.</li> <li>3. Go to <a href="#">MAP 0020: Problem determination procedure</a> for problem determination procedures.</li> <li>4. Refer to the device section of <i>Devices, and Cable Information for Multiple Bus Systems</i> for additional information (</li> </ol>                        |

|                                                                                                                                                                                                                                                                   |                                                                                                                                                                                                                                                                                                                                                                                                                                                                                                                                                                                                                                                                                                                                                                                                                                                                                                                                                                                                                                |
|-------------------------------------------------------------------------------------------------------------------------------------------------------------------------------------------------------------------------------------------------------------------|--------------------------------------------------------------------------------------------------------------------------------------------------------------------------------------------------------------------------------------------------------------------------------------------------------------------------------------------------------------------------------------------------------------------------------------------------------------------------------------------------------------------------------------------------------------------------------------------------------------------------------------------------------------------------------------------------------------------------------------------------------------------------------------------------------------------------------------------------------------------------------------------------------------------------------------------------------------------------------------------------------------------------------|
|                                                                                                                                                                                                                                                                   | <b>Note:</b> If the optical has its own user documentation, follow any problem determination for the optical drive.                                                                                                                                                                                                                                                                                                                                                                                                                                                                                                                                                                                                                                                                                                                                                                                                                                                                                                            |
| <b>SCSI Disk Drive Problems</b>                                                                                                                                                                                                                                   |                                                                                                                                                                                                                                                                                                                                                                                                                                                                                                                                                                                                                                                                                                                                                                                                                                                                                                                                                                                                                                |
| <p>You suspect a disk drive problem.</p> <p>Disk problems are logged in the error log and are analyzed when the standalone disk diagnostics are run in problem determination mode. Problems are reported if the number of errors is above defined thresholds.</p> | <ol style="list-style-type: none"> <li>1. Go to <a href="#">MAP 0020: Problem determination procedure</a> for problem determination procedures.</li> <li>2. Refer to the device section of <i>Devices, and Cable Information for Multiple Bus Systems</i> for additional information (</li> </ol>                                                                                                                                                                                                                                                                                                                                                                                                                                                                                                                                                                                                                                                                                                                              |
| <b>Diskette Drive Problems</b>                                                                                                                                                                                                                                    |                                                                                                                                                                                                                                                                                                                                                                                                                                                                                                                                                                                                                                                                                                                                                                                                                                                                                                                                                                                                                                |
| <p>You suspect a diskette drive problem.</p>                                                                                                                                                                                                                      | <ol style="list-style-type: none"> <li>1. Go to <a href="#">MAP 0020: Problem determination procedure</a> for problem determination procedures.</li> </ol>                                                                                                                                                                                                                                                                                                                                                                                                                                                                                                                                                                                                                                                                                                                                                                                                                                                                     |
| <b>Token-Ring Problems</b>                                                                                                                                                                                                                                        |                                                                                                                                                                                                                                                                                                                                                                                                                                                                                                                                                                                                                                                                                                                                                                                                                                                                                                                                                                                                                                |
| <p>You suspect a token-ring adapter or network problem.</p>                                                                                                                                                                                                       | <ol style="list-style-type: none"> <li>1. Check with the network administrator for known problems.</li> <li>2. Go to <a href="#">MAP 0020: Problem determination procedure</a> for problem determination procedures.</li> </ol>                                                                                                                                                                                                                                                                                                                                                                                                                                                                                                                                                                                                                                                                                                                                                                                                |
| <b>Ethernet Problems</b>                                                                                                                                                                                                                                          |                                                                                                                                                                                                                                                                                                                                                                                                                                                                                                                                                                                                                                                                                                                                                                                                                                                                                                                                                                                                                                |
| <p>You suspect an Ethernet adapter or network problem.</p>                                                                                                                                                                                                        | <ol style="list-style-type: none"> <li>1. Check with the network administrator for known problems.</li> <li>2. Go to <a href="#">MAP 0020: Problem determination procedure</a> for problem determination procedures.</li> </ol>                                                                                                                                                                                                                                                                                                                                                                                                                                                                                                                                                                                                                                                                                                                                                                                                |
| <b>Display Problems</b>                                                                                                                                                                                                                                           |                                                                                                                                                                                                                                                                                                                                                                                                                                                                                                                                                                                                                                                                                                                                                                                                                                                                                                                                                                                                                                |
| <p>You suspect a display problem.</p>                                                                                                                                                                                                                             | <ol style="list-style-type: none"> <li>1. If your display is connected to a KVM switch, go to <a href="#">Troubleshooting the keyboard, video, and mouse (KVM) switch for the 1x8 and 2x8 console manager</a>. If you are still having display problems after performing the KVM switch procedures, come back here and continue with step 2.</li> <li>2. If you are using the Hardware Management Console, go to the <a href="#">Managing your server using the Hardware Management Console</a> section.</li> <li>3. If you are using a graphics display: <ol style="list-style-type: none"> <li>a. Go to the problem determination procedures for the display.</li> <li>b. If you do not find a problem: <ol style="list-style-type: none"> <li>◇ Replace the graphics display adapter. Refer to <a href="#">Removing and replacing parts</a>.</li> <li>◇ Replace the backplane into which the graphics display adapter is plugged. Refer to <a href="#">Removing and replacing parts</a>.</li> </ol> </li> </ol> </li> </ol> |
| <b>Keyboard or Mouse</b>                                                                                                                                                                                                                                          |                                                                                                                                                                                                                                                                                                                                                                                                                                                                                                                                                                                                                                                                                                                                                                                                                                                                                                                                                                                                                                |
| <p>You suspect a keyboard or mouse problem.</p>                                                                                                                                                                                                                   | <p>If your keyboard is connected to a KVM switch, go to <a href="#">Troubleshooting the keyboard, video, and mouse (KVM) switch for the 1x8 and 2x8 console manager</a>. If you are still having keyboard problems after performing the KVM switch procedures, come back here and continue to the next paragraph.</p> <p>Go to <a href="#">MAP 0020: Problem determination procedure</a> for problem determination procedures.</p> <p>If you are unable to run diagnostics because the system does not respond to the keyboard, replace the keyboard or system planar.</p>                                                                                                                                                                                                                                                                                                                                                                                                                                                     |

|                                                                 |                                                                                                                                                                                                                                                                                                                                                                                                                                                 |
|-----------------------------------------------------------------|-------------------------------------------------------------------------------------------------------------------------------------------------------------------------------------------------------------------------------------------------------------------------------------------------------------------------------------------------------------------------------------------------------------------------------------------------|
|                                                                 | <b>Note:</b> If the problem is with the keyboard it could be caused by the mouse device. To check, unplug the mouse and then recheck the keyboard. If the keyboard works, replace the mouse.                                                                                                                                                                                                                                                    |
| <b>System Messages</b>                                          |                                                                                                                                                                                                                                                                                                                                                                                                                                                 |
| A System Message is displayed.                                  | <ol style="list-style-type: none"> <li>1. If the message describes the cause of the problem, attempt to correct it.</li> <li>2. Look for another symptom to use.</li> </ol>                                                                                                                                                                                                                                                                     |
| <b>System Hangs or Loops When Running the OS or Diagnostics</b> |                                                                                                                                                                                                                                                                                                                                                                                                                                                 |
| The system hangs in the same application.                       | <p>Suspect the application. To check the system:</p> <ol style="list-style-type: none"> <li>1. Power off the system.</li> <li>2. Go to <a href="#">MAP 0020: Problem determination procedure</a> for problem determination procedures.</li> <li>3. If an SRN is displayed at anytime, record the SRN and location code.</li> <li>4. Look up the SRN in the <a href="#">List of service request numbers</a> and do the listed action.</li> </ol> |
| The system hangs in various applications.                       | <ol style="list-style-type: none"> <li>1. Power off the system.</li> <li>2. Go to <a href="#">MAP 0020: Problem determination procedure</a> for problem determination procedures.</li> <li>3. If an SRN is displayed at anytime, record the SRN and location code.</li> <li>4. Look up the SRN in the <a href="#">List of service request numbers</a> and do the listed action.</li> </ol>                                                      |
| The system hangs when running diagnostics.                      | Replace the resource that is being tested.                                                                                                                                                                                                                                                                                                                                                                                                      |
| <b>Exchanged FRUs Did Not Fix the Problem</b>                   |                                                                                                                                                                                                                                                                                                                                                                                                                                                 |
| A FRU or FRUs you exchanged did not fix the problem.            | Go to <a href="#">MAP 0020: Problem determination procedure</a> .                                                                                                                                                                                                                                                                                                                                                                               |
| <b>RAID Problems</b>                                            |                                                                                                                                                                                                                                                                                                                                                                                                                                                 |
| You suspect a problem with a RAID.                              | <p>A potential problem with a RAID adapter exists. Run diagnostics on the RAID adapter. Refer to the <i>RAID Adapters User's Guide and Maintenance Information</i>, refer to</p> <p>If the RAID adapter is a PCI-X RAID adapter, refer to the <i>PCI-X SCSI RAID Controller Reference Guide for AIX</i> in the</p>                                                                                                                              |
| <b>SSA Problems</b>                                             |                                                                                                                                                                                                                                                                                                                                                                                                                                                 |
| You suspect an SSA problem.                                     | A potential problem with an SSA adapter exists. Run diagnostics on the SSA adapter. If the system has external SSA drives, refer to the <i>SSA Adapters User's Guide and Maintenance Information</i> (, or the service guide for your disk subsystem.                                                                                                                                                                                           |
| <b>You Cannot Find the Symptom in This Table</b>                |                                                                                                                                                                                                                                                                                                                                                                                                                                                 |
| All other problems.                                             | Go to <a href="#">MAP 0020: Problem determination procedure</a> .                                                                                                                                                                                                                                                                                                                                                                               |

## HMC isolation procedures

Use this information to diagnose and repair problems that are related to the Hardware Management Console (HMC).

## **DANGER**When working on or around the system, observe the following precautions:

Electrical voltage and current from power, telephone, and communication cables are hazardous. To avoid a shock hazard:

- Connect power to this unit only with the provided power cord. Do not use the provided power cord for any other product.
- Do not open or service any power supply assembly.
- Do not connect or disconnect any cables or perform installation, maintenance, or reconfiguration of this product during an electrical storm.
- The product might be equipped with multiple power cords. To remove all hazardous voltages, disconnect all power cords.
- Connect all power cords to a properly wired and grounded electrical outlet. Ensure that the outlet supplies proper voltage and phase rotation according to the system rating plate.
- Connect any equipment that will be attached to this product to properly wired outlets.
- When possible, use one hand only to connect or disconnect signal cables.
- Never turn on any equipment when there is evidence of fire, water, or structural damage.
- Disconnect the attached power cords, telecommunications systems, networks, and modems before you open the device covers, unless instructed otherwise in the installation and configuration procedures.
- Connect and disconnect cables as described in the following procedures when installing, moving, or opening covers on this product or attached devices.  
To Disconnect:
  1. Turn off everything (unless instructed otherwise).
  2. Remove the power cords from the outlets.
  3. Remove the signal cables from the connectors.
  4. Remove all cables from the devices

To Connect:

1. Turn off everything (unless instructed otherwise).
2. Attach all cables to the devices.
3. Attach the signal cables to the connectors.
4. Attach the power cords to the outlets.
5. Turn on the devices.

(D005)

You should use these procedures if you were directed here from the [Start of call procedure](#). Go to [HMC problem isolation](#).

**Parent topic:** [Isolating problems](#)

---

## **Using failing item codes**

This information is a list of failing item codes.

Reserved.

**Parent topic:** [Isolating problems](#)

---

## **Symbolic FRUs**

This information is a list of symbolic field replaceable units (FRUs).

**DANGER** When working on or around the system, observe the following precautions:

Electrical voltage and current from power, telephone, and communication cables are hazardous. To avoid a shock hazard:

- Connect power to this unit only with the provided power cord. Do not use the provided power cord for any other product.
- Do not open or service any power supply assembly.
- Do not connect or disconnect any cables or perform installation, maintenance, or reconfiguration of this product during an electrical storm.
- The product might be equipped with multiple power cords. To remove all hazardous voltages, disconnect all power cords.
- Connect all power cords to a properly wired and grounded electrical outlet. Ensure that the outlet supplies proper voltage and phase rotation according to the system rating plate.
- Connect any equipment that will be attached to this product to properly wired outlets.
- When possible, use one hand only to connect or disconnect signal cables.
- Never turn on any equipment when there is evidence of fire, water, or structural damage.
- Disconnect the attached power cords, telecommunications systems, networks, and modems before you open the device covers, unless instructed otherwise in the installation and configuration procedures.
- Connect and disconnect cables as described in the following procedures when installing, moving, or opening covers on this product or attached devices.
  - To Disconnect:
    1. Turn off everything (unless instructed otherwise).
    2. Remove the power cords from the outlets.
    3. Remove the signal cables from the connectors.
    4. Remove all cables from the devices

To Connect:

1. Turn off everything (unless instructed otherwise).
2. Attach all cables to the devices.
3. Attach the signal cables to the connectors.
4. Attach the power cords to the outlets.
5. Turn on the devices.

(D005)

The procedures in this topic are listed alphabetically.

thanks

- **ACMODUL**  
Your server has suffered a power loss. This procedure will help you determine the source of the power loss condition that brought you here.
- **AIRMOVR**  
A fan may be failing. Before replacing any field replaceable units (FRUs), verify that all cables are seated correctly.
- **AJDGP01**  
Licensed Internal Code is the failing item. Look for PTFs associated with the reference code and have the customer apply them.
- **AJDG301**  
Licensed Internal Code is the failing item. Look for PTFs associated with the reference code and have the customer apply them.
- **AJEDA00**  
Licensed Internal Code is the failing item. Look for PTFs associated with the reference code and have the customer apply them.
- **AJEGP01**  
Licensed Internal Code is the failing item. Look for PTFs associated with the reference code and have the customer apply them.
- **AJEU00**  
Licensed Internal Code is the failing item. Look for PTFs associated with the reference code and have the customer apply them.

- **AJGAM01**  
Licensed Internal Code is the failing item. Look for PTFs associated with the reference code and have the customer apply them.
- **AJGDF01**  
Licensed Internal Code is the failing item. Look for PTFs associated with the reference code and have the customer apply them.
- **AJGFN00**  
Licensed Internal Code is the failing item. Look for PTFs associated with the reference code and have the customer apply them.
- **AJGJQ01**  
Licensed Internal Code is the failing item. Look for PTFs associated with the reference code and have the customer apply them.
- **AJGLD01**  
Licensed Internal Code is the failing item. Look for PTFs associated with the reference code and have the customer apply them.
- **AJGJ601**  
Licensed Internal Code is the failing item. Look for PTFs associated with the reference code and have the customer apply them.
- **AJGW701**  
Licensed Internal Code is the failing item. Look for PTFs associated with the reference code and have the customer apply them.
- **AJLAF01**  
Licensed Internal Code is the failing item. Look for PTFs associated with the reference code and have the customer apply them.
- **AJLAG01**  
Licensed Internal Code is the failing item. Look for PTFs associated with the reference code and have the customer apply them.
- **AJLYC01**  
Licensed Internal Code is the failing item. Look for PTFs associated with the reference code and have the customer apply them.
- **AJLYD01**  
Licensed Internal Code is the failing item. Look for PTFs associated with the reference code and have the customer apply them.
- **AJSDJ01**  
Licensed Internal Code is the failing item. Look for PTFs associated with the reference code and have the customer apply them.
- **ALTMANL**  
An Integrated server (IXS) for service call may be needed to fix the problem on the IXS.
- **AMBTEMP**  
The system detected a room ambient over-temperature warning or fault.
- **AMBTMP1**  
Ambient air temperature is too high for optimal performance.
- **AMBTMP2**  
Ambient air temperature is back within range.
- **ANYBRDG**  
Find the location of the card reporting the problem and its corresponding PCI bridge set. Any cable, card, or card enclosure not necessarily the card that reported the problem connected to the PCI bridge set may be causing the problem.
- **ANYBUS**  
Any cable, card, or card enclosure may be causing an IOP-detected bus error, although the IOP that is reporting the problem may not be causing the problem.
- **ANYFC**  
Any IOA, hub, gateway, or device attached to the same Fibre Channel interface may be failing.
- **ANYPROC**  
The failing component is one of the system processors.
- **AS4NTDD**  
The Windows server application processor device driver may be causing the problem.
- **AUXCBL**  
Replace the SCSI cable that connects the auxiliary cache I/O adapter to the storage I/O adapter.
- **AUXIOA**  
Replace the auxiliary I/O adapter.
- **BACKPLN**  
A backplane or a connection to the backplane may be failing. Use this procedure to identify which backplane may be failing.
- **BATCHGR**  
A battery power unit charger is the failing item.



- **BATRY**  
The battery may be the failing item.
- **BKPLEXT**  
Use this procedure when replacing the backplane extender on ESCALA PL 850R/PL 1650R/R+, ESCALA PL 3250R, or an ESCALA PL 6450R.
- **BRDGSET**  
The multi-adapter bridge hardware is having a problem with one or more PCI cards or adapters in the PCI bridge set, but the exact card or adapter cannot be identified.
- **BRDGST1**  
The multi-adapter bridge hardware is having a problem with one or more PCI cards or adapters in the first PCI bridge set in the enclosure, but the exact card or adapter cannot be identified.
- **BRDGST2**  
PCI I/O card group in the second PCI bridge set (middle adapter card range when there are three PCI bridge sets and high adapter card range when there are two PCI bridge sets), IOAs and/or IOPs.
- **BRDGST3**  
PCI I/O card group in the third PCI bridge set (highest adapter card range), IOAs and/or IOPs.
- **BPC**  
The Bulk power controller (BPC) may be failing.
- **BPCHANG**  
The system is stopped on one of the base motherboard controller checkpoints.
- **BSTWRPL**  
This symbolic FRU is no longer supported.
- **BUSVPD**  
This is the VPD (vital product data) for a PCI bus at the multi-adapter bridge end of the primary PCI bus.
- **CABLEH**  
Use this information to perform the appropriate action for the SRC you are working with.
- **CACHBAT**  
The cache battery pack may be failing.
- **CACHE**  
This symbolic FRU is no longer supported.
- **CAPACTY**  
The failing component is the VPD card.
- **CARDFLT**  
Use this information to perform the appropriate action for the SRC you are working with.
- **CARDTMP**  
The cryptographic adapter has detected a voltage and/or temperature change in its physical operating environment.
- **CBLLALL**  
A power cable may be the failing item.
- **CBLCONT**  
This symbolic FRU is used to show additional locations for the endpoints of cables.
- **CDAWKLD**  
Too many communications lines are in use.
- **CDTRAY**  
This symbolic FRU is not supported.
- **CHECK**  
Look here for information about the CHECK symbolic FRU.
- **CLCKMOD**  
The logic oscillator is failing.
- **CLRNVRM**  
A problem may exist with the service processor NVRAM.
- **COMPRES1**  
The compressed device and the compression IOA are not compatible.
- **CRYPBAT**  
The batteries for the cryptographic adapter need to be replaced.
- **CTLPNCD**  
This symbolic FRU is not supported on the system. Continue with the next FRU in the failing item list.
- **CTLPNL**  
A control panel or display panel may be failing.
- **DASDBP**  
Use this procedure when determining what DASD backplane to replace on ESCALA PL 250T/R, ESCALA PL 450T/R, or an ESCALA PL 850R/PL 1650R/R+
- **DCA**  
A DCA needs to be replaced.
- **DEVBPLN**  
A device backplane may be failing.

- **DEVICE**  
The addressed storage device is the failing item.
- **DEVTERM**  
The device terminating plug may be failing.
- **DIMM 0**  
Use this topic to view the locations of DIMM 0, DIMM 1, DIMM 2, and DIMM 3 on the 2890 and 2892 Integrated xSeries Server (IXS) cards.
- **DIMMO\_1**  
Use this topic to view the locations of DIMM 0, DIMM 1, DIMM 2, and DIMM 3 on 2892 Integrated xSeries Server (IXS) card.
- **DIMM 1**  
Use this topic to view the locations of DIMM 0, DIMM 1, DIMM 2, and DIMM 3 on the 2890 and 2892 Integrated xSeries Server (IXS) cards.
- **DIMM 2**  
Use this topic to view the locations of DIMM 0, DIMM 1, DIMM 2 and DIMM 3 on the 2890 and 2892 Integrated xSeries Server (IXS) card.
- **DIMM2\_3**  
Use this topic to view the locations of DIMM 0, DIMM 1, DIMM 2 and DIMM 3 on 2892 Integrated xSeries Server (IXS) card.
- **DIMM 3**  
Use this topic to view the locations of DIMM 0, DIMM 1, DIMM 2 and DIMM 3 on the 2890 and 2892 Integrated xSeries Server (IXS) cards.
- **DISKDRV**  
The disk drive and logic card may be failing.
- **DISKFAN**  
A fan in a 57/86 or 57/87 expansion unit might be failing.
- **DISKIMG**  
There may be a problem with the Network Server Description (NWSD).
- **DISKPWR**  
A power supply in a 57/86 or 57/87 expansion unit might be failing.
- **DPAC**  
The two-port adapter cable (part number 21F9345) is the failing item.
- **DRVSWCH**  
The address switches on an optical disk drive in the optical library need to be checked and verified.
- **DSKTRY**  
This symbolic FRU is no longer supported.
- **DSKUNIT**  
DSKUNIT is similar to the symbolic FRU DISKDRV.
- **EACODE**  
An error occurred in the error analysis licensed internal code.
- **EXTREMD**  
An external removable media storage device may be failing.
- **EXTSCSI**  
The external signal cable may be failing.
- **FCCABLE**  
The fibre channel cable may be failing.
- **FCCODE**  
An error has been detected in the fibre channel gateway device licensed internal code.
- **FCDEV**  
The attached fibre channel device or fiber channel gateway device is the failing item.
- **FCGATE**  
The fibre channel gateway device is the failing item.
- **FCINTF**  
An error has been detected on the fibre channel interface.
- **FCIOA**  
The fibre channel I/O adapter is the failing item.
- **FCPORT**  
The Fibre Channel IOA port may be the failing item.
- **FRPORT**  
The RIO controller or adapter on one end of the link may be the failing item.
- **FWADIPL**  
Look here for information about FWADIPL symbolic FRU.
- **FWCD1**  
Look here for information about FWCD1 symbolic FRU.
- **FWCD2**  
Look here for information about FWCD2 symbolic FRU.

- **FWCONS**  
Look here for information about FWCONS symbolic FRU.
- **FWENET**  
Look here for information about FWENET symbolic FRU.
- **FWFLASH**  
Look here for information about FWFLASH symbolic FRU.
- **FWFWPBL**  
Look here for information about FWFWPBL symbolic FRU.
- **FWHANG**  
Symbolic FRU FWHANG is not supported at this time.
- **FWHOST**  
Look here for information about FWHOST symbolic FRU.
- **FWIDE1**  
Look here for information about FWIDE1 symbolic FRU.
- **FWIDE2**  
Look here for information about FWIDE2 symbolic FRU.
- **FWIPIPL**  
Look here for information about FWIPIPL symbolic FRU.
- **FWLPAR**  
Look here for information about FWLPAR symbolic FRU.
- **FWMBOOT**  
This checkpoint appears on the operator panel when partition firmware has entered the boot devices menu in the SMS because the multi-boot flag was turned on.
- **FWNIM**  
If this error occurs during the installation of AIX via a process called a NIM push, the `set_bootlist` attribute may not have been set correctly on the NIM master.
- **FWNVR1**  
An error reported against the NVRAM can be caused by low battery voltage and (more rarely) power outages that occur during normal system usage.
- **FWNVR2**  
Look here for information about FWNVR2 symbolic FRU.
- **FWNVR3**  
Execution of a command line within the `nvrarc` configuration variable `nvrarc(script)` resulted in a "throw" being executed.
- **FWPCI1**  
Look here for information about FWPCI1 symbolic FRU.
- **FWPCI2**  
Look here for information about FWPCI2 symbolic FRU.
- **FWPCI3**  
Look here for information about FWPCI3 symbolic FRU.
- **FWPCI4**  
Look here for information about FWPCI4 symbolic FRU.
- **FWPCI5**  
Look here for information about FWPCI5 symbolic FRU.
- **FWPCI6**  
Look here for information about FWPCI6 symbolic FRU.
- **FWPTR**  
Values normally found in nonvolatile storage that point to the location of an operating system were not found.
- **FWPWD**  
Look here for information about FWPWD symbolic FRU.
- **FWRIPL**  
Look here for information about FWRIPL symbolic FRU.
- **FWSCSI1**  
Look here for information about FWSCSI1 symbolic FRU.
- **FWSCSI2**  
Look here for information about FWSCSI1 symbolic FRU.
- **FWSCSI3**  
Look here for information about FWSCSI1 symbolic FRU.
- **FWSCSI4**  
Look here for information about FWSCSI1 symbolic FRU.
- **FWSCSI5**  
Look here for information about FWSCSI5 symbolic FRU.
- **FWSCSIH**  
Look here for information about FWSCSIH symbolic FRU.
- **FWVTHMC**  
Look here for information about FWVTHMC symbolic FRU.

- **HCA**  
The failing component is the Host Channel Adapter.
- **HMCLIC**  
Firmware on the Hardware Management Console (HMC) must be replaced.
- **HMCMTWK**  
Multiple connections to peer HMCs have been lost.
- **HMCNTWK**  
A connection to a peer HMC (indicated in the location code) has been lost.
- **HMUX**  
Use this procedure to determine the failing error path and associated FRUs for ESCALA PL 1650R-L+ or 5/7x single and multi-drawer systems.
- **HPSA575**  
This procedure refers to a high performance switch (HPS) switch network interface (SNI) in a 5/75 server.
- **HPSA590**  
This procedure refers to a high performance switch (HPS) switch network interface (SNI) in an ESCALA PL 3250R or ESCALA PL 6450R server.
- **HPSASNI**  
This procedure refers to a high performance switch (HPS) switch network interface (SNI).
- **HPSCCAB**  
This procedure refers to a high performance switch (HPS) network cable. HPS network cables are fiber or copper and are available in several lengths.
- **HPSCCOP**  
This procedure refers to a copper cable used in the high performance switch (HPS) network. This type of copper cable is available in several lengths.
- **HPSCFIB**  
This procedure refers to a fiber cable used in the high performance switch (HPS) network.
- **HPSSPCC**  
This procedure refers to a high performance switch (HPS) switch port connection card (SPCC).
- **HPSSSW**  
This procedure refers to a high performance switch (HPS) planar.
- **HSLH**  
This is a hybrid HSL/RIO to HSL2/RIO-G copper cable where one end has an HSL/RIO yellow connector and the other end has an HSL2/RIO-G black connector.
- **HSLH\_xx**  
This is a hybrid HSL/RIO to HSL2/RIO-G copper cable where one end has an HSL/RIO yellow connector and the other end has an HSL2/RIO-G black connector.
- **HSLH\_06**  
This is a hybrid HSL/RIO to HSL2/RIO-G copper cable where one end has an HSL/RIO yellow connector and the other end has an HSL2/RIO-G black connector.
- **HSLH\_15**  
This is a hybrid HSL/RIO to HSL2/RIO-G copper cable where one end has an HSL/RIO yellow connector and the other end has an HSL2/RIO-G black connector.
- **HSL\_I**  
This is an HSL/RIO interposer card for copper HSL2/RIO-G (black) connections or optical HSL/RIO connections.
- **HSL\_Ix**  
This is an HSL/RIO interposer card for copper HSL2/RIO-G (black) connections or optical HSL/RIO connections.
- **HSL\_I2**  
The failing item is an HSL2/RIO-G interposer card on machine type 9406 model 825.
- **HSL\_I3**  
The failing item is an HSL/RIO interposer card on machine type 9406 model 825.
- **HSL\_I4**  
The failing item is an HSL2/RIO-G interposer card on a 406/1D expansion unit.
- **HSL\_LNK**  
When a RIO cable is disconnected, it may result in a lost connection between the units even after the cable is reconnected.
- **HSL\_OPT**  
This is an optical HSL/RIO cable.
- **HSL1**  
This is a standard copper HSL/RIO cable at both ends.
- **HSL1\_UN**  
This is a standard copper HSL/RIO cable at the end where an error was detected.
- **HSL2**  
This is an HSL2/RIO-G copper HSL/RIO cable at both ends.

- **HSL2\_xx**  
This is an HSL2/RIO-G copper HSL/RIO cable at both ends.
- **HSL2\_01**  
This is an HSL2/RIO-G copper HSL/RIO cable at both ends.
- **HSL2\_03**  
This is an HSL2/RIO-G copper HSL/RIO cable at both ends.
- **HSL2\_08**  
This is an HSL2/RIO-G copper HSL/RIO cable at both ends.
- **HSL2\_10**  
This is an HSL2/RIO-G copper HSL/RIO cable at both ends.
- **HSL2\_15**  
This is an HSL2/RIO-G copper HSL/RIO cable at both ends.
- **HSL2\_17**  
This is an HSL2/RIO-G copper HSL/RIO cable at both ends.
- **HSL2\_25**  
This is an HSL2/RIO-G copper HSL/RIO cable at both ends.
- **I2CBUS**  
A fault was detected on the I2C bus.
- **IDPART**  
A system unit part is failing.
- **IOA**  
You need to determine the field replaceable unit (FRU) part number.
- **IOACNFG**  
There is an IOA configuration problem.
- **IOADPTR**  
The hardware, firmware, microcode, or device driver of an adapter or card slot detected an error.
- **IOBRDG**  
The failing component is the RIO I/O bridge on the IPL path.
- **IO\_DEV**  
A storage device is the failing item.
- **IO\_HUB**  
The failing component is the RIO NIC on the IPL Path.
- **IOP**  
Replace the I/O processor.
- **LBSADP1**  
This symbolic FRU is not supported on the system.
- **LBSADP2**  
This symbolic FRU is not supported on the system.
- **LBSADP3**  
This symbolic FRU is not supported on the system.
- **LBSADP4**  
This symbolic FRU is not supported on the system.
- **LBSADP5**  
This symbolic FRU is not supported on the system.
- **LBUSADP**  
This symbolic FRU is not supported on the system.
- **LICCODE**  
This procedure helps determine the preferred method of updating the server's Licensed Internal Code (LIC).
- **LITSTRP**  
Look here for information about LITSTRP symbolic FRU.
- **LOADCY1**  
Cryptographic adapter licensed internal code not loaded.
- **LOC\_SYS**  
A problem has occurred on the local (this) system with HSL OptiConnect.
- **LPARCFG**  
There is a configuration problem with the system or a logical partition.
- **LPARSUP**  
There is either an IPL problem, a main storage dump problem, or a software error with a partition.
- **LSERROR**  
There was an error when the platform LIC attempted to locate the partition's load source.
- **MA\_BRDG**  
The problem is the multi-adapter bridge hardware on a system bus.
- **MABRCFG**  
The multi-adapter bridge hardware detected a configuration problem.
- **MAILBOX**  
Connection monitoring errors have been detected, indicating mailbox failures.

- **MASBUS**  
The multi-adapter bridge detected a problem with a connection to a PCI adapter that it controls either in a physical card location or embedded in a FRU.
- **MEDIA**  
The drive or media may be dirty, or the media may be defective.
- **MEDIABP**  
Use this procedure to determine what Media backplane to replace on ESCALA PL 250T/R, ESCALA PL 450T/R, or an ESCALA PL 850R/PL 1650R/R+
- **MEMBRD**  
The failing component is the board the memory DIMMs plug into.
- **MEMCTLR**  
The failing component is one of the memory controllers.
- **MEMORY**  
Use this topic to view memory and location information for the 2890 and 2892 Integrated xSeries Server (IXS) cards.
- **MEMDIMM**  
The failing component is one of the memory DIMMs.
- **MESSAGE**  
Messages provided with this symbolic FRU's description appear in the Service Action Log (SAL).
- **MOVEIOA**  
An incorrect hardware configuration was detected.
- **MSGxxxx**  
If you were sent here from a symbolic FRU with the format "MSGxxxx," use the following links to go to the message number's symbolic FRU.
- **MSG0001**  
This symbolic FRU represents a specific message to the service provider relative to the reference code or FRU list for cases where it is needed.
- **MSG0002**  
This symbolic FRU represents a specific message to the service provider relative to the reference code or FRU list for cases where it is needed.
- **MSG0003**  
This symbolic FRU represents a specific message to the service provider relative to the reference code or FRU list for cases where it is needed.
- **MSG0005**  
This symbolic FRU represents a specific message to the service provider relative to the reference code or FRU list for cases where it is needed.
- **NETSERV**  
The Integrated xSeries Server (IXS) is the failing item.
- **NEXTLVL**  
Contact your next level of support.
- **NODEPL**  
The failing component is the node backplane.
- **NOFRUS**  
No failing items are identified for the reference code.
- **NO\_PNUM**  
Diagnostic firmware could not determine a part number for the FRU.
- **NSCABLE**  
The cable between the Integrated xSeries Adapter (IXA) card and the RS-485 port on the Integrated xSeries Server (IXS) is the failing item.
- **NTDEVDR**  
The Windows server device driver may be causing the problem.
- **NTLANDD**  
The Windows server virtual LAN device driver may be causing the problem.
- **NTOPSYS**  
The Windows server operating system may be causing the problem.
- **NTUSER**  
Indicates a Windows server user problem.
- **NTVSCSI**  
The Windows server virtual SCSI device driver may be causing the problem.
- **OPT\_CLN**  
Use the fiber optic cleaning kit and the fiber optic cleaning procedures in "SY27-2604 Fiber Optic Cleaning Procedures" for all fiber channel connections such as those used in optical high speed link (HSL) connections or fibre channel attached devices.
- **OPTLCBL**  
The cabling for an optical disk drive in the optical library needs to be checked.
- **OPTLDRV**  
An optical disk drive in the optical library is failing.

- **OPUSER**  
The failing item indicates that the operator of the system console or the control panel performed an incorrect action.
- **OSLIC**  
An operating system has experienced a fatal error.
- **OSTERM**  
The operating system in a partition has terminated abnormally.
- **PGDPART**  
Look here for information about PGDPART symbolic FRU.
- **PIOCARD**  
The multi-adapter bridge hardware that controls PCI adapters and PCI card slots detected an error.
- **PLDUMP**  
A platform dump occurred.
- **PLUS**  
The list of possible failing items that are displayed online is not complete.
- **PPCIMIN**  
The affected component is a primary PCI bus in an I/O unit.
- **PPCISYS**  
The failing component is the primary PCI bus in a system unit.
- **PPCITWR**  
PPCITWR: Primary PCI bus in an I/O unit.
- **PRIMIOA**  
Replace the storage I/O adapter to which the auxiliary cache I/O adapter is connected.
- **PRI\_PCI**  
This is a primary PCI bus generated under a RIO adapter/HSL I/O bridge.
- **PTFSRCH**  
Licensed Internal Code is the failing item. Look for fixes (PTFs) associated with the reference code and have the customer apply them.
- **PTNNTWK**  
One or more connections to a partition have been lost.
- **PWRCBL**  
The failing item is the SPCN frame-to-frame cable or adapter.
- **PWROC**  
The battery charger is reporting a load fault.
- **PWRSPLY**  
A power supply might be the failing item.
- **QDCCRLS**  
Licensed Internal Code is the failing item.
- **QSYSOPR**  
Look here for information about QSYSOPR symbolic FRU.
- **REFER**  
Look here for information about REFER symbolic FRU.
- **REM\_NIC**  
One end of the failed link is a system unit other than the one reporting this error.
- **REM\_SYS**  
A problem has occurred in a remote system that is in an HSL OptiConnect loop.
- **SIADPCD**  
The failing component is the HSL I/O bridge card or RIO adapter card in an I/O unit, or the integrated xSeries adapter card in an xSeries server.
- **SI\_CARD**  
The failing component is the RIO adapter card in the system unit.
- **SICNTRL**  
The failing component is the network interface controller (NIC)/RIO controller.
- **SIIOADP**  
SIIOADP: RIO adapter/HSL I/O bridge (in a system unit or I/O unit).
- **SI\_PHB**  
The HSL I/O bridge/RIO adapter hardware in a system or I/O unit is failing.
- **SIRGCBL**  
This symbolic FRU is not supported on the system.
- **SIRGCFG**  
An invalid configuration was detected on an HSL/RIO loop during IPL.
- **SIRSTAT**  
A status indication for a RIO loop is identified in the reference code.
- **SLOTERR**  
The multi-adapter bridge detected a problem with a card location that it controls.
- **SLOTUSE**  
The card in the given slot is not available for use.

- **SNSDATA**  
Look here for information about SNSDATA symbolic FRU.
- **SPBUS**  
The path to the service processor may be the failing item.
- **SPNETWK**  
A connection between an HMC and either a service processor or BPC has been lost. The location code will identify the unit to which contact was lost.
- **SPNLCRD**  
This symbolic FRU is no longer supported.
- **SRCTB1X**  
There is a failure detected by the power subsystem.
- **STORIOA**  
Replace the storage I/O adapter.
- **SVCDPCS**  
Look here for information about SVCDPCS symbolic FRU.
- **SVCPROC**  
The service processor is failing.
- **SYSBKPL**  
The failing component is the system backplane.
- **SYSBKPL2**  
The failing component is the system backplane.
- **SYSNTWK**  
There has been a network adapter failure on this HMC.
- **TAPCLN**  
Clean the tape unit.
- **TAPCNFG**  
Look here for information about TAPCNFG symbolic FRU.
- **TOD**  
This symbolic FRU is no longer supported.
- **TOD\_BAT**  
The battery for the time-of-day battery is low or failing.
- **TOPORT**  
The RIO adapter or controller on one end of the link may be the failing item.
- **TWRBKPL**  
The failing item is the tower card in an I/O unit.
- **TWRCARD**  
A SPCN card might be failing. The SPCN card can be on either an adapter style card or integrated on the system backplane.
- **TWRPLNR**  
The failing component is in the PCI planar board of an I/O unit.
- **UC235**  
The problem may be that the card (a resource) was removed from the card enclosure without updating the system configuration records.
- **UC236**  
The problem may be that the card (a resource) is not correctly plugged into the card enclosure.
- **UG3AS**  
An error has been detected in the licensed internal code.
- **UJ0E2**  
The problem has been isolated to the remote data terminal equipment.
- **UJ0E3**  
The problem has been isolated to the local modem or the hardware that links to the remote end.
- **UJ0E6**  
The problem has been isolated to the remote modem, or the remote system or controller.
- **UJ0E7**  
The problem has been isolated to the telephone line equipment that links the local and the remote equipment.
- **UJ0E9**  
The problem has been isolated to the X.25 network.
- **UJ6P3**  
An error occurred in the Facsimile Support/400 Licensed Program. Please contact your next level of support for possible corrective actions.
- **UJ9GC**  
The configuration for the wireless network has been identified as a cause of the problem.
- **UJA32, UJC38**  
The communication line or the automatic call unit is already being used.
- **UJA33, UJP37**  
The problem can be caused by too many active lines using the same input/output processor (IOP)



card or by setting the line speed too high.

- **UJA34**  
A configuration parameter may be incorrect.
- **UJA35**  
A configuration parameter may be incorrect.
- **UJA36**  
A configuration parameter may be incorrect.
- **UJB35**  
A configuration parameter may be incorrect.
- **UJB36**  
A configuration parameter may be incorrect.
- **UJC35**  
A configuration parameter may be incorrect.
- **UJC36**  
A configuration parameter may be incorrect.
- **UJE31**  
There could be a problem with the Token-Ring Network Manager program.
- **UJE32**  
There could be a problem with the Token-Ring Network Management function.
- **UJE33**  
The token-ring adapter returned status information because it has received a beacon frame from the token-ring network.
- **UJE34**  
The error message may have been logged from a temporary error that is not caused by equipment failure.
- **UJE35**  
A configuration parameter may be incorrect.
- **UJE36**  
A configuration parameter may be incorrect.
- **UJE37**  
The problem may be at the remote site.
- **UJE38**  
Too many jobs are running that use the communications controller.
- **UJE39**  
The problem may be at the remote site.
- **UJE40**  
The problem may be at the remote site or on the network media.
- **UJJ35**  
A configuration parameter may be incorrect.
- **UJJ36**  
A configuration parameter may be incorrect.
- **UJJ37**  
The error message may have been logged from a temporary error that is not caused by equipment failure.
- **UJJ38**  
A user specified X.25 facility, such as packet size, window size, reverse charging, or closed user group, may not have been correctly assigned.
- **UJJ39**  
Look here for information about UJJ39 symbolic FRU.
- **ULNZ3**  
The problem may be a communications line problem.
- **ULNZ4**  
Independent workstation and SDLC support.
- **UNM31**  
A configuration parameter may be incorrect.
- **UNM32**  
The licensed internal code of the communications I/O card cannot obtain a necessary resource because of a heavy workload.
- **UNM35**  
There could be a problem at the remote U interface, between the NT1 node and the Integrated Services Digital Network (ISDN).
- **UNM36**  
There may be a problem in the Integrated Services Digital Network (ISDN).
- **UNM38**  
The required program temporary fix (PTF) is not installed.
- **UNP20**  
The internal code of the I/O card that detected the error may be defective.

- **UNU01**  
Electrical noise in the local environment can cause performance degradation or loss of an ISDN communications link.
- **UNU02**  
The problem may be at the remote location.
- **UNU31**  
A configuration parameter may be incorrect.
- **UNU32**  
A configuration parameter may be incorrect.
- **UPLF1**  
The system may not have been able to complete the APPN session initiation due to the number of jobs that were active when the timeout occurred.
- **UPSUNIT**  
The uninterruptible power supply (UPS) may be the failing component.
- **USER**  
There has been a system operator error or user error. See the system operator information.
- **UX201**  
The printer definition table may be causing the problem. See the original system message for cause and recovery information about the error.
- **UX202**  
A problem was detected while downloading a device licensed internal code change to the device.
- **UY1Z1**  
Indicates possible cable problems
- **UY1Z2**  
This error occurs if you attempted to activate more workstations than the amount allowed.
- **UY1Z3**  
This error is caused by a workstation that is connected to the port.
- **UY1Z4**  
An error occurred with the pass-through command between the workstation controller and the workstation.
- **UY1Z5**  
The communication between the workstation controller and a workstation was interrupted during an active session.
- **VPDPART**  
Look here for information about VPDPART symbolic FRU.
- **VRMOD**  
The system detected a voltage problem.

Parent topic: [Isolating problems](#)

---

## ACMODUL

Your server has suffered a power loss. This procedure will help you determine the source of the power loss condition that brought you here.

If the system or tower that exhibited the power loss powers on normally, or stays powered on after an ac power failure, replacement of parts might not be needed. Power failures can be caused by brown outs, building or room power receptacle power loss, loose or disconnected power cords, or possible hardware conditions.

1. Are you working with a model ESCALA PL 3250R, PL 3250R+, ESCALA PL 6450 or PL 6450R+?
  - ◆ **No:** Continue with the next step.
  - ◆ **Yes:** Choose one of the following:
    - ◇ If you are here because of a 19" SPCN controlled expansion tower or drawer problem, continue with the next step.
    - ◇ If you are here because of a problem related to a 24" system unit, go to [PWR1912](#).
2. Is the failing unit configured with a redundant power supply option (or dual line cord feature)?
  - ◆ **No:** Continue with the next step.
  - ◆ **Yes:** Go to [PWR1911](#).
3. Are all the units powered on?

- ◆ **Yes:** This error may have been caused by an ac outage. If the system will power on without an error, no parts need to be replaced. **This ends the procedure.**
- ◆ **No:** On the unit that does not power on, perform the following :
  - a. Disconnect the ac line cord from the unit that does not power on.
  - b. Use a multimeter to measure the ac voltage at the system end of the ac line cord.
  - c. Is the ac voltage correct? (Refer to [Table 1](#).)
    - **Yes:** Continue with the next step.
    - **No:** Go to step 7.

Table 1. Correct AC voltage

| Model or expansion unit                                                                                                                                                                                                                                                 | Correct AC voltage           |
|-------------------------------------------------------------------------------------------------------------------------------------------------------------------------------------------------------------------------------------------------------------------------|------------------------------|
| Models 112/85, ESCALA PL 250R-VL or ESCALA PL 450R-XS, ESCALA PL 250R-L, PL 250R-L+ or PL 450R-VL+, ESCALA PL 250T/R, PL 250T/R+ or PL 450T/R-L+, ESCALA PL 450T/R, PL 450T/R+ or PL 850T/R-L+, ESCALA PL 850R/PL 1650R/R+, or 50/95, 05/95, and 11D/20 expansion units | 100V to 127V or 200V to 240V |
| 50/74, 50/79, 50/88, 05/88, 50/94, 52/94, 57/90, 11D/10, and 11D/11 expansion units                                                                                                                                                                                     | 200V to 240V                 |

4. Are you working on model 112/85, ESCALA PL 250R-VL or ESCALA PL 450R-XS, ESCALA PL 250R-L, PL 250R-L+ or PL 450R-VL+, ESCALA PL 250T/R, PL 250T/R+ or PL 450T/R-L+, ESCALA PL 450T/R, PL 450T/R+ or PL 850T/R-L+, ESCALA PL 850R/PL 1650R/R+, 50/88, 05/88, 50/95, 05/95, 57/90, 11D/10, 11D/11 and 11D/20 expansion unit?
- ◆ **No:** Continue with the next step.
  - ◆ **Yes:** Perform the following:
    - a. Reconnect the ac line cord.
    - b. Verify that the failing system or tower fails to power on.
    - c. Replace the failing power supply (refer to [Table 2](#)).

Table 2. List of failing parts

| Model or expansion unit                                 | Failing part(s)                                                           | Link to locations                                                                                                                                                      |
|---------------------------------------------------------|---------------------------------------------------------------------------|------------------------------------------------------------------------------------------------------------------------------------------------------------------------|
| ESCALA PL 250T/R, PL 250T/R+ or PL 450T/R-L+            | Power supply E1                                                           | <a href="#">Locations</a> <a href="#">model</a><br>ESCALA PL 250T/R,<br>ESCALA PL 250T/R+ or<br>ESCALA PL 450T/R-L+,<br>and 112/85                                     |
| ESCALA PL 250R-VL or<br>ESCALA PL 450R-XS               | Power supply E1                                                           | <a href="#">Locations</a> <a href="#">Model</a><br>ESCALA PL 250R-VL or<br>ESCALA PL 450R-XS                                                                           |
| ESCALA PL 250R-L, PL<br>250R-L+ or PL 450R-VL+          | Power supply E1                                                           | <a href="#">Locations</a> <a href="#">model</a><br>ESCALA PL 250R-L                                                                                                    |
| ESCALA PL 450T/R, PL<br>450T/R+ or PL 850T/R-L+         | Power supply E1                                                           | <a href="#">Locations</a> <a href="#">model</a><br>ESCALA PL 450T/R,<br>ESCALA PL 450T/R+ or<br>ESCALA PL 850T/R-L+,                                                   |
| ESCALA PL 1650R-L+<br>and ESCALA PL 850R/PL<br>1650R/R+ | Power supply E1                                                           | <a href="#">Locations</a> <a href="#">model</a><br>ESCALA PL 1650R-L+<br>and ESCALA PL 850R/PL<br>1650R/R+                                                             |
| 50/74 and 50/79 (single<br>line cord)                   | Power supply P01<br>Power supply P02<br>Power supply P03<br>AC module A01 | <a href="#">Locations</a> <a href="#">50/74</a> ,<br>8079-002, and 8093-002<br>expansion units or<br><a href="#">Locations</a> <a href="#">50/79</a><br>expansion unit |
| 50/88 and 05/88                                         | Power supply P01                                                          | <a href="#">Locations</a> <a href="#">05/88</a> and<br>50/88 expansion units                                                                                           |

Service provider information

|                                  |                                                                                            |                                                                                                     |
|----------------------------------|--------------------------------------------------------------------------------------------|-----------------------------------------------------------------------------------------------------|
| 50/94                            | Power supply P01<br>Power supply P02<br>Power supply P03<br>AC module A01<br>AC module A02 | Locations 50/94, 52/94,<br>and 8094-002 expansion<br>units                                          |
| 50/95 and 05/95                  | Power supply P01                                                                           | Locations 05/95 and<br>50/95 expansion units                                                        |
| 11D/10, 11D/11, 11D/20,<br>57/90 | Power supply E1                                                                            | Locations 11D/10 and<br>11D/11 and 57/90<br>expansion unit or<br>Locations 11D/20<br>expansion unit |

5. Perform the following:
  - a. Reconnect the ac line cord to the ac module.
  - b. Remove the ac jumper cables at the power supplies.
  - c. Use a multimeter to measure the ac voltage at the jumper cable power supply end.

Is the ac voltage from 200V to 240V?

  - ◆ **No:** Continue with the next step.
  - ◆ **Yes:** Replace the failing power supply (refer to [Table 2](#)). **This ends the procedure.**
6. Perform the following:
  - a. Disconnect the ac jumper cable at the ac module output.
  - b. Use a multimeter to measure the ac voltage at the ac module output.

Is the ac voltage from 200V to 240V?

  - ◆ **No:** Exchange the ac module (refer to [Table 2](#)). **This ends the procedure.**
  - ◆ **Yes:** Replace the ac jumper cable (refer to [Power and signal cables](#)). **This ends the procedure.**
7. Perform the following:
  - a. Disconnect the line cord from the customer's ac power outlet.
  - b. Use a multimeter to measure the ac voltage at the customer's ac power outlet.

Is the ac voltage correct? (Refer to [Table 1](#).)

  - ◆ **Yes:** Exchange the failing ac line cord. **This ends the procedure.**
  - ◆ **No:** Perform the following:
    - a. Inform the customer that the ac voltage at the power outlet is not correct.
    - b. After the ac voltage at the power outlet is correct, reconnect the ac line cord to the power outlet. **This ends the procedure.**

Parent topic: [Symbolic FRUs](#)

---

## Power and signal cables

The following diagrams illustrate the logical cable connections in the system unit, and in the expansion unit.

Select the unit that you are working on.

- **Model ESCALA PL 245T/R cables**  
Signal and power cables.
- **Model ESCALA PL 250R-VL or ESCALA PL 450R-XS cables**  
Power cables.
- **Model ESCALA PL 250R-L, PL 250R-L+ or PL 450R-VL+ cables**  
Power cables.
- **Model ESCALA PL 250T/R, PL 250T/R+ or PL 450T/R-L+ cables**  
Power cables.
- **Model ESCALA PL 450T/R, PL 450T/R+ or PL 850T/R-L+ cables**  
Power cables.
- **Model ESCALA PL 1650R-L+ and ESCALA PL 850R/PL 1650R/R+ cables**  
Power cables.
- **Model 5/75 cables**  
Power cables.
- **Model ESCALA PL 3250R, PL 3250R+, ESCALA PL 6450 or PL 6450R+ cables**  
Power cables.
- **50/74, 50/79, 50/94, 52/94, 8079-002, 8093-002, 8094-002, and 82/94 expansion unit cables**  
Expansion unit cables.

- **50/88 and 05/88 expansion unit cables**  
Expansion units power and signal cables.
- **50/95 and 05/95 expansion unit cables**  
Power expansion unit cables.
- **57/95 expansion unit cables**  
Expansion unit cables.
- **11D/20 expansion unit cables**  
Expansion unit power cables.

Parent topic: [Cables](#)

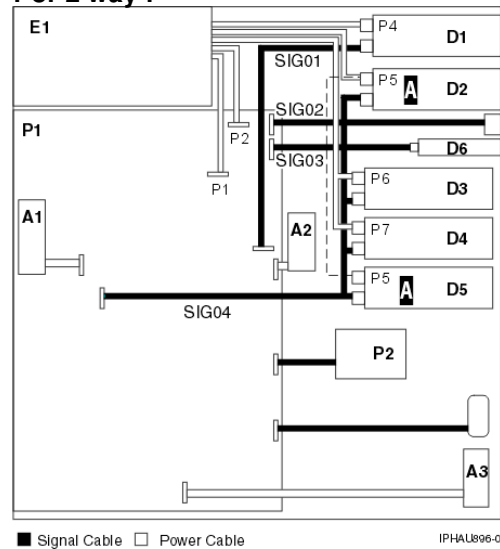
## Model ESCALA PL 245T/R cables

Signal and power cables.

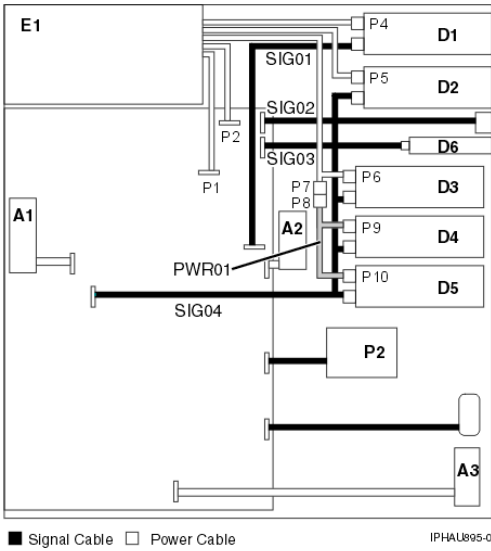
Table 1. Part numbers for the signal cables and the one power jumper (for the 1 way ESCALA PL 245T/R)

| Name  | Description | Part number |
|-------|-------------|-------------|
| SIG01 | IDE cable   | 39J4137     |
| SIG02 | USB cable   | 42R4100     |
| SIG03 | Op panel    | 39J4135     |
| SIG04 | SCSI cable  | 42R4142     |
| PWR01 | Jumper      | 42R4439     |

### 1 or 2 way f



### 1 way for ESCALA PL 245T/R



**2 way for ESCALA PL 245T/R**

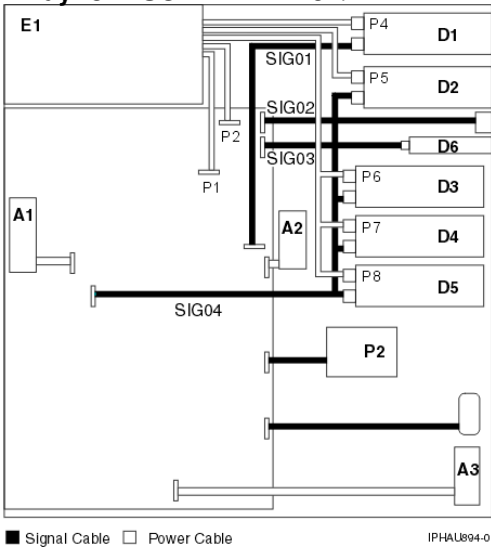


Table 2. Model ESCALA PL 245T/R cables

| Name | Description                                 | Part number |
|------|---------------------------------------------|-------------|
|      | 14' power cord, 200-240 V, 10 A             | 39M5378     |
|      | 9' power cord 250 V 10 A                    | 39M5151     |
|      | 9' power cord, 250 V, 10 A                  | 39M5219     |
|      | 9' power cord, 200-240 V, 15 A              | 39M5254     |
|      | 9' power cord, 250 V, 10 A                  | 39M5226     |
|      | 9' power cord, 250 V, 10 A                  | 39M5165     |
|      | 9' power cord, 100-127 V, 15 A              | 39M5247     |
|      | 9' power cord, 250 V, 10 A                  | 39K4947     |
|      | 14' power cord, 200-240 V, 15 A, IEC320/C13 | 39M5096     |
|      | 14' power cord, 200-240 V, 15 A, IEC320/C13 | 39M5187     |
|      | 14' power cord, 127 V, 15 A                 | 39M5200     |

|  |                                         |         |
|--|-----------------------------------------|---------|
|  | 9' power cord, 250 V, 10 A, IEC320/C13  | 39M5158 |
|  | 9' power cable. 250 V, 10 A, IEC320/C13 | 39M5130 |

Parent topic: [Power and signal cables](#)

---

## Model ESCALA PL 250R-VL or ESCALA PL 450R-XS cables

Power cables.

Table 1. Model - cables

| Name | Description                                 | Part number |
|------|---------------------------------------------|-------------|
|      | 9' power cord, 250 V 10 A                   | 39M5151     |
|      | 9' power cord, 250 V, 10 A                  | 39M5219     |
|      | 9' power cord, 200-240 V, 15 A              | 39M5254     |
|      | 9' power cord, 250 V, 10 A                  | 39M5226     |
|      | 9' power cord, 250 V, 10 A                  | 39M5165     |
|      | 9' power cord, 100-127 V, 15 A              | 39M5247     |
|      | 9' power cord, 250 V, 10 A                  | 39K4947     |
|      | 14' power cord, 200-240 V, 15 A, IEC320/C13 | 39M5096     |
|      | 14' power cord, 200-240 V, 15 A, IEC320/C13 | 39M5187     |
|      | 14' power cord, 127 V, 15 A                 | 39M5200     |
|      | 9' power cord, 250 V, 10 A, IEC320/C13      | 39M5158     |
|      | 9' power cable. 250 V, 10 A, IEC320/C13     | 39M5130     |

Parent topic: [Power and signal cables](#)

---

## Model ESCALA PL 250R-L, PL 250R-L+ or PL 450R-VL+ cables

Power cables.

Table 1. Model ESCALA PL 250R-L, ESCALA PL 250R-L+ or ESCALA PL 450R-VL+, - cables

| Name | Description                                 | Part number |
|------|---------------------------------------------|-------------|
|      | 9' power cord 250 V 10 A                    | 39M5151     |
|      | 9' power cord, 250 V, 10 A                  | 39M5219     |
|      | 9' power cord, 200-240 V, 15 A              | 39M5254     |
|      | 9' power cord, 250 V, 10 A                  | 39M5226     |
|      | 9' power cord, 250 V, 10 A                  | 39M5165     |
|      | 9' power cord, 100-127 V, 15 A              | 39M5247     |
|      | 9' power cord, 250 V, 10 A                  | 39K4947     |
|      | 14' power cord, 200-240 V, 15 A, IEC320/C13 | 39M5096     |
|      | 14' power cord, 200-240 V, 15 A, IEC320/C13 | 39M5187     |
|      | 14' power cord, 127 V, 15 A                 | 39M5200     |
|      | 9' power cord, 250 V, 10 A, IEC320/C13      | 39M5158     |
|      | 9' power cable. 250 V, 10 A, IEC320/C13     | 39M5130     |

Parent topic: [Power and signal cables](#)

## Model ESCALA PL 250T/R, PL 250T/R+ or PL 450T/R-L+ and 112/85 cables

Power cables.

Table 1. Model 112/85, ESCALA PL 250T/R+ or ESCALA PL 450T/R-L+, 9405-520, 9406-520, and ESCALA PL 250T/R - cables

| Name | Description                                              | Part number |
|------|----------------------------------------------------------|-------------|
|      | 9' power cord 250 V 10 A                                 | 39M5151     |
|      | 9' power cord, 250 V, 10 A                               | 39M5219     |
|      | 14' power cord, 200-240 V, 10 A                          | 36L8877     |
|      | 9' power cord, 200-240 V, 15 A                           | 39M5254     |
|      | 9' power cord, 250 V, 10 A                               | 39M5226     |
|      | 9' power cord, 250 V, 10 A                               | 39M5165     |
|      | 9' power cord, 100-127 V, 15 A                           | 39M5247     |
|      | 14' power cord, right angle, 200-240 V, 10 A             | 13F9995     |
|      | 9' power cord, 250 V, 10 A                               | 39K4947     |
|      | 14' power cord, right angle, 200-240 V, 10 A             | 14F0013     |
|      | 4.3 meter power cord, 200 V, 10 A, Denmark               | 13F9998     |
|      | 14' power cord, right angle, 200-240 V 10 A              | 13F9977     |
|      | 14' power cord, 200-240 V, 15 A, IEC320/C19              | 39M5367     |
|      | 14' power cord, 200-240 V, 15 A, IEC320/C13              | 39M5096     |
|      | 14' power cord, 200-240 V, 15 A, IEC320/C13              | 39M5187     |
|      | 14' power cord, right angle, 200-240 V, 10 A, IEC320/C13 | 6952287     |
|      | 14' power cord, right angle, 200-240 V, 10 A, IEC320/C13 | 14F0031     |
|      | 14' power cord, right angle, 200-240 V, 10 A, IEC320/C13 | 14F0049     |
|      | 14' power cord, right angle, 200-240 V, 10 A, IEC320/C13 | 02K0544     |
|      | 14' power cord, 127 V, 15 A                              | 39M5200     |
|      | 14' power cord, 200-240 V, 10 A                          | 39M5331     |
|      | 14' power cord, 200-240 V, 12 A                          | 39M5335     |
|      | 9' power cord, 250 V, 10 A, IEC320/C13                   | 39M5158     |
|      | 14' power cord, 200-240 V, 15 A, IEC320/C19              | 39M5359     |
|      | 14' power cord, 250 V, 10 A                              | 24P6877     |
|      | 14' power cord, right angle, 200-240 V, 10 A, IEC320/C13 | 74P4422     |

Parent topic: [Power and signal cables](#)

## Model ESCALA PL 450T/R, PL 450T/R+ or PL 850T/R-L+ cables

Power cables.



Table 1. Model ESCALA PL 450T/R+ or ESCALA PL 850T/R-L+, 9406-550, ESCALA PL 450T/R, - cables

| Name | Description                                               | Part number |
|------|-----------------------------------------------------------|-------------|
|      | 9' power cord 250 V 10 A                                  | 39M5151     |
|      | 9' power cord, 250 V, 10 A                                | 39M5219     |
|      | 14' power cord, 200-240 V, 10 A                           | 36L8877     |
|      | 9' power cord, 200-240 V, 15 A                            | 39M5254     |
|      | 9' power cord, 250 V, 10 A                                | 39M5226     |
|      | 9' power cord, 250 V, 10 A                                | 39M5165     |
|      | 9' power cord, 100-127 V, 15 A                            | 39M5247     |
|      | 14' power cord, right angle, 200-240 V, 10 A              | 13F9995     |
|      | 9' power cord, 250 V, 10 A                                | 39K4947     |
|      | 14' power cord, right angle, 200-240 V, 10 A              | 14F0013     |
|      | 4.3 meter power cord, 200 V, 10 A, Denmark                | 13F9998     |
|      | 14' power cord, right angle, 200-240 V 10 A               | 13F9977     |
|      | 14' power cord, 200-240 V, 15 A, IEC320/C19               | 39M5367     |
|      | 14' power cord, 200-240 V, 15 A, IEC320/C13               | 39M5096     |
|      | 14' power cord, 200-240 V, 15 A, IEC320/C13               | 39M5187     |
|      | 14' power cord, right angle, 200-240 V, 10 A, IEC320/C13, | 6952287     |
|      | 14' power cord, right angle, 200-240 V, 10 A, IEC320/C13  | 14F0031     |
|      | 14' power cord, right angle, 200-240 V, 10 A, IEC320/C13  | 14F0049     |
|      | 14' power cord, right angle, 200-240 V, 10 A, IEC320/C13  | 02K0544     |
|      | 14' power cord, 127 V, 15 A                               | 39M5200     |
|      | 14' power cord, 200-240 V, 10 A                           | 39M5331     |
|      | 14' power cord, 200-240 V, 12 A                           | 39M5335     |
|      | 9' power cord, 250 V, 10 A, IEC320/C13                    | 39M5158     |
|      | 9' power cable. 250 V, 10 A, IEC320/C13                   | 39M5130     |
|      | 14' power cord, 200-240 V, 15 A, IEC320/C19               | 39M5359     |
|      | 14' power cord, 250 V, 10 A                               | 24P6877     |
|      | 14' power cord, right angle, 200-240 V, 10 A, IEC320/C13  | 74P4422     |

Parent topic: [Power and signal cables](#)

## 50/74, 50/79, 50/94, 52/94, 8079-002, 8093-002, 8094-002, and 82/94 expansion unit cables

Expansion unit cables.

**Note:** The 50/79 expansion unit is serviced as two 50/74 units in the same frame. Cable names and part numbers are repeated in the upper and lower section of the 50/79 frame.

Refer to the following two figures and tables, one for single power cord configurations and one for dual power cord configurations.

Figure 1. Single power cord 50/74, 50/79, 50/94, 52/94, 8079-002, 8093-002, 8094-002, and 82/94 expansion unit - power and signal cables

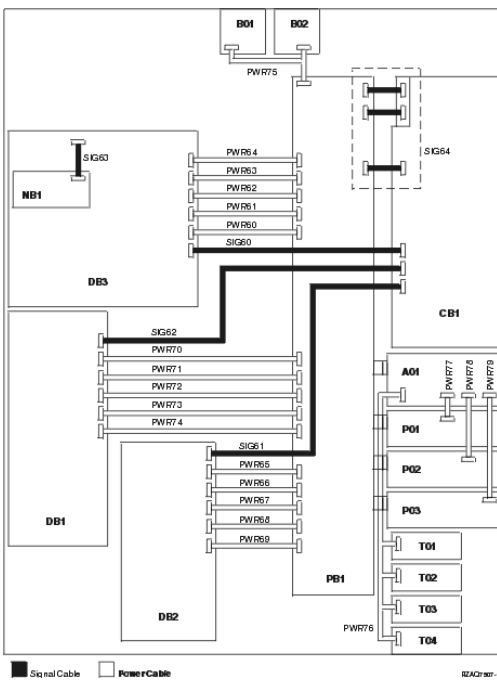


Table 1. Single power cord 50/74, 50/79, 50/94, 52/94, 8079-002, 8093-002, 8094-002, and 82/94 expansion unit - power cables

| Name           | Description                                            | Part number |
|----------------|--------------------------------------------------------|-------------|
| PWR60          | Power distribution board (PB1) to Device board 3 (DB3) | 42R4033     |
| PWR61 to PWR64 | Power distribution board (PB1) to Device board 3 (DB3) | 42R4036     |
| PWR65          | Power distribution board (PB1) to Device board 2 (DB2) | 42R4047     |
| PWR66 to PWR69 | Power distribution board (PB1) to Device board 2 (DB2) | 42R4048     |
| PWR70          | Power distribution board (PB1) to Device board 1 (DB1) | 42R4047     |
| PWR71 to PWR74 | Power distribution board (PB1) to Device board 1 (DB1) | 42R4048     |
| PWR75          | Power distribution board (PB1) to AMDs (B01 and B02)   | 42R4035     |
| PWR76          | Charger (A01) to Batteries (T01 through T04)           | 42R4116     |
| PWR77          | Charger (A01) to Power supply 1 (P01)                  | 04N2181     |

|       |                                 |         |
|-------|---------------------------------|---------|
| PWR78 | Charger to Power supply 2 (P02) | 04N2181 |
| PWR79 | Charger to Power supply 3 (P03) | 04N2181 |

Table 2. Single power cord 50/74, 50/79, 50/94, 52/94, 8079-002, 8093-002, 8094-002, and 82/94 expansion unit - signal cables

| Name  | Description                                                                                                                                                  | Part number |
|-------|--------------------------------------------------------------------------------------------------------------------------------------------------------------|-------------|
| SIG60 | IOA in expansion unit card (CB1) to Device board 3 (DB3)                                                                                                     | 42R4034     |
| SIG61 | IOA in expansion unit card (CB1) to Device board 2 (DB2)                                                                                                     | 44L0070     |
| SIG62 | IOA in expansion unit card (CB1) to Device board 1 (DB1)                                                                                                     | 42R4049     |
| SIG63 | Control panel (NB1) to Device board 3 (DB3)                                                                                                                  | 24L1752     |
| SIG64 | Expansion unit card (CB1) to Power distribution board (PB1 - includes part numbers 97H7476, 97H7477, 97H7607) (Part of the expansion unit card FRU assembly) | 24L0843     |

Figure 2. Dual power cord 50/74, 50/79, 50/94, 52/94, 8079-002, 8093-002, 8094-002, and 82/94 expansion unit - power and signal cables

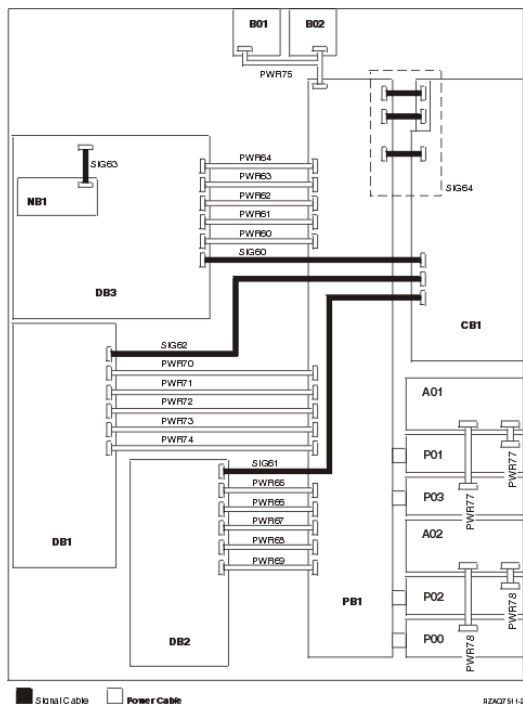


Table 3. Dual power cord 50/74, 50/79, 50/94, 52/94, 8079-002, 8093-002, 8094-002, and 82/94 expansion unit - power cables

| Name           | Description                                            | Part number |
|----------------|--------------------------------------------------------|-------------|
| PWR60          | Power distribution board (PB1) to Device board 3 (DB3) | 42R4033     |
| PWR61 to PWR64 | Power distribution board (PB1) to Device board 3 (DB3) | 42R4036     |
| PWR65          | Power distribution board (PB1) to Device board 2 (DB2) | 42R4047     |
| PWR66 to PWR69 | Power distribution board (PB1) to Device board 2 (DB2) | 42R4048     |
| PWR70          | Power distribution board (PB1) to Device board 1 (DB1) | 42R4047     |
| PWR71 to PWR74 | Power distribution board (PB1) to Device board 1 (DB1) | 42R4048     |
| PWR75          | Power distribution board (PB1) to AMDs (B01 and B02)   | 42R4035     |
| PWR77          | AC input (A01) to Power supply 1 (P01 and P03)         | 04N2181     |
| PWR78          | AC input (A02) to Power supply 2 (P00 and P02)         | 04N2181     |

Table 4. Dual power cord 50/74, 50/79, 50/94, 52/94, 8079-002, 8093-002, 8094-002, and 82/94 expansion unit - signal cables

| Name  | Description                                                                                                                                              | Part number |
|-------|----------------------------------------------------------------------------------------------------------------------------------------------------------|-------------|
| SIG60 | IOA in expansion unit card (CB1) to Device board 3 (DB3)                                                                                                 | 42R4034     |
| SIG61 | IOA in expansion unit card (CB1) to Device board 2 (DB2)                                                                                                 | 44L0070     |
| SIG62 | IOA in expansion unit card (CB1) to Device board 1 (DB1)                                                                                                 | 42R4049     |
| SIG63 | Control panel (NB1) to Device board 3 (DB3)                                                                                                              | 24L1752     |
| SIG64 | Expansion unit card (CB1) to Power distribution board (PB1 - includes part numbers 97H7476, 97H7477, 97H7607) (Part of expansion unit card FRU assembly) | 24L0843     |

Parent topic: [Power and signal cables](#)

---

## 50/88 and 05/88 expansion unit cables

Expansion units power and signal cables.

*Figure 1. 50/88 and 05/88 expansion units - power and signal cables*

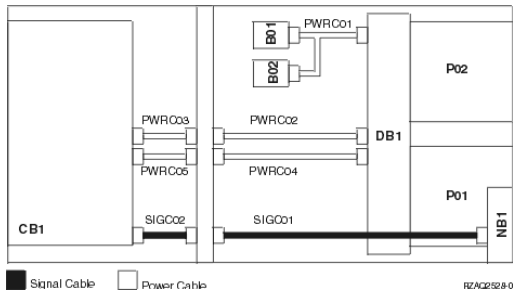


Table 1. 50/88 and 05/88 expansion units - power cables

| Name   | Description                                              | Part number |
|--------|----------------------------------------------------------|-------------|
| PWRC01 | Power Distribution Backplane (PB1) to AMDs (B01 and B02) | 41L5652     |
| PWRC02 | Power Distribution Backplane (PB1) to SPCN connector     | 41L5650     |
| PWRC03 | SPCN connector to expansion unit card (CB1)              | 21P6096     |
| PWRC04 | Power Distribution Backplane (PB1) to Power connector    | 21P6094     |
| PWRC05 | Power connector to expansion unit card (CB1)             | 21P6095     |

Table 2. 50/88 and 05/88 expansion units - signal cables

| Name   | Description                                      | Part number |
|--------|--------------------------------------------------|-------------|
| SIGC01 | Control panel (NB1) to Control panel connector   | 41L5649     |
| SIGC02 | Control panel (NB1) to expansion unit card (CB1) | 41L5517     |

Parent topic: [Power and signal cables](#)

## 50/95 and 05/95 expansion unit cables

Power expansion unit cables.

Use the following diagram and table for information about the power and signal cables for 50/95 and 05/95 expansion units.

Figure 1. 50/95 and 05/95 expansion units - power and signal cables

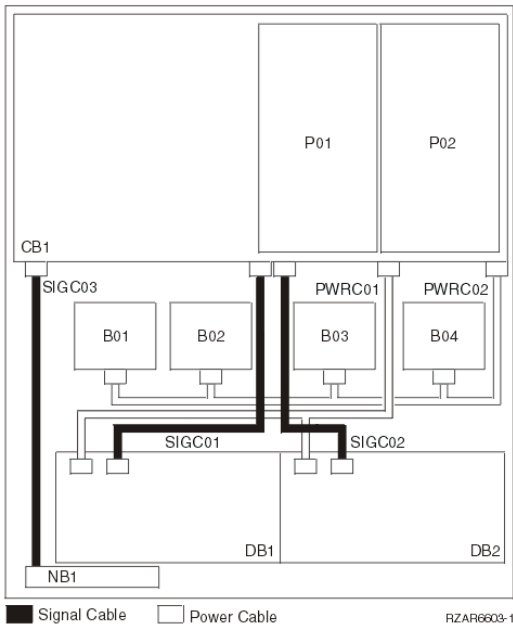


Table 1. 50/95 and 05/95 expansion units - power cables

| Name   | Description                                             | Part number |
|--------|---------------------------------------------------------|-------------|
| PWRC01 | CB1 to device backplanes DB1 and DB2                    | 52P0416     |
| PWRC02 | CB1 to Air moving devices (AMDs) B01, B02, B03, and B04 | 53P4065     |

Table 2. 50/95 and 05/95 expansion units - signal cables

| Name   | Description                                          | Part number |
|--------|------------------------------------------------------|-------------|
| SIGC01 | CB1 to Device backplane (DB1, left/top)              | 53P0417     |
| SIGC02 | CB1 to Device backplane (DB2, right/bottom)          | 53P0418     |
| SIGC03 | Operation panel (NB1) to System unit backplane (CB1) | 53P0414     |

Parent topic: [Power and signal cables](#)

## 57/95 expansion unit cables

Expansion unit cables.

Table 1. 57/95 expansion unit cables

| Name | Description          | Part number |
|------|----------------------|-------------|
|      | SCSI signal cable    | 11P4215     |
|      | SCSI power cable     | 11P4214     |
|      | Operator panel cable | 44P1799     |
|      | Diskette cable       | 44P1800     |

Parent topic: [Power and signal cables](#)

---

## 11D/20 expansion unit cables

Expansion unit power cables.

Table 1. 11D/20 expansion unit power cables

| Name | Description     | Part number |
|------|-----------------|-------------|
|      | Disk unit cable | 53P0416     |
|      | Fan cable       | 53P0419     |

Table 2. 11D/20 expansion unit - signal cables

| Name | Description         | Part number |
|------|---------------------|-------------|
|      | SCSI cable          | 53P0417     |
|      | SCSI cable          | 53P0418     |
|      | Control panel cable | 53P0414     |

Parent topic: [Power and signal cables](#)

---

## AIRMOVR

A fan may be failing. Before replacing any field replaceable units (FRUs), verify that all cables are seated correctly.

Use the following tables to determine the failing fan. Then, see [Finding part locations](#) for the model you are working on to determine the location of the failing item, information on the part number, and a link to the removal and replacement procedure.

Table 1. For Models 112/85, ESCALA PL 250T/R, PL 250T/R+ or PL 450T/R-L+

| Unit reference code | FRU |
|---------------------|-----|
| 7610, 7611          | A1  |
| 7620, 7621          | A2  |
| 7630, 7631          | A3  |

Table 2. For Model ESCALA PL 250R-VL or ESCALA PL 450R-XS

| Unit reference code | FRU |
|---------------------|-----|
| 7610, 7611          | A1  |
| 7620, 7621          | A2  |
| 7630, 7631          | A3  |
| 7640, 7641          | A4  |

Table 3. For Models ESCALA PL 450T/R, PL 450T/R+ or PL 850T/R-L+, 7/20

| Unit reference code | FRU |
|---------------------|-----|
| 7610, 7611          | A3  |
| 7620, 7621          | A4  |
| 7630, 7631          | A2  |
| 7640, 7641          | A1  |

Table 4. For Models ESCALA PL 250R-L, PL 250R-L+ or PL 450R-VL+, ESCALA PL 1650R-L+, ESCALA PL 850R/PL 1650R/R+, 7/10

| Unit reference code | FRU |
|---------------------|-----|
| 7610, 7611          | A1  |
| 7620, 7621          | A2  |

Table 5. For 50/74, 50/79, 50/94, 52/94 expansion units

| Unit reference code | FRU |
|---------------------|-----|
| 7610, 7611          | B01 |
| 7620, 7621          | B02 |

Table 6. For 50/88, 05/88 expansion units

| Unit reference code    | FRU                               |
|------------------------|-----------------------------------|
| 7610, 7611, 7620, 7621 | B02 Cable fan controller card BB1 |
| 7630, 7631, 7640, 7641 | B01 Cable fan controller card BB1 |

Table 7. For 50/95 expansion unit

| Unit reference code | FRU |
|---------------------|-----|
| 7610, 7611          | B01 |
| 7620, 7621          | B02 |
| 7630, 7631          | B03 |
| 7640, 7641          | B04 |

Table 8. For 11D/10, 11D/11, 57/90 expansion units

| Unit reference code | FRU |
|---------------------|-----|
| 7650, 7651          | A5  |



Table 9. For 11D/20 expansion unit

| Unit reference code | FRU |
|---------------------|-----|
| 7610, 7611          | A1  |
| 7620, 7621          | A2  |
| 7630, 7631          | A3  |
| 7640, 7641          | A4  |

**This ends the procedure.**

Parent topic: [Symbolic FRUs](#)

---

## AJDGP01

Licensed Internal Code is the failing item. Look for PTFs associated with the reference code and have the customer apply them.

Parent topic: [Symbolic FRUs](#)

---

## AJDG301

Licensed Internal Code is the failing item. Look for PTFs associated with the reference code and have the customer apply them.

Parent topic: [Symbolic FRUs](#)

---

## AJEDA00

Licensed Internal Code is the failing item. Look for PTFs associated with the reference code and have the customer apply them.

Parent topic: [Symbolic FRUs](#)

---

## AJEGP01

Licensed Internal Code is the failing item. Look for PTFs associated with the reference code and have the customer apply them.

Parent topic: [Symbolic FRUs](#)

---

## AJEQU00

Licensed Internal Code is the failing item. Look for PTFs associated with the reference code and have the customer apply them.

Parent topic: [Symbolic FRUs](#)

---

## AJGAM01

Licensed Internal Code is the failing item. Look for PTFs associated with the reference code and have the customer apply them.

Parent topic: [Symbolic FRUs](#)

---

## AJGDF01

Licensed Internal Code is the failing item. Look for PTFs associated with the reference code and have the customer apply them.

Parent topic: [Symbolic FRUs](#)

---

## AJGFN00

Licensed Internal Code is the failing item. Look for PTFs associated with the reference code and have the customer apply them.

Parent topic: [Symbolic FRUs](#)

---

## AJGJQ01

Licensed Internal Code is the failing item. Look for PTFs associated with the reference code and have the customer apply them.

Parent topic: [Symbolic FRUs](#)

---

## AJGLD01

Licensed Internal Code is the failing item. Look for PTFs associated with the reference code and have the customer apply them.

Parent topic: [Symbolic FRUs](#)

---

## AJGJ601

Licensed Internal Code is the failing item. Look for PTFs associated with the reference code and have the customer apply them.

Parent topic: [Symbolic FRUs](#)

---

## AJGW701

Licensed Internal Code is the failing item. Look for PTFs associated with the reference code and have the customer apply them.

Parent topic: [Symbolic FRUs](#)

---

## AJLAF01

Licensed Internal Code is the failing item. Look for PTFs associated with the reference code and have the customer apply them.

Parent topic: [Symbolic FRUs](#)

---

## AJLAG01

Licensed Internal Code is the failing item. Look for PTFs associated with the reference code and have the customer apply them.

Parent topic: [Symbolic FRUs](#)

---

## AJLYC01

Licensed Internal Code is the failing item. Look for PTFs associated with the reference code and have the customer apply them.

Parent topic: [Symbolic FRUs](#)

---

## AJLYD01

Licensed Internal Code is the failing item. Look for PTFs associated with the reference code and have the customer apply them.

Parent topic: [Symbolic FRUs](#)

---

## AJSDJ01

Licensed Internal Code is the failing item. Look for PTFs associated with the reference code and have the customer apply them.

Parent topic: [Symbolic FRUs](#)

---

## ALTMANL

An Integrated server (IXS) for service call may be needed to fix the problem on the IXS.

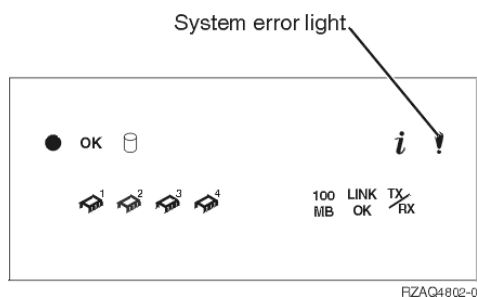
**Note:** An error condition is indicated by the blinking frame ID on the IXS card. When an error occurs, it can take up to ten minutes for the frame ID to start blinking, and up to one minute (after the error is reset) for the frame ID to stop blinking.

Use the following table to find instructions for the reference code you are experiencing.

Table 1. IXS reference codes and instructions

| Reference code | Instructions                                                                                                                                                                                                                                                                                                                                                                                                                                             |
|----------------|----------------------------------------------------------------------------------------------------------------------------------------------------------------------------------------------------------------------------------------------------------------------------------------------------------------------------------------------------------------------------------------------------------------------------------------------------------|
| 1xxx-8910      | <p>Check the system error light (amber exclamation point, see figure below) on the IXS panel.</p> <ul style="list-style-type: none"> <li>• If the system error light is on, call the customer's IXS service provider.</li> <li>• If the system error light is not on, see <a href="#">TWRCARD</a>.</li> </ul> <p><b>Note:</b> Removal of the ac line cord on the IXS unit is required to reset the flashing frame-indicating LEDs on the tower card.</p> |

|           |                                                                                                                                                                                             |
|-----------|---------------------------------------------------------------------------------------------------------------------------------------------------------------------------------------------|
| 1xxx-8920 | <p>Call the customer's IXS service provider.</p> <p><b>Note:</b> Removal of the AC line cord on the IXS unit is required to reset the flashing frame-indicating LEDs on the tower card.</p> |
|-----------|---------------------------------------------------------------------------------------------------------------------------------------------------------------------------------------------|



This ends the procedure.

Parent topic: [Symbolic FRUs](#)

## AMBTEMP

The system detected a room ambient over-temperature warning or fault.

1. Is the room ambient temperature within normal range (less than 35 degrees C or 95 degrees F)?
  - ◆ **No:** Notify the customer. The customer must bring the room temperature within normal range.
  - ◆ **Yes:** Continue with the next step.
2. Are the system front and rear doors free of obstructions?
  - ◆ **No:** Notify the customer. The system must be free of obstructions for proper air flow.
  - ◆ **Yes:** Continue with the next step.
3. Do all the positions in the processor subsystem contain processors or fillers?
  - ◆ **Yes:** Continue with the next step.
  - ◆ **No:** Fill any open positions with processors or fillers. Then go to [Verifying the repair](#). **This ends the procedure.**
4. Do all the power supply positions contain power supplies or fillers?
  - ◆ **Yes:** Continue with the next step.
  - ◆ **No:** Fill any open positions with supplies or fan books. Then go to [Verifying the repair](#). **This ends the procedure.**
5. Are you working with reference code 7201?
  - ◆ **Yes: This ends the procedure.**
  - ◆ **No:** Continue with the next step.
6. Are you working with reference code 7200?
  - ◆ **Yes:** Refer to the reference code error log for failing rack/unit location information, and then continue to next step. For information on displaying error logs refer to [Displaying error and event logs](#)
  - ◆ **No:** Continue with the next step.
7. Perform the following:
  - ◆ **For models ESCALA PL 250R-VL or ESCALA PL 450R-XS, ESCALA PL 250R-L, PL 250R-L+ or PL 450R-VL+, ESCALA PL 250T/R, PL 250T/R+ or PL 450T/R-L+, ESCALA PL 450T/R, PL 450T/R+ or PL 850T/R-L+, 7/20,** exchange the control panel (see [CTLPNL](#)). Then continue with the next step.
  - ◆ **For models ESCALA PL 1650R-L+ and ESCALA PL 850R/PL 1650R/R+,** exchange processor 1 and processor 2, one at a time, until either the problem is resolved or you have replaced both processors (see [Finding part locations](#)). Then continue with the next step.
8. After each FRU is exchanged, is the error code that sent you to this procedure still reported?
  - ◆ **No:** The problem has been corrected. Go to [Verifying the repair](#). **This ends the procedure.**

- ◆ **Yes:** Replace the next FRU on the list. If all FRUs on the list have been replaced, call your next level of support. **This ends the procedure.**

Parent topic: [Symbolic FRUs](#)

---

## AMBTMP1

Ambient air temperature is too high for optimal performance.

Air used for cooling the unit is above the temperature at which the unit is designed to run at maximum performance. The following checks will help determine the problem:

- If the room temperature is above the specified range for the unit reporting this problem, then take steps to lower the room temperature.
- If the temperature of the air being drawn into the unit is above the specified range, either move the unit to a place where the air is within range, or take steps to reduce the temperature of the air surrounding the unit. This can be accomplished by moving the source of the air that is too warm.
- If the temperature of the air at the unit's air intake is within the range specified contact your next level of support.

Parent topic: [Symbolic FRUs](#)

---

## AMBTMP2

Ambient air temperature is back within range.

Ambient air temperature entering the system unit has returned to the nominal operational range for maximum performance. This message and/or symbolic FRU results when the temperature of the air entering the unit was previously reported to be above the unit's specified range. This message and/or symbolic FRU is issued when the unit detects that the ambient air temperature has dropped to within the specified range for maximum performance. No action is necessary.

Parent topic: [Symbolic FRUs](#)

---

## ANYBRDG

Find the location of the card reporting the problem and its corresponding PCI bridge set. Any cable, card, or card enclosure not necessarily the card that reported the problem connected to the PCI bridge set may be causing the problem.

Parent topic: [Symbolic FRUs](#)

---

## ANYBUS

Any cable, card, or card enclosure may be causing an IOP-detected bus error, although the IOP that is reporting the problem may not be causing the problem.

Parent topic: [Symbolic FRUs](#)

---

## ANYFC

Any IOA, hub, gateway, or device attached to the same Fibre Channel interface may be failing.

Parent topic: [Symbolic FRUs](#)

## ANYPROC

The failing component is one of the system processors.

Use the table below to determine what FRU to replace and how to replace it.

**Note:** To simplify this information, secondary units on the ESCALA PL 850R/PL 1650R/R+ server are numbered 1 through 3-secondary unit 1 being nearest to the primary unit and secondary unit 3 being furthest.

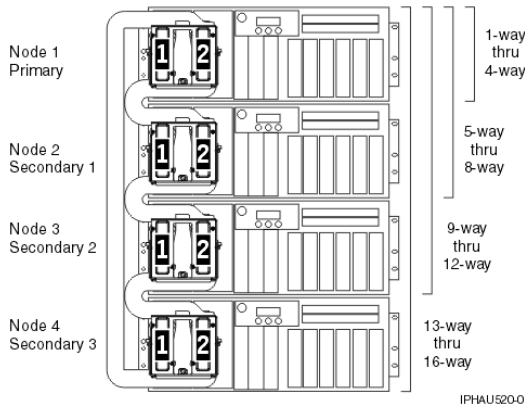


Table 1. ANYPROC failing components

| System model                           | Name of symbolic FRU to locate | FRU name (replace in order, one at a time)                                                                       | Link to locations information                                                          |
|----------------------------------------|--------------------------------|------------------------------------------------------------------------------------------------------------------|----------------------------------------------------------------------------------------|
| ESCALA PL 250R-VL or ESCALA PL 450R-XS | ANYPROC                        | System backplane                                                                                                 | <a href="#">Locations</a> <a href="#">model ESCALA PL 250R-VL or ESCALA PL 450R-XS</a> |
| ESCALA PL 250R-L                       | ANYPROC                        | System backplane                                                                                                 | <a href="#">Locations</a> <a href="#">model ESCALA PL 250R-L</a>                       |
| ESCALA PL 250T/R                       | ANYPROC                        | System backplane                                                                                                 | <a href="#">Locations</a> <a href="#">Model ESCALA PL 250T/R</a>                       |
| ESCALA PL 450T/R                       | ANYPROC                        | Processor card 1<br>Processor card 2                                                                             | <a href="#">Locations</a> <a href="#">Model ESCALA PL 450T/R</a>                       |
| ESCALA PL 850R/PL 1650R/R+             | ANYPROC                        | For each unit, starting with the primary unit and then the secondary units: Processor card 1<br>Processor card 2 | <a href="#">Locations</a> <a href="#">Model ESCALA PL 850R/PL 1650R/R+</a>             |
| 5/75                                   | ANYPROC                        | Processor backplane                                                                                              | <a href="#">Locations</a> <a href="#">model 5/75</a>                                   |
| ESCALA PL 3250R and ESCALA PL 6450R    | ANYPROC                        | For each node, starting with node 0: MCM<br>OMCM 1                                                               | <a href="#">Locations</a> <a href="#">model ESCALA PL 3250R and ESCALA PL 6450R</a>    |

This ends the procedure.

Parent topic: [Symbolic FRUs](#)

---

## AS4NTDD

The Windows server application processor device driver may be causing the problem.

Contact your next level of support for assistance.

Parent topic: [Symbolic FRUs](#)

---

## AUXCBL

Replace the SCSI cable that connects the auxiliary cache I/O adapter to the storage I/O adapter.

1. Are you working on a 571F/575B combination storage and auxiliary cache IOA card set (uses two card slot locations)?
  - ◆ **Yes:** This symbolic FRU does not apply. The SCSI cable is not a FRU on this card set. Go to the next item in the failing item list. **This ends the procedure.**
  - ◆ **No:** Continue with the next step.
2. Find the location of the auxiliary cache I/O adapter:
  - a. Determine the address of the auxiliary cache I/O adapter. See [System reference code \(SRC\) address formats](#).
  - b. Determine the location of the auxiliary cache I/O adapter. See [Finding part locations](#) for the model you are working on.
3. Replace the SCSI cable that connects the auxiliary cache I/O adapter to the storage I/O adapter. See [Part number catalog](#) for cable part number information.

**This ends the procedure.**

**Note:** In order to replace the SCSI cable concurrently, you **must** use concurrent maintenance to power off the auxiliary cache I/O adapter. Replace the cable and then use concurrent maintenance to power on the auxiliary cache I/O adapter. **Do NOT replace the cable when both adapters are powered on.**

Parent topic: [Symbolic FRUs](#)

---

## AUXIOA

Replace the auxiliary I/O adapter.

If you are working on a 571F/575B combination storage and auxiliary cache IOA card set, which uses two card slot locations, then replace the entire card set.

Use the location information in the Service Action Log, if it is available. If the location information is not available, determine the address of the auxiliary cache I/O adapter. See [System reference code \(SRC\) address formats](#). Use the address to find the location (see [Finding part locations](#)).

Parent topic: [Symbolic FRUs](#)

---

## BACKPLN

A backplane or a connection to the backplane may be failing. Use this procedure to identify which backplane may be failing.

**Note:** Before replacing any parts, verify the connections to the backplane.

1. Were you sent here by a power reference code (1xxx xxxx)?
  - ◆ **No:** Continue with the next step.
  - ◆ **Yes:** Go to [SYSBKPL](#). **This ends the procedure.**
2. Determine the location of the device by performing the following:
  - a. Use the location information in the error log if it is available. If no location information for the device is available, use the location information for the I/O adapter instead.
  - b. If no location information is available for either the device or the I/O adapter, find the address of the device or I/O adapter (see [System reference code \(SRC\) address formats](#)). Use the address to find the location (see [Finding part locations](#)).
  - c. Use [Cables](#) to locate the device, cable, and backplane. Any backplane connecting the device or I/O adapter may be the cause of the problem. For backplane part numbers and remove and replace procedures, see [Finding part locations](#).

**This ends the procedure.**

Parent topic: [Symbolic FRUs](#)

---

## BATRY

The battery may be the failing item.

**Note:** When a part number is displayed on the control panel of a system or expansion unit, replace that part first.

The failing battery is in a 50/74 or 50/79 expansion I/O tower. The battery includes all four battery power units. See [Finding part locations](#) before exchanging the battery.

**This ends the procedure.**

Parent topic: [Symbolic FRUs](#)

---

## BKPLEXT

Use this procedure when replacing the backplane extender on ESCALA PL 850R/PL 1650R/R+, ESCALA PL 3250R, or an ESCALA PL 6450R.

The failing component is the backplane extender. Use the following table to determine what FRU to replace and how to replace it.



| System model                                 | Name of symbolic FRU to locate | FRU name (Replace FRUs one at a time, in the order listed, from top to bottom.) | Link to locations information                                                     |
|----------------------------------------------|--------------------------------|---------------------------------------------------------------------------------|-----------------------------------------------------------------------------------|
| ESCALA PL 850R/PL 1650R/R+                   | BKPLEXT                        | Regulator distribution connection backplane                                     | <a href="#">Locations model ESCALA PL 1650R-L+ and ESCALA PL 850R/PL 1650R/R+</a> |
| Multiple 5/70's sequentially cabled together | BKPLEXT                        | <b>Primary unit:</b> Regulator distribution connection backplane                | <a href="#">Locations model ESCALA PL 1650R-L+ and ESCALA PL 850R/PL 1650R/R+</a> |
|                                              |                                | <b>Secondary unit 1:</b> Regulator distribution connection backplane            |                                                                                   |
|                                              |                                | <b>Secondary unit 2:</b> Regulator distribution connection backplane            |                                                                                   |
|                                              |                                | <b>Secondary unit 3:</b> Regulator distribution connection backplane            |                                                                                   |
| 5/75                                         | BKPLEXT                        | Processor backplane                                                             | <a href="#">../iphau/loc575.htm</a>                                               |
| ESCALA PL 3250R, ESCALA PL 6450R             | BKPLEXT                        | Node 0 backplane<br>Node 1 backplane<br>Node 2 backplane<br>Node 3 backplane    | <a href="#">../iphau/loc590.htm</a>                                               |

Parent topic: [Symbolic FRUs](#)

## BRDGSET

The multi-adapter bridge hardware is having a problem with one or more PCI cards or adapters in the PCI bridge set, but the exact card or adapter cannot be identified.

The problem may be with a card, a card slot, or an embedded adapter. The PCI bridge set is indicated by the Direct Select Address (DSA) in word 7 of the reference code. This symbolic FRU only appears in the serviceable event user interface when the LIC could not determine which PCI bridge set has the problem.

- Are you working from a serviceable event user interface of an operating system, service processor, or the HMC that is giving you a card position or list of card positions for this FRU?
  - ◆ **Yes:** Go to step 5.

**Note:** When there is a list of locations in this FRU's location code, the card locations will be separated by commas. A range of card positions will show the starting card position, a colon, and the ending card position.

- ◆ **No:** Perform the following:
  - ◇ Determine the location of the cards in the group using the DSA. Record the DSA (word 7 of the reference code) from the user interface you are using.
  - ◇ Locate the card(s) specified in the DSA by going to [MABIP53](#). Return here and continue with the next step after locating the card(s).
- Did [MABIP53](#) identify a single card location?
  - ◆ **Yes:** This is the location of the failing item. Go to step 5.

- ◆ No: Perform the following (refer to [Removing and replacing parts](#) and the [table below](#)):
  - a. Remove all of the adapter and/or IOP cards in the locations that are identified in the given range of card slots. Do not remove any FRUs with embedded adapters, only FRUs in PCI card slots.
  - b. Replace each card one at a time. Power on the unit after you replace each card until either the problem reappears or you have replaced each card. Then continue with the next step.
- 3. Did the problem reappear?
  - ◆ **Yes:** The last card that you replaced before the problem reappeared is the failing item. **This ends the procedure.**
  - ◆ **No:** Continue with the next step.
- 4. Did [MABIP53](#) identify a FRU with embedded adapters?
  - ◆ **Yes:** The problem is in the FRU with the embedded adapter. Continue with the next step and exchange that FRU using the following table to link to the service information for that FRU.
  - ◆ **No:** The problem may be intermittent. Contact your next level of support. **This ends the procedure.**
- 5. Use the links in the following table to locate and replace the failing item(s).

Table 1. Failing items for symbolic FRU BRDGSET

| Model, expansion unit, or machine type | Symbolic FRU to locate                                       | Link to locations information                                           |
|----------------------------------------|--------------------------------------------------------------|-------------------------------------------------------------------------|
| ESCALA PL 250R-VL or ESCALA PL 450R-XS | BRDGSET                                                      | <a href="#">Locations model ESCALA PL 250R-VL or ESCALA PL 450R-XS</a>  |
| ESCALA PL 250T/R                       | BRDGSET                                                      | <a href="#">Locations model ESCALA PL 250T/R</a>                        |
| ESCALA PL 450T/R                       | BRDGSET                                                      | <a href="#">Locations model ESCALA PL 450T/R</a>                        |
| ESCALA PL 850R/PL 1650R/R+             | BRDGSET for correct system unit (the primary or a secondary) | <a href="#">Locations model ESCALA PL 850R/PL 1650R/R+</a>              |
| 50/74, 8079-002, 8093-002              | BRDGSET                                                      | <a href="#">Locations 50/74, 8079-002, and 8093-002 expansion units</a> |
| 50/79                                  | BRDGSET                                                      | <a href="#">Locations 50/79 expansion unit</a>                          |
| 50/88, 05/88                           | BRDGSET                                                      | <a href="#">Locations 50/88 and 05/88 expansion units</a>               |
| 50/94, 52/94, 8094-002                 | BRDGSET                                                      | <a href="#">Locations 50/94, 52/94, and 8094-002 expansion units</a>    |
| 50/95, 05/95                           | BRDGSET                                                      | <a href="#">Locations 50/95 and 05/95 expansion units</a>               |
| Type 1519 external xSeries server      | BRDGSET                                                      | <a href="#">Locations Integrated xSeries adapter card (IXA)</a>         |
| 11D/10, 11D/11, and 57/90              | BRDGSET                                                      | <a href="#">Locations 11D/10, 11D/11, and 57/90 expansion units</a>     |
| 11D/20                                 | BRDGSET                                                      | <a href="#">Locations 11D/20 expansion unit</a>                         |
| 57/91, 57/94, and 406/1D               | BRDGSET                                                      | <a href="#">Locations 57/91, 57/94, and 406/1D expansion units</a>      |

**This ends the procedure.**

Parent topic: [Symbolic FRUs](#)

---

## BRDGST1

The multi-adapter bridge hardware is having a problem with one or more PCI cards or adapters in the first PCI bridge set in the enclosure, but the exact card or adapter cannot be identified.

The problem can be with a card, a card slot, or an embedded adapter. The PCI bridge set is indicated by the Direct Select Address (DSA) in word 7 of the reference code.

1. Are you working from a serviceable event user interface of an operating system, service processor, or the HMC and there is a card position or list of card positions given for this FRU?
  - ◆ **Yes:** Then the position(s) given is the location of the failing component(s). When there is a list of locations in this FRU's location code, the card locations will be separated by commas. A range of card positions will show the starting card position, a colon, and the ending card position. Go to step 5.
  - ◆ **No:** Perform the following:
    - a. Determine the location of the cards in the group using the DSA. Record the DSA, which is word 7 of the reference code, from the user interface you are using.
    - b. Locate the card(s) specified in the DSA by going to [MABIP53](#). Return here after locating the card or cards and continue with the next step.
2. Were you able to identify a single card position by performing [MABIP53](#)?
  - ◆ **Yes:** This is the location of the failing item. Go to step 5.
  - ◆ **No:** Continue with the next step.
3. Perform the following, referring to the removal and replacement procedures for each FRU location you determined (you can find links to the locations information, and from there to the removal and replacement procedures, in the table at the end of this procedure):
  - a. Remove all of the adapter and/or IOP cards in the locations that are identified in the given range of card slots. Do not remove any FRUs with embedded adapters, only FRUs in PCI card slots.
  - b. Replace each card one at a time.

**Note:** For adapters controlled by IOPs, replace the IOP before any of the adapters.

Power on the unit (as instructed in the removal and replacement procedure indicated by following the link in the following table) after you replace each card until either the problem reappears or you have replaced each card.

- c. Did the problem reappear?
  - ◆ **Yes:** The last card that you replaced before the problem appeared again is the failing item. This ends the procedure.
  - ◆ **No:** Continue with the next step.
4. Did you identify a FRU with embedded adapters when performing [MABIP53](#)?
  - ◆ **Yes:** The problem is in the FRU with the embedded adapter. Continue with the next step and exchange that FRU.
  - ◆ **No:** The problem may be intermittent. Contact your next level of support. This ends the procedure.
5. Use the links in the following table to locate and replace the failing item(s).

Table 1. Failing item for symbolic FRU BRDGST1

| System model, expansion unit, or machine type | Symbolic FRU to locate | FRU name                                     | Link to locations                                                                       |
|-----------------------------------------------|------------------------|----------------------------------------------|-----------------------------------------------------------------------------------------|
| ESCALA PL 250R-VL or ESCALA PL 450R-XS        | BRDGST1                | System backplane                             | <a href="#">Locations</a> <a href="#">model ESCALA PL 250R-VL or ESCALA PL 450R-XS</a>  |
| ESCALA PL 250T/R                              | BRDGST1                | PCI bridge set 1                             | <a href="#">Locations</a> <a href="#">model ESCALA PL 250T/R</a>                        |
| ESCALA PL 450T/R                              | BRDGST1                | PCI bridge set 1                             | <a href="#">Locations</a> <a href="#">model ESCALA PL 450T/R</a>                        |
| ESCALA PL 850R/PL 1650R/R+                    | BRDGST1                | PCI bridge set 1 (for correct system unit)   | <a href="#">Locations</a> <a href="#">model ESCALA PL 850R/PL 1650R/R+</a>              |
| 50/74, 8079-002, 8093-002                     | BRDGST1                | PCI bridge set 1                             | <a href="#">Locations</a> <a href="#">50/74, 8079-002, and 8093-002 expansion units</a> |
| 50/79                                         | BRDGST1                | PCI bridge set 1                             | <a href="#">Locations</a> <a href="#">50/79 expansion unit</a>                          |
| 50/88, 05/88                                  | BRDGST1                | PCI bridge set 1                             | <a href="#">Locations</a> <a href="#">50/88 and 05/88 expansion units</a>               |
| 50/94, 52/94, 8094-002                        | BRDGST1                | PCI bridge set 1                             | <a href="#">Locations</a> <a href="#">50/94, 52/94, and 8094-002 expansion units</a>    |
| 50/95, 05/95                                  | BRDGST1                | PCI bridge set 1                             | <a href="#">Locations</a> <a href="#">50/95 and 05/95 expansion units</a>               |
| Type 1519 external xSeries server             | BRDGST1                | Follow RIO/HSL cable                         | <a href="#">Locations</a> <a href="#">Integrated xSeries adapter card (IXA)</a>         |
| 11D/10, 11D/11, and 57/90                     | BRDGST1                | PCI bridge set 1                             | <a href="#">Locations</a> <a href="#">11D/10, 11D/11, and 57/90 expansion units</a>     |
| 11D/20                                        | BRDGST1                | PCI bridge set 1                             | <a href="#">Locations</a> <a href="#">11D/20 expansion unit</a>                         |
| 57/91, 57/94, and 406/1D                      | BRDGST1                | PCI bridge set 1 on backplane 1 (left side)  | <a href="#">Locations</a> <a href="#">57/91, 57/94, and 406/1D expansion units</a>      |
|                                               | BRDGST1                | PCI bridge set 1 on backplane 2 (right side) |                                                                                         |

Parent topic: [Symbolic FRUs](#)

## BRDGST2

PCI I/O card group in the second PCI bridge set (middle adapter card range when there are three PCI bridge sets and high adapter card range when there are two PCI bridge sets), IOAs and/or IOPs.

The multi-adapter bridge hardware is having a problem with one or more PCI cards or adapters in the second PCI bridge set in the enclosure, but the exact card or adapter cannot be identified. The problem can be with a card, a card slot, or an embedded adapter. The PCI bridge set is indicated by the Direct Select Address (DSA) in word 7 of the reference code.

1. Are you working from a serviceable event user interface of an operating system, service processor, or the HMC and there is a card position or list of card positions given for this FRU?
  - ◆ **Yes:** Then the position(s) given is the location of the failing component(s). When there is a list

of locations in this FRU's location code, the card locations will be separated by commas. A range of card positions will show the starting card position, a colon, and the ending card position. Go to step 5.

- ◆ **No:** Perform the following:
  - a. Determine the location of the cards in the group using the DSA. Record the DSA, which is word 7 of the reference code, from the user interface you are using.
  - b. Locate the card(s) specified in the DSA by going to [MABIP53](#). Return here after locating the card or cards and continue with the next step.
- 2. Were you able to identify a single card position by performing [MABIP53](#)?
  - ◆ **Yes:** This is the location of the failing item. Go to step 5.
  - ◆ **No:** Continue with the next step.
- 3. Perform the following, referring to the remove and replace procedures for each FRU location you determined (you can find links to the locations information, and from there to the remove and replace procedures, in the table at the end of this procedure):
  - a. Remove all of the adapter and/or IOP cards in the locations that are identified in the given range of card slots. Do not remove any FRUs with embedded adapters, only FRUs in PCI card slots.
  - b. Replace each card one at a time. Power on the unit (as instructed in the remove and replace procedure indicated by following the link in the following table) after you replace each card until either the problem reappears or you have replaced each card.
  - c. Did the problem reappear?
    - ◇ **Yes:** The last card that you replaced before the problem appeared again is the failing item. **This ends the procedure.**
    - ◇ **No:** Continue with the next step.
- 4. Did you identify a FRU with embedded adapters when performing [MABIP53](#)?
  - ◆ **Yes:** The problem is in the FRU with the embedded adapter. Continue with the next step and exchange that FRU.
  - ◆ **No:** The problem may be intermittent. Contact your next level of support. **This ends the procedure.**
- 5. Use the links in the table below to locate and replace the failing item(s).

Table 1. Failing item for symbolic FRU BRDGST2

| System model, expansion unit, or machine type | Symbolic FRU to locate | FRU location                                                    | Link to locations                                                       |
|-----------------------------------------------|------------------------|-----------------------------------------------------------------|-------------------------------------------------------------------------|
| ESCALA PL 250T/R                              | BRDGST2                | PCI bridge set 2                                                | <a href="#">Locations model ESCALA PL 250T/R</a>                        |
| ESCALA PL 450T/R                              | BRDGST2                | PCI bridge set 2                                                | <a href="#">Locations model ESCALA PL 450T/R</a>                        |
| ESCALA PL 850R/PL 1650R/R+                    | BRDGST2                | PCI bridge set 2 for correct system unit (primary or secondary) | <a href="#">Locations model ESCALA PL 850R/PL 1650R/R+</a>              |
| 50/74, 8079-002, 8093-002                     | BRDGST2                | PCI bridge set 2                                                | <a href="#">Locations 50/74, 8079-002, and 8093-002 expansion units</a> |
| 50/79                                         | BRDGST2                | PCI bridge set 2                                                | <a href="#">Locations 50/79 expansion unit</a>                          |
| 50/88, 05/88                                  | BRDGST2                | PCI bridge set 2                                                | <a href="#">Locations 50/88 and 05/88 expansion units</a>               |
| 50/94, 52/94, 8094-002                        | BRDGST2                | PCI bridge set 2                                                | <a href="#">Locations 50/94, 52/94, and 8094-002 expansion units</a>    |
| 50/95, 05/95                                  | BRDGST2                | PCI bridge set 2                                                | <a href="#">Locations 50/95 and 05/95 expansion units</a>               |
| Type 1519 external xSeries server             | BRDGST2                | Follow RIO/HSL cable                                            | <a href="#">Locations Integrated xSeries adapter card (IXA)</a>         |
| 11D/10, 11D/11, and 57/90                     | BRDGST2                | PCI bridge set 2                                                | <a href="#">Locations 11D/10 and 11D/11 and 57/90 expansion unit</a>    |

|                          |         |                                              |                                                                   |
|--------------------------|---------|----------------------------------------------|-------------------------------------------------------------------|
| 11D/20                   | BRDGST2 | PCI bridge set 2                             | <a href="#">Locations 11D/20 expansion unit</a>                   |
| 57/91, 57/94, and 406/1D | BRDGST2 | PCI bridge set 2 on backplane 1 (left side)  | <a href="#">Locations 57/91, 57/94, and 406/1D expansion unit</a> |
|                          | BRDGST2 | PCI bridge set 2 on backplane 2 (right side) |                                                                   |

**This ends the procedure.**

Parent topic: [Symbolic FRUs](#)

---

## BRDGST3

PCI I/O card group in the third PCI bridge set (highest adapter card range), IOAs and/or IOPs.

The multi-adapter bridge hardware is having a problem with one or more PCI cards or adapters in the third PCI bridge set in the enclosure, but the exact card or adapter cannot be identified. The problem can be with a card, a card slot, or an embedded adapter. The PCI bridge set is indicated by the Direct Select Address (DSA) in word 7 of the reference code.

1. Are you working from a serviceable event user interface of an operating system, service processor, or the HMC, and there is a card position or list of card positions given for this FRU?
  - ◆ **Yes:** Then the position(s) given is the location of the failing component(s). When there is a list of locations in this FRU's location code, the card locations will be separated by commas. A range of card positions will show the starting card position, a colon, and the ending card position. Go to step 5.
  - ◆ **No:** Perform the following:
    - a. Determine the location of the cards in the group using the DSA. Record the DSA, which is word 7 of the reference code, from the user interface you are using.
    - b. Locate the card(s) specified in the DSA by going to [MABIP53](#). Return here after locating the card or cards and continue with the next step.
2. Were you able to identify a single card position by performing [MABIP53](#)?
  - ◆ **Yes:** This is the location of the failing item. Go to step 5.
  - ◆ **No:** Continue with the next step.
3. Perform the following, referring to the remove and replace procedures for each FRU location you determined (you can find links to the locations information, and from there to the remove and replace procedures, in the table at the end of this procedure):
  - a. Remove all of the adapter and/or IOP cards in the locations that are identified in the given range of card slots. Do not remove any FRUs with embedded adapters, only FRUs in PCI card slots.
  - b. Replace each card one at a time.

**Note:** For adapters controlled by IOPs, replace the IOP before any of the adapters.

Power on the unit (as instructed in the remove and replace procedure indicated by following the link in the following table) after you replace each card until either the problem reappears or you have replaced each card.

- c. Did the problem reappear?
  - ◆ **Yes:** The last card that you replaced before the problem appeared again is the failing item. **This ends the procedure.**
  - ◆ **No:** Continue with the next step.

4. Did you identify a FRU with embedded adapters when performing [MABIP53](#)?
  - ◆ **Yes:** The problem is in the FRU with the embedded adapter. Continue with the next step and exchange that FRU.
  - ◆ **No:** The problem may be intermittent. Contact your next level of support. **This ends the procedure.**
5. Use the links in the following table below to locate and replace the failing item(s).

Table 1. Failing item for symbolic FRU BRDGST3

| System model, expansion unit, or machine type | Symbolic FRU to locate | FRU name                                        | Link to locations                                                                           |
|-----------------------------------------------|------------------------|-------------------------------------------------|---------------------------------------------------------------------------------------------|
| ESCALA PL 250T/R                              | BRDGST3                | PCI bridge set 3                                | <a href="#">Locations</a> <a href="#">Model ESCALA PL 250T/R</a>                            |
| ESCALA PL 450T/R                              | BRDGST3                | PCI bridge set 3                                | <a href="#">Locations</a> <a href="#">Model ESCALA PL 450T/R</a>                            |
| ESCALA PL 850R/PL 1650R/R+                    | BRDGST3                | PCI bridge set 3 (on primary or secondary unit) | <a href="#">Locations</a> <a href="#">Model ESCALA PL 850R/PL 1650R/R+</a>                  |
| 50/74, 8079-002, 8093-002                     | BRDGST3                | PCI bridge set 3                                | <a href="#">Locations</a> <a href="#">50/74, 8079-002, and 8093-002 expansion I/O units</a> |
| 50/79                                         | BRDGST3                | PCI bridge set 3                                | <a href="#">Locations</a> <a href="#">50/79 expansion I/O unit</a>                          |
| 50/88, 05/88                                  | BRDGST3                | PCI bridge set 3                                | <a href="#">Locations</a> <a href="#">50/88 and 05/88 expansion I/O units</a>               |
| 50/94, 52/94, 8094-002                        | BRDGST3                | PCI bridge set 3                                | <a href="#">Locations</a> <a href="#">50/94, 52/94, and 8094-002 expansion I/O units</a>    |
| Type 1519 external xSeries server             | BRDGST3                | Follow RIO/HSL cable                            | <a href="#">Locations</a> <a href="#">Integrated xSeries adapter card (IXA)</a>             |
| 57/91, 57/94, and 406/1D                      | BRDGST3 (left side)    | PCI bridge set 3 on backplane 1                 | <a href="#">Locations</a> <a href="#">57/91, 57/94, and 406/1D expansion unit</a>           |
|                                               | BRDGST3 (right side)   | PCI bridge set 3 on backplane 2                 |                                                                                             |

**This ends the procedure.**

Parent topic: [Symbolic FRUs](#)

---

## BPC

The Bulk power controller (BPC) may be failing.

1. Is the SRC 1xxx-8735?
  - ◆ **No:** Continue with the next step.
  - ◆ **Yes:** Go to [HMC isolation procedures](#). Once you verify that the communications is working, return here. Verify that the communications cables are connected and properly routed between the Hardware Management Console (HMC), BPC, and the service processor. See [Model ESCALA PL 3250R and ESCALA PL 6450R cables](#). (For model 5/75, that has a BPH between the BPC and the service processor, verify that the BPC is connected and functioning. See [Model 5/75 cables](#).) For frame to HMC cables, see [External cables](#). If you still have the problem, replace the BPC. (Go to [Locations](#) [model 5/75](#) or [Locations](#) [model ESCALA PL 3250R and ESCALA PL 6450R](#).)

**Note:** If you are getting a 8 8721 Refcode:

**F:**

- ◆ Ensure all HubA (T5) ethernet cables on the Service Processors are routed to the same BPA on one side of the system and HubB (T6) cables are routed to the other BPA.

**For 590/595:**

- ◆ Ensure Service Processor J3 ethernet cables are routed to the BPA on one side of the system and J4 cables to the BPA (if present) on the opposite side.

Communications problems will result if cabling is mixed during repair or installation.

2. Use the following table to perform the appropriate action for the SRC you are working with.

| SRC                  | Replace this FRU | Link to locations information                                                                                               |
|----------------------|------------------|-----------------------------------------------------------------------------------------------------------------------------|
| 1xxx8 1xxx8740       | BPC A (front)    | <a href="#">Locations model 5/75</a> or <a href="#">Locations model ESCALA PL 3250R</a> and <a href="#">ESCALA PL 6450R</a> |
| 1xxx8721 or 1xxx8741 | BPC B (rear)     |                                                                                                                             |

**This ends the procedure.**

Parent topic: [Symbolic FRUs](#)

## Model ESCALA PL 3250R, PL 3250R+, ESCALA PL 6450 or PL 6450R+ cables

Power cables.

Table 1. Model ESCALA PL 3250R, ESCALA PL 6450R, and 9406-595 cables

| Name | Description                                               | Part number |
|------|-----------------------------------------------------------|-------------|
|      | 14' power cord, 200-240 V, 10 A                           | 36L8877     |
|      | 9' power cord, 200-240 V, 15 A                            | 39M5254     |
|      | 9' power cord, 100-127 V, 15 A                            | 39M5247     |
|      | 14' power cord, right angle, 200-240 V, 10 A              | 13F9995     |
|      | 9' power cord, 250 V, 10 A                                | 39K4947     |
|      | 14' power cord, right angle, 200-240 V, 10 A              | 14F0013     |
|      | 4.3 meter power cord, 200 V, 10 A, Denmark                | 13F9998     |
|      | 14' power cord, right angle, 200-240 V 10 A               | 13F9977     |
|      | 14' power cord, 200-240 V, 15 A, IEC320/C19               | 39M5367     |
|      | 14' power cord, 200-240 V, 15 A, IEC320/C13               | 39M5096     |
|      | 14' power cord, 200-240 V, 15 A, IEC320/C13               | 39M5187     |
|      | 14' power cord, right angle, 200-240 V, 10 A, IEC320/C13, | 6952287     |
|      | 14' power cord, right angle, 200-240 V, 10 A, IEC320/C13  | 14F0031     |
|      | 14' power cord, right angle, 200-240 V, 10 A, IEC320/C13  | 14F0049     |



|  |                                                          |         |
|--|----------------------------------------------------------|---------|
|  | 14' power cord, right angle, 200-240 V, 10 A, IEC320/C13 | 02K0544 |
|  | 14' power cord, 127 V, 15 A                              | 39M5200 |
|  | 14' power cord, 200-240 V, 10 A                          | 39M5331 |
|  | 14' power cord, 200-240 V, 12 A                          | 39M5335 |
|  | 14' power cord, 200-240 V, 15 A, IEC320/C19              | 39M5359 |
|  | 14' power cord, right angle, 200-240 V, 10 A, IEC320/C13 | 74P4422 |

Parent topic: [Power and signal cables](#)

---

## Model 5/75 cables

Power cables.

Table 1. Model 185/75 - cables

| Name | Description                             | Part number |
|------|-----------------------------------------|-------------|
|      | 9' power cord 250 V 10 A                | 39M5151     |
|      | 9' power cord, 250 V, 10 A              | 39M5219     |
|      | 9' power cord, 200-240 V, 15 A          | 39M5254     |
|      | 9' power cord, 250 V, 10 A              | 39M5226     |
|      | 9' power cord, 250 V, 10 A              | 39M5165     |
|      | 9' power cord, 100-127 V, 15 A          | 39M5247     |
|      | 9' power cord, 250 V, 10 A              | 39K4947     |
|      | 9' power cord, 250 V, 10 A, IEC320/C13, | 39M5158     |

Parent topic: [Power and signal cables](#)

---

## External cables

Choose the type of external cable you are working with:

- [General external cables](#)
- [External ac line cords](#)

Table 1. General external cables

| Description                             | Units | Part number |
|-----------------------------------------|-------|-------------|
| (Ethernet cable, 6M)                    |       | 16R0449     |
| (Ethernet cable, 15M)                   |       | 05N5292     |
| Internal modem cable (FC1010) - Austria |       | 39J5818     |
| Internal modem cable (FC1011) - Belgium |       | 39J5819     |
| Internal modem cable (FC1012) - Africa  |       | 39J5808     |
| Internal modem cable (FC1013) - Israel  |       | 21H4905     |
| Internal modem cable (FC1014) - Italy   |       | 39J5809     |

## Service provider information

|                                                |  |         |
|------------------------------------------------|--|---------|
| Internal modem cable (FC1015) - France         |  | 39J5810 |
| Internal modem cable (FC1016) - Germany        |  | 39J5811 |
| Internal modem cable (FC1017) - UK             |  | 39J5817 |
| Internal modem cable (FC1018) - Iceland/Sweden |  | 39J5812 |
| Internal modem cable (FC1019) - Australia      |  | 39J5813 |
| Internal modem cable (FC1020) - HK/NZ          |  | 39J5817 |
| Internal modem cable (FC1021) - Finland/Norway |  | 39J5815 |
| Internal modem cable (FC1022) - Netherlands    |  | 39J5816 |
| Internal modem cable (FC1023) - Switzerland    |  | 39J5806 |
| Internal modem cable (FC1024) - Denmark        |  | 39J5807 |
| Internal modem cable (FC1025) - US/Canada      |  | 42R5087 |
| Cable, token ring (FC2745) 8 feet              |  | 6339098 |
| Cable, Ethernet (FC4723) RJ-45                 |  | 75G2865 |
| Cable, 8 Port Twinax (FC4746)                  |  | 39J5129 |
| Cable, ISDN RJ-45                              |  | 97H7699 |
| Cable, ATM filtered (FC4815)                   |  | 97H7385 |
| Cable, VIDEO EXT (FC0325)                      |  | 44H8676 |
| Cable, mouse, keyboard extension (FC0325)      |  | 44H8677 |
| Keyboard/mouse splitter cable (CCIN 2890)      |  | 42R5187 |
| V/S COMM - 6m cable (031A)                     |  | 44L0007 |
| VSCOM (6 meters) (31B)                         |  | 04N3886 |
| V.24 - 20' cable (0348)                        |  | 39J5825 |
| V.24 - 20' cable - Germany (0348)              |  | 39J5826 |
| V.24 - 20' cable - Japan (0348)                |  | 39J5827 |
| V.24 - 50' cable (0349)                        |  | 44H7481 |
| V.24 - 50' cable - Germany (0349)              |  | 44H7483 |
| V.24 - 50' cable - Japan (0349)                |  | 44H7485 |
| V.24 - 20' cable (0350)                        |  | 44H7486 |
| V.24 - 20' cable - Germany (0350)              |  | 44H7489 |
| V.24 - 20' cable - Japan (0350)                |  | 44H7492 |
| V.24 - 50' cable (0351)                        |  | 44H7487 |
| V.24 - 50' cable - Germany (0351)              |  | 44H7490 |
| V.24 - 50' cable - Japan (0351)                |  | 44H7491 |
| V.24 - 80' cable (0352)                        |  | 44H7488 |
| V.24 - 80' cable - Germany (0352)              |  | 44H7491 |
| V.24 - 80' cable - Japan (0352)                |  | 44H7494 |
| V.35 - 20' cable (0353)                        |  | 39J5828 |
| V.35 - 50' cable (0354)                        |  | 44H7496 |
| V.35 - 80' cable (0355)                        |  | 44H7497 |
| V.36 - 20' cable (0356)                        |  | 39J5829 |
| V.36 - 50' cable (0357)                        |  | 44H7499 |
| V.36 - 80' cable (0358)                        |  | 44H7500 |
| X.21 - 20' cable (0359)                        |  | 39J5830 |
| X.21 - 50' cable (0360)                        |  | 44H7502 |
| RS232 - 80' cable (0365)                       |  | 97H7386 |
| RS232 - 80' cable - Germany (0365)             |  | 97H7387 |
| RS232 - 80' cable - Japan (0365)               |  | 97H7388 |
| cable (3 meters) (1460)                        |  | 39J5833 |
| cable (6 meters) (1461)                        |  | 39J5834 |

## Service provider information

|                                                            |  |         |
|------------------------------------------------------------|--|---------|
| cable (15 meters) (1462)                                   |  | 04N7014 |
| optical cable (6 meters) (1470)                            |  | 42R5270 |
| optical cable (30 meters) (1471)                           |  | 42R5271 |
| optical cable (100 meters) (1472)                          |  | 42R5272 |
| optical cable (250 meters) (1473)                          |  | 42R5273 |
| -2 (6 meters) (1474)                                       |  | 39J2559 |
| -2 (10 meters) (1475)                                      |  | 39J2551 |
| -2 (1.2 meters) (1481, 3146)                               |  | 39J2562 |
| -2 (1.75 meters) (1307, 3156)                              |  | 00P5238 |
| -2 (1.75 meters) (1308, 3158)                              |  | 00P5239 |
| -2 (3.5 meters) (1482, 3147)                               |  | 39J2554 |
| -2 (10 meters) (1483, 3148)                                |  | 21P5456 |
| -2 (15 meters) (1485)                                      |  | 21P5457 |
| (8 meters) (3170)                                          |  | 12R7503 |
| Remote control panel cable                                 |  | 53P5704 |
| Serial-UPS conversion cable 1827                           |  | 39J5836 |
| SPCN cable (2 meters) (1463, 6001)                         |  | 87G6235 |
| SPCN cable (3 meters) (6006)                               |  | 09P1251 |
| SPCN cable (6 meters) (1464, 6008)                         |  | 21F9469 |
| SPCN cable (15 meters) (1465, 6007)                        |  | 21F9358 |
| SPCN cable (30 meters) (1466, 6029)                        |  | 21F9359 |
| SPCN cable (60 meters) (1467)                              |  | 21F9360 |
| Optical SPCN cable (100 meters) (0369)                     |  | 41U0128 |
| Optical SPCN cable (250 meters) (1468)                     |  | 41U0129 |
| SPCN Y-cable                                               |  | 39J5820 |
| RS485 cable                                                |  | 39J5824 |
| J-TAG A cable (033A)                                       |  | 97H7486 |
| J-TAG C cable (033B)                                       |  | 97H7487 |
| J-TAG E cable (033C)                                       |  | 97H7604 |
| 50 micron Fibre Channel conversion cable (0371)            |  | 11P1373 |
| 62.5 micron Fibre Channel conversion cable (0372)          |  | 11P1374 |
| AC Jumper Non-DLC (5094 - 5294 only) A01 to A02            |  | 44H8388 |
| SPCN port cable (frame-to-node)                            |  | 21F9362 |
| Frame-to-frame cable                                       |  | 87G6235 |
| SPCN optical adapter                                       |  | 39J3865 |
| Extender cable for USB keyboards/diskettes, 2 meter (4256) |  | 10N7374 |
| 12x InfiniBand cable (4 meters) (1832)                     |  | 97P3653 |
| 12x InfiniBand cable (6 meters) (1833)                     |  | 97P3654 |
| 12x InfiniBand cable (8 meters) (1834)                     |  | 39J0288 |
| 4x InfiniBand cable (3 meters) (1835)                      |  | 97P6113 |
| 4x InfiniBand cable (8 meters) (1836)                      |  | 21P8318 |
| 12x to three 4x InfiniBand cable (3 meters) (1837)         |  | 97P6114 |
| 12x to three 4x InfiniBand cable (8 meters) (1838)         |  | 21P8319 |

Table 2. External ac line cords

| Description                                             | Units per assembly | Feature code | Length  | Part number |
|---------------------------------------------------------|--------------------|--------------|---------|-------------|
| Line power cord, US, Canada, Japan, 30 AMP 480 V ac 1 2 | 2                  | 1303         | 14 feet | 41U0101     |
| Line power cord, US, Canada, Japan, 60 AMP 240 V ac 1 2 | 2                  | 1301         | 14 feet | 11P0367     |
| Line power cord, US, Chicago, 30 AMP 480 V ac 1 2       | 2                  | 1302         | 6 feet  | 11P0914     |
| Line power cord, US, Chicago, 60 AMP 240 V ac 1 2       | 2                  | 1300         | 6 feet  | 11P0365     |
| World trade line power cord, 50 AMP 240 V ac 2          | 2                  | 1304         | 14 feet | 11P0918     |

Parent topic: [Cables](#)

---

## BPCHANG

The system is stopped on one of the base motherboard controller checkpoints.

If the system hangs on one of the base motherboard controller checkpoints, do the following:

1. Remove the AC cord, then reattach it to the system.
2. Watch the control panel display. If 01 appears in the upper left hand corner of the display, power on the system.

If the system continues to hang on a base motherboard controller checkpoint, replace the system backplane (see [SYSBKP2](#)).

Parent topic: [Symbolic FRUs](#)

---

## BSTWRPL

This symbolic FRU is no longer supported.

Parent topic: [Symbolic FRUs](#)

---

## BUSVPD

This is the VPD (vital product data) for a PCI bus at the multi-adapter bridge end of the primary PCI bus.

1. Are you working from the serviceable event view and a card location is listed with this failing item?
  - ◆ **Yes:** Then the error is at that card location. Continue with the next step.
  - ◆ **No:** Perform the following:
    - a. Record the bus number value (BBBB) from word 7 of the reference code (see [Breaking down a RIO/HSL or PCI bus reference code](#) for help in determining the bus number).
    - b. Search for the bus number in the HMC's or operating system's resource and configuration interfaces, or in the system configuration listing, to determine which unit contains the failing item. Record the frame or unit type and then continue with the next step.
2. Use the following table to determine the appropriate service action.

|                                           |                         |
|-------------------------------------------|-------------------------|
| Frame or unit containing the failing item | Go to this symbolic FRU |
|-------------------------------------------|-------------------------|

#### Service provider information

|                            |                         |
|----------------------------|-------------------------|
| ESCALA PL 250T/R           | <a href="#">SYSBKPL</a> |
| ESCALA PL 850R/PL 1650R/R+ | <a href="#">SYSBKPL</a> |
| 50/74, 8079-002, 8093-002  | <a href="#">TWRPLNR</a> |
| 50/79                      | <a href="#">TWRPLNR</a> |
| 50/88, 05/88               | <a href="#">TWRPLNR</a> |
| 50/94, 52/94, 8094-002     | <a href="#">TWRPLNR</a> |
| 50/95, 05/95               | <a href="#">TWRBKPL</a> |
| External xSeries server    | <a href="#">SIADPCD</a> |
| 57/91, 57/94, and 406/1D   | <a href="#">TWRPLNR</a> |
| 11D/10, 11D/11, and 57/90  | <a href="#">TWRPLNR</a> |
| 11D/20                     | <a href="#">TWRPLNR</a> |

**This ends the procedure.**

**Parent topic:** [Symbolic FRUs](#)

---

## CABLEH

Use this information to perform the appropriate action for the SRC you are working with.

### **DANGER**When working on or around the system, observe the following precautions:

Electrical voltage and current from power, telephone, and communication cables are hazardous. To avoid a shock hazard:

- Connect power to this unit only with the provided power cord. Do not use the provided power cord for any other product.
- Do not open or service any power supply assembly.
- Do not connect or disconnect any cables or perform installation, maintenance, or reconfiguration of this product during an electrical storm.
- The product might be equipped with multiple power cords. To remove all hazardous voltages, disconnect all power cords.
- Connect all power cords to a properly wired and grounded electrical outlet. Ensure that the outlet supplies proper voltage and phase rotation according to the system rating plate.
- Connect any equipment that will be attached to this product to properly wired outlets.
- When possible, use one hand only to connect or disconnect signal cables.
- Never turn on any equipment when there is evidence of fire, water, or structural damage.
- Disconnect the attached power cords, telecommunications systems, networks, and modems before you open the device covers, unless instructed otherwise in the installation and configuration procedures.
- Connect and disconnect cables as described in the following procedures when installing, moving, or opening covers on this product or attached devices.  
To Disconnect:
  1. Turn off everything (unless instructed otherwise).
  2. Remove the power cords from the outlets.
  3. Remove the signal cables from the connectors.
  4. Remove all cables from the devices

To Connect:

1. Turn off everything (unless instructed otherwise).

2. Attach all cables to the devices.
3. Attach the signal cables to the connectors.
4. Attach the power cords to the outlets.
5. Turn on the devices.

(D005)

Use the following table to perform the appropriate action for the SRC you are working with.

**Attention:** Before replacing any cables, ensure that the cables are properly routed and securely plugged.

**Attention:**

1. If you are servicing a BPC and get a 1xxx 8 8721 SRC for any BPC, ignore the error until you have the BPC powered on again.
2. If you are servicing the front BPC and you do not have a redundant HMC, you will not get errors from your 24 inch expansion units until the service is complete.

1. Is the SRC 1xxx-8 8721?
  - ◆ **Yes:** Continue with the next step.
  - ◆ **No:** Go to step 3.
2. Note: If you are getting a 8 8721 Refcode:

**F:**

- ◆ Ensure all HubA (System P1-T5) ethernet cables on the Service Processors are routed to the same BPA on one side of the system and HubB (System P1-T6) cables are routed to the other BPA.

**For 590/595:**

- ◆ Ensure Service Processor J3 ethernet cables are routed to the BPA on one side of the system and J4 cables to the BPA (if present) on the opposite side.

Communications problems will result if cabling is mixed during repair or installation.

In this step you will be measuring voltages on one of the bulk power assemblies (BPAs). If the SRC is 1xxx8720, then you should measure the voltage on BPA-A (front). If the SRC is 1xxx8721, then you should measure the voltage on BPA-B (rear).

Using the labeled test points on the face of the BPA, measure the voltages between the following:

- ◆ phase A and phase B
- ◆ phase B and phase C
- ◆ phase C and phase A

Are all of the meter readings greater than 180 V ac?

- ◆ **Yes:** Go to step 3.
- ◆ **No:** Inform the customer that power voltage at the input to the BPA is either missing or too low and needs to be corrected. **This ends the procedure.**

3. Use the following table to perform the appropriate action for the SRC you are working with.

| SRC      | Action                                                                       | Link to locations information                                       |
|----------|------------------------------------------------------------------------------|---------------------------------------------------------------------|
| 1xxx1D04 | Replace the cables between the front light strip and the service processors. | <a href="#">Locations model ESCALA PL 3250R and ESCALA PL 6450R</a> |

|                                              |                                                                                                                                                                                                             |                                                                                                                                                                                                                                                 |
|----------------------------------------------|-------------------------------------------------------------------------------------------------------------------------------------------------------------------------------------------------------------|-------------------------------------------------------------------------------------------------------------------------------------------------------------------------------------------------------------------------------------------------|
| 1xxx1D05                                     | Replace the cables between the rear light strip and the service processors.                                                                                                                                 | <a href="#">Model ESCALA PL 3250R and ESCALA PL 6450R cables</a>                                                                                                                                                                                |
| 1xxx8720                                     | Replace the cables between the front BPC and the service processors.<br><br>(For model 5/75, that has a BPH between the BPC and the service processor, verify that the cable is connected and functioning.) | <a href="#">Locations model 5/75 Model 5/75 cables</a> or <a href="#">Locations model ESCALA PL 3250R and ESCALA PL 6450R Model ESCALA PL 3250R and ESCALA PL 6450R cables</a> . For frame to HMC cables, see <a href="#">External cables</a> . |
| 1xxx8721                                     | Replace the cables between the rear BPC and the service processors.<br><br>(For model 5/75, that has a BPH between the BPC and the service processor, verify that the cable is connected and functioning.)  |                                                                                                                                                                                                                                                 |
| 1xxx8731<br>1xxx8732<br>1xxx8733<br>1xxx8734 | Replace the cables between both BPCs and the service processors.<br><br>(For model 5/75, that has a BPH between the BPC and the service processor, verify that the cable is connected and functioning.)     |                                                                                                                                                                                                                                                 |

Parent topic: [Symbolic FRUs](#)

---

## CACHBAT

The cache battery pack may be failing.

1. Use the cache battery pack location information in the service action log (SAL) if it is available. If the location is not available, use the address of the storage IOA (see [System reference code \(SRC\) address formats](#)) to find the location (see [Finding part locations](#)).
2. Using the type number of the storage IOA at the location you found, go to [Part number catalog](#) to determine the cache battery pack part number.

**Note:** The 571F/575B combination storage and auxiliary cache IOA card set uses two card slot locations. The battery pack is located on the 575B side of the card set, regardless of the location found in the previous steps.

3. To exchange the cache battery pack, see [Replacing the cache battery pack on type 2748, 2757, 2763, 2778, 2780, 2782, 5703, 5708, 5709, 571B, 571E, 571F, 573D, 574F, 575B cards](#).

**This ends the procedure.**

Parent topic: [Symbolic FRUs](#)

---

## Replacing the cache battery pack on type 2748, 2757, 2763, 2778, 2780, 2782, 5703, 5708, 5709, 571B, 571E, 571F, 573D, 574F, 575B cards

Use this procedure to remove or replace the cache battery pack from type 2748, 2757, 2763, 2778, 2780,

2782, 5703, 5708, 5709, 571B, 571E, 571F, 573D, 574F, 575B cards.

**Important:** Removing the cache battery with the system/partition in a powered off state may result in the loss of customer data. If the system has been powered down prior to the battery service action, you must IPL to DST and continue this procedure before replacing the battery.

The following safety notice pertains to the 2748 cache battery pack.

**CAUTION:**The battery is a nickel-cadmium battery. To avoid possible explosion, do not burn. Exchange only with the IBM-approved part. Recycle or discard the battery as instructed by local regulations. (C005a)

The following safety notice pertains to the following cache battery packs: 2763, 2778, 2782, 5703, 5709, and 573D.

**CAUTION:**The battery is a nickel metal hydride battery. To avoid possible explosion, do not burn. Exchange only with the approved part. Recycle or discard the battery as instructed by local regulations. (C006a)

The following safety notice pertains to the following cache battery packs: 2757, 2780, 5708, 571B, 571E, 571F, 574F, 575B.

**CAUTION:**The battery is a lithium ion battery. To avoid possible explosion, do not burn. Exchange only with the approved part. Recycle or discard the battery as instructed by local regulations. (C007a)

**Attention:** All cards are sensitive to electrostatic discharge. See [Working with electrostatic discharge-sensitive parts](#).

**Note:** When replacing the cache battery pack, the battery must be disconnected for at least 60 seconds before connecting the new battery. This is the minimum amount of time needed for the card to recognize that the battery has been replaced.

To remove or replace the cache battery pack:

1. Is the cache battery pack on one of the following type cards: 2757, 2780, 5708, 571B, 571E, 571F, 574F, B?
  - ◆ Yes: Go to [RAID disk controller cache battery pack](#), and select the appropriate procedure.
  - ◆ No: Continue with the next step.



2. To replace a cache battery pack and prevent possible data loss, force the cache battery pack into an error state before replacing it. This will ensure all cache data is written to disk before battery replacement. To force the cache battery pack into an error state, perform the following:
  - a. Select System Service Tools (SST). If you cannot get to SST, select DST. Do not perform a system IPL to get to DST.
  - b. Select Start a Service Tool > Hardware Service Manager.
  - c. Select Work with resources containing cache battery packs > Force battery pack into error state for the I/O card you are working with.
  - d. On the Force Battery Packs Into Error State screen, verify the correct I/O adapter has been selected and choose the function key to confirm your choice.
  - e. Continue with the next step.
3. Is the cache battery pack on a type 5709 or 573D card?
  - ◆ No: Continue with the next step.
  - ◆ Yes: Remove the RAID enablement card using one of the following procedures, then go to step 5:
    - ◇ For model 5/20: [Remove the model ESCALA PL 250T/R RAID enablement card](#)
    - ◇ For model 5/70: [Exchanging the RAID enablement card in the model ESCALA PL 1650R-L+ and ESCALA PL 850R/PL 1650R/R+](#)
4. Remove the card using the concurrent card removal and replacement procedure for the model or expansion unit that you are working on (see [Removing and replacing parts](#)). Then continue with the next step.

**Note:** If the concurrent card removal and replacement procedure fails, then power the system down normally prior to replacing the cache battery pack (see [Powering on and powering off](#)).

5. Locate the casing A that holds the battery pack (see [Figure 1](#), [Figure 2](#), or [Figure 3](#) below).
6. Squeeze the casing A to remove battery unit from the card.
7. Remove the plug that connects the battery unit and the card.

**Note:** The plug fits in the board only one way so it cannot be inserted incorrectly during the replacement phase.

8. Remove the battery unit from the battery casing. Save the battery casing, because the replacement battery pack is not equipped with a casing.

**Note:** Ensure that the cache battery pack is disconnected for at least 60 seconds before connecting the new battery. This is the minimum amount of time needed for the card to recognize that the battery has been replaced.

9. Install the new cache battery pack by reversing this procedure. If necessary, refer to the replace the card using the concurrent card removal and replacement procedure for the model or expansion unit that you are working on (see [Removing and replacing parts](#)). This ends the procedure.

*Figure 1. Cache battery pack (A) and cache directory card (B) for type 2748, 2763, and 2778*

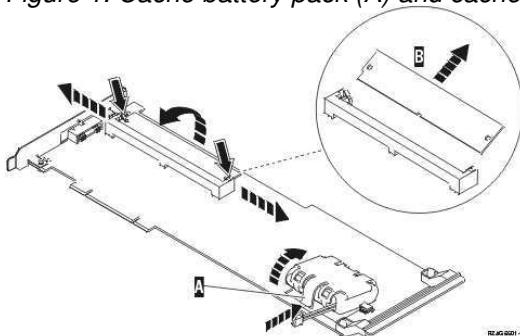


Figure 2. Cache battery pack (A) and cache directory card (B) for type 2782, 5703

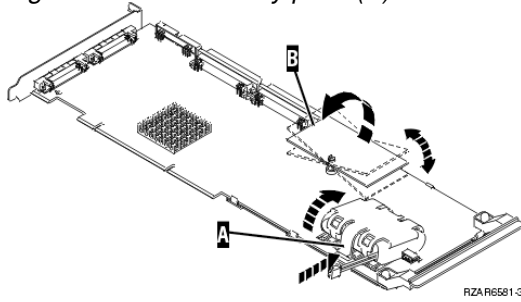
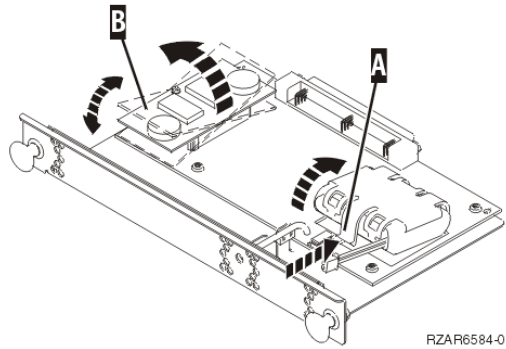


Figure 3. Cache battery pack (A) and cache directory card (B) for type 5709, 573D



**Parent topic:** [Removing and replacing parts on type 2748, 2757, 2763, 2778, 2780, 2782, 4758, 4764, 5703, 5708, 5709, 571B, 571E, 571F, 573D, 574F, 575B](#)

## CACHE

This symbolic FRU is no longer supported.

**Parent topic:** [Symbolic FRUs](#)

## CAPACTY

The failing component is the VPD card.

After the part has been replaced and before powering on the system, make sure the system vital product data is restored (see [Programming vital product data](#)); otherwise, the system will fail to IPL.

Use this table to identify and replace the VPD card.

| System model                              | Name of symbolic FRU to locate | FRU name | Link to locations information                                           |
|-------------------------------------------|--------------------------------|----------|-------------------------------------------------------------------------|
| ESCALA PL 250R-VL or<br>ESCALA PL 450R-XS | CAPACTY                        | VPD Card | <a href="#">Locations</a> <a href="#">model</a><br>ESCALA PL 250R-VL or |

|                                                   |         |                                                              |                                                                                                   |
|---------------------------------------------------|---------|--------------------------------------------------------------|---------------------------------------------------------------------------------------------------|
|                                                   |         |                                                              | <a href="#">ESCALA PL 450R-XS</a>                                                                 |
| ESCALA PL 250R-L, PL 250R-L+ or PL 450R-VL+       | CAPACTY | VPD card                                                     | <a href="#">Locations</a> <a href="#">model ESCALA PL 250R-L</a>                                  |
| ESCALA PL 250T/R, PL 250T/R+ or PL 450T/R-L+ and  | CAPACTY | VPD card                                                     | <a href="#">Locations</a> <a href="#">Model ESCALA PL 250T/R and</a>                              |
| ESCALA PL 450T/R, PL 450T/R+ or PL 850T/R-L+      | CAPACTY | VPD card                                                     | <a href="#">Locations</a> <a href="#">model 55x</a>                                               |
| ESCALA PL 1650R-L+ and ESCALA PL 850R/PL 1650R/R+ | CAPACTY | VPD card (on the primary unit or any of the secondary units) | <a href="#">Locations</a> <a href="#">model ESCALA PL 1650R-L+ and ESCALA PL 850R/PL 1650R/R+</a> |
| 5/75                                              | CAPACTY | VPD card                                                     | <a href="#">Locations</a> <a href="#">model 5/75</a>                                              |
| ESCALA PL 3250R and ESCALA PL 6450R               | CAPACTY | VPD card                                                     | <a href="#">Locations</a> <a href="#">model ESCALA PL 3250R and ESCALA PL 6450R</a>               |

Parent topic: [Symbolic FRUs](#)

## CARDFLT

Use this information to perform the appropriate action for the SRC you are working with.

| Model                               | SRC                             | Replace this FRU                                                                         | Link to locations information                                                       |
|-------------------------------------|---------------------------------|------------------------------------------------------------------------------------------|-------------------------------------------------------------------------------------|
| ESCALA PL 3250R and ESCALA PL 6450R | 1xxx1D00                        | Service processor 0                                                                      | <a href="#">Locations</a> <a href="#">model ESCALA PL 3250R and ESCALA PL 6450R</a> |
|                                     | 1xxx1D01                        | Service processor 1                                                                      |                                                                                     |
|                                     | 1xxx1D04 or 1xxx1D05            | Try replacing each service processor, one at a time, until the problem is resolved.      |                                                                                     |
|                                     | 1xxx1D02                        | Oscillator 0                                                                             |                                                                                     |
|                                     | 1xxx1D03                        | Oscillator 1                                                                             |                                                                                     |
|                                     | 1xxx1D10                        | Multiplexer card                                                                         |                                                                                     |
|                                     | 1xxx1D11 through 1xxx1D18       | Bus adapter <b>x</b> , where <b>x</b> is the final digit in the SRC (1xxx 1D1 <b>x</b> ) |                                                                                     |
| 5/75                                | 1xxx1D00, 1xxx1D11, or 1xxx1D12 | System backplane                                                                         | <a href="#">Locations</a> <a href="#">model 5/75</a>                                |

Parent topic: [Symbolic FRUs](#)

## CARDTMP

The cryptographic adapter has detected a voltage and/or temperature change in its physical operating environment.

Correct the voltage and/or temperature condition. Vary off the cryptographic device description associated with the device resource on the adapter resource and vary it back on.

Parent topic: [Symbolic FRUs](#)

## CBLALL

A power cable may be the failing item.

When there is a location and part number displayed on the control panel of a system or expansion tower, replace that FRU first.

Perform the following to determine the part number of the failing part.

1. Is the reference code 1xxx 1502, 1512, 1522, or 1532?

- ◆ **No:** Continue with the next step.

- ◆ **Yes:** Exchange the following one at a time (see [Finding part locations](#)):

For 50/88, 05/88:

- ◆ SPCN cable PWRC03
- ◆ SPCN cable PWRC02
- ◆ Power distribution card

For 11D/10, 11D/11, 11D/20, and 57/90:

- ◆ SPCN cable
- ◆ I/O unit backplane

For all other units:

- ◆ SPCN cable
- ◆ Power distribution card

**This ends the procedure.**

2. Is the reference code 1xxx 4410, 4411, 4412, 4413, 4414, 4415, or 4417?

- ◆ **No:** Continue with the next step.

- ◆ **Yes:** Exchange the following one at a time (see [Finding part locations](#)):

- ◆ Cable from charger A01 to batteries T01 T04
- ◆ Cable from charger to power supply 1, 2, or 3

**This ends the procedure.**

3. Is the reference code 1xxx 2612, 9012, 9013, 90F0, 90F2, 9135, 9231, 9232, 9233, 9235, 9236, 9280, 9281, 9282, or C62E?

- ◆ **No:** Continue with the next step.

- ◆ **Yes:** The failing item is the SPCN frame-to-frame cable or adapter. The following list shows the possible failing items, and the cable or adapter lengths when appropriate (see [Part number catalog](#)):

- ◆ 6.0 meters
- ◆ 15.0 meters
- ◆ 30.0 meters
- ◆ 60.0 meters
- ◆ SPCN optical cable (100.0 meters)
- ◆ SPCN optical adapter
- ◆ SPCN port cable (frame-to-node)
- ◆ Integrated xSeries server SPCN-Y cable assembly

**This ends the procedure.**

4. Is the reference code 1xxx 2613?

- ◆ **No:** Continue with the next step.

- ◆ **Yes:** This configuration requires 200 V ac (or -48V dc if your system is specially configured to operate with this voltage). If the system has 2 power supplies, both power supplies must be at the same line voltage. Go to [Determine line cord, plug, and receptacle type](#) in the Planning topic to determine the power cable part number for systems in your country or region. **This ends the procedure.**

5. Is the reference code 1xxx 8940, 8941, 8942, or 8943?

- ◆ **Yes:** Continue with the next step.

- ◆ **No:** Go to step 8.

6. Reseat the RS 485 cable.

**Note:** It may take up to one minute for the frame ID to stop blinking.

Does this correct the problem?

- ◆ **Yes: This ends the procedure.**
  - ◆ **No:** Continue with the next step.
7. Exchange the RS 485 cable assembly (see [Part number catalog](#)).

**Note:** It may take up to one minute for the frame ID to stop blinking.

Does this correct the problem?

- ◆ **Yes: This ends the procedure.**
  - ◆ **No:** Call your service provider. **This ends the procedure.**
8. Is the reference code 1xxx9133?
- ◆ **No:** Go to step 11.
  - ◆ **Yes:** Continue with the next step.
9. Verify that the expansion units are cabled correctly with both RIO cables and power network connections (see [Finding part locations](#)) and that they are powered on and not indicating an error condition. Resolve any problems you discover. Does the SRC persist?
- ◆ **No: This ends the procedure.**
  - ◆ **Yes:** Continue with the next step.
10. There may be a problem in the power network connection. Check the error log for another 1xxxxxxx SRC that surfaced around the same time as the 1xxx9133 SRC. Is such an SRC present?
- ◆ **No:** Contact your next level of support. **This ends the procedure.**
  - ◆ **Yes:** Return to the [Start of call procedure](#) and service the 1xxxxxxx SRC to resolve this problem. **This ends the procedure.**
11. Is the reference code 1xxx9137 or 1xxx9138?
- ◆ **No:** Return to the [Start of call procedure](#). **This ends the procedure.**
  - ◆ **Yes:** Continue with the next step.

**Note:** If you are performing maintenance on your system and as a result are now experiencing a 1xxx9137 or 1xxx9138 reference code, ensure your maintenance actions did not cause the reference codes before replacing any additional parts. Ignore the 1xxx9137 or 1xxx9138 reference codes if you are doing concurrent maintenance on the affected tower or RIO/HSL associated with the affected tower, cable, or adapter.

12. Verify the following:
- ◆ RIO cables are connected and seated correctly.
  - ◆ If you are servicing an ESCALA PL 850R/PL 1650R/R+, ensure the flex cables if present, are connected and seated properly. Note that the flex cables are located on the front and back of the system.
  - ◆ All connected expansion units are powered on and not indicating an error condition.

**Note:** If a problem is found during any of these checks, resolve that problem. If your system is still producing an SRC, continue with the next step.

13. If your system produced SRC 1xxx9137, check the error log for SRC B700698x that surfaced around the same time as SRC 1xxx9137. Did your system produce SRC B700698x?
- ◆ **No:** Contact your next level of support. **This ends the procedure.**
  - ◆ **Yes:** Return to the [Start of call procedure](#) and resolve SRC B700698x to solve the problem. **This ends the procedure.**

**Note:** If your system produced SRC 1xxx9138, you have a faulty location code or vital product data. Contact your next level of support. **This ends the procedure.**

Parent topic: [Symbolic FRUs](#)

---

## CBLCONT

This symbolic FRU is used to show additional locations for the endpoints of cables.

This FRU appears in the serviceable event user interface of an operating system, service processor, or the HMC, and is associated with the cable FRU that precedes it in the list. The location code associated with this FRU is the location of another end of the same cable. Cable FRUs are shown in the display by listing the cable's part number or symbolic FRU first with the location code of one end of the cable. Each additional cable endpoint is represented as a "CBLCONT" FRU with a location code for another endpoint.

**Note:** If question marks (???) appear at the end of the location code, then the port could not be determined. Use the location code associated with the other end of the cable. If question marks appear for both port locations, use the isolation procedures suggested in the Description/Action column of the reference code table for this SRC.

Parent topic: [Symbolic FRUs](#)

---

## CDAWKLD

Too many communications lines are in use.

Parent topic: [Symbolic FRUs](#)

---

## CDTRAY

This symbolic FRU is not supported.

Parent topic: [Symbolic FRUs](#)

---

## CHECK

Look here for information about the CHECK symbolic FRU.

If the attached device is an external device, do the following before exchanging any parts:

1. Ensure that the device is powered on.
2. Is there a SCSI interface between the IOP/IOA and the device?
  - ◆ **No:** Continue with the next step.
  - ◆ **Yes:** Perform the following:
    - ◇ If an interposer is required, make sure that it is connected between the I/O processor and the SCSI cable.
    - ◇ Ensure that the SCSI cable is seated correctly, and that there are no bent or damaged pins on the SCSI cable.
    - ◇ Ensure that a terminating plug is attached to the device end of the SCSI cable.
    - ◇ Continue with the next step.

3. Is there a Fibre Channel interface between the IOP/IOA and the device?
  - ◆ **No:** Continue with the next step.
  - ◆ **Yes:** Perform the following:
    - ◇ Verify that any hub or gateway devices are powered on.
    - ◇ Verify that the Fibre Channel cable is correctly connected to the ports.
    - ◇ If a cleaning kit is available, clean the Fibre Channel cable connectors.
    - ◇ Continue with the next step.
4. Perform the [Verification procedures](#) to see if the problem was corrected.

**This ends the procedure.**

Parent topic: [Symbolic FRUs](#)

---

## CLCKMOD

The logic oscillator is failing.

Use the table below to determine which FRU to replace and how to replace it.

| System model                           | Name of symbolic FRU to locate | FRU name                                                      | Link to locations information                                                          |
|----------------------------------------|--------------------------------|---------------------------------------------------------------|----------------------------------------------------------------------------------------|
| ESCALA PL 250R-VL or ESCALA PL 450R-XS | CLCKMOD                        | System backplane                                              | <a href="#">Locations</a> <a href="#">model ESCALA PL 250R-VL or ESCALA PL 450R-XS</a> |
| ESCALA PL 250R-L                       | CLCKMOD                        | System backplane                                              | <a href="#">Locations</a> <a href="#">model ESCALA PL 250R-L</a>                       |
| ESCALA PL 250T/R                       | CLCKMOD                        | System backplane                                              | <a href="#">Locations</a> <a href="#">Model ESCALA PL 250T/R</a>                       |
| ESCALA PL 450T/R                       | CLCKMOD                        | System backplane                                              | <a href="#">Locations</a> <a href="#">Model ESCALA PL 450T/R</a>                       |
| ESCALA PL 850R/PL 1650R/R+             | CLCKMOD                        | I/O backplane (on primary unit or one of the secondary units) | <a href="#">Locations</a> <a href="#">Model ESCALA PL 850R/PL 1650R/R+</a>             |
| 5/75                                   | CLCKMOD                        | System backplane                                              | <a href="#">Locations</a> <a href="#">model 5/75</a>                                   |
| ESCALA PL 3250R and ESCALA PL 6450R    | CLCKMOD                        | Oscillator 1Oscillator 2                                      | <a href="#">Locations</a> <a href="#">model ESCALA PL 3250R and ESCALA PL 6450R</a>    |

**This ends the procedure.**

Parent topic: [Symbolic FRUs](#)

---

## CLRNVRM

A problem may exist with the service processor NVRAM.

Perform the following:

1. Is your system managed by the Hardware Management Console (HMC)?
  - ◆ **No:** Continue with the next step.
  - ◆ **Yes:** Continue with step 3.
2. Perform the following:
  - a. Power off the system.
  - b. Using ASMI, select System Service Aids > Factory Configuration.
  - c. Select Continue to clear the configuration.

**Note:** Clearing the configuration causes the loss of all the configured system settings (such as the HMC access and ASMI passwords, time of day, network configuration, hardware deconfiguration policies, and so on) that you might have set by using the user interfaces. Also, partition-related information and platform error logs are lost, and the service processor is reset. Before continuing with this operation, make sure that you manually record all settings that you need to preserve.

Make sure that the interface HMC1 or HMC2 not being used by ASMI is disconnected from the network. Follow the instructions in the system service publications to configure the network interfaces after the reset.

**This ends the procedure.**

3. Your system is managed by the HMC. Is your system a model ESCALA PL 3250R or 5/95?
  - ◆ **Yes:** Use [TOD\\_BAT](#) to locate and remove the time of day battery.
  - ◆ **No:** Do not replace the battery! Instead, clear the NVRAM by removing the battery for five minutes and then reinstalling it.

**Note:** Clearing the configuration causes the loss of all the configured system settings (such as the HMC access and ASMI passwords, time of day, network configuration, hardware deconfiguration policies, and so on) that you might have set by using the user interfaces. Also, partition-related information and platform error logs are lost, and the service processor is reset. Before continuing with this operation, make sure that you manually record all settings that you need to preserve.

Make sure that the interface HMC1 or HMC2 not being used by ASMI or the HMC is disconnected from the network. Follow the instructions in the system service publications to configure the network interfaces after the reset.

**This ends the procedure.**

Parent topic: [Symbolic FRUs](#)

---

## CMPRES1

The compressed device and the compression IOA are not compatible.

Parent topic: [Symbolic FRUs](#)

---

## CRYPBAT

The batteries for the cryptographic adapter need to be replaced.

Refer to [Part number catalog](#) for battery replacement kit part number information. Then go to [Replacing the battery on a type 4758 card](#) or [Replacing the battery on a type 4764 card](#) to replace the batteries.



**Attention:** If you remove any of the batteries without first backing up the power with a fresh battery, the data in the card's protected memory could be lost, which would render the cryptographic adapter useless and require its replacement. Because the 4758-023 adapter contains 4 batteries, and the battery replacement kit contains only 2 batteries, *do not* attempt to remove or replace batteries unless you have two battery replacement kits. All other cryptographic adapters contain only 2 batteries, and therefore require only one battery replacement kit.

Parent topic: [Symbolic FRUs](#)

---

## Replacing the battery on a type 4758 card

Use this procedure to remove or replace the PCI cryptographic coprocessor card batteries in type 4758.

**Note:** Two battery replacement kits (see [Part number catalog](#)) are required to replace the batteries in the 4758-023 card, since the card contains four batteries, and each battery replacement kit contains two new batteries. Other 4758 cryptographic adapter cards contain only two batteries, and therefore require only one battery replacement kit.

**CAUTION:** Only trained service personnel may replace this battery. The battery contains lithium. To avoid possible explosion, do not burn or charge the battery.

*Do Not:*

- \_\_\_ Throw or immerse into water
- \_\_\_ Heat to more than 100 degrees C (212 degrees F)
- \_\_\_ Repair or disassemble

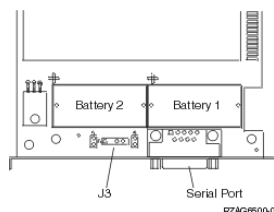
Exchange only with the approved part. Recycle or discard the battery as instructed by local regulations. (C002a)

**Attention:** Any loss of battery power erases data stored in the card's protected memory and renders the card useless.

To remove or replace the PCI Cryptographic coprocessor card's batteries:

1. Remove the cryptographic coprocessor card using the concurrent remove and replace procedure for cards on the system or expansion unit in which the card is located (see [Removing and replacing parts](#)).
2. Locate the lithium batteries, which are located in adjacent holders, with the battery 2 holder above the J3 connector. Refer to the following illustration.

*Figure 1. Battery Locations on the 4758 PCI Cryptographic Coprocessor*



**Note:** The 4758-023 card contains four batteries, even though only two batteries are shown in the previous figure. Battery 3 is directly above battery 1, and battery 4 is directly above battery 2.

3. Is the card you are working on a 4758-023 card?
  - ◆ Yes: The card has four batteries. Go to step 11.
  - ◆ No: The card has two batteries. Continue with the next step.
4. Open the battery replacement kit. Insert one of the new batteries into the battery tray provided with the kit. The '+' on the battery must be oriented in the battery tray with the same polarity matching the '+' on the tray.
5. Connect the battery tray's cable to the J3 connector on the card. This maintains battery power to the card while the new batteries are installed.
6. Replace the battery in the battery 1 position with a new battery. The '+' on the battery must be oriented in the holder with the same polarity matching the '+' on the holder.
7. Replace the battery in the battery 2 position with the battery in the battery tray. The '+' on the battery must be oriented in the holder with the same polarity matching the '+' on the holder.
8. Remove the battery tray from the J3 connector and discard it.
9. Place the new battery warning label (part number 04K9421) over the two new batteries in battery positions 1 and 2.
10. Reinstall the card. This ends the procedure.
11. The card is a 4758-023 card. Open both of the battery replacement kits. Insert one of the new batteries into the battery tray provided with the kit. The '+' on the battery must be oriented in the holder with the same polarity matching the '+' on the holder.
12. Connect the battery tray's cable to the J3 connector on the 4758 card. This maintains battery power to the card while the new batteries are installed.
13. Remove and discard the two battery warning labels which cover both sets of batteries.
14. Replace the battery in the battery 1, 2, and 3 positions with a new battery. The '+' on the battery must be oriented in the holder with the same polarity matching the '+' on the holder.
15. Replace the battery in the battery 4 position with the battery in the battery tray. The '+' on the battery must be oriented in the holder with the same polarity matching the '+' on the holder.
16. Remove the battery tray from the J3 connector and discard it.
17. Place one of the new battery warning labels (PN 04K9421) over the two new batteries in battery positions 1 and 2. Place the other new battery warning label over the two new batteries in battery positions 3 and 4.
18. Reinstall the card. This ends the procedure.

**Parent topic:** [Removing and replacing parts on type 2748, 2757, 2763, 2778, 2780, 2782, 4758, 4764, 5703, 5708, 5709, 571B, 571E, 571F, 573D, 574F, 575B](#)

## Replacing the battery on a type 4764 card

Use this procedure to remove or replace the type 4764 PCI cryptographic coprocessor card batteries.

Two lithium batteries mounted on the card supply power to the card's components, including protected memory. Your support software or application software can query the card to determine whether the batteries need to be replaced.

When shipped from the factory, the protected memory contains a certified device key. If your coprocessor has been initialized by support software, the protected memory contains secret data, including a master cryptographic key, user profiles, and user passwords.

**Attention:** If you remove either of the batteries without first backing up the power with a fresh battery, the data in protected memory can be lost. The Replacement Battery Kit (part 41V1061) provides the battery tray needed to provide backup power while you replace the batteries.

**CAUTION: Only trained service personnel may replace this battery. The battery contains lithium. To avoid possible explosion, do not burn or charge the battery.**

*Do Not:*

- \_\_\_ Throw or immerse into water
- \_\_\_ Heat to more than 100 degrees C (212 degrees F)
- \_\_\_ Repair or disassemble

Exchange only with the approved part. Recycle or discard the battery as instructed by local regulations. (C002a)

The Replacement Battery Kit should include:

- Two replacement batteries
- A battery tray with connecting wires
- Two sets of spare battery attention labels

To replace the batteries, follow these steps:

1. Turn off the computer and all attached devices.
2. Disconnect all cables, including the power cable.

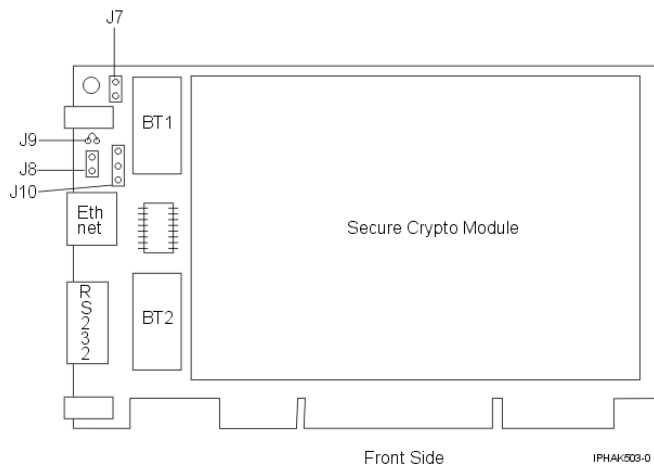
**CAUTION: The battery is a nickel-cadmium battery. To avoid possible explosion, do not burn. Exchange only with the IBM-approved part. Recycle or discard the battery as instructed by local regulations. (C005a)**

3. Remove the cover from the expansion slots according to the directions provided with your computer.
4. Open the Battery Replacement Kit.

**Attention:** Electrostatic discharge (ESD) can damage the card and its components. Wear an ESD wrist strip while handling and installing the card, or take the following precautions:

- ◆ Limit your movements, this helps prevent static electricity building up around you.
  - ◆ Prevent others from touching the card or other components.
  - ◆ Handle the card by its edges only. Do not touch exposed circuitry and components.
5. Remove the card from the bus slot in the host computer.
  6. Insert one of the new batteries into the battery tray provided with the kit. Align the + on the battery with the + on the battery tray (the end with the red wire). Connect the tray wires to the J10 connector located near the RS-232 serial port, as shown below. The connector is polarized to ensure a proper connection.

*Figure 1. Battery locations on the PCI cryptographic coprocessor*



**Attention:** Any loss of power erases data stored in the card's protected memory. To prevent loss, ensure that the battery tray contains a fresh battery and is attached to the J10 connector.

7. Remove the battery attention labels from the battery holders on the card. These labels can be torn off and discarded. They are to be replaced by the spare labels included in the kit.
8. Remove the battery from the BT1 position. To eject the battery, turn the coprocessor over and insert a small object, such as a screwdriver, through the hole to eject the battery.
9. Replace the battery in the BT1 position with a new battery.
10. Replace the battery in the BT2 position with the battery in the battery tray. The new battery already installed in the BT1 position provides power to the adapter while you perform this step.
11. Remove the battery holder from the J10 connector.
12. Reapply the spare battery attention labels onto the holders on the card covering the batteries.
13. Reinstall the coprocessor into the PCI-X bus slot, and be sure the card is fully seated.
14. Replace the host computer's cover.
15. Reconnect the power cable and any other cables you disconnected.
16. Power on the computer. The card runs its power on self-test (POST).
17. Reinstall the adapter.

**This ends the procedure.**

**Parent topic:** [Removing and replacing parts on type 2748, 2757, 2763, 2778, 2780, 2782, 4758, 4764, 5703, 5708, 5709, 571B, 571E, 571F, 573D, 574F, 575B](#)

## CTLPNCD

This symbolic FRU is not supported on the system. Continue with the next FRU in the failing item list.

**Parent topic:** [Symbolic FRUs](#)

## DASDBP

Use this procedure when determining what DASD backplane to replace on ESCALA PL 250T/R, ESCALA PL 450T/R, or an ESCALA PL 850R/PL 1650R/R+

The failing component is a direct access storage device (DASD) backplane. Use the following table to determine what FRU to replace and how to replace it.

| System model                                 | Name of symbolic FRU to locate | FRU name (Replace FRUs one at a time, in the order listed, from top to bottom.) | Link to locations information                                                                  |
|----------------------------------------------|--------------------------------|---------------------------------------------------------------------------------|------------------------------------------------------------------------------------------------|
| ESCALA PL 250T/R                             | DASDBP                         | Disk drive (1 - 4) backplane<br>Disk drive (5 - 8) backplane                    | <a href="#">Locations model ESCALA PL 250T/R, PL 250T/R+ or PL 450T/R-L+ and 285</a>           |
| ESCALA PL 450T/R                             | DASDBP                         | Disk drive (1 - 4) backplane<br>Disk drive (5 - 8) backplane                    | <a href="#">Locations model ESCALA PL 450T/R, PL 450T/R+ or PL 850T/R-L+ and OpenPower 720</a> |
| ESCALA PL 850R/PL 1650R/R+                   | DASDBP                         | Disk drive backplane                                                            | <a href="#">Locations model ESCALA PL 1650R-L+ and ESCALA PL 850R/PL 1650R/R+</a>              |
| Multiple 5/70's sequentially cabled together | DASDBP                         | <b>Primary unit:</b> Disk drive backplane                                       | <a href="#">Locations model ESCALA PL 1650R-L+ and ESCALA PL 850R/PL 1650R/R+</a>              |
|                                              |                                | <b>Secondary unit 1:</b> Disk drive backplane                                   |                                                                                                |
|                                              |                                | <b>Secondary unit 2:</b> Disk drive backplane                                   |                                                                                                |
|                                              |                                | <b>Secondary unit 3:</b> Disk drive backplane                                   |                                                                                                |

Parent topic: [Symbolic FRUs](#)

## DCA

A DCA needs to be replaced.

Use the following table to determine which DCA to replace, and then follow the link to locations information to find the appropriate removal information.

Table 1. Model 575

| SRC      | FRU to replace     | Link to locations information        |
|----------|--------------------|--------------------------------------|
| 1xxx8710 | Power supply (E-1) | <a href="#">Locations model 5/75</a> |

Table 2. Models ESCALA PL 3250R and ESCALA PL 6450R

| SRC      | FRU to replace   | Link to locations information                                       |
|----------|------------------|---------------------------------------------------------------------|
| 1xxx8710 | DCA 01 on Node 0 | <a href="#">Locations model ESCALA PL 3250R and ESCALA PL 6450R</a> |
| 1xxx8711 | DCA 02 on Node 0 | <a href="#">Locations model ESCALA PL 3250R and ESCALA PL 6450R</a> |

If the problem persists, check cable routing and connections. For more information, see [Model 5/75 cables](#) or [Model ESCALA PL 3250R and ESCALA PL 6450R cables](#).

Parent topic: [Symbolic FRUs](#)

## DEVBPLN

A device backplane may be failing.

Does the SRC that sent you here begin with 506x?

- **No:** Replace the device backplane, using the device backplane information in the Service Action Log. See [Finding part locations](#) for location, part number, and removal and replacement procedure information.
- **Yes:** Replace the SCSI interface card of the 5786 or 5787 Disk Expansion Unit. Go to [Locations 57/86, 57/87, D24, and T24 expansion unit](#) to exchange the failing item. If this does not fix the problem, continue replacing the other failing items in the failing item list. If the other failing items do not fix the problem, replace the disk expansion unit chassis.

Parent topic: [Symbolic FRUs](#)

---

## DEVICE

The addressed storage device is the failing item.

Perform the following.

1. Is the device location information available in the Service Action Log (SAL)?
  - ◆ **No:** Continue with the next step.
  - ◆ **Yes:** Exchange the failing item (see [Starting disk service](#)).
2. Find the IOP address and the device address (see [System reference code \(SRC\) address formats](#)).
3. To determine the location of the I/O processor card, see [Finding part locations](#) and find the diagram of the system unit or the expansion unit. Then, find:
  - ◆ The IOP card location identified by the direct select address.
  - ◆ The addressed storage device location identified by the device address.
4. Exchange the failing device. Use the device type to determine the part.

**This ends the procedure.**

Parent topic: [Symbolic FRUs](#)

---

## DEVTERM

The device terminating plug may be failing.

Perform the following.

1. Find the IOA type:
  - a. Find the IOA location information in the Service Action Log if it is available. If the location is not available, find the address of the IOA (see [System reference code \(SRC\) address formats](#)). Use the address to find the location (see [Finding part locations](#)).
  - b. Find the IOA card in the system and read the type number of the card at that location.

2. Use the information in the following list to determine the failing terminating plug:
3. Exchange the failing item.

**Note:** If the terminating plug is located on a backplane, go to symbolic FRU [BACKPLN](#). Follow the procedure until the terminating plug is accessible and then remove or exchange the plug.

**This ends the procedure.**

Parent topic: [Symbolic FRUs](#)

## DIMM 0

Use this topic to view the locations of DIMM 0, DIMM 1, DIMM 2, and DIMM 3 on the 2890 and 2892 Integrated xSeries Server (IXS) cards.

In the following two figures, the first DIMM from the top of the IXS card (DIMM 0) is the failing item. To determine the part number, go to symbolic FRU [MEMORY](#). **This ends the procedure.**

Figure 1. Locations of DIMM 0, DIMM 1, DIMM 2, and DIMM 3 on 2890 Integrated xSeries Server (IXS) card.

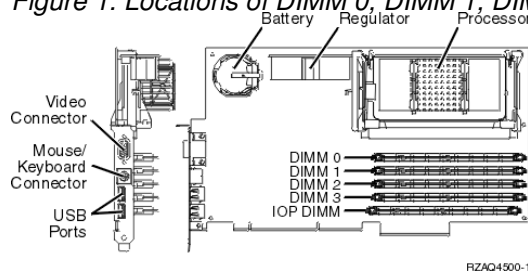
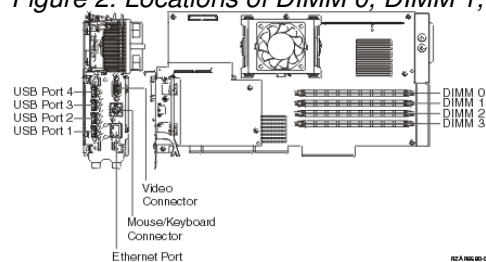


Figure 2. Locations of DIMM 0, DIMM 1, DIMM 2, and DIMM 3 on 2892 Integrated xSeries Server (IXS) card.



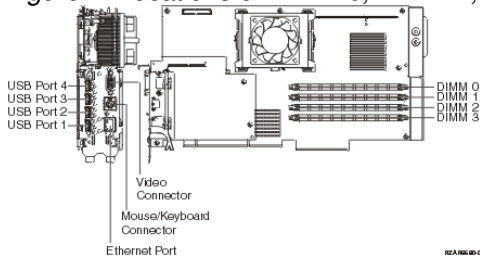
Parent topic: [Symbolic FRUs](#)

## DIMM0\_1

Use this topic to view the locations of DIMM 0, DIMM 1, DIMM 2, and DIMM 3 on 2892 Integrated xSeries Server (IXS) card.

The first or second DIMM from the top (DIMM 0 or DIMM 1) of the IXS card is the failing item. To determine the part number, go to symbolic FRU [MEMORY](#). **This ends the procedure.**

Figure 1. Locations of DIMM 0, DIMM 1, DIMM 2, and DIMM 3 on 2892 Integrated xSeries Server (IXS) card.



Parent topic: [Symbolic FRUs](#)

## DIMM 1

Use this topic to view the locations of DIMM 0, DIMM 1, DIMM 2, and DIMM 3 on the 2890 and 2892 Integrated xSeries Server (IXS) cards.

In the following two figures, the second DIMM from the top of the IXS card (DIMM 1) is the failing item. To determine the part number, go to symbolic FRU [MEMORY](#). **This ends the procedure.**

Figure 1. Locations of DIMM 0, DIMM 1, DIMM 2, and DIMM 3 on 2890 Integrated xSeries Server (IXS) card.

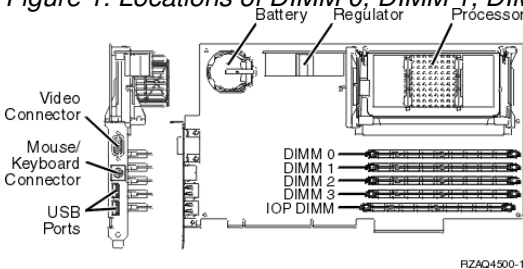
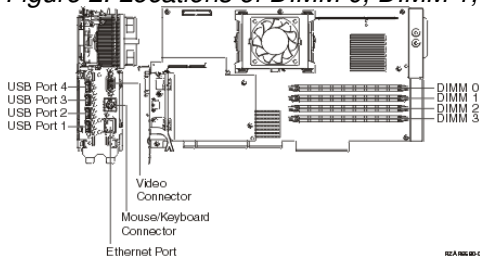


Figure 2. Locations of DIMM 0, DIMM 1, DIMM 2, and DIMM 3 on 2892 Integrated xSeries Server (IXS) card.



Parent topic: [Symbolic FRUs](#)

## DIMM 2

Use this topic to view the locations of DIMM 0, DIMM 1, DIMM 2 and DIMM 3 on the 2890 and 2892 Integrated xSeries Server (IXS) card.

In the following two figures, the third DIMM from the top (DIMM 2) of the IXS card is the failing item. To determine the part number, go to symbolic FRU [MEMORY](#). **This ends the procedure.**

Figure 1. Locations of DIMM 0, DIMM 1, DIMM 2, and DIMM 3 on 2890 Integrated xSeries Server (IXS) card.



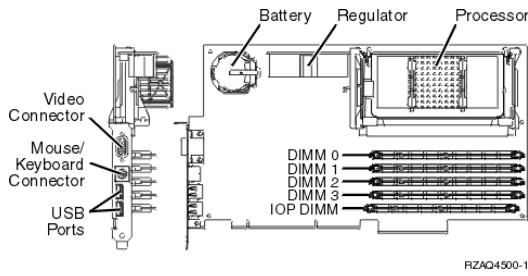
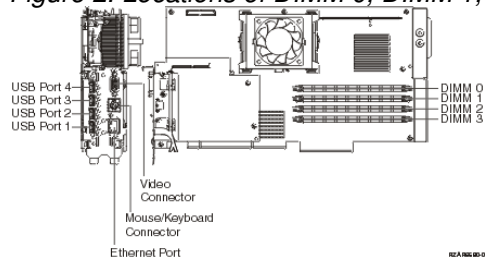


Figure 2. Locations of DIMM 0, DIMM 1, DIMM 2, and DIMM 3 on 2892 Integrated xSeries Server (IXS) card.



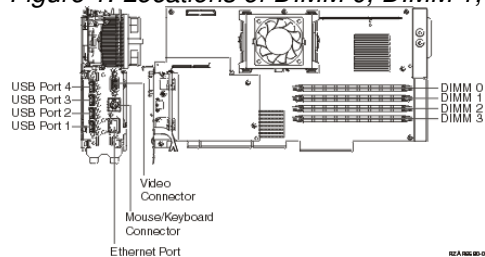
Parent topic: [Symbolic FRUs](#)

## DIMM2\_3

Use this topic to view the locations of DIMM 0, DIMM 1, DIMM 2 and DIMM 3 on 2892 Integrated xSeries Server (IXS) card.

The third or fourth DIMM from the top (DIMM 0 or DIMM 1) of the IXS card is the failing item. To determine the part number, go to symbolic FRU [MEMORY](#). **This ends the procedure.**

Figure 1. Locations of DIMM 0, DIMM 1, DIMM 2 and DIMM 3 on 2892 Integrated xSeries Server (IXS) card.



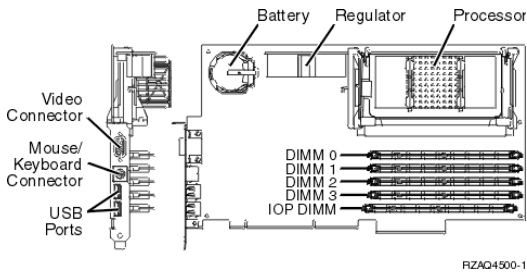
Parent topic: [Symbolic FRUs](#)

## DIMM 3

Use this topic to view the locations of DIMM 0, DIMM 1, DIMM 2 and DIMM 3 on the 2890 and 2892 Integrated xSeries Server (IXS) cards.

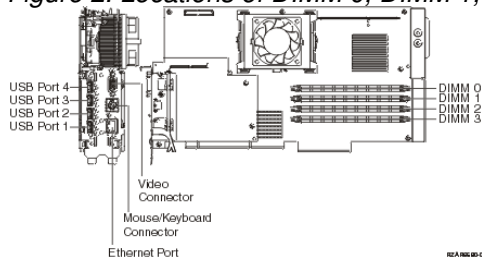
In the following two figures, the **fourth** DIMM from the top (DIMM 3) of the IXS card is the failing item. To determine the part number, go to symbolic FRU [MEMORY](#).

Figure 1. Locations of DIMM 0, DIMM 1, DIMM 2 and DIMM 3 on 2890 Integrated xSeries Server (IXS) card



RZAO4500-1

Figure 2. Locations of DIMM 0, DIMM 1, DIMM 2 and DIMM 3 on 2892 Integrated xSeries Server (IXS) card



RZAO4500-1

Parent topic: [Symbolic FRUs](#)

## DISKDRV

The disk drive and logic card may be failing.

1. Is the device location information available in the Service Action Log?
  - ◆ **No:** Continue with the next step.
  - ◆ **Yes:** To exchange the failing item, see [Disk unit recovery procedures](#). **This ends the procedure.**
2. Find the IOP address and the device address. See [System reference code \(SRC\) address formats](#).
3. See [Finding part locations](#) and find the diagram of the system unit or expansion unit and find:
  - ◆ The IOP card location that is identified by the direct select address.
  - ◆ The addressed disk location that is identified by the device address.
4. Is the SRC reported on the control panel?
  - ◆ **No:** Continue with the next step.
  - ◆ **Yes:** See [Hardware SRC formats](#). The two rightmost characters of word 2 define the SRC format. Use the correct SRC format to locate the function that contains the characters *ttt lmmm*, where:
    - ◇ *ttt* = Type number
    - ◇ *l* = Level
    - ◇ *mmm* = Model
 Then go to step 6.
5. Remove the disk unit to determine the part number. To exchange the disk drive and logic card, see [Disk unit recovery procedures](#). **This ends the procedure.**
6. Using the type information, go to [Part number catalog](#) to determine the part number. If you do not know the type, remove the disk unit to determine the part number. To exchange the disk drive and logic card, see [Disk unit recovery procedures](#).

**This ends the procedure.**

Parent topic: [Symbolic FRUs](#)

## DISKFAN

A fan in a 57/86 or 57/87 expansion unit might be failing.

Perform the following:

1. Is the fan location available in the Service Action Log?
  - ◆ **Yes:** Replace the fan at the location provided in the Service Action Log. Go to [Locations 57/86, 57/87, D24, and T24 expansion unit](#) to exchange the failing item. **This ends the procedure.**
  - ◆ **No:** Continue with the next step.
2. Is the SRC that sent you here is 506x7611 or 506x7614?
  - ◆ **Yes:** Replace the fan located in Un-A1. Go to [Locations 57/86, 57/87, D24, and T24 expansion unit](#) to exchange the failing item. **This ends the procedure.**
  - ◆ **No:** Continue with the next step.
3. Is the SRC that sent you here is 506x7621 or 506x7624?
  - ◆ **Yes:** Replace the fan located in Un-A2. Go to [Locations 57/86, 57/87, D24, and T24 expansion unit](#) to exchange the failing item. **This ends the procedure.**
  - ◆ **No:** Continue with the next step.
4. Is the SRC that sent you here is 506x7631 or 506x7634?
  - ◆ **Yes:** Replace the fan located in Un-A3. Go to [Locations 57/86, 57/87, D24, and T24 expansion unit](#) to exchange the failing item. **This ends the procedure.**
  - ◆ **No:** Continue with the next step.
5. Replace the fans located in Un-A1, Un-A2, and Un-A3 one at a time until the problem is resolved. Go to [Locations 57/86, 57/87, D24, and T24 expansion unit](#) to exchange the failing items. **This ends the procedure.**

Parent topic: [Symbolic FRUs](#)

---

## DISKIMG

There may be a problem with the Network Server Description (NWSD).

First, vary off and then vary back on the NWSD. If this does not correct the problem, delete and re-create the NWSD, or call your next level of support.

Parent topic: [Symbolic FRUs](#)

---

## DISKPWR

A power supply in a 57/86 or 57/87 expansion unit might be failing.

Perform the following:

1. Is the system reference code (SRC) that sent you here 506x1511 or 506x1515?
  - ◆ **Yes:** Replace the power supply located in Un-E1. Go to [Locations 57/86, 57/87, D24, and T24 expansion unit](#) to exchange the failing item. If this does not fix the problem, replace the power supply located in Un-E2. **This ends the procedure.**
  - ◆ **No:** Continue with the next step.
2. Is the SRC that sent you here is 506x1521 or 506x1525?
  - ◆ **Yes:** Replace the power supply located in Un-E2. Go to [Locations 57/86, 57/87, D24, and T24 expansion unit](#) to exchange the failing item. If this does not fix the problem, replace the power supply located in Un-E1. **This ends the procedure.**
  - ◆ **No:** Continue with the next step.
3. Replace the power supplies located in Un-E1 and Un-E2 one at a time until the problem is resolved. Go to [Locations 57/86, 57/87, D24, and T24 expansion unit](#) to exchange the failing items. **This ends the procedure.**

Parent topic: [Symbolic FRUs](#)

---

## DPAC

The two-port adapter cable (part number 21F9345) is the failing item.

Parent topic: [Symbolic FRUs](#)

---

## DRVSWCH

The address switches on an optical disk drive in the optical library need to be checked and verified.

Parent topic: [Symbolic FRUs](#)

---

## DSKTRY

This symbolic FRU is no longer supported.

Parent topic: [Symbolic FRUs](#)

---

## DSKUNIT

DSKUNIT is similar to the symbolic FRU DISKDRV.

See symbolic FRU [DISKDRV](#).

Parent topic: [Symbolic FRUs](#)

---

## EACODE

An error occurred in the error analysis licensed internal code.

Ask your next level of support for assistance.

Parent topic: [Symbolic FRUs](#)

---

## EXTREMD

An external removable media storage device may be failing.

1. Perform symbolic FRU [CHECK](#) before removing or replacing parts. Return here if no problems are revealed.
2. Use the device type and refer to the appropriate service documentation for that device. This documentation will help you determine the part numbers and replacement procedures that you are to use during this repair action.
3. If you are unable to locate the documentation for your specific device, contact your next level of support for assistance.

**This ends the procedure.**

Parent topic: [Symbolic FRUs](#)

---

## EXTSCSI

The external signal cable may be failing.

Perform the following:

1. Is more than one device attached?
  - ◆ **No:** Continue with the next step.
  - ◆ **Yes:** See the device documentation for information about setting the device address. **This ends the procedure.**
2. Is the attached device in the system unit?
  - ◆ **No:** Continue with the next step.
  - ◆ **Yes:** Use symbolic FRU [BACKPLN](#) to determine which signal cables to replace. **This ends the procedure.**
3. Find the IOA type:
  - a. Find the IOA location.
  - b. Use the location information of the IOA in the Service Action Log if it is available. If the location is not available, find the address. See [System reference code \(SRC\) address formats](#). Use the address to find the location. See [Finding part locations](#).
  - c. Find the IOA card in the system and read the type number of the card at that location.
4. Find the IOA type, the attached device, the cable length, and the cable part number in the following list.
5. Verify that the part number in the list is the same as the part number on the cable.
6. For external devices that are not found in the following list, use the device type and refer to the appropriate service documentation for that device. The service documentation for that device will help you determine the FRU part numbers and replacement procedures you are to use during this repair action. If you are unable to locate the documentation for your specific device, then contact your next level of support for assistance.

Table 1. External device and part numbers

| IOP or IOA Type | Device                                  | Lengths     | Part Number                                                             |
|-----------------|-----------------------------------------|-------------|-------------------------------------------------------------------------|
| 2749            | 3490, 3490/Exx, 3590                    | 2.8 meters  | 05H4647                                                                 |
| 2749            | 3490, 3490/Exx, 3590                    | 4.5 meters  | 05H4648                                                                 |
| 2749            | 3490, 3490/Exx, 3590                    | 12.0 meters | 05H4649                                                                 |
| 2749            | 3490, 3490/Exx, 3590                    | 18.0 meters | 05H4650                                                                 |
| 2749            | 3490, 3490/Exx, 3590                    | 25.0 meters | 05H4651                                                                 |
| 2749            | 3490/Fxx, 3570, 358x,<br>9427, 7208/342 | 0.5 meters  | 49G6456<br><br><b>Note:</b> For 9427 see the note following this table. |
| 2749            | 3490/Fxx, 3570, 358x,<br>9427, 7208/342 | 4.5 meters  | 49G6457<br><br><b>Note:</b> For 9427 see the note below this table.     |
| 2749            | 3490/Fxx, 3570, 358x,<br>9427, 7208/342 | 12.0 meters | 49G6458                                                                 |

Service provider information

|                        |                                                        |             |                                                                     |
|------------------------|--------------------------------------------------------|-------------|---------------------------------------------------------------------|
|                        |                                                        |             | <b>Note:</b> For 9427 see the note below this table.                |
| 2749                   | 3490/Fxx, 3570, 358x, 9427, 7208/342                   | 18.0 meters | 49G6459<br><br><b>Note:</b> For 9427 see the note below this table. |
| 2749                   | 63A0                                                   |             | See device documentation to determine cable part numbers            |
| 2749                   | 7208/012, 7208/222                                     | 1.5 meters  | 52G0174                                                             |
| 2749                   | 7208/012, 7208/222                                     | 4.0 meters  | 59H3462                                                             |
| 2749                   | 7208/012, 7208/222                                     | 12.0 meters | 59H3463                                                             |
| 2749                   | 7208/232, 7208/234, 9348                               | 0.5 meters  | 06H6037                                                             |
| 2749                   | 7208/232, 7208/234, 9348                               | 4.0 meters  | 59H3460                                                             |
| 2749                   | 7208/232, 7208/234, 9348                               | 12.0 meters | 05H5543                                                             |
| 2749                   | 3995                                                   | 12.0 meters | 05H5543                                                             |
| 2782, 5702, 5703, 571A | 358x, 7206/VX2, 7207/122, 7208/345, 7210/020, 7210/025 | 1.5 meters  | 19P4508, or 19P4506 with 19P0482 interposer cable                   |
| 2782, 5702, 5703, 571A | 358x, 7206/VX2, 7207/122, 7208/345, 7210/020, 7210/025 | 2.5 meters  | 19P0279, or 35L1307 with 19P0482 interposer cable                   |
| 2782, 5702, 5703, 571A | 358x, 7206/VX2, 7208/345                               | 4.5 meters  | 19P0050                                                             |
| 2782, 5702, 5703, 571A | 358x, 7206/VX2, 7208/345                               | 10 meters   | 19P0048                                                             |
| 571B, 571F             | 57/86 or 57/87 expansion unit                          | 1 meter     | 36R2585                                                             |
| 571B, 571F             | 57/86 or 57/87 expansion unit                          | 3 meters    | 36R2576                                                             |
| 571B, 571F             | 57/86 or 57/87 expansion unit                          | 5 meters    | 36R2577                                                             |
| 571B, 571F             | 57/86 or 57/87 expansion unit                          | 10 meters   | 36R2578                                                             |
| 571B, 571F             | 57/86 or 57/87 expansion unit                          | 20 meters   | 36R2579                                                             |

**Notes:**

- ◆ All cables for the 9427 tape library must include an interposer (part 05H3834) on the device end of the cable.
- ◆ All cables for the 3996 and 399F attachment are the responsibility of the external device service.
- ◆ For specific 358X attachment cable information, refer to the specific device and model service documentation, or contact your next level of support.

**This ends the procedure.**

Parent topic: [Symbolic FRUs](#)

---

## FCCABLE

The fibre channel cable may be failing.

Use the part number on the cable to determine the part number to replace.

Parent topic: [Symbolic FRUs](#)

---

## FCCODE

An error has been detected in the fibre channel gateway device licensed internal code.

See the gateway device service guide for possible corrective actions.

Parent topic: [Symbolic FRUs](#)

---

## FCDEV

The attached fibre channel device or fiber channel gateway device is the failing item.

Is there a fibre channel gateway device between the fiber channel I/O adapter and the device?

- **No:** See the attached device maintenance information to determine the parts to replace. **This ends the procedure.**
- **Yes:** See symbolic FRU [FCGATE](#). **This ends the procedure.**

Parent topic: [Symbolic FRUs](#)

---

## FCGATE

The fibre channel gateway device is the failing item.

Use the gateway device service guide to determine the parts to replace.

Parent topic: [Symbolic FRUs](#)

---

## FCINTF

An error has been detected on the fibre channel interface.

The failure may be any component between and including the fibre channel IOA and the storage device. To continue diagnosis, use existing fibre channel service procedures or contact your next level of support.

Parent topic: [Symbolic FRUs](#)

---

## FCIOA

The fibre channel I/O adapter is the failing item.

Replace the fibre channel I/O adapter using the I/O adapter location information in the Service Action Log if it is available. If the location is not available, find the address of the I/O adapter (see [SRC address formats](#)). Use the address to find the location (see [Finding part locations](#)). If an I/O Processor SRC sent you here, replace the fibre channel I/O adapter associated with the I/O processor that logged the SRC.

**Parent topic:** [Symbolic FRUs](#)

---

## FCPORT

The Fibre Channel IOA port may be the failing item.

Perform the following:

1. If the system has logical partitions, perform this procedure from the logical partition that reported the problem. To determine if the system has logical partitions, go to [Determining if the system has logical partitions](#) before continuing with this procedure.
2. Access SST/DST by doing one of the following:
  - a. If you can enter a command at the console, access system service tools (SST). See [System Service Tools \(SST\)](#).
  - b. If you cannot enter a command at the console, perform an IPL to DST. See [Performing an IPL to DST](#).
  - c. If you cannot perform a type A or B IPL, perform a type D IPL from removable media.
3. Is the SRC 2765/2766/2787/280D/280E/2847/5704 3120 logged or been logged within 5 minutes of the SRC that sent you to this symbolic FRU?
  - ◆ **Yes:** Continue with the next step.
  - ◆ **No:** The Fibre Channel IOA port has not failed. See the next FRU in the SRC table. This ends the procedure.
4. Did you perform a D IPL to get to DST?
  - ◆ **Yes:** Continue with the next step.
  - ◆ **No:** Continue with step 6. This ends the procedure.
5. Use the Product Activity Log to get the resource name for the 3120 SRC. See [Using the Product Activity Log](#). Using the resource name, perform the following steps in DST/SST:
  - a. Select Start a service tool > Hardware service manager > System bus resources.
  - b. If the resource is an I/O processor, use Resources associated with IOP to find and display detail for the Fibre Channel I/O adapter. If the resource is a Fibre Channel I/O adapter, use Resources associated with the IOP for all type 2847 I/O processors to find and display the Fibre Channel I/O adapter.
  - c. Select the Display additional port information function key on the Auxiliary Storage Hardware Resource Detail display.
 

Does the Port status field indicate that the port is active?

    - ◆ **Yes:** Continue with step 7.
    - ◆ **No:** Continue with step 9. This ends the procedure.
6. Use the Service Action Log to get the resource name for the 3120 SRC. See [Using the Service Action Log](#). Using the resource name, perform the following steps in DST/SST:
  - a. Select Start a service tool > Hardware service manager > Locate resource by resource name.
  - b. Enter the resource name.
  - c. Select the Display detail option for the Fibre Channel I/O adapter on the Logical Hardware Resources display.
  - d. Select the Display additional port information function key on the Auxiliary Storage Hardware Resource Detail display.
 

Does the Port status field indicate that the port is "active"?

    - ◆ **Yes:** Continue with the next step.
    - ◆ **No:** Go to step 9.
7. The port is now active. Has a 1750/2105/2107 3002 SRC occurred around the time the problem was first reported?
  - ◆ **Yes:** Continue with the next step.
  - ◆ **No:** No further service actions are required. **This ends the procedure.**
8. A 1750/2105/2107 3002 has occurred, and the link has gone from not active to active. The Fibre Channel IOA port is functional. Choose from the following options:



- ◆ If the disk units that reported the 1750/2105/2107 3002 SRC are usable, then no further service actions are required. **This ends the procedure.**
  - ◆ If the disk units that reported the 1750/2105/2107 3002 SRC are not usable, then go back to the 1750/2105/2107 3002 FRU list and work with a FRU other than FCPORT. **This ends the procedure.**
9. Clean the Fibre Channel IOA wrap plug using the cleaning kit. See the [Part number catalog](#) for the part number. Follow the instructions in the Fiber Optic Cleaning Procedures (SY27-2604). If the wrap plug has been lost, order and clean a new one. See the [Part number catalog](#) for part number.
  10. Perform the following steps:
    - a. Install the wrap plug on the Fibre Channel IOA.
    - b. After the wrap plug has been installed, wait 5 seconds.
    - c. Choose from the following options:
      - ◇ If you are on the Additional Port Information display, use the Refresh function key.
      - ◇ If you are not already on the Additional Port Information display, use the instructions from step 6 to check if the port has become active.

Is the port status now "active"?

      - ◆ **Yes:** Continue with the next step.
      - ◆ **No:** Replace the Fibre Channel IOA. See symbolic FRU [FCIOA](#) for further instructions. **This ends the procedure.**
  11. Ask the customer whether the Fibre Channel IOA will attach devices now or whether the Fibre Channel IOA is to be used at a later time. Is the Fibre Channel IOA intended to attach devices at this time?
    - ◆ **No:** The wrap plug must be left installed on the Fibre Channel IOA when it is not in use. No further service actions are required. **This ends the procedure.**
    - ◆ **Yes:** Perform the following steps:
      - a. Unplug the wrap plug from the Fibre Channel IOA and wait until the port status becomes "Not active" using the Refresh function key on the Additional Port Information display. The failure has been isolated to the first link, which includes any of the cables or junctions between the Fibre Channel IOA port and the first Fibre Channel hub, switch, gateway, or device.
      - b. Use existing Fibre Channel service procedures to continue diagnosis of this first link until the port status becomes active, or contact your next level of support. **This ends the procedure.**

Parent topic: [Symbolic FRUs](#)

---

## FRPORT

The RIO controller or adapter on one end of the link may be the failing item.

If you were sent to this procedure as a result of a B700 6985 SRC, and this is the only FRU in the FRU list, then the system cannot see any I/O units on a RIO loop and there is at least one cable attached to a port on that loop. In this case, go to [\(A7xx, B7xx\) Licensed Internal Code \(LIC\) Reference Codes](#) and work from the full FRU list provided there.

**Note:** The other end of the link is given in the symbolic FRU [TOPORT](#).

**Note:** For this procedure, the terms "HSL I/O bridge" and "RIO adapter" are interchangeable.

1. Record the bus number (BBBB) in word 7 of the reference code (see [Breaking down a RIO/HSL or PCI bus reference code](#)).
2. Find the failing RIO node using one of the following procedures:

- ◆ [Finding the failing RIO node using AIX or Linux](#)
- ◆ [Finding the failing RIO node using the HMC](#)

**Parent topic:** [Symbolic FRUs](#)

**Finding the failing RIO node using**

**Finding the failing RIO node using AIX or Linux**

1. Determine which RIO loop the failing node is on (see [Converting the loop number to NIC port location labels](#)).
2. Identify each unit in the loop by following the cable.
3. Power down the system and remove all expansion units in the loop that starts and ends at the ports given in the previous step. If there is a base I/O unit on that loop, leave only that unit connected to the system unit.
4. Power on the system to partition standby and check for the same SRC that sent you here. Did the SRC reoccur?
  - ◆ **No:** Power down the system and add the next unit in the original loop. Repeat step 3.
  - ◆ **Yes:** The RIO node in the last I/O unit added is possibly the failing item. Use the RIO adapter information in the locations tables for the unit with the possible failing RIO adapter and go to [Finding part locations](#). Select the model or expansion unit you are working with, and find the location in the locations tables to determine the replacement procedure and physical location of the FRU. **This ends the procedure.**

**Finding the failing RIO node using the HMC**

Perform the following from Service Focal Point on the HMC:

1. Select the Service Utilities task.
2. In the Service Utilities window, click the system you are working on. Then, from the selected drop down menu, select View RIO Topology.
3. In the Current Topology area, scroll down until you find data for the RIO loop number with which you are working.
4. Each line in that RIO loop represents a RIO node. Find the first one with a leading port status of failed. Use that adapter information, and go to [Finding part locations](#). Select the model or expansion unit with which you are working, and find the location in the locations tables to determine the replacement procedure and physical location of the FRU.

**This ends the procedure.**

---

## FWADIPL

Look here for information about FWADIPL symbolic FRU.

Perform the following.

1. Contact your network administrator to verify that the bootp server is correctly configured for this client.
2. Check the network connection. If the network connections are OK, retry the operation. If there is no network connection, contact the network administrator.
3. If there are no problems with the bootp server or the network connections, replace the adapter from which you are trying to boot.

**This ends the procedure.**

Parent topic: [Symbolic FRUs](#)

---

## FWCD1

Look here for information about FWCD1 symbolic FRU.

Perform the following procedure.

1. If the problem persists, the CD in the USB CD-ROM drive might not be readable. Remove the CD and insert another CD.
2. If the problem persists after replacing the CD-ROM, replace the USB CD-ROM drive.
3. Replace the USB adapter the drive is attached to.

**This ends the procedure.**

Parent topic: [Symbolic FRUs](#)

---

## FWCD2

Look here for information about FWCD2 symbolic FRU.

Perform the following procedure.

1. Check for server firmware updates. Apply if available.
2. If the problem persists, replace the USB CD-ROM drive.
3. Replace the USB adapter to which the drive is attached.

**This ends the procedure.**

Parent topic: [Symbolic FRUs](#)

---

## FWCONS

Look here for information about FWCONS symbolic FRU.

Perform the following.

1. If your server has an attached console, but the console display is not working, go to one of the following:
  - ◆ [All display problems in AIX server or AIX partition symptoms](#)

◆ [All display problems in Linux server or Linux partition symptoms](#)

2. If you can see selection screens on the terminals, press the appropriate key on the input device within 60 seconds. If the console does not respond to the keystroke:
  - a. If you are selecting the console with a keyboard attached to the system, replace the keyboard, then replace the service processor (see [Finding part locations](#)).
  - b. If you are selecting the console with an ASCII terminal, suspect the terminal. Use the problem determination procedures for the terminal.

**Note:** The ASCII terminal settings should be:

- 19,200 baud
- No parity
- 8 data bits
- 1 stop bit

**This ends the procedure.**

**Parent topic:** [Symbolic FRUs](#)

---

## FWENET

Look here for information about FWENET symbolic FRU.

Perform the following.

1. Verify that the MAC address is properly programmed in the adapter's EPROM.
2. Replace the adapter specified by the location code.

**This ends the procedure.**

**Parent topic:** [Symbolic FRUs](#)

---

## FWFLASH

Look here for information about FWFLASH symbolic FRU.

Perform the following.

1. Reboot the server or partition.
2. Reflash the server firmware (see [Getting fixes](#)).
3. Reboot the failing partition.

**This ends the procedure.**

**Parent topic:** [Symbolic FRUs](#)

---

## FWFWPBL

Look here for information about FWFWPBL symbolic FRU.

Perform the following.

1. Check for platform firmware updates. Apply if available.
2. Contact service support.

**This ends the procedure.**

**Parent topic:** [Symbolic FRUs](#)

---

## FWHANG

Symbolic FRU FWHANG is not supported at this time.

**Parent topic:** [Symbolic FRUs](#)

---

## FWHOST

Look here for information about FWHOST symbolic FRU.

If the system is not connected to an active network or if the target server is inaccessible (this can also result from incorrect IP parameters being supplied), the system will still attempt to boot and, because timeout durations are necessarily long to accommodate retries, the system may appear to be hung.

Perform the following.

Restart the system and get to the SMS utilities. In the utilities menus, check the following:

- Is the intended boot device correctly specified in the boot list?
- Are the IP parameters correct?
- Verify the network connection (the network could be down).
- Have the network administrator verify the server configuration for this client.
- Attempt to "ping" the target server using the SMS Ping utility.

**This ends the procedure.**

**Parent topic:** [Symbolic FRUs](#)

## FWIDE1

Look here for information about FWIDE1 symbolic FRU.

Perform the following.

1. Replace the media in the device specified by the location code.
2. Replace the device specified by the location code.

**This ends the procedure.**

Parent topic: [Symbolic FRUs](#)

---

## FWIDE2

Look here for information about FWIDE2 symbolic FRU.

Perform the following.

1. Verify that the signal and power cables are properly attached to the device specified by the location code. After they have been verified and repaired if necessary, retry the operation.
2. If the problem persists, the media in the device might not be readable. Remove the media and try another copy.
3. Replace the device specified by the location code.

**This ends the procedure.**

Parent topic: [Symbolic FRUs](#)

---

## FWIPIPL

Look here for information about FWIPIPL symbolic FRU.

Perform the following.

1. Contact your network administrator to verify that the network addresses on the server and gateway are correct.
2. Use the System Management Services menu to correct them on the server if necessary.

**This ends the procedure.**

Parent topic: [Symbolic FRUs](#)

---

## FWLPAR

Look here for information about FWLPAR symbolic FRU.

Perform the following.

1. If a location code was reported with the error **Probing failed for the PCI slot connector**:
  - a. Replace the PCI card in the connector specified by the location code. If this does not resolve the problem, replace the I/O planar on which the slot connector is located.
  - b. Check for adapter firmware updates if this error occurred during a hot plug operation. Apply if available. If there are no updates available, replace the adapter. If this does not resolve the problem, replace the I/O planar on which the slot connector is located.
  - c. Check for platform firmware updates. Apply the update if there is one available.
2. If no location code was reported with the error: The connector was not found.
  - a. Check for platform firmware updates; apply if available.
  - b. If no updates are available, replace the I/O planar specified by the location code.

**This ends the procedure.**

Parent topic: [Symbolic FRUs](#)

---

## FWMBOOT

This checkpoint appears on the operator panel when partition firmware has entered the boot devices menu in the SMS because the multi-boot flag was turned on.

The firmware is waiting for input from the user. If the firmware console is not open, the user cannot see the boot devices menu. In this case, the user might mistakenly assume that the system is hung. System firmware only progresses past this point when the user provides the required input.

Parent topic: [Symbolic FRUs](#)

---

## FWNIM

If this error occurs during the installation of AIX via a process called a NIM push, the set\_bootlist attribute may not have been set correctly on the NIM master.

See the appropriate *AIX 5.x Installation Guide and Reference* for the level of AIX that is being installed for more information.

If this error occurs at any other time, perform the following:

1. Check for platform firmware updates. Apply if available.
2. Call service support.

**This ends the procedure.**

Parent topic: [Symbolic FRUs](#)

---

## **FWNVR1**

An error reported against the NVRAM can be caused by low battery voltage and (more rarely) power outages that occur during normal system usage.

With the exception of the BA170000 error, these errors are warnings that the NVRAM data content had to be reestablished and do not require a FRU replacement unless the error is persistent. When one of these errors occurs, system customization information (the boot list, for example) has been lost, and the system may need to be re-configured.

If the error is persistent, replace the service processor (see symbolic FRU [SVCPROC](#)).

**This ends the procedure.**

Parent topic: [Symbolic FRUs](#)

---

## **FWNVR2**

Look here for information about FWNVR2 symbolic FRU.

If the error is persistent, replace the service processor (see symbolic FRU [SVCPROC](#)).

**This ends the procedure.**

Parent topic: [Symbolic FRUs](#)

---

## **FWNVR3**

Execution of a command line within the nvram configuration variable *nvramrc*(script) resulted in a "throw" being executed.

This script can be modified by the system firmware SMS utilities, the operating system, PCI adapter ROM code or utility, or an operator (via the open firmware script editing command **nvedit**).

It may not be possible to resolve the problem without a detailed analysis of the NVRAM script, the current system configuration, and the device tree contents.

1. The problem can be caused by a SCSI adapter whose SCSI bus ID has been changed from the default setting no longer appearing in the system. This can be caused either by removing a SCSI adapter, or a problem with a SCSI adapter.
  - a. Select option 5, Change SCSI settings, on the SMS main menu. Then on the SCSI utilities menu, select option 2, Change SCSI ID.
    - i. Verify the list of SCSI controllers/adapters. If the list is not correct, suspect a problem with the adapter(s) that are installed but not listed.
    - ii. Select the option to "Save" the configuration information.
    - iii. Restart the system.
  - b. If the problem persists, boot the operating system and verify the SCSI bus IDs of the SCSI controllers, and correct if necessary.
  - c. Restart the system.
2. Contact your service support representative for further assistance.



**This ends the procedure.**

Parent topic: [Symbolic FRUs](#)

---

## FWPCI1

Look here for information about FWPCI1 symbolic FRU.

Perform the following procedure.

1. If the location code identifies a slot:
  - a. Check for adapter firmware updates. Apply the update if one is available.
  - b. Replace the adapter.
  - c. Check for platform firmware updates. Apply the update if one is available.
2. If the location code identifies an I/O planar:
  - a. Check for platform firmware updates. Apply the update if one is available.
  - b. Replace the I/O planar.
3. Call service support.

**This ends the procedure.**

Parent topic: [Symbolic FRUs](#)

---

## FWPCI2

Look here for information about FWPCI2 symbolic FRU.

Perform the following procedure.

1. If the location code identifies a slot:
  - a. Check for adapter firmware updates. Apply the update if one is available.
  - b. Check the cabling to the adapter (in particular, the adapters that have serial ports). Serial ports may require null modems or special cabling configurations to avoid connecting driver outputs together. This may create a PCI power problem and force the adapter to be de-configured.
  - c. Use the hot plug service aid to re-seat the adapter specified by the location code (see [PCI adapter](#) in the [Installing features and replacing parts](#) topic to exchange a PCI adapter while powered on). If re-seating the adapter fixes the problem, perform the repair checkout procedure. If the problem is not resolved, go to step 1.d.
  - d. Use the hot plug task to move the adapter to another slot (behind another PCI bridge). The "I/O Subsystem PCI and PCI-X PHB and PCI and PCI-X Slot Locations" identifies the PCI bridges and associated slots.
2. If the adapter is successfully re-configured in the new slot (behind another PCI bridge), the slot in which the adapter was originally plugged is bad:
  - a. Replace the I/O backplane assembly that contains the slot in which the adapter was plugged.
3. Replace the adapter if the adapter does not successfully re-configure into the new slot. **This ends the procedure.**

4. If the adapter is successfully re-configured in the new slot (behind another PCI bridge), the slot in which the adapter was originally plugged is bad:
  - a. Replace the system backplane.
5. Replace the adapter if the adapter does not successfully re-configure into the new slot. **This ends the procedure.**

Parent topic: [Symbolic FRUs](#)

---

## FWPCI3

Look here for information about FWPCI3 symbolic FRU.

Perform the following procedure.

1. If the location code identifies a slot:
  - a. Check the cabling to the adapter (in particular, the adapters that have system ports). System ports may require null modems or special cabling configurations to avoid connecting driver outputs together. This may create a PCI power problem and force the adapter to be de-configured.
  - b. Move the adapter to another slot (behind another PCI bridge).
  - c. Check for adapter firmware updates. Apply the update if one is available.
  - d. Replace the adapter.
  - e. Check for platform firmware updates. Apply the update if one is available.
  - f. Replace the I/O backplane.
2. If the location identifies an I/O backplane:
  - a. Check for platform firmware updates. Apply the update if one is available.
  - b. Replace the I/O backplane.

**This ends the procedure.**

Parent topic: [Symbolic FRUs](#)

---

## FWPCI4

Look here for information about FWPCI4 symbolic FRU.

Perform the following.

1. If a location code is associated with the checkpoint, replace the adapter identified by the location code.
2. If no location code is specified, see [PFW1542: I/O Problem Isolation Procedure](#).

**This ends the procedure.**

Parent topic: [Symbolic FRUs](#)

---

## FWPCI5

Look here for information about FWPCI5 symbolic FRU.

Perform the following.

Is a location code associated with the checkpoint?

- **No:** Go to [PFW1548: Memory and processor subsystem problem isolation procedure](#). **This ends the procedure.**
- **Yes:** Replace the following, one at a time, until the problem is resolved (see [Finding part locations](#)):

- a. FRU identified by the location code
- b. I/O backplane

**This ends the procedure.**

Parent topic: [Symbolic FRUs](#)

---

## FWPCI6

Look here for information about FWPCI6 symbolic FRU.

The last character of the progress code (checkpoint) in which the system is hanging indicates which PCI slot the system was probing at the time the hang occurred. For example, E251 indicates PCI slot 1, E252 indicates slot 2, and so on.

For the PCI slot identified by the progress code, perform the following procedure:

1. Power down the system.
2. Reseat the adapter in the specified slot, then power up the system. Does the problem occur again?
  - ◆ **Yes:** Go to the next step.
  - ◆ **No: This ends the procedure.**
3. Power down the system and remove the adapter from the specified slot, then power on the system. Does the problem occur again?
  - ◆ **Yes:** Replace the system planar (see [Finding part locations](#)). Go to [MAP 0410: Repair checkout](#).
  - ◆ **No:** Replace the adapter that you removed. Go to [MAP 0410: Repair checkout](#).

**This ends the procedure.**

Parent topic: [Symbolic FRUs](#)

---

## FWPTR

Values normally found in nonvolatile storage that point to the location of an operating system were not found.

This can happen for two reasons: either your operating system doesn't support storing the values, or some events occurred that caused the system to lose non-volatile storage information (drainage or replacement of the battery). If you are running AIX, this information can be reconstructed by running the **bootlist** command specifying the device that the operating system is installed on. Please refer to your AIX documentation for the syntax and usage of the **bootlist** command.

In order to boot the operating system so that the above-mentioned values can be reconstructed, power the system down and power it back up again. This should cause the system to look for the operating system in the device contained in the custom boot list or in the default boot list, depending on the condition of the system. If this is not successful, modify the boot sequence (also known as the boot list) to include devices that are known to contain a copy of the operating system. This can be accomplished by using the System Management Services menus. For example, select a hard disk known to have a copy of the operating system as the first and only device in the boot sequence (boot list) and boot the system.

**This ends the procedure.**

Parent topic: [Symbolic FRUs](#)

---

## FWPWD

Look here for information about FWPWD symbolic FRU.

You should be able to see the system prompt on the hardware console.

If your server has an attached console, but the console display is not working, click the appropriate link for the operating system you are running:

- If your server is running AIX, [Display problems in the AIX Fast Path MAP](#)
- If your server or partition is running Linux, go to [Display Problems in the Linux Fast Path MAP](#)

**This ends the procedure.**

Parent topic: [Symbolic FRUs](#)

---

## FWR IPL

Look here for information about FWPCI3 symbolic FRU.

Perform the following.

If a supported adapter is installed:

1. Replace the adapter.
2. Replace the I/O drawer backplane in the drawer in which the adapter is plugged.

If there are no supported LAN adapters installed in a full system partition, install one and reboot the system. If a supported LAN adapter is not assigned to the partition in a server running multiple partitions, deactivate the partition, assign one to the partition, then reactivate the partition.

**This ends the procedure.**

Parent topic: [Symbolic FRUs](#)

---

## FWSCSI1

Look here for information about FWSCSI1 symbolic FRU.

Before replacing any system components:

1. Ensure that the controller and each device on the SCSI bus is assigned a unique SCSI ID.
2. Ensure that the SCSI bus is properly terminated.
3. Ensure that the SCSI signal and power cables are securely connected and are not damaged.

The location code information is required to identify the ID of SCSI device failures as well as to indicate the location of the controller to which the device is attached. Check the system error logs to determine the location code information associated with the error code.

1. Replace the SCSI device.
2. Replace the SCSI cable.
3. Replace the SCSI controller.

**This ends the procedure.**

Parent topic: [Symbolic FRUs](#)

---

## FWSCSI2

Look here for information about FWSCSI1 symbolic FRU.

Before replacing any system components:

1. Ensure that the controller and each device on the SCSI bus is assigned a unique SCSI ID.
2. Ensure that the SCSI bus is properly terminated.
3. Ensure that the SCSI signal and power cables are securely connected and are not damaged.

The location code information is required to identify the ID of SCSI device failures as well as to indicate the location of the controller to which the device is attached. Check the system error logs to determine the location code information associated with the error code.

1. Replace the media (if it is a device with removable media).
2. Replace the SCSI device.

**This ends the procedure.**

Parent topic: [Symbolic FRUs](#)

---

## FWSCSI3

Look here for information about FWSCSI1 symbolic FRU.

Before replacing any system components:

1. Ensure that the controller and each device on the SCSI bus is assigned a unique SCSI ID.
2. Ensure that the SCSI bus is properly terminated.
3. Ensure that the SCSI signal and power cables are securely connected and are not damaged.

The location code information is required to identify the ID of SCSI device failures as well as to indicate the location of the controller to which the device is attached. Check the system error logs to determine the location code information associated with the error code.

1. Replace the SCSI device.

**This ends the procedure.**

Parent topic: [Symbolic FRUs](#)

---

## FWSCSI4

Look here for information about FWSCSI1 symbolic FRU.

Before replacing any system components:

1. Ensure that the controller and each device on the SCSI bus is assigned a unique SCSI ID.
2. Ensure that the SCSI bus is properly terminated.
3. Ensure that the SCSI signal and power cables are securely connected and are not damaged.

The location code information is required to identify the ID of SCSI device failures as well as to indicate the location of the controller to which the device is attached. Check the system error logs to determine the location code information associated with the error code.

1. Replace the media (if a device with removable media).
2. Replace the SCSI device.

**This ends the procedure.**

Parent topic: [Symbolic FRUs](#)

---

## FWSCSI5

Look here for information about FWSCSI5 symbolic FRU.

Before replacing any system components:

1. Ensure that the controller and each device on the SCSI bus is assigned a unique SCSI ID.
2. Ensure that the SCSI bus is properly terminated.
3. Ensure that the SCSI signal and power cables are securely connected and are not damaged.

The location code information is required to identify the ID of SCSI device failures as well as to indicate the location of the controller to which the device is attached. Check the system error logs to determine the location code information associated with the error code.

1. Replace the SCSI device.
2. Replace the SCSI cable.
3. If the missing SCSI devices are connected to the same backplane, replace the SCSI backplane.
4. Replace the SCSI controller.

**This ends the procedure.**

Parent topic: [Symbolic FRUs](#)

---

## FWSCSIH

Look here for information about FWSCSIH symbolic FRU.

If a location code is available, follow the repair actions listed for error code BA090001 (see [FWSCSI1](#)).

If no location code is available, go to [PFW1548: Memory and processor subsystem problem isolation procedure](#).

**This ends the procedure.**

Parent topic: [Symbolic FRUs](#)

---

## FWVTHMC

Look here for information about FWVTHMC symbolic FRU.

1. The partition firmware is waiting for a virtual terminal to be opened on the HMC. Open a virtual terminal.
2. If a virtual terminal is open, the user might have entered a CTRL-S key sequence to stop the scrolling of data off the screen. If this is the case, enter a CTRL-Q key sequence to resume scrolling.
3. Check the ethernet connection between the HMC and the managed system.
4. Reboot the HMC.
5. There may be a hardware problem with the HMC. Refer to the HMC maintenance guide.
6. There may be a hardware problem with the service processor in the managed system. Check the service action event log in Service Focal Point for error codes that indicate a problem with the ethernet ports on the service processor. Take the appropriate actions based on the error codes that you find.

**This ends the procedure.**

Parent topic: [Symbolic FRUs](#)

---

## HCA

The failing component is the Host Channel Adapter.

Use the table below to determine what FRU to replace and how to replace it.

| Model or expansion unit             | Name of symbolic FRU to locate                       | Link to locations                                                                   |
|-------------------------------------|------------------------------------------------------|-------------------------------------------------------------------------------------|
| ESCALA PL 250T/R                    | InfiniBand Host Channel Adapter:<br>System Backplane | <a href="#">Locations</a> <a href="#">model ESCALA PL 250T/R</a>                    |
| ESCALA PL 450T/R                    | InfiniBand Host Channel Adapter:<br>System Backplane | <a href="#">Locations</a> <a href="#">model ESCALA PL 450T/R, server,</a>           |
| ESCALA PL 850R/PL 1650R/R+          | InfiniBand Host Channel Adapter:<br>Expansion card   | <a href="#">Locations</a> <a href="#">model ESCALA PL 850R/PL 1650R/R+</a>          |
| 5/75,                               | InfiniBand Host Channel Adapter:<br>System Backplane | <a href="#">Locations</a> <a href="#">model 5/75.</a>                               |
| ESCALA PL 3250R and ESCALA PL 6450R | InfiniBand Host Channel Adapter:<br>Expansion card   | <a href="#">Locations</a> <a href="#">model ESCALA PL 3250R and ESCALA PL 6450R</a> |

Parent topic: [Symbolic FRUs](#)

---

## HMCLIC

Firmware on the Hardware Management Console (HMC) must be replaced.

See [HMC fixes](#) to obtain a new level of HMC firmware.

Parent topic: [Symbolic FRUs](#)

---

## HMCMTWK

Multiple connections to peer HMCs have been lost.

1. Perform the following from the HMC reporting the connection errors:
  - a. In the navigation area, select Service Applications > Service Focal Point.
  - b. Select Service Utilities from the Service Focal Point display.
  - c. View the Actions menu and select View Network Topology.
  - d. Are the peer HMCs with the missing connection present in the topology?
    - ◇ **No:** Continue with the next step.
    - ◇ **Yes:** The problem was temporary and has resolved itself. **This ends the procedure.**
2. Is the HMC that reported the connection errors also reporting a hardware error with a network adapter?
  - ◆ **No:** Continue with the next step.
  - ◆ **Yes:** Service this network adapter error. **This ends the procedure.**
3. Verify that each peer HMC with a missing connection is powered on and that its ethernet connections are secure and functioning. Does the problem persist?
  - ◆ **No:** **This ends the procedure.**
  - ◆ **Yes:** Continue with the next step.
4. Have the customer verify that their network is operating properly. If the problem still persists, contact your next level of support.

**This ends the procedure.**



Parent topic: [Symbolic FRUs](#)

---

## HMCNTWK

A connection to a peer HMC (indicated in the location code) has been lost.

1. Perform the following from the HMC reporting the connection error:
  - a. In the navigation area, select Service Applications > Service Focal Point.
  - b. Select Service Utilities from the Service Focal Point display.
  - c. View the Actions menu and select View Network Topology.
  - d. Is the peer HMC with the missing connection present in the topology?
    - ◇ **No:** Continue with the next step.
    - ◇ **Yes:** The problem was temporary and has resolved itself. **This ends the procedure.**
2. Verify that the peer HMC with the missing connection is powered on and that its ethernet connections are secure and functioning. Does the problem persist?
  - ◆ **No: This ends the procedure.**
  - ◆ **Yes:** Continue with the next step.
3. Is either the HMC that reported the problem or the peer HMC with the missing connection reporting a hardware error with a network adapter?
  - ◆ **No:** Continue with the next step.
  - ◆ **Yes:** Service this network adapter error. **This ends the procedure.**
4. Have the customer verify that their network is operating properly. If the problem still persists, contact your next level of support.

**This ends the procedure.**

Parent topic: [Symbolic FRUs](#)

---

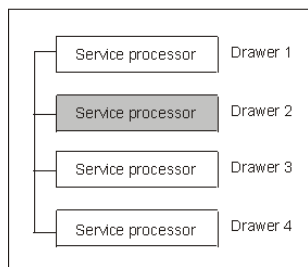
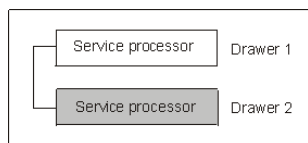
## HMUX

Use this procedure to determine the failing error path and associated FRUs for ESCALA PL 1650R-L+ or 5/7x single and multi-drawer systems.

For reference codes associated with this symbolic FRU, the location code information in the associated error log will point to the service processor that generated the error. The reference code will point to the drawer the service processor suspects caused the error. Because of possible service processor failover in multiple service processor systems, use the location code information in the reference code error log to determine which service processor generated the error. Do not use the service processor that is currently active on the system to determine the error path and FRU list associated with this error.

1. Is the reference code you are working with 1xxx 3200, 1xxx 3201, 1xxx 3202, or 1xxx 3203?
  - No:
    - Return to the [Start of call procedure](#).
  - Yes:
    - Perform the following:
      - a. Determine which service processor indicated the error by matching location code information in the error log to the drawer.
      - b. Determine which drawer the service processor believes caused the error. If the service processor generated reference code 1xxx 3200, go to drawer 1. If the service processor generated reference code 1xxx 3201, go to drawer 2. If the service processor generated reference code 1xxx 3202, go to drawer 3. If the service processor generated reference code 1xxx 3203, go to drawer 4. The following illustrations shows a two drawer ESCALA PL 1650R-L+ and a four drawer 5/7x.

### Service provider information



iphau097

- c. To determine the potential error path and FRU list, compare the service processor location to the drawer error location.

**Note:** Your system problem might be caused by one of the following listed FRUs:

- The service processor cable connecting the drawers (ensure that both ends of this cable are correctly seated before replacing)
- The backplane of the tower indicated by the reference code
- The system backplane of the drawer the reporting service processor resides in
- The service processor that reported the error

2. Did your system produce reference code 1xxx 3200?

No:

Continue to the next step.

Yes:

Is your system a single drawer ESCALA PL 1650R-L+ or 5/7x with no service processor cable installed?

No:

Continue to the next step.

Yes:

Replace the system drawer system backplane. If the reference code persists, replace the service processor. If necessary, refer to [Finding part locations](#).

**Note:** For information on understanding specific sections of a location code string refer to [Understanding location codes](#).

3. Using the reference code, 1xxx 3200, 1xxx 3201, 1xxx 3202, or 1xxx 3203, determine which drawer the failure was reported against. Use error log location code information to determine which system drawer the service processor that reported the error is located in.

- a. Replace the system drawer backplane in the system drawer the problem was reported against. If necessary, refer to [Finding part locations](#).

**Note:** For information on understanding specific sections of a location code string refer to [Understanding location codes](#).

- b. If the problem persists, replace the following parts, in the order listed, until the problem is resolved:

- i. Service processor cable connecting the system drawers

**Note:** Do not replace the service processor cable at this time if the system drawer contains the service processor that reported the error, and it is the same system drawer the service processor reported the error against.

- ii. The system backplane in the system drawer the service processor that reported the failure resides in
- iii. The service processor that reported the failure
- iv. If not previously replaced, the service processor cable connecting the system drawers

Parent topic: [Symbolic FRUs](#)

---

## HP5A575

This procedure refers to a high performance switch (HPS) switch network interface (SNI) in a 5/75 server.

You might find this FRU listed in the *Part number* field in the FRU list in a Serviceable Event Details panel. You need to follow this procedure only after you isolate the cause of the serviceable event to an HPS SNI. Two reasons occur for a Symbolic FRU to be displayed instead of a part number:

- The Vital Product Data (VPD) is unavailable, so the part number is unknown.
- The location code for the SNI is not fully known. In this case, the location code includes number sign characters (#) as placeholders. (for example, U####.###.#####-P#-C#).

Valid SNI location codes do not include any number sign characters. When you have a valid SNI code, look up the part number for a 2-port SNI in the Parts Catalog section of the [45H/W4 Switch Planning, Installation, and Service for POWER5 technology based servers](#) manual.

When the SNI location code is not valid or is not fully known, you need to determine both the location of the SNI and the part number. To help you determine the location of the SNI, you must use either the other side of the cable or the provided frame and slot location.

The basic flow of the following procedure consists of these actions:

1. Write down specific information about the frame, slot, reference code, and reference code extension.
2. Determine the location of the SNI.
3. Verify that you have identified the correct part.
4. Write down the part number.

**Note:** After you complete this procedure but before you continue with your service action, make sure to read the notes in [Before you proceed](#).

To perform this procedure, complete the following steps:

1. Record the frame and slot information from the text in the Serviceable Event Details panel.
2. Record the reference code for the Serviceable Event.
3. Record the reference code extension for the Serviceable Event.
4. Review the information in the FRU list. Does the Serviceable Event list an SNI FRU and a switch port connection card (SPCC) FRU?
  - ◆ **No:** Go to step 5.
  - ◆ **Yes:** Determine if you have a valid location code for the SPCC.
    - a. Do you have a valid location code for the SPCC?
      - **No:** Go to step 4.b.
      - **Yes:** Do the following:

- i. Record the location of the SPCC that has a valid location.
  - ii. Go to the HPSNM Switch Topology View on the CSM Management Server Console, find the SPCC location that you wrote down from the previous step, and click the SPCC location.
  - iii. Click Selected-Properties.
  - iv. Click the Connected-To tab.
  - v. Is the location code valid in the Connected-To tab?
    - ◆ **Yes:** The location code in the Connect-To tab is the location code for the SNI. **This ends the procedure.**
    - ◆ **No:** Refer to your cable planning documentation or a cable label to determine which SNI is connected to this SPCC port. **This ends the procedure.**
- b. You do not have a valid location code for either the SNI or the SPCC. Does the reference code that you wrote down in step 2 begin with BB10, BB20, or BB50?
- **No:** Go to step 4.c.
  - **Yes:** The frame and slot information that you wrote down in step 1 indicate the location of the switch.

**Note:** The SPCC card number (Cx) in the location code of the SPCC should be valid.

- i. Go to the HPSNM Switch Topology View on the CSM Management Server Console and find the SPCC location that you recorded previously. Click on that row.
  - ii. Click Selected-Properties.
  - iii. Click the Connected-To tab. Is the location code valid in the Connected-To tab?
    - ◆ **Yes:** The location code listed in the Connected-To tab is the location code for the SNI. **This ends the procedure.**
    - ◆ **No:** Refer to your cable planning documentation or a cable label, or trace the cable to determine which SNI is connected to this SPCC port.
- c. You do not have a valid location code for either the SNI or the SPCC. Does the reference code that you wrote down in step 2 begin with BB30 or BB40?
- **No:** Go to step 5.
  - **Yes:** The reference code extension for the serviceable event that you wrote down in step 3 indicates the logical location of the port on the SNI that reported the problem.
    - i. Break down the reference code extension. Use [Breaking down a reference code for an SNI](#) as a guide. Write down the frame number, slot number, chip number and port number.
    - ii. Go to the HPSNM Endpoint View on the CSM Management Server and find the row that matches the reference code extension data from the previous step. (The chip number is labeled **Adapter number** in the GUI.) Click on that row.
    - iii. Is the location code valid in the HPSNM Endpoint View?
      - ◆ **Yes:** The location code in the GUI is the location code of the SNI. **This ends the procedure.**
      - ◆ **No:** Do the following:
        1. Click Selected-Properties.
        2. Click the Connected-To tab. Is the location code valid in the Connected-To tab?
          - **Yes:** The location code listed in the Connected-To tab is the location code for the SPCC to which the SNI is connected. **This ends the procedure.**
          - **No:** Determine the SPCC to which the SNI is connected.
            - a. Write down the frame and slot of this SPCC. This frame and slot indicate the location of the switch planar to which the SPCC is connected.

- b. The SPCC card number (Cx) in the location code should be valid. Use this to find the specific SPCC card that is plugged into the switch planar that you identified in the previous step.
  - iv. Use your cable planning documentation or a cable label, or trace the cable to determine which SNI is connected to this SPCC port. **This ends the procedure.**
5. Review the information in the FRU list. The Serviceable Event lists one SNI FRU and no SPCC FRU.

**Note:** The frame and slot in the Serviceable Event Text that you recorded in step 3 indicates where to locate the server that contains the SNI.

- a. Break down the reference code extension. Use [Breaking down a reference code for an SNI](#) as a guide. Write down the frame number, slot number, chip number and port number.
- b. Go to the HPSNM Endpoint View on the CSM Management Server and find the row that matches the reference code extension data from the previous step. (The chip number is labeled **Adapter number** in the GUI.) Click on that row.
- c. Click Selected-Properties.
- d. Is the location code valid in the Selected-Properties panel?
  - ◊ **Yes:** The location code listed in the Selected-Properties panel is the location code for the SNI. **This ends the procedure.**
  - ◊ **No:** Does the server in the specified frame and slot contain more than one SNI card?
    - **No:** Only one SNI card is in the server. The location code listed in the Selected-Properties panel is the location code for SNI. **This ends the procedure.**
    - **Yes:** More than one SNI card is in the server. Call your next level of support to help find the correct SNI. **This ends the procedure.**

**Parent topic:** [Symbolic FRUs](#)

**Breaking down a reference code for an SNI**

The following table shows how to break down a sample reference code for a switch network interface (SNI): 0000000040512330. The data for this reference code are frame 4, slot 5, chip 3, port 0.

Table 1. Breaking down SNI reference code 0000000040512330

| 5 chars    | 1 char  | 3 chars      | 2 chars     | 2 chars  | 1 char | 1 char | 1 char |
|------------|---------|--------------|-------------|----------|--------|--------|--------|
| Reserved=0 | Network | Frame number | Slot number | Reserved | Card   | Chip   | Port   |
| 00000      | 0       | 004          | 05          | 12       | 3      | 3      | 0      |

**Before you proceed**

**Notes:**

- 1. Before you replace the SNI, make sure that you run diagnostics.

2. Try to verify the presence of a flashing LED on the SNI card that you are planning to service. The lack of a flashing LED is not a positive indicator that this is not the correct switch.
3. You can get the part number by looking on the part itself, then cross-referencing that number to the Parts Catalog section of the [45H/W4 Switch Planning, Installation, and Service for POWER5 technology based servers](#) manual. The part number should be for a 2-link SNI.

## HPSA590

This procedure refers to a high performance switch (HPS) switch network interface (SNI) in an ESCALA PL 3250R or ESCALA PL 6450R server.

You might find this FRU listed in the *Part number* field in the FRU list in a Serviceable Event Details panel. You need to follow this procedure only after you isolate the cause of the serviceable event to an HPS SNI. Two reasons occur for a Symbolic FRU to be displayed instead of a part number:

- The Vital Product Data (VPD) is unavailable, so the part number is unknown.
- The location code for the SNI is not fully known. In this case, the location code includes number sign characters (#) as placeholders. (for example, U####.###.#####-P#-C#).

Valid SNI location codes do not include any number sign characters. When you have a valid SNI code, look up the part number for a 1-port SNI in the Parts Catalog section of the [45H/W4 Switch Planning, Installation, and Service for POWER5 technology based servers](#) manual.

When the SNI location code is not valid or is not fully known, you need to determine both the location of the SNI and the part number. To help you determine the location of the SNI, you must use either the other side of the cable or the provided frame and slot location.

The basic flow of the following procedure consists of these actions:

1. Write down specific information about the frame, slot, reference code, and reference code extension.
2. Determine the location of the SNI.
3. Verify that you have identified the correct part.
4. Write down the part number.

**Note:** After you complete this procedure but before you continue with your service action, make sure to read the notes in [Before you proceed](#).

To perform this procedure, complete the following steps:

1. Record the frame and slot information from the text in the Serviceable Event Details panel.
2. Record the reference code for the Serviceable Event.
3. Record the reference code extension for the Serviceable Event.
4. Review the information in the FRU list. Does the Serviceable Event list an SNI FRU and a switch port connection card (SPCC) FRU?
  - ◆ **No:** Go to step 5.
  - ◆ **Yes:** Determine if you have a valid location code for the SPCC.
    - a. Do you have a valid location code for the SPCC?
      - **No:** Go to step 4.b.
      - **Yes:** Do the following:
        - i. Record the location of the SPCC that has a valid location.
        - ii. Go to the HPSNM Switch Topology View on the CSM Management Server Console, find the SPCC location that you wrote down from the previous step, and click the SPCC location.

- iii. Click Selected-Properties.
  - iv. Click the Connected-To tab.
  - v. Is the location code valid in the Connected-To tab?
    - ◆ **Yes:** The location code in the Connect-To tab is the location code for the SNI. **This ends the procedure.**
    - ◆ **No:** Refer to your cable planning documentation or a cable label to determine which SNI is connected to this SPCC port. **This ends the procedure.**
- b. You do not have a valid location code for either the SNI or the SPCC. Does the reference code that you wrote down in step 2 begin with BB10, BB20, or BB50?
- **No:** Go to step 4.c.
  - **Yes:** The frame and slot information that you wrote down in step 1 indicate the location of the switch.

**Note:** The SPCC card number (Cx) in the location code of the SPCC should be valid.

- i. Go to the HPSNM Switch Topology View on the CSM Management Server Console and find the SPCC location that you recorded previously. Click on that row.
  - ii. Click Selected-Properties.
  - iii. Click the Connected-To tab. Is the location code valid in the Connected-To tab?
    - ◆ **Yes:** The location code listed in the Connected-To tab is the location code for the SNI. **This ends the procedure.**
    - ◆ **No:** Refer to your cable planning documentation or a cable label, or trace the cable to determine which SNI is connected to this SPCC port.
- c. You do not have a valid location code for either the SNI or the SPCC. Does the reference code that you wrote down in step 2 begin with BB30 or BB40?
- **No:** Go to step 5.
  - **Yes:** The reference code extension for the serviceable event that you wrote down in step 3 indicates the logical location of the port on the SNI that reported the problem.
    - i. Break down the reference code extension. Use [Breaking down a reference code for an SNI](#) as a guide. Write down the frame number, slot number, chip number and port number.
    - ii. Go to the HPSNM Endpoint View on the CSM Management Server and find the row that matches the reference code extension data from the previous step. (The chip number is labeled **Adapter number** in the GUI.) Click on that row.
    - iii. Is the location code valid in the HPSNM Endpoint View?
      - ◆ **Yes:** The location code in the GUI is the location code of the SNI. **This ends the procedure.**
      - ◆ **No:** Do the following:
        1. Click Selected-Properties.
        2. Click the Connected-To tab. Is the location code valid in the Connected-To tab?
          - **Yes:** The location code listed in the Connected-To tab is the location code for the SPCC to which the SNI is connected. **This ends the procedure.**
          - **No:** Determine the SPCC to which the SNI is connected.
            - a. Write down the frame and slot of this SPCC. This frame and slot indicate the location of the switch planar to which the SPCC is connected.
            - b. The SPCC card number (Cx) in the location code should be valid. Use this to find the specific SPCC card that is plugged into the switch planar that you identified in the previous

- step.
- iv. Use your cable planning documentation or a cable label, or trace the cable to determine which SNI is connected to this SPCC port. **This ends the procedure.**
5. Review the information in the FRU list. The Serviceable Event lists one SNI FRU and no SPCC FRU.

**Note:** The frame and slot in the Serviceable Event Text that you recorded in step 3 indicates where to locate the server that contains the SNI.

- a. Break down the reference code extension. Use [Breaking down a reference code for an SNI](#) as a guide. Write down the frame number, slot number, chip number and port number.
- b. Go to the HPSNM Endpoint View on the CSM Management Server and find the row that matches the reference code extension data from the previous step. (The chip number is labeled **Adapter number** in the GUI.) Click on that row.
- c. Click Selected-Properties.
- d. Is the location code valid in the Selected-Properties panel?
  - ◊ **Yes:** The location code listed in the Selected-Properties panel is the location code for the SNI. **This ends the procedure.**
  - ◊ **No:** Does the server in the specified frame and slot contain more than one SNI card?
    - **No:** Only one SNI card is in the server. The location code listed in the Selected-Properties panel is the location code for SNI. **This ends the procedure.**
    - **Yes:** More than one SNI card is in the server. Call your next level of support to help find the correct SNI. **This ends the procedure.**

**Parent topic:** [Symbolic FRUs](#)

#### Breaking down a reference code for an SNI

The following table shows how to break down a sample reference code for a switch network interface (SNI): 0000000040512330. The data for this reference code are frame 4, slot 5, chip 3, port 0.

Table 1. Breaking down SNI reference code 0000000040512330

| 5 chars    | 1 char  | 3 chars      | 2 chars     | 2 chars  | 1 char | 1 char | 1 char |
|------------|---------|--------------|-------------|----------|--------|--------|--------|
| Reserved=0 | Network | Frame number | Slot number | Reserved | Card   | Chip   | Port   |
| 00000      | 0       | 004          | 05          | 12       | 3      | 3      | 0      |

**Before you proceed**

#### Notes:

1. Before you replace the SNI, make sure that you run diagnostics.
2. Try to verify the presence of a flashing LED on the SNI card that you are planning to service. The lack of a flashing LED is not a positive indicator that this is not the correct switch.
3. You can get the part number by looking on the part itself, then cross-referencing that number to the Parts Catalog section of the [45H/W4 Switch Planning, Installation, and Service for POWER5 technology based servers](#) manual. The part number should be for a 1-link SNI.



## HPSASNI

This procedure refers to a high performance switch (HPS) switch network interface (SNI).

You might find this FRU listed in the *Part number* field in the FRU list in a Serviceable Event Details panel. You need to follow this procedure only after you isolate the cause of the serviceable event to an HPS SNI. Two reasons occur for a Symbolic FRU to be displayed instead of a part number:

- The Vital Product Data (VPD) is unavailable, so the part number is unknown.
- The location code for the SNI is not fully known. In this case, the location code includes number sign characters (#) as placeholders. (for example, U####.###.#####-P#-C#).

Valid SNI location codes do not include any number sign characters. When you have a valid SNI code, do the following:

1. Determine in which type of server this SNI is populated.
  - ◆ F servers, use a 2-port SNI
  - ◆ For ESCALA PL 3250R or ESCALA PL 6450R servers, use a 1-port SNI
2. Look up the appropriate SNI part number in the Parts Catalog section of the [45H/W4 Switch Planning, Installation, and Service for POWER5 technology based servers](#) manual.

When the SNI location code is not valid or is not fully known, you need to determine both the location of the SNI and the part number. To help you determine the location of the SNI, you must use either the other side of the cable or the provided frame and slot location.

The basic flow of the following procedure consists of these actions:

1. Write down specific information about the frame, slot, reference code, and reference code extension.
2. Determine the location of the SNI.
3. Verify that you have identified the correct part.
4. Write down the part number.

**Note:** After you complete this procedure but before you continue with your service action, make sure to read the notes in [Before you proceed](#).

To perform this procedure, complete the following steps:

1. Record the frame and slot information from the text in the Serviceable Event Details panel.
2. Record the reference code for the Serviceable Event.
3. Record the reference code extension for the Serviceable Event.
4. Review the information in the FRU list. Does the Serviceable Event list an SNI FRU and a switch port connection card (SPCC) FRU?
  - ◆ **No:** Go to step 5.
  - ◆ **Yes:** Determine if you have a valid location code for the SPCC.
    - a. Do you have a valid location code for the SPCC?
      - **No:** Go to step 4.b.
      - **Yes:** Do the following:
        - i. Record the location of the SPCC that has a valid location.
        - ii. Go to the HPSNM Switch Topology View on the CSM Management Server Console, find the SPCC location that you wrote down from the previous step, and click the SPCC location.
        - iii. Click Selected-Properties.
        - iv. Click the Connected-To tab.

- v. Is the location code valid in the Connected-To tab?
  - ◆ **Yes:** The location code in the Connect-To tab is the location code for the SNI. **This ends the procedure.**
  - ◆ **No:** Refer to your cable planning documentation or a cable label to determine which SNI is connected to this SPCC port. **This ends the procedure.**
- b. You do not have a valid location code for either the SNI or the SPCC. Does the reference code that you wrote down in step 2 begin with BB10, BB20, or BB50?
  - **No:** Go to step 4.c.
  - **Yes:** The frame and slot in the Serviceable Event Text indicate the location of the switch. Do the following

**Note:** The SPCC card number (Cx) in the location code of the SPCC should be valid.

- i. Go to the HPSNM Switch Topology View on the CSM Management Server Console and find the SPCC location that you recorded previously. Click on that row.
- ii. Click Selected-Properties.
- iii. Click the Connected-To tab. Is the location code valid in the Connected-To tab?
  - ◆ **Yes:** The location code listed in the Connected-To tab is the location code for the SNI. **This ends the procedure.**
  - ◆ **No:** Refer to your cable planning documentation or a cable label, or trace the cable to determine which SNI is connected to this SPCC port.
- c. You do not have a valid location code for either the SNI or the SPCC. Does the reference code that you wrote down in step 2 begin with BB30 or BB40?
  - **No:** Go to step 5.
  - **Yes:** The reference code extension for the serviceable event that you wrote down in step 3 indicates the logical location of the port on the SNI that reported the problem.
    - i. Break down the reference code extension. Use [Breaking down a reference code for an SNI](#) as a guide. Write down the frame number, slot number, chip number and port number.
    - ii. Go to the HPSNM Endpoint (The chip number is labeled **Adapter number** in the GUI.) View on the CSM Management Server and find the row that matches the reference code extension data from the previous step. Click on that row.
    - iii. Is the location code valid in the HPSNM Endpoint View?
      - ◆ **Yes:** The location code in the GUI is the location code of the SNI. **This ends the procedure.**
      - ◆ **No:** Do the following:
        1. Click Selected-Properties
        2. Click the Connected-To tab. Is the location code valid in the Connected-To tab?
          - **Yes:** The location code listed in the Connected-To tab is the location code for the SPCC to which the SNI is connected. Continue with step 4.c.iv.
          - **No:** Do the following:
            - a. Write down the frame and slot of this SPCC. This frame and slot indicate the location of the switch planar to which the SPCC is connected.
            - b. The SPCC card number (Cx) in the location code should be valid. Use this to find the specific SPCC card that is plugged into the switch planar that you identified in the previous step.
            - c. Continue with step 4.c.iv.

- iv. Use your cable planning documentation or a cable label, or trace the cable to determine which SNI is connected to this SPCC port. **This ends the procedure.**
- 5. Review the information in the FRU list. The Serviceable Event lists one SNI FRU and no SPCC FRU.

**Note:** The frame and slot in the Serviceable Event Text that you recorded in step 3 indicates where to locate the server that contains the SNI.

- a. Break down the reference code extension. Use [Breaking down a reference code for an SNI](#) as a guide. Write down the frame number, slot number, chip number and port number.
- b. Go to the HPSNM Endpoint View on the CSM Management Server and find the row that matches the reference code extension data from the previous step. (The chip number is labeled Adapter number in the GUI.) Click on that row.
- c. Click Selected-Properties.
- d. Is the location code valid in the HPSNM Endpoint View?
  - ◊ **Yes:** The location code listed in the HPSNM Endpoint View is the location code for the SNI. **This ends the procedure.**
  - ◊ **No:** Does the server in the specified frame and slot contain more than one SNI card?
    - **No:** Only one SNI card is in the server. The location code listed in the HPSNM Endpoint View is the location code for SNI. **This ends the procedure.**
    - **Yes:** More than one SNI card is in the server. Call your next level of support to help find the correct SNI. **This ends the procedure.**

**Parent topic:** [Symbolic FRUs](#)

**Breaking down a reference code for an SNI**

The following table shows how to break down a sample reference code for a switch network interface (SNI): 0000000040512330. The data for this reference code are frame 4, slot 5, chip 3, port 0.

Table 1. Breaking down SNI reference code 0000000040512330

| 5 chars    | 1 char  | 3 chars      | 2 chars     | 2 chars  | 1 char | 1 char | 1 char |
|------------|---------|--------------|-------------|----------|--------|--------|--------|
| Reserved=0 | Network | Frame number | Slot number | Reserved | Card   | Chip   | Port   |
| 00000      | 0       | 004          | 05          | 12       | 3      | 3      | 0      |

**Before you proceed**

**Notes:**

1. Before you replace the SNI, make sure that you run diagnostics.
2. Try to verify the presence of a flashing LED on the SNI card that you are planning to service. The lack of a flashing LED is not a positive indicator that this is not the correct switch.
3. You can get the part number by looking on the part itself, then cross-referencing that number to the Parts Catalog section of the [45H/W4 Switch Planning, Installation, and Service for POWER5 technology based servers](#) manual.

## HPSCCAB

This procedure refers to a high performance switch (HPS) network cable. HPS network cables are fiber or copper and are available in several lengths.

To determine the type and precise length of an HPS cable, perform the following:

1. Examine the label on the cable.
2. Write down the cable part number.
3. To find the cable part number, refer to the Parts Catalog section of the [45H/W4 Switch Planning, Installation, and Service for POWER5 technology based servers](#) manual.

**This ends the procedure.**

For more information and for remove and replace instructions, refer to the [45H/W4 Switch Planning, Installation, and Service for POWER5 technology based servers](#) manual.

**Parent topic:** [Symbolic FRUs](#)

---

## HPSCCOP

This procedure refers to a copper cable used in the high performance switch (HPS) network. This type of copper cable is available in several lengths.

To determine the precise length of this cable, perform the following:

1. Examine the label on the cable.
2. Write down the cable part number.
3. To find the cable part number, refer to the Parts Catalog section of the [45H/W4 Switch Planning, Installation, and Service for POWER5 technology based servers](#) manual.

**This ends the procedure.**

For more information and for remove and replace instructions, refer to the [45H/W4 Switch Planning, Installation, and Service for POWER5 technology based servers](#) manual.

**Parent topic:** [Symbolic FRUs](#)

---

## HPSCFIB

This procedure refers to a fiber cable used in the high performance switch (HPS) network.

This type of fiber cable is available in several lengths. To determine the precise length of this cable, perform the following:

1. Examine the label on the cable.
2. Write down the cable part number.
3. To find the cable part number, refer to the Parts Catalog section of the [45H/W4 Switch Planning, Installation, and Service for POWER5 technology based servers](#) manual.

### This ends the procedure.

For more information and for remove and replace instructions, refer to the [45H/W4 Switch Planning, Installation, and Service for POWER5 technology based servers](#) manual.

Parent topic: [Symbolic FRUs](#)

---

## HPSSPCC

This procedure refers to a high performance switch (HPS) switch port connection card (SPCC).

You might find this FRU listed in the *Part number* field in the FRU list in a Serviceable Event Details panel. You need to follow this procedure only after you isolate the cause of the serviceable event to an HPS SPCC. Two reasons occur for a Symbolic FRU to be displayed instead of a part number:

- The Vital Product Data (VPD) is unavailable, so the part number is unknown.
- The location code for the SPCC is not fully known. In this case, the location code includes number sign characters (#) as placeholders. (for example, U#####.###.#####-P1-C5).

**Note:** The card number (Cx) always should be provided in the location code.

Valid SPCC location codes do not include any number sign characters. When you have a valid SPCC code, do the following:

1. Determine if this SPCC is for fiber cables or copper cables.
2. Look up the appropriate SPCC part number in the Parts Catalog section of the [45H/W4 Switch Planning, Installation, and Service for POWER5 technology based servers](#) manual.

When the SPCC location code is not valid or is not fully known, you need to determine both the location of the SPCC and the part number. To help you determine the location of the SPCC, you must use either the other side of the cable or the provided frame and slot location. You then use the card number to find the card.

The basic flow of the following procedure consists of these actions:

1. Write down specific information about the frame, slot, reference code, and reference code extension.
2. Identify the switch planar into which the SPCC is plugged.
3. Determine which card is the correct SPCC in the switch planar.
4. Verify that you have identified the correct part.
5. Write down the part number.

**Note:** After you complete this procedure but before you continue with your service action, make sure to read the notes in [Before you proceed](#).

To perform this procedure, complete the following steps:

1. Record the frame and slot information from the text in the Serviceable Event Details panel.
2. Record the reference code for the Serviceable Event.
3. Record the reference code extension for the Serviceable Event.
4. Review the information in the FRU list. Does the Serviceable Event list two SPCC FRUs?
  - ◆ **No:** Go to step 5.
  - ◆ **Yes:** Determine if you have a valid location code for the other switch planar.
    - a. Do you have a valid location code for the other SPCC?
      - **No:** Go to step 4.b.
      - **Yes:** Do the following:
        - i. Record the location of the SPCC that has a valid location.
        - ii. Go to the HPSNM Switch Topology View on the CSM Management Server Console, find the SPCC location that you wrote down from the previous step, and click the SPCC location.
        - iii. Click Selected-Properties.
        - iv. Click the Connected-To tab.
        - v. Is the location code valid in the Connected-To tab?
          - ◆ **Yes:** The location code in the Connected-To tab is the location code for the SPCC. **This ends the procedure.**
          - ◆ **No:** Continue with the following steps:
            1. Write down the frame and slot of the port on the other side of the cable. This frame and slot indicate the location of the switch planar into which the SPCC is plugged.
            2. Continue with step 7.
  - b. You do not have a valid location code for either SPCC. Is this the first SPCC in the FRU list?
    - **No:** Go to step 4.c.
    - **Yes:** The frame and slot information in the Serviceable Event text that you wrote down in step 1 indicates the location of the switch into which the SPCC is plugged. Continue with step 7.
  - c. You do not have a valid location code for either SPCC. This is the second switch in the FRU list. Do the following:

**Note:** The reference code extension for the serviceable event that you wrote down in step 3 indicates the location of the port on the other switch that reported the problem.

- i. Break down the reference code extension. Use [Breaking down a reference code for a switch](#) as a guide. Write down the frame number, slot number, chip number and port number.
    - ii. Go to the HPSNM Switch Topology View on the CSM Management Server and find the row that matches the reference code extension data from the previous step. Click on that row.
    - iii. Click Selected-Properties.
    - iv. Click the Connected-To tab. Is the location code valid in the Connected-To tab?
      - **Yes:** The location code listed in the Connected-To tab is the location code for the SPCC. **This ends the procedure.**
      - **No:** Write down the frame and slot of the port on the other side of the cable. This frame and slot indicate the location of the switch planar into which the SPCC is plugged. Continue with step 7.
5. Review the information in the FRU list. Does the Serviceable Event list one SPCC FRU and a switch network interface (SNI) card FRU?
    - ◆ **No:** Go to step 6.
    - ◆ **Yes:** Check the SNI location code.
      - a. Does the SNI have a valid location code?
        - **Yes:** Do the following:
          - i. Write down the location code for the SNI.

- ii. Go to the HPSNM End-point View on the CSM Management Server and find the row that matches the SNI location code that you just wrote down. Click on that row.
  - iii. Click Selected-Properties.
  - iv. Click the Connected-To tab. Is the location code valid in the Connected-To tab?
    - ◆ **Yes:** The location code listed in the Connected-To tab is the location code for the SPCC. **This ends the procedure.**
    - ◆ **No:** Write down the frame and slot of the port on the other side of the cable. This frame and slot indicate the location of the switch planar into which the SPCC is plugged. Continue with step 7.
- **No:** Look at the beginning characters of the reference code that you wrote down step 2.

For reference codes that begin with BB10, BB20, or BB50: The frame and slot in the Serviceable Event Text indicate the location of the switch planar. Continue with step 7.

For reference code that begin with BB30 or BB40: Do the following:

- i. Break down the reference code extension. Use [Breaking down a reference code for an SNI](#) as a guide. Write down the frame number, slot number, chip number, and port number.
  - ii. Go to the HPSNM Endpoint View on the CSM Management Server and find the row that matches the reference code extension data from the previous step. (The chip number is labeled **Adapter number** in the GUI.) Click on that row.
  - iii. Click Selected-Properties.
  - iv. Click the Connected-To tab. Is the location code valid in the Connected-To tab?
    - ◆ **Yes:** The location code listed in the Connected-To tab is the location code for the SPCC. **This ends the procedure.**
    - ◆ **No:** Write down the frame and slot of the port on the other side of the cable. This frame and slot indicate the location of the switch planar into which the SPCC is plugged. Continue with step 7.
6. Review the information in the FRU list. The Serviceable Event lists only one SPCC FRU and does not include an SNI FRU.

The frame and slot in the Serviceable Event Text indicate where to locate the switch planar. **This ends the procedure.**

**Note:** You can double check this by going to the HPSNM Switch Topology View and finding the switch for the indicated frame and slot. Expand the ports and look to see if a valid location code exists for any of the ports. If you see a valid location code, drop the characters "-Cx-Ty" from the location code, then use that as the location code for the switch planar.

7. After you identify the switch planar into which the SPCC plugs, you can identify the SPCC. The card number (Cx) in the location code for the SPCC in question indicates which SPCC is plugged into the switch planar.

**Note:** It is possible that by the time you reach this step, you have found the entire location code for the SPCC.

**This ends the procedure.**

**Parent topic:** [Symbolic FRUs](#)**Breaking down a reference code for a switch**

The following table shows how to break down a sample reference code for a switch: 0000000040303172. The data for this reference code are frame 4, slot 3, chip 7, port 2.

Table 1. Breaking down switch reference code 0000000040303172

| 5 chars    | 1 char  | 3 chars      | 2 chars     | 2 chars  | 1 char | 1 char | 1 char |
|------------|---------|--------------|-------------|----------|--------|--------|--------|
| Reserved=0 | Network | Frame number | Slot number | Reserved | Card   | Chip   | Port   |
| 00000      | 0       | 004          | 03          | 03       | 1      | 7      | 2      |

**Breaking down a reference code for an SNI**

The following table shows how to break down a sample reference code for a switch network interface (SNI): 0000000040512330. The data for this reference code are frame 4, slot 5, chip 3, port 0.

Table 2. Breaking down SNI reference code 0000000040512330

| 5 chars    | 1 char  | 3 chars      | 2 chars     | 2 chars  | 1 char | 1 char | 1 char |
|------------|---------|--------------|-------------|----------|--------|--------|--------|
| Reserved=0 | Network | Frame number | Slot number | Reserved | Card   | Chip   | Port   |
| 00000      | 0       | 004          | 05          | 12       | 3      | 3      | 0      |

**Before you proceed****Notes:**

1. Before you replace the switch planar, make sure that you run diagnostics.
2. If an SPCC appears in the FRU list, try to verify that presences of a flashing LED on the SPCC card in the same enclosure as the switch planar that you are going to service. The lack of a flashing LED is not a positive indicator that this is not the correct switch.
3. You can get the part number by looking on the part itself, then cross-referencing that number to the Parts Catalog section of the [45H/W4 Switch Planning, Installation, and Service for POWER5 technology based servers](#) manual.



## HPSSSW

This procedure refers to a high performance switch (HPS) planar.

You might find this FRU listed in the *Part number* field in the FRU list in a Serviceable Event Details panel. You need to follow this procedure only after you isolate the cause of the serviceable event to a switch planar. Two reasons occur for a Symbolic FRU to be displayed instead of a part number:

- The Vital Product Data (VPD) is unavailable, so the part number is unknown.
- The location code for the switch planar is not fully known. In this case, the location code includes number sign characters (#) as placeholders. (for example, U####.###.#####-P1).

Valid switch planar location codes do not include any number sign characters. When you have a valid switch planar code, look up the switch planar part number in the Parts Catalog section of the [45H/W4 Switch Planning, Installation, and Service for POWER5 technology based servers](#) manual.

When the switch planar location code is not valid or is not fully known, you need to determine the location of the switch planar. To help you determine the location of the switch planar, you must use either the other side of the cable or the provided frame and slot location.

The basic flow of the following procedure consists of these actions:

1. Write down specific information about the frame, slot, reference code, and reference code extension.
2. Determine the location code for the switch planar.
3. Verify that you have identified the correct part.
4. Write down the part number.

**Note:** After you complete this procedure but before you continue with your service action, make sure to read the notes in [Before you proceed](#).

To perform this procedure, complete the following steps:

1. Record the frame and slot information from the text in the Serviceable Event Details panel.
2. Record the reference code for the Serviceable Event.
3. Record the reference code extension for the Serviceable Event.
4. Review the information in the FRU list. Does the Serviceable Event list two switch planar FRUs?
  - ◆ **No:** Go to step 5.
  - ◆ **Yes:** Determine if you have a valid location code for the other switch planar.
    - a. Do you have a valid location code for the other switch planar?
      - **No:** Go to step 4.b.
      - **Yes:** Do the following:
        - i. Find the SPCC that corresponds to the switch planar that has the valid location code. The SPCC has the same unit location as the switch planar: U7045.SW4.serial number. Record the location of the switch port connection card.
        - ii. Go to the HPSNM Switch Topology View on the CSM Management Server Console, find the SPCC location that you wrote down from the previous step, and click the SPCC location.
        - iii. Click Selected-Properties.
        - iv. Click the Connected-To tab.
        - v. Write down the frame and slot of the port on the other side of the cable, which indicate the location of the switch planar. **This ends the procedure.**
    - b. You do not have a valid location code for either switch planar. Is this the first switch in the FRU list?
      - **No:** Go to step 4.c.
      - **Yes:** The frame and slot information in the Serviceable Event text that you wrote down in step 1 indicates the location of the switch you are trying to find.

**This ends the procedure.**

- c. You do not have a valid location code for either switch planar. This is the second switch in the FRU list. Do the following:

**Note:** The reference code extension for the serviceable event that you wrote down in step 3 indicates the location of the port on the other switch that reported the problem.

- i. Break down the reference code extension. Use [Breaking down a reference code for a switch](#) as a guide. Write down the frame number, slot number, chip number and port number.
  - ii. Go to the HPSNM Switch Topology View on the CSM Management Server and find the row that matches the reference code extension data from the previous step. Click on that row.
  - iii. Click Selected-Properties.
  - iv. Click the Connected-To tab. Is the location code valid in the Connected-To tab?
    - **Yes:** Drop the characters "-Cx-Ty" from the location code in the Connected-To tab, then use that location code for the switch planar. **This ends the procedure.**
    - **No:** Write down the frame and slot of the port on the other side of the cable. This frame and slot indicate the location of the switch planar. **This ends the procedure.**
5. Review the information in the FRU list. Does the Serviceable Event list one switch planar FRU and a switch network interface (SNI) card FRU?
- ◆ **No:** Go to step 6.
  - ◆ **Yes:** Check the SNI location code.
    - a. Does the SNI have a valid location code?
      - **Yes:** Do the following:
        - i. Write down the location code for the SNI.
        - ii. Go to the HPSNM End-point View on the CSM Management Server and find the row that matches the SNI location code that you just wrote down. Click on that row.
        - iii. Click Selected-Properties.
        - iv. Click the Connected-To tab. Is the location code valid in the Connected-To tab?
          - ◆ **Yes:** Drop the characters "-Cx-Ty" from the location code in the Connected-To tab, then use that location code for the switch planar. **This ends the procedure.**
          - ◆ **No:** Write down the frame and slot of the port on the other side of the cable, which indicate the location of the switch planar. **This ends the procedure.**
      - **No:** Look at the beginning characters of the reference code that you wrote down step 2.

For reference codes that begin with BB10, BB20, or BB50: The frame and slot in the Serviceable Event Text indicate the location of the switch planar. **This ends the procedure.**

For reference code that begin with BB30 or BB40: Do the following:

- i. Break down the reference code extension. Use [Breaking down a reference code for an SNI](#) as a guide. Write down the frame number, slot number, chip number, and port number.
- ii. Go to the HPSNM Endpoint View on the CSM Management Server and find the row that matches the reference code extension data from the previous step. (The chip number is labeled **Adapter number** in the GUI.) Click on that row.
- iii. Click Selected-Properties.
- iv. Click the Connected-To tab. Is the location code valid in the Connected-To tab?
  - ◆ **Yes:** Drop the characters "-Cx-Ty" from the location code in the Connected-To tab, then use that location code for the switch planar. **This ends the procedure.**

- ◆ **No:** Write down the frame and slot of the port on the other side of the cable. This frame and slot indicate the location of the switch planar. **This ends the procedure.**

6. Review the information in the FRU list. The Serviceable Event lists only one switch planar FRU and does not include an SNI FRU.

The frame and slot in the Serviceable Event Text indicate where to locate the switch planar. **This ends the procedure.**

**Note:** You can double check this by going to the HPSNM Switch Topology View and finding the switch for the indicated frame and slot. Expand the ports and look to see if a valid location code exists for any of the ports. If you see a valid location code, drop the characters "-Cx-Ty" from the location code, then use that as the location code for the switch planar.

**Parent topic:** [Symbolic FRUs](#)

#### Breaking down a reference code for a switch

The following table shows how to break down a sample reference code for a switch: 0000000040303172. The data for this reference code are frame 4, slot 3, chip 7, port 2.

Table 1. Breaking down switch reference code 0000000040303172

| 5 chars    | 1 char  | 3 chars      | 2 chars     | 2 chars  | 1 char | 1 char | 1 char |
|------------|---------|--------------|-------------|----------|--------|--------|--------|
| Reserved=0 | Network | Frame number | Slot number | Reserved | Card   | Chip   | Port   |
| 00000      | 0       | 004          | 03          | 03       | 1      | 7      | 2      |

#### Breaking down a reference code for an SNI

The following table shows how to break down a sample reference code for a switch network interface (SNI): 0000000040512330. The data for this reference code are frame 4, slot 5, chip 3, port 0.

Table 2. Breaking down SNI reference code 0000000040512330

| 5 chars    | 1 char  | 3 chars      | 2 chars     | 2 chars  | 1 char | 1 char | 1 char |
|------------|---------|--------------|-------------|----------|--------|--------|--------|
| Reserved=0 | Network | Frame number | Slot number | Reserved | Card   | Chip   | Port   |
| 00000      | 0       | 004          | 05          | 12       | 3      | 3      | 0      |

**Before you proceed**

**Notes:**

1. Before you replace the switch planar, make sure that you run diagnostics.
  2. If an SPCC appears in the FRU list, try to verify that presences of a flashing LED on the SPCC card in the same enclosure as the switch planar that you are going to service. The lack of a flashing LED is not a positive indicator that this is not the correct switch.
  3. You can get the part number by looking on the part itself, then cross-referencing that number to the Parts Catalog section of the [45H/W4 Switch Planning, Installation, and Service for POWER5 technology based servers](#) manual.
- 

## HSLH

This is a hybrid HSL/RIO to HSL2/RIO-G copper cable where one end has an HSL/RIO yellow connector and the other end has an HSL2/RIO-G black connector.

Diagnostic code cannot determine the length of the cable. Diagnostic code will attempt to determine the location codes of cable ports at each end of the cable. Go to [HSL\\_LNK](#) and follow the appropriate instructions.

**This ends the procedure.**

**Parent topic:** [Symbolic FRUs](#)

---

## HSLH\_xx

This is a hybrid HSL/RIO to HSL2/RIO-G copper cable where one end has an HSL/RIO yellow connector and the other end has an HSL2/RIO-G black connector.

The "xx" value indicates the length of the cable in meters. Go to [HSL\\_LNK](#) and follow the appropriate instructions.

**This ends the procedure.**

**Parent topic:** [Symbolic FRUs](#)

---

## HSLH\_06

This is a hybrid HSL/RIO to HSL2/RIO-G copper cable where one end has an HSL/RIO yellow connector and the other end has an HSL2/RIO-G black connector.

The "06" value indicates the length of the cable is 6 meters. Go to [HSL\\_LNK](#) and follow the appropriate instructions.

**This ends the procedure.**

**Parent topic:** [Symbolic FRUs](#)

---

## HSLH\_15

This is a hybrid HSL/RIO to HSL2/RIO-G copper cable where one end has an HSL/RIO yellow connector and the other end has an HSL2/RIO-G black connector.

The "15" value indicates the length of the cable is 15 meters. Go to [HSL\\_LNK](#) and follow the appropriate instructions.

**This ends the procedure.**

Parent topic: [Symbolic FRUs](#)

---

## HSL\_I

This is an HSL/RIO interposer card for copper HSL2/RIO-G (black) connections or optical HSL/RIO connections.

Diagnostic code cannot determine the type of interposer card. Go to [HSL\\_LNK](#) and follow the appropriate instructions.

**This ends the procedure.**

Parent topic: [Symbolic FRUs](#)

---

## HSL\_Ix

This is an HSL/RIO interposer card for copper HSL2/RIO-G (black) connections or optical HSL/RIO connections.

The "x" value indicates the type of interposer card. Go to [HSL\\_LNK](#) and follow the appropriate instructions.

**This ends the procedure.**

Parent topic: [Symbolic FRUs](#)

---

## HSL\_I2

The failing item is an HSL2/RIO-G interposer card on machine type 9406 model 825.

This interposer card is for copper HSL2/RIO-G cable connectors (black) on the system unit planar in location C08 or C09. Diagnostic code will attempt to include the card's location with the FRU in the serviceable event view. Go to [HSL\\_LNK](#) and follow the appropriate instructions.

**This ends the procedure.**

Parent topic: [Symbolic FRUs](#)

---

## HSL\_I3

The failing item is an HSL/RIO interposer card on machine type 9406 model 825.

This interposer card is for optical HSL/RIO cable connectors on the system unit planar in location C08 or C09. Diagnostic code will attempt to include the card's location with the FRU in the serviceable event view. Go to [HSL\\_LNK](#) and follow the appropriate instructions.

**This ends the procedure.**

Parent topic: [Symbolic FRUs](#)

---

## HSL\_I4

The failing item is an HSL2/RIO-G interposer card on a 406/1D expansion unit.

This interposer card is for copper HSL2/RIO-G cable connectors (black) on the I/O unit planar in location -P1(riser) or -P2(riser). Diagnostic code will attempt to include the card's location with the FRU in the serviceable event view. Go to [HSL\\_LNK](#) and follow the appropriate instructions.

**This ends the procedure.**

## HSL\_LNK

When a RIO cable is disconnected, it may result in a lost connection between the units even after the cable is reconnected.

**Attention:** To fix this problem, you need to cycle power on the unit with the locked RIO connection (see [Powering on and powering off an I/O expansion unit](#) below).

**Note:** If question marks (???) appear at the end of the location code, then the port could not be determined. Use the location code associated with the other end of the cable. If question marks appear for both port locations, use the isolation procedures suggested in the Description/Action column of the reference code table for this SRC.

1. Choose from the following:

- ◆ If you were sent to this procedure from another symbolic FRU, locate that FRU in [Table 1](#) to see the description of the RIO FRU. Then continue with the next step for more information about the FRU.
- ◆ If you are working with this symbolic FRU in the FRU list, the failing component is an RIO connection. Diagnostic code could not determine what kind of hardware was involved. The RIO hardware can be any of the following:
  - ◇ Cable
  - ◇ Embedded RIO link in a FRU (a planar, for example)
  - ◇ RIO interposer card

The RIO link is on or between the other FRU or FRUs listed for the reference code. Continue with the next step.

Table 1. RIO symbolic FRUs

| RIO FRU | Description                                                                                                                                                                                                                                                                                                                                  |
|---------|----------------------------------------------------------------------------------------------------------------------------------------------------------------------------------------------------------------------------------------------------------------------------------------------------------------------------------------------|
| HSL_OPT | This is an optical RIO cable.<br><br>When exchanging optical RIO cables, use the optical cleaning kit and procedures. See symbolic FRU <a href="#">OPT_CLN</a> for details.<br><br>If an interposer card is called for, be sure the interposer type matches the cable type (optical or copper).                                              |
| HSL1    | There is a standard copper RIO cable at both ends (yellow connectors).                                                                                                                                                                                                                                                                       |
| HSL1_UN | There is a standard copper RIO cable (yellow connector) at the detecting end, and an unknown connector type at the other end.                                                                                                                                                                                                                |
| HSL2    | There is a copper HSL2/RIO-G cable at both ends (black connectors), but the length of the cable could not be sensed.                                                                                                                                                                                                                         |
| HSL2_xx | There is a copper HSL2/RIO-G cable at both ends (black connectors). Use the xx value to determine the cable length from this list: <ul style="list-style-type: none"> <li>◆ HSL2_01 = 1 meter HSL2 cable</li> <li>◆ HSL2_03 = 3 meter HSL2 cable</li> <li>◆ HSL2_08 = 8 meter HSL2 cable</li> <li>◆ HSL2_10 = 10 meter HSL2 cable</li> </ul> |

|         |                                                                                                                                                                                                                                                                                                                                                                                                                                                                                                                                                                                                                                                                                                       |
|---------|-------------------------------------------------------------------------------------------------------------------------------------------------------------------------------------------------------------------------------------------------------------------------------------------------------------------------------------------------------------------------------------------------------------------------------------------------------------------------------------------------------------------------------------------------------------------------------------------------------------------------------------------------------------------------------------------------------|
|         | <ul style="list-style-type: none"> <li>◆ HSL2_15 = 15 meter HSL2 cable</li> <li>◆ HSL2_17 = 1.75 meter HSL2 cable</li> <li>◆ HSL2_25 = 2.5 meter HSL2 cable</li> </ul>                                                                                                                                                                                                                                                                                                                                                                                                                                                                                                                                |
| HSLH    | There is a hybrid RIO to HSL2/RIO-G cable (yellow connector at one end and black connector at the other end), but the length of the cable could not be sensed.                                                                                                                                                                                                                                                                                                                                                                                                                                                                                                                                        |
| HSL_IB  | This is an cable (green connectors).                                                                                                                                                                                                                                                                                                                                                                                                                                                                                                                                                                                                                                                                  |
| HSLH_xx | There is a hybrid RIO to HSL2/RIO-G cable (yellow connector at one end and black connector at the other end). Use the xx value to determine the cable length from this list: <ul style="list-style-type: none"> <li>◆ HSLH_06 = 6 meter HSL/RIO to HSL2/RIO-G cable</li> <li>◆ HSLH_15 = 15 meter HSL/RIO to HSL2/RIO-G cable</li> </ul>                                                                                                                                                                                                                                                                                                                                                              |
| HSL_I   | There is a RIO interposer card for HSL/RIO cables (yellow connectors), HSL2/RIO-G cables (black connectors), or optical cables. The interposer card type could not be sensed.                                                                                                                                                                                                                                                                                                                                                                                                                                                                                                                         |
| HSL_Ix  | There is a RIO interposer card for HSL/RIO cables (yellow connectors), HSL2/RIO-G cables (black connectors), or optical cables. Use the x value to determine the interposer card type from this list: <ul style="list-style-type: none"> <li>◆ HSL_I2 = Copper HSL2/RIO-G interposer card for HSL2/RIO-G cable connectors (black) in the system unit backplane position C08 or C09 of machine type 9406 model 825.</li> <li>◆ HSL_I3 = Optical HSL/RIO interposer card for optical RIO cables in system unit backplane position C08 or C09 of machine type 9406 model 825.</li> <li>◆ HSL_I4 = HSL2/RIO-G interposer/riser card on a 406/1D I/O unit in location -P1-riser or -P2-(Riser).</li> </ul> |

2. Choose from the following options:
  - ◆ If you are working from the serviceable event view, the location code or FRU description in the view will help determine the actual RIO hardware to exchange. Continue with the next step.
  - ◆ If you are not working from the serviceable event view, or the view does not have a location code or better FRU description, then determine the location code of other FRUs in the FRU list for the error. Then continue with the next step.
3. Use the location code and the information from the preceding table, or other FRUs listed in the FRU list for this error, to determine the machine type, model, or unit feature involved in the error. Use [Table 2](#) to find links to the locations information.

**Note:** If you exchange all of the FRUs in the FRU list, but the problem still exists, contact your next level of support. You may be directed to exchange additional RIO FRUs. [Additional RIO FRUs](#) have more information about RIO FRUs on specific models and I/O units. Use this section when you are directed by your next level of support.

Table 2. Location information

| Machine type, model, or unit feature | Symbolic FRU to search for in the locations information | Link to location information                                                                |
|--------------------------------------|---------------------------------------------------------|---------------------------------------------------------------------------------------------|
| ESCALA PL 250T/R                     | HSL_LNK                                                 | <a href="#">Locations</a> <a href="#">Model ESCALA PL 250T/R</a>                            |
| ESCALA PL 450T/R                     | HSL_LNK                                                 | <a href="#">Locations</a> <a href="#">Model ESCALA PL 450T/R</a>                            |
| ESCALA PL 850R/PL 1650R/R+           | HSL_LNK                                                 | <a href="#">Locations</a> <a href="#">Model ESCALA PL 850R/PL 1650R/R+</a>                  |
| 50/74, 8079-002, 8093-002            | HSL_LNK                                                 | <a href="#">Locations</a> <a href="#">50/74, 8079-002, and 8093-002 expansion I/O units</a> |

Service provider information

|                                   |         |                                                          |
|-----------------------------------|---------|----------------------------------------------------------|
| 50/79                             | HSL_LNK | Locations 50/79 expansion I/O unit                       |
| 50/88, 05/88                      | HSL_LNK | Locations 50/88 and 05/88 expansion I/O units            |
| 50/94, 52/94, 8094-002            | HSL_LNK | Locations 50/94, 52/94, and 8094-002 expansion I/O units |
| 50/95, 05/95                      | HSL_LNK | Locations 50/95 and 05/95 expansion I/O units            |
| Type 1519 external xSeries server | HSL_LNK | See table in card positions for xSeries                  |
| 11D/10, 11D/11, and 57/90         | HSL_LNK | Locations 11D/10 and 11D/11 and 57/90 expansion unit     |
| 406/1D                            | HSL_LNK | Locations 5791, 5794, and 7040-61D expansion units       |

Parent topic: [Symbolic FRUs](#)

**Additional RIO FRUs**

The following are RIO FRUs by model and/or unit type. For the model or unit type you are working on, there may be additional RIO FRUs which were not listed in the FRU list of the error. Under the direction of your next level of support, you can try exchanging the additional FRUs.

1. In the following table, locate the unit type(s) on which you are working. Exchange the indicated RIO loop connections (external or embedded) or RIO interposer card.
2. Did the exchange correct the error?
  - ◆ **Yes:** The FRU you just replaced was the failing item. Go to [Verifying the repair](#).

**This ends the procedure.**

- ◆ **No:** Call your next level of support.

**This ends the procedure.**

Table 3. HSL/RIO cable or connections

| System model or unit type         | RIO cable or connections                                                     | Link to locations information                               |
|-----------------------------------|------------------------------------------------------------------------------|-------------------------------------------------------------|
| 50/74, 8079-002, 8093-002         | External RIO ports on the HSL I/O bridge / RIO adapter card in location C08. | Locations 50/74, 8079-002, and 8093-002 expansion I/O units |
| 50/79                             | External RIO ports on the HSL I/O bridge / RIO adapter card in location C08. | Locations 50/79 expansion I/O unit                          |
| 50/88, 05/88                      | External RIO ports on the HSL I/O bridge / RIO adapter card in location C10. | Locations 50/88 and 05/88 expansion I/O units               |
| 50/94, 8094-002                   | External RIO ports on the HSL I/O bridge / RIO adapter card in location C10. | Locations 50/94, 52/94, and 8094-002 expansion I/O units    |
| 50/95, 05/95                      | External RIO ports on the HSL I/O bridge / RIO adapter card in location C05. | Locations 50/95 and 05/95 expansion I/O units               |
| 52/94                             | External RIO ports on the HSL I/O bridge / RIO adapter card in location C08. | Locations 50/94, 52/94, and 8094-002 expansion I/O units    |
| Type 1519 external xSeries server | External RIO ports on the Integrated xSeries Adapter.                        | See table in card positions for xSeries                     |
| 11D/10, 11D/11, and 57/90         | External RIO ports on the HSL I/O bridge / RIO adapter card in               | Locations 11D/10 and 11D/11 and 57/90 expansion             |



|        | location -P1.1.                                                                                                                                                                                                                                                                                                                                                                                                                      | unit                                               |
|--------|--------------------------------------------------------------------------------------------------------------------------------------------------------------------------------------------------------------------------------------------------------------------------------------------------------------------------------------------------------------------------------------------------------------------------------------|----------------------------------------------------|
| 406/1D | <ul style="list-style-type: none"> <li>◆ External RIO ports on the HSL I/O bridge / RIO adapter interposer card in location -P1-(Riser)</li> <li>◆ Embedded RIO ports in the I/O unit logic planar in position -P1-(Planar)</li> <li>◆ External RIO ports on the HSL I/O bridge / RIO adapter interposer card in location -P2-(Riser)</li> <li>◆ Embedded RIO ports in the I/O unit logic planar in position -P2-(Planar)</li> </ul> | Locations 5791, 5794, and 7040-61D expansion units |

### Powering on and powering off an I/O expansion unit

Follow these steps if you disconnected an RIO cable from an I/O expansion unit, and the RIO link on the unit did not recover when you reconnected the cable:

1. From the Hardware Service Manager screen, select Packaging hardware resources.
2. Select the frame that has just accidentally lost its RIO connection and select Concurrent maintenance. Then press Enter.
3. Select Power off domain.
4. After reconnecting the unit into the RIO loop, select Power on domain.

---

## HSL\_OPT

This is an optical HSL/RIO cable.

When connecting or disconnecting these cables, use the optical cleaning kit described in [OPT\\_CLN](#). Go to [HSL\\_LNK](#) and follow the appropriate instructions.

**This ends the procedure.**

**Parent topic:** [Symbolic FRUs](#)

---

## HSL1

This is a standard copper HSL/RIO cable at both ends.

Diagnostic code cannot determine the length of the cable. Go to [HSL\\_LNK](#) and follow the appropriate instructions.

**This ends the procedure.**

**Parent topic:** [Symbolic FRUs](#)

---

## HSL1\_UN

This is a standard copper HSL/RIO cable at the end where an error was detected.

Diagnostic code cannot determine the length of the cable, or the type of connector at the other end. Go to [HSL\\_LNK](#) and follow the appropriate instructions.

**This ends the procedure.**

Parent topic: [Symbolic FRUs](#)

---

## HSL2

This is an HSL2/RIO-G copper HSL/RIO cable at both ends.

Diagnostic code cannot determine the length of the cable. Go to [HSL\\_LNK](#) and follow the appropriate instructions.

**This ends the procedure.**

Parent topic: [Symbolic FRUs](#)

---

## HSL2\_xx

This is an HSL2/RIO-G copper HSL/RIO cable at both ends.

The xx value indicates the cable length in meters. Go to [HSL\\_LNK](#) and follow the appropriate instructions.

**This ends the procedure.**

Parent topic: [Symbolic FRUs](#)

---

## HSL2\_01

This is an HSL2/RIO-G copper HSL/RIO cable at both ends.

The 01 value indicates the cable is 1 meter long. Go to [HSL\\_LNK](#) and follow the appropriate instructions.

**This ends the procedure.**

Parent topic: [Symbolic FRUs](#)

---

## HSL2\_03

This is an HSL2/RIO-G copper HSL/RIO cable at both ends.

The 03 value indicates the cable is 3 meters long. Go to [HSL\\_LNK](#) and follow the appropriate instructions.

**This ends the procedure.**

Parent topic: [Symbolic FRUs](#)

---

## HSL2\_08

This is an HSL2/RIO-G copper HSL/RIO cable at both ends.

The 08 value indicates the cable is 8 meters long. Go to [HSL\\_LNK](#) and follow the appropriate instructions.

**This ends the procedure.**

Parent topic: [Symbolic FRUs](#)

---

## HSL2\_10

This is an HSL2/RIO-G copper HSL/RIO cable at both ends.

The 10 value indicates the cable is 10 meters long. Go to [HSL\\_LNK](#) and follow the appropriate instructions.

**This ends the procedure.**

Parent topic: [Symbolic FRUs](#)

---

## HSL2\_15

This is an HSL2/RIO-G copper HSL/RIO cable at both ends.

The 15 value indicates the cable is 15 meters long. Go to [HSL\\_LNK](#) and follow the appropriate instructions.

**This ends the procedure.**

Parent topic: [Symbolic FRUs](#)

---

## HSL2\_17

This is an HSL2/RIO-G copper HSL/RIO cable at both ends.

The 17 value indicates that the cable is 1.75 meters long. Go to [HSL\\_LNK](#) and follow the appropriate instructions.

Parent topic: [Symbolic FRUs](#)

---

## HSL2\_25

This is an HSL2/RIO-G copper HSL/RIO cable at both ends.

The 25 value indicates that the cable is 2.5 meters long. Go to [HSL\\_LNK](#) and follow the appropriate instructions.

Parent topic: [Symbolic FRUs](#)

---

## I2CBUS

A fault was detected on the I2C bus.

Choose the model or I/O expansion unit you are working on:

- [Instructions for Models 112/85, ESCALA PL 250R-VL or ESCALA PL 450R-XS, ESCALA PL 250R-L, PL 250R-L+ or PL 450R-VL+, ESCALA PL 250T/R, PL 250T/R+ or PL 450T/R-L+, ESCALA PL 450T/R, PL 450T/R+ or PL 850T/R-L+, ESCALA PL 1650R-L+ , ESCALA PL 850R/PL 1650R/R+,](#)
- [Instructions for 50/95, 05/95, 57/90, 11D/10, 11D/11, and 11D/20 I/O expansion units](#)
- [Instructions for all I/O expansion units except 50/95, 05/95, 57/90, 11D/10, 11D/11, and 11D/20](#)

Parent topic: [Symbolic FRUs](#)

Instructions for Models 112/85, ESCALA PL 250R-VL or ESCALA PL 450R-XS, ESCALA PL 250R-L, PL 250R-L+ or PL 450R-VL+, ESCALA PL 250T/R, PL 250T/R+ or PL 450T/R-L+, ESCALA PL 450T/R, PL 450T/R+ or PL 850T/R-L+, ESCALA PL 1650R-L+, ESCALA PL 850R/PL 1650R/R+, 7/10,

1. Is the reference code 3114?

- ◆ **No:** Continue with the next step.
- ◆ **Yes:** Replace the following (see [Finding part locations](#) for part numbers and a link to the exchange procedure):
  - ◇ For models ESCALA PL 250R-VL or ESCALA PL 450R-XS, ESCALA PL 250R-L, PL 250R-L+ or PL 450R-VL+, ESCALA PL 250T/R, PL 250T/R+ or PL 450T/R-L+, ESCALA PL 450T/R, PL 450T/R+ or PL 850T/R-L+, , replace the system backplane (SYSBKPL).
  - ◇ For models ESCALA PL 1650R-L+ and ESCALA PL 850R/PL 1650R/R+ (4-way), replace the I/O backplane (SYSBKPL).
  - ◇ For models ESCALA PL 1650R-L+ and ESCALA PL 850R/PL 1650R/R+ (8-way through 16-way), verify that the service processor cable is connected and seated properly on all units. If the reference code prevails, replace the following, one at a time, until the problem is resolved:
    - a. service processor cable (see [Locations](#) model ESCALA PL 1650R-L+ and ESCALA PL 850R/PL 1650R/R+)
    - b. service processor (see [Locations](#) model ESCALA PL 1650R-L+ and ESCALA PL 850R/PL 1650R/R+)
    - c. I/O backplane on the failing unit (see [Locations](#) model ESCALA PL 1650R-L+ and ESCALA PL 850R/PL 1650R/R+)
  - ◇ For model 5/75, replace the system I/O backplane (see [Locations](#) model 5/75)
  - ◇ For models ESCALA PL 3250R and ESCALA PL 6450R, replace the FSP card (see [Locations](#) model ESCALA PL 3250R and ESCALA PL 6450R)

**This ends the procedure.**

2. Is the reference code 3109?

- ◆ **No:** Continue with the next FRU in the list. **This ends the procedure.**
- ◆ **Yes:** Replace the PCI backplane (see [Locations](#) model ESCALA PL 250R-L, PL 250R-L+ or PL 450R-VL+ ). **This ends the procedure.**

Instructions for 50/95, 05/95, 57/90, 11D/10, 11D/11, and 11D/20 I/O expansion units

1. Is the reference code 3100, 3104, 3105, 3116, or 3118?

- ◆ **No:** Continue with the next step.
- ◆ **Yes:** Replace the backplane (TWRCARD). See [Finding part locations](#) for part numbers and a link to the exchange procedure. **This ends the procedure.**

2. Is the reference code 3101 or 3115?

- ◆ **No:** Continue with the next step.
- ◆ **Yes:** Replace the following FRUs one at a time (see [Finding part locations](#) for part numbers and a link to the exchange procedure):
  - ◇ Display panel
  - ◇ Backplane (TWRCARD)
  - ◇ Signal cable SIGC01 (connecting the backplane to the display panel). **This ends the procedure.**

3. Is the reference code 3102, 3113, or 3114?

- ◆ **No:** Continue with the next step.
- ◆ **Yes:** Replace the following FRUs one at a time (see [Finding part locations](#) for part numbers and a link to the exchange procedure):
  - ◇ Backplane (TWRCARD)
  - ◇ Signal cable SIGC04 (connecting the SPCN card to the tower card). **This ends the procedure.**

4. Is the reference code 3103 or 3112?

- ◆ **No:** Continue with the next step.
- ◆ **Yes:** Replace the following FRUs one at a time:
  - ◇ Device board (see [Finding part locations](#))
  - ◇ SPCN card (see [TWRCARD](#)). **This ends the procedure.**

5. Is the reference code 3121?

- ◆ **No:** Return to [Start of call procedure](#). **This ends the procedure.**
- ◆ **Yes:** Is this for a FC5790 (7311-D11)?
  - ◇ **No:** Replace device board 1 (see [Finding part locations](#) for part numbers and a link to the exchange procedure). **This ends the procedure.**
  - ◇ **Yes:** Replace the following FRUs (see [Finding part locations](#) for part numbers and a link to the exchange procedure), one at a time, until the problem is resolved:

- Rio-G Riser card
- I/O Planar

**This ends the procedure.**

**Instructions for all I/O expansion units except 50/95, 05/95, 57/90, 11D/10, 11D/11, and 11D/20**

1. Is the reference code 3101, 3105, 3115, or 3116?
  - ◆ **No:** Go to step 3.
  - ◆ **Yes:** Continue with the next step.
2. Are you working on a 50/88 or 05/88?
  - ◆ **No:** Replace the following FRUs (see [Finding part locations](#)):
    - ◇ Control panel NB1
    - ◇ Tower card CB1
    - ◇ Power cable PWR60 (connecting power distribution board PB1 to device board DB3).
    - ◇ Signal cable SIG63 (connecting control panel NB1 to device board DB3). **This ends the procedure.**
  - ◆ **Yes:** Replace the following FRUs (see [Locations](#) 50/88 and 05/88 expansion I/O units):
 

For reference code 3101 or 3115:

    - ◇ Control panel NB1
    - ◇ Tower card CB1

For reference code 3105 or 3116:

    - ◇ Fan controller assembly BB1
    - ◇ Tower card CB1

**This ends the procedure.**
3. Is the reference code 3102?
  - ◆ **No:** Continue with the next step.
  - ◆ **Yes:** Replace the following FRUs one at a time (see [Finding part locations](#)):
    - ◇ HSL I/O bridge C08
    - ◇ Tower card CB1

**This ends the procedure.**
4. Is the reference code 3103?
  - ◆ **No:** Continue with the next step.
  - ◆ **Yes:** Replace the following FRUs one at a time (see [Finding part locations](#)):
 

For 50/88 and 05/88:

    - ◇ Tower card CB1

For 50/74, 50/79, 50/94, and 52/94:

    - ◇ Device board DB1
    - ◇ Device board DB2
    - ◇ Device board DB3
    - ◇ Tower card CB1

**This ends the procedure.**
5. Is the reference code 3104, 3114, or 3118?
  - ◆ **No:** Continue with the next step.
  - ◆ **Yes:** Replace the tower card CB1 (see [Finding part locations](#)). **This ends the procedure.**
6. Is the reference code 3106?
  - ◆ **No:** Continue with the next step.
  - ◆ **Yes:** Replace the network interface controller (NIC) card M41. (see [Finding part locations](#)). **This ends the procedure.**
7. Is the reference code 3110, 3111, or 3112?
  - ◆ **No:** Go to step 11.
  - ◆ **Yes:** Continue with the next step.
8. Is the reference code 3110?
  - ◆ **No:** Continue with the next step.
  - ◆ **Yes:** Replace the following FRUs one at a time (see [Finding part locations](#)):
    - ◇ Device board DB1
    - ◇ Tower card CB1

**This ends the procedure.**
9. Is the reference code 3111?
  - ◆ **No:** Continue with the next step.
  - ◆ **Yes:** Replace the following FRUs one at a time (see [Finding part locations](#)):

- ◇ Device board DB2

- ◇ Tower card CB1

**This ends the procedure.**

10. Is the reference code 3112?

- ◆ **No:** Continue with the next step.

- ◆ **Yes:** Replace the following FRUs one at a time (see [Finding part locations](#)):

- ◇ Device board DB3

- ◇ Tower card CB1

**This ends the procedure.**

11. Is the reference code 3113?

- ◆ **No:** Return to [Start of call procedure](#). **This ends the procedure.**

- ◆ **Yes:** Replace the HSL I/O bridge (see [Finding part locations](#)). **This ends the procedure.**

---

## IDPART

A system unit part is failing.

1. Is the reference code 1xxx 8430, 8431, or 8432?

- ◆ **No:** Continue with the next step.

- ◆ **Yes:** Go to step 4.

2. Is the reference code 1xxx 840D or 840E?

- ◆ **Yes:** Continue with the next step.

- ◆ **No:** Go to step 4.

3. Is the reference code for an xSeries server unit?

- ◆ **No:** Perform [PWR1917](#) for the correct configuration ID. **This ends the procedure.**

- ◆ **Yes:** Exchange the Integrated xSeries Adapter (IXA) (see [Locations](#) [Integrated xSeries adapter card \(IXA\)](#)). **This ends the procedure.**

4. Perform [PWR1917](#) for the correct configuration ID, and then return here and continue with the next step.

5. Is the reference code 1xxx 8430?

- ◆ **No:** Continue with the next step.

- ◆ **Yes:** Verify that the FSP cable is connected and seated correctly. If the reference code prevails, replace the following, one at a time, until the problem is resolved:

- a. Service processor cable (see [Model ESCALA PL 850R/PL 1650R/R+ cables](#) for the part number and then [Remove and replace the model ESCALA PL 850R/PL 1650R/R+ service processor cable](#))

- b. Service processor card (see [Locations](#) [model ESCALA PL 850R/PL 1650R/R+](#))

- c. I/O backplane (see [Locations](#) [model ESCALA PL 850R/PL 1650R/R+](#))

**This ends the procedure.**

6. Is the reference code 1xxx 8431?

- ◆ **No:** Continue with the next step.

- ◆ **Yes:** Replace the following, one at a time, until the problem is resolved:

- a. The service processor cable is not needed for this system configuration

- b. Service processor card (see [Locations](#) [model ESCALA PL 850R/PL 1650R/R+](#))

- c. I/O backplane (see [Locations](#) [model ESCALA PL 850R/PL 1650R/R+](#))

**This ends the procedure.**

7. Is the reference code 1xxx 8432?

- ◆ **No:** The reference code has changed. Return to the [Start of call procedure](#). **This ends the procedure.**

- ◆ **Yes:** Replace the service processor card (see [Locations](#) [model ESCALA PL 850R/PL 1650R/R+](#)). **This ends the procedure.**

Parent topic: [Symbolic FRUs](#)

---

## IOA

You need to determine the field replaceable unit (FRU) part number.

Contact your next level of support.

**This ends the procedure.**

Parent topic: [Symbolic FRUs](#)

## IOACNFG

There is an IOA configuration problem.

Too many communications lines or IOAs are configured using the same IOP. See [Hardware service manager](#) in the [Service functions](#) for information about how to move an IOA to another IOP.

**Parent topic:** [Symbolic FRUs](#)

## IOADPTR

The hardware, firmware, microcode, or device driver of an adapter or card slot detected an error.

The failing component is the adapter in the location specified in the SRC.

1. Are you working from the serviceable event view and is there a card location listed with this FRU?
  - ◆ **Yes:** Use [Table 1](#) to replace the adapter identified by this location code. **This ends the procedure.**
  - ◆ **No:** Determine the location of the adapter by working with the customer or your next level of support. If you cannot determine the location of the failing adapter by using SRC or resource information or the device tree, then determine the adapter type from the SRC, SRC description, failing resources, or error message you are working with. Make a list of all the adapter locations of that type assigned to the partition. Continue with the next step.
2. Have you identified a single FRU location?
  - ◆ **Yes:** Use [Table 1](#) to replace the FRU you have identified. **This ends the procedure.**
  - ◆ **No:** Continue with the next step.
3. Using the location codes you have identified, determine which system unit and expansion units have PCI adapters of this type assigned to the partition you are working with. Starting with the expansion units first, remove all of the PCI adapters of this type from one of the units (use [Table 1](#) to guide you to the correct locations information and removal procedure).

### Attention:

- ◆ Remove the PCI adapters from the system unit only after you have tried all of the expansion units first.
- ◆ Do **not** remove any FRUs with embedded adapters, only FRUs in PCI card slots.

Continue with the next step.

4. Reinstall one of the adapters (use [Table 1](#) to guide you to the correct removal procedure) and power on the unit. Continue with the next step.
5. Does the problem reoccur?
  - ◆ **Yes:** The adapter you just reinstalled is the failing item and needs to be replaced (use [Table 1](#) to guide you to the correct locations information and removal procedure). **This ends the procedure.**
  - ◆ **No:** Continue with the next step.
6. Have you reinstalled all of the adapters on the unit you're currently working with?
  - ◆ **Yes:** Continue with the next step.
  - ◆ **No:** Return to step 4 and reinstall the next adapter on this unit.
7. Are there any units (including the system unit) on which you have not yet removed and reinstalled the PCI adapters?
  - ◆ **No:** Continue with the next step.
  - ◆ **Yes:** Return to step 3 and work with another unit.
8. Go to [Card positions](#) to determine if system unit or any of the expansion units has an embedded adapter of the type you are working with. Is there such an embedded adapter?

- ◆ **No:** The problem may be intermittent. Contact your next level of support. **This ends the procedure.**
- ◆ **Yes:** The FRU with the embedded adapter is the failing item and needs to be replaced. Use [Table 1](#) to exchange the FRU at the location specified in the card position table. Repeat this step for each expansion unit with an embedded adapter assigned to the partition, and then for the system unit. **This ends the procedure.**

Table 1. Failing items for symbolic FRU IOADPTR

| System model, expansion unit, or machine type | Symbolic FRU to locate                                          | FRU location             | Link to locations information                                           |
|-----------------------------------------------|-----------------------------------------------------------------|--------------------------|-------------------------------------------------------------------------|
| ESCALA PL 250T/R                              | PCI IOA card in PCI bridge set 1                                | -P1-C1-P1-C2-P1-C4       | <a href="#">Locations model ESCALA PL 250T/R</a>                        |
|                                               | PCI IOA card in PCI bridge set 2                                | -P1-C3-P1-C5-P1-C6       |                                                                         |
|                                               | Embedded adapters in system backplane, PCI bridge sets 1 and 2  | -P1                      |                                                                         |
| ESCALA PL 450T/R                              | PCI IOA card in PCI bridge set 1                                | -P1-C1-P1-C2             | <a href="#">Locations model ESCALA PL 450T/R</a>                        |
|                                               | PCI IOA card in PCI bridge set 2                                | -P1-C3-P1-C4-P1-C5       |                                                                         |
|                                               | Embedded adapters in system backplane, PCI bridge sets 1 and 2  | -P1                      |                                                                         |
| ESCALA PL 850R/PL 1650R/R+                    | PCI IOA card in PCI bridge set 2                                | -P1-C1-P1-C2             | <a href="#">Locations model ESCALA PL 850R/PL 1650R/R+</a>              |
|                                               | PCI IOA card in PCI bridge set 3                                | -P1-C3-P1-C4-P1-C5-P1-C6 |                                                                         |
|                                               | Embedded adapters in I/O backplane, PCI bridge sets 1, 2, and 3 | -P1                      |                                                                         |
| 50/74, 8079-002, 8093-002                     | PCI IOA in PCI bridge set 1                                     | C01C02C03C04             | <a href="#">Locations 50/74, 8079-002, and 8093-002 expansion units</a> |
|                                               | PCI IOA in PCI bridge set 2                                     | C05C06C07C09C10          |                                                                         |
|                                               | PCI IOA in PCI bridge set 3                                     | C11C12C13C14C15          |                                                                         |
| 50/79                                         | PCI IOA in PCI bridge set 1                                     | C01C02C03C04             | <a href="#">Locations 50/79 expansion unit</a>                          |
|                                               | PCI IOA in PCI bridge set 2                                     | C05C06C07C09C10          |                                                                         |
|                                               | PCI IOA in PCI bridge set 3                                     | C11C12C13C14C15          |                                                                         |
| 50/88, 05/88                                  | PCI IOA in PCI bridge set 1                                     | C01C02C03C04             | <a href="#">Locations 50/88 and 05/88 expansion units</a>               |
|                                               | PCI IOA in PCI bridge set 2                                     | C05C06C07C08C09          |                                                                         |
|                                               | PCI IOA in PCI bridge set 3                                     | C11C12C13C14C15          |                                                                         |
| 50/94, 52/94, 8094-002                        | PCI IOA in PCI bridge set 1                                     | C01C02C03C04             | <a href="#">Locations 50/94, 52/94, and 8094-002 expansion units</a>    |
|                                               | PCI IOA in PCI bridge set 2                                     | C05C06C07C08C09          |                                                                         |
|                                               | PCI IOA in PCI bridge set 3                                     | C11C12C13C14C15          |                                                                         |
| 50/95, 05/95                                  | PCI IOA in PCI bridge set 1                                     | C01C02C03C04             | <a href="#">Locations 50/95 and 05/95 expansion units</a>               |
|                                               | PCI IOA in PCI bridge set 2                                     | C06C07C08                |                                                                         |
| 11D/10, 11D/11, and 57/90                     | PCI IOA in PCI bridge set 1                                     | -P1-I1-P1-I2-P1-I3       | <a href="#">Locations 11D/10, 11D/11, and 57/90</a>                     |
|                                               | PCI IOA in PCI bridge set 2                                     | -P1-I4-P1-I5-P1-I6       |                                                                         |



Service provider information

|                          |                                                                        |                          |                                                                   |
|--------------------------|------------------------------------------------------------------------|--------------------------|-------------------------------------------------------------------|
|                          |                                                                        |                          | <a href="#">expansion units</a>                                   |
| 11D/20                   | PCI IOA in PCI bridge set 1                                            | C01C02C03C04             | <a href="#">Locations 11D/20 expansion unit</a>                   |
|                          | PCI IOA in PCI bridge set 2                                            | C06C07C08                |                                                                   |
| 57/91, 57/94, and 406/1D | PCI IOA in PCI bridge set 1                                            | -P1-I1-P1-I2-P1-I3-P1-I4 | <a href="#">Locations 57/91, 57/94, and 406/1D expansion unit</a> |
|                          | PCI IOA in PCI bridge set 2                                            | -P1-I5-P1-I6-P1-I7       |                                                                   |
|                          | PCI IOA in PCI bridge set 3                                            | -P1-I8-P1-I9-P1-I10      |                                                                   |
|                          | Embedded adapters in backplane 1 (left side), PCI bridge sets 2 and 3  | -P1                      |                                                                   |
|                          | PCI IOA in PCI bridge set 1                                            | -P2-I1-P2-I2-P2-I3-P2-I4 |                                                                   |
|                          | PCI IOA in PCI bridge set 2                                            | -P2-I5-P2-I6-P2-I7       |                                                                   |
|                          | PCI IOA in PCI bridge set 3                                            | -P2-I8-P2-I9-P2-I10      |                                                                   |
|                          | Embedded adapters in backplane 2 (right side), PCI bridge sets 2 and 3 | -P2                      |                                                                   |

Parent topic: [Symbolic FRUs](#)

## IOBRDG

The failing component is the RIO I/O bridge on the IPL path.

Use the table below to determine which FRU to replace and how to replace it.

Table 1. IOBRDG failing components

| System model                           | Name of symbolic FRU to locate | FRU name (replace in order, one at a time)                      | Link to locations information                                          |
|----------------------------------------|--------------------------------|-----------------------------------------------------------------|------------------------------------------------------------------------|
| ESCALA PL 250R-VL or ESCALA PL 450R-XS | IOBRDG                         | System backplane                                                | <a href="#">Locations model ESCALA PL 250R-VL or ESCALA PL 450R-XS</a> |
| ESCALA PL 250R-L                       | IOBRDG                         | System backplane                                                | <a href="#">Locations model ESCALA PL 250R-L</a>                       |
| ESCALA PL 250T/R                       | IOBRDG                         | System backplane                                                | <a href="#">Locations Model ESCALA PL 250T/R</a>                       |
| ESCALA PL 450T/R                       | IOBRDG                         | System backplane                                                | <a href="#">Locations Model ESCALA PL 450T/R</a>                       |
| ESCALA PL 850R/PL 1650R/R+             | IOBRDG                         | I/O backplane (primary unit)I/O backplane (secondary units 1 3) | <a href="#">Locations Model ESCALA PL 850R/PL 1650R/R+</a>             |
| 5/75                                   | IOBRDG                         | System backplane                                                | <a href="#">Locations model 5/75</a>                                   |
| ESCALA PL 3250R and ESCALA PL 6450R    | IOBRDG                         | Service processor card 0Service processor card 1                | <a href="#">Locations model ESCALA PL 3250R and ESCALA PL 6450R</a>    |

**This ends the procedure.**

Parent topic: [Symbolic FRUs](#)

---

## IO\_DEV

A storage device is the failing item.

Perform the following:

1. Is device location information available in the serviceable event view for this FRU?
  - ◆ **Yes:** Continue with the next step.
  - ◆ **No:** If the adapter controlling this device is listed in the FRU list then use that location code and continue with the next step. Otherwise work with the customer or your next level of support to determine the location of the device or its adapter by using SRC information, failing resource information, device tree or error message information. Then continue with the next step.
2. Use the unit type information in the location code to identify the type of unit where the device or device adapter is located. Then use the following table to exchange the failing item. The link to locations information will guide you to the correct exchange procedure.

**Note:** The location listed may be a logical path instead of the physical device location. The known device logical location codes are handled in the locations information for each unit type.

| Model or expansion unit    | FRU to location | Link to locations information |                                                               |
|----------------------------|-----------------|-------------------------------|---------------------------------------------------------------|
| ESCALA PL 250T/R           | Disk unit       | <a href="#">Locations</a>     | <a href="#">model ESCALA PL 250T/R</a>                        |
| ESCALA PL 450T/R           | Disk unit       | <a href="#">Locations</a>     | <a href="#">model ESCALA PL 450T/R</a>                        |
| ESCALA PL 850R/PL 1650R/R+ | Disk unit       | <a href="#">Locations</a>     | <a href="#">model ESCALA PL 850R/PL 1650R/R+</a>              |
| 50/74, 8079-002, 8093-002  | Disk unit       | <a href="#">Locations</a>     | <a href="#">50/74, 8079-002, and 8093-002 expansion units</a> |
| 50/79                      | Disk unit       | <a href="#">Locations</a>     | <a href="#">50/79 expansion unit</a>                          |
| 50/88, 05/88               | Disk unit       | <a href="#">Locations</a>     | <a href="#">50/88 and 05/88 expansion units</a>               |
| 50/94, 52/94, 8094-002     | Disk unit       | <a href="#">Locations</a>     | <a href="#">50/94, 52/94, and 8094-002 expansion units</a>    |
| 50/95, 05/95               | Disk unit       | <a href="#">Locations</a>     | <a href="#">50/95 and 05/95 expansion units</a>               |
| 57/91, 57/94, and 406/1D   | Disk unit       | <a href="#">Locations</a>     | <a href="#">57/91, 57/94, and 406/1D expansion unit</a>       |
| 11D/10, 11D/11, and 57/90  | Disk unit       | <a href="#">Locations</a>     | <a href="#">11D/10, 11D/11, and 57/90 expansion units</a>     |
| 11D/20                     | Disk unit       | <a href="#">Locations</a>     | <a href="#">11D/20 expansion unit</a>                         |

Parent topic: [Symbolic FRUs](#)

---

## IO\_HUB

The failing component is the RIO NIC on the IPL Path.

Use the table below to determine which FRU to replace and how to replace it.

**Note:** To simplify this information, secondary units on the ESCALA PL 850R/PL 1650R/R+ server are numbered 1 through 3-secondary unit 1 being nearest to the primary unit and secondary unit 3 being furthest.

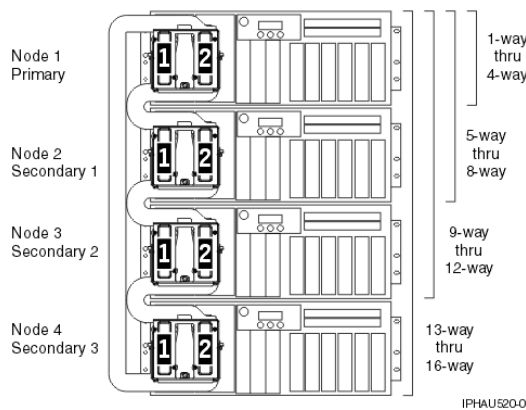


Table 1. IO\_HUB failing components

| System model                           | Name of symbolic FRU to locate | FRU name (replace in order, one at a time)                                                                                                                                           | Link to locations information                                                          |
|----------------------------------------|--------------------------------|--------------------------------------------------------------------------------------------------------------------------------------------------------------------------------------|----------------------------------------------------------------------------------------|
| ESCALA PL 250R-VL or ESCALA PL 450R-XS | IO_HUB                         | System backplane                                                                                                                                                                     | <a href="#">Locations</a> <a href="#">model ESCALA PL 250R-VL or ESCALA PL 450R-XS</a> |
| ESCALA PL 250R-L                       | IO_HUB                         | System backplane                                                                                                                                                                     | <a href="#">Locations</a> <a href="#">model ESCALA PL 250R-L</a>                       |
| ESCALA PL 250T/R                       | IO_HUB                         | System backplane                                                                                                                                                                     | <a href="#">Locations</a> <a href="#">Model ESCALA PL 250T/R</a>                       |
| ESCALA PL 450T/R                       | IO_HUB                         | System backplane                                                                                                                                                                     | <a href="#">Locations</a> <a href="#">Model ESCALA PL 450T/R</a>                       |
| ESCALA PL 850R/PL 1650R/R+             | IO_HUB                         | I/O backplane (primary unit)I/O backplane (secondary units 1 3)                                                                                                                      | <a href="#">Locations</a> <a href="#">Model ESCALA PL 850R/PL 1650R/R+</a>             |
| 5/75                                   | IO_HUB                         | System backplane                                                                                                                                                                     | <a href="#">Locations</a> <a href="#">model 5/75</a>                                   |
| ESCALA PL 3250R and ESCALA PL 6450R    | IO_HUB                         | For each node, starting with node 0:Bus adapter card 1Bus adapter card 2Bus adapter card 3Bus adapter card 4Bus adapter card 5Bus adapter card 6Bus adapter card 7Bus adapter card 8 | <a href="#">Locations</a> <a href="#">model ESCALA PL 3250R and ESCALA PL 6450R</a>    |

**This ends the procedure.**

**Parent topic:** [Symbolic FRUs](#)

---

## IOP

Replace the I/O processor.

Use the I/O processor location information in the Service Action Log if it is available. If the location is not available, find the address of the I/O Processor. See [System reference code \(SRC\) address formats](#). Use the address to find the location. See [Finding part locations](#).

**Parent topic:** [Symbolic FRUs](#)

---

## LBSADP1

This symbolic FRU is not supported on the system.

Continue with the next FRU in the failing item list.

**Parent topic:** [Symbolic FRUs](#)

---

## LBSADP2

This symbolic FRU is not supported on the system.

Continue with the next FRU in the failing item list.

**Parent topic:** [Symbolic FRUs](#)

---

## LBSADP3

This symbolic FRU is not supported on the system.

Continue with the next FRU in the failing item list.

**Parent topic:** [Symbolic FRUs](#)

---

## LBSADP4

This symbolic FRU is not supported on the system.

Continue with the next FRU in the failing item list.

**Parent topic:** [Symbolic FRUs](#)

---

## LBSADP5

This symbolic FRU is not supported on the system.

Continue with the next FRU in the failing item list.

**Parent topic:** [Symbolic FRUs](#)

---

## LBUSADP

This symbolic FRU is not supported on the system.

Continue with the next FRU in the failing item list.

Parent topic: [Symbolic FRUs](#)

---

## LICCODE

This procedure helps determine the preferred method of updating the server's Licensed Internal Code (LIC).

**Note:** In this procedure, the abbreviation LIC is synonymous with server firmware.

1. Check the level of the firmware on which the server is running. For information about checking firmware levels, see [Viewing existing firmware \(Licensed Internal Code\) levels](#).
 

Is the server firmware at the latest available level?

  - ◆ **No:** Continue with the next step.
  - ◆ **Yes:** **This ends the procedure.**
2. Is this the first time you are trying to update the server firmware while working on this problem?
  - ◆ **Yes:** Continue with the next step.
  - ◆ **No:** Go to symbolic FRU [SVCPROC](#) to update the platform LIC by replacing the service processor. **This ends the procedure.**
3. Is the server managed by an HMC?
  - ◆ **No:** Continue with the next step.
  - ◆ **Yes:** Go to step [7](#).
4. Is the system IPL'd and is the operating system running?
  - ◆ **No:** Continue with the next step.
  - ◆ **Yes:** Go to step [11](#).
5. Attempt to IPL the system from the present platform LIC side and start the operating system. Are you successful?
  - ◆ **No:** Continue with the next step.
  - ◆ **Yes:** Go to step [11](#).
6. Attempt to boot the system from the other side of the platform LIC, and start the operating system. Were you successful?
  - ◆ **No:** Go to symbolic FRU [SVCPROC](#) to update the platform LIC by replacing the service processor. **This ends the procedure.**
  - ◆ **Yes:** Go to step [11](#).
7. Normally, when power is first applied to the server, a series of progress codes display on the control panel. When activity on the control panel display stops, and 01 appears in the upper left corner of the display, the server is in standby state. Check the status of the server on the physical (on the server) or logical (on the HMC) control panel.

**Note:** The display indicates the server is in Standby state when 01 appears in the upper left corner.

When power is first applied to the server and before any action is taken to start the system or any partitions, did the server display 01 in the control panel?

- ◆ **Yes:** Continue with the next step.
- ◆ **No:** Go to symbolic FRU [SVCPROC](#) to update the platform LIC by replacing the service processor. **This ends the procedure.**

8. Perform the following to determine how the system is currently set to receive firmware updates:
  - a. Access ASMI (see [Accessing the Advanced System Management Interface](#)).
  - b. On the ASMI Welcome pane, type in your authorized service provider User ID and Password, and click Log In.
  - c. In the navigation area, expand System Configuration and then click Firmware Update Policy.
  - d. The system is currently set to receive firmware updates from the resource (either the HMC or the operating system) displayed in the *Setting* field.

Choose from the following:

- ◆ If the system is set to receive firmware updates from the operating system, continue with the next step.
  - ◆ If the system is set to receive firmware updates from the HMC, go to step 12.
9. Will the system IPL and run the service partition (from the current platform LIC side)?
    - ◆ **No:** Continue with the next step.
    - ◆ **Yes:** Go to step 11.
  10. Attempt to boot the system from the other side of the platform LIC, and start the service partition. Were you successful?
    - ◆ **No:** Go to step 12.
    - ◆ **Yes:** Continue with the next step.
  11. Determine what level of platform LIC is currently installed. Then go to [Getting server firmware and power subsystem firmware fixes](#) and update the platform LIC from the operating system. If you are still unable to update the platform LIC, contact your next level of support.

**Attention:** Be aware that a newer level of platform LIC may already have been downloaded before this problem occurred or when the problem was reported.

**This ends the procedure.**

12. Go to [Getting server firmware and power subsystem firmware fixes](#) and update the platform LIC from the HMC. If you are still unable to update the platform LIC, contact your next level of support. **This ends the procedure.**

Parent topic: [Symbolic FRUs](#)

---

## LITSTRP

Look here for information about LITSTRP symbolic FRU.

Use the following table to perform the appropriate action for the SRC you are working with.

| SRC      | Replace this FRU    | Link to locations information                                                       |
|----------|---------------------|-------------------------------------------------------------------------------------|
| 1xxx1D04 | Light strip (front) | <a href="#">Locations</a> <a href="#">model ESCALA PL 3250R and ESCALA PL 6450R</a> |
| 1xxx1D05 | Light strip (back)  |                                                                                     |

Parent topic: [Symbolic FRUs](#)

---

## LOADCY1

Cryptographic adapter licensed internal code not loaded.

The licensed internal code for the cryptographic adapter does not ship with the system. The licensed program 5733-CY1 Cryptographic Device Manager contains the licensed internal code for the cryptographic adapter.

Ensure that this licensed program is loaded on the system. If the licensed program is not loaded on the system, complete the following steps:

1. Vary off the cryptographic adapter.
2. Apply the licensed program to the system.
3. Vary on the card.

**Note:** The vary on may take up to 15 minutes.

Parent topic: [Symbolic FRUs](#)

---

## LOC\_SYS

A problem has occurred on the local (this) system with HSL OptiConnect.

The Service Action Log (SAL) code will attempt to identify the HSL/RIO loop number as a portion of the FRU's part description for this symbolic FRU. Search the SAL of this system for hardware and LIC problems. Correct any problems that you find with LIC or Network Interface Controller (NIC) / RIO controller hardware.

**This ends the procedure.**

Parent topic: [Symbolic FRUs](#)

---

## LPARCFG

There is a configuration problem with the system or a logical partition.

Perform any actions listed in the "Description/Action" column in the unit reference code table for the reference code.

Have the customer check processor and memory allocations of the system or to the partition. The customer must ensure that there are enough functioning processor and memory resources in the system for all the partitions. Processor or memory resources that failed during system IPL could have caused the IPL problem in the partition.

Have the customer check the bus and I/O processor allocations for the partition. The customer must ensure that the partition has load source and console I/O resources.

Have the customer check the IPL mode of the system or failing partition.

For further assistance, the customer should contact their software service provider, or see [Partitioning the server](#) for additional support.

**This ends the procedure.**

Parent topic: [Symbolic FRUs](#)

---

## LPARSUP

There is either an IPL problem, a main storage dump problem, or a software error with a partition.

Perform any actions listed in the "Description/Action" column in the SRC table.

During the IPL or main storage dump of a partition, a complex problem was detected. The serviceable event view on the HMC has to be searched or the SRC history list on the HMC for the partition with the problem has to be analyzed in sequence. If the partition is a "Guest" partition, then the SRC history list of the "Hosting" partition must be analyzed.

Contact your next level of hardware support.

**Parent topic:** [Symbolic FRUs](#)

---

## LSERROR

There was an error when the platform LIC attempted to locate the partition's load source.

Choose from the following:

- If the load source is a tape or optical device, exchange the media. If replacing the media does not work, look in the serviceable event view for other errors.
- If the load source is a disk drive, perform a D-mode IPL. Correct any errors found.

**This ends the procedure.**

**Parent topic:** [Symbolic FRUs](#)

---

## MA\_BRDG

The problem is the multi-adapter bridge hardware on a system bus.

Perform the following:

1. Is the location information for this failing component available in the problem view you are working with of the serviceable event user interface of an operating system, service processor, or Hardware Management Console (HMC)?
  - ◆ **No:** Continue with the next step.
  - ◆ **Yes:** Use this location information and go to step 3.
2. Perform the following:
  - a. Record the bus number, which is in word 7 of the reference code (see [Breaking down a RIO/HSL or PCI bus reference code](#) for help in determining the bus number).
  - b. To determine which enclosure, frame, or I/O unit contains the failing component, search for the bus number using one of the following interfaces:
    - ◇ HMC system configuration user interface
    - ◇ System configuration listing
  - c. Record the enclosure or unit's type/model or feature. Then continue with the next step.
3. The failing component is the FRU containing the multi-adapter bridge. Use the following table to identify the name of the FRU that is indicated by the location in the user interface you are working with, or by using the bus number you obtained previously in this procedure. Use the link to locations information to exchange the FRU.

Table 1. FRU containing the multi-adapter bridge

| Model or expansion unit                   | Name of FRU to exchange | Symbolic FRU to look for | Link to locations information                                          |
|-------------------------------------------|-------------------------|--------------------------|------------------------------------------------------------------------|
| ESCALA PL 250R-VL or<br>ESCALA PL 450R-XS | System backplane        | MA_BRDG                  | <a href="#">Locations model ESCALA PL 250R-VL or ESCALA PL 450R-XS</a> |



Service provider information

|                                   |                                                     |                       |                                                                             |
|-----------------------------------|-----------------------------------------------------|-----------------------|-----------------------------------------------------------------------------|
| ESCALA PL 250R-L                  | System backplane                                    | MA_BRDG               | Locations <a href="#">model ESCALA PL 250R-L</a>                            |
| ESCALA PL 250T/R                  | System backplane                                    | MA_BRDG               | Locations <a href="#">model ESCALA PL 250T/R</a>                            |
| ESCALA PL 450T/R                  | System backplane                                    | MA_BRDG               | Locations <a href="#">model ESCALA PL 450T/R</a>                            |
| ESCALA PL 850R/PL 1650R/R+        | I/O backplane on the primary unit or secondary unit | MA_BRDG               | Locations <a href="#">model ESCALA PL 850R/PL 1650R/R+</a>                  |
| 5/75                              | System backplane                                    | MA_BRDG               | Locations <a href="#">model 5/75</a>                                        |
| 50/74, 8079-002, 8093-002         | Expansion unit backplane                            | MA_BRDG               | Locations <a href="#">50/74, 8079-002, and 8093-002 expansion I/O units</a> |
| 50/79                             | Expansion unit backplane                            | MA_BRDG               | Locations <a href="#">50/79 expansion I/O unit</a>                          |
| 50/88, 05/88                      | Expansion unit backplane                            | MA_BRDG               | Locations <a href="#">50/88 and 05/88 expansion I/O units</a>               |
| 50/94, 52/94, 8094-002            | Expansion unit backplane                            | MA_BRDG               | Locations <a href="#">50/94, 52/94, and 8094-002 expansion I/O units</a>    |
| 50/95, 05/95                      | Backplane                                           | MA_BRDG               | Locations <a href="#">50/95 and 05/95 expansion I/O units</a>               |
| Type 1519 external xSeries server | Integrated xSeries adapter (IXA) card               | Follow the RIO cables | Locations <a href="#">Integrated xSeries adapter card (IXA)</a>             |
| 11D/10, 11D/11, and 57/90         | I/O unit backplane                                  | MA_BRDG               | Locations <a href="#">11D/10, 11D/11, and 57/90 expansion units</a>         |
| 11D/20                            | Backplane                                           | MA_BRDG               | Locations <a href="#">11D/20 expansion unit</a>                             |
| 57/91, 57/94, and 406/1D          | Backplane 1                                         | MA_BRDG               | Locations <a href="#">57/91, 57/94, and 406/1D expansion unit</a>           |
|                                   | Backplane 2                                         | MA_BRDG               |                                                                             |

**This ends procedure.**

**Parent topic:** [Symbolic FRUs](#)

## MABRCFG

The multi-adapter bridge hardware detected a configuration problem.

In some cases, the user interface view of the serviceable event will list more than one card position for this FRU's location. The problem may be with any one of the FRUs in those locations. When there is a list of locations in this FRU's location code, the card locations will be separated by commas. A range of card positions will show the starting card position, a colon, and the ending card position.

1. Are you working from the service event user interface from an operating system, service processor, or the HMC and there is a card position(s) listed with this failing item?
  - ◆ Yes: The listed card position(s) is where the error is located. Continue with the next step.

- ◆ No: Go to [MABIP53](#) to determine the card location where the multi-adapter bridge configuration error exists. Return here after locating the card, and continue with the next step.
2. Use the following table to determine the corrective action.

Table 1. Multi-adapter bridge errors

| Problem or message (these appear in uppercase in the console) | Meaning or corrective action                                                                                                                                                                                                                                                                                                                                                                                                                                                                                                                                                                                                                                                                                                                                                                                                                                                                                                                                                                                                                                                                                                                                                                                                                      |
|---------------------------------------------------------------|---------------------------------------------------------------------------------------------------------------------------------------------------------------------------------------------------------------------------------------------------------------------------------------------------------------------------------------------------------------------------------------------------------------------------------------------------------------------------------------------------------------------------------------------------------------------------------------------------------------------------------------------------------------------------------------------------------------------------------------------------------------------------------------------------------------------------------------------------------------------------------------------------------------------------------------------------------------------------------------------------------------------------------------------------------------------------------------------------------------------------------------------------------------------------------------------------------------------------------------------------|
| Multi-adapter bridge has no IOP for the I/O adapters.         | <ol style="list-style-type: none"> <li>1. System code detected one or more I/O adapters under the multi-adapter bridge specified in the DSA, but no I/O processor to control them. The I/O adapters are not available to the system. The problem view lists the card locations controlled by the multi-adapter bridge.<br/><br/>If you do not have the card locations listed in the problem view, find them by continuing with the next step. Otherwise, go to step 3.</li> <li>2. To locate the I/O adapters, search for the card locations controlled by the multi-adapter bridge. The multi-adapter bridge number is in the DSA (see <a href="#">DSA translation</a>). See <a href="#">Card positions</a> to determine all the card locations controlled by the multi-adapter bridge.</li> <li>3. To make the I/O adapters available to the system, install an I/O processor in a card slot controlled by the multi-adapter bridge or move the I/O adapters to a multi-adapter bridge with an I/O processor. When adding an IOP, place it in a card position that is ahead of the IOAs according to the "IOA Assignment Rules" table located in <a href="#">Finding part locations</a> for the frame type on which you are working.</li> </ol> |
| Card type not supported in this slot.                         | <p>System code detected a card type that is not supported in the multi-adapter bridge card location in which it is installed. Move the card to a location that will support that card type (check the installation instructions for the card to determine which card locations can support it).</p> <p>For reference codes where word 1 is B6006964 and word 4 is xxxxx2015, if the SAL does not show a card position for this error, then the card position can be determined by creating a Direct Select Address (DSA) from information in the reference code. To create the DSA, use the first 5 digits of word 7 and the 6th digit of word 5 followed by two zeros. Using this DSA, perform <a href="#">MABIP53</a> to determine the position of the card that is not supported in that slot.</p>                                                                                                                                                                                                                                                                                                                                                                                                                                             |
| I/O processor removed from multi-adapter bridge card slot.    | System code detected that an I/O processor card was located in that card location on the previous IPL. The I/O processor is no longer installed in that location.                                                                                                                                                                                                                                                                                                                                                                                                                                                                                                                                                                                                                                                                                                                                                                                                                                                                                                                                                                                                                                                                                 |
| I/O adapter unavailable due to moved I/O processor card.      | System code detected that the I/O processor which controlled the I/O adapter card specified in the DSA has been moved since the last IPL. The I/O adapter card is unavailable to the system.                                                                                                                                                                                                                                                                                                                                                                                                                                                                                                                                                                                                                                                                                                                                                                                                                                                                                                                                                                                                                                                      |
| IOA removed from multi-adapter bridge slot.                   | System code detected that the card location specified in the DSA had an I/O adapter installed on the previous IPL. The I/O adapter is no longer installed in that card location.                                                                                                                                                                                                                                                                                                                                                                                                                                                                                                                                                                                                                                                                                                                                                                                                                                                                                                                                                                                                                                                                  |
| I/O adapter replaced by I/O processor card.                   | System code detected that the card location specified in the DSA had an I/O adapter installed on the previous IPL. The I/O adapter has been replaced by an I/O processor.                                                                                                                                                                                                                                                                                                                                                                                                                                                                                                                                                                                                                                                                                                                                                                                                                                                                                                                                                                                                                                                                         |
| Multi-adapter bridge configuration change or error.           | System code has detected a change in the multi-adapter bridge configuration or a configuration error since the last IPL.                                                                                                                                                                                                                                                                                                                                                                                                                                                                                                                                                                                                                                                                                                                                                                                                                                                                                                                                                                                                                                                                                                                          |

|                                                             |                                                                                                                                                                                                                                                                                                                                                                                                                                                                                                                                                                                                                                                                                                                                                                                                                                                                                                                                                                                                                                                                                                                                                                                                                    |
|-------------------------------------------------------------|--------------------------------------------------------------------------------------------------------------------------------------------------------------------------------------------------------------------------------------------------------------------------------------------------------------------------------------------------------------------------------------------------------------------------------------------------------------------------------------------------------------------------------------------------------------------------------------------------------------------------------------------------------------------------------------------------------------------------------------------------------------------------------------------------------------------------------------------------------------------------------------------------------------------------------------------------------------------------------------------------------------------------------------------------------------------------------------------------------------------------------------------------------------------------------------------------------------------|
| PCI I/O processor rejected assignment or removal of an IOA. | <p>The I/O processor's (IOP) Licensed Internal Code (LIC) has rejected the assignment of an I/O adapter (IOA) to that IOP, or the IOP's LIC has rejected the removal of an IOA that the IOP owns.</p> <p>Word 5 of the reference code is the Direct Select Address (DSA) of the IOP. Word 7 of is the DSA of the IOA. To find the IOP and IOA, go to <a href="#">MABIP53</a> using the DSA.</p> <p>Use Hardware Service Manager (HSM) concurrent maintenance functions to assign or remove the IOA. See <a href="#">Hardware Service Manager</a> for details.</p> <p>Assignment failures can result from either of the following conditions:</p> <ul style="list-style-type: none"> <li>• The IOP is already at its capacity to accept IOA assignments.</li> <li>• The IOA is not a type supported by the IOP.</li> </ul> <p>Corrective action:</p> <ul style="list-style-type: none"> <li>• Add another IOP for LIC to assign the IOA to if necessary.</li> <li>• Reassign the IOA to another IOP using concurrent maintenance.</li> </ul> <p>Removal failures:</p> <ul style="list-style-type: none"> <li>• This is a LIC problem and should be reported.</li> <li>• Call your next level of support.</li> </ul> |
| Linux-owned slot - no IOP is allowed.                       | An IOP card was found in a PCI bridge set that is allocated to a Linux partition. The IOP will not be supported in this card position.                                                                                                                                                                                                                                                                                                                                                                                                                                                                                                                                                                                                                                                                                                                                                                                                                                                                                                                                                                                                                                                                             |

**This ends the procedure.**

Parent topic: [Symbolic FRUs](#)

---

## MAILBOX

Connection monitoring errors have been detected, indicating mailbox failures.

1. Are there any B1xxxxxx or B7xxxxxx SRCs from the system?
  - ◆ **No:** Continue with the next step.
  - ◆ **Yes:** Follow the service action for the first SRC that is listed. **This ends the procedure.**
2. There may be firmware fixes for this problem. Load and apply any platform firmware fixes or new levels of firmware using symbolic FRU [LICC0DE](#). Does the problem persist after updating the firmware?
  - ◆ **No: This ends the procedure.**
  - ◆ **Yes:** Continue to the next FRU in the list. **This ends the procedure.**

Parent topic: [Symbolic FRUs](#)

---

## MASBUS

The multi-adapter bridge detected a problem with a connection to a PCI adapter that it controls either in a physical card location or embedded in a FRU.

The problem is either in the bus between the multi-adapter bridge and the adapter, or with the card slot. The card location may or may not have an installed card.

- Are you working from the serviceable event view and a card location is listed with this FRU?
  - ◆ **Yes:** Then the listed card location is where the error is located. Continue with the next step.
  - ◆ **No:** Record the bus number value, BBBB, in word 7 of the reference code (see [Breaking down a RIO/HSL or PCI bus reference code](#)). Search for the bus number in the resource view available to you on the HMC or operating system, or in the System Configuration Listing, to determine which system unit or I/O unit contains the failing component. Record the unit's machine type, model, or feature and continue with the next step.
- The failing component is the FRU containing the physical or embedded card slot that is controlled by the multi-adapter bridge. Identify the system model, I/O unit, or machine type that is indicated by the location in the serviceable event view, or by using the bus number. Use the following table to find the appropriate service information.

Table 1. Failing component service information for MASBUS

| Model or expansion unit                       | Name of FRU to exchange                                | FRU location          | Link to locations information                                                               |
|-----------------------------------------------|--------------------------------------------------------|-----------------------|---------------------------------------------------------------------------------------------|
| ESCALA PL 250T/R                              | System unit logic planar                               | -P1                   | <a href="#">Locations</a> <a href="#">Model ESCALA PL 250T/R</a>                            |
| ESCALA PL 450T/R                              | System unit logic planar                               | -P1                   | <a href="#">Locations</a> <a href="#">Model ESCALA PL 450T/R</a>                            |
| ESCALA PL 850R/PL 1650R/R+                    | Logic planar for system primary unit or secondary unit | -P1                   | <a href="#">Locations</a> <a href="#">Model ESCALA PL 850R/PL 1650R/R+</a>                  |
| 5/75                                          | System backplane                                       | -P1                   | <a href="#">Locations</a> <a href="#">model 5/75</a>                                        |
| 50/74, 8079-002, 8093-002 expansion I/O tower | Tower card                                             | CB1                   | <a href="#">Locations</a> <a href="#">50/74, 8079-002, and 8093-002 expansion I/O units</a> |
| 50/79 expansion tower                         | Tower card                                             | CB1                   | <a href="#">Locations</a> <a href="#">50/79 expansion I/O unit</a>                          |
| 50/88, 05/88 expansion unit                   | Tower card                                             | CB1                   | <a href="#">Locations</a> <a href="#">50/88 and 05/88 expansion I/O units</a>               |
| 50/94, 52/94, 8094-002 expansion I/O unit     | Tower card                                             | CB1                   | <a href="#">Locations</a> <a href="#">50/94, 52/94, and 8094-002 expansion I/O units</a>    |
| 50/95, 05/95 expansion tower                  | Tower card                                             | CB1                   | <a href="#">Locations</a> <a href="#">50/95 and 05/95 expansion I/O units</a>               |
| Type 1519 external xSeries server             | Integrated xSeries adapter card                        | Follow the RIO cables | <a href="#">Locations</a> <a href="#">Integrated xSeries adapter card (IXA)</a>             |
| 11D/10, 11D/11, and 57/90                     | I/O unit logic planar                                  | -P1                   | <a href="#">Locations</a> <a href="#">11D/10 and 11D/11 and 57/90 expansion unit</a>        |
| 406/1D                                        | I/O unit logic planar                                  | -P1                   | <a href="#">Locations</a> <a href="#">61D</a>                                               |
|                                               |                                                        | -P2                   |                                                                                             |

This ends the procedure.

**Parent topic:** [Symbolic FRUs](#)

## MEDIA

The drive or media may be dirty, or the media may be defective.

1. Is the drive in a 3995 or 3996 optical library?
  - ◆ **Yes:** Try a different media. **This ends the procedure.**
  - ◆ **No:** Continue with the next step.
2. If it is an optical media, clean the drive (for 6330 DVD-RAM see the [Part number catalog](#) for the cleaning kit part number). If it is a tape media, clean the recording head in the tape unit.
3. Attempt the failing operation again. Does the operation complete successfully?
  - ◆ **No:** Replace the media. **This ends the procedure.**
  - ◆ **Yes:** The problem has been corrected. **This ends the procedure.**

Parent topic: [Symbolic FRUs](#)

---

## MEDIABP

Use this procedure to determine what Media backplane to replace on ESCALA PL 250T/R, ESCALA PL 450T/R, or an ESCALA PL 850R/PL 1650R/R+

The failing component is the media backplane. Use the following table to determine what FRU to replace and how to replace it.

| System model                                 | Name of symbolic FRU to locate | FRU name (Replace FRUs one at a time, in the order listed, from top to bottom.) | Link to locations information           |
|----------------------------------------------|--------------------------------|---------------------------------------------------------------------------------|-----------------------------------------|
| ESCALA PL 250T/R                             | MEDIABP                        | Media drive backplane                                                           | <a href="#">../iphau/locsqsf2.htm</a>   |
| ESCALA PL 450T/R,                            | MEDIABP                        | Media drive backplane                                                           | <a href="#">../iphau/loc550.htm</a>     |
| ESCALA PL 850R/PL 1650R/R+                   | MEDIABP                        | Media drive backplane                                                           | <a href="#">../iphau/locsql4mlx.htm</a> |
| Multiple 5/70's sequentially cabled together | MEDIABP                        | <b>Primary unit:</b> Media drive backplane                                      | <a href="#">../iphau/locsql4mlx.htm</a> |
|                                              |                                | <b>Secondary unit 1:</b> Media drive backplane                                  |                                         |
|                                              |                                | <b>Secondary unit 2:</b> Media drive backplane                                  |                                         |
|                                              |                                | <b>Secondary unit 3:</b> Media drive backplane                                  |                                         |

Parent topic: [Symbolic FRUs](#)

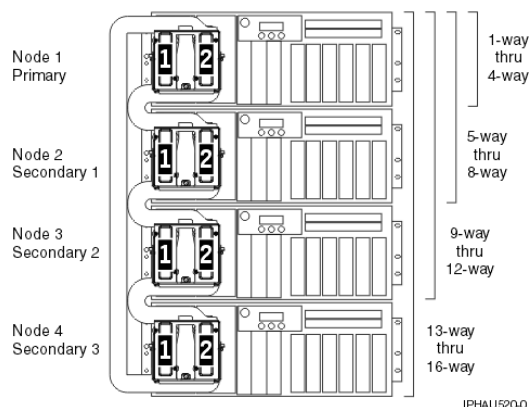
---

## MEMBRD

The failing component is the board the memory DIMMs plug into.

Use the following table to determine which FRU to replace and how to replace it.

**Note:** To simplify this information, secondary units on the ESCALA PL 850R/PL 1650R/R+ server are numbered 1 through 3-secondary unit 1 being nearest to the primary unit and secondary unit 3 being furthest.



| System model                           | Symbolic FRU to find | FRU name (replace one at a time, in order from top to bottom)                                                                                                                                                                                                 | Link to locations information                                                          |
|----------------------------------------|----------------------|---------------------------------------------------------------------------------------------------------------------------------------------------------------------------------------------------------------------------------------------------------------|----------------------------------------------------------------------------------------|
| ESCALA PL 250R-VL or ESCALA PL 450R-XS | MEMBRD               | system backplane                                                                                                                                                                                                                                              | <a href="#">Locations</a> <a href="#">model ESCALA PL 250R-VL or ESCALA PL 450R-XS</a> |
| ESCALA PL 250R-L                       | MEMBRD               | system backplane                                                                                                                                                                                                                                              | <a href="#">Locations</a> <a href="#">model ESCALA PL 250R-L</a>                       |
| ESCALA PL 250T/R                       | MEMBRD               | system backplane                                                                                                                                                                                                                                              | <a href="#">Locations</a> <a href="#">Model ESCALA PL 250T/R</a>                       |
| ESCALA PL 450T/R                       | MEMBRD               | processor card<br>1processor card 2                                                                                                                                                                                                                           | <a href="#">Locations</a> <a href="#">Model ESCALA PL 450T/R</a>                       |
| ESCALA PL 850R/PL 1650R/R+             | MEMBRD               | For each unit, starting with the primary unit and then the secondary units:processor card<br>1processor card 2                                                                                                                                                | <a href="#">Locations</a> <a href="#">Model ESCALA PL 850R/PL 1650R/R+</a>             |
| 5/75                                   | MEMBRD               | processor backplane                                                                                                                                                                                                                                           | <a href="#">Locations</a> <a href="#">model 5/75</a>                                   |
| ESCALA PL 3250R and ESCALA PL 6450R    | MEMBRD               | For each node starting with node 0:Memory card<br>1Memory card 2Memory card 3Memory card 4Memory card 5Memory card 6Memory card 7Memory card 8Memory card 9Memory card 10Memory card 11Memory card 12Memory card 13Memory card 14Memory card 15Memory card 16 | <a href="#">Locations</a> <a href="#">model ESCALA PL 3250R and ESCALA PL 6450R</a>    |

Parent topic: [Symbolic FRUs](#)

## MEMCTLR

The failing component is one of the memory controllers.

Use the following table to determine what FRU to replace and how to replace it.

**Note:** To simplify this information, secondary units on the ESCALA PL 850R/PL 1650R/R+ server are numbered 1 through 3-secondary unit 1 being nearest to the primary unit and secondary unit 3 being furthest.

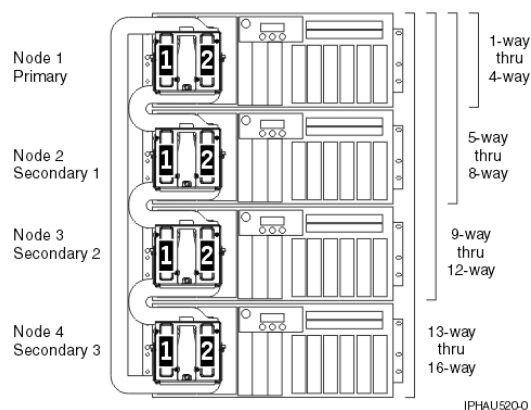


Table 1. MEMCTLR failing components

| System model                           | Name of symbolic FRU to locate | FRU name (replace in order, one at a time)                                                                  | Link to locations information                                                          |
|----------------------------------------|--------------------------------|-------------------------------------------------------------------------------------------------------------|----------------------------------------------------------------------------------------|
| ESCALA PL 250R-VL or ESCALA PL 450R-XS | MEMCTLR                        | System backplane                                                                                            | <a href="#">Locations</a> <a href="#">model ESCALA PL 250R-VL or ESCALA PL 450R-XS</a> |
| ESCALA PL 250R-L                       | MEMCTLR                        | System backplane                                                                                            | <a href="#">Locations</a> <a href="#">model ESCALA PL 250R-L</a>                       |
| ESCALA PL 250T/R                       | MEMCTLR                        | System backplane                                                                                            | <a href="#">Locations</a> <a href="#">Model ESCALA PL 250T/R</a>                       |
| ESCALA PL 450T/R                       | MEMCTLR                        | Processor card 1Processor card 2                                                                            | <a href="#">Locations</a> <a href="#">Model ESCALA PL 450T/R</a>                       |
| ESCALA PL 850R/PL 1650R/R+             | MEMCTLR                        | For each unit, starting with the primary unit and then the secondary units:Processor card 1Processor card 2 | <a href="#">Locations</a> <a href="#">Model ESCALA PL 850R/PL 1650R/R+</a>             |
| 5/75                                   | MEMCTLR                        | Processor backplane                                                                                         | <a href="#">Locations</a> <a href="#">model 5/75</a>                                   |
| ESCALA PL 3250R and ESCALA PL 6450R    | MEMCTLR                        | For each node starting with node 0:MCM 0MCM 1                                                               | <a href="#">Locations</a> <a href="#">model ESCALA PL 3250R and ESCALA PL 6450R</a>    |

**This ends the procedure.**

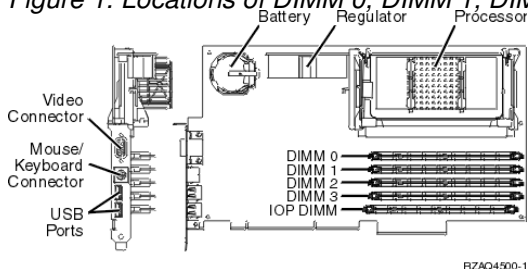
Parent topic: [Symbolic FRUs](#)

## MEMORY

Use this topic to view memory and location information for the 2890 and 2892 Integrated xSeries Server (IXS) cards.

### Memory for 2890 Integrated xSeries Server (IXS) card

Figure 1. Locations of DIMM 0, DIMM 1, DIMM 2 and DIMM 3 on 2890 Integrated xSeries Server (IXS) card.



One of the Pentium memory modules (DIMM 0, DIMM 1, DIMM 2, or DIMM 3) may be the failing item (see [Finding part numbers](#)).

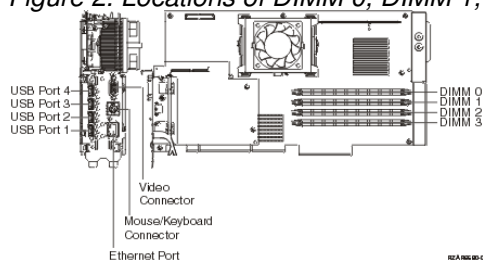
| Feature   | Size   |
|-----------|--------|
| 2795/2895 | 128 MB |
| 2796/2896 | 256 MB |
| 2797/2897 | 1 GB   |

#### Notes:

1. At least 1 Pentium memory module is required in positions DIMM 0, DIMM 1, DIMM 2 or DIMM 3.
2. An IXS adapter card IOP (see [Finding part numbers](#)) is required in the IOP DIMM position. This IOP memory module is NOT interchangeable with the Pentium memory module(s) in positions DIMM 0, DIMM 1, DIMM 2 or DIMM 3.

### Memory for 2892 Integrated xSeries Server (IXS) card

Figure 2. Locations of DIMM 0, DIMM 1, DIMM 2 and DIMM 3 on 2892 Integrated xSeries Server (IXS) card



One of the Pentium memory modules (DIMM 0, DIMM 1, DIMM 2, or DIMM 3) may be the failing item (see [Finding part numbers](#)).



| Feature   | Size   |
|-----------|--------|
| 0426/0446 | 512 MB |
| 0427/0447 | 1 GB   |

**Note:** At least **two** Pentium memory modules are required in positions DIMM 0 and DIMM 1, or positions DIMM 2 and DIMM 3.

Parent topic: [Symbolic FRUs](#)

## MEMDIMM

The failing component is one of the memory DIMMs.

Use the following table to determine which FRUs to replace. The locations information will give the exact location codes as well as links to part numbers and exchange procedures.

**Note:** To simplify this information, secondary units on the ESCALA PL 850R/PL 1650R/R+ server are numbered 1 through 3-secondary unit 1 being nearest to the primary unit and secondary unit 3 being furthest.

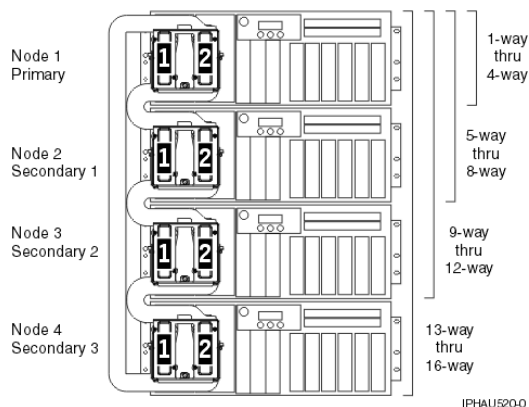


Table 1. MEMDIMM failing component

| System model     | Name of symbolic FRU to locate | FRU name (replace one at a time, top to bottom)                                                                            | Link to locations information                    |
|------------------|--------------------------------|----------------------------------------------------------------------------------------------------------------------------|--------------------------------------------------|
| ESCALA PL 250R-L | MEMDIMM                        | Memory module J0A<br>Memory module J0B<br>Memory module J0C<br>Memory module J0D<br>Memory module J2A<br>Memory module J2B | <a href="#">Locations model ESCALA PL 250R-L</a> |

Service provider information

|                                     |         |                                                                                                                                                                                                                                                                                                                                |                                                                                        |
|-------------------------------------|---------|--------------------------------------------------------------------------------------------------------------------------------------------------------------------------------------------------------------------------------------------------------------------------------------------------------------------------------|----------------------------------------------------------------------------------------|
|                                     |         | Memory module J2C<br>Memory module J2D                                                                                                                                                                                                                                                                                         |                                                                                        |
| ESCALA PL 250T/R                    | MEMDIMM | Memory module 1<br>Memory module 2<br>Memory module 3<br>Memory module 4<br>Memory module 5<br>Memory module 6<br>Memory module 7<br>Memory module 8                                                                                                                                                                           | <a href="#">Locations</a> <a href="#">Model</a><br>ESCALA PL 250T/R                    |
| ESCALA PL 450T/R                    | MEMDIMM | For each processor card, starting with processor card 1:<br><br>Memory module 1<br>Memory module 2<br>Memory module 3<br>Memory module 4<br>Memory module 5<br>Memory module 6<br>Memory module 7<br>Memory module 8                                                                                                           | <a href="#">Locations</a> <a href="#">Model</a><br>ESCALA PL 450T/R                    |
| ESCALA PL 850R/PL 1650R/R+          | MEMDIMM | For each processor card (starting with processor card 1) on each unit (starting with the primary unit and then the secondary units):<br><br>Memory module 1<br>Memory module 2<br>Memory module 3<br>Memory module 4<br>Memory module 5<br>Memory module 6<br>Memory module 7<br>Memory module 8                               | <a href="#">Locations</a> <a href="#">Model</a><br>ESCALA PL 850R/PL 1650R/R+          |
| 5/75                                | MEMDIMM | Memory modules, beginning with module 1 and ending with module 64                                                                                                                                                                                                                                                              | <a href="#">Locations</a> <a href="#">model 5/75</a>                                   |
| ESCALA PL 3250R and ESCALA PL 6450R | MEMDIMM | For each node starting with node 0:<br><br>Memory card 1<br>Memory card 2<br>Memory card 3<br>Memory card 4<br>Memory card 5<br>Memory card 6<br>Memory card 7<br>Memory card 8<br>Memory card 9<br>Memory card 10<br>Memory card 11<br>Memory card 12<br>Memory card 13<br>Memory card 14<br>Memory card 15<br>Memory card 16 | <a href="#">Locations</a> <a href="#">model</a><br>ESCALA PL 3250R and ESCALA PL 6450R |

**This ends the procedure.**

Parent topic: [Symbolic FRUs](#)

---

## MESSAGE

Messages provided with this symbolic FRU's description appear in the Service Action Log (SAL).

If the word MESSAGE is listed in the SAL as a part number, the description field provides information regarding proper handling of the error.

The following descriptions are used in MESSAGE FRUs. Follow the instructions provided when dealing with an error and the associated FRUs.

**Note:** The following messages are displayed in uppercase in the SAL. This list may not be complete if the level of service documentation does not match the level of LIC.

- Work all B600 6906 (or B700 6906) errors before this one.
- Cycle frame power before exchanging FRUS.
- Note: Replace FRUs one at a time.
- Linux owned slots - no IOP is allowed.

**This ends the procedure.**

Parent topic: [Symbolic FRUs](#)

---

## MOVEIOA

An incorrect hardware configuration was detected.

The I/O adapter used by a guest partition is on the same PCI bridge set as an I/O processor in another partition. Guest partition data may be lost if any of the following occur:

- A primary partition type D IPL is performed.
- The I/O adapter is moved to an partition.
- An error causes the logical partition (LPAR) configuration to not be used.

To correct the hardware configuration, either the I/O adapter or the I/O processor must be moved to a new card location.

Parent topic: [Symbolic FRUs](#)

---

## MSGxxxx

If you were sent here from a symbolic FRU with the format "MSGxxxx," use the following links to go to the message number's symbolic FRU.

**Note:** In additional information about the FRU or problem may have been included as part of the description.

The following messages are displayed in uppercase in the SAL view:

[MSG0001](#)

[MSG0002](#)

[MSG0003](#)

## MSG0005

**This ends the procedure.**

**Parent topic:** [Symbolic FRUs](#)

---

## MSG0001

This symbolic FRU represents a specific message to the service provider relative to the reference code or FRU list for cases where it is needed.

MSG0001: Work all B600 6906 (or B700 6906) errors before this one.

**Parent topic:** [Symbolic FRUs](#)

---

## MSG0002

This symbolic FRU represents a specific message to the service provider relative to the reference code or FRU list for cases where it is needed.

MSG0002: Cycle frame power before exchanging FRUS.

**Parent topic:** [Symbolic FRUs](#)

---

## MSG0003

This symbolic FRU represents a specific message to the service provider relative to the reference code or FRU list for cases where it is needed.

MSG0003: Note: Replace FRUs one at a time.

**Parent topic:** [Symbolic FRUs](#)

---

## MSG0005

This symbolic FRU represents a specific message to the service provider relative to the reference code or FRU list for cases where it is needed.

MSG0005: Linux owned slots - no IOP is allowed.

**Parent topic:** [Symbolic FRUs](#)

---

## NETSERV

The Integrated xSeries Server (IXS) is the failing item.

Call your Integrated xSeries Server (IXS) service provider.

**Parent topic:** [Symbolic FRUs](#)

---

## NEXTLVL

Contact your next level of support.

**Parent topic:** [Symbolic FRUs](#)

---

## NODEPL

The failing component is the node backplane.

Use the table below to determine which FRU to replace and how to replace it.

**Note:** To simplify this information, secondary units on the ESCALA PL 850R/PL 1650R/R+ server are numbered 1 through 3-secondary unit 1 being nearest to the primary unit and secondary unit 3 being furthest.

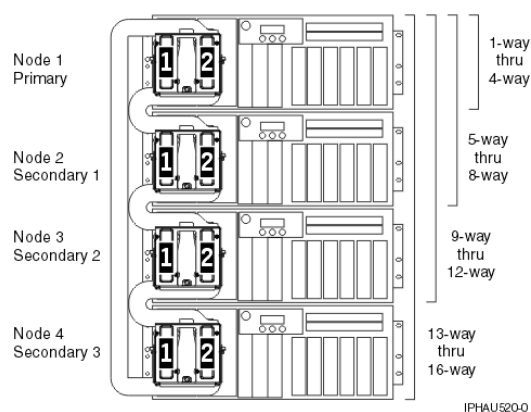


Table 1. NODEPL failing components

| System model                           | Name of symbolic FRU to locate | FRU name (replace in order, one at a time)                                                                                                                                                                                                                     | Link to locations information                                                          |
|----------------------------------------|--------------------------------|----------------------------------------------------------------------------------------------------------------------------------------------------------------------------------------------------------------------------------------------------------------|----------------------------------------------------------------------------------------|
| ESCALA PL 250R-VL or ESCALA PL 450R-XS | NODEPL                         | System backplane                                                                                                                                                                                                                                               | <a href="#">Locations</a> <a href="#">model ESCALA PL 250R-VL or ESCALA PL 450R-XS</a> |
| ESCALA PL 250R-L                       | NODEPL                         | System backplane                                                                                                                                                                                                                                               | <a href="#">Locations</a> <a href="#">model ESCALA PL 250R-L</a>                       |
| ESCALA PL 250T/R                       | NODEPL                         | System backplane                                                                                                                                                                                                                                               | <a href="#">Locations</a> <a href="#">Model ESCALA PL 250T/R</a>                       |
| ESCALA PL 450T/R                       | NODEPL                         | System backplane                                                                                                                                                                                                                                               | <a href="#">Locations</a> <a href="#">Model ESCALA PL 450T/R</a>                       |
| ESCALA PL 850R/PL 1650R/R+             | NODEPL                         | Primary unit, Regulator distribution connection backplane<br><br>Secondary unit 1, Regulator distribution connection backplane<br><br>Secondary unit 2, Regulator distribution connection backplane<br><br>Secondary unit 3, Regulator distribution connection | <a href="#">Locations</a> <a href="#">Model ESCALA PL 850R/PL 1650R/R+</a>             |

Service provider information

|                                     |        |                                                                              |                                                                                     |
|-------------------------------------|--------|------------------------------------------------------------------------------|-------------------------------------------------------------------------------------|
|                                     |        | backplane                                                                    |                                                                                     |
| 5/75                                | NODEPL | Processor backplane                                                          | <a href="#">Locations</a> <a href="#">model 5/75</a>                                |
| ESCALA PL 3250R and ESCALA PL 6450R | NODEPL | Node 0 backplane<br>Node 1 backplane<br>Node 2 backplane<br>Node 3 backplane | <a href="#">Locations</a> <a href="#">model ESCALA PL 3250R and ESCALA PL 6450R</a> |

**This ends the procedure.**

Parent topic: [Symbolic FRUs](#)

---

## NOFRUS

No failing items are identified for the reference code.

Parent topic: [Symbolic FRUs](#)

---

## NO\_PNUM

Diagnostic firmware could not determine a part number for the FRU.

To determine the part number, exchange procedure, and other service information, record the location of the FRU from the user interface you are working with. Locate the machine type and model of the unit you are working with in the table below. Follow the link to the locations table for the machine type and model you are working with, and then match the location code you recorded to one in the locations table.

| Model or expansion unit             | Link to locations information                                                           |
|-------------------------------------|-----------------------------------------------------------------------------------------|
| ESCALA PL 250R-L                    | <a href="#">Locations</a> <a href="#">model ESCALA PL 250R-L</a>                        |
| ESCALA PL 250T/R                    | <a href="#">Locations</a> <a href="#">model ESCALA PL 250T/R</a>                        |
| ESCALA PL 450T/R                    | <a href="#">Locations</a> <a href="#">model ESCALA PL 450T/R</a>                        |
| ESCALA PL 850R/PL 1650R/R+          | <a href="#">Locations</a> <a href="#">model ESCALA PL 850R/PL 1650R/R+</a>              |
| 5/75                                | <a href="#">Locations</a> <a href="#">model 5/75</a>                                    |
| ESCALA PL 3250R and ESCALA PL 6450R | <a href="#">Locations</a> <a href="#">model ESCALA PL 3250R and ESCALA PL 6450R</a>     |
| 50/74, 8079-002, 8093-002           | <a href="#">Locations</a> <a href="#">50/74, 8079-002, and 8093-002 expansion units</a> |
| 50/79                               | <a href="#">Locations</a> <a href="#">50/79 expansion unit</a>                          |
| 50/88, 05/88                        | <a href="#">Locations</a> <a href="#">50/88 and 05/88 expansion units</a>               |
| 50/94, 52/94, 8094-002              | <a href="#">Locations</a> <a href="#">50/94, 52/94, and 8094-002 expansion units</a>    |
| 50/95, 05/95                        | <a href="#">Locations</a> <a href="#">50/95 and 05/95 expansion units</a>               |
| Type 1519 external xSeries server   | <a href="#">Locations</a> <a href="#">Integrated xSeries adapter card (IXA)</a>         |
| 57/91, 57/94, and 406/1D            | <a href="#">Locations</a> <a href="#">57/91, 57/94, and 406/1D expansion unit</a>       |
| 11D/10, 11D/11, and 57/90           | <a href="#">Locations</a> <a href="#">11D/10, 11D/11, and 57/90 expansion units</a>     |
| 11D/20                              | <a href="#">Locations</a> <a href="#">11D/20 expansion unit</a>                         |

**This ends the procedure.**

Parent topic: [Symbolic FRUs](#)

---

## NSCABLE

The cable between the Integrated xSeries Adapter (IXA) card and the RS-485 port on the Integrated xSeries Server (IXS) is the failing item.

Parent topic: [Symbolic FRUs](#)

---

## NTDEVDR

The Windows server device driver may be causing the problem.

Contact your next level of support for assistance.

Parent topic: [Symbolic FRUs](#)

---

## NTLANDD

The Windows server virtual LAN device driver may be causing the problem.

Contact your next level of support for assistance.

Parent topic: [Symbolic FRUs](#)

---

## NTOPSYS

The Windows server operating system may be causing the problem.

Contact your next level of support for assistance.

Parent topic: [Symbolic FRUs](#)

---

## NTUSER

Indicates a Windows server user problem.

This problem may be caused by:

- User-initiated action
- A Windows user application
- No keyboard or mouse attached to the Integrated xSeries Server (IXS)

Contact your next level of support for assistance.

Parent topic: [Symbolic FRUs](#)

---

## NTVSCSI

The Windows server virtual SCSI device driver may be causing the problem.

Contact your next level of support for assistance.

Parent topic: [Symbolic FRUs](#)

---

## OPT\_CLN

Use the fiber optic cleaning kit and the fiber optic cleaning procedures in "SY27-2604 Fiber Optic Cleaning Procedures" for all fiber channel connections such as those used in optical high speed link (HSL) connections or fibre channel attached devices.

See [Part number catalog](#).

**This ends the procedure.**

**Parent topic:** [Symbolic FRUs](#)

---

## OPTLCBL

The cabling for an optical disk drive in the optical library needs to be checked.

The cabling may be incorrectly installed, or it may be defective.

Refer to the [All 3995 Publications and Documentation](#) Web site for more information.

**Parent topic:** [Symbolic FRUs](#)

---

## OPTLDRV

An optical disk drive in the optical library is failing.

Refer to the [All 3995 Publications and Documentation](#) Web site for more information.

**Parent topic:** [Symbolic FRUs](#)

---

## OPUSER

The failing item indicates that the operator of the system console or the control panel performed an incorrect action.

Contact your next level of support.

**Parent topic:** [Symbolic FRUs](#)

---

## OSLIC

An operating system has experienced a fatal error.

If the SRC that sent you here is of the form B6xx xxxx, then check for an PTF to correct the problem.

If the SRC that sent you here is of the form BAxx xxxx, then check for an AIX or Linux code patch to correct the problem.

If you need help finding the correct patches, or if this does not correct the problem, contact your next level of support.

**Parent topic:** [Symbolic FRUs](#)

---

## OSTERM

The operating system in a partition has terminated abnormally.



Use the HMC to look for a partition that has failed. It should have the same SRC in the SRC display history for the failed partition. Use the SRC given in this error to resolve the problem.

**Note:** This error has not been automatically sent to your service provider.

If problems continue, call your next level of support.

**Parent topic:** [Symbolic FRUs](#)

---

## PGDPART

Look here for information about PGDPART symbolic FRU.

1. Power off the frame.
2. Check that the tower card is connected and seated properly. See [TWRCARD](#).
3. Check that the power supplies are connected and seated properly. See [PWRSPPLY](#).
4. Power on the frame.
5. Is there a reference code 1xxx 2600, 2601, or 2603?
  - ◆ **No: This ends the procedure.**
  - ◆ **Yes:** Exchange the following FRUs one at a time (see [Finding part locations](#)):
    - ◇ Tower card (TWRCARD)
    - ◇ Power supplies (PWRSPPLY)
    - ◇ Memory cards (if installed)
    - ◇ Processor cards (if installed)
    - ◇ Backplane (SYSBKPL)

**This ends the procedure.**

**Parent topic:** [Symbolic FRUs](#)

---

## PIOCARD

The multi-adapter bridge hardware that controls PCI adapters and PCI card slots detected an error.

The failing component is the adapter in the location specified by the Direct Select Address (DSA) in the reference code. When possible, the diagnostic code will determine the FRU location for the serviceable event view.

1. Does the reference code start with B7xx?
  - ◆ **Yes:** Perform the following:
    - a. Record the DSA, which is word 7 of the reference code.
    - b. Locate the card specified in the DSA by going to [MABIP53](#). Return here after locating the FRU and continue with the next step.
  - ◆ **No:** Continue with the next step..
2. Are you working from the serviceable event view and a card location is listed with this FRU?
  - ◆ **Yes:** The error is located at the listed card location. Go to step 6.
  - ◆ **No:** Perform the following:
    - a. Record the DSA, which is word 7 of the reference code.
    - b. Locate the card specified in the DSA by going to [MABIP53](#). Return here after locating the FRU and continue with the next step.
3. Did you identify a single FRU location by using [MABIP53](#)?

- ◆ **Yes:** This is the location of the failing item. Go to step 6.
  - ◆ **No:** Continue with the next step.
4. Perform the following, referring to the remove and replace procedures for each FRU location you determined (you can find links to the locations information, and from there to the remove and replace procedures, in the table at the end of this procedure):
- a. Remove all of the adapter and/or IOP cards in the locations that are identified in the given range of card slots. Do not remove any FRUs with embedded adapters, only FRUs in PCI card slots.
  - b. Replace each card one at a time.

**Note:** For adapters controlled by IOPs, replace the IOP before any of the adapters.

Power on the unit (as instructed in the remove and replace procedure indicated by following the link in the following table) after you replace each card until either the problem reappears or you have replaced each card.

- c. Did the problem reappear?
    - ◇ **Yes:** The last card that you replaced before the problem appeared again is the failing item. **This ends the procedure.**
    - ◇ **No:** Continue with the next step.
5. Did you identify a FRU with embedded adapters when performing [MABIP53](#)?
- ◆ **Yes:** The problem is in the FRU with the embedded adapter. Continue with the next step and exchange that FRU.
  - ◆ **No:** The problem may be intermittent. Contact your next level of support. **This ends the procedure.**
6. Use the links in the table below to locate and replace the failing item(s).

Table 1. Failing item for symbolic FRU PIOCARD

| System model, expansion unit, or machine type | Name of FRU to exchange                                                | FRU location               | Link to locations information                                          |
|-----------------------------------------------|------------------------------------------------------------------------|----------------------------|------------------------------------------------------------------------|
| ESCALA PL 250R-VL or ESCALA PL 450R-XS        | PCIX adapter card                                                      | -P1-C12-C1<br>-P1-C13-C1   | <a href="#">Locations model ESCALA PL 250R-VL or ESCALA PL 450R-XS</a> |
|                                               | Embedded adapters in system unit logic planar, PCI bridge set 0        | P1                         |                                                                        |
| ESCALA PL 250R-L                              | PCI IOP or IOA card in PCI bridge set 0                                | -P2-C1<br>-P2-C2<br>-P2-C3 | <a href="#">Locations model ESCALA PL 250R-L</a>                       |
|                                               | Embedded adapters in system unit logic planar, PCI bridge sets 1 and 2 | -P1                        |                                                                        |
| ESCALA PL 250T/R                              | Embedded adapters in system unit logic planar, PCI bridge sets 1 and 2 | -P1-C1<br>-P1-C2<br>-P1-C4 | <a href="#">Locations model ESCALA PL 250T/R</a>                       |
|                                               | PCI IOP or IOA card in PCI bridge set 2                                | -P1-C3<br>-P1-C5<br>-P1-C6 |                                                                        |
|                                               | Embedded adapters in system unit logic planar, PCI bridge sets 1 and 2 | -P1                        |                                                                        |
| ESCALA PL 450T/R                              | PCI IOP or IOA card in PCI bridge set 1                                | -P1-C1<br>-P1-C2           | <a href="#">Locations model ESCALA PL 450T/R</a>                       |
|                                               | PCI IOP or IOA card in PCI bridge set 2                                | -P1-C3<br>-P1-C4<br>-P1-C5 |                                                                        |
|                                               |                                                                        | -P1                        |                                                                        |

Service provider information

|                              |                                                                            |                                      |                                                                     |
|------------------------------|----------------------------------------------------------------------------|--------------------------------------|---------------------------------------------------------------------|
|                              | Embedded adapters in system unit logic planar, PCI bridge sets 1 and 2     |                                      |                                                                     |
| ESCALA PL 850R/PL 1650R/R+   | PCI IOP or IOA card in PCI bridge set 2                                    | -P1-C1<br>-P1-C2                     | Locations<br>model ESCALA<br>PL 850R/PL<br>1650R/R+                 |
|                              | PCI IOP or IOA card in PCI bridge set 3                                    | -P1-C3<br>-P1-C4<br>-P1-C5<br>-P1-C6 |                                                                     |
|                              | Embedded adapters in system unit logic planar, PCI bridge sets 1, 2, and 3 | -P1                                  |                                                                     |
| 50/74, 8079-002,<br>8093-002 | PCI IOP or IOA in PCI bridge set 1                                         | C01<br>C02<br>C03<br>C04             | Locations<br>50/74,<br>8079-002, and<br>8093-002<br>expansion units |
|                              | PCI IOP or IOA in PCI bridge set 2                                         | C05<br>C06<br>C07<br>C09<br>C10      |                                                                     |
|                              | PCI IOP or IOA in PCI bridge set 3                                         | C11<br>C12<br>C13<br>C14<br>C15      |                                                                     |
| 50/79                        | PCI IOP or IOA in PCI bridge set 1                                         | C01<br>C02<br>C03<br>C04             | Locations<br>50/79<br>expansion unit                                |
|                              | PCI IOP or IOA in PCI bridge set 2                                         | C05<br>C06<br>C07<br>C09<br>C10      |                                                                     |
|                              | PCI IOP or IOA in PCI bridge set 3                                         | C11<br>C12<br>C13<br>C14<br>C15      |                                                                     |
| 50/88, 05/88                 | PCI IOP or IOA in PCI bridge set 1                                         | C01<br>C02<br>C03<br>C04             | Locations<br>50/88 and 05/88<br>expansion units                     |
|                              | PCI IOP or IOA in PCI bridge set 2                                         | C05<br>C06<br>C07<br>C08<br>C09      |                                                                     |
|                              | PCI IOP or IOA in PCI bridge set 3                                         | C11<br>C12<br>C13<br>C14<br>C15      |                                                                     |
| 50/94, 52/94, 8094-002       | PCI IOP or IOA in PCI bridge set 1                                         | C01<br>C02<br>C03<br>C04             | Locations<br>50/94, 52/94,<br>and 8094-002<br>expansion units       |
|                              | PCI IOP or IOA in PCI bridge set 2                                         | C05<br>C06<br>C07                    |                                                                     |

Service provider information

|                                   |                                                                                  |                                      |                                                                 |
|-----------------------------------|----------------------------------------------------------------------------------|--------------------------------------|-----------------------------------------------------------------|
|                                   |                                                                                  | C08<br>C09                           |                                                                 |
|                                   | PCI IOP or IOA in PCI bridge set 3                                               | C11<br>C12<br>C13<br>C14<br>C15      |                                                                 |
| 50/95, 05/95                      | PCI IOP or IOA in PCI bridge set 1                                               | C01<br>C02<br>C03<br>C04             | Locations<br>50/95 and 05/95<br>expansion units                 |
|                                   | PCI IOP or IOA in PCI bridge set 2                                               | C06<br>C07<br>C08                    |                                                                 |
| Type 1519 external xSeries server | Integrated xSeries adapter card                                                  | Follow RIO/HSL cable                 | Locations<br>Integrated xSeries adapter card (IXA)              |
| 11D/10, 11D/11, and 57/90         | PCI IOP or IOA in PCI bridge set 1                                               | -P1-I1<br>-P1-I2<br>-P1-I3           | Locations<br>11D/10,<br>11D/11, and<br>57/90<br>expansion units |
|                                   | PCI IOP or IOA in PCI bridge set 2                                               | -P1-I4<br>-P1-I5<br>-P1-I6           |                                                                 |
| 57/91, 57/94, and 406/1D          | PCI IOP or IOA in PCI bridge set 1                                               | -P1-I1<br>-P1-I2<br>-P1-I3<br>-P1-I4 | Locations<br>57/91, 57/94,<br>and 406/1D<br>expansion unit      |
|                                   | PCI IOP or IOA in PCI bridge set 2                                               | -P1-I5<br>-P1-I6<br>-P1-I7           |                                                                 |
|                                   | PCI IOP or IOA in PCI bridge set 3                                               | -P1-I8<br>-P1-I9<br>-P1-I10          |                                                                 |
|                                   | Embedded adapters in I/O unit logic planar (left side), PCI bridge sets 2 and 3  | -P1                                  |                                                                 |
|                                   | PCI IOP or IOA in PCI bridge set 1                                               | -P2-I1<br>-P2-I2<br>-P2-I3<br>-P2-I4 |                                                                 |
|                                   | PCI IOP or IOA in PCI bridge set 2                                               | -P2-I5<br>-P2-I6<br>-P2-I7           |                                                                 |
|                                   | PCI IOP or IOA in PCI bridge set 3                                               | -P2-I8<br>-P2-I9<br>-P2-I10          |                                                                 |
|                                   | Embedded adapters in I/O unit logic planar (right side), PCI bridge sets 2 and 3 | -P2                                  |                                                                 |

**This ends the procedure.**

**Parent topic:** [Symbolic FRUs](#)

## PLDUMP

A platform dump occurred.

1. Find the SRC that occurred with the platform dump.
  - a. On the command line, enter the Start System Service Tools command `STRSST`. If you cannot get to SST, use function 21 to get to DST. Go to [Dedicated Service Tools \(DST\)](#) in the [Service functions](#).
  - b. On the Start Service Tools Sign On display, type in a user ID with QSRV authority and password.
  - c. Select Start a service tool > Main storage dump manager > Work with copies of main storage dumps.
  - d. Display the platform dump summary for the time that the platform dump occurred.
  - e. The SRC is the value in the "SRC word 1" field of the Platform Dump Summary screen.
2. Use the SRC from the Platform Dump Summary screen and find the SRC in the Service action log (see [Using the Service Action Log](#)). The SRC occurred at or before the time that the platform dump occurred.
3. Did you find the SRC in the service action log?
  - ◆ **Yes:** Use the SRC to service the system. **This ends the procedure.**
  - ◆ **No:** The dump should be sent back to development for analysis, if it has not already been sent. **This ends the procedure.**

Parent topic: [Symbolic FRUs](#)

---

## PLUS

The list of possible failing items that are displayed online is not complete.

There is not enough space to display all of the failing items. See the complete list of possible failing items in the appropriate unit reference code table in [Reference codes](#).

Parent topic: [Symbolic FRUs](#)

---

## PPCIMIN

The affected component is a primary PCI bus in an I/O unit.

Use symbolic FRU [PRI\\_PCI](#) to determine the FRU(s) and service information.

**This ends the procedure.**

Parent topic: [Symbolic FRUs](#)

---

## PPCISYS

The failing component is the primary PCI bus in a system unit.

Use symbolic FRU [PRI\\_PCI](#) to determine the FRU(s) and service information.

**This ends the procedure.**

Parent topic: [Symbolic FRUs](#)

---

## PPCITWR

PPCITWR: Primary PCI bus in an I/O unit.

The failing component is the primary PCI bus under an HSL I/O bridge or RIO adapter in an I/O unit. Use symbolic FRU [PRI\\_PCI](#) to determine the FRU(s) and service information.

**This ends the procedure.**

Parent topic: [Symbolic FRUs](#)

---

## PRIMIOA

Replace the storage I/O adapter to which the auxiliary cache I/O adapter is connected.

1. Find the location of the auxiliary cache I/O adapter:
  - a. Determine the address of the auxiliary cache I/O adapter. See [System reference code \(SRC\) address formats](#).
  - b. Determine the location of the auxiliary cache I/O adapter. See [Finding part locations](#) for the model you are working on.
2. Are you working on a 571F/575B combination storage and auxiliary cache IOA card set (uses two card slot locations)?
  - ◆ **Yes:** Replace the entire card set. See [Finding part locations](#) for links to part number and removal information. **This ends the procedure.**
  - ◆ **No:** Continue with the next step.
3. Trace the SCSI cable from the auxiliary cache I/O adapter to the storage I/O adapter. This is the storage I/O adapter that you should replace.
4. Replace the storage I/O adapter that you just identified. See [Finding part locations](#) for links to part number and removal information.

**This ends the procedure.**

Parent topic: [Symbolic FRUs](#)

---

## PRI\_PCI

This is a primary PCI bus generated under a RIO adapter/HSL I/O bridge.

This bus can be in a system unit or I/O unit, and on some units this bus connects two FRUs.

1. Are you working from the serviceable event view and a card location is listed with this failing item?
  - ◆ **Yes:** Then the listed card location is where the error is located. Continue with the next step.
  - ◆ **No:** Record the bus number value, `BBBB`, in word 7 of the reference code (see [Breaking down a RIO/HSL or PCI bus reference code](#)). Search for the decimal bus number, using one of the following, to determine which frame or I/O unit contains the failing item.
    - ◇ System Configuration Listing
 Record the unit type or feature and continue with the next step.
2. Use the table below to determine the appropriate service information.

Table 1. Symbolic FRU to perform for PRI\_PCI

| Model or expansion unit containing the failing item                                    | Action                                                                                                                                             |
|----------------------------------------------------------------------------------------|----------------------------------------------------------------------------------------------------------------------------------------------------|
| ESCALA PL 250R-L, ESCALA PL 250T/R, ESCALA PL 450T/R, ESCALA PL 850R/PL 1650R/R+, 5/75 | Perform <a href="#">SYSBKPL</a> .                                                                                                                  |
| 50/74, 50/79, 8079-002, 8093-002                                                       | There are two potential failing items. Perform <a href="#">SIADPCD</a> . If the problem persists after powering on the frame or unit, then perform |

|                           |                                                                                                                                                                                                                                                                                       |
|---------------------------|---------------------------------------------------------------------------------------------------------------------------------------------------------------------------------------------------------------------------------------------------------------------------------------|
|                           | <p><a href="#">TWRPLNR</a>.</p> <p><b>Attention:</b> To prevent system VPD problems, do not replace both FRUs at the same time.</p>                                                                                                                                                   |
| 50/88, 05/88              | <p>There are two potential failing items. Perform <a href="#">SIADPCD</a>. If the problem persists after powering on the frame or unit, then perform <a href="#">TWRPLNR</a>.</p> <p><b>Attention:</b> To prevent system VPD problems, do not replace both FRUs at the same time.</p> |
| 50/94, 52/94, 8094-002    | <p>There are two potential failing items. Perform <a href="#">SIADPCD</a>. If the problem persists after powering on the frame or unit, then perform <a href="#">TWRPLNR</a>.</p> <p><b>Attention:</b> To prevent system VPD problems, do not replace both FRUs at the same time.</p> |
| 50/95, 05/95, 11D/20      | <p>There are two potential failing items. Perform <a href="#">SIADPCD</a>. If the problem persists after powering on the frame or unit, then perform <a href="#">TWRPLNR</a>.</p> <p><b>Attention:</b> To prevent system VPD problems, do not replace both FRUs at the same time.</p> |
| 11D/10, 11D/11, and 57/90 | <p>There are two potential failing items. Perform <a href="#">SIADPCD</a>. If the problem persists after powering on the frame or unit, then perform <a href="#">TWRPLNR</a>.</p> <p><b>Attention:</b> To prevent system VPD problems, do not replace both FRUs at the same time.</p> |
| 57/91, 57/94, and 406/1D  | Perform <a href="#">TWRPLNR</a> .                                                                                                                                                                                                                                                     |

**This ends the procedure.**

**Parent topic:** [Symbolic FRUs](#)

---

## PTFSRCH

Licensed Internal Code is the failing item. Look for fixes (PTFs) associated with the reference code and have the customer apply them.

Parent topic: [Symbolic FRUs](#)

---

## PTNNTWK

One or more connections to a partition have been lost.

1. Is the HMC reporting any other reference codes that indicate a loss of communication with other partitions?
  - ◆ **No:** Choose from the following:
    - ◇ If the partition is running AIX or Linux, go to step 2.
  - ◆ **Yes:** Go to [Reference codes](#) and resolve the first of these reference codes. **This ends the procedure.**
2. Perform the following:
  - a. Open a virtual terminal console to the partition (see [Virtual terminal](#)).
  - b. Verify that Service Resource Manager (SRM) is running properly by entering the following command:
 

```
lssrc -a |grep ServiceRM
```

If the state given for SRM is "inactive" then SRM is not running and needs to be restarted. If the state given is "active", then go to step 3.
3. Has the partition logged any LAN adapter or other LAN reference codes?
  - ◆ **No:** Work with the customer to find and resolve any network problems between the HMC and the partition. **This ends the procedure.**
  - ◆ **Yes:** Go to [Reference codes](#) and resolve these reference codes. **This ends the procedure.**

Parent topic: [Symbolic FRUs](#)

---

## PWRCBL

The failing item is the SPCN frame-to-frame cable or adapter.

The following list shows the possible failing items, and the cable or adapter lengths when appropriate (see [Part number catalog](#)):

- 6.0 meters
- 15.0 meters
- 30.0 meters
- SPCN optical cable (100.0 meters)
- SPCN optical adapter
- SPCN port cable (frame-to-node)
- Integrated xSeries server SPCN-Y cable assembly

**This ends the procedure.**

Parent topic: [Symbolic FRUs](#)

---

## PWROC

The battery charger is reporting a load fault.

1. Is the reference code 4414?
  - ◆ **No:** Go to [Start of call procedure](#).
  - ◆ **Yes:** Perform the first four steps of [PWR1906](#) to isolate the failing item, then return here and continue with the next step.
2. Is the reference code 4414 still present?
  - ◆ **No:** Continue with the next step.
  - ◆ **Yes:** Replace the battery power unit charger (see [Part number catalog](#)).

**This ends the procedure.**



3. Power on the system. Does the failing expansion unit power on successfully?

- ◆ **Yes:** Continue with the next step.
- ◆ **No:** Go to [Start of call procedure](#).

**This ends the procedure.**

4. Remove the ac line cord from the outlet. Does a battery power unit charger fault occur?

- ◆ **Yes:** Replace the battery power unit charger (see [Part number catalog](#)).

**This ends the procedure.**

- ◆ **No:** **This ends the procedure.**

Parent topic: [Symbolic FRUs](#)

---

## QDCCRLS

Licensed Internal Code is the failing item.

Look for PTFs associated with the reference code and have the customer apply them.

Parent topic: [Symbolic FRUs](#)

---

## QSYSOPR

Look here for information about QSYSOPR symbolic FRU.

For more information, look in the System Operator message queue for a message with the same date and time. Perform any actions defined in the message.

Parent topic: [Symbolic FRUs](#)

---

## REFER

Look here for information about REFER symbolic FRU.

If the first four characters of the SRC are 3995, consult the [All 3995 Publications and Documentation Web site](#). If the first four characters of the SRC are 3996, consult the 3996 Maintenance Information shipped with the 3996 Optical Library.

Parent topic: [Symbolic FRUs](#)

---

## REM\_NIC

One end of the failed link is a system unit other than the one reporting this error.

In a cluster, all system units should send a warning to the other system units in the cluster when they are about to perform a controlled power down. This error could occur when a system unit leaves the cluster without issuing any warning to other system units. If the system unit is not reporting due to a failed cable or HSL hardware, replacing the FRUs in this error log entry will correct the problem.

However, the system unit may have been powered down immediately, or powered down because of an error. If this is the case, service any errors in the other system unit, or power the other system unit back on. When the other system unit reports in, the loop will be complete and this error can be closed.

**This ends the procedure.**

Parent topic: [Symbolic FRUs](#)

---

## REM\_SYS

A problem has occurred in a remote system that is in an HSL OptiConnect loop.

If the value of the first half of word 7 in the reference code is greater than or equal to 0680, then this value is the hexadecimal RIO loop number. The Service Action Log (SAL) code will attempt to identify the RIO loop number of the local system and the serial number of the remote system as a portion of the part description for this symbolic FRU. If the SAL could not identify the serial number of the remote system, then check all the systems which are connected to the local RIO loop identified in the reference code or the SAL. Search the SAL of the remote system(s) for hardware and LIC problems. Correct any problems you find with LIC or Network Interface Controller (NIC) / RIO controller hardware.

**This ends the procedure.**

**Parent topic:** [Symbolic FRUs](#)

## SIADPCD

The failing component is the HSL I/O bridge card or RIO adapter card in an I/O unit, or the integrated xSeries adapter card in an xSeries server.

- Are you working from the serviceable event view and do you know the type, model or feature, and serial number of the I/O unit where this failing component is located?
  - ◆ **Yes:** Continue with the next step.
  - ◆ **No:** Record the bus number value (BBBB) in word 7 of the reference code (see [Breaking down a RIO/HSL or PCI bus reference code](#)). Then search for the bus number in the system configuration listing to determine which frame or I/O unit contains the failing component. Then continue with the next step.
- Use the following table to find the appropriate service information.

Table 1. SIADPCD service information

| Unit containing the failing item  | Name of FRU to exchange         | Symbolic FRU         | Link to locations information                                           |
|-----------------------------------|---------------------------------|----------------------|-------------------------------------------------------------------------|
| 50/74, 8079-002, 8093-002         | RIO adapter card                | SIADPCD              | <a href="#">Locations 50/74, 8079-002, and 8093-002 expansion units</a> |
| 50/79                             | RIO adapter card                | SIADPCD              | <a href="#">Locations 50/79 expansion unit</a>                          |
| 50/88, 05/88                      | RIO adapter card                | SIADPCD              | <a href="#">Locations 50/88 and 05/88 expansion units</a>               |
| 50/94, 52/94, 8094-002            | RIO adapter card                | SIADPCD              | <a href="#">Locations 50/94, 52/94, and 8094-002 expansion units</a>    |
| 50/95, 05/95                      | RIO adapter card                | SIADPCD              | <a href="#">Locations 50/95 and 05/95 expansion units</a>               |
| Type 1519 external xSeries server | Integrated xSeries adapter card | Follow RIO/HSL cable | <a href="#">Locations Integrated xSeries adapter card (IXA)</a>         |
| 11D/10, 11D/11, and 57/90         | RIO adapter card                | SIADPCD              | <a href="#">Locations 11D/10, 11D/11, and 57/90 expansion units</a>     |
| 11D/20                            | RIO/HSL adapter                 | SIADPCD              | <a href="#">Locations 11D/20 expansion unit</a>                         |
| 57/91, 57/94, and 406/1D          | Backplane 1 (not the riser)     | SIADPCD              | <a href="#">Locations 57/91, 57/94, and 406/1D expansion unit</a>       |
|                                   | Backplane 2 (not the riser)     | SIADPCD              |                                                                         |

**This ends the procedure.**

Parent topic: [Symbolic FRUs](#)

---

## SI\_CARD

The failing component is the RIO adapter card in the system unit.

Use this table to find the appropriate service information for the failing component.

| System model                                            | Symbolic FRU to find | Name of FRU to exchange                                         | Link to locations                                                                                                    |
|---------------------------------------------------------|----------------------|-----------------------------------------------------------------|----------------------------------------------------------------------------------------------------------------------|
| ESCALA PL 250T/R, PL 250T/R+ or PL 450T/R-L+            | SI_CARD              | System backplane                                                | <a href="#">Locations</a> <a href="#">model</a><br>ESCALA PL 250T/R,<br>ESCALA PL 250T/R+ or<br>ESCALA PL 450T/R-L+  |
| ESCALA PL 450T/R, PL 450T/R+ or PL 850T/R-L+            | SI_CARD              | RIO adapter card                                                | <a href="#">Locations</a> <a href="#">model</a><br>ESCALA PL 450T/R,<br>ESCALA PL 450T/R+ or<br>ESCALA PL 850T/R-L+, |
| ESCALA PL 850R/PL 1650R/R+                              | SI_CARD              | RIO adapter card (for the primary unit and each secondary unit) | <a href="#">Locations</a> <a href="#">model</a><br>ESCALA PL 1650R-L+<br>and ESCALA PL 850R/PL 1650R/R+              |
| 5/75                                                    | SI_CARD              | System backplane                                                | <a href="#">Locations</a> <a href="#">model</a> 5/75                                                                 |
| ESCALA PL 3250R, PL 3250R+, ESCALA PL 6450 or PL 6450R+ | SI_CARD              | Bus adapter card 1 through bus adapter card 8 (for each node)   | <a href="#">Locations</a> <a href="#">model</a><br>ESCALA PL 3250R and<br>ESCALA PL 6450R                            |

**This ends the procedure.**

Parent topic: [Symbolic FRUs](#)

---

## SICNTRL

The failing component is the network interface controller (NIC)/RIO controller.

- Do you have a location code for this FRU in the serviceable event view?
  - ◆ **No:** Continue with the next step.
  - ◆ **Yes:** Go to step 4.
- Is the first half of word 7 of the reference code greater than or equal to 0680?
  - ◆ **No:** Continue with the next step.
  - ◆ **Yes:** This is a valid loop number and can be correlated to a position using [Converting the loop number to NIC port location labels](#). Record the location code and go to step 4.
- Since the first four characters of word 7 are less than 0680, they represent the system bus number. Do you have access to a system configuration listing?
  - ◆ **No:** Contact your next level of support.

**This ends the procedure.**

- ◆ **Yes:** Use the system configuration listing to determine which HSL/RIO loop number the system bus is connected to. Then, determine the FRU's location using [Converting the loop number to NIC port location labels](#). Once you have the FRU's location, continue with the next step.
- Use the table below to find the appropriate service information for this FRU.

Table 1. FRU containing the NIC/RIO controller

| System model                                    | Name of FRU to exchange                    | Symbolic FRU | Link to locations information                                                       |
|-------------------------------------------------|--------------------------------------------|--------------|-------------------------------------------------------------------------------------|
| ESCALA PL 250T/R                                | System backplane                           | SICNTRL      | <a href="#">Locations</a> <a href="#">Model ESCALA PL 250T/R</a>                    |
| ESCALA PL 850R/PL 1650R/R+                      | I/O backplane                              | SICNTRL      | <a href="#">Locations</a> <a href="#">Model ESCALA PL 850R/PL 1650R/R+</a>          |
| ESCALA PL 850R/PL 1650R/R+ with secondary units | RIO/HSL adapter card                       | SICNTRL      | <a href="#">Locations</a> <a href="#">Model ESCALA PL 850R/PL 1650R/R+</a>          |
| 5/75                                            | System backplane                           | SICNTRL      | <a href="#">Locations</a> <a href="#">model 5/75</a>                                |
| ESCALA PL 3250R and ESCALA PL 6450R             | RIO/HSL or InfiniBand adapter card in node | SICNTRL      | <a href="#">Locations</a> <a href="#">model ESCALA PL 3250R and ESCALA PL 6450R</a> |

**This ends the procedure.**

Parent topic: [Symbolic FRUs](#)

---

## SIIOADP

SIIOADP: RIO adapter/HSL I/O bridge (in a system unit or I/O unit).

**Note:** In the following procedures, the term *RIO adapter* refers to either a RIO adapter or an HSL I/O bridge, depending on the system you are working on.

- Is a location for this FRU given in the serviceable event view?
  - ◆ **Yes:** Use that location and [Table 1](#) to find and replace the failing part. **This ends the procedure.**
  - ◆ **No:** Continue with the next step.

**Note:** In most circumstances, the SRC logged by the system firmware calls out a FRU list. In very few circumstances (as in the following examples), the failure requires immediate system termination.

### Example: Symptoms

```

1 B7006981 RIO/HSL (bridge) bus adapter failure SRC
2 B70069XX SRC Format 62
3 00010002 Component ID field must be an exact match
4 14993203 Code Model and PRC must be an exact match
5 FRUCALLO Decode this when the SRC is 6906 or 6907
6 FRUCALLO Decode this when the SRC is 6981
7 00000000

```

**Example: SRC 6981**

```

1 B7006981
2 00000062
3 00010002
4 14993203
6 00044000
7 00000000

```

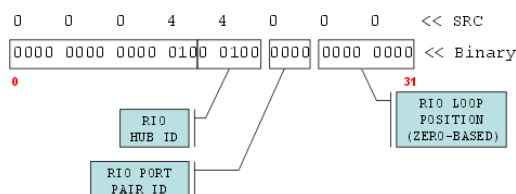
When immediate termination occurs, the SRC does not provide a FRU callout. The following steps describe how to determine the FRU callout.

2. Isolate the RIO adapter FRU indicated by the data in word 5 (when the SRC is 6906 or 6907) or word 6 (when the SRC is 6981) of the SRC by completing the following steps:

**Note:** Replace only the FRU with the RIO adapter FRU.

- a. Use the following example as a guide to locate and record the following binary values from word 5 or word 6 of the SRC:

- ◇ RIO hub ID
- ◇ RIO port pair ID
- ◇ RIO loop position

**Example: Decoding FRU Callout 00044000**

- b. Convert the binary values for the RIO hub ID, the RIO port pair ID, and the RIO loop position to decimal (use [Table 2](#)). Record these values for later use.
3. Each RIO hub controls two RIO loops, specified as the *first* and *second* loop. Use the following list to determine and record which of these two RIO loops is indicated in word 6 of the SRC:
  - ◆ When the binary value of the RIO port pair ID is 0000, the SRC indicates the **first** RIO loop
  - ◆ When the binary value of the RIO port pair ID is 0001, the SRC indicates the **second** RIO loop
4. To isolate the failing RIO adapter, you will walk the cabling for the specified RIO loop from the leading port to the trailing port. To determine the RIO loop number and RIO port location code for the leading port, do the following:
  - a. Make sure you have the following values at hand, then continue to the next step.
    - ◇ The decimal value for the RIO hub ID
    - ◇ The RIO loop indicated by the RIO port pair ID
  - b. Compare the values from the previous step to the location table and graphic for the model that you are working on. (From the following list, click the link for the model you are working on to display the appropriate table and graphic.) Refer to the location table and graphic and record the values for the RIO loop number and the RIO port location code. Then continue to the next step.
    - ◇ [Model ESCALA PL 250T/R](#)
    - ◇ [Model ESCALA PL 450T/R](#)
    - ◇ [Model ESCALA PL 850R/PL 1650R/R+](#)
    - ◇ [Model 5/75](#)
    - ◇ [Models ESCALA PL 3250R and ESCALA PL 6450R](#)
5. Isolate the failing RIO adapter by walking the cabling for the specified RIO loop from the leading port to the trailing port. Do the following:
  - a. Begin walking the cabling by starting at the RIO loop number and RIO port location code that you recorded in step 4.b.
  - b. Starting with 0 (zero) for the first RIO adapter on the loop, follow the loop cabling and count each RIO adapter in the order it is cabled. For example, the first RIO adapter is 0, the next is 1, the next is 2, and so on.
  - c. Continue this process until you count up to the decimal value of the RIO loop position. The RIO adapter that corresponds to the value of the RIO loop position is the failing RIO adapter.

**Note: Concurrent maintenance** requires that you make a change to the previous procedure for counting the RIO adapters on the loop. If concurrent maintenance was performed to attach one or more additional RIO adapters to this loop and the server has not been IPL'ed after the adapters were added, then **exclude the added RIO adapters as you make the initial count**. If the RIO loop position exceeds the number of RIO adapters, continue by counting the added RIO adapters in the order they were added to the loop.

- Exchange the failing RIO adapter. To determine the FRU part number, the FRU location, and the exchange procedure for the FRU, use [Table 1](#) to find and replace the failing part. **This ends the procedure.**

Table 1. SIIOADP service information

| Unit containing the failing item    | Name of FRU to exchange                                  | Symbolic FRU     | Link to locations information                                                           |
|-------------------------------------|----------------------------------------------------------|------------------|-----------------------------------------------------------------------------------------|
| ESCALA PL 250R-L                    | System backplane                                         | SIIOADP          | <a href="#">Locations</a> <a href="#">model ESCALA PL 250R-L</a>                        |
| ESCALA PL 250T/R                    | System backplane                                         | SIIOADP          | <a href="#">Locations</a> <a href="#">model ESCALA PL 250T/R</a>                        |
| ESCALA PL 450T/R                    | System backplane                                         | SIIOADP          | <a href="#">Locations</a> <a href="#">model ESCALA PL 450T/R</a>                        |
| ESCALA PL 850R/PL 1650R/R+          | I/O backplane on system primary unit or a secondary unit | SIIOADP          | <a href="#">Locations</a> <a href="#">model ESCALA PL 850R/PL 1650R/R+</a>              |
| 5/75                                | System backplane                                         | SIIOADP          | <a href="#">Locations</a> <a href="#">model 5/75</a>                                    |
| ESCALA PL 3250R and ESCALA PL 6450R | Logic planar for the system node                         | SIIOADP          | <a href="#">Locations</a> <a href="#">model ESCALA PL 3250R and ESCALA PL 6450R</a>     |
| 50/74, 8079-002, 8093-002           | RIO adapter card                                         | SIIOADP          | <a href="#">Locations</a> <a href="#">50/74, 8079-002, and 8093-002 expansion units</a> |
| 50/79                               | RIO adapter card                                         | SIIOADP          | <a href="#">Locations</a> <a href="#">50/79 expansion unit</a>                          |
| 50/88, 05/88                        | RIO adapter card                                         | SIIOADP          | <a href="#">Locations</a> <a href="#">50/88 and 05/88 expansion units</a>               |
| 50/94, 52/94, 8094-002              | RIO adapter card                                         | SIIOADP          | <a href="#">Locations</a> <a href="#">50/94, 52/94, and 8094-002 expansion units</a>    |
| 50/95, 05/95                        | RIO adapter card                                         | SIIOADP          | <a href="#">Locations</a> <a href="#">50/95 and 05/95 expansion units</a>               |
| Type 1519 external xSeries server   | Integrated xSeries adapter card                          | Follow RIO cable | <a href="#">Locations</a> <a href="#">Integrated xSeries adapter card (IXA)</a>         |
| 11D/10, 11D/11, and 57/90           | RIO adapter card                                         | SIIOADP          | <a href="#">Locations</a> <a href="#">11D/10, 11D/11, and 57/90 expansion units</a>     |
| 11D/20                              | RIO adapter card                                         | SIIOADP          | <a href="#">Locations</a> <a href="#">11D/20 expansion unit</a>                         |
| 57/91, 57/94, 406/1D                | Backplane 1 (not the riser)                              | SIIOADP          | <a href="#">Locations</a> <a href="#">57/91, 57/94, and 406/1D expansion units</a>      |
|                                     | Backplane 2 (not the riser)                              | SIIOADP          |                                                                                         |

Table 2. Binary to decimal conversion for RIO hub ID and RIO loop position

| RIO hub ID or RIO loop position binary value | Decimal conversion of binary value |
|----------------------------------------------|------------------------------------|
| xxx0 0000                                    | 0                                  |
| xxx0 0001                                    | 1                                  |
| xxx0 0010                                    | 2                                  |

Service provider information

|           |    |
|-----------|----|
| xxx0 0011 | 3  |
| xxx0 0100 | 4  |
| xxx0 0101 | 5  |
| xxx0 0110 | 6  |
| xxx0 0111 | 7  |
| xxx0 1000 | 8  |
| xxx0 1001 | 9  |
| xxx0 1010 | 10 |
| xxx0 1011 | 11 |
| xxx0 1100 | 12 |
| xxx0 1101 | 13 |
| xxx0 1110 | 14 |
| xxx0 1111 | 15 |
| xxx1 0000 | 16 |
| xxx1 0001 | 17 |
| xxx1 0010 | 18 |
| xxx1 0011 | 19 |
| xxx1 0100 | 20 |
| xxx1 0101 | 21 |
| xxx1 0110 | 22 |
| xxx1 0111 | 23 |
| xxx1 1000 | 24 |
| xxx1 1001 | 25 |
| xxx1 1010 | 26 |
| xxx1 1011 | 27 |
| xxx1 1100 | 28 |
| xxx1 1101 | 29 |
| xxx1 1110 | 30 |
| xxx1 1111 | 31 |

Parent topic: [Symbolic FRUs](#)

---

## SIIOADP: RIO loop location information

The FRU SIIOADP directed you to this page.

### RIO loop SIIOADP

The following tables and diagrams provide hub, port, and location code information that you need to determine the RIO loop number and RIO port location code. To use the location information, you must have the following information that you recorded when performing FRU SIIOADP at hand:

- The decimal value for the RIO hub ID
- The RIO loop indicated by the RIO port pair ID

Compare those values to the location information for the model that you are working on. Refer to the following location table and graphic for the model you are working on, and record the values for the RIO loop number and the RIO port location code.

- [Model ESCALA PL 250T/R](#)
- [Model ESCALA PL 450T/R](#)
- [Model ESCALA PL 850R/PL 1650R/R+](#)
- [Model 5/75](#)
- [Models ESCALA PL 3250R and ESCALA PL 6450R](#)

Then, return to the step in FRU SIIOADP that sent you here.

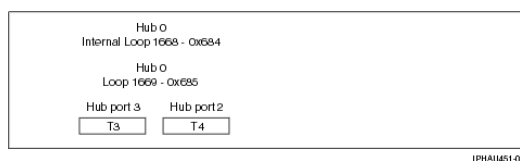
### Model ESCALA PL 250T/R

For clarity, the location information is provided as text (in the following table) and as a [graphic diagram](#).

Table 1. Model ESCALA PL 250T/R SIIOADP RIO loop location information

| Hub (decimal) | Hub loop | Loop number | Location code for leading port of the loop |
|---------------|----------|-------------|--------------------------------------------|
| 0             | First    | 1668        | Internal                                   |
| 0             | Second   | 1669        | P1-T4                                      |

### Model ESCALA PL 250T/R RIO loop diagram



### Model ESCALA PL 450T/R

For clarity, the location information is provided as text (in the following table) and as a [graphic diagram](#).

Table 2. Model ESCALA PL 450T/R SIIOADP RIO loop location information

| Hub (decimal) | Hub loop | Loop number | Location code for leading port of the loop |
|---------------|----------|-------------|--------------------------------------------|
| 0             | First    | 1668        | Internal                                   |
| 0             | Second   | 1669        | P1-T12                                     |
| 4             | First    | 1676        | P1_C6-T2                                   |

### Model ESCALA PL 450T/R RIO loop diagram





**Model ESCALA PL 850R/PL 1650R/R+**

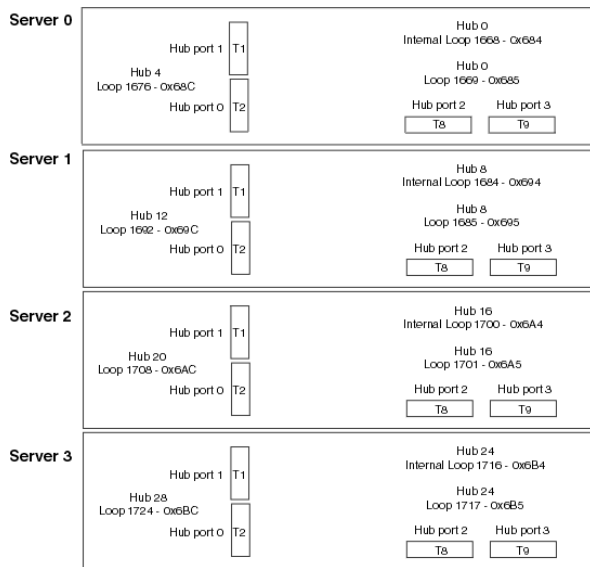
For clarity, the location information is provided as text (in the following table) and as a [graphic diagram](#).

Table 3. Model ESCALA PL 850R/PL 1650R/R+ SIIODP RIO loop location information

| System unit | Hub (decimal) | Hub loop | Loop number | Location code for leading port of the loop |
|-------------|---------------|----------|-------------|--------------------------------------------|
| 0           | 0             | First    | 1668        | Internal (top unit)                        |
| 0           | 0             | Second   | 1669        | P1-T12 (top unit)                          |
| 0           | 4             | First    | 1676        | P1_C6-T2 (top unit)                        |
| 1           | 8             | First    | 1684        | Internal (second unit*)                    |
| 1           | 8             | Second   | 1685        | P1-T8 (second unit*)                       |
| 1           | 12            | First    | 1692        | P1-C7-T2 (second unit*)                    |
| 2           | 16            | First    | 1700        | Internal (third unit*)                     |
| 2           | 16            | Second   | 1701        | P1-T8 (third unit*)                        |
| 2           | 20            | First    | 1708        | P1-C7-T2 (third unit*)                     |
| 3           | 24            | First    | 1716        | Internal (fourth unit*)                    |
| 3           | 24            | Second   | 1717        | P1-T8 (fourth unit*)                       |
| 3           | 28            | First    | 1724        | P1-C7-T2 (fourth unit*)                    |

\* (The second unit is immediately under the top unit, the third unit is immediately under the second unit, and the fourth unit is immediately under the third unit.)

**Model ESCALA PL 850R/PL 1650R/R+ RIO loop diagram**



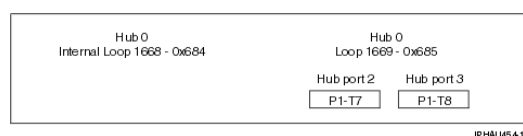
IP1RAU459-0

**Model 5/75**

For clarity, the location information is provided as text (in the following table) and as a [graphic diagram](#).

Table 4. Model 5/75 SIIOADP RIO loop location information

| Hub (decimal) | Hub loop | Loop number | Location code for leading port of the loop |
|---------------|----------|-------------|--------------------------------------------|
| 0             | First    | 1668        | Internal                                   |
| 0             | Second   | 1669        | P1-T7                                      |

**Model 5/75 RIO loop diagram****Models ESCALA PL 3250R and ESCALA PL 6450R**

For clarity, the location information is provided as text (in the following table) and as a [graphic diagram](#).

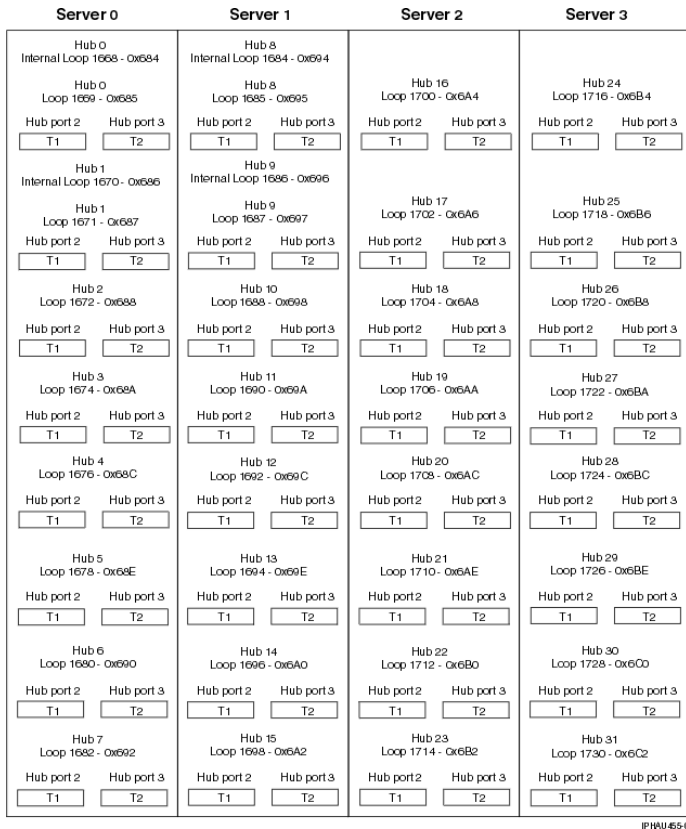
Table 5. Models ESCALA PL 3250R and ESCALA PL 6450R RIO loop SIIOADP location information

| Hub (decimal) | Hub loop | Loop number | Location code for leading port of the loop         |
|---------------|----------|-------------|----------------------------------------------------|
| 0             | First    | 1668        | Internal (with service processor A, leftmost node) |
| 0             | Second   | 1669        | P2-C1-T1                                           |
| 1             | First    | 1670        | Internal                                           |
| 1             | Second   | 1671        | P2-C3-T1                                           |
| 4             | Second   | 1676        | P2-C8-T1                                           |
| 5             | Second   | 1678        | P2-C9-T1                                           |
| 6             | Second   | 1680        | P2-C11-T1                                          |
| 7             | Second   | 1682        | P2-C13-T1                                          |
| 8             | First    | 1684        | Internal (with service processor 'B', second node) |
| 8             | Second   | 1685        | P3-C1-T1                                           |
| 9             | First    | 1686        | Internal                                           |
| 9             | Second   | 1687        | P3-C3-T1                                           |
| 12            | Second   | 1692        | P3-C8-T1                                           |
| 13            | Second   | 1694        | P3-C9-T1                                           |
| 14            | Second   | 1696        | P3-C11-T1                                          |

Service provider information

|    |        |      |                       |
|----|--------|------|-----------------------|
| 15 | Second | 1698 | P3-C13-T1             |
| 16 | Second | 1700 | P4-C1-T1 (third node) |
| 17 | Second | 1702 | P4-C3-T1              |
| 20 | Second | 1708 | P4-C8-T1              |
| 21 | Second | 1710 | P4-C9-T1              |
| 22 | Second | 1712 | P4-C11-T1             |
| 23 | Second | 1714 | P4-C13-T1             |
| 24 | Second | 1716 | P4-C1-T1 (forth node) |
| 25 | Second | 1718 | P4-C3-T1              |
| 28 | Second | 1724 | P4-C8-T1              |
| 29 | Second | 1726 | P4-C9-T1              |
| 30 | Second | 1728 | P4-C11-T1             |
| 31 | Second | 1730 | P4-C13-T1             |

Models ESCALA PL 3250R and ESCALA PL 6450R RIO loop diagram



SI\_PHB

The HSL I/O bridge/RIO adapter hardware in a system or I/O unit is failing.

Follow this procedure to identify the failing component to exchange.

1. Are you working from the serviceable event view and a card location is listed with this FRU?
  - ◆ **Yes:** Then the listed card location is where the error is located. Continue with the next step.

- ◆ **No:** Record the bus number value, **BBBB**, in word 7 of the reference code (see [Breaking down a RIO/HSL or PCI bus reference code](#)). Search for the decimal bus number, using one of the following, to determine which frame or I/O unit contains the failing item.

- ◇ the HMC's system configuration user interface (if an HMC is controlling the system)
- ◇ Hardware Service Manager (HSM)
- ◇ or the System Configuration Listing

Record the unit type or feature and continue with the next step.

2. Use the table below to determine the appropriate service information.

Table 1. SI\_PHB service information

| Unit containing the failing item    | Name of FRU to exchange                                  | Symbolic FRU         | Link to locations information                                                           |
|-------------------------------------|----------------------------------------------------------|----------------------|-----------------------------------------------------------------------------------------|
| ESCALA PL 250T/R                    | System backplane                                         | SI_PHB               | <a href="#">Locations</a> <a href="#">model ESCALA PL 250T/R</a>                        |
| ESCALA PL 450T/R                    | System backplane                                         | SI_PHB               | <a href="#">Locations</a> <a href="#">model ESCALA PL 450T/R</a>                        |
| ESCALA PL 850R/PL 1650R/R+          | I/O backplane on system primary unit or a secondary unit | SI_PHB               | <a href="#">Locations</a> <a href="#">Model ESCALA PL 850R/PL 1650R/R+</a>              |
| ESCALA PL 3250R and ESCALA PL 6450R | Logic planar on the system unit node                     | SI_PHB               | <a href="#">Locations</a> <a href="#">model ESCALA PL 3250R and ESCALA PL 6450R</a>     |
| 50/74, 8079-002, 8093-002           | RIO adapter card                                         | SI_PHB               | <a href="#">Locations</a> <a href="#">50/74, 8079-002, and 8093-002 expansion units</a> |
| 50/79                               | RIO adapter card                                         | SI_PHB               | <a href="#">Locations</a> <a href="#">50/79 expansion unit</a>                          |
| 50/88, 05/88                        | RIO adapter card                                         | SI_PHB               | <a href="#">Locations</a> <a href="#">50/88 and 05/88 expansion units</a>               |
| 50/94, 52/94, 8094-002              | RIO adapter card                                         | SI_PHB               | <a href="#">Locations</a> <a href="#">50/94, 52/94, and 8094-002 expansion units</a>    |
| 50/95, 05/95                        | RIO adapter card                                         | SI_PHB               | <a href="#">Locations</a> <a href="#">50/95 and 05/95 expansion units</a>               |
| Type 1519 external xSeries server   | Integrated xSeries adapter card                          | Follow RIO/HSL cable | <a href="#">Locations</a> <a href="#">Integrated xSeries adapter card (IXA)</a>         |
| 11D/10, 11D/11, and 57/90           | RIO adapter card                                         | SI_PHB               | <a href="#">Locations</a> <a href="#">11D/10, 11D/11, and 57/90 expansion units</a>     |
| 11D/20                              | RIO adapter card                                         | SI_PHB               | <a href="#">Locations</a> <a href="#">11D/20 expansion unit</a>                         |
| 57/91, 57/94, 406/1D                | Backplane 1 (not the riser)                              | SI_PHB               | <a href="#">Locations</a> <a href="#">57/91, 57/94, and 406/1D expansion unit</a>       |
|                                     | Backplane 2 (not the riser)                              | SI_PHB               |                                                                                         |

**This ends the procedure.**

Parent topic: [Symbolic FRUs](#)

## SIRGCBL

This symbolic FRU is not supported on the system.

Continue with the next FRU in the failing item list.

Parent topic: [Symbolic FRUs](#)

---

## SIRGCFG

An invalid configuration was detected on an HSL/RIO loop during IPL.

The four rightmost characters of word 4 in the reference code represent the Program Return Code (PRC), which describes the problem detected. The four leftmost digits of word 7 represent the loop number in hexadecimal format. Convert the loop number to decimal format before comparing it to loop numbers shown in serviceable event views and service tools.

To determine the problem, find the PRC in the table below.

**Note:** The FRU description in the serviceable event view may already contain a message that identifies the problem.

Table 1. Correcting an invalid configuration on an HSL/RIO loop

| PRC       | Problem identified                                    | Corrective action                                                                                                                                                                                                                                                                                                                                                                                                                                         |
|-----------|-------------------------------------------------------|-----------------------------------------------------------------------------------------------------------------------------------------------------------------------------------------------------------------------------------------------------------------------------------------------------------------------------------------------------------------------------------------------------------------------------------------------------------|
| xxxx 0008 | System serial number not set                          | Set the serial number on the system unit. See <a href="#">Accessing the Advanced System Management Interface</a> in the <a href="#">Installing hardware</a> topic. If the problem persists contact your next level of support.                                                                                                                                                                                                                            |
| xxxx 3200 | Clustered system(s) on loop with SPD migrated tower   | Migration towers are not supported; remove them.                                                                                                                                                                                                                                                                                                                                                                                                          |
| xxxx 3201 | Clustered systems on multiple HSL/RIO loops           | Ensure all clustered systems are on the same HSL/RIO loop.                                                                                                                                                                                                                                                                                                                                                                                                |
| xxxx 3202 | Multiple SPD migrated towers detected                 | Migration towers are not supported; remove them.                                                                                                                                                                                                                                                                                                                                                                                                          |
| xxxx 3207 | SPD migrated tower not on first HSL/RIO loop          | Migration towers are not supported; remove them.                                                                                                                                                                                                                                                                                                                                                                                                          |
| xxxx 3212 | NIC/RIO controller level does not support OptiConnect | The NIC/RIO controller hardware component does not support HSL OptiConnect. The FRU containing the NIC/RIO controller component must be upgraded to a level that supports HSL OptiConnect. Examine the Service Action Log (SAL) of the model system on this loop for the same error. The SAL will call out the correct FRU to replace. Use the service tools and information for that system to correct the problem and close the problem on this system. |

**This ends the procedure.**

Parent topic: [Symbolic FRUs](#)

---

## SIRSTAT

A status indication for a RIO loop is identified in the reference code.

Use the table below to determine if the status indication requires a service action. Record the rightmost four characters of word 4 of the reference code. These characters are the program return code (PRC), which indicates the RIO status. The leftmost four characters of word 7 indicate the RIO loop number (in hexadecimal format).

Table 1. Status indicated by the PRC

| PRC  | Indicated status                                                                                                                                                                                                                                                                                                                                                                                                                                                                                                                                                                                                                                                                                                                                                                                                                                                                                                                                                                                                                                                                                                                                                                                                                                                                                                                                                                                                                                                                                                                                                                                                                                                                        |
|------|-----------------------------------------------------------------------------------------------------------------------------------------------------------------------------------------------------------------------------------------------------------------------------------------------------------------------------------------------------------------------------------------------------------------------------------------------------------------------------------------------------------------------------------------------------------------------------------------------------------------------------------------------------------------------------------------------------------------------------------------------------------------------------------------------------------------------------------------------------------------------------------------------------------------------------------------------------------------------------------------------------------------------------------------------------------------------------------------------------------------------------------------------------------------------------------------------------------------------------------------------------------------------------------------------------------------------------------------------------------------------------------------------------------------------------------------------------------------------------------------------------------------------------------------------------------------------------------------------------------------------------------------------------------------------------------------|
| 3204 | <p>A RIO error was detected, indicating that a RIO link failed.</p> <ol style="list-style-type: none"> <li>To diagnose the error read through the transport manager flight recorder.</li> <li>Check the failing link. If the link shows not to have failed, check the devices connected to either end of the link.</li> </ol>                                                                                                                                                                                                                                                                                                                                                                                                                                                                                                                                                                                                                                                                                                                                                                                                                                                                                                                                                                                                                                                                                                                                                                                                                                                                                                                                                           |
| 3205 | <p>During IPL, LIC determined that the loop was not complete.</p> <ul style="list-style-type: none"> <li>This is expected if there are no I/O units on the loop.</li> <li>This error can also occur when an I/O unit, shared I/O unit, or another system on the loop did not complete powering on by the time this system's LIC checked the loop for completeness. As a result, you may see this error in the serviceable event view you are working with.</li> <li>When you find the same reference code logged from the same IPL against the same resource with a PRC of 3206 or 3208, the problem no longer exists. This can happen because the error was recovered when RIO hardware came on line, was properly configured, or the diagnostic code determined that there was not a problem based on the combination of machine types, features, configuration, and topology. In this case, you may close the problem entry.</li> <li>In , this error may also appear in the serviceable event view if any I/O units were removed from the loop without deleting the RIO I/O bridge resources of those units from Hardware Service Manager (HSM). The service procedure identified with the reference code that sent you here will help you determine if the loop is functioning correctly or if service is required.</li> <li>This error may also be caused by a problem in a rack, frame, or unit connected to the RIO loop if the problem prevents the unit from powering on or being detected by LIC. Follow the service procedures for this reference code. When necessary, you may be directed to work on other reference codes before returning to this procedure.</li> </ul> |
| 3206 | During normal operation an RIO loop recovered its redundant path. The loop is now complete.                                                                                                                                                                                                                                                                                                                                                                                                                                                                                                                                                                                                                                                                                                                                                                                                                                                                                                                                                                                                                                                                                                                                                                                                                                                                                                                                                                                                                                                                                                                                                                                             |
| 3208 | During normal operation an RIO I/O bridge recovered a failed link on the loop.                                                                                                                                                                                                                                                                                                                                                                                                                                                                                                                                                                                                                                                                                                                                                                                                                                                                                                                                                                                                                                                                                                                                                                                                                                                                                                                                                                                                                                                                                                                                                                                                          |
| 3209 | See <a href="#">Indicated status for PRC 3209</a> below.                                                                                                                                                                                                                                                                                                                                                                                                                                                                                                                                                                                                                                                                                                                                                                                                                                                                                                                                                                                                                                                                                                                                                                                                                                                                                                                                                                                                                                                                                                                                                                                                                                |
| 3210 | <p>An RIO link switched to a slower speed. The link is designed to run at a faster speed based on the link's hardware and LIC levels at both ends. If there is a FRU list in the serviceable event view, use it to complete the repair action. If not, perform the following sections of this procedure below:</p> <ol style="list-style-type: none"> <li><a href="#">Determining the RIO port label</a></li> <li><a href="#">Replacing the link's failing end point FRUs</a> (replace only the "From Frame ID" end point FRU)</li> </ol>                                                                                                                                                                                                                                                                                                                                                                                                                                                                                                                                                                                                                                                                                                                                                                                                                                                                                                                                                                                                                                                                                                                                               |

### Indicated status for PRC 3209

Recoverable CRC (cyclical redundancy check) errors have occurred on the loop. This error requires service action. An RIO cable or connection must be exchanged. Exchange only the cable that appears in the FRU list of this reference code in this document. If you are working from the serviceable event view, then only the FRU(s) required for this error will be displayed.

Choose from the following scenarios:

- If there is a serviceable event view entry with a cable FRU listed with a loop number, enclosure/unit ID, and port label identified with the cable FRU, then perform one of the following:
  - ◆ If the cable is optical, it is possible the optical connections need cleaning. You can choose either to clean the cable connections at each end without exchanging the cable, or to exchange the cable. Use symbolic FRU `OPT_CLN` for information on cleaning the connections. See [Exchanging RIO cables](#) to exchange the cable.
  - ◆ If the cable is copper, examine the screws that hold the connector at the end of the cable identified in the reference code or the first cable location listed in the serviceable event view entry. It is possible to get CRC errors when the connector screws are not tight. You can choose to tighten the cable connector screws without exchanging the cable only if they are loose. Otherwise, you must exchange the cable (see [Exchanging RIO cables](#)).
  - ◆ If neither of these actions resolves the problem, replace the FRUs in the serviceable event view one at a time. See [Finding part locations](#) for the model or unit you are working on.

**This ends the procedure.**

- If the serviceable event view entry does not list any cable FRUs, then exchange the failing items listed in the serviceable event view entry by following the normal service procedures for those FRUs. This will be the case when the RIO connection is embedded. See [Finding part locations](#) for the model or unit you're working on.

**This ends the procedure.**

- If the serviceable event view entry has cable FRU(s) listed, but the loop number, enclosure/unit ID, and port label are not all listed with the cable FRU, go to [Determining the RIO port label](#) below.

## Determining the RIO port label

Retrieve and record the following information:

- **Loop number.** The loop number is displayed in hexadecimal format as the four leftmost digits of word 7 in the reference code. Convert the loop number to decimal format using [DSA translation](#). Record both the hexadecimal and decimal formats of the loop number. If the loop is an internal loop on an ESCALA PL 250T/R or ESCALA PL 850R/PL 1650R/R+ (loops 0680, 0683, 0686, 0689 hexadecimal or 1664, 1667, 1670, 1673 decimal), then record "Internal".
- **Frame ID.** The frame ID is displayed in hexadecimal format as the four leftmost digits of word 5 of the reference code. You must convert the frame ID to decimal format to match what is displayed in user interfaces and problem views. Record both the hexadecimal and decimal formats of the frame ID. If the frame ID is not zero, then translate the frame ID into the correct machine type, model, and serial number by performing the following:
  1. Log on to SST/DST.

**Attention:** Do not IPL to DST.

2. Select Hardware Service Manager.
3. Select Packaging resources.
4. Selecting Display details for each unit listed until the frame ID matches the ID you are working with. Once you find the matching frame ID, record the unit's machine type, model, and serial number.

**Note:** The frame has an ID of 0000 at this point in the procedure. A frame ID of zero is indicating the NIC/RIO controller in a system unit.

- **Port number indicator.** The port number indicator is the four rightmost digits of word 5 of the reference code.

Use the frame ID and port number indicator in the following table to determine the RIO port label. If you are referred to [Converting the loop number to NIC port location labels](#), the failing item is in a system unit. You will need the RIO loop number to determine the FRU.

Service provider information

The following tables provide hub, port, and location code information for each of the currently supported models. This data is used to determine which RIO loop to use for the B7006981. The asterisk in the "Port indicator number" column indicates the leading port of the port pair.

Table 2. Determining which RIO port label to use on a 520 and ESCALA PL 450T/R

| Model number     | Loop number | Hub | Port indicator number | Location code |                                             |
|------------------|-------------|-----|-----------------------|---------------|---------------------------------------------|
| ESCALA PL 250T/R | 1668        | 0   | 0*                    | "Internal"    |                                             |
|                  |             |     | 1                     | "Internal"    |                                             |
|                  | 1669        |     | 2*                    | P1-T4         |                                             |
|                  |             |     | 3                     | P1-T3         |                                             |
| ESCALA PL 450T/R | 1668        | 0   | 0*                    | "Internal"    |                                             |
|                  |             |     | 1                     | "Internal"    |                                             |
|                  |             |     | 1669                  | 2*            | P1-T12                                      |
|                  | 3           |     |                       | P1-T11        |                                             |
|                  | 1676        |     | 4                     | 0             | P1-C6-T2 (In an expansion card not-onboard) |
|                  |             |     |                       | 1             | P1-C6-T1 (In an expansion card not-onboard) |

Table 3. Determining which RIO port label to use on an ESCALA PL 850R/PL 1650R/R+

| Model number               | Loop number | CEC | Hub | Port indicator number | Location code            |
|----------------------------|-------------|-----|-----|-----------------------|--------------------------|
| ESCALA PL 850R/PL 1650R/R+ | 1668        | 0   | 0   | 0*                    | "Internal" (Top CEC)     |
|                            |             |     |     | 1                     | "Internal"               |
|                            | 1669        | 0   | 0   | 2*                    | P1-T8                    |
|                            |             |     |     | 3                     | P1-T9                    |
|                            | 1676        | 0   | 4   | 0*                    | P1-C7-T2                 |
|                            |             |     |     | 1                     | P1-C7-T1                 |
| ESCALA PL 850R/PL 1650R/R+ | 1684        | 1   | 8   | 0*                    | "Internal" (Second down) |
|                            |             |     |     | 1                     | "Internal"               |
|                            | 1685        | 1   | 8   | 2*                    | P1-T8                    |
|                            |             |     |     | 3                     | P1-T9                    |
|                            | 1692        | 1   | 12  | 0                     | P1-C7-T2                 |
|                            |             |     |     | 1                     | P1-C7-T1                 |
| ESCALA PL 850R/PL 1650R/R+ | 1700        | 2   | 16  | 0*                    | "Internal" (Third down)  |
|                            |             |     |     | 1                     | "Internal"               |
|                            | 1701        | 2   | 16  | 2*                    | P1-T8                    |
|                            |             |     |     | 3                     | P1-T9                    |
|                            | 1708        | 2   | 20  | 0                     | P1-C7-T2                 |
|                            |             |     |     | 1                     | P1-C7-T1                 |
| ESCALA PL 850R/PL 1650R/R+ | 1716        | 3   | 24  | 0*                    | "Internal" (Fourth down) |
|                            |             |     |     | 1                     | "Internal"               |
|                            | 1717        | 3   | 24  | 2*                    | P1-T8                    |
|                            |             |     |     | 3                     | P1-T9                    |
|                            | 1724        | 3   | 28  | 0                     | P1-C7-T2                 |
|                            |             |     |     | 1                     | P1-C7-T1                 |



Table 4. Determining which RIO port label to use on a 575

| Model number | Loop number | Hub | Port indicator number | Location code |
|--------------|-------------|-----|-----------------------|---------------|
| 5/75         | 1668        | 0   | 0*                    | "Internal"    |
|              |             |     | 1                     | "Internal"    |
|              | 1669        |     | 2*                    | P1-T7         |
|              | 3           |     | P1-T8                 |               |

Table 5. Determining which RIO port label to use on an ESCALA PL 3250R and ESCALA PL 6450R

| Model number            | Loop number | Hub | Port indicator number | Location code                         |
|-------------------------|-------------|-----|-----------------------|---------------------------------------|
| ESCALA PL 3250R / 05/95 | 1668        | 0   | 0*                    | "Internal" FSPA                       |
|                         |             |     | 1                     | "Internal"                            |
|                         | 1669        | 0   | 2*                    | P1-C1-T1                              |
|                         |             |     | 3                     | P1-C1-T2                              |
|                         | 1670        | 1   | 0*                    | "Internal" FSPB                       |
|                         |             |     | 1                     | "Internal"                            |
|                         | 1671        | 1   | 2*                    | P1-C3-T1                              |
|                         |             |     | 3                     | P1-C3-T2                              |
|                         | 1672        | 2   | 2*                    | P1-C5-T1                              |
|                         |             |     | 3                     | P1-C5-T2                              |
|                         | 1674        | 3   | 2*                    | P1-C6-T1                              |
|                         |             |     | 3                     | P1-C6-T2                              |
|                         | 1676        | 4   | 2*                    | P1-C8-T1                              |
|                         |             |     | 3                     | P1-C8-T2                              |
|                         | 1678        | 5   | 2*                    | P1-C9-T1                              |
|                         |             |     | 3                     | P1-C9-T2                              |
|                         | 1680        | 6   | 2*                    | P1-C11-T1                             |
|                         |             |     | 3                     | P1-C11-T2                             |
| 1682                    | 7           | 2*  | P1-C13-T1             |                                       |
|                         |             | 3   | P1-C13-T2             |                                       |
| ESCALA PL 3250R / 05/95 | 1684        | 8   | 0*                    | "Internal" FSB (Second node position) |
|                         |             |     | 1                     | "Internal"                            |
|                         | 1685        | 8   | 2*                    | P1-C1-T1                              |
|                         |             |     | 3                     | P1-C1-T2                              |
|                         | 1686        | 9   | 0*                    | "Internal" FSPA                       |
|                         |             |     | 1                     | "Internal"                            |
|                         | 1687        | 9   | 2*                    | P2-C3-T1                              |
|                         |             |     | 3                     | P2-C3-T1                              |
|                         | 1688        | 10  | 2*                    | P2-C5-T1 (Optional card, no HSL)      |
|                         |             |     | 3                     | P2-C5-T2                              |
|                         | 1690        | 11  | 2*                    | P2-C6-T1 (Required empty airflow)     |
|                         |             |     | 3                     | P2-C6-T2                              |

Service provider information

|                         |      |    |           |                           |
|-------------------------|------|----|-----------|---------------------------|
|                         | 1692 | 12 | 2*        | P2-C8-T1                  |
|                         |      |    | 3         | P2-C8-T2                  |
|                         | 1694 | 13 | 2*        | P2-C9-T1                  |
|                         |      |    | 3         | P2-C9-T2                  |
|                         | 1696 | 14 | 2*        | P2-C11-T1                 |
|                         |      |    | 3         | P2-C11-T2                 |
|                         | 1698 | 15 | 2*        | P2-C13-T1                 |
|                         |      |    | 3         | P2-C13-T2                 |
| ESCALA PL 3250R / 05/95 | 1700 | 16 | 2*        | P3-C1-T1 (Third position) |
|                         |      |    | 3         | P3-C1-T2                  |
|                         | 1702 | 17 | 2*        | P3-C3-T1                  |
|                         |      |    | 3         | P3-C3-T2                  |
|                         | 1704 | 18 | 2*        | P3-C5-T1                  |
|                         |      |    | 3         | P3-C5-T2                  |
|                         | 1706 | 19 | 2*        | P3-C6-T1                  |
|                         |      |    | 3         | P3-C6-T2                  |
|                         | 1708 | 20 | 2*        | P3-C8-T1                  |
|                         |      |    | 3         | P3-C8-T2                  |
|                         | 1710 | 21 | 2*        | P3-C9-T1                  |
|                         |      |    | 3         | P3-C9-T2                  |
|                         | 1712 | 22 | 2*        | P3-C11-T1                 |
|                         |      |    | 3         | P3-C11-T2                 |
| 1714                    | 23   | 2* | P3-C13-T1 |                           |
|                         |      | 3  | P3-C13-T2 |                           |
| ESCALA PL 3250R / 05/95 | 1716 | 24 | 2*        | P4-C1-T1                  |
|                         |      |    | 3         | P4-C1-T2                  |
|                         | 1718 | 25 | 2*        | P4-C3-T1                  |
|                         |      |    | 3         | P4-C3-T2                  |
|                         | 1720 | 26 | 2*        | P4-C5-T1                  |
|                         |      |    | 3         | P4-C5-T2                  |
|                         | 1722 | 27 | 2*        | P4-C6-T1                  |
|                         |      |    | 3         | P4-C6-T2                  |
|                         | 1724 | 28 | 2*        | P4-C8-T1                  |
|                         |      |    | 3         | P4-C8-T2                  |
|                         | 1726 | 29 | 2*        | P4-C9-T1                  |
|                         |      |    | 3         | P4-C9-T2                  |
|                         | 1728 | 30 | 2*        | P4-C131-T1                |
|                         |      |    | 3         | P4-C11-T2                 |
| 1730                    | 31   | 2* | P4-C13-T1 |                           |
|                         |      | 3  | P4-C13-T2 |                           |

**Note:** For ESCALA PL 850R/PL 1650R/R+, exchange the FRU on the correct unit (primary or secondary) by matching the serial number (if available in the FRU list on the serviceable event view) or by matching the loop number to the correct unit using [Converting the loop number to NIC port location labels](#).

## Determining if the cable is the cause of the problem

If there is a cable attached to the failing port:

- If the cable is optical, it is possible the optical connections need cleaning. You can choose either to clean the cable connections at each end without exchanging the cable, or to exchange the cable. Use symbolic FRU [OPT\\_CLN](#) for information on cleaning the connections. See [Exchanging RIO cables](#) to exchange the cable.
- If the cable is copper, examine the screws that hold the connector at the end of the cable identified in the reference code or the first cable location listed in the serviceable event view entry. It is possible to get CRC errors when the connector screws are not tight. You can choose to tighten the cable connector screws without exchanging the cable only if they are loose. Otherwise, you must exchange the cable (see [Exchanging RIO cables](#)).
- If neither of these actions resolves the problem, replace the cable. Perform [RIOIP08](#) to determine the frame ID and RIO port label of the other end of the cable you will be exchanging (if you do not already know). Does this correct the problem?
  - ◆ **Yes: This ends the procedure.**
  - ◆ **No:** Continue with replacing the FRUs that the cable is connected to, starting with the FRU listed first.

## Replacing the link's failing end point FRUs

Use the following table to determine the end point FRUs on the "From Frame ID" port. Replace the FRUs one at a time.

If replacing the end point FRUs for the "From Frame ID" port does not resolve the error, use the table below to replace the end point FRUs at the other end of the cable. Perform [RIOIP08](#) to determine the system or I/O unit frame ID and RIO port label of the other end of the cable (if you do not already know).

Table 6. End point FRUs

| Model                                                    | Loop number<br>(hexadecimal / decimal) | End point FRUs                                                                                                                                                                                                                                                                                                                                                                                                                            |
|----------------------------------------------------------|----------------------------------------|-------------------------------------------------------------------------------------------------------------------------------------------------------------------------------------------------------------------------------------------------------------------------------------------------------------------------------------------------------------------------------------------------------------------------------------------|
| ESCALA PL<br>250T/R,<br>ESCALA PL<br>850R/PL<br>1650R/R+ | 0680 / 1664                            | The loop is embedded in the system unit planar. Exchange the system unit planar using symbolic FRU <a href="#">SYSBKPL</a> .                                                                                                                                                                                                                                                                                                              |
| ESCALA PL<br>250T/R,<br>ESCALA PL<br>850R/PL<br>1650R/R+ | 0681 / 1665                            | For all port number values, the loop's NIC/RIO controller is embedded in the system unit planar. Exchange the system unit planar using symbolic FRU <a href="#">SYSBKPL</a> .                                                                                                                                                                                                                                                             |
| ESCALA PL<br>850R/PL<br>1650R/R+                         | 0682 / 1666                            | For all port number values, the loop's NIC/RIO controller is in the NIC/RIO controller card. Exchange the NIC/RIO controller using symbolic FRU <a href="#">SICNTRL</a> .                                                                                                                                                                                                                                                                 |
| ESCALA PL<br>850R/PL<br>1650R/R+                         | 0683 / 16670686 /<br>16700689 / 1673   | The loop is embedded in the system unit planar. Exchange the system unit planar using symbolic FRU <a href="#">SYSBKPL</a> .<br><br><b>Note:</b> Exchange the FRU on the correct unit (primary or secondary) by matching the serial number (if available in the FRU list on the serviceable event view) or by matching the loop number to the correct unit using <a href="#">Converting the loop number to NIC port location labels</a> . |

**This ends the procedure.**

Parent topic: [Symbolic FRUs](#)

---

## SLOTERR

The multi-adapter bridge detected a problem with a card location that it controls.

The problem is in the controls for the card slot. The card location may or may not have an installed card. If there is a card installed in that location, it may be the source of the problem. In some cases, the user interface view of the serviceable event will list more than one card position for this FRU's location. The problem may be with any one of the FRU's in those locations. When there is a list of locations in this FRU's location code, the card locations will be separated by commas. A range of card positions will show the starting card position, a colon, and the ending card position.

**Note:** Any IOPs plugged into slots owned by a Linux partition will not power on. This error will be logged. Correct the situation by removing the IOP cards.

1. Is there a single card position listed in the serviceable event user interface of an operating system, service processor, or the HMC for this failing item?
  - ◆ **No:** Continue with the next step.
  - ◆ **Yes:** Go to step 5.
2. Is there a range of card positions (PCI bridge set) listed in the problem view for this failing item?
  - ◆ **No:** Continue with the next step.
  - ◆ **Yes:** LIC could not identify the slot with the error. Perform [MABIP03](#) to determine the card position with the failure.

**This ends the procedure.**

3. Record the Direct Select Address (DSA), which is word 7 of the reference code from the problem view display.
4. Examine the multi-adapter bridge function number in the DSA (see [DSA translation](#)). Is the multi-adapter bridge function number less than or equal to 7?
  - ◆ **Yes:** Go to [MABIP53](#) to locate the card, and then continue with the next step.
  - ◆ **No:** LIC could not identify the slot with the error. Perform [MABIP03](#) to determine the card position with the failure.

**This ends the procedure.**

5. Does the reference code that sent you here appear more than once, or does another reference code with this symbolic FRU appear from the same IPL and against the same resource?
  - ◆ **Yes:** The failure is at the multi-adapter bridge. Do not use this symbolic FRU; instead, go to the next failing item in the list.

**This ends the procedure.**

- ◆ **No:** Locate the message in the following table to determine the problem and necessary corrective action.

Table 1. Card slot errors

| Problem or message                                          | Meaning or corrective action                                                                                                                                                                                                                                                                                                                                                                                                                                                                                                 |
|-------------------------------------------------------------|------------------------------------------------------------------------------------------------------------------------------------------------------------------------------------------------------------------------------------------------------------------------------------------------------------------------------------------------------------------------------------------------------------------------------------------------------------------------------------------------------------------------------|
| Slot unavailable due to 64-bit card in adjacent slot.       | <p>The card location specified in the DSA is unavailable for the card installed there. Do not use that card location.</p> <p>The card location with a multi-adapter bridge function number one less than the multi-adapter bridge function number in the DSA has a 64-bit card installed. The 64-bit card is using the 32-bit PCI bus of the card location specified in the DSA.</p> <p>To determine the multi-adapter bridge function numbers and the card locations they specify, see <a href="#">DSA translation</a>.</p> |
| LED control failure, do not use slot.                       | System code has detected a problem with the controls for the LED at the card location specified by the DSA. Do not use that card location.                                                                                                                                                                                                                                                                                                                                                                                   |
| Power control failure, do not use slot.                     | System code has detected a problem with the power controls at the card location specified by the DSA. Do not use that card location.                                                                                                                                                                                                                                                                                                                                                                                         |
| Multi-adapter bridge card slot error, do not use card slot. | System code has detected a problem with the controls at the card location specified by the DSA. Do not use that card location.                                                                                                                                                                                                                                                                                                                                                                                               |

**This ends the procedure.**

Parent topic: [Symbolic FRUs](#)

---

## SLOTUSE

The card in the given slot is not available for use.

1. Is the unit reference code 2250 or 2300?
  - ◆ **No:** Continue with step 3.
  - ◆ **Yes:** The first two characters in word 4 of the reference code will identify the platform LIC component that has control of the slot. Continue with the next step.
2. What is the value of the first two characters of word 4 of the reference code?
  - ◆ **81:** The component that has control of the slot is concurrent maintenance. The concurrent maintenance procedure must complete before the partition will IPL. **This ends the procedure.**
  - ◆ **02 or 03:** The component that has control of the slot is HMC service or HMC configuration. Make sure that HMC functions are not using the slot. **This ends the procedure.**
  - ◆ **Other:** Contact your next level of support. **This ends the procedure.**
3. Is the unit reference code 2475?
  - ◆ **No:** Contact your next level of support. **This ends the procedure.**
  - ◆ **Yes:** Continue with the next step.
4. Look in the serviceable event view for part numbers and location codes associated with the card slot.

**Note:** There will not be a part number if the card slot is empty.

If the reference code is on the control panel, look in the FRU callout section of the reference code for the location of the card slot. Use the [location information](#) to see if a card is physically present in the card slot. Is a card physically present?

- ◆ **Yes:** Exchange the failing card. **This ends the procedure.**
- ◆ **No:** Use symbolic FRU [LPARCFG](#) to reconfigure the card slot so that it is not a required resource to IPL the partition. **This ends the procedure.**

Parent topic: [Symbolic FRUs](#)

---

## SNSDATA

Look here for information about SNSDATA symbolic FRU.

This is a portion of the SCSI sense data associated with the unit reference code (URC); it is not a failing item in and of itself. This data is referenced by certain failure isolation procedures within the [All 3995 Publications and Documentation](#) Web site or the 3996 Maintenance Information shipped with the 3996 Optical Library.

**Parent topic:** [Symbolic FRUs](#)

---

## SPBUS

The path to the service processor may be the failing item.

Look in the serviceable event view. Fix all B700 697x errors that occurred at approximately the same time. One of them will implicate the hardware that communicates with the service processor.

**This ends the procedure.**

**Parent topic:** [Symbolic FRUs](#)

---

## SPNETWK

A connection between an HMC and either a service processor or BPC has been lost. The location code will identify the unit to which contact was lost.

1. Is the system receiving power?
  - ◆ **Yes:** Continue with the next step.
  - ◆ **No:** Take the necessary action to restore power to the system. **This ends the procedure.**
2. Verify the system's connections to the HMC by choosing one of the following:
  - ◆ **If you are working on a model ESCALA PL 3250R or ESCALA PL 6450R,** verify that the cables listed below are seated and functioning properly at both ends. See [Locations models ESCALA PL 3250R and ESCALA PL 6450R](#) for diagrams and port location information, and [Model ESCALA PL 3250R and ESCALA PL 6450R cables](#) should you need to replace one of the cables.
    - ◇ BPC A (front) port J00A to the HMC.
    - ◇ BPC A (front) port J00B to service processor 2 (on the right) port J03.
    - ◇ BPC A (front) port J00C to service processor 1 (on the right) port J03.
    - ◇ BPC B (back) port J00A to the redundant HMC (if applicable).

**Note:** BPC B must not be connected to the same HMC as BPC A.

- ◇ BPC B (back) port J00B to service processor 2 (on the right) port J04.
  - ◇ BPC B (back) port J00C to service processor 1 (on the right) port J04.
  - ◆ **If you are working on any other model,** verify the network connection between the service processor and the HMC. See [Finding part locations](#) for diagrams and port location information.
- Does the problem persist?
- ◆ **Yes:** Continue with the next step.
  - ◆ **No: This ends the procedure.**
3. Shut down the operating system for the server in preparation to reboot the server.

**Note:** If the server is a , ESCALA PL 3250R, or ESCALA PL 6450R you must first shut down the server and then remove the power by using the UEPO switch on the frame. Removing the power by using the UEPO switch (for these models) causes the BPC to also request a new IP address from the DHCP server when the server reboots.

Reapply the power and boot the server. Does the problem persist?

- ◆ **Yes:** Continue with the next step.
  - ◆ **No: This ends the procedure.**
4. Use [SVCPROC](#) to replace the service processor. If the problem persists, contact your next level of support.

**Note:** If the server is a model , ESCALA PL 3250R, or ESCALA PL 6450R contact your next level of support before replacing the service processor.

**This ends the procedure.**

Parent topic: [Symbolic FRUs](#)

---

## SPNLCRD

This symbolic FRU is no longer supported.

Parent topic: [Symbolic FRUs](#)

---

## SRCTB1X

There is a failure detected by the power subsystem.

The complete FRU part number, procedure ID, or symbolic FRU could not be determined by the power subsystem firmware. This FRU in the serviceable event view may have a partial or complete location code that will assist you in the repair action. Go to [\(1xxx\) System power control network \(SPCN\) reference codes](#) and locate the SRC you are working on to service this problem.

Parent topic: [Symbolic FRUs](#)

---

## STORIOA

Replace the storage I/O adapter.

Use the I/O adapter location information in the Service Action Log if it is available. If the location is not available, find the address of the I/O adapter (see [System reference code \(SRC\) address formats](#)). Use the address to find the location (see [Finding part locations](#)).

Parent topic: [Symbolic FRUs](#)

---

## SVCDPCS

Look here for information about SVCDPCS symbolic FRU.

This symbolic FRU means that the service action is to read the description of the system reference code (SRC) in the list of system reference codes and perform any actions indicated there.

If you linked to this FRU from the SRC description in the list of system reference codes, then go back to the SRC description. Otherwise, see [List of system reference codes](#) and locate the SRC you are working on.

Perform any actions indicated there.

Parent topic: [Symbolic FRUs](#)

## SVCPROC

The service processor is failing.

After you have replaced the part, set the configuration ID for SPCN before powering up, otherwise the machine will not IPL. For more information, see [Changing the processing unit identifier](#).

Use the table below to identify your machine type, model, and FRU, then click the associated link to find the service information for the specified FRU.

### For B1xx SRCs:

To determine which service processor to replace on a model ESCALA PL 1650R-L+, ESCALA PL 850R/PL 1650R/R+, ESCALA PL 3250R, or ESCALA PL 6450R, use the last byte in word 3 of the primary SRC.

- If the last byte is a 10, then replace the primary unit service processor for model ESCALA PL 1650R-L+ or ESCALA PL 850R/PL 1650R/R+, or service processor 0 for model ESCALA PL 3250R or ESCALA PL 6450R.
- If the last byte is a 20, then replace the secondary unit 1, service processor for model ESCALA PL 1650R-L+ or ESCALA PL 850R/PL 1650R/R+, or service processor 1 for model ESCALA PL 3250R or ESCALA PL 6450R.
- If the last byte is a 30, use one of the following methods to determine which service processor you need to replace:

If you have access to the Advanced System Management Interface (ASMI), log on and display the details of the service processor error log. Using the Platform Event Log id (shown in the first table of each detail of the log), look at the first byte.

- ◆ If the first byte is a 50, then replace the primary unit service processor for model ESCALA PL 1650R-L+ or ESCALA PL 850R/PL 1650R/R+, or service processor 0 for model ESCALA PL 3250R or ESCALA PL 6450R.
- ◆ If the first byte is a 51, then replace the secondary unit 1 service processor for model ESCALA PL 1650R-L+ or ESCALA PL 850R/PL 1650R/R+, or service processor 1 for model ESCALA PL 3250R or ESCALA PL 6450R.

If you have access to an Hardware Management Console (HMC), log in as PE user and bring up Manage Serviceable Events under the Service Focal Point screen. Display the events for the corresponding service processor system, then double-click the system to see the details. Look at the Field Platform log ID, which contains a decimal value that you need to convert to a hexadecimal value.

- ◆ If the first byte of the hexadecimal value is a 50, then replace the primary unit service processor for model ESCALA PL 1650R-L+ or ESCALA PL 850R/PL 1650R/R+, or service processor 0 for model ESCALA PL 3250R or ESCALA PL 6450R.
- ◆ If the first byte of the hexadecimal value is a 51, then replace the secondary unit 1 service processor for model ESCALA PL 1650R-L+ or ESCALA PL 850R/PL 1650R/R+, or service processor 1 for model ESCALA PL 3250R or ESCALA PL 6450R.

| System model | Name of symbolic FRU to locate | FRU name         | Link to locations information |
|--------------|--------------------------------|------------------|-------------------------------|
|              | SVCPROC                        | System backplane |                               |



Service provider information

|                                                         |         |                                                                        |                                                                                                              |
|---------------------------------------------------------|---------|------------------------------------------------------------------------|--------------------------------------------------------------------------------------------------------------|
| ESCALA PL 245T/R                                        |         |                                                                        | <a href="#">Locations</a> <a href="#">model ESCALA PL 245T/R</a>                                             |
| ESCALA PL 250R-VL or ESCALA PL 450R-XS                  | SVCPROC | System backplane                                                       | <a href="#">Locations</a> <a href="#">model ESCALA PL 250R-VL or ESCALA PL 450R-XS</a>                       |
| ESCALA PL 250R-L, PL 250R-L+ or PL 450R-VL+             | SVCPROC | System backplane                                                       | <a href="#">Locations</a> <a href="#">model ESCALA PL 250R-L, ESCALA PL 250R-L+ or ESCALA PL 450R-VL+</a> ,  |
| ESCALA PL 250T/R, PL 250T/R+ or PL 450T/R-L+            | SVCPROC | Service processor card                                                 | <a href="#">Locations</a> <a href="#">Model ESCALA PL 250T/R, ESCALA PL 250T/R+ or ESCALA PL 450T/R-L+</a> , |
| ESCALA PL 450T/R, PL 450T/R+ or PL 850T/R-L+            | SVCPROC | System backplane                                                       | <a href="#">Locations</a> <a href="#">ESCALA PL 450T/R, ESCALA PL 450T/R+ or ESCALA PL 850T/R-L+</a> ,       |
| ESCALA PL 1650R-L+ and ESCALA PL 850R/PL 1650R/R+       | SVCPROC | Primary unit, Service processor<br>Secondary unit 1, Service processor | <a href="#">Locations</a> <a href="#">Model ESCALA PL 1650R-L+ and ESCALA PL 850R/PL 1650R/R+</a>            |
| 5/75                                                    | SVCPROC | System backplane                                                       | <a href="#">Locations</a> <a href="#">model 5/75</a>                                                         |
| ESCALA PL 3250R, PL 3250R+, ESCALA PL 6450 or PL 6450R+ | SVCPROC | Service processor card 0<br>Service processor card 1                   | <a href="#">Locations</a> <a href="#">model ESCALA PL 3250R and ESCALA PL 6450R</a>                          |

**This ends the procedure.**

**Parent topic:** [Symbolic FRUs](#)

## SYSBKP2

The failing component is the system backplane.

Use the table below to identify your machine type, model, and FRU, then click the associated link to find the service information for the specified FRU.

Table 1. Backplane service information

| System model     | Symbolic FRU to find | FRU to exchange  | Link to locations information                                    |
|------------------|----------------------|------------------|------------------------------------------------------------------|
| ESCALA PL 245T/R | SYSBKPL              | System backplane | <a href="#">Locations</a> <a href="#">model ESCALA PL 245T/R</a> |

**Parent topic:** [Symbolic FRUs](#)

## SYSNTWK

There has been a network adapter failure on this HMC.

1. Check the amber port LEDs. Are all of the amber LEDs blinking?
  - ◆ **Yes:** One of the ports is not properly configured. Go to [Configuring the HMC](#). **This ends the procedure.**
  - ◆ **No:** The port with the unlit amber LED is experiencing the problem. Continue with the next step.
2. Ensure that the port is properly defined.
3. Run PC Doctor diagnostics (see [HMC diagnostics overview](#)) to determine which resource is failing, and then replace that failing resource.

**This ends the procedure.**

Parent topic: [Symbolic FRUs](#)

---

## TAPCLN

Clean the tape unit.

Parent topic: [Symbolic FRUs](#)

---

## TAPCNFG

Look here for information about TAPCNFG symbolic FRU.

One of the following configuration problems was detected:

- Tape and disk devices are attached to an I/O processor or IOA that does not support tape and disk devices at the same time.
- An unsupported device type or model is attached.

Correct the configuration problem before exchanging any parts.

Parent topic: [Symbolic FRUs](#)

---

## TOD

This symbolic FRU is no longer supported.

See symbolic FRU [TOD\\_BAT](#) instead.

Parent topic: [Symbolic FRUs](#)

---

## TOD\_BAT

The battery for the time-of-day battery is low or failing.

Use the table below to determine which FRU to replace and how to replace it.

**For B1xx SRCs:**

To determine which Time-of-day (TOD) battery to replace on a model ESCALA PL 850R/PL 1650R/R+, ESCALA PL 3250R, or ESCALA PL 6450R, use the last byte in word 3 of the primary SRC.

- If the last byte is a 10, then replace the TOD battery on the primary unit, service processor for model ESCALA PL 850R/PL 1650R/R+ or service processor 0 for model ESCALA PL 3250R or ESCALA PL 6450R.
- If the last byte is a 20, then replace the TOD battery on the secondary unit 1, service processor for model ESCALA PL 850R/PL 1650R/R+ or service processor 1 for model ESCALA PL 3250R or ESCALA PL 6450R.
- If the last byte is a 30, use one of the following methods to determine which TOD battery you need to replace:

If you have access to the Advanced System Management Interface (ASMI), log on and display the details of the service processor error log. Using the Platform Event Log id (shown in the first table of each detail of the log), look at the first byte.

- ◆ If the first byte is a 50, then replace the TOD battery on the primary unit service processor for model ESCALA PL 850R/PL 1650R/R+ or the TOD battery on service processor 0 for model ESCALA PL 3250R or ESCALA PL 6450R.
- ◆ If the first byte is a 51, then replace the TOD battery on the secondary unit 1 service processor for model ESCALA PL 850R/PL 1650R/R+ or the TOD battery on service processor 1 for model ESCALA PL 3250R or ESCALA PL 6450R.

If you have access to an Hardware Management Console (HMC), log in as PE user and bring up Manage Serviceable Events under the Service Focal Point screen. Display the events for the corresponding service processor system, then double-click the system to see the details. Look at the Field Platform log ID, which contains a decimal value that you need to convert to a hexadecimal value.

- ◆ If the first byte of the hexadecimal value is a 50, then replace the TOD battery on the primary unit service processor for model ESCALA PL 850R/PL 1650R/R+ or the TOD battery on service processor 0 for model ESCALA PL 3250R or ESCALA PL 6450R.
- ◆ If the first byte of the hexadecimal value is a 51, then replace the TOD battery on the secondary unit 1 service processor for model ESCALA PL 850R/PL 1650R/R+ or the TOD battery on service processor 1 for model ESCALA PL 3250R or ESCALA PL 6450R.

| System model                           | Name of symbolic FRU to locate | FRU name                                                                               | Link to locations information                                                          |
|----------------------------------------|--------------------------------|----------------------------------------------------------------------------------------|----------------------------------------------------------------------------------------|
| ESCALA PL 250R-VL or ESCALA PL 450R-XS | TOD_BAT                        | Time-of-day (TOD) battery                                                              | <a href="#">Locations</a> <a href="#">model ESCALA PL 250R-VL or ESCALA PL 450R-XS</a> |
| ESCALA PL 250R-L                       | TOD_BAT                        | Time-of-day (TOD) battery                                                              | <a href="#">Locations</a> <a href="#">model ESCALA PL 250R-L</a>                       |
| ESCALA PL 250T/R                       | TOD_BAT                        | Time-of-day (TOD) battery                                                              | <a href="#">Locations</a> <a href="#">Model ESCALA PL 250T/R</a>                       |
| ESCALA PL 450T/R                       | TOD_BAT                        | Time-of-day (TOD) battery                                                              | <a href="#">Locations</a> <a href="#">Model ESCALA PL 450T/R</a>                       |
| ESCALA PL 850R/PL 1650R/R+             | TOD_BAT                        | Primary unit, Time-of-day (TOD) battery<br>Secondary unit 1, Time-of-day (TOD) battery | <a href="#">Locations</a> <a href="#">Model ESCALA PL 850R/PL 1650R/R+</a>             |
| 5/75                                   | TOD_BAT                        | Time-of-day (TOD) battery                                                              | <a href="#">Locations</a> <a href="#">model 5/75</a>                                   |
| ESCALA PL 3250R and ESCALA PL 6450R    | TOD_BAT                        | Service processor card 0<br>Service processor card 1                                   | <a href="#">Locations</a> <a href="#">model ESCALA PL 3250R and ESCALA PL 6450R</a>    |

**This ends the procedure.**

Parent topic: [Symbolic FRUs](#)

---

## TOPORT

The RIO adapter or controller on one end of the link may be the failing item.

If you were sent to this procedure as a result of a B700 6985 SRC, and this is the only FRU in the FRU list, then the following conditions have occurred:

- The system cannot see any I/O units on a RIO loop
- At least one cable is attached to a port on that loop

In this case, go to [\(A7xx, B7xx\) Licensed Internal Code \(LIC\) Reference Codes](#) and work from the full FRU list provided there.

**Note:** The other end of the link may be given in the symbolic FRU [FRPORT](#).

**Note:** For this procedure, the terms "HSL I/O bridge" and "RIO adapter" are interchangeable.

1. Record the bus number (BBBB) in word 7 of the reference code (see [Breaking down a RIO/HSL or PCI bus reference code](#)).
2. Use one of the following procedures to find the failing RIO adapter:
  - ◆ [Finding the failing RIO adapter using AIX or Linux](#)
  - ◆ [Finding the failing RIO adapter using the HMC](#)

Parent topic: [Symbolic FRUs](#)

### Finding the failing RIO adapter using AIX or Linux

1. Determine which RIO loop the failing adapter is on (see [Converting the loop number to NIC port location labels](#)).
2. Identify each unit in the loop by following the cable.
3. Power down the system and remove all expansion units in the loop that starts and ends at the ports given in the previous step. If there is a base I/O unit on that loop, leave only that unit connected to the system unit.
4. Power on the system to partition standby and check for the same SRC that sent you here. Did the SRC reoccur?
  - ◆ **No:** Power down the system and add the next unit in the original loop. Repeat step 3.
  - ◆ **Yes:** The RIO adapter in the last I/O unit added is possibly the failing item. Use the RIO adapter information in the locations tables for the unit with the possible failing RIO adapter and go to [Finding part locations](#). Select the model or expansion unit you are working with, and find the location in the locations tables to determine the replacement procedure and physical location of the FRU. **This ends the procedure.**

### Finding the failing RIO adapter using the HMC

1. Select the Service Utilities task.
2. In the Service Utilities window, click the system you are working on. Then, from the selected drop down menu, select View RIO Topology .
3. In the Current Topology area, scroll down until you find data for the RIO loop number with which you are working.

- Each line in that RIO loop represents a RIO adapter. Find the first one with a trailing port status of *failed*. Use that adapter information, and go to [Finding part locations](#). Select the model or expansion unit with which you are working, and find the location in the locations tables to determine the replacement procedure and physical location of the FRU.

**This ends the procedure.**

## TWRBKPL

The failing item is the tower card in an I/O unit.

- Are you working from the serviceable event view and a card location is listed with this failing item?
  - ◆ **Yes:** Then the listed card location is where the error is located. Continue with the next step.
  - ◆ **No:** Record the bus number value, `BBBB`, in word 7 of the reference code (see [DSA translation](#)). Search for the bus number in the HMC's or operating system's resource and configuration interfaces or the System Configuration Listing to determine which unit contains the failing item. Continue with the next step.
- The failing item is built into the backplane PCI card planar of the I/O unit. Use the table below to determine the appropriate service information.

| I/O unit     | FRU to exchange | Symbolic FRU | Link to locations information                                             |
|--------------|-----------------|--------------|---------------------------------------------------------------------------|
| 50/95, 05/95 | Backplane       | TWRBKPL      | <a href="#">Locations</a> <a href="#">50/95 and 05/95 expansion units</a> |

**This ends the procedure.**

Parent topic: [Symbolic FRUs](#)

## TWRPLNR

The failing component is in the PCI planar board of an I/O unit.

- Are you working from the serviceable event view and a card location is listed with this failing item?
  - ◆ **Yes:** Then the listed card location is where the error is located. Continue with the next step.
  - ◆ **No:** Record the bus number value, `BBBB`, in word 7 of the reference code (see [DSA translation](#)). Search for the bus number in the HMC's or operating system's resource and configuration interfaces or the System Configuration Listing to determine which unit contains the failing item. Record the unit type and model. Continue with the next step.
- Use the table below to determine the appropriate service information.

Table 1. Failing component service information for TWRPLNR

| Unit type                 | Symbolic FRU to locate | FRU name                 | Link to locations information                                                           |
|---------------------------|------------------------|--------------------------|-----------------------------------------------------------------------------------------|
| 50/74, 8079-002, 8093-002 | TWRPLNR                | Expansion unit backplane | <a href="#">Locations</a> <a href="#">50/74, 8079-002, and 8093-002 expansion units</a> |
| 50/79                     | TWRPLNR                |                          |                                                                                         |

Service provider information

|                           |         |                             |                                                      |
|---------------------------|---------|-----------------------------|------------------------------------------------------|
|                           |         | Expansion unit backplane    | Locations 50/79 expansion unit                       |
| 50/88, 05/88              | TWRPLNR | Expansion unit backplane    | Locations 05/88 and 50/88 expansion units            |
| 50/94, 52/94, 8094-002    | TWRPLNR | Expansion unit backplane    | Locations 50/94, 52/94, and 8094-002 expansion units |
| 57/91, 57/94, and 406/1D  | TWRPLNR | Backplane 1 (not the riser) | Locations 57/91, 57/94, and 406/1D expansion units   |
|                           |         | Backplane 2 (not the riser) |                                                      |
| 11D/10, 11D/11, and 57/90 | TWRPLNR | I/O backplane               | Locations 11D/10, 11D/11, and 57/90 expansion units  |
| 11D/20                    | TWRPLNR | Backplane                   | Locations 11D/20 expansion unit                      |

**This ends the procedure.**

Parent topic: [Symbolic FRUs](#)

---

## UC235

The problem may be that the card (a resource) was removed from the card enclosure without updating the system configuration records.

**Note:** If the system has OptiConnect, verify that the remote system was powered on at the time of the failure.

To update the system configuration records select Hardware System Manager > Logical Hardware Resources > System Bus Resources > Non-reporting Resources > Remove.

**This ends the procedure.**

Parent topic: [Symbolic FRUs](#)

---

## UC236

The problem may be that the card (a resource) is not correctly plugged into the card enclosure.

Use the location information associated with this failing component in the Service Action Log entry and verify that the card is installed properly.

Parent topic: [Symbolic FRUs](#)

---

## UG3AS

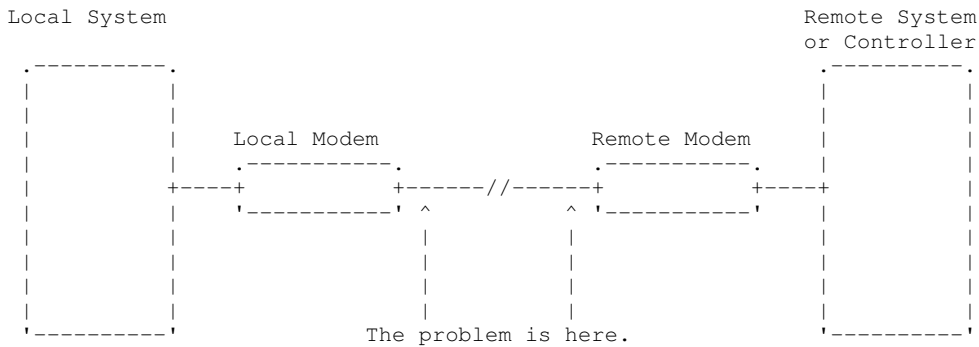
An error has been detected in the licensed internal code.

Contact your next level of support for possible corrective actions.



## UJ0E7

The problem has been isolated to the telephone line equipment that links the local and the remote equipment.

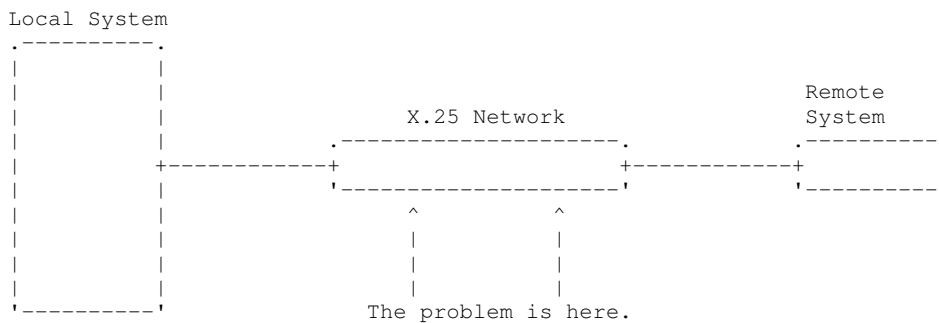


Parent topic: [Symbolic FRUs](#)

---

## UJ0E9

The problem has been isolated to the X.25 network.



Parent topic: [Symbolic FRUs](#)

---

## UJ6P3

An error occurred in the Facsimile Support/400 Licensed Program. Please contact your next level of support for possible corrective actions.

Find additional information on Facsimile Support for in the Application System Facsimile Support for User's Guide.

Parent topic: [Symbolic FRUs](#)

---

## UJ9GC

The configuration for the wireless network has been identified as a cause of the problem.

The following parameters must be the same for the entire network:

- Frequency
- Data rate
- Radio system identifier

The configuration for one or more of the following will need to be changed:

- line description



- Access points
- Remote devices

Parent topic: [Symbolic FRUs](#)

---

## UJA32, UJC38

The communication line or the automatic call unit is already being used.

Perform the following:

1. Use the documentation that came with your automatic call unit to verify that the unit is configured correctly.
2. Make sure that the telephone line attached to your automatic call unit is not being used by another job.

**This ends the procedure.**

Parent topic: [Symbolic FRUs](#)

---

## UJA33, UJP37

The problem can be caused by too many active lines using the same input/output processor (IOP) card or by setting the line speed too high.

Perform the following to find which active lines use the same IOP, and to correct the problem:

1. Vary off the failing line using the `VRFCFG` command.
2. Vary the line on again, with the reset option of the `VRFCFG` command set to Yes. The active lines using that IOP will be displayed with their line speeds.
3. Determine if there are too many lines using the IOP, or if the line speeds are too high.
4. Correct the configuration as needed.

**This ends the procedure.**

Parent topic: [Symbolic FRUs](#)

---

## UJA34

A configuration parameter may be incorrect.

To determine the configuration parameter that was identified as a possible problem, search for the error in the Service Action Log (see [Using the Service Action Log](#)) and display the failing item information for the error. The failing item description associated with this symbolic FRU identifies the parameter that may be the problem.

The line configuration parameter that was identified as a possible problem can be changed by using the `WRKLIND` command. Determine if the suspected configuration parameter is wrong and change if necessary.

Some software problems can be temporarily solved by changing the configuration parameter, even if the original value was correct. Report this problem to your service representative if you use this temporary change.

**Parent topic:** [Symbolic FRUs](#)

---

## UJA35

A configuration parameter may be incorrect.

To determine the configuration parameter that was identified as a possible problem, search for the error in the Service Action Log (see [Using the Service Action Log](#)) and display the failing item information for the error. The failing item description associated with this symbolic FRU identifies the parameter that may be the problem.

The configuration parameter that was identified as a possible problem can be verified by displaying the synchronous data link control (SDLC) controller description with the `DSPCTLD` command.

The controller description was created by the `CRTCTLAPPC`, `CRTCTLFNC`, `CRTCTLHOST`, or `CRTCTLRWS` command. You may need to review the appropriate command information to determine if the configuration parameter is wrong.

Some software problems can be temporarily solved by changing the configuration parameter, even if the original value was correct. Report this problem to your service representative if you use this temporary change.

**Parent topic:** [Symbolic FRUs](#)

---

## UJA36

A configuration parameter may be incorrect.

To determine the configuration parameter that was identified as a possible problem, search for the error in the Service Action Log (see [Using the Service Action Log](#)) and display the failing item information for the error. The failing item description associated with this symbolic FRU identifies the parameter that may be the problem.

The configuration parameter that was identified as a possible problem can be verified by displaying the X.25 line description with the `DSPLIND` command.

The line description was created by the `CRTLINX25` command. You may need to review the appropriate command information to determine if the configuration parameter is wrong.

Some software problems can be temporarily solved by changing the configuration parameter, even if the original value was correct. Report this problem to your service representative if you use this temporary change.

**Parent topic:** [Symbolic FRUs](#)

---

## UJB35

A configuration parameter may be incorrect.

To determine the configuration parameter that was identified as a possible problem, search for the error in the Service Action Log (see [Using the Service Action Log](#)) and display the failing item information for the error. The failing item description associated with this symbolic FRU identifies the parameter that may be the problem.

The configuration parameter that was identified as a possible problem can be verified by displaying the binary synchronous line description with the `DSPLIND` command.

The line description was created by the `CRTLINBSC` command. You may need to review the appropriate command information to determine if the configuration parameter is wrong.

Some software problems can be temporarily solved by changing the configuration parameter, even if the original value was correct. Report this problem to your service representative if you use this temporary change.

**Parent topic:** [Symbolic FRUs](#)

---

## UJB36

A configuration parameter may be incorrect.

To determine the configuration parameter that was identified as a possible problem, search for the error in the Service Action Log (see [Using the Service Action Log](#)) and display the failing item information for the error. The failing item description associated with this symbolic FRU identifies the parameter that may be the problem.

The configuration parameter that was identified as a possible problem can be verified by displaying the binary synchronous control unit description with the `DSPCTLD` command.

The controller description was created by the `CRTCTLBSC` command. You may need to review the appropriate command information to determine if the configuration parameter is wrong.

Some software problems can be temporarily solved by changing the configuration parameter, even if the original value was correct. Report this problem to your service representative if you use this temporary change.

**Parent topic:** [Symbolic FRUs](#)

---

## UJC35

A configuration parameter may be incorrect.

To determine the configuration parameter that was identified as a possible problem, search for the error in the Service Action Log (see [Using the Service Action Log](#)) and display the failing item information for the error. The failing item description associated with this symbolic FRU identifies the parameter that may be the problem.

The configuration parameter that was identified as a possible problem can be verified by displaying the IDLC line description with the `DSPLINID` command.

The line description was created by the `CRTLINASC` command. You may need to review the `CRTLINASC` command information to determine if the configuration parameter is wrong.

Information about commands related to communications can be found in the following manuals:

- CL Programming, SC41 5721 03
- Communications Configuration, SC41 5401 00

Some software problems can be temporarily solved by changing the configuration parameter, even if the original value was correct. Report this problem to your service representative if you see this temporary change.

**Parent topic:** [Symbolic FRUs](#)

---

## UJC36

A configuration parameter may be incorrect.

To determine the configuration parameter that was identified as a possible problem, search for the error in the Service Action Log (see [Using the Service Action Log](#)) and display the failing item information for the error. The failing item description associated with this symbolic FRU identifies the parameter that may be the problem.

The configuration parameter that was identified as a possible problem can be verified by displaying the asynchronous control unit description with the `DSPCTLD` command.

The control unit description was created by the `CRTCTLASC` command. You may need to review the `CRTCTLASC` command information to determine if the suspected configuration parameter is wrong.

Information about commands related to communications can be found in the following manuals:

- CL Programming, SC41 5721 03
- Communications Configuration, SC41 5401 00

Some software problems can be temporarily solved by changing the configuration parameter, even if the original value was correct. Report this problem to your service representative if you see this temporary change.

**Parent topic:** [Symbolic FRUs](#)

---

## UJE31

There could be a problem with the Token-Ring Network Manager program.

Contact the token-ring administrator responsible for your network.

**Parent topic:** [Symbolic FRUs](#)

---

## UJE32

There could be a problem with the Token-Ring Network Management function.

Contact the token-ring administrator responsible for your network.

**Parent topic:** [Symbolic FRUs](#)

---

## UJE33

The token-ring adapter returned status information because it has received a beacon frame from the token-ring network.

The line is still operational; however, if this problem occurs often, you may want to refer to [Physical site planning](#) for information about the electrical requirements and noise problem considerations.

**Parent topic:** [Symbolic FRUs](#)

---

## UJE34

The error message may have been logged from a temporary error that is not caused by equipment failure.

This type of error message sometimes contains information about system performance. See the original system message for cause and recovery information about the error.

**Parent topic:** [Symbolic FRUs](#)

## UJE35

A configuration parameter may be incorrect.

To determine the configuration parameter that was identified as a possible problem, search for the error in the Service Action Log (see [Using the Service Action Log](#)) and display the failing item information for the error. The failing item description associated with this symbolic FRU identifies the parameter that may be the problem.

The configuration parameter that was identified as a possible problem can be verified by displaying the local area network line description with the `DSPLIND` command.

The line description was created by the `CRTLINTRN`, `CRTLINETH`, or `CRTLINDDI` command. You may need to review the appropriate command information to determine if the configuration parameter is wrong.

Some software problems can be temporarily solved by changing the configuration parameter, even if the original value was correct. Report this problem to your service representative if you use this temporary change.

**Parent topic:** [Symbolic FRUs](#)

---

## UJE36

A configuration parameter may be incorrect.

To determine the configuration parameter that was identified as a possible problem, search for the error in the Service Action Log (see [Using the Service Action Log](#)) and display the failing item information for the error. The failing item description associated with this symbolic FRU identifies the parameter that may be the problem.

The configuration parameter that was identified as a possible problem can be verified by displaying the local area network control unit description with the `DSPCTLD` command.

The controller description was created by the `CRTCTLAPPC`, `CRTCTLHOST`, or `CRTCTLRWS` command. You may need to review the appropriate command information to determine if the configuration parameter is wrong.

Some software problems can be temporarily solved by changing the configuration parameter, even if the original value was correct. Report this problem to your service representative if you use this temporary change.

**Parent topic:** [Symbolic FRUs](#)

---

## UJE37

The problem may be at the remote site.

Perform the following:

1. Ask the remote site operator to verify the following:
  - ◆ The remote equipment is powered on and ready.
  - ◆ The configuration values are correct.
  - ◆ The local area network cables are securely connected and are not damaged.
2. If the problem continues, run all available diagnostic tests on the remote equipment and perform the repair action specified.

**This ends the procedure.**

Parent topic: [Symbolic FRUs](#)

---

## UJE38

Too many jobs are running that use the communications controller.

Before you can run your communications job, you must do one or more of the following:

- End any diagnostic program that may be running, such as the Communications Trace Program.
- Vary off a line that is using the controller.
- Lower the speed of a line that uses the controller.

Perform the following to find which lines are using the controller:

1. Vary off the failing line using the `VRFCFG` command.
2. Vary the line on again, with the reset option of the `VRFCFG` command set to Yes. The names of the lines using the controller will be displayed.

**This ends the procedure.**

Parent topic: [Symbolic FRUs](#)

---

## UJE39

The problem may be at the remote site.

Perform the following:

1. Ask the remote site operator to verify the following:
  - ◆ The remote equipment is powered on and ready.
  - ◆ The configuration values are correct.
2. If the problem continues, run all available diagnostic tests on the remote equipment and perform the repair action specified.

**This ends the procedure.**

Parent topic: [Symbolic FRUs](#)

---

## UJE40

The problem may be at the remote site or on the network media.

Perform the following:

1. Ask the remote site operator to verify the following:
  - ◆ The remote equipment is powered on and ready.
  - ◆ The configuration values are correct.
  - ◆ The local area network cables are securely connected and are not damaged.
2. If the problem continues, run all available diagnostic tests on the remote equipment and perform the repair action specified.

**This ends the procedure.**

**Parent topic:** [Symbolic FRUs](#)

---

## UJJ35

A configuration parameter may be incorrect.

To determine the configuration parameter that was identified as a possible problem, search for the error in the Service Action Log (see [Using the Service Action Log](#)) and display the failing item information for the error. The failing item description associated with this symbolic FRU identifies the parameter that may be the problem.

The configuration parameter that was identified as a possible problem can be verified by displaying the X.25 line description with the `DSPLIND` command.

The line description was created by the `CRTLINX25` command. You may need to review the appropriate command information to determine if the configuration parameter is wrong.

Some software problems can be temporarily solved by changing the configuration parameter, even if the original value was correct. Report this problem to your service representative if you use this temporary change.

**Parent topic:** [Symbolic FRUs](#)

---

## UJJ36

A configuration parameter may be incorrect.

To determine the configuration parameter that was identified as a possible problem, search for the error in the Service Action Log (see [Using the Service Action Log](#)) and display the failing item information for the error. The failing item description associated with this symbolic FRU identifies the parameter that may be the problem.

The configuration parameter that was identified as a possible problem can be verified by displaying the X.25 control unit description with the `DSPCTLD` command.

The controller description was created by the `CRTCTLAPPC`, `CRTCTLFNC`, `CRTCTLHOST`, `CRTCTLRWS`, or `CRTCTLASC` command. You may need to review the appropriate command information to determine if the configuration parameter is wrong.

Some software problems can be temporarily solved by changing the configuration parameter, even if the original value was correct. Report this problem to your service representative if you use this temporary change.

**Parent topic:** [Symbolic FRUs](#)

## UJJ37

The error message may have been logged from a temporary error that is not caused by equipment failure.

This type of error message sometimes contains information about system performance. See the original system message for cause and recovery information about the error.

**Parent topic:** [Symbolic FRUs](#)

---

## UJJ38

A user specified X.25 facility, such as packet size, window size, reverse charging, or closed user group, may not have been correctly assigned.

**Parent topic:** [Symbolic FRUs](#)

---

## UJJ39

Look here for information about UJJ39 symbolic FRU.

**Parent topic:** [Symbolic FRUs](#)

---

## ULNZ3

The problem may be a communications line problem.

When a workstation is attached to the system through modems, it may fail or lose communication with the system for various lengths of time. This is due to a communications line problem. Refer to the modem service information to determine how to test the modems and verify that the communications line between the modems is working correctly.

**Parent topic:** [Symbolic FRUs](#)

---

## ULNZ4

Independent workstation and SDLC support.

The system considers an independent workstation to be an attached remote system when it is attached using PC Support asynchronous communications on an ASCII workstation controller.

Perform the following:

- See the *ASCII Work Station Reference*, SA41-3130-00 information for instructions on how to verify that the remote system (independent workstation) that is attached to the failing port is a supported device.
- See the device hardware maintenance and service information for instructions on how to verify that the device is working correctly.

**Parent topic:** [Symbolic FRUs](#)

---

## UNM31

A configuration parameter may be incorrect.

To determine the configuration parameter that was identified as a possible problem, search for the error in the Service Action Log (see [Using the Service Action Log](#)) and display the failing item information for the error.



The failing item description associated with this symbolic FRU identifies the parameter that may be the problem.

The configuration parameter that was identified as a possible problem can be verified by displaying the ISDN network interface description with the `DSPNWIIISDN` command.

The line description was created by the `CRTNWIIISDN` command. You may need to review the appropriate command information to determine if the configuration parameter is wrong.

Some software problems can be temporarily solved by changing the configuration parameter, even if the original value was correct. Report this problem to your service representative if you use this temporary change.

**Parent topic:** [Symbolic FRUs](#)

---

## UNM32

The licensed internal code of the communications I/O card cannot obtain a necessary resource because of a heavy workload.

This can be caused by too many configured stations, too many users, maximum inbound or outbound data sizes, as well as other considerations.

Try to reduce the total workload on the communications I/O controller card by performing one of the following:

- Change the communications configuration
- Vary off any unused lines
- End any service functions that are not needed

**Parent topic:** [Symbolic FRUs](#)

---

## UNM35

There could be a problem at the remote U interface, between the NT1 node and the Integrated Services Digital Network (ISDN).

This interface is a 2-wire connection between the NT1 node and the ISDN. Contact your ISDN provider and have them verify the proper operation of the interface.

**Parent topic:** [Symbolic FRUs](#)

---

## UNM36

There may be a problem in the Integrated Services Digital Network (ISDN).

Contact your ISDN service provider and report the problem.

**Parent topic:** [Symbolic FRUs](#)

---

## UNM38

The required program temporary fix (PTF) is not installed.

To use the specified network type, you must first install a PTF. If the PTF has not been previously installed, install it and try the operation again.

**Parent topic:** [Symbolic FRUs](#)

---

## UNP20

The internal code of the I/O card that detected the error may be defective.

Perform the following:

1. Replace the suspected card.
2. If the failure occurs again, contact your next level of support and report the problem.

**This ends the procedure.**

Parent topic: [Symbolic FRUs](#)

---

## UNU01

Electrical noise in the local environment can cause performance degradation or loss of an ISDN communications link.

Motors, electrical devices, power cables, communications cables, radio transmitters, and magnetic devices can cause noise or electrical interference.

Perform the following:

1. Inspect ISDN cables or wiring located near a source of possible noise or electrical interference.
2. Inspect ISDN cables for damage, incorrect connections, or loose connections.
3. Consult your local ISDN network provider or service representative for assistance in correcting the problem.

**This ends the procedure.**

Parent topic: [Symbolic FRUs](#)

---

## UNU02

The problem may be at the remote location.

Perform the following:

1. Have the remote site operator verify that the remote equipment is powered on and ready, and that the remote configuration values are correct and compatible with the local configuration.
2. If the problem continues, determine if data is being transferred over the remote ISDN interface. This can be done by either using a communications trace (STRSST), or attaching a protocol analyzer to the line.

- ◆ If a line trace reveals that no data is being transferred, then run hardware and diagnostic tests on the remote equipment.
- ◆ If data is crossing the ISDN interface, analyze the failing protocol procedures to determine which configuration parameters to change. Consult your service representative for help with this analysis.

**This ends the procedure.**

**Parent topic:** [Symbolic FRUs](#)

---

## UNU31

A configuration parameter may be incorrect.

To determine the configuration parameter that was identified as a possible problem, search for the error in the Service Action Log (see [Using the Service Action Log](#)) and display the failing item information for the error. The failing item description associated with this symbolic FRU identifies the parameter that may be the problem.

The configuration parameter that was identified as a possible problem can be verified by displaying the IDLC line description with the `DSPLINIDLC` command.

The line description was created by the `CRTLINIDLC` command. You may need to review the appropriate command information to determine if the configuration parameter is wrong.

Some software problems can be temporarily solved by changing the configuration parameter, even if the original value was correct. Report this problem to your service representative if you use this temporary change.

**Parent topic:** [Symbolic FRUs](#)

---

## UNU32

A configuration parameter may be incorrect.

To determine the configuration parameter that was identified as a possible problem, search for the error in the Service Action Log (see [Using the Service Action Log](#)) and display the failing item information for the error. The failing item description associated with this symbolic FRU identifies the parameter that may be the problem.

The configuration parameter that was identified as a possible problem can be verified by displaying the IDLC controller description with the `DSPCTLD` command.

The controller description was created by the `CRTCTLHOST`, `CRTCTLAPPC`, or `CRTCTLRWS` command. You may need to review the appropriate command information to determine if the configuration parameter is wrong.

Some software problems can be temporarily solved by changing the configuration parameter, even if the original value was correct. Report this problem to your service representative if you use this temporary change.

**Parent topic:** [Symbolic FRUs](#)

---

## UPLF1

The system may not have been able to complete the APPN session initiation due to the number of jobs that were active when the timeout occurred.

The timeout condition could have been caused by a system performance problem. System performance could be impacted by the capacity of the system. System performance can also be impacted by processing requests from other systems in the network.

Parent topic: [Symbolic FRUs](#)

---

## UPSUNIT

The uninterruptible power supply (UPS) may be the failing component.

Perform the following:

1. Is the problem that the system has a UPS reference code, but the UPS does not have a fault code?
  - ◆ **Yes:** Continue with the next step.
  - ◆ **No:** Go to step 3.
2. Remove the UPS signal cable from the system connector. Does the system report a UPS reference code now?
  - ◆ **No:** Continue with the next step.
  - ◆ **Yes:** Replace the following, one at a time, until the problem is resolved:
    - a. Tower card (see [TWRCARD](#))
    - b. Remote power controller (RPC)

**This ends the procedure.**
3. Perform the following:
  - a. Verify the UPS signal cable, between the UPS and the system, is connected and seated properly.
  - b. Have the customer call the UPS provider for service if a problem is found.
  - c. Call service support if the problem prevails after the UPS is verified as working correctly.

**This ends the procedure.**

Parent topic: [Symbolic FRUs](#)

---

## USER

There has been a system operator error or user error. See the system operator information.

Parent topic: [Symbolic FRUs](#)

---

## UX201

The printer definition table may be causing the problem. See the original system message for cause and recovery information about the error.

Parent topic: [Symbolic FRUs](#)

---

## UX202

A problem was detected while downloading a device licensed internal code change to the device.

See the original system message for cause and recovery information about the error.

Parent topic: [Symbolic FRUs](#)

## UY1Z1

Indicates possible cable problems

Problems that are associated with noise can cause a workstation to fail or lose communication with the system for various lengths of time. A motor or any device that is a source of electrical radiation can cause noise or electrical interference. The following are common causes for noise problems:

- Cables that are located near a source of electrical interference.
- Cables that are loose, damaged, or not correctly connected

**Parent topic:** [Symbolic FRUs](#)

---

## UY1Z2

This error occurs if you attempted to activate more workstations than the amount allowed.

Perform one of the following to correct the problem:

- Turn off the power for the workstation that caused the error, or connect the workstation to a different controller.
- Turn off the power for a different workstation that is connected to the same workstation controller.

See the local workstation diagrams for the physical location of workstations.

**This ends the procedure.**

**Parent topic:** [Symbolic FRUs](#)

---

## UY1Z3

This error is caused by a workstation that is connected to the port.

1. Perform the following:
  - a. Turn off the power for one workstation on the port
  - b. Check if the other workstations operate correctly.
  - c. Repeat this for each workstation on the port.
  - d. The workstation that causes the problem is the one that is turned off when the others are working correctly.
  - e. If you did not find the problem, continue with the next step.
2. Perform the following:
  - a. Turn off the power for all workstations on the port.
  - b. Then, turn on one workstation to check if it works when all other workstations are turned off.
  - c. Repeat this for each workstation on the port. The workstation that causes the problem is the one that works when all other workstations are turned off.

This ends the procedure.

**Parent topic:** [Symbolic FRUs](#)

---

## UY1Z4

An error occurred with the pass-through command between the workstation controller and the workstation.

A failure in the licensed internal code (LIC) in either the workstation or the workstation controller causes this type of error.

Parent topic: [Symbolic FRUs](#)

---

## UY1Z5

The communication between the workstation controller and a workstation was interrupted during an active session.

Possible causes include:

- The power for the workstation was turned off, then on.
- A temporary loss of power to the workstation occurred.

Parent topic: [Symbolic FRUs](#)

---

## VPDPART

Look here for information about VPDPART symbolic FRU.

1. Is the reference code 1xxx 8402?
  - ◆ **No:** Continue with the next step.
  - ◆ **Yes:** Prior to exchanging any parts, verify that the processors are installed. If you are in test mode and have removed all of the processors, disregard this reference code. Otherwise, correct the processors. If the processors are installed correctly, then exchange the service processor card (see [SVCPROC](#)). **This ends the procedure.**
2. Is the reference code 1xxx 8404, 8405, or 8406?
  - ◆ **No:** Continue with the next step.
  - ◆ **Yes:** Use the following table to find the correct action to take. See [Finding part locations](#) for part number and exchange information.

| Reference code | Action                                                                  |
|----------------|-------------------------------------------------------------------------|
| 1xxx 8404      | Processor card mismatch. Exchange processor card 2 in the primary unit. |
| 1xxx 8405      | Processor card mismatch. Exchange processor card 1 in a secondary unit. |
| 1xxx 8406      | Processor card mismatch. Exchange processor card 2 in a secondary unit. |

**This ends the procedure.**

3. Is the reference code 1xxx 8409?
  - ◆ **No:** Continue with the next step.
  - ◆ **Yes:** No processors are installed. If you are in test mode and have removed all of the processors, disregard this reference code. Otherwise, correct the processors. If the processors are installed correctly, exchange all processors. See [Finding part locations](#) for part number and exchange information. **This ends the procedure.**
4. Is the reference code 1xxx 8413 or 8414?
  - ◆ **No:** Continue with the next step.
  - ◆ **Yes:** Perform the following:

**Note:** See [Finding part locations](#) for part and location information.

◇ For a model 112/85, ESCALA PL 250R-VL or ESCALA PL 450R-XS, ESCALA PL 250R-L, PL 250R-L+ or PL 450R-VL+, ESCALA PL 250T/R, PL 250T/R+ or PL

- 450T/R-L+, , replace the system unit backplane (see [SYSBKPL](#)).
- ◇ For a model ESCALA PL 450T/R, PL 450T/R+ or PL 850T/R-L+, ESCALA PL 1650R-L+, ESCALA PL 850R/PL 1650R/R+ , , use the reference code in the following table to find the FRU.

| Reference code | Action                |
|----------------|-----------------------|
| 1xxx 8413      | Exchange processor 1. |
| 1xxx 8414      | Exchange processor 2. |

**This ends the procedure.**

5. Are you working on a model 5/75, ESCALA PL 3250R, PL 3250R+, ESCALA PL 6450 or PL 6450R+?
- ◆ **No:** Continue with the next step.
  - ◆ **Yes:** Go to step 7.
6. Is the reference code 1xxx 8423 or 8424?
- ◆ **No:** Go to step 8.
  - ◆ **Yes:** Perform the following:

**Note:** See [Finding part locations](#) for part and location information.

- ◇ For a model 112/85, ESCALA PL 250R-VL or ESCALA PL 450R-XS, ESCALA PL 250R-L, PL 250R-L+ or PL 450R-VL+, ESCALA PL 250T/R, PL 250T/R+ or PL 450T/R-L+, , replace the system unit backplane (see [SYSBKPL](#)).
- ◇ For a model ESCALA PL 450T/R, PL 450T/R+ or PL 850T/R-L+, ESCALA PL 1650R-L+, ESCALA PL 850R/PL 1650R/R+, , use the reference code in the following table to find the FRU.

| Reference code | Action                |
|----------------|-----------------------|
| 1xxx 8423      | Exchange processor 1. |
| 1xxx 8424      | Exchange processor 2. |

If this replacement does not fix the problem, replace the system I/O backplane (see [SYSBKPL](#)). **This ends the procedure.**

7. Is the 1xxx reference code in one of the following ranges?
- ◆ 8410 through 8417
  - ◆ 8420 through 8427
  - ◆ 8470 through 8477
  - ◆ **No:** Go to step 8.
  - ◆ **Yes:** Use the following table to replace the appropriate FRU. **This ends the procedure.**

| SRC              | System model                                            | FRU to replace      | Link to locations                                                                   |
|------------------|---------------------------------------------------------|---------------------|-------------------------------------------------------------------------------------|
| 8410, 8420, 8470 | 5/75                                                    | Processor backplane | <a href="#">Locations</a> <a href="#">model 5/75</a>                                |
|                  | ESCALA PL 3250R, PL 3250R+, ESCALA PL 6450 or PL 6450R+ | MCM 0 on node 0     | <a href="#">Locations</a> <a href="#">model ESCALA PL 3250R and ESCALA PL 6450R</a> |
| 8411, 8421, 8471 | ESCALA PL 3250R, PL 3250R+, ESCALA PL 6450 or PL 6450R+ | MCM 1 on node 0     | <a href="#">Locations</a> <a href="#">model ESCALA PL 3250R and ESCALA PL 6450R</a> |
| 8412, 8422, 8472 |                                                         | MCM 0 on node 1     |                                                                                     |
| 8413, 8423, 8473 |                                                         | MCM 1 on node 1     |                                                                                     |
| 8414, 8424, 8474 |                                                         | MCM 0 on node 2     |                                                                                     |
| 8415, 8425, 8475 |                                                         | MCM 1 on node 2     |                                                                                     |

|                  |                 |
|------------------|-----------------|
| 8416, 8426, 8476 | MCM 0 on node 3 |
| 8417, 8427, 8477 | MCM 1 on node 3 |

8. Is the reference code 1xxx 911C?

- ◆ **Yes:** Two nodes have the same VPD. **This ends the procedure.**
- ◆ **No:** Return to [Start of call procedure](#). **This ends the procedure.**

Parent topic: [Symbolic FRUs](#)

---

## VRMOD

The system detected a voltage problem.

Perform the following to service this FRU.

1. Power off the system.
2. Unplug the AC.
3. Reseat the VRMs. (For more information, see [Finding part locations](#).) Does that resolve the problem?
  - ◆ **Yes: This ends the procedure.**
  - ◆ **No:** Continue with the next step.
4. Replace the VRMs. (For more information, see [Removing and replacing parts](#).)

**This ends the procedure.**

Parent topic: [Symbolic FRUs](#)

---

## Failing Function Codes (FFCs)

Failing function codes represent functions within the system unit.

**Note:** When replacing a FRU, use [MAP 0410: Repair checkout](#) to verify the fix.

The failing function codes are listed in numerical sequence.

A function may not be physically packaged on the same FRU in various system units. When this condition exists, the FRU part number for each type of system unit is listed.

### Column Heading Term Definitions

The columns in the failing function code list are as follows:

- **Failing function code** The failing function code number from the SRN list in [MAP 0260: System hangs during resource configuration](#).
- **Machine type/model** This column is used when the failing function is on a FRU which differs by machine type and model. Use the part number for the type of system unit you are servicing.



**Note:** Although the machine cover logo may depict the model number as four digits, the service and parts ordering system requires three-digit numbers. For example, if the cover logo depicts model number xxxx, service and parts documentation may refer to that model as xxx.

- **Part number** This column contains the part number of the FRU that contains the failing function. Use the part number for the type of system unit you are servicing.
- **Description and notes** This column contains the description of the FRU and any usage notes. The FRU description may be different in different system units. Use the one for the type of system unit you are servicing.

Select [System parts](#) to access the failing function code listing.

## MAP 0260: System hangs during resource configuration

Use this MAP when the system unit hangs while configuring a resource.

### Purpose of this MAP

This MAP handles problems when the system unit hangs while configuring a resource.

- Step 0260-1

The last three or four digits of the SRN following the dash (-) match a failing function code number.

Look at the [System parts](#) and find the failing function code that matches the last three or four digits of your SRN, following the dash. Record the FRU part number and description (use the first FRU part listed when multiple FRUs are listed).

The physical location code, AIX location code, or device name is displayed on the operator panel.

#### Do you have either a physical location code or AIX location code displayed?

No

Go to [Step 0260-4](#).

Yes

Go to [Step 0260-2](#).

- Step 0260-2

#### Are there any FRUs attached to the device described by the physical location code or AIX location code?

No

Go to [Step 0260-6](#).

Yes

Go to [Step 0260-3](#).

- Step 0260-3

Remove this kind of FRU attached to the device described in the location code one at a time. Note whether the system still hangs after each device is removed. Do this until you no longer get a hang, or all attached FRUS have been removed from the adapter or device.

#### Has the symptom changed?

No

Go to [Step 0260-4](#).

Yes

Use the location code of the attached device that you removed when the symptom changed, and go to [Step 0260-6](#).

- Step 0260-4

**Does your system unit contain only one of this kind of FRU?**

No

Go to [Step 0260-5](#).

Yes

Go to [Step 0260-6](#).

- Step 0260-5

One of the FRUs of this kind is defective.

Remove this kind of FRU one at a time. Test the system unit after each FRU is removed. Stop when the test completes successfully or when you have removed all of the FRUs of this kind.

**Were you able to identify a failing FRU?**

No

Go to [MAP 1540: Problem Isolation Procedure](#).

Yes

Go to [Step 0260-6](#).

- Step 0260-6

1. Turn off the system unit.

2. Exchange the FRU identified by the location code or [Step 0260-5](#).

**Is this system capable of running online diagnostics in service mode?**

No

Go to [Step 02607](#).

Yes

Go to [Step 02608](#).

- Step 0260-7

1. Turn on the system unit.

2. Load the standalone diagnostics and refer to [Loading and using the AIX online diagnostics or the standalone diagnostics](#).

3. Wait until the Diagnostic Operating Instructions display or the system appears to have stopped.

**Are the DIAGNOSTIC OPERATING INSTRUCTIONS displayed?**

NO

Go to [Step 02609](#).

YES

Go to [MAP 0410: Repair Checkout](#).

- Step 0260-8

1. Turn on the system unit.

2. Load the standalone diagnostics and refer to [Loading and using the AIX online diagnostics or the standalone diagnostics](#).

3. Wait until the Diagnostic Operating Instructions display or the system appears to have stopped.

**Are the DIAGNOSTIC OPERATING INSTRUCTIONS displayed?**

NO

Go to [Step 0260-9](#).

YES

Go to [MAP 0410: Repair Checkout](#).

- Step 0260-9

Look at the operator panel display.

**Is the number displayed the same as the last three or four digits after the dash (-) of your SRN?**

NO

The symptom changed. Check for loose cards, cables, and obvious problems. If you do not find a problem, go to [MAP 0020: Problem Determination Procedure](#) and get a new SRN.

YES

Go to [Step 0260-10](#).

- Step 0260-10

**Was the FRU you exchanged an adapter or a planar?**

NO

Go to [Step 0260-11](#).

YES

Go to [MAP 1540: Problem Isolation Procedure](#).

- Step 0260-11

**Was the FRU you exchanged a device?**

NO

Go to [MAP 1540: Problem Isolation Procedure](#).

YES

Go to [Step 0260-12](#).

- Step 0260-12

The adapter for the device may be causing the problem.

1. Turn off the system unit.
2. Exchange the adapter for the device.

**Note:** If the AIX operating system is not used on the system, start diagnostics from an alternate source.

3. Turn on the system unit. If `c31` is displayed, follow the instructions to select a console display.
4. Load the standalone diagnostics and refer to [Loading and using the AIX online diagnostics or the standalone diagnostics](#).
5. Wait until the DIAGNOSTIC OPERATING INSTRUCTIONS display or the system appears to have stopped.

**Are the DIAGNOSTIC OPERATING INSTRUCTIONS displayed?**

NO

Go to [MAP 1540: Problem Isolation Procedure](#).

YES

Go to [MAP 0410: Repair Checkout](#).

## System parts

Use this information to find part numbers for parts that have CCIN or Failing Function Code numbers.

The following tables map a CCIN, hardware type, or Failing Function Code to a part number. See the following for other parts:

- For mechanical and connecting parts, see [Part assembly diagrams](#).
- For internal signal and power cables and external cables, see [Cables](#).
- For miscellaneous parts such as cable wraps or cleaning kits, see [Miscellaneous parts](#).
- For Hardware Management Console (HMC) parts, see [Hardware Management Console \(HMC\) parts](#).

Choose the part you want to replace:

- [Backplane parts](#)
- [Processor parts](#)
- [Bus parts](#)
- [Cables](#)
- [Control panel parts](#)
- [Disk unit parts](#)
- [Keyboard parts](#)
- [Memory parts](#)
- [Miscellaneous](#)
- [Non-storage IOA and IOP parts](#)

- Power parts
- Removable media device parts
- Storage parts
- VPD parts
- OpenPower parts by failing function code

## Backplane parts

| CCIN                                                                                  | Failing Function Code | Description                                                                  | Model, expansion unit, or unit type     | Part number |
|---------------------------------------------------------------------------------------|-----------------------|------------------------------------------------------------------------------|-----------------------------------------|-------------|
| <b>Model ESCALA PL 245T/R backplanes:</b>                                             |                       |                                                                              |                                         |             |
| 5324                                                                                  | 282, 2C4, 308         | System backplane, 1 way, 2.5 GHz<br>FFC 308 is an I/O bridge problem.        | 471/85, ESCALA PL 245T/R                | 42R5210     |
| 5325                                                                                  | 282, 2C4, 308         | System backplane, 2 way, 2.5 GHz<br>FFC 308 is an I/O bridge problem.        | 471/85, ESCALA PL 245T/R                | 42R5211     |
| <b>Model ESCALA PL 250R-VL or ESCALA PL 450R-XS backplanes:</b>                       |                       |                                                                              |                                         |             |
|                                                                                       |                       | Ultra320 SCSI RAID, SFF daughter card                                        | ESCALA PL 250R-VL or ESCALA PL 450R-XS  | 39J5676     |
|                                                                                       | 282, 2C4, 308, 254A   | System backplane, 1 way, 1.65 GHz<br>FFC 308 is an I/O bridge problem.       | ESCALA PL 250R-VL or ESCALA PL 450R-XS  | 03N7073     |
|                                                                                       | 282, 2C4, 308, 254C   | System backplane, 2 way, 1.65 GHz<br>FFC 308 is an I/O bridge problem.       | ESCALA PL 250R-VL or ESCALA PL 450R-XS  | 03N7082     |
|                                                                                       | 282, 2C4, 308, 254D   | System backplane, 2 way, 1.5 GHz<br>FFC 308 is an I/O bridge problem.        | ESCALA PL 250R-VL or ESCALA PL 450R-XS  | 03N7090     |
| <b>Model ESCALA PL 250R-L and ESCALA PL 250R-L+ or ESCALA PL 450R-VL+ backplanes:</b> |                       |                                                                              |                                         |             |
|                                                                                       |                       | Ultra320 SCSI RAID, SFF daughter card                                        | ESCALA PL 250R-L+ or ESCALA PL 450R-VL+ | 39J5676     |
| 261D                                                                                  | 282, 2C4, 308         | System backplane, 1 way, 1.5 GHz, no L3<br>FFC 308 is an I/O bridge problem. | ESCALA PL 250R-L                        | 03N6254     |
| 261E                                                                                  | 282, 2C4, 308         | System backplane, 1 way, 1.65 GHz                                            | ESCALA PL 250R-L                        | 03N6242     |

## Service provider information

|                                                                                      |               |                                                                               |                                          |         |
|--------------------------------------------------------------------------------------|---------------|-------------------------------------------------------------------------------|------------------------------------------|---------|
|                                                                                      |               | FFC 308 is an I/O bridge problem.                                             |                                          |         |
| 261F                                                                                 | 282, 2C4, 308 | System backplane, 2 way, 1.65 GHz<br>FFC 308 is an I/O bridge problem.        | ESCALA PL 250R-L                         | 03N6217 |
| 262A                                                                                 | 282, 2C4, 308 | System backplane, 2 way, 1.5 GHz<br>FFC 308 is an I/O bridge problem.         | ESCALA PL 250R-L                         | 03N6268 |
|                                                                                      | 282, 2C4, 308 | System backplane, 1 way, 1.9 GHz<br>FFC 308 is an I/O bridge problem.         | ESCALA PL 250R-L+ or ESCALA PL 450R-VL+  | 03N7217 |
|                                                                                      | 282, 2C4, 308 | System backplane, 0-2 way, 1.9 GHz<br>FFC 308 is an I/O bridge problem.       | ESCALA PL 250R-L+ or ESCALA PL 450R-VL+  | 03N7207 |
|                                                                                      | 282, 2C4, 308 | System backplane, 4 way, 1.5 GHz<br>FFC 308 is an I/O bridge problem.         | ESCALA PL 250R-L+ or ESCALA PL 450R-VL+  | 03N7197 |
| 52B0                                                                                 | 308           | PCI-adapter riser enclosure, double high<br>FFC 308 is an I/O bridge problem. | ESCALA PL 250R-L+ or ESCALA PL 450R-VL+  | 03N7051 |
| 52B1                                                                                 | 308           | PCI-adapter riser enclosure, single high<br>FFC 308 is an I/O bridge problem. | ESCALA PL 250R-L+ or ESCALA PL 450R-VL+  | 03N7054 |
| 6B15                                                                                 | 308           | PCI adapter and riser enclosure<br>FFC 308 is an I/O bridge problem.          | ESCALA PL 250R-L, 7/10                   | 03N5849 |
|                                                                                      |               | <a href="#">Disk unit backplanes</a> , listed below                           |                                          |         |
|                                                                                      |               | <a href="#">Media backplanes</a> , listed below                               |                                          |         |
| <b>Model ESCALA PL 250T/R, ESCALA PL 250T/R+ or ESCALA PL 450T/R-L+, backplanes:</b> |               |                                                                               |                                          |         |
| 28D2                                                                                 |               |                                                                               | , , , ,                                  | 03N6000 |
| 5228                                                                                 | 282, 2C4, 308 | System backplane, 1 way, 1.65 GHz DCM processor                               | 9405-520, 9406-520                       | 03N6629 |
| 5229                                                                                 | 282, 2C4, 308 | System backplane, 2 way, 1.65 GHz DCM processor                               | ESCALA PL 250T/R, 9405-520, 9406-520     | 03N6221 |
| 522A                                                                                 | 282, 2C4, 308 | System backplane, 1 way, 1.5 GHz SCM processor                                | ESCALA PL 250T/R, 9405-520, 9406-520     | 03N6612 |
| 523C                                                                                 | 282, 2C4, 308 | System backplane, 2 way, 1.5 GHz DCM processor                                | ESCALA PL 250T/R                         | 03N6638 |
| 8321                                                                                 | 282, 2C4, 308 | System backplane, 1 way, 1.65 GHz D, DDR2, GS2, SCM                           | ESCALA PL 250T/R+ or ESCALA PL 450T/R-L+ | 39J4072 |
| 8323                                                                                 |               |                                                                               |                                          | 39J4067 |

Service provider information

|                                                                                           |                    |                                                                                                                                                 |                                                          |         |
|-------------------------------------------------------------------------------------------|--------------------|-------------------------------------------------------------------------------------------------------------------------------------------------|----------------------------------------------------------|---------|
|                                                                                           | 282, 2C4, 308      | System backplane, 0-2 way<br>1.65 GHz, DDR2, GS2, DCM                                                                                           | ESCALA PL 250T/R+ or ESCALA PL 450T/R-L+                 |         |
| 8325                                                                                      | 282, 2C4, 308      | System backplane, 1 way,<br>1.9 GHz, DDR2, GS2, SCM                                                                                             | ESCALA PL 250T/R, 9405-520, 9406-520                     | 39J4251 |
| 8327                                                                                      | 282, 2C4, 308      | System backplane, 1 way,<br>1.9 GHz, DDR2, GS2, DCM                                                                                             | , ,                                                      | 39J4531 |
| 8330                                                                                      | 282, 2C4, 308      | System backplane, 0-2 way,<br>1.9 GHz, DDR2, GS2, DCM                                                                                           | , ,                                                      | 39J4045 |
| 8333                                                                                      | 282, 2C4, 308      | System backplane, 0-4 way,<br>1.5 GHz, DDR, GS23, QCM                                                                                           | ESCALA PL 250T/R+ or ESCALA PL 450T/R-L+                 | 39J4078 |
|                                                                                           |                    | <a href="#">Disk unit backplanes</a> , listed below                                                                                             |                                                          |         |
|                                                                                           |                    | <a href="#">Media backplanes</a> , listed below                                                                                                 |                                                          |         |
| <b>Model ESCALA PL 450T/R, ESCALA PL 450T/R+ or ESCALA PL 850T/R-L+, 7/20 backplanes:</b> |                    |                                                                                                                                                 |                                                          |         |
| 28A2                                                                                      | 282, 2C4, 308      | System backplane, includes FSP<br><br>This backplane receives pluggable system processor assemblies, see <a href="#">Processor parts</a> below. | 9406-550                                                 | 03N7301 |
| 28D9                                                                                      | 282, 2C4, 308      | System backplane<br><br>This backplane receives pluggable system processor assemblies, see <a href="#">Processor parts</a> below.               | ESCALA PL 450T/R+ or ESCALA PL 850T/R-L+                 | 10N6472 |
| 28EC                                                                                      | 282, 2C4, 308      | System backplane<br><br>This backplane receives pluggable system processor assemblies, see <a href="#">Processor parts</a> below.               | ESCALA PL 450T/R, 9406-550, 7/20                         | 03N7294 |
| 5237                                                                                      |                    | System backplane, 0-2 way<br>1.65 GHz, 36 MB internal cache and 8 memory DIMM slots.                                                            | , ,                                                      | 03N7294 |
|                                                                                           |                    | <a href="#">Disk unit backplanes</a> , listed below                                                                                             |                                                          |         |
|                                                                                           |                    | <a href="#">Media backplanes</a> , listed below                                                                                                 |                                                          |         |
| <b>Model ESCALA PL 1650R-L+ and ESCALA PL 850R/PL 1650R/R+ backplanes:</b>                |                    |                                                                                                                                                 |                                                          |         |
| 25F8                                                                                      |                    | Passthru card                                                                                                                                   | , ,                                                      | 39J0780 |
| 27AE                                                                                      | 282, 2C4, 308      | System backplane<br><br>This backplane receives pluggable system processor assemblies, see <a href="#">Processor parts</a> below.               | ESCALA PL 1650R-L+, ESCALA PL 850R/PL 1650R/R+, 9406-570 | 10N7272 |
| 28DA                                                                                      | 221, 227, 2C8, 292 | I/O backplane                                                                                                                                   | ESCALA PL 1650R-L+, ESCALA PL 850R/PL 1650R/R+, 9406-570 | 42R5104 |
| 7733                                                                                      |                    | I/O backplane                                                                                                                                   |                                                          | 42R5113 |
|                                                                                           | 221, 227, 2C8, 292 | I/O backplane                                                                                                                                   | ESCALA PL 1650R-L+                                       | 42R5104 |
|                                                                                           |                    | <a href="#">Disk unit backplanes</a> , listed below                                                                                             |                                                          |         |
|                                                                                           |                    | <a href="#">Media backplanes</a> , listed                                                                                                       |                                                          |         |

|                                                              |                    |                                                                                                                                    |                                            |         |
|--------------------------------------------------------------|--------------------|------------------------------------------------------------------------------------------------------------------------------------|--------------------------------------------|---------|
|                                                              |                    | below                                                                                                                              |                                            |         |
| <b>Model 5/75 backplanes:</b>                                |                    |                                                                                                                                    |                                            |         |
| 260D                                                         | 282, 2C4, 308      | System processor backplane, 1.9 GHz                                                                                                | 185/75                                     | 03N7251 |
| 28F0                                                         | 221, 227, 28C, 292 | I/O backplane assembly                                                                                                             | 185/75                                     | 03N6819 |
| 7657                                                         | 282, 2C4, 308      | 16 way 1.5 GHz DCM processor (GR) L3, system planar (0-16 way includes 16 activations)<br><br>FFC 308 is an I/O bridge problem.    | 185/75                                     | 03N7119 |
| <b>Model ESCALA PL 3250R and ESCALA PL 6450R backplanes:</b> |                    |                                                                                                                                    |                                            |         |
| 28E0                                                         | 282, 2C4, 308      | Processor book (also referred to as a node backplane). The lift tool (09P2481) is required for installation.                       | 9406-595, ESCALA PL 3250R, ESCALA PL 6450R | 12R6528 |
| 28E1                                                         | 282, 2C4, 308      | Processor book (also referred to as a node backplane). The lift tool (09P2481) is required for installation.                       | 9406-595, ESCALA PL 3250R, ESCALA PL 6450R | 12R8747 |
|                                                              | 282, 2C4, 308      | Processor book, 16 way, Power BackUP (also referred to as a node backplane). The lift tool (09P2481) is required for installation. | ESCALA PL 6450R                            | 60H2319 |
|                                                              |                    | <a href="#">Disk unit backplanes</a> , listed below                                                                                |                                            |         |
|                                                              |                    | <a href="#">Media backplanes</a> , listed below                                                                                    |                                            |         |
| <b>Model 7/10 backplanes:</b>                                |                    |                                                                                                                                    |                                            |         |
| 261B                                                         | 282, 2C4, 308      | System backplane, 1 way, 1.65 GHz                                                                                                  | 7/10                                       | 03N6228 |
| 261C                                                         | 282, 2C4, 308      | System backplane, 2 way 1.65 GHz                                                                                                   | 7/10                                       | 03N6204 |
|                                                              |                    | <a href="#">Disk unit backplanes</a> , listed below                                                                                |                                            |         |
|                                                              |                    | <a href="#">Media backplanes</a> , listed below                                                                                    |                                            |         |
| <b>Model , 11D/11, and 57/90 backplanes:</b>                 |                    |                                                                                                                                    |                                            |         |
|                                                              | 221, 227, 28C, 292 | I/O drawer backplane                                                                                                               |                                            | 09P5921 |
| 282A                                                         | 221, 227, 28C, 292 | I/O drawer backplane                                                                                                               | 57/90, 11D/11                              | 23R0181 |
| 28BB                                                         | 221, 227, 28C, 292 | I/O drawer backplane (initial shipments only)                                                                                      | 11D/11                                     | 23R0181 |
|                                                              | 221, 227, 28C, 292 | I/O drawer backplane                                                                                                               | , 11D/11                                   | 09P5912 |
| <b>Model 11D/20 backplanes:</b>                              |                    |                                                                                                                                    |                                            |         |
|                                                              | 221, 227, 28C, 292 | I/O drawer backplane                                                                                                               | 11D/20                                     | 39J0515 |
|                                                              |                    | <a href="#">Disk unit backplanes</a> , listed below                                                                                |                                            |         |
|                                                              |                    | <a href="#">Media backplanes</a> , listed below                                                                                    |                                            |         |
| <b>Model D24, T24, 57/86, and 57/87 backplanes:</b>          |                    |                                                                                                                                    |                                            |         |

## Service provider information

|                                                                                              |     |                                                                                                                                                          |                                                                                |         |
|----------------------------------------------------------------------------------------------|-----|----------------------------------------------------------------------------------------------------------------------------------------------------------|--------------------------------------------------------------------------------|---------|
| 506D                                                                                         |     | SCSI repeater card assembly, dual                                                                                                                        | 57/86, 57/87, D24, T24                                                         | 12R9040 |
| 506E                                                                                         |     | SCSI repeater card assembly, single                                                                                                                      | 57/86, 57/87, D24, T24                                                         | 12R9042 |
|                                                                                              |     | The disk drive backplane is part of the chassis assembly FRU, see <a href="#">Part assembly diagrams for 57/86, 57/87, D24, and T24 expansion units.</a> |                                                                                |         |
| <b>Model 50/74, 50/79, 8093-002 backplanes:</b>                                              |     |                                                                                                                                                          |                                                                                |         |
| 283C                                                                                         |     | Device backplane (DB3)                                                                                                                                   | 50/74, 50/79, 8093-002                                                         | 42R3859 |
| 283D                                                                                         |     | Device backplane (DB1 and DB2)                                                                                                                           | 50/74, 50/79, 8093-002                                                         | 39J2931 |
| <b>Model 50/74, 50/79, 8079-002 backplanes:</b>                                              |     |                                                                                                                                                          |                                                                                |         |
|                                                                                              |     | I/O tower backplane with stiffener                                                                                                                       | 50/74, 50/79                                                                   | 39J2931 |
| 28AB                                                                                         |     | I/O backplane                                                                                                                                            | 50/74, 50/79, 8079-002                                                         | 97H7307 |
| <b>Model 50/94, 52/94, 8094-002, 82/94 backplanes:</b>                                       |     |                                                                                                                                                          |                                                                                |         |
| 28B7                                                                                         |     | I/O backplane                                                                                                                                            | 50/94, 52/94, 8094-002, 82/94                                                  | 39J3058 |
| <b>Model 50/88, 05/88 backplanes:</b>                                                        |     |                                                                                                                                                          |                                                                                |         |
| 28B8                                                                                         |     | I/O backplane                                                                                                                                            | 50/88, 05/88                                                                   | 53P6026 |
| <b>Model 50/95 and 05/95 backplanes:</b>                                                     |     |                                                                                                                                                          |                                                                                |         |
| 28B9                                                                                         |     | Device backplane assembly (DB1 and DB2) (concurrent maintenance)                                                                                         | 50/95, 05/95                                                                   | 39J1695 |
| 28BE                                                                                         |     | I/O backplane                                                                                                                                            | 50/95                                                                          | 39J0515 |
|                                                                                              |     | <a href="#">Disk unit backplanes</a> , listed below                                                                                                      |                                                                                |         |
| <b>Model 57/91, 57/94 backplanes:</b>                                                        |     |                                                                                                                                                          |                                                                                |         |
| 28C6                                                                                         |     | I/O backplane                                                                                                                                            | 57/91, 57/94                                                                   | 41V1231 |
| <b>Model 50/94, 52/94, 8093-001, 82/94 backplanes:</b>                                       |     |                                                                                                                                                          |                                                                                |         |
| 28CB                                                                                         |     | Device backplane (DB3)                                                                                                                                   | 50/94, 52/94, 8093-001, 82/94                                                  | 42R3859 |
| 28CC                                                                                         |     | Device backplane (DB1 and DB2)                                                                                                                           | 50/94, 52/94, 8093-001, 82/94                                                  | 39J2931 |
| <b>Disk unit backplanes</b> sometimes referred to as SCSI Enclosure Service (SES) backplane: |     |                                                                                                                                                          |                                                                                |         |
| 28DB                                                                                         | 199 | Disk unit backplane                                                                                                                                      | ESCALA PL 1650R-L+, ESCALA PL 850R/PL 1650R/R+, 9406-570                       | 03N4801 |
| 28DF                                                                                         | 199 | Disk unit backplane (an Ultra320 SCSI PCI adapter card is required to connect this backplane)                                                            | 9405-520, 9406-520                                                             | 80P3561 |
| 28F6                                                                                         | 199 | Ultra320 SCSI 4-Pack backplane                                                                                                                           | ESCALA PL 450T/R, ESCALA PL 450T/R+ or ESCALA PL 850T/R-L+, 9406-550, 7/20     | 03N5998 |
| 28F7                                                                                         | 199 | Disk drive backplane, 4-slot expansion                                                                                                                   | ESCALA PL 450T/R, ESCALA PL 450T/R+ or ESCALA PL 850T/R-L+, 9406-550, 7/20     | 03N5880 |
| 292C                                                                                         |     | Disk drive backplane for external SCSI port. (This feature enables external SCSI devices to connect to internal SCSI controller ports)                   | ESCALA PL 450T/R, ESCALA PL 450T/R+ or ESCALA PL 850T/R-L+, 9406-550, 7/20     | 03N5876 |
| 292D                                                                                         | 199 | Disk unit backplane (an Ultra320 SCSI PCI adapter card is required to connect                                                                            | ESCALA PL 250T/R, ESCALA PL 250T/R+ or ESCALA PL 450T/R-L+, 9405-520, 9406-520 | 03N5878 |



|                                                                                                                                              |     |                                                                                                                                                                                                                                                                            |                                                                                                                                                                                                                                                                                                                                                                                                                                                                                                                                                                                                                                                                                                                                                                                                                                                                                                                                                                                                 |         |
|----------------------------------------------------------------------------------------------------------------------------------------------|-----|----------------------------------------------------------------------------------------------------------------------------------------------------------------------------------------------------------------------------------------------------------------------------|-------------------------------------------------------------------------------------------------------------------------------------------------------------------------------------------------------------------------------------------------------------------------------------------------------------------------------------------------------------------------------------------------------------------------------------------------------------------------------------------------------------------------------------------------------------------------------------------------------------------------------------------------------------------------------------------------------------------------------------------------------------------------------------------------------------------------------------------------------------------------------------------------------------------------------------------------------------------------------------------------|---------|
|                                                                                                                                              |     | this backplane)                                                                                                                                                                                                                                                            |                                                                                                                                                                                                                                                                                                                                                                                                                                                                                                                                                                                                                                                                                                                                                                                                                                                                                                                                                                                                 |         |
| 292E                                                                                                                                         |     | Ultra320 SCSI 4-Pack for disk mirroring backplane                                                                                                                                                                                                                          | ESCALA PL 450T/R, ESCALA PL 450T/R+ or ESCALA PL 850T/R-L+, 9406-550, 7/20                                                                                                                                                                                                                                                                                                                                                                                                                                                                                                                                                                                                                                                                                                                                                                                                                                                                                                                      | 03N5880 |
|                                                                                                                                              | 199 | Disk drive backplane                                                                                                                                                                                                                                                       | 11D/20                                                                                                                                                                                                                                                                                                                                                                                                                                                                                                                                                                                                                                                                                                                                                                                                                                                                                                                                                                                          | 53P0257 |
| <b>Media backplanes:</b>                                                                                                                     |     |                                                                                                                                                                                                                                                                            |                                                                                                                                                                                                                                                                                                                                                                                                                                                                                                                                                                                                                                                                                                                                                                                                                                                                                                                                                                                                 |         |
| 28D1                                                                                                                                         |     | Media backplane                                                                                                                                                                                                                                                            | 112/85, ESCALA PL 250T/R, ESCALA PL 450T/R, ESCALA PL 250T/R+ or ESCALA PL 450T/R-L+, ESCALA PL 450T/R+ or ESCALA PL 850T/R-L+, 7/20                                                                                                                                                                                                                                                                                                                                                                                                                                                                                                                                                                                                                                                                                                                                                                                                                                                            | 03N6005 |
| 28DC                                                                                                                                         |     | Media backplane                                                                                                                                                                                                                                                            | ESCALA PL 1650R-L+, ESCALA PL 850R/PL 1650R/R+, 9406-570                                                                                                                                                                                                                                                                                                                                                                                                                                                                                                                                                                                                                                                                                                                                                                                                                                                                                                                                        | 03N4808 |
| 291E                                                                                                                                         |     | Media backplane, SCSI                                                                                                                                                                                                                                                      | 9405-520, 9406-520                                                                                                                                                                                                                                                                                                                                                                                                                                                                                                                                                                                                                                                                                                                                                                                                                                                                                                                                                                              | 80P4179 |
| <b>Failing function codes (FFC)</b>                                                                                                          |     |                                                                                                                                                                                                                                                                            |                                                                                                                                                                                                                                                                                                                                                                                                                                                                                                                                                                                                                                                                                                                                                                                                                                                                                                                                                                                                 |         |
| The following entries are listed according to the FFC. Follow the links or use the preceding tables for FRU part numbers for on your server. |     |                                                                                                                                                                                                                                                                            |                                                                                                                                                                                                                                                                                                                                                                                                                                                                                                                                                                                                                                                                                                                                                                                                                                                                                                                                                                                                 |         |
|                                                                                                                                              | 227 | ISA/PCI bus logic problem (System backplane or I/O backplane if present)                                                                                                                                                                                                   | Select the appropriate server for the unit on which you are working: <ul style="list-style-type: none"> <li>• <a href="#">Model ESCALA PL 245T/R backplanes</a></li> <li>• <a href="#">Model ESCALA PL 250R-VL or ESCALA PL 450R-XS backplanes</a></li> <li>• <a href="#">Model ESCALA PL 250R-L and ESCALA PL 250R-L+ or ESCALA PL 450R-VL+ backplanes</a></li> <li>• <a href="#">Model ESCALA PL 250T/R, ESCALA PL 250T/R+ or ESCALA PL 450T/R-L+, backplanes</a></li> <li>• <a href="#">Model ESCALA PL 450T/R, ESCALA PL 450T/R+ or ESCALA PL 850T/R-L+, backplanes</a></li> <li>• <a href="#">Model ESCALA PL 1650R-L+ and ESCALA PL 850R/PL 1650R/R+ backplanes</a></li> <li>• <a href="#">Model 5/75 backplanes</a></li> <li>• <a href="#">Model ESCALA PL 3250R and ESCALA PL 6450R backplanes</a></li> <li>• <a href="#">Model 7/10 backplanes</a></li> <li>• <a href="#">Model 11D/10, 11D/11, and 57/90 backplanes</a></li> <li>• <a href="#">Model 11D/20 backplanes</a></li> </ul> |         |
|                                                                                                                                              | 2C4 | System bus connector problem (system backplane), see the preceding <a href="#">Backplane parts</a> tables for the unit on which you are working.<br><br>For internal signal and power cables and external cables, see <a href="#">Cables</a> .                             | ESCALA PL 250T/R, ESCALA PL 450T/R, ESCALA PL 850R/PL 1650R/R+                                                                                                                                                                                                                                                                                                                                                                                                                                                                                                                                                                                                                                                                                                                                                                                                                                                                                                                                  |         |
|                                                                                                                                              | 2C8 | Mezzanine bus problem (internal signal or power cables, system backplane, or I/O backplane).<br><br>For internal signal and power cables and external cables, see <a href="#">Cables</a> .<br><br>See the preceding <a href="#">Backplane parts</a> tables for the unit on | ESCALA PL 250T/R, ESCALA PL 450T/R, ESCALA PL 850R/PL 1650R/R+                                                                                                                                                                                                                                                                                                                                                                                                                                                                                                                                                                                                                                                                                                                                                                                                                                                                                                                                  |         |

Service provider information

|  |     |                                                                                                                                                      |                                                                |         |
|--|-----|------------------------------------------------------------------------------------------------------------------------------------------------------|----------------------------------------------------------------|---------|
|  |     | which you are working.                                                                                                                               |                                                                |         |
|  |     | I/O drawer backplane, for backplanes, see the preceding <a href="#">Backplane parts</a> tables for the unit on which you are working.                |                                                                | 09P5921 |
|  |     | PCI backplane (planar), for backplanes, see the preceding <a href="#">Backplane parts</a> tables for the unit on which you are working.              | 11D/20                                                         | 39J0515 |
|  | 2C9 | PCI bus problem (I/O backplane or system backplane), see the preceding <a href="#">Backplane parts</a> tables for the unit on which you are working. | ESCALA PL 250T/R, ESCALA PL 450T/R, ESCALA PL 850R/PL 1650R/R+ |         |
|  |     | I/O drawer backplane, see the preceding <a href="#">Backplane parts</a> tables for the unit on which you are working.                                |                                                                | 09P5921 |
|  |     | PCI backplane (planar), see the preceding <a href="#">Backplane parts</a> tables for the unit on which you are working.                              | 11D/20                                                         | 39J0515 |
|  | 2D1 | ISA bus problem (I/O backplane or system backplane), see the preceding <a href="#">Backplane parts</a> tables for the unit on which you are working. | ESCALA PL 250T/R, ESCALA PL 450T/R, ESCALA PL 850R/PL 1650R/R+ |         |
|  | 2D2 | Mezzanine bus arbiter problem (I/O backplane), see the preceding <a href="#">Backplane parts</a> tables for the unit on which you are working.       | ESCALA PL 250T/R, ESCALA PL 450T/R, ESCALA PL 850R/PL 1650R/R+ |         |
|  |     | I/O drawer backplane, see the preceding <a href="#">Backplane parts</a> tables for the unit on which you are working.                                |                                                                | 09P5921 |
|  |     | PCI backplane (planar), see the preceding <a href="#">Backplane parts</a> tables for the unit on which you are working.                              | 11D/20                                                         | 39J0515 |
|  | 2D9 | Power controller problem (I/O backplane), see the preceding <a href="#">Backplane parts</a> tables for the unit on which you are working.            | ESCALA PL 250T/R, ESCALA PL 450T/R, ESCALA PL 850R/PL 1650R/R+ |         |
|  |     | I/O drawer backplane, see the preceding <a href="#">Backplane parts</a> tables for the unit on which you are working.                                |                                                                | 09P5921 |
|  |     | PCI planar                                                                                                                                           | 11D/20                                                         | 39J0515 |
|  | 2E0 | Fan sensor problem (I/O backplane).<br><br>See the preceding tables for the server or expansion unit on which you are working.                       | ESCALA PL 250T/R, ESCALA PL 450T/R, ESCALA PL 850R/PL 1650R/R+ |         |
|  |     | I/O drawer backplane                                                                                                                                 |                                                                | 09P5921 |

Service provider information

|  |                                     |                                                                                                                                          |                                                                |         |
|--|-------------------------------------|------------------------------------------------------------------------------------------------------------------------------------------|----------------------------------------------------------------|---------|
|  |                                     | PCI planar                                                                                                                               | 11D/20                                                         | 39J0515 |
|  | 2E1                                 | Thermal sensor problem (I/O backplane).<br><br>See the preceding tables for the server or expansion unit on which you are working.       | ESCALA PL 250T/R, ESCALA PL 450T/R, ESCALA PL 850R/PL 1650R/R+ |         |
|  |                                     | I/O drawer backplane                                                                                                                     |                                                                | 09P5921 |
|  |                                     | PCI Planar                                                                                                                               | 11D/20                                                         | 39J0515 |
|  | 2E2                                 | Voltage sensor problem (I/O backplane).<br><br>See the preceding tables for the server or expansion unit on which you are working.       | ESCALA PL 250T/R, ESCALA PL 450T/R, ESCALA PL 850R/PL 1650R/R+ |         |
|  |                                     | I/O drawer backplane                                                                                                                     |                                                                | 09P5921 |
|  |                                     | PCI planar                                                                                                                               | 11D/20                                                         | 39J0515 |
|  | 2E6 (Also see <a href="#">2E6</a> ) | I/O drawer backplane                                                                                                                     |                                                                | 09P5921 |
|  |                                     | PCI planar                                                                                                                               | 11D/20                                                         | 39J0515 |
|  | 307                                 | Expansion unit logic problem (I/O backplane).<br><br>See the preceding tables for the server or expansion unit on which you are working. | ESCALA PL 250T/R, ESCALA PL 450T/R, ESCALA PL 850R/PL 1650R/R+ |         |
|  |                                     | I/O drawer backplane                                                                                                                     |                                                                | 09P5921 |
|  |                                     | PCI planar                                                                                                                               | 11D/20                                                         | 39J0515 |
|  | 814, 825                            | NIO planar                                                                                                                               | 9076/POWER3 SMP High Node                                      | 11K0571 |

**Processor parts**

| CCIN | Failing Function Code | Description                               | Model, expansion unit, or unit type                                                                                                                                                   | Part number                                                         |
|------|-----------------------|-------------------------------------------|---------------------------------------------------------------------------------------------------------------------------------------------------------------------------------------|---------------------------------------------------------------------|
|      |                       | Processors                                | ESCALA PL 245T/R, ESCALA PL 250R-VL or ESCALA PL 450R-XS, ESCALA PL 250R-L, ESCALA PL 250R-L+ or ESCALA PL 450R-VL+, ESCALA PL 250T/R+ or ESCALA PL 450T/R-L+, ESCALA PL 250T/R, 7/10 | Replace the system backplane (see <a href="#">Backplane parts</a> ) |
| 26D9 | 282, 2C4, 308         | 1.9 GHz, DDR1 POD processor card, 0-2 way | ESCALA PL 850R/PL 1650R/R+                                                                                                                                                            | 03N5804                                                             |
| 26DA | 282, 2C4, 308         | 1.9 GHz DDR2 POD processor card, 0-2 way  | ESCALA PL 850R/PL 1650R/R+                                                                                                                                                            | 03N4519                                                             |
| 26EA | 282, 2C4, 308         | 1.65 GHz DDR1 POD processor card, 0-2 way | 9406-570                                                                                                                                                                              | 80P4993                                                             |
| 26EB |                       |                                           | ESCALA PL 850R/PL 1650R/R+                                                                                                                                                            | 03N5803                                                             |

Service provider information

|      |               |                                                                                                     |                                                                      |         |
|------|---------------|-----------------------------------------------------------------------------------------------------|----------------------------------------------------------------------|---------|
|      | 282, 2C4, 308 | 1.9 GHz DDR1 POD processor card, 0-2 way, low voltage                                               |                                                                      |         |
| 26EF | 282, 2C4, 308 | 1.5 GHz DDR1 processor card, 2 way                                                                  | ESCALA PL 850R/PL 1650R/R+                                           | 03N5801 |
| 26F0 | 282, 2C4, 308 | 1.5 GHz processor card, 1 way                                                                       | 7/20                                                                 | 10N6458 |
| 26F1 | 282, 2C4, 308 | 1.65 GHz processor card, 2 way                                                                      | 7/20                                                                 | 10N6843 |
| 26F2 | 282, 2C4, 308 | 1.65 GHz DDR1 POD processor card, 0-2 way                                                           | ESCALA PL 850R/PL 1650R/R+, 9406-570                                 | 03N5802 |
| 28D7 |               | Service processor card                                                                              | 9405-520, 9406-520, ESCALA PL 250T/R                                 | 03P5827 |
| 28DE |               | Service processor card                                                                              | ESCALA PL 3250R, ESCALA PL 6450R, 9406-595                           | 60H2214 |
| 28E4 |               | Oscillator card                                                                                     | ESCALA PL 3250R, ESCALA PL 6450R                                     | 39J2750 |
| 28E6 |               | Multiplexer (MUX) card                                                                              | ESCALA PL 3250R, ESCALA PL 6450R                                     | 41U0371 |
| 28EA |               | Service processor card                                                                              | 9406-570, ESCALA PL 850R/PL 1650R/R+                                 | 03N6603 |
| 291A |               | Light panel assembly, front                                                                         | ESCALA PL 6450R, 9406-595                                            | 41V0964 |
| 291B |               | Light panel assembly, back                                                                          | ESCALA PL 6450R, 9406-595                                            | 41V0965 |
| 293A |               | FSP                                                                                                 | 112/85, ESCALA PL 250T/R+ or ESCALA PL 450T/R-L+, 9405-520, 9406-520 | 03N5830 |
| 29AB | 282, 2C4, 308 | 1.9 GHz, DDR2 POD processor card, 0-2 way, low voltage                                              | ESCALA PL 850R/PL 1650R/R+                                           | 03N5819 |
| 5237 | 282, 2C4, 308 | 1.65 GHz processor card, 0-2 way                                                                    | 9406-550, ESCALA PL 450T/R                                           | 10N6456 |
| 523A |               | 1.5 GHz processor card, 1 way                                                                       | ESCALA PL 450T/R                                                     | 10N6837 |
| 523B |               | 1.5 GHz processor card, 0-2 way                                                                     | ESCALA PL 450T/R                                                     | 10N6454 |
| 528C |               | 1.9 GHz processor card, 0-16 way, MCM kit                                                           | ESCALA PL 6450R                                                      | 60H2388 |
| 52A4 |               | 1.65 GHz processor card, 0-16 way, MCM kit                                                          | ESCALA PL 3250R, ESCALA PL 6450R, 9406-595                           | 60H2387 |
| 523A | 282, 2C4, 308 | 1.5 GHz processor card, 1 way                                                                       | ESCALA PL 450T/R                                                     | 10N6837 |
| 523B | 282, 2C4, 308 | 1.5 GHz DDR1 processor card, 2 way                                                                  | ESCALA PL 450T/R                                                     | 10N6454 |
| 523D | 282, 2C4, 308 | 1.5 GHz processor card, 2 way                                                                       | 7/20                                                                 | 80P6315 |
| 7781 | 282, 2C4, 308 | 1.5 GHz DDR2 POD processor card, 4 way                                                              | ESCALA PL 1650R-L+                                                   | 42R5241 |
| 7782 | 282, 2C4, 308 | 1.9 GHz, DDR2 POD processor card, 0-2 way. Requires minimum System Firmware level of SF240_201_201. |                                                                      | 42R5232 |
| 831A |               | 1.65 GHz DDR2 processor card, 0-2 way                                                               |                                                                      | 10N6463 |
| 8312 | 282, 2C4, 308 | 1.9 GHz DDR2 processor card, 2 way                                                                  | ESCALA PL 450T/R+ or ESCALA PL 850T/R-L+, 9406-550                   | 10N6466 |
| 8313 |               | 1.5 GHz DDR2 processor card, 0-4 way                                                                | ESCALA PL 450T/R+ or ESCALA PL 850T/R-L+                             | 10N6469 |
|      | 185           | X.25 interface coprocessor adapter                                                                  |                                                                      | 71G6458 |

## Service provider information

|     |                                                                                                                                                                               |                                                                |                               |
|-----|-------------------------------------------------------------------------------------------------------------------------------------------------------------------------------|----------------------------------------------------------------|-------------------------------|
| 186 | Coprocessor multiport adapter, model 2 daughter card<br>1 MB memory module                                                                                                    |                                                                | 33F8967<br>84F7540<br>53F2662 |
| 210 | Fixed point processor problem (system board, CPU card)                                                                                                                        | ESCALA PL 250T/R, ESCALA PL 450T/R, ESCALA PL 850R/PL 1650R/R+ |                               |
| 2D3 | Service processor card                                                                                                                                                        | ESCALA PL 250T/R, ESCALA PL 450T/R, ESCALA PL 850R/PL 1650R/R+ |                               |
| 2D6 | Service processor (I/O planar, system board)                                                                                                                                  | ESCALA PL 250T/R, ESCALA PL 450T/R, ESCALA PL 850R/PL 1650R/R+ |                               |
| 2E8 | Processor card                                                                                                                                                                | ESCALA PL 250T/R, ESCALA PL 450T/R, ESCALA PL 850R/PL 1650R/R+ |                               |
| 67B | PCI cryptographic coprocessor card                                                                                                                                            |                                                                | 10J0593                       |
| 780 | X.25 interface coprocessor adapter                                                                                                                                            |                                                                | 40H1937                       |
| 781 | Coprocessor multiport adapter, model 2 Ddaughter coprocessor multiport adapter, model 2 (Bbase)<br><br><b>Note:</b> Replace the daughter card before replacing the base card. |                                                                | 84F7540<br>33F8967            |
| 811 | Processor complex being identified.                                                                                                                                           |                                                                |                               |
| 814 | Service processor card problem<br><br><b>Note:</b> Unless listed, refer to FFC 221 for type/model and FRU information.                                                        |                                                                |                               |
| 815 | Floating point processor problem<br><br><b>Note:</b> For type/model and FRU information refer to FFC 210.                                                                     |                                                                |                               |
| 820 | Interprocessor related testing problem<br><br><b>Note:</b> For type/model and FRU information, if not listed here, refer to FFC 221.                                          |                                                                |                               |

Service provider information

|      |      |                                                                                                    |  |         |
|------|------|----------------------------------------------------------------------------------------------------|--|---------|
|      | B69  | Coprocessor multiport adapter, model 2 (0 MB)                                                      |  | 3F8967  |
|      | 2521 | Processor subsystem chassis (with backplane and DASD ribbon cable)                                 |  | 44P3988 |
|      |      | 1.9 GHz POD processor module, 0-8 way                                                              |  | 60H2389 |
| 8338 |      | 2.2 GHz DDR2 POD processor card, 0-2 way. Requires minimum System Firmware level of SF240_201_201. |  | 39J4646 |
|      |      | 1.9 GHz processor card, 16 way, 288 MB L3 cache                                                    |  | 03N7071 |
|      |      | 2.2 GHz processor card, 8 way, GS                                                                  |  | 03N7070 |

Bus parts

| CCIN | Failing Function Code | Description                                    | Model, expansion unit, or unit type                                        | Part number |
|------|-----------------------|------------------------------------------------|----------------------------------------------------------------------------|-------------|
| 1800 |                       | RIO card (copper)                              | 9406-570, ESCALA PL 850R/PL 1650R/R+                                       | 39J0792     |
| 1801 |                       | RIO card (optical)                             | ESCALA PL 850R/PL 1650R/R+                                                 | 97P6878     |
| 1806 |                       | RIO card (copper)                              | ESCALA PL 450T/R+ or ESCALA PL 850T/R-L+, 9406-550, ESCALA PL 450T/R, 7/20 | 03N6658     |
| 1807 |                       | RIO card (optical)                             | 9406-550                                                                   | 42R4660     |
| 2691 |                       | HSL I/O bridge                                 | 9405-520, 9406-520, 9406-550, 9406-570, 9406-595                           | 04N6907     |
| 2739 |                       | Optical bus adapter                            | 50/74, 50/79, 5078, 0578                                                   | 53P1405     |
| 2779 |                       | Bus adapter                                    | All                                                                        | 21P5342     |
| 2886 |                       | Bus adapter with two external ports (optical)  | , ,                                                                        | 39J0669     |
| 2887 |                       | RIO card (bus adapter with two external ports) | , , , , , ,                                                                | 39J0527     |
| 2888 |                       | HSL card                                       | , ,                                                                        | 39J2923     |
| 28D8 |                       | RIO card                                       | ESCALA PL 3250R, ESCALA PL 6450R, 9406-595                                 | 10N7269     |
| 28EE |                       | Switch interface adapter                       | ,                                                                          | 12R9350     |
| 28E7 |                       | RIO-2 card                                     | 05/95, 50/94, 50/95, 52/94, 8094, 82/94, 91/94, 11D/20                     | 39J0253     |
| 28EB |                       | RIO card (optical)                             | 9406-595                                                                   | 00P3579     |
| 28FF |                       | RIO card                                       | 57/90, 11D/11                                                              | 03N5633     |

## Cables

See [Cables](#).

| CCIN | Failing Function Code | Description                                                                          | Model, expansion unit, or unit type                            | Part number        |
|------|-----------------------|--------------------------------------------------------------------------------------|----------------------------------------------------------------|--------------------|
|      | 190                   | Internal disk signal cable                                                           | 9406-520, 9406-550, 9406-570, 9406-595                         | 21P7063            |
|      | 251                   | Cables, parallel printer                                                             |                                                                | 8529214<br>8185219 |
|      | 252                   | Standard 9-pin to 25-pin converter cable                                             |                                                                | 23R4632            |
|      | 253                   | Cable, multiprotocol, EIA-422A, (customer-provided)                                  |                                                                |                    |
|      | 254                   | Cable, 4-port multiprotocol EIA-232, V.24                                            |                                                                | 71F0165            |
|      | 256                   | Cable, token-ring, 10 ft. (3.04 m)                                                   |                                                                | 6339098            |
|      | 257                   | Cable, 4-port multiprotocol, V.35                                                    |                                                                | 71F0162            |
|      | 258                   | 4-port multiprotocol cable                                                           |                                                                | 40F9897            |
|      | 259                   | Cable, async EIA-232D, V.24                                                          |                                                                | 42R5206            |
|      | 260                   | Cable, 4-port multiprotocol, X.21                                                    |                                                                | 71F0164            |
|      | 262                   | 8-port multiport interface cable                                                     |                                                                | 00F5524            |
|      | 263                   | Terminal cable, EIA-232                                                              |                                                                | 12H1204            |
|      | 266                   | RJ-45 to DB-25 converter cable                                                       |                                                                | 59F3432            |
|      | 267                   | Cable assembly, 4-port multiprotocol jumper                                          |                                                                | 81F8570            |
|      | 271                   | Cable, X.25 attachment cable, X.21 (3 m)<br>cable, X.25 attachment cable, X.21 (6 m) |                                                                | 07F3151<br>53F3926 |
|      | 272                   | Cable, X.25 attachment cable, V.24 (3 m)<br>cable, X.25 attachment cable, V.24 (6 m) |                                                                | 07F3160<br>53F3927 |
|      | 273                   | Cable, X.25 attachment cable, V.35 (3 m)<br>cable, X.25 attachment cable, V.35 (6 m) |                                                                | 07F3171<br>53F3928 |
|      | 276                   | Cable, SCSI controller cable                                                         |                                                                | 31F4221            |
|      | 277                   | Internal SCSI signal cable problem                                                   | ESCALA PL 250T/R, ESCALA PL 450T/R, ESCALA PL 850R/PL 1650R/R+ |                    |
|      | 2C3                   |                                                                                      |                                                                |                    |

Service provider information

|  |     |                                                                                                                                                                                                                                                                                       |                                                                |                                                                           |
|--|-----|---------------------------------------------------------------------------------------------------------------------------------------------------------------------------------------------------------------------------------------------------------------------------------------|----------------------------------------------------------------|---------------------------------------------------------------------------|
|  |     | 2-Port multiprotocol adapter cable V.24<br>2-Port multiprotocol adapter cable V.35<br>2-Port multiprotocol adapter cable V.36<br>2-Port multiprotocol adapter cable X.21                                                                                                              |                                                                | 93H5263<br>93H5264<br>93H5265<br>93H5267                                  |
|  | 306 | RIO I/O cable                                                                                                                                                                                                                                                                         | ESCALA PL 250T/R, ESCALA PL 450T/R, ESCALA PL 850R/PL 1650R/R+ |                                                                           |
|  | 736 | Quiet touch keyboard and speaker cable<br><br><b>Note:</b> The part number is printed on the underside of the keyboard.                                                                                                                                                               |                                                                |                                                                           |
|  | 922 | Keyboard cable                                                                                                                                                                                                                                                                        |                                                                | 1394609                                                                   |
|  | B54 | 128-port async controller cable, 0.2m (9 in.)<br><br>128-port async controller cable, 4.6m (15 ft.)                                                                                                                                                                                   |                                                                | 43G0936<br><br>43G0937                                                    |
|  | B81 | Coprocessor multiport interface cable                                                                                                                                                                                                                                                 |                                                                | 40F9897                                                                   |
|  | B82 | Coprocessor multiport V.35 cable                                                                                                                                                                                                                                                      |                                                                | 71F0162                                                                   |
|  | B83 | Coprocessor multiport X.21 cable                                                                                                                                                                                                                                                      |                                                                | 71F0164                                                                   |
|  | C22 | RJ-45 to DB25 converter cable kit                                                                                                                                                                                                                                                     |                                                                | 94H0779                                                                   |
|  | C24 | Fiber optic cables for PCI Fibre Channel adapter (6.7 m and 12.8 m)                                                                                                                                                                                                                   |                                                                | 54G3384<br>55G3384                                                        |
|  | C36 | Attachment adapter cable                                                                                                                                                                                                                                                              |                                                                | 65G4892                                                                   |
|  | C44 | VOO/RSS crossover cable                                                                                                                                                                                                                                                               |                                                                | 65G4894                                                                   |
|  | C98 | ARTIC960 4-port selectable EIA-232 cable<br>ARTIC960 4-port selectable RS-449 cable<br>ARTIC960 4-port selectable X.21 cable<br>ARTIC960 4-port selectable V.35 cable<br>ARTIC960 4-port selectable EIA-530 cable<br>ARTIC960 4-port T1 RJ-45 cable<br>ARTIC960 4-port E1 RJ-45 cable |                                                                | 87H3405<br>87H3396<br>87H3408<br>87H3399<br>87H3402<br>87H3518<br>87H3515 |



Service provider information

|  |      |                                                                                                                            |                                                                                                                                                                                                                                                                                                                                                     |                    |
|--|------|----------------------------------------------------------------------------------------------------------------------------|-----------------------------------------------------------------------------------------------------------------------------------------------------------------------------------------------------------------------------------------------------------------------------------------------------------------------------------------------------|--------------------|
|  |      | <b>Note:</b> A wrap plug is shipped with each adapter and cable.                                                           |                                                                                                                                                                                                                                                                                                                                                     |                    |
|  | D46  | Token-ring 9-pin D-shell cable, 3m (10 ft.)                                                                                |                                                                                                                                                                                                                                                                                                                                                     | 6339098            |
|  |      | Token-ring RJ-45 STP cable, 3m (10 ft.)<br><br><b>Note:</b> Not used with the high-speed token-ring PCI adapter            |                                                                                                                                                                                                                                                                                                                                                     | 60G1063            |
|  |      | RJ-45 to 9-pin D-shell token-ring conversion cable<br><br><b>Note:</b> Not used with the high-speed token-ring PCI adapter |                                                                                                                                                                                                                                                                                                                                                     | 93H8894            |
|  |      | Standard UTP RJ-45 cable                                                                                                   |                                                                                                                                                                                                                                                                                                                                                     | OEM cable          |
|  | D56  | EIA-232E printer/terminal serial cable                                                                                     |                                                                                                                                                                                                                                                                                                                                                     | 12H1204            |
|  | D57  | 8-Port multiport interface cable ISA async adapter                                                                         |                                                                                                                                                                                                                                                                                                                                                     | 07L9822            |
|  | E22  | Video cable (generic)                                                                                                      |                                                                                                                                                                                                                                                                                                                                                     |                    |
|  | E23  | Audio cable (generic)                                                                                                      |                                                                                                                                                                                                                                                                                                                                                     |                    |
|  | 2D00 | Cable, DASD 50 pins<br>DASD backplane                                                                                      |                                                                                                                                                                                                                                                                                                                                                     | 09P5895<br>00P2983 |
|  |      | Operator panel cable                                                                                                       | ESCALA PL 245T/R, 471/85                                                                                                                                                                                                                                                                                                                            | 39J4135            |
|  |      | IEA-232 cable                                                                                                              | ESCALA PL 245T/R, ESCALA PL 250R-VL or ESCALA PL 450R-XS, ESCALA PL 250R-L, ESCALA PL 250R-L+ or ESCALA PL 450R-VL+, ESCALA PL 250T/R+ or ESCALA PL 450T/R-L+, 9405-520, 9406-520, ESCALA PL 250T/R, ESCALA PL 450T/R+ or ESCALA PL 850T/R-L+, 9406-550, ESCALA PL 450T/R, ESCALA PL 1650R-L+, 9406-570, ESCALA PL 850R/PL 1650R/R+, 9406-595, 7/20 | 12H1204            |
|  |      | Analog monitor cable, 17"                                                                                                  | ESCALA PL 245T/R, ESCALA PL 250R-VL or ESCALA PL 450R-XS, ESCALA PL 250R-L, ESCALA PL 250R-L+ or ESCALA PL 450R-VL+, ESCALA PL 250T/R+ or ESCALA PL 450T/R-L+, 9405-520, 9406-520, ESCALA PL 250T/R, ESCALA PL 450T/R+ or ESCALA PL 850T/R-L+, 9406-550, ESCALA PL 450T/R, ESCALA PL 1650R-L+, 9406-570, ESCALA PL 850R/PL 1650R/R+, 185/75         | 30R5047            |
|  |      | Analog monitor cable, 15"                                                                                                  | ESCALA PL 245T/R, ESCALA PL 250R-VL or ESCALA PL 450R-XS, ESCALA PL 250R-L+ or ESCALA PL                                                                                                                                                                                                                                                            | 40K5344            |

Service provider information

|  |  |                                                       |                                                                                                                                                                                                                                                                                                                                                     |         |
|--|--|-------------------------------------------------------|-----------------------------------------------------------------------------------------------------------------------------------------------------------------------------------------------------------------------------------------------------------------------------------------------------------------------------------------------------|---------|
|  |  |                                                       | 450R-VL+, ESCALA PL 250T/R+ or ESCALA PL 450T/R-L+, 9405-520, 9406-520, ESCALA PL 250T/R, ESCALA PL 450T/R+ or ESCALA PL 850T/R-L+, 9406-550, ESCALA PL 450T/R, ESCALA PL 1650R-L+, 9406-570, ESCALA PL 850R/PL 1650R/R+, 9406-595, 7/20                                                                                                            |         |
|  |  | IDE cable                                             | ESCALA PL 245T/R, 471/85                                                                                                                                                                                                                                                                                                                            | 39J4137 |
|  |  | Controller cable                                      | ESCALA PL 245T/R, 471/85                                                                                                                                                                                                                                                                                                                            | 39J4136 |
|  |  | Cable 9-25 pin                                        | ESCALA PL 245T/R, ESCALA PL 250R-VL or ESCALA PL 450R-XS, ESCALA PL 250R-L, ESCALA PL 250R-L+ or ESCALA PL 450R-VL+, ESCALA PL 250T/R+ or ESCALA PL 450T/R-L+, 9405-520, 9406-520, ESCALA PL 450T/R+ or ESCALA PL 850T/R-L+, 9406-550, ESCALA PL 450T/R, ESCALA PL 1650R-L+, 9406-570, ESCALA PL 850R/PL 1650R/R+, 9406-595, 7/20                   | 23R4632 |
|  |  | Converter cable, VHDCI to P, mini 68 pin to 68 pin    | ESCALA PL 245T/R, ESCALA PL 250R-VL or ESCALA PL 450R-XS, ESCALA PL 250R-L, ESCALA PL 250R-L+ or ESCALA PL 450R-VL+, ESCALA PL 250T/R+ or ESCALA PL 450T/R-L+, 9405-520, 9406-520, ESCALA PL 250T/R, ESCALA PL 450T/R+ or ESCALA PL 850T/R-L+, 9406-550, ESCALA PL 450T/R, ESCALA PL 1650R-L+, 9406-570, ESCALA PL 850R/PL 1650R/R+, 9406-595, 7/20 | 01K6497 |
|  |  | Cable (fiber), LC(M)/SC(F) 62.5 micron converter, 2 M | ESCALA PL 245T/R, ESCALA PL 250R-VL or ESCALA PL 450R-XS, ESCALA PL 250R-L, ESCALA PL 250R-L+ or ESCALA PL 450R-VL+, ESCALA PL 250T/R+ or ESCALA PL 450T/R-L+, 9405-520, 9406-520, ESCALA PL 250T/R, ESCALA PL 450T/R+ or ESCALA PL 850T/R-L+, 9406-550, ESCALA PL 450T/R, ESCALA PL 1650R-L+, 9406-570, ESCALA PL 850R/PL 1650R/R+, 9406-595, 7/20 | 01K6497 |
|  |  | Digital cable, 6736-HB0 and 9180 monitors             | ESCALA PL 245T/R, ESCALA PL 250R-VL or ESCALA PL 450R-XS, ESCALA PL 250R-L, ESCALA PL 250R-L+ or ESCALA PL 450R-VL+, ESCALA PL 250T/R+ or ESCALA PL 450T/R-L+, 9405-520, 9406-520, ESCALA PL 250T/R, ESCALA PL 450T/R+ or ESCALA PL 850T/R-L+, 9406-550, ESCALA PL 450T/R, ESCALA PL 1650R-L+, 9406-570, ESCALA PL 850R/PL 1650R/R+, 9406-595, 7/20 | 31P9266 |
|  |  | Digital monitor cable                                 | ESCALA PL 245T/R, ESCALA PL 250R-VL or ESCALA PL 450R-XS, ESCALA PL 250R-L+ or ESCALA PL 450R-VL+, ESCALA PL 250T/R+ or ESCALA PL 450T/R-L+, 9405-520, 9406-520, ESCALA PL 250T/R, ESCALA PL 450T/R+ or ESCALA PL 850T/R-L+, 9406-550, ESCALA PL 450T/R, ESCALA PL 1650R-L+, 9406-570, ESCALA PL 850R/PL 1650R/R+, 9406-595, 7/20                   | 40K5345 |



Service provider information

|  |  |                    |                   |         |
|--|--|--------------------|-------------------|---------|
|  |  | Cable              | , ,               | 41V0835 |
|  |  | 10 meter HSL cable | , , , , ,         | 39J2551 |
|  |  | SCSI cable         | , , , , , , , , , | 42R4051 |

Control panel parts

| CCIN | Failing Function Code | Description                                     | Model, expansion unit, or unit type                                                                                                                                                                        | Part number |
|------|-----------------------|-------------------------------------------------|------------------------------------------------------------------------------------------------------------------------------------------------------------------------------------------------------------|-------------|
| 247B | 165                   | Control panel                                   | 9405-520, 9406-520, 9406-550, 9406-570, 9406-595                                                                                                                                                           | 24L0962     |
| 250C |                       | Control panel                                   | 9405-520, 9406-520, 9406-550, 9406-570, 9406-595                                                                                                                                                           | 53P0330     |
| 291D |                       | Control panel                                   | 112/85, ESCALA PL 250R-VL or ESCALA PL 450R-XS, ESCALA PL 250T/R+ or ESCALA PL 450T/R-L+, 9405-520, 9406-520, ESCALA PL 250T/R, ESCALA PL 450T/R+ or ESCALA PL 850T/R-L+, 9406-550, ESCALA PL 450T/R, 7/20 | 39J3273     |
| 28D4 |                       | Control panel                                   | 9406-570, ESCALA PL 850R/PL 1650R/R+                                                                                                                                                                       | 39J3272     |
| 292F |                       | Control panel and removable media tray assembly | ESCALA PL 250R-L, 7/10                                                                                                                                                                                     | 42R5760     |
|      |                       | Control panel and removable media tray assembly |                                                                                                                                                                                                            | 39J2179     |
|      |                       | Operator panel                                  | , , , , , , , , ,                                                                                                                                                                                          | 39J3273     |
|      |                       | Control panel                                   |                                                                                                                                                                                                            | 39J3087     |

Disk unit parts

| CCIN | Failing Function Code | Description      | Model, expansion unit, or unit type | Part number |
|------|-----------------------|------------------|-------------------------------------|-------------|
| 4326 |                       | 35 GB disk drive | , , , , ,                           | 39J3695     |

Service provider information

|      |     |                                                                                                                    |                                                                                                                                                                                                                                                                                                                                           |                    |
|------|-----|--------------------------------------------------------------------------------------------------------------------|-------------------------------------------------------------------------------------------------------------------------------------------------------------------------------------------------------------------------------------------------------------------------------------------------------------------------------------------|--------------------|
|      |     |                                                                                                                    |                                                                                                                                                                                                                                                                                                                                           | 97P2990            |
| 4327 |     | 60 GB disk drive                                                                                                   | , , , , ,                                                                                                                                                                                                                                                                                                                                 | 39J3696            |
| 4328 |     | 140 GB disk drive                                                                                                  | , , , , ,                                                                                                                                                                                                                                                                                                                                 | 39J3697<br>97P2993 |
| 6600 |     | Disk unit and carrier. Remove the disk unit from the system to determine the part number of the failing component. | All                                                                                                                                                                                                                                                                                                                                       | N/A                |
| 6607 |     | 4 GB disk drive                                                                                                    | All                                                                                                                                                                                                                                                                                                                                       | 44L0061            |
| 6713 |     | 9 GB disk drive                                                                                                    | All                                                                                                                                                                                                                                                                                                                                       | 44L0062            |
| 6714 |     | Disk unit and carrier                                                                                              | All                                                                                                                                                                                                                                                                                                                                       | 44L0063            |
| 6717 |     | Disk unit and carrier                                                                                              | All                                                                                                                                                                                                                                                                                                                                       | 97H7332            |
| 6718 |     | Disk unit and carrier                                                                                              | All                                                                                                                                                                                                                                                                                                                                       | 04N2737            |
| 6719 |     | Disk unit and carrier                                                                                              | All                                                                                                                                                                                                                                                                                                                                       | 04N4638            |
|      | 141 | 857 MB disk enclosure assembly                                                                                     |                                                                                                                                                                                                                                                                                                                                           | 4569502            |
|      | 440 | 9.1 GB ultra SCSI disk drive only                                                                                  |                                                                                                                                                                                                                                                                                                                                           | 25L3101            |
|      | 441 | 18.2 GB ultra SCSI disk drive only                                                                                 |                                                                                                                                                                                                                                                                                                                                           | 25L3100            |
|      | 442 | 9.1 GB ultra LVD SCSI disk drive                                                                                   |                                                                                                                                                                                                                                                                                                                                           | 09L3117            |
|      | 443 | 18.2 GB ultra LVD SCSI disk drive                                                                                  |                                                                                                                                                                                                                                                                                                                                           | 09L3118            |
|      | 446 | 300 GB Ultra320 10K RPM SCSI disk drive/carrier                                                                    |                                                                                                                                                                                                                                                                                                                                           | 03N5270            |
|      | 451 | When replacing a 73 GB SCSI disk drive in an o/p system, go to <a href="#">451</a> .                               |                                                                                                                                                                                                                                                                                                                                           |                    |
|      | 451 | 73.4 GB 15K RPM ultra3 SCSI disk drive/carrier                                                                     | 112/85, ESCALA PL 250R-VL or ESCALA PL 450R-XS, ESCALA PL 250R-L, ESCALA PL 250R-L+ or ESCALA PL 450R-VL+, ESCALA PL 250T/R+ or ESCALA PL 450T/R-L+, 9405-520, 9406-520, ESCALA PL 250T/R, ESCALA PL 450T/R+ or ESCALA PL 850T/R-L+, 9406-550, ESCALA PL 450T/R, ESCALA PL 1650R-L+, 9406-570, ESCALA PL 850R/PL 1650R/R+, 9406-595, 7/20 | 03N6345<br>03N5280 |
|      |     |                                                                                                                    | 112/85, ESCALA PL 250R-VL or ESCALA PL 450R-XS, ESCALA PL 250R-L, ESCALA PL 250R-L+ or ESCALA PL 450R-VL+, ESCALA PL 250T/R+ or ESCALA PL 450T/R-L+, ESCALA PL 250T/R, ESCALA PL 450T/R+ or ESCALA PL 850T/R-L+, ESCALA PL 450T/R, ESCALA PL 1650R-L+, ESCALA PL 850R/PL 1650R/R+                                                         | 03N5280            |
|      | 453 | When replacing a 146.8 GB 10K RPM SCSI disk drive/carrier in an o/p system, go to <a href="#">453</a> .            |                                                                                                                                                                                                                                                                                                                                           |                    |
|      | 453 | 146.8 GB 10K RPM SCSI disk drive/carrier                                                                           | ESCALA PL 250R-VL or ESCALA PL 450R-XS, ESCALA PL 250R-L, ESCALA PL 250R-L+ or ESCALA PL 450R-VL+, ESCALA PL 250T/R, ESCALA PL 450T/R+ or ESCALA PL 850T/R-L+, ESCALA PL 450T/R, ESCALA PL 1650R-L+, ESCALA PL 850R/PL 1650R/R+, 7/20                                                                                                     | 03N6330            |
|      |     |                                                                                                                    | 112/85, ESCALA PL 250R-VL or ESCALA PL 450R-XS, ESCALA PL 250R-L, ESCALA PL 250R-L+ or                                                                                                                                                                                                                                                    | 03N6330            |

## Service provider information

|  |     |                                                                                                                                                                                               |                                                                                                                                                                                                                                                                                   |                                                     |
|--|-----|-----------------------------------------------------------------------------------------------------------------------------------------------------------------------------------------------|-----------------------------------------------------------------------------------------------------------------------------------------------------------------------------------------------------------------------------------------------------------------------------------|-----------------------------------------------------|
|  |     |                                                                                                                                                                                               | ESCALA PL 450R-VL+, ESCALA PL 250T/R+ or ESCALA PL 450T/R-L+, 9405-520, 9406-520, ESCALA PL 250T/R, ESCALA PL 450T/R+ or ESCALA PL 850T/R-L+, 9406-550, ESCALA PL 450T/R, ESCALA PL 1650R-L+, 9406-570, ESCALA PL 850R/PL 1650R/R+, 9406-595, 7/20                                |                                                     |
|  | 56B | 36.4 GB 15K RPM disk drive                                                                                                                                                                    |                                                                                                                                                                                                                                                                                   | 07N6777                                             |
|  | 56D | When replacing a 36.4 GB 15K RPM ultra3 SCSI disk drive/carrier in an o/p system go to <a href="#">56D</a> .                                                                                  |                                                                                                                                                                                                                                                                                   |                                                     |
|  | 56D | 36.4 GB 15K RPM ultra3 SCSI disk drive/carrier                                                                                                                                                | 11D/20, ESCALA PL 250T/R+ or ESCALA PL 450T/R-L+, 9405-520, 9406-520, ESCALA PL 450T/R+ or ESCALA PL 850T/R-L+, 9406-550, ESCALA PL 1650R-L+, 9406-570, ESCALA PL 850R/PL 1650R/R+, 9406-595, 7/20                                                                                | 03N6340<br>03N5275                                  |
|  |     |                                                                                                                                                                                               | 11D/20, ESCALA PL 250R-VL or ESCALA PL 450R-XS, ESCALA PL 250R-L, ESCALA PL 250R-L+ or ESCALA PL 450R-VL+, ESCALA PL 250T/R+ or ESCALA PL 450T/R-L+, ESCALA PL 250T/R, ESCALA PL 450T/R+ or ESCALA PL 850T/R-L+, ESCALA PL 450T/R, ESCALA PL 1650R-L+, ESCALA PL 850R/PL 1650R/R+ | 03N5275                                             |
|  | 57B | 73.4 GB 10K RPM, 68-pin ultra LVD SCSI disk drive<br><br><b>Note:</b> The FRU part numbers are interchangeable. Order the FRU part number that matches the FRU part number you are replacing. |                                                                                                                                                                                                                                                                                   | 09P4882<br>07N3172<br>00P3069<br>80P3153<br>80P3397 |
|  | 57D | When replacing a 73.4 GB 10K RPM, 68-pin ultra LVD SCSI disk drive in an o/p system go to <a href="#">57D</a> .                                                                               |                                                                                                                                                                                                                                                                                   |                                                     |
|  | 57D | 73.4 GB 10K RPM, 80-pin SCSI disk drive/carrier                                                                                                                                               | 112/85, ESCALA PL 250R-VL or ESCALA PL 450R-XS, ESCALA PL 250R-L, ESCALA PL 250R-L+ or ESCALA PL 450R-VL+, ESCALA PL 250T/R, ESCALA PL 450T/R+ or ESCALA PL 850T/R-L+, ESCALA PL 450T/R, ESCALA PL 1650R-L+, ESCALA PL 850R/PL 1650R/R+, 11D/20                                   | 03N5260<br>03N6325                                  |
|  | 58B | 9.1 GB 10K RPM SCSI disk drive/carrier<br><br><b>Note:</b> The FRU part numbers are interchangeable. Order the FRU part number that matches the FRU part number you are replacing.            |                                                                                                                                                                                                                                                                                   | 09P4874<br>09P3921                                  |

## Service provider information

|     |                                                                                                                                                                                         |                                                                                                                          |                                                     |
|-----|-----------------------------------------------------------------------------------------------------------------------------------------------------------------------------------------|--------------------------------------------------------------------------------------------------------------------------|-----------------------------------------------------|
| 58D | 18.2 GB 10K RPM SCSI disk drive/carrier<br><br><b>Note:</b> The FRU part numbers are interchangeable. Order the FRU part number that matches the FRU part number you are replacing.     | 11D/20                                                                                                                   | 00P3829<br>00P3064                                  |
| 59B | When replacing a 736.4 GB 10K RPM SCSI disk drive/carrier in an o/pr system go to <a href="#">59B</a> .                                                                                 |                                                                                                                          |                                                     |
| 59B | 36.4 GB 10K RPM SCSI disk drive/carrier                                                                                                                                                 | ESCALA PL 850R/PL 1650R/R+, 7/20                                                                                         | 00P3831                                             |
|     |                                                                                                                                                                                         | 9405-520, 9406-520, ESCALA PL 250T/R, 9406-550, ESCALA PL 1650R-L+, 9406-570, ESCALA PL 850R/PL 1650R/R+, 9406-595, 7/20 | 00P3068                                             |
| 59B | 36.4 GB 10K RPM SCSI disk drive/carrier<br><br><b>Note:</b> The FRU part numbers are interchangeable. Order the FRU part number that matches the FRU part number you are replacing.     | 11D/20                                                                                                                   | 00P3831<br>00P3068                                  |
| 601 | 9.1 GB LVD 68-pin SCSI disk drive<br>9.1 GB LVD 68-pin drive/carrier (U2)<br>9.1 GB LVD 68-pin drive/carrier (SP)                                                                       |                                                                                                                          | 07N3675<br>03N3873<br>31L8768                       |
| 60B | 18.2 GB LVD 10K RPM, 68-pin SCSI disk drive<br><br><b>Note:</b> The FRU part numbers are interchangeable. Order the FRU part number that matches the FRU part number you are replacing. |                                                                                                                          | 07N4813<br>09P4429<br>07N3174<br>00P3061<br>80P3149 |
| 61B | 36.4 GB 10K RPM, 80-pin SCSI disk drive<br><br><b>Note:</b> The FRU part numbers are interchangeable. Order the FRU part number that matches the FRU part number you are replacing.     |                                                                                                                          | 07N4833<br>09P4443<br>07N3177<br>00P3067<br>80P3152 |
| 61D | 36.4 GB 10K RPM drive/carrier                                                                                                                                                           |                                                                                                                          | 00P1519                                             |
| 61E | 18.2 GB 10K RPM drive/carrier                                                                                                                                                           |                                                                                                                          | 00P1511                                             |
| 621 | 9.1 GB LVD 80-pin drive/carrier (U2)                                                                                                                                                    |                                                                                                                          | 03N3301                                             |

## Service provider information

|     |                                                                                                                                                                                     |  |                                                     |
|-----|-------------------------------------------------------------------------------------------------------------------------------------------------------------------------------------|--|-----------------------------------------------------|
| 623 | 18.2 GB LVD 68-pin SCSI disk drive<br>18.2 GB LVD 68-pin drive/carrier (U2)<br>18.2 GB LVD 68-pin drive/carrier (SP)                                                                |  | 07N3674<br>03N3874<br>31L8770                       |
| 624 | 18.2 GB LVD 80-pin drive/carrier (U2)                                                                                                                                               |  | 03N3302                                             |
| 62D | 9.1 GB 10K RPM, 68-pin SCSI disk drive<br><br><b>Note:</b> The FRU part numbers are interchangeable. Order the FRU part number that matches the FRU part number you are replacing.  |  | 09P4868<br>07N3179<br>80P3148                       |
| 62E | 9.1 GB 10K RPM drive/carrier                                                                                                                                                        |  | 00P1508                                             |
| 638 | 4.5 GB 16-bit ultra SCSI SE disk drive                                                                                                                                              |  | 22L0027                                             |
| 639 | 9.1 GB ultra SCSI disk drive (68-pin)<br>Spacer<br>tray<br>ID cable<br>Screw                                                                                                        |  | 34L2232<br>08L1155<br>06H9389<br>06H7691<br>1147429 |
| 63A | See 62D.                                                                                                                                                                            |  |                                                     |
| 63B | 9.1 GB 10K RPM, 80-pin SCSI disk drive                                                                                                                                              |  | 07N4853                                             |
| 63C |                                                                                                                                                                                     |  | See 60B.                                            |
| 63E | 36.4 GB 10K RPM, 68-pin SCSI disk drive<br><br><b>Note:</b> The FRU part numbers are interchangeable. Order the FRU part number that matches the FRU part number you are replacing. |  | 07N4803<br>09P4439<br>07N3173<br>00P3065<br>80P3151 |
| 63F | See 61B.                                                                                                                                                                            |  |                                                     |
| 640 | 9.1 GB ultra SCSI disk drive (80-pin)<br>tray<br>Screw                                                                                                                              |  | 34L2233<br>44H4644<br>44H4266                       |
| 643 | 18.2 GB ultra LVD SCSI disk drive                                                                                                                                                   |  | 09L3116                                             |
| 644 | 36.2 GB ultra LVD SCSI disk drive                                                                                                                                                   |  | 09L3339                                             |
| 64A | See 62E.                                                                                                                                                                            |  |                                                     |
| 64B | 9.1 GB LVD 80-pin drive/carrier                                                                                                                                                     |  | 00P1517                                             |
| 64C | See 61E.                                                                                                                                                                            |  |                                                     |
| 64D | 18.2 GB LVD 80-pin drive/carrier                                                                                                                                                    |  | 00P1520                                             |
| 64E | 36.4 GB 10K RPM drive/carrier                                                                                                                                                       |  | 00P1514                                             |
| 64F | See 61D.                                                                                                                                                                            |  |                                                     |
| 650 | Unknown disk drive.                                                                                                                                                                 |  |                                                     |



## Service provider information

|     |                                                                                                                                               |                                                                                                                            |                                                     |
|-----|-----------------------------------------------------------------------------------------------------------------------------------------------|----------------------------------------------------------------------------------------------------------------------------|-----------------------------------------------------|
|     |                                                                                                                                               | <b>Note:</b> This FFC indicates that the disk drive could not properly configure. Refer to the disk drive FRU part number. |                                                     |
| 66E | 4.7 GB DVD-RAM drive,<br>black bezel<br>4.7 GB DVD-RAM drive,<br>white bezel                                                                  |                                                                                                                            | 04N5967<br>04N5968                                  |
| 673 | 18.2 GB differential SCSI disk drive                                                                                                          |                                                                                                                            | 59H6925                                             |
| 679 | 4.5 GB SCSI disk drive                                                                                                                        |                                                                                                                            | 83H7105                                             |
| 681 | 9.1 GB ultra-SCSI 16-bit drive                                                                                                                |                                                                                                                            | 59H6926                                             |
| 689 | 4.5 GB 16-bit ultra SCSI SE disk drive<br>4.5 GB 16-bit ultra SCSI SE disk drive assembly                                                     |                                                                                                                            | 83H7105<br>93H9005                                  |
| 690 | 9.1 GB 16-bit ultra SCSI SE disk drive                                                                                                        |                                                                                                                            | 76H2698                                             |
| 700 | 1.1 GB 8-bit SE disk drive assembly                                                                                                           |                                                                                                                            | 74G6995                                             |
| 701 | 1.1 GB 16-bit SE disk drive assembly<br>tray assembly<br>4 position ID cable<br>electronics card assembly                                     |                                                                                                                            | 74G7006<br>06H8631<br>06H7691<br>27H0380            |
| 702 | 1.1 GB 16-bit DE disk drive assembly<br>electronics card assembly                                                                             |                                                                                                                            | 74G7009<br>74G7015                                  |
| 703 | 2.2 GB 8-bit SE disk drive<br>electronics card assembly                                                                                       |                                                                                                                            | 74G6996<br>74G6998                                  |
| 704 | 2.2 GB 16-bit SE disk drive assembly<br>2.2 GB 16-bit SE disk drive unit<br>tray assembly<br>4 position ID cable<br>electronics card assembly |                                                                                                                            | 74G8824<br>74G7007<br>06H8631<br>06H7691<br>27H0380 |
| 705 | 2.2 GB 16-bit DE disk drive assembly<br>electronics card assembly                                                                             |                                                                                                                            | 74G7010<br>74G7015                                  |
| 706 | 4.5 GB 16-bit SE disk drive<br>4.5 GB 16-bit SE disk drive assembly<br>tray assembly<br>4 position ID cable<br>electronics card assembly      |                                                                                                                            | 74G7008<br>74G8825<br>06H8631<br>06H7691<br>27H0380 |
| 707 | 4.5 GB 16-bit DE disk drive assembly<br>electronics card assembly                                                                             |                                                                                                                            | 74G7011<br>74G7015                                  |
| 722 | Unknown disk drive                                                                                                                            |                                                                                                                            |                                                     |
| 741 | 1.08 GB SCSI-2 disk drive (1-inch high)<br>8-bit tray assembly                                                                                |                                                                                                                            | 52G0124<br>06H8631                                  |
| 759 | 1080 MB disk drive                                                                                                                            |                                                                                                                            | 87G8976                                             |
| 772 | 4.5 GB 16-bit SCSI F/W disk drive                                                                                                             |                                                                                                                            | 83H7105                                             |

## Service provider information

|     |                                                                                                                                                                                                                                                                    |  |                                                     |
|-----|--------------------------------------------------------------------------------------------------------------------------------------------------------------------------------------------------------------------------------------------------------------------|--|-----------------------------------------------------|
| 773 | 9.1 GB 16-bit SCSI F/W disk drive                                                                                                                                                                                                                                  |  | 76H2698                                             |
| 774 | 9.1 GB external SCSI DE disk drive                                                                                                                                                                                                                                 |  | 27H1677                                             |
| 784 | 2.1 GB 8-bit SCSI-2 disk drive<br>2.1 GB 16-bit SCSI-2 disk drive                                                                                                                                                                                                  |  | 93H7151<br>93H7152                                  |
| 789 | External 2.6 GB rewritable optical disk drive                                                                                                                                                                                                                      |  | 50G0212                                             |
| 791 | 2.2 GB 16-bit SE disk drive assembly<br>2.2 GB 16-bit SE disk drive unit tray assembly<br>4 position ID cable electronics card assembly                                                                                                                            |  | 74G8824<br>74G7007<br>06H8631<br>06H7691<br>27H0380 |
| 792 | 4.5 GB 16-bit SE disk drive assembly                                                                                                                                                                                                                               |  | 83H7105                                             |
| 793 | 9.1 GB 16-bit SE disk drive assembly                                                                                                                                                                                                                               |  | 76H2698                                             |
| 845 | RAIDiant array SCSI 2.0 GB disk drive<br><br><b>Note:</b> Refer to the 7135 documentation.                                                                                                                                                                         |  |                                                     |
| 846 | RAIDiant array SCSI 1.3 GB disk drive<br><br><b>Note:</b> Refer to the 7135 documentation.                                                                                                                                                                         |  |                                                     |
| 912 | 2.0 GB SCSI-2 DE disk drive differential frame electronics<br><br><b>Attention:</b> Check RETAIN for frame electronics availability. Exchange the complete drive assembly whenever possible. Exchange the logic card only when the data on the disk must be saved. |  | 86F0119<br>86F0125                                  |
| 913 | 1 GB DE disk drive, half-height differential frame electronics                                                                                                                                                                                                     |  | 6374682<br>6374683                                  |
| 917 | 2.0 GB DE F/W disk drive                                                                                                                                                                                                                                           |  | 86F0767                                             |

## Service provider information

|     |                                                                                                                   |                                                                                                                                     |                               |
|-----|-------------------------------------------------------------------------------------------------------------------|-------------------------------------------------------------------------------------------------------------------------------------|-------------------------------|
|     |                                                                                                                   | <b>Note:</b> If the disk drive is in a 7134 drawer, replace with FRU P/N 67G3022.                                                   |                               |
| 918 | 2.0 GB 16-bit SCSI SE F/W disk drive                                                                              |                                                                                                                                     | 86F0766                       |
| 935 | 1.44 MB 3.5-inch white diskette drive<br>1.44 MB 3.5-inch black diskette drive<br>1.44 MB 3.5-inch diskette drive |                                                                                                                                     | 93F2361<br>76H4091<br>07L7814 |
| 947 | 1000 MB, 16-bit disk drive                                                                                        |                                                                                                                                     | 84G3491                       |
|     | 670 MB SCSI disk drive logic card                                                                                 | <b>Note:</b> Exchange the complete drive whenever possible. If extreme data saving measures are necessary, exchange the logic card. | 53F3429<br>6373521            |
| 952 | 355 MB SCSI disk drive logic card                                                                                 | <b>Note:</b> Exchange the complete drive whenever possible. If extreme data saving measures are necessary, exchange the logic card. | 53F3427<br>6373521            |
| 953 | 320 MB SCSI disk drive logic card and Frame assembly                                                              | <b>Note:</b> Exchange the complete drive whenever possible. Exchange the logic card only when the data on the disk must be saved.   | 93X0961<br>93X0901            |
| 954 | 400 MB SCSI disk drive logic card and frame assembly                                                              | <b>Note:</b> Exchange the complete drive whenever possible. Exchange the logic card only when the data on the disk must be saved.   | 00G1948<br>73F8994            |

Service provider information

|  |      |                                                                                                                                                                                                                                                                                                                                                                                                                                                                                                                                                                                                   |                                                                                                                                                                                                       |                    |
|--|------|---------------------------------------------------------------------------------------------------------------------------------------------------------------------------------------------------------------------------------------------------------------------------------------------------------------------------------------------------------------------------------------------------------------------------------------------------------------------------------------------------------------------------------------------------------------------------------------------------|-------------------------------------------------------------------------------------------------------------------------------------------------------------------------------------------------------|--------------------|
|  | 955  | 857 MB SCSI disk drive                                                                                                                                                                                                                                                                                                                                                                                                                                                                                                                                                                            |                                                                                                                                                                                                       | 45G9502            |
|  | 959  | 160MB SCSI disk drive                                                                                                                                                                                                                                                                                                                                                                                                                                                                                                                                                                             |                                                                                                                                                                                                       | 81F8085            |
|  | 960  | 1.37 GB SCSI disk drive assembly<br>logic card                                                                                                                                                                                                                                                                                                                                                                                                                                                                                                                                                    |                                                                                                                                                                                                       | 52G0061<br>31G9756 |
|  | 968  | 1 GB SCSI SE disk drive<br>single-ended frame<br>electronics                                                                                                                                                                                                                                                                                                                                                                                                                                                                                                                                      |                                                                                                                                                                                                       | 55F9902<br>55F9909 |
|  | 981  | 540 MB SCSI-2 single-ended disk drive                                                                                                                                                                                                                                                                                                                                                                                                                                                                                                                                                             |                                                                                                                                                                                                       | 51G8237            |
|  | 984  | 1 GB 8-bit disk drive                                                                                                                                                                                                                                                                                                                                                                                                                                                                                                                                                                             |                                                                                                                                                                                                       | 45G9467            |
|  | 986  | 2.4 GB SCSI disk drive                                                                                                                                                                                                                                                                                                                                                                                                                                                                                                                                                                            |                                                                                                                                                                                                       | 36G0454            |
|  | 989  | 200 MB SCSI disk drive                                                                                                                                                                                                                                                                                                                                                                                                                                                                                                                                                                            |                                                                                                                                                                                                       | 43G1842            |
|  | 990  | 2.0 GB SCSI-2 SE disk drive                                                                                                                                                                                                                                                                                                                                                                                                                                                                                                                                                                       |                                                                                                                                                                                                       | 86F0118            |
|  | 999  | Disk array subsystems<br><br><b>Note:</b> Refer to the 3514 or 7137 documentation                                                                                                                                                                                                                                                                                                                                                                                                                                                                                                                 |                                                                                                                                                                                                       |                    |
|  | C11  | 2.4 GB SCSI disk drive field repair assembly<br><br><b>Note:</b> The field repair assembly includes one disk drive, the electronics planar, and the 5-1/4 inch form factor cage. The remaining good drive is removed from the failed disk drive assembly and installed in the field repair assembly to create a complete dual-disk drive assembly. If saving data is critical, try installing the faulty drive in place of one of the two good drives in the now-complete field repair assembly. If the faulty drive operates satisfactorily, the problem was probably in the electronics planar. |                                                                                                                                                                                                       | 36G4280            |
|  | 2547 | Generic AS400 SCSI JBOD (not OS disk) disk drive                                                                                                                                                                                                                                                                                                                                                                                                                                                                                                                                                  |                                                                                                                                                                                                       |                    |
|  | 2640 | 2.5 inch IDE disk drive                                                                                                                                                                                                                                                                                                                                                                                                                                                                                                                                                                           |                                                                                                                                                                                                       |                    |
|  |      | Disk controller                                                                                                                                                                                                                                                                                                                                                                                                                                                                                                                                                                                   | 112/85, ESCALA PL 250R-VL or ESCALA PL 450R-XS, ESCALA PL 250R-L+ or ESCALA PL 450R-VL+, ESCALA PL 250T/R+ or ESCALA PL 450T/R-L+, ESCALA PL 450T/R+ or ESCALA PL 850T/R-L+, ESCALA PL 1650R-L+, 7/20 | 39J5107            |
|  |      | 73 GB disk drive                                                                                                                                                                                                                                                                                                                                                                                                                                                                                                                                                                                  | ESCALA PL 245T/R, 471/85                                                                                                                                                                              | 80P3153            |
|  |      | SCSI 73.4 GB disk drive, HV-U320                                                                                                                                                                                                                                                                                                                                                                                                                                                                                                                                                                  | 112/85, ESCALA PL 250R-VL or ESCALA PL 450R-XS, ESCALA PL 250R-L+ or ESCALA PL 450R-VL+, ESCALA PL 250T/R+ or ESCALA PL                                                                               | 03N6327            |





## Service provider information

|          |  |                                                               |     |         |
|----------|--|---------------------------------------------------------------|-----|---------|
|          |  | 1 GB IXS memory module<br>2890-001, 2890-002, and<br>2890-003 |     |         |
| 4812-100 |  | Integrated xSeries Server (IXS)                               | All | 39J4598 |

## Keyboard parts

| CCIN     | Failing Function Code | Description                                                                                                                       | Model, expansion unit, or unit type | Part number                   |
|----------|-----------------------|-----------------------------------------------------------------------------------------------------------------------------------|-------------------------------------|-------------------------------|
| 2890-002 |                       | Keyboard, US English                                                                                                              |                                     | 89P9240                       |
|          | 821                   | Standard keyboard adapter problem<br><br><b>Note:</b> If the type/model and FRU information is not listed here, refer to FFC 221. |                                     |                               |
|          | 921                   | 101 key keyboard                                                                                                                  |                                     | 82G3278<br>1392090<br>1394609 |
|          | 922                   | 102 key keyboard problem<br>keyboard, Arabic                                                                                      |                                     | 8131596                       |
|          | 922                   | Keyboard, Arabic (ID 238)                                                                                                         |                                     | 93H8125                       |
|          | 922                   | Keyboard, Belgium-French (ID 120)                                                                                                 |                                     | 93H8127                       |
|          | 922                   | Keyboard, Belgium-Dutch                                                                                                           |                                     | 1391414                       |
|          | 922                   | Keyboard, Belgium-French                                                                                                          |                                     | 1391526                       |
|          | 922                   | Keyboard, Belgium-French (ID 120)                                                                                                 |                                     | 93H8126                       |
|          | 922                   | Keyboard, Brazilian Portuguese                                                                                                    |                                     | 64F7707                       |
|          | 922                   | Keyboard, Brazilian Portuguese (ID 275)                                                                                           |                                     | 93H8124                       |
|          | 922                   | Keyboard, Bulgarian                                                                                                               |                                     | 1399583                       |
|          | 922                   | Keyboard, Bulgarian (ID 442)                                                                                                      |                                     | 93H8128                       |
|          | 922                   | Keyboard, Chinese/US (ID 467)                                                                                                     |                                     | 93H8155                       |
|          | 922                   | Keyboard, Czechoslovakian                                                                                                         |                                     | 1399570                       |
|          | 922                   | Keyboard, Czechoslovakian (ID 243)                                                                                                |                                     | 93H8129                       |
|          | 922                   | Keyboard, Danish                                                                                                                  |                                     | 1391407                       |
|          | 922                   | Keyboard, Danish (ID 159)                                                                                                         |                                     | 93H8130                       |
|          | 922                   | Keyboard, Dutch (ID 143)                                                                                                          |                                     | 93H8131                       |
|          | 922                   | Keyboard, Dutch/Netherlands                                                                                                       |                                     | 1391511                       |

## Service provider information

|     |                                                                          |                    |
|-----|--------------------------------------------------------------------------|--------------------|
| 922 | Keyboard, Finnish/Swedish                                                | 1391411            |
| 922 | Keyboard, French                                                         | 1391402            |
| 922 | Keyboard, French(ID 189)                                                 | 93H8132            |
| 922 | Keyboard, French-Canadian                                                | 82G3279            |
| 922 | Keyboard, French-Canadian (ID 058)<br>Keyboard, French-Canadian (ID 445) | 93H8121<br>93H8122 |
| 922 | Keyboard, German (ID 129)                                                | 93H8133            |
| 922 | Keyboard, German/Austrian                                                | 1391403            |
| 922 | Keyboard, Greek                                                          | 1399046            |
| 922 | Keyboard, Greek (ID 129)                                                 | 93H8134            |
| 922 | Keyboard, Hebrew                                                         | 1391408            |
| 922 | Keyboard, Hebrew (ID 212)                                                | 93H8135            |
| 922 | Keyboard, Hungarian                                                      | 1399581            |
| 922 | Keyboard, Hungarian (ID 208)                                             | 93H8136            |
| 922 | 102 key keyboard problem<br>Keyboard, Icelandic                          | 1391407            |
| 922 | Keyboard, Icelandic (ID 197)                                             | 93H8137            |
| 922 | Keyboard, Italian                                                        | 1393395            |
| 922 | Keyboard, Italian (ID 142)                                               | 93H8138            |
| 922 | Keyboard, Korea (ID 413)                                                 | 93H8156            |
| 922 | Keyboard, Latin American (Spanish)                                       | 82G3292            |
| 922 | Keyboard, Latvia (ID 234)                                                | 93H8152            |
| 922 | Keyboard, Norwegian                                                      | 1391409            |
| 922 | Keyboard, Norwegian (ID 155)                                             | 93H8139            |
| 922 | Keyboard, Portuguese                                                     | 1391410            |
| 922 | Keyboard, Polish                                                         | 1399580            |
| 922 | Keyboard, Polish (ID 214)                                                | 93H8140            |
| 922 | Keyboard, Portuguese (ID 163)                                            | 93H8141            |
| 922 | Keyboard, Romania                                                        | 1399582            |
| 922 | Keyboard, Romania (ID 446)                                               | 93H8142            |
| 922 | Keyboard, Russian                                                        | 1399579            |
| 922 | Keyboard, Russian (ID 443)                                               | 93H8143            |
| 922 | Keyboard, Serbian (ID 118)                                               | 93H8144            |
| 922 | Keyboard, Slovak                                                         | 1399571            |
| 922 | Keyboard, Slovak (ID 245)                                                | 93H8145            |
| 922 | Keyboard, Spanish                                                        | 1391405            |
| 922 | Keyboard, Spanish (ID 171)<br>Keyboard, Spanish (ID 172)                 | 93H8123<br>93H8146 |
| 922 | Keyboard, Sweden/Finland (ID 153)                                        | 93H8147            |
| 922 | Keyboard, Swiss-French                                                   | 1395881            |
| 922 | Keyboard, Swiss French/German (ID 150)                                   | 93H8148            |
| 922 | Keyboard, Swiss-German                                                   | 1395882            |
| 922 | Keyboard, Thailand (ID 191)                                              | 93H8157            |
| 922 | Keyboard, Turkish (ID 179)                                               | 1393286            |
| 922 | Keyboard, Turkish (ID 179)                                               | 93H8149            |
| 922 | Keyboard, Turkish (ID 440)                                               | 8125409            |



Service provider information

|  |     |                                                                                                                                                           |                                                                                                                                                                                                                                                                                                                                                                                       |                                                     |
|--|-----|-----------------------------------------------------------------------------------------------------------------------------------------------------------|---------------------------------------------------------------------------------------------------------------------------------------------------------------------------------------------------------------------------------------------------------------------------------------------------------------------------------------------------------------------------------------|-----------------------------------------------------|
|  | 922 | Keyboard, Turkish (ID 440)                                                                                                                                |                                                                                                                                                                                                                                                                                                                                                                                       | 93H8150                                             |
|  | 922 | Keyboard, U.K. English                                                                                                                                    |                                                                                                                                                                                                                                                                                                                                                                                       | 1391406                                             |
|  | 922 | Keyboard, Turkish (ID 166)                                                                                                                                |                                                                                                                                                                                                                                                                                                                                                                                       | 93H8151                                             |
|  | 922 | Keyboard, US English ISO9995 (ID 103P)                                                                                                                    |                                                                                                                                                                                                                                                                                                                                                                                       | 93H8153                                             |
|  | 922 | Keyboard, U.S. OEM                                                                                                                                        |                                                                                                                                                                                                                                                                                                                                                                                       | 06H3048                                             |
|  | 922 | Keyboard, 106 Japan (ID 194)                                                                                                                              |                                                                                                                                                                                                                                                                                                                                                                                       | 93H8154                                             |
|  | 923 | 106 keys International keyboard problem<br>keyboard, Chinese<br>keyboard, Japanese-Kanji<br>Japanese, Enhanced<br>keyboard, Korean<br>keyboard, Taiwanese |                                                                                                                                                                                                                                                                                                                                                                                       | 1392090<br>79F0167<br>66G0507<br>06H5286<br>02G7353 |
|  | 930 | Lighted program function keyboard (LPGK), 6094 model 20 cable, serial attachment, power                                                                   |                                                                                                                                                                                                                                                                                                                                                                                       | 39F8226<br>39F8302                                  |
|  | B31 | Unknown keyboard type                                                                                                                                     |                                                                                                                                                                                                                                                                                                                                                                                       |                                                     |
|  |     | Keyboard, English                                                                                                                                         | ESCALA PL 245T/R, ESCALA PL 250R-VL or ESCALA PL 450R-XS, ESCALA PL 250R-L, ESCALA PL 250R-L+ or ESCALA PL 450R-VL+, ESCALA PL 250T/R+ or ESCALA PL 450T/R-L+, 9405-520, 9406-520, ESCALA PL 250T/R, ESCALA PL 450T/R+ or ESCALA PL 850T/R-L+, 9406-550, ESCALA PL 450T/R, ESCALA PL 1650R-L+, 9406-570, ESCALA PL 850R/PL 1650R/R+, 9406-595, 7/20                                   | 10N6956                                             |
|  |     | Keyboard, French (id 189)                                                                                                                                 | ESCALA PL 245T/R, ESCALA PL 250R-VL or ESCALA PL 450R-XS, ESCALA PL 250R-L, ESCALA PL 250R-L+ or ESCALA PL 450R-VL+, ESCALA PL 250T/R+ or ESCALA PL 450T/R-L+, 9405-520, 9406-520, ESCALA PL 250T/R, ESCALA PL 450T/R+ or ESCALA PL 850T/R-L+, 9406-550, ESCALA PL 1650R-L+, 9406-570, ESCALA PL 850R/PL 1650R/R+, ESCALA PL 3250R, ESCALA PL 6450R, 9406-595, 7/20                   | 10N6957                                             |
|  |     | Keyboard, French (id 142)                                                                                                                                 | ESCALA PL 245T/R, ESCALA PL 250R-VL or ESCALA PL 450R-XS, ESCALA PL 250R-L, ESCALA PL 250R-L+ or ESCALA PL 450R-VL+, ESCALA PL 250T/R+ or ESCALA PL 450T/R-L+, 9405-520, 9406-520, ESCALA PL 250T/R, ESCALA PL 450T/R+ or ESCALA PL 850T/R-L+, 9406-550, ESCALA PL 450T/R, ESCALA PL 1650R-L+, 9406-570, ESCALA PL 850R/PL 1650R/R+, ESCALA PL 3250R, ESCALA PL 6450R, 9406-595, 7/20 | 10N6958                                             |
|  |     | Keyboard, German                                                                                                                                          | ESCALA PL 245T/R, ESCALA PL 250R-VL or ESCALA PL 450R-XS, ESCALA PL 250R-L, ESCALA PL 250R-L+ or ESCALA PL 450R-VL+, ESCALA PL 250T/R+ or ESCALA                                                                                                                                                                                                                                      | 10N6959                                             |

Service provider information

|  |  |                                         |                                                                                                                                                                                                                                                                                                                                                                                       |         |
|--|--|-----------------------------------------|---------------------------------------------------------------------------------------------------------------------------------------------------------------------------------------------------------------------------------------------------------------------------------------------------------------------------------------------------------------------------------------|---------|
|  |  |                                         | PL 450T/R-L+, 9405-520, 9406-520, ESCALA PL 250T/R, ESCALA PL 450T/R+ or ESCALA PL 850T/R-L+, 9406-550, ESCALA PL 450T/R, ESCALA PL 1650R-L+, 9406-570, ESCALA PL 850R/PL 1650R/R+, ESCALA PL 3250R, ESCALA PL 6450R, 9406-595, 7/20                                                                                                                                                  |         |
|  |  | Keyboard, UK English (id 166)           | ESCALA PL 245T/R, ESCALA PL 250R-VL or ESCALA PL 450R-XS, ESCALA PL 250R-L, ESCALA PL 250R-L+ or ESCALA PL 450R-VL+, ESCALA PL 250T/R+ or ESCALA PL 450T/R-L+, 9405-520, 9406-520, ESCALA PL 250T/R, ESCALA PL 450T/R+ or ESCALA PL 850T/R-L+, 9406-550, ESCALA PL 450T/R, ESCALA PL 1650R-L+, 9406-570, ESCALA PL 850R/PL 1650R/R+, ESCALA PL 3250R, ESCALA PL 6450R, 9406-595, 7/20 | 10N6960 |
|  |  | Keyboard, Spanish (id 172)              | ESCALA PL 245T/R, ESCALA PL 250R-VL or ESCALA PL 450R-XS, ESCALA PL 250R-L, ESCALA PL 250R-L+ or ESCALA PL 450R-VL+, ESCALA PL 250T/R+ or ESCALA PL 450T/R-L+, 9405-520, 9406-520, ESCALA PL 250T/R, ESCALA PL 450T/R+ or ESCALA PL 850T/R-L+, 9406-550, ESCALA PL 450T/R, ESCALA PL 1650R-L+, 9406-570, ESCALA PL 850R/PL 1650R/R+, ESCALA PL 3250R, ESCALA PL 6450R, 9406-595, 7/20 | 10N6961 |
|  |  | Keyboard, Japanese (id 184)             | ESCALA PL 245T/R, ESCALA PL 250R-VL or ESCALA PL 450R-XS, ESCALA PL 250R-L, ESCALA PL 250R-L+ or ESCALA PL 450R-VL+, ESCALA PL 250T/R+ or ESCALA PL 450T/R-L+, 9405-520, 9406-520, ESCALA PL 250T/R, ESCALA PL 450T/R+ or ESCALA PL 850T/R-L+, 9406-550, ESCALA PL 450T/R, ESCALA PL 1650R-L+, 9406-570, ESCALA PL 850R/PL 1650R/R+, ESCALA PL 3250R, ESCALA PL 6450R, 9406-595, 7/20 | 10N6962 |
|  |  | Keyboard, Brazilian Portuguese (id 275) | ESCALA PL 245T/R, ESCALA PL 250R-VL or ESCALA PL 450R-XS, ESCALA PL 250R-L, ESCALA PL 250R-L+ or ESCALA PL 450R-VL+, ESCALA PL 250T/R+ or ESCALA PL 450T/R-L+, 9405-520, 9406-520, ESCALA PL 250T/R, ESCALA PL 450T/R+ or ESCALA PL 850T/R-L+, 9406-550, ESCALA PL 450T/R, ESCALA PL 1650R-L+, 9406-570, ESCALA PL 850R/PL 1650R/R+, ESCALA PL 3250R, ESCALA PL 6450R, 9406-595, 7/20 | 10N6963 |
|  |  | Keyboard, Canadian French (id 58)       | ESCALA PL 245T/R, ESCALA PL 250R-VL or ESCALA PL 450R-XS, ESCALA PL 250R-L, ESCALA PL 250R-L+ or ESCALA PL 450R-VL+,                                                                                                                                                                                                                                                                  | 10N6968 |

Service provider information

|  |  |                                        |                                                                                                                                                                                                                                                                                                                                                                                       |         |
|--|--|----------------------------------------|---------------------------------------------------------------------------------------------------------------------------------------------------------------------------------------------------------------------------------------------------------------------------------------------------------------------------------------------------------------------------------------|---------|
|  |  |                                        | ESCALA PL 250T/R+ or ESCALA PL 450T/R-L+, 9405-520, 9406-520, ESCALA PL 250T/R, ESCALA PL 450T/R+ or ESCALA PL 850T/R-L+, 9406-550, ESCALA PL 450T/R, ESCALA PL 1650R-L+, 9406-570, ESCALA PL 850R/PL 1650R/R+, ESCALA PL 3250R, ESCALA PL 6450R, 9406-595, 7/20                                                                                                                      |         |
|  |  | Keyboard, Belgium Dutch (id 120)       | ESCALA PL 245T/R, ESCALA PL 250R-VL or ESCALA PL 450R-XS, ESCALA PL 250R-L, ESCALA PL 250R-L+ or ESCALA PL 450R-VL+, ESCALA PL 250T/R+ or ESCALA PL 450T/R-L+, 9405-520, 9406-520, ESCALA PL 250T/R, ESCALA PL 450T/R+ or ESCALA PL 850T/R-L+, 9406-550, ESCALA PL 450T/R, ESCALA PL 1650R-L+, 9406-570, ESCALA PL 850R/PL 1650R/R+, ESCALA PL 3250R, ESCALA PL 6450R, 9406-595, 7/20 | 10N6969 |
|  |  | Keyboard, Swedish Finnish (id 153)     | ESCALA PL 245T/R, ESCALA PL 250R-VL or ESCALA PL 450R-XS, ESCALA PL 250R-L, ESCALA PL 250R-L+ or ESCALA PL 450R-VL+, ESCALA PL 250T/R+ or ESCALA PL 450T/R-L+, 9405-520, 9406-520, ESCALA PL 250T/R, ESCALA PL 450T/R+ or ESCALA PL 850T/R-L+, 9406-550, ESCALA PL 450T/R, ESCALA PL 1650R-L+, 9406-570, ESCALA PL 850R/PL 1650R/R+, ESCALA PL 3250R, ESCALA PL 6450R, 9406-595, 7/20 | 10N6970 |
|  |  | Keyboard, Danish (id 159)              | ESCALA PL 245T/R, ESCALA PL 250R-VL or ESCALA PL 450R-XS, ESCALA PL 250R-L, ESCALA PL 250R-L+ or ESCALA PL 450R-VL+, ESCALA PL 250T/R+ or ESCALA PL 450T/R-L+, 9405-520, 9406-520, ESCALA PL 250T/R, ESCALA PL 450T/R+ or ESCALA PL 850T/R-L+, 9406-550, ESCALA PL 450T/R, ESCALA PL 1650R-L+, 9406-570, ESCALA PL 850R/PL 1650R/R+, ESCALA PL 3250R, ESCALA PL 6450R, 9406-595, 7/20 | 10N6971 |
|  |  | Keyboard, Bulgarian (id 442)           | ESCALA PL 245T/R, ESCALA PL 250R-VL or ESCALA PL 450R-XS, ESCALA PL 250R-L, ESCALA PL 250R-L+ or ESCALA PL 450R-VL+, ESCALA PL 250T/R+ or ESCALA PL 450T/R-L+, 9405-520, 9406-520, ESCALA PL 250T/R, ESCALA PL 450T/R+ or ESCALA PL 850T/R-L+, 9406-550, ESCALA PL 450T/R, ESCALA PL 1650R-L+, 9406-570, ESCALA PL 850R/PL 1650R/R+, ESCALA PL 3250R, ESCALA PL 6450R, 9406-595, 7/20 | 10N6972 |
|  |  | Keyboard, Swiss French German (id 150) | ESCALA PL 245T/R, ESCALA PL 250R-VL or ESCALA PL 450R-XS, ESCALA PL 250R-L, ESCALA PL                                                                                                                                                                                                                                                                                                 | 10N6973 |

Service provider information

|  |  |                               |                                                                                                                                                                                                                                                                                                                                                                                       |         |
|--|--|-------------------------------|---------------------------------------------------------------------------------------------------------------------------------------------------------------------------------------------------------------------------------------------------------------------------------------------------------------------------------------------------------------------------------------|---------|
|  |  |                               | 250R-L+ or ESCALA PL 450R-VL+, ESCALA PL 250T/R+ or ESCALA PL 450T/R-L+, 9405-520, 9406-520, ESCALA PL 250T/R, ESCALA PL 450T/R+ or ESCALA PL 850T/R-L+, 9406-550, ESCALA PL 450T/R, ESCALA PL 1650R-L+, 9406-570, ESCALA PL 850R/PL 1650R/R+, ESCALA PL 3250R, ESCALA PL 6450R, 9406-595, 7/20                                                                                       |         |
|  |  | Keyboard, Norwegian (id 155)  | ESCALA PL 245T/R, ESCALA PL 250R-VL or ESCALA PL 450R-XS, ESCALA PL 250R-L, ESCALA PL 250R-L+ or ESCALA PL 450R-VL+, ESCALA PL 250T/R+ or ESCALA PL 450T/R-L+, 9405-520, 9406-520, ESCALA PL 250T/R, ESCALA PL 450T/R+ or ESCALA PL 850T/R-L+, 9406-550, ESCALA PL 450T/R, ESCALA PL 1650R-L+, 9406-570, ESCALA PL 850R/PL 1650R/R+, ESCALA PL 3250R, ESCALA PL 6450R, 9406-595, 7/20 | 10N6974 |
|  |  | Keyboard, Portuguese (id 163) | ESCALA PL 245T/R, ESCALA PL 250R-VL or ESCALA PL 450R-XS, ESCALA PL 250R-L, ESCALA PL 250R-L+ or ESCALA PL 450R-VL+, ESCALA PL 250T/R+ or ESCALA PL 450T/R-L+, 9405-520, 9406-520, ESCALA PL 250T/R, ESCALA PL 450T/R+ or ESCALA PL 850T/R-L+, 9406-550, ESCALA PL 450T/R, ESCALA PL 1650R-L+, 9406-570, ESCALA PL 850R/PL 1650R/R+, ESCALA PL 3250R, ESCALA PL 6450R, 9406-595, 7/20 | 10N6976 |
|  |  | Keyboard, Greek (id 319)      | ESCALA PL 245T/R, ESCALA PL 250R-VL or ESCALA PL 450R-XS, ESCALA PL 250R-L, ESCALA PL 250R-L+ or ESCALA PL 450R-VL+, ESCALA PL 250T/R+ or ESCALA PL 450T/R-L+, 9405-520, 9406-520, ESCALA PL 250T/R, ESCALA PL 450T/R+ or ESCALA PL 850T/R-L+, 9406-550, ESCALA PL 450T/R, ESCALA PL 1650R-L+, 9406-570, ESCALA PL 850R/PL 1650R/R+, ESCALA PL 3250R, 9406-595, 7/20                  | 10N6977 |
|  |  | Keyboard, Hebrew (id 312)     | ESCALA PL 245T/R, ESCALA PL 250R-VL or ESCALA PL 450R-XS, ESCALA PL 250R-L, ESCALA PL 250R-L+ or ESCALA PL 450R-VL+, ESCALA PL 250T/R+ or ESCALA PL 450T/R-L+, 9405-520, 9406-520, ESCALA PL 250T/R, ESCALA PL 450T/R+ or ESCALA PL 850T/R-L+, 9406-550, ESCALA PL 450T/R, ESCALA PL 1650R-L+, 9406-570, ESCALA PL 850R/PL 1650R/R+, ESCALA PL 3250R, ESCALA PL 6450R, 9406-595, 7/20 | 10N6978 |
|  |  | Keyboard, Hungarian (id 208)  | ESCALA PL 245T/R, ESCALA PL 250R-VL or ESCALA PL 450R-XS, ESCALA PL 250R-L, ESCALA PL                                                                                                                                                                                                                                                                                                 | 10N6964 |

Service provider information

|  |  |                                    |                                                                                                                                                                                                                                                                                                                                                                                       |         |
|--|--|------------------------------------|---------------------------------------------------------------------------------------------------------------------------------------------------------------------------------------------------------------------------------------------------------------------------------------------------------------------------------------------------------------------------------------|---------|
|  |  |                                    | 250R-L+ or ESCALA PL 450R-VL+, ESCALA PL 250T/R+ or ESCALA PL 450T/R-L+, 9405-520, 9406-520, ESCALA PL 250T/R, ESCALA PL 450T/R+ or ESCALA PL 850T/R-L+, 9406-550, ESCALA PL 450T/R, ESCALA PL 1650R-L+, 9406-570, ESCALA PL 850R/PL 1650R/R+, ESCALA PL 3250R, ESCALA PL 6450R, 9406-595, 7/20                                                                                       |         |
|  |  | Keyboard, Polish (id 214)          | ESCALA PL 245T/R, ESCALA PL 250R-VL or ESCALA PL 450R-XS, ESCALA PL 250R-L, ESCALA PL 250R-L+ or ESCALA PL 450R-VL+, ESCALA PL 250T/R+ or ESCALA PL 450T/R-L+, 9405-520, 9406-520, ESCALA PL 250T/R, ESCALA PL 450T/R+ or ESCALA PL 850T/R-L+, 9406-550, ESCALA PL 450T/R, ESCALA PL 1650R-L+, 9406-570, ESCALA PL 850R/PL 1650R/R+, ESCALA PL 3250R, ESCALA PL 6450R, 9406-595, 7/20 | 10N6979 |
|  |  | Keyboard, Slovakian (id 245)       | ESCALA PL 245T/R, ESCALA PL 250R-VL or ESCALA PL 450R-XS, ESCALA PL 250R-L, ESCALA PL 250R-L+ or ESCALA PL 450R-VL+, ESCALA PL 250T/R+ or ESCALA PL 450T/R-L+, 9405-520, 9406-520, ESCALA PL 250T/R, ESCALA PL 450T/R+ or ESCALA PL 850T/R-L+, 9406-550, ESCALA PL 450T/R, ESCALA PL 1650R-L+, 9406-570, ESCALA PL 850R/PL 1650R/R+, ESCALA PL 3250R, ESCALA PL 6450R, 9406-595, 7/20 | 10N6980 |
|  |  | Keyboard, Czechoslovakian (id 245) | ESCALA PL 245T/R, ESCALA PL 250R-VL or ESCALA PL 450R-XS, ESCALA PL 250R-L, ESCALA PL 250R-L+ or ESCALA PL 450R-VL+, ESCALA PL 250T/R+ or ESCALA PL 450T/R-L+, 9405-520, 9406-520, ESCALA PL 250T/R, ESCALA PL 450T/R+ or ESCALA PL 850T/R-L+, 9406-550, ESCALA PL 450T/R, ESCALA PL 1650R-L+, 9406-570, ESCALA PL 850R/PL 1650R/R+, ESCALA PL 3250R, ESCALA PL 6450R, 9406-595, 7/20 | 10N6981 |
|  |  | Keyboard, Turkish (id 179)         | ESCALA PL 245T/R, ESCALA PL 250R-VL or ESCALA PL 450R-XS, ESCALA PL 250R-L, ESCALA PL 250R-L+ or ESCALA PL 450R-VL+, ESCALA PL 250T/R+ or ESCALA PL 450T/R-L+, 9405-520, 9406-520, ESCALA PL 250T/R, ESCALA PL 450T/R+ or ESCALA PL 850T/R-L+, 9406-550, ESCALA PL 450T/R, ESCALA PL 1650R-L+, 9406-570, ESCALA PL 850R/PL 1650R/R+, ESCALA PL 3250R, ESCALA PL 6450R, 9406-595, 7/20 | 10N6982 |
|  |  | Keyboard, Spanish (id 171)         | ESCALA PL 245T/R, ESCALA PL 250R-VL or ESCALA PL 450R-XS,                                                                                                                                                                                                                                                                                                                             | 10N6983 |

Service provider information

|  |  |                                    |                                                                                                                                                                                                                                                                                                                                                                                       |         |
|--|--|------------------------------------|---------------------------------------------------------------------------------------------------------------------------------------------------------------------------------------------------------------------------------------------------------------------------------------------------------------------------------------------------------------------------------------|---------|
|  |  |                                    | ESCALA PL 250R-L, ESCALA PL 250R-L+ or ESCALA PL 450R-VL+, ESCALA PL 250T/R+ or ESCALA PL 450T/R-L+, 9405-520, 9406-520, ESCALA PL 250T/R, ESCALA PL 450T/R+ or ESCALA PL 850T/R-L+, 9406-550, ESCALA PL 450T/R, ESCALA PL 1650R-L+, 9406-570, ESCALA PL 850R/PL 1650R/R+, ESCALA PL 3250R, ESCALA PL 6450R, 9406-595, 7/20                                                           |         |
|  |  | Keyboard, Arabic (id 238)          | ESCALA PL 245T/R, ESCALA PL 250R-VL or ESCALA PL 450R-XS, ESCALA PL 250R-L, ESCALA PL 250R-L+ or ESCALA PL 450R-VL+, ESCALA PL 250T/R+ or ESCALA PL 450T/R-L+, 9405-520, 9406-520, ESCALA PL 250T/R, ESCALA PL 450T/R+ or ESCALA PL 850T/R-L+, 9406-550, ESCALA PL 450T/R, ESCALA PL 1650R-L+, 9406-570, ESCALA PL 850R/PL 1650R/R+, ESCALA PL 3250R, ESCALA PL 6450R, 9406-595, 7/20 | 10N6984 |
|  |  | Keyboard, Korean (id 413)          | ESCALA PL 245T/R, ESCALA PL 250R-VL or ESCALA PL 450R-XS, ESCALA PL 250R-L, ESCALA PL 250R-L+ or ESCALA PL 450R-VL+, ESCALA PL 250T/R+ or ESCALA PL 450T/R-L+, 9405-520, 9406-520, ESCALA PL 250T/R, ESCALA PL 450T/R+ or ESCALA PL 850T/R-L+, 9406-550, ESCALA PL 450T/R, ESCALA PL 1650R-L+, 9406-570, ESCALA PL 850R/PL 1650R/R+, ESCALA PL 3250R, ESCALA PL 6450R, 9406-595, 7/20 | 10N6965 |
|  |  | Keyboard, Chinese (id 467)         | ESCALA PL 245T/R, ESCALA PL 250R-VL or ESCALA PL 450R-XS, ESCALA PL 250R-L, ESCALA PL 250R-L+ or ESCALA PL 450R-VL+, ESCALA PL 250T/R+ or ESCALA PL 450T/R-L+, 9405-520, 9406-520, ESCALA PL 250T/R, ESCALA PL 450T/R+ or ESCALA PL 850T/R-L+, 9406-550, ESCALA PL 450T/R, ESCALA PL 1650R-L+, 9406-570, ESCALA PL 850R/PL 1650R/R+, ESCALA PL 3250R, ESCALA PL 6450R, 9406-595, 7/20 | 10N6966 |
|  |  | Keyboard, French Canadian (id 445) | ESCALA PL 245T/R, ESCALA PL 250R-VL or ESCALA PL 450R-XS, ESCALA PL 250R-L, ESCALA PL 250R-L+ or ESCALA PL 450R-VL+, ESCALA PL 250T/R+ or ESCALA PL 450T/R-L+, 9405-520, 9406-520, ESCALA PL 250T/R, ESCALA PL 450T/R+ or ESCALA PL 850T/R-L+, 9406-550, ESCALA PL 450T/R, ESCALA PL 1650R-L+, 9406-570, ESCALA PL 850R/PL 1650R/R+, ESCALA PL 3250R, ESCALA PL 6450R, 9406-595, 7/20 | 10N6967 |
|  |  | Keyboard, Thailand (id 191)        |                                                                                                                                                                                                                                                                                                                                                                                       | 10N6985 |



| CCIN | Failing Function Code | Description                                        | Model, expansion unit, or unit type                                                        | Part number |
|------|-----------------------|----------------------------------------------------|--------------------------------------------------------------------------------------------|-------------|
| 303E |                       | 2/4 GB DDR1 POD memory card                        | 9406-595                                                                                   | 12R9410     |
| 303F |                       | 4/8 GB DDR1 POD memory card                        | 9406-595                                                                                   | 12R9413     |
|      |                       | 0/8 gb GB DDR2 POD memory card                     | ESCALA PL 6450R, 9406-595                                                                  | 41V1956     |
|      |                       | 0/16 GB DDR2 POD memory card                       | ESCALA PL 6450R, 9406-595                                                                  | 41V1957     |
| 3043 |                       | 512 MB DDR1 memory DIMM                            | 9406-570                                                                                   | 53P1611     |
| 3044 |                       | 1 GB DDR1 memory DIMM                              | 9406-570                                                                                   | 53P1632     |
| 3046 |                       | 2 GB DDR1 memory DIMM                              | 9406-570                                                                                   | 53P1639     |
| 304E |                       | 16 GB DDR1 POD memory card                         | 9406-595                                                                                   | 12R6723     |
| 3093 |                       | 512 MB DDR1 memory DIMM                            | 9406-520                                                                                   | 53P1613     |
| 3094 |                       | 1 GB DDR1 memory DIMM                              | 9406-520                                                                                   | 53P1634     |
| 3096 |                       | 2 GB DDR1 memory DIMM                              | 9406-520                                                                                   | 53P1641     |
| 309B |                       | 256 MB DDR1 memory DIMM                            | ESCALA PL 250R-L, 9405-520, 9406-520, ESCALA PL 250T/R, 9406-550, ESCALA PL 450T/R, 185/75 | 12R9283     |
| 309B |                       | 1 GB DDR memory, (4x256 MB) 208 PIN, 266 MHZ SDRAM | , ,                                                                                        | 12R9240     |
| 309D |                       | 512 MB DDR1 memory DIMM                            | 9406-570, ESCALA PL 850R/PL 1650R/R+, 185/75                                               | 12R9240     |
| 309E |                       | 1 GB DDR1 memory DIMM                              | 9406-570, ESCALA PL 850R/PL 1650R/R+, 185/75                                               | 12R8616     |
| 309F |                       | 1 GB DDR1 memory DIMM                              | 9406-570                                                                                   | 53P3230     |
| 30AA |                       | 2 GB DDR1 memory DIMM                              | 9406-570, ESCALA PL 850R/PL 1650R/R+, 185/75                                               | 12R9259     |
| 30AC |                       | 4 GB DDR1 memory DIMM                              | ESCALA PL 250R-L, 9405-520, 9406-520, ESCALA PL 250T/R, 9406-550, ESCALA PL 450T/R         | 12R9276     |
| 30B3 |                       | 4 GB DDR1 memory DIMM                              | 9406-570, ESCALA PL 850R/PL 1650R/R+, 185/75                                               | 12R9278     |
| 30D2 |                       | 512 MB DDR1 memory DIMM                            | ESCALA PL 250R-L, 9405-520, 9406-520, ESCALA PL 250T/R, 9406-550, ESCALA PL 450T/R         | 12R9238     |
| 30D3 |                       | 1 GB DDR1 memory DIMM                              | ESCALA PL 250R-L, 9405-520, 9406-520, ESCALA PL 250T/R, 9406-550, ESCALA PL 450T/R         | 12R8614     |
| 30D5 |                       | 2 GB DDR1 memory DIMM                              | ESCALA PL 250R-L, 9405-520, 9406-520, ESCALA PL 250T/R, 9406-550, ESCALA PL 450T/R         | 12R9257     |
| 30DC |                       | 4 GB DDR2 memory card                              | ESCALA PL 3250R, ESCALA PL 6450R                                                           | 12R8018     |
| 30DE |                       | 1/2 GB DDR1 POD memory DIMM                        | 9406-570, ESCALA PL 850R/PL 1650R/R+, 185/75                                               | 12R9253     |
| 30DF |                       | 16 GB memory DIMM                                  |                                                                                            | 16R0715     |
| 30F0 |                       | 512 MB DDR2 memory DIMM                            | 9406-570, ESCALA PL 850R/PL 1650R/R+,                                                      | 12R8540     |
| 30F2 |                       | 1 GB DDR2 memory DIMM                              | 9406-570, ESCALA PL 850R/PL 1650R/R+,                                                      | 12R8544     |



## Service provider information

|      |     |                                                        |                                                                                                                                                                                                 |         |
|------|-----|--------------------------------------------------------|-------------------------------------------------------------------------------------------------------------------------------------------------------------------------------------------------|---------|
| 30F3 |     | 2 GB DDR2 memory DIMM                                  | 9406-570, ESCALA PL 850R/PL 1650R/R+, 185/75                                                                                                                                                    | 16R1530 |
| 30F7 |     | 8 GB DDR1 memory DIMM                                  | 9406-570, ESCALA PL 850R/PL 1650R/R+                                                                                                                                                            | 12R9269 |
| 30F9 |     | 32 GB DDR1 memory card                                 | ESCALA PL 3250R, ESCALA PL 6450R, 9406-595                                                                                                                                                      | 41V1849 |
| 30FB |     | 512 MB DDR1 memory DIMM                                | 7/10, 7/20                                                                                                                                                                                      | 12R6971 |
| 30FC |     | 1 GB DDR1 memory DIMM                                  | 7/10, 7/20                                                                                                                                                                                      | 15R6744 |
| 30FD |     | 2 GB DDR1 memory DIMM                                  | 7/10, 7/20                                                                                                                                                                                      | 12R9255 |
| 30FE |     | 4 GB DDR1 memory DIMM                                  | 7/10, 7/20                                                                                                                                                                                      | 12R6977 |
| 310D |     | 256 MB DDR1 memory DIMM                                | 7/10, 7/20                                                                                                                                                                                      | 12R9281 |
| 310E |     | 4 GB DDR1 memory DIMM                                  | 9406-570, ESCALA PL 850R/PL 1650R/R+                                                                                                                                                            | 12R9264 |
| 310F |     | 2-4 GB DDR1 POD memory DIMM                            | 9406-570, ESCALA PL 850R/PL 1650R/R+                                                                                                                                                            | 12R9262 |
| 312A |     | 512 MB DDR2 memory DIMM                                | 112/85, ESCALA PL 250R-VL or ESCALA PL 450R-XS, ESCALA PL 250R-L+ or ESCALA PL 450R-VL+, ESCALA PL 250T/R+ or ESCALA PL 450T/R-L+, ESCALA PL 450T/R+ or ESCALA PL 850T/R-L+, ESCALA PL 1650R-L+ | 12R8251 |
| 312B |     | 1 GB DDR2 memory DIMM                                  | 112/85, ESCALA PL 250R-VL or ESCALA PL 450R-XS, ESCALA PL 250R-L+ or ESCALA PL 450R-VL+, ESCALA PL 250T/R+ or ESCALA PL 450T/R-L+, ESCALA PL 450T/R+ or ESCALA PL 850T/R-L+, ESCALA PL 1650R-L+ | 12R8255 |
| 312E |     | 4 GB DDR2 memory DIMM                                  | 112/85, ESCALA PL 250R-VL or ESCALA PL 450R-XS, ESCALA PL 250R-L+ or ESCALA PL 450R-VL+, ESCALA PL 250T/R+ or ESCALA PL 450T/R-L+, ESCALA PL 450T/R+ or ESCALA PL 850T/R-L+                     | 12R8247 |
| 312F |     | 4 GB DDR2 memory DIMM                                  | 9406-570, ESCALA PL 850R/PL 1650R/R+                                                                                                                                                            | 12R8994 |
| 312D |     | 2 GB DDR2 memory DIMM                                  | 112/85, ESCALA PL 250R-VL or ESCALA PL 450R-XS, ESCALA PL 250R-L+ or ESCALA PL 450R-VL+, ESCALA PL 250T/R+ or ESCALA PL 450T/R-L+, ESCALA PL 450T/R+ or ESCALA PL 850T/R-L+, ESCALA PL 1650R-L+ | 12R8239 |
| 314E |     | 2-4 GB POD memory DIMM                                 | ,                                                                                                                                                                                               | 12R9574 |
|      | 214 | Memory control unit problem (system board, CPU card)   | ESCALA PL 250T/R, ESCALA PL 450T/R, ESCALA PL 850R/PL 1650R/R+                                                                                                                                  |         |
|      | 297 | Texture memory module for the GXT800P graphics adapter |                                                                                                                                                                                                 | 93H6055 |
|      | 298 | Base memory module for the GXT800P graphics adapter    |                                                                                                                                                                                                 | 93H6057 |
|      | 2C5 | 32 MB memory module problem                            |                                                                                                                                                                                                 |         |
|      | 2C6 | Memory module problem                                  | ESCALA PL 250T/R, ESCALA PL 450T/R, ESCALA PL 850R/PL 1650R/R+                                                                                                                                  |         |
|      | 2C7 | Base memory card problem                               |                                                                                                                                                                                                 |         |
|      | 2CC | 1 GB memory module                                     |                                                                                                                                                                                                 | 09P0335 |

## Service provider information

|     |                                                                                                                                                               |                  |                               |
|-----|---------------------------------------------------------------------------------------------------------------------------------------------------------------|------------------|-------------------------------|
| 2CD | 256 MB memory module<br>256 MB memory module                                                                                                                  |                  | 07L9030<br>09P0550            |
| 2CE | 512 MB memory module<br>512 MB memory module                                                                                                                  |                  | 11K9758<br>09P0491            |
| 302 | Memory 256 MB card                                                                                                                                            | ESCALA PL 450T/R |                               |
| 303 | 512 MB memory card                                                                                                                                            | ESCALA PL 450T/R |                               |
| 305 | 2 GB memory card                                                                                                                                              | ESCALA PL 450T/R |                               |
| 30A | 4 GB memory card<br><br><b>Note:</b> 23Lxxxx and 04Nxxxx<br>memory cards cannot be mixed.<br>Replace faulty FRUs with FRUs<br>that have the same part number. |                  | 23L7595<br>04N5011            |
| 30B | 8 GB memory card                                                                                                                                              |                  | 04N5531                       |
| B77 | Coprocessor 1 MB memory<br>module                                                                                                                             |                  | 53F2662                       |
| C45 | 12M VRAM memory module                                                                                                                                        |                  | 65G4889                       |
| C46 | 16M VRAM memory module                                                                                                                                        |                  | 65G4890                       |
| C47 | 16M DRAM memory module                                                                                                                                        |                  | 65G4891                       |
| C94 | ARTIC960 4 MB<br>memory module                                                                                                                                |                  | 68X6356                       |
| D67 | 8 MB, ECC, 50 nsec memory<br>module                                                                                                                           |                  |                               |
| D68 | 16 MB, ECC, 50 nsec memory<br>module                                                                                                                          |                  |                               |
| D69 | 32 MB, ECC, 50 nsec memory<br>module                                                                                                                          |                  |                               |
| D70 | 64 MB, ECC, 50 nsec memory<br>module                                                                                                                          |                  |                               |
| D71 | 8 MB, ECC, 60 nsec memory<br>module                                                                                                                           |                  | 42H2771                       |
| D72 | 16 MB, ECC, 60 nsec memory<br>module                                                                                                                          |                  | 42H2772                       |
| D73 | 32 MB, ECC, 60 nsec memory<br>module                                                                                                                          |                  | 42H2773                       |
| D74 | 64 MB, ECC, 60 nsec memory<br>module                                                                                                                          |                  | 42H2774                       |
|     | 128 MB, ECC, 60 nsec memory<br>module                                                                                                                         |                  | 93H6823                       |
|     | 128 MB, ECC, 60 nsec memory<br>module                                                                                                                         |                  | 93H6822                       |
|     | 64 MB ECC memory module, 128<br>MB ECC memory module, 256 MB<br>ECC memory module                                                                             |                  | 07L9302<br>07L9304<br>07L9306 |
|     | 128 MB, ECC memory<br>module<br>256 MB, ECC memory<br>module                                                                                                  |                  | 19L1809<br>29L3302            |
| D75 | 8 MB, ECC, 70 nsec memory<br>module                                                                                                                           |                  | 65G4615                       |
| D76 | 16 MB, ECC, 70 nsec memory<br>module                                                                                                                          |                  |                               |
| D77 |                                                                                                                                                               |                  |                               |

Service provider information

|  |     |                                                        |                |                    |
|--|-----|--------------------------------------------------------|----------------|--------------------|
|  |     | 32 MB, ECC, 70 nsec memory module                      |                |                    |
|  | D78 | 64 MB, ECC, 70 nsec memory module                      |                | 39H9837            |
|  | D83 | 8 MB, parity, 50 nsec memory module                    |                |                    |
|  | D84 | 16 MB, parity, 50 nsec memory module                   |                |                    |
|  | D85 | 32 MB, parity, 50 nsec memory module                   |                |                    |
|  | D86 | 64 MB, parity, 50 nsec memory module                   |                |                    |
|  | D87 | 8 MB, parity, 60 nsec memory module                    |                |                    |
|  | D88 | 16 MB, parity, 60 nsec memory module                   |                |                    |
|  | D89 | 32 MB, parity, 60 nsec memory module                   |                |                    |
|  | D90 | 64 MB, parity, 60 nsec memory module                   |                |                    |
|  | D91 | 8 MB, parity, 70 nsec memory module                    |                |                    |
|  | D92 | 16 MB, parity, 70 nsec memory module                   |                |                    |
|  | D93 | 32 MB, parity, 70 nsec memory module                   |                | 65G4617            |
|  | D94 | 64 MB, ECC, 70 nsec memory module                      |                | 39H9837            |
|  | E11 | 128 MB, ECC, 50 nsec memory module                     |                |                    |
|  | E12 | 128 MB, ECC, 60 nsec memory module                     |                | 93H6821            |
|  |     | 128 MB, ECC, 60 nsec memory module                     |                | 93H6823            |
|  |     | 128 MB, ECC, 60 nsec memory module                     |                | 93H6822            |
|  |     | 128 MB, ECC, 60 nsec memory module                     |                | 93H4702            |
|  |     | 128 MB, ECC, 60 nsec memory module                     |                | 93H4702            |
|  | E13 | 128 MB, ECC, 70 nsec memory module                     |                |                    |
|  | E14 | 128 MB, parity, 50 nsec memory module                  |                |                    |
|  | E15 | 128 MB, parity, 60 nsec memory module                  |                |                    |
|  | E16 | 128 MB, parity, 70 nsec memory module                  |                |                    |
|  | E17 | Memory 16 MB memory module                             |                | 19H0288            |
|  | E18 | Memory 64 MB memory module                             |                | 35H8751            |
|  | E1A | 4 GB memory card                                       |                | 23L7595<br>04N5011 |
|  |     | 128 MB SSA adapter memory DIMM                         | , ,            | 09L5585            |
|  |     | 8 MB DDR2 memory DIMM, ARTIC960Hx 4-Port Multiprotocol | Adapter memory | 87H3621            |

Service provider information

|      |  |                                                           |                          |         |
|------|--|-----------------------------------------------------------|--------------------------|---------|
|      |  | PCI Adapter                                               |                          |         |
|      |  | 256 MB memory DIMM, PC2700, 333 MHz, DDR SDRAM            | ESCALA PL 245T/R, 471/85 | 41K0024 |
|      |  | 512 MBDDR memory DIMM                                     | ,                        | 52P8746 |
|      |  | 512 MB memory DIMM, PC2700, 333 MHz, DDR SDRAM            | ESCALA PL 245T/R, 471/85 | 41K0022 |
|      |  | 1 GB memory DIMM, 333 MHz, DDR SDRAM                      | ESCALA PL 245T/R, 471/85 | 41K0023 |
|      |  | 2 GB DDR2 memory DIMM, (2X1 GB) 333 MHz                   | , ,                      | 12R8542 |
|      |  | 2 GB memory DIMM, PC2700, 333 MHz, DDR SDRAM              | ESCALA PL 245T/R, 1/85   | 25R8409 |
|      |  | 0-4 GB DDR2 memory DIMM, POD, (4X1 GB) 533MHZ             | ,                        | 41V1955 |
|      |  | 4 GB DDR2 memory DIMM, (2X2 GB)                           |                          | 12R9616 |
|      |  | 4 GB DDR2 memory DIMM, (2X2 GB) 533MHZ                    | , ,                      | 12R8546 |
|      |  | 4/8 GB DDR2 memory DIMM, POD, 533 MHz                     | ,                        | 41V0128 |
|      |  | 8-16 GB DDR2 memory DIMM, (4x4 GB) 533 MHz                | ,                        | 12R9574 |
|      |  | 16 GB DDR2 memory DIMM, (4x4096 MB) 276-pin, 533 MHz      |                          | 16R1577 |
| 314C |  | 32 GB DDR2 memory DIMM, 400 MHz                           | ,                        | 12R8468 |
|      |  | 512 MB DDR memory DIMM, (2x256 MB) 208-pin, 266 MHz SDRAM | ,                        | 12R9281 |
|      |  | 8 GB DDR2 memory DIMM, (2X4 GB) 276PIN , 533 MHZ SDRAM    | ,                        | 12R9616 |
|      |  | 1 GB memory DIMMS (4x256 MB)                              | , , , , , ,              | 12R9283 |

Miscellaneous

| CCIN | Failing Function Code                | Description                                  | Model, expansion unit, or unit type | Part number |
|------|--------------------------------------|----------------------------------------------|-------------------------------------|-------------|
| 271E | 2 Link switch network interface card | 185/75                                       | 41V1050                             |             |
|      | 132                                  | The program that just loaded may be damaged. |                                     | N/A         |
|      | 159                                  |                                              |                                     | 6247455     |

## Service provider information

|  |     |                                                                                                                                                               |                           |                                          |
|--|-----|---------------------------------------------------------------------------------------------------------------------------------------------------------------|---------------------------|------------------------------------------|
|  |     | Tablet puck problem<br>tablet cursor, models 21, 22                                                                                                           |                           |                                          |
|  |     | Tablet cursor, 4-button, 6093<br>models 11, 12                                                                                                                |                           | 74F3131                                  |
|  |     | Tablet cursor, 6-button, 6093<br>models 11, 12                                                                                                                |                           | 74F3132                                  |
|  | 169 | Operator panel logic problem<br><br><b>Note:</b> If the type/model and FRU<br>information is not listed here, refer<br>to FFC 221.                            |                           |                                          |
|  | 188 | Tablet stylus,<br>models 21, 22<br>Tablet stylus, 6093<br>models 11, 12                                                                                       |                           | 6247454<br>74F3133                       |
|  | 201 | Content moved to FFC 190.                                                                                                                                     |                           |                                          |
|  | 203 | Content moved to FFC 152.                                                                                                                                     |                           |                                          |
|  | 240 | Token-ring network problem                                                                                                                                    |                           |                                          |
|  | 241 | Ethernet network problem                                                                                                                                      |                           |                                          |
|  | 683 | 2105 - all models                                                                                                                                             |                           |                                          |
|  | 815 | <br><b>Note:</b> If the type/model and FRU<br>information is not listed here, refer<br>to FFC 221.                                                            | 9076/POWER3 SMP High Node |                                          |
|  | 816 | Operator panel logic problem<br><br><b>Note:</b> If the type/model and FRU<br>information is not listed here, refer<br>to FFC 221.                            |                           |                                          |
|  | 824 | Standard tablet adapter problem<br><br><b>Note:</b> For type/model and FRU<br>information, if not listed here, refer<br>to FFC 221.                           |                           |                                          |
|  | 837 | Remote async node, 16-port<br>EIA-232 enhanced remote async<br>node, 16-port EIA-232 rack<br>mounted node, 16-port EIA-232<br>power supply, remote async node |                           | 88G3842<br>93H6549<br>40H2589<br>80P3869 |
|  | 902 | Vendor display                                                                                                                                                |                           |                                          |
|  | 903 | Vendor async device                                                                                                                                           |                           |                                          |
|  | 904 | Vendor parallel device                                                                                                                                        |                           |                                          |
|  | 905 | Other vendor device                                                                                                                                           |                           |                                          |
|  | 925 | 3-button mouse                                                                                                                                                |                           | 93H9113<br>76H5084                       |

Service provider information

|      |                                                                                                                         |                                                                |                               |
|------|-------------------------------------------------------------------------------------------------------------------------|----------------------------------------------------------------|-------------------------------|
| 926  | Tablet, 5083 model 21<br>Tablet, 6093 model 11                                                                          |                                                                | 6247450<br>74F3130            |
| 927  | Tablet, 5083 model 22<br>Tablet, 6093 model 12<br>Tablet, 6093 model 21                                                 |                                                                | 6247452<br>74F3140<br>93H7714 |
| 950  | Unknown SCSI device is missing.                                                                                         |                                                                |                               |
| 962  | Use device documentation.                                                                                               |                                                                |                               |
| 963  | Use device documentation.                                                                                               |                                                                |                               |
| 980  | Use device documentation.                                                                                               |                                                                |                               |
| 982  | Use device documentation.                                                                                               |                                                                |                               |
| 983  | Use device documentation.                                                                                               |                                                                |                               |
| B08  | Ethernet 10 base twisted-pair transceiver                                                                               |                                                                | 02G7431                       |
| B09  | Ethernet/ISO 8802.3 transceiver (formerly IEEE 802.3)                                                                   |                                                                | 02G7437                       |
| D06  | 64 Port to 128 port converter kit (four to a pack)<br><br><b>Note:</b> Converter part number is 88G3651                 |                                                                | 88G3650                       |
| D50  | Content moved to FFC 190.                                                                                               |                                                                |                               |
| D97  | Operator panel/speaker assembly                                                                                         |                                                                | 93H7439                       |
| E24  | Resistor assembly                                                                                                       |                                                                | 94H0623                       |
| Exx  | (xx represents any character)<br>Refer to the Firmware Checkpoint Three-Digit Error Code section of the service manual. |                                                                |                               |
| Fxx  | (xx represents any character)<br>Refer to the Firmware Checkpoint Three-Digit Error Code section of the service manual. |                                                                |                               |
| 2D00 | SES/SAF-TE LED Problem<br><br><b>Note:</b> If type/model and FRU information is not listed here, refer to FFC 199.      |                                                                |                               |
| 212  | Cache problem<br><br><b>Note:</b> For type/model and FRU information refer to FFC 210.                                  |                                                                |                               |
| 217  | System ROS/EEPROM problem (CPU card, system board)                                                                      | ESCALA PL 250T/R, ESCALA PL 450T/R, ESCALA PL 850R/PL 1650R/R+ |                               |
| 221  | System I/O control logic problem                                                                                        | ESCALA PL 250T/R, ESCALA PL 450T/R, ESCALA PL 850R/PL 1650R/R+ |                               |
| 226  | System status logic problem                                                                                             |                                                                |                               |

## Service provider information

|     |                                                                                                                                                                |                                                                                          |         |
|-----|----------------------------------------------------------------------------------------------------------------------------------------------------------------|------------------------------------------------------------------------------------------|---------|
|     |                                                                                                                                                                | <b>Note:</b> If the type/model and FRU information is not listed here, refer to FFC 221. |         |
| 261 | RS/232 interposer                                                                                                                                              |                                                                                          | 10N7453 |
| 279 | PTC resistor has been tripped<br><br><b>Note:</b> Refer to SCSI-2 Single-Ended adapter PTC Failure Isolation Procedure in <a href="#">SCSI service hints</a> . |                                                                                          |         |
| 292 | Host - PCI bridge problem (I/O planar, CPU card, system board)                                                                                                 | ESCALA PL 250T/R, ESCALA PL 450T/R, ESCALA PL 850R/PL 1650R/R+                           |         |
| 293 | PCI - PCI bridge problem<br><br><b>Note:</b> If the type/model and FRU information is not listed here, refer to FFC 221.                                       |                                                                                          |         |
| 294 | MPIC interrupt controller problem<br><br><b>Note:</b> If the type/model and FRU information is not listed here, refer to FFC 221.                              |                                                                                          |         |
| 295 | PCI - ISA bridge problem<br><br><b>Note:</b> If the type/model and FRU information is not listed here, refer to FFC 221.                                       |                                                                                          |         |
| 296 | PCI device or adapter problem<br>The FRU can only be identified by it's location code reported by diagnostics.                                                 |                                                                                          |         |
| 2D0 | ISA adapter or integrated device                                                                                                                               |                                                                                          |         |
| 2D4 | System/SP interface logic problem<br>(I/O planar, system board)                                                                                                | ESCALA PL 250T/R, ESCALA PL 450T/R, ESCALA PL 850R/PL 1650R/R+                           |         |
| 2D5 | SP Primary I/O bus problem<br>Service processor card<br>(I/O planar, system board)                                                                             | ESCALA PL 250T/R, ESCALA PL 450T/R, ESCALA PL 850R/PL 1650R/R+                           |         |
| 2D7 | System board                                                                                                                                                   | ESCALA PL 250T/R, ESCALA PL 450T/R, ESCALA PL 850R/PL                                    |         |

## Service provider information

|     |                                                                                                           |  |                                                                   |                               |
|-----|-----------------------------------------------------------------------------------------------------------|--|-------------------------------------------------------------------|-------------------------------|
|     |                                                                                                           |  | 1650R/R+                                                          |                               |
| 2E3 | System port controller problem<br>service processor card                                                  |  | ESCALA PL 250T/R, ESCALA PL 450T/R, ESCALA PL 850R/PL<br>1650R/R+ |                               |
| 2E4 | JTAG/COP controller problem<br>service processor card                                                     |  | ESCALA PL 250T/R, ESCALA PL 450T/R, ESCALA PL 850R/PL<br>1650R/R+ |                               |
| 2E6 | PCI Differential ultra SCSI adapter (4-L)                                                                 |  |                                                                   | 40H6595                       |
| 2E7 | Generic PCI SCSI adapter                                                                                  |  |                                                                   |                               |
| 444 | 2-Port multiprotocol PCI adapter (ASIC)                                                                   |  |                                                                   | 41L5235                       |
| 447 | PCI 64-Bit Fibre Channel adapter                                                                          |  |                                                                   | 80P33                         |
| 636 | TRUBOWAYS 622 Mbps PCI MMF ATM adapter                                                                    |  |                                                                   | 97H7782                       |
| 646 | High-speed token-ring PCI adapter                                                                         |  |                                                                   | 03N3554                       |
| 657 | GXT2000P 3D graphics adapter PCI                                                                          |  |                                                                   | 07L7495                       |
| 662 | System board                                                                                              |  | ESCALA PL 250T/R, ESCALA PL 450T/R, ESCALA PL 850R/PL<br>1650R/R+ |                               |
| 663 | ARTIC960RxD PCI adapter (base card)<br>ARTIC960RxF adapter<br>ARTIC960 Quad T1/E1 adapter (daughter card) |  |                                                                   | 87H3734<br>47L8851<br>09J8829 |
| 669 | PCI Gigabit Ethernet adapter                                                                              |  |                                                                   | 41L6396                       |
| 66A | Keyboard/mouse USB PCI attachment card                                                                    |  |                                                                   | 09P2470                       |
| 66C | 10/100/1000 base-T Ethernet PCI adapter                                                                   |  |                                                                   | 00P1690                       |
| 66D | PCI 4-channel ultra3 SCSI RAID adapter (base card only)                                                   |  |                                                                   | 37L6892                       |
| 674 | ESCON channel PCI adapter assembly<br>ARTIC960Rx PCI base adapter                                         |  |                                                                   | 31L7567<br>39H8084            |
| 675 | ARTIC960Hx PCI base adapter                                                                               |  |                                                                   | 87H3427                       |
| 677 | PCI 32-Bit Fibre Channel adapter                                                                          |  |                                                                   | 09P1173                       |
| 67E | When replacing a GXT135P PCI graphics adapter in an o/p system go to <a href="#">67E</a> .                |  |                                                                   |                               |
| 67E | GXT135P PCI graphics adapter                                                                              |  |                                                                   | 03N5853                       |
| 686 | 8-port asynchronous EIA-232/RS-422 adapter                                                                |  |                                                                   | 93H6541                       |
| 687 | 128-port asynchronous controller                                                                          |  |                                                                   | 93H6545                       |
| 693 | Eicon ISDN DIVA PRO 2.0 PCI S/T adapter for PowerPC System                                                |  |                                                                   | 93H5839                       |
| 697 | TURBOWAYS 155 PCI MMF ATM adapter (1 MB)                                                                  |  |                                                                   | 21H3890                       |
| 698 | TURBOWAYS 155 PCI UTP ATM adapter (1 MB)                                                                  |  |                                                                   | 21H7977                       |
| 69B |                                                                                                           |  |                                                                   | 21P4106                       |



## Service provider information

|     |  |                                                                                                                                                                                                                                                                                                                                                                                                                                                                                                                                                                                                                                                                                                                                                                                                                        |                                                                                                                                                                                                   |
|-----|--|------------------------------------------------------------------------------------------------------------------------------------------------------------------------------------------------------------------------------------------------------------------------------------------------------------------------------------------------------------------------------------------------------------------------------------------------------------------------------------------------------------------------------------------------------------------------------------------------------------------------------------------------------------------------------------------------------------------------------------------------------------------------------------------------------------------------|---------------------------------------------------------------------------------------------------------------------------------------------------------------------------------------------------|
|     |  | 64-bit/66 MHz PCI ATM MMF adapter                                                                                                                                                                                                                                                                                                                                                                                                                                                                                                                                                                                                                                                                                                                                                                                      |                                                                                                                                                                                                   |
| 69D |  | 64-bit/66 MHz PCI ATM 155 UTP adapter                                                                                                                                                                                                                                                                                                                                                                                                                                                                                                                                                                                                                                                                                                                                                                                  | 21P4112                                                                                                                                                                                           |
| 6CC |  | 4.5 GB SSA drive (DCHC/DGHC) in a blue-handled carrier, 9.1 GB 1.6-inch SSA drive (DCHC) in a blue-handled carrier, 9.1 GB 1.0-inch SSA drive (DGHC) in a blue-handled carrier                                                                                                                                                                                                                                                                                                                                                                                                                                                                                                                                                                                                                                         | 59H6259<br>21H8734<br>05J6446                                                                                                                                                                     |
| 711 |  | Unknown adapter                                                                                                                                                                                                                                                                                                                                                                                                                                                                                                                                                                                                                                                                                                                                                                                                        |                                                                                                                                                                                                   |
| 713 |  | ARTIC960Hx PCI base adapter                                                                                                                                                                                                                                                                                                                                                                                                                                                                                                                                                                                                                                                                                                                                                                                            | 87H3427                                                                                                                                                                                           |
| 721 |  | Unknown SCSI device                                                                                                                                                                                                                                                                                                                                                                                                                                                                                                                                                                                                                                                                                                                                                                                                    |                                                                                                                                                                                                   |
| 723 |  | Unknown CD-ROM drive                                                                                                                                                                                                                                                                                                                                                                                                                                                                                                                                                                                                                                                                                                                                                                                                   |                                                                                                                                                                                                   |
| 725 |  | Display, 15", northern hemisphere<br>Display, 15", southern hemisphere<br>Display, 17", northern hemisphere<br>Display, 17", southern hemisphere<br>Display, 17", northern hemisphere (white)<br>Display, 17", northern hemisphere (black)<br>Display, 17", southern hemisphere (white)<br>Display, 17", southern hemisphere (black)<br>Display, 19", northern hemisphere (white)<br>Display, 19", northern hemisphere (black)<br>Display, 19", southern hemisphere (white)<br>Display, 19", southern hemisphere (Black)<br>Display, 20", northern hemisphere<br>Display, 20", Southern hemisphere<br>Display, 21", northern hemisphere (white)<br>Display, 21", northern hemisphere (black)<br>Display, 21", southern hemisphere (white)<br>Display, 21", southern hemisphere (black)<br>Unknown display adapter type | 96G213<br>96G2699<br>96G3020<br>96G2150<br>21L4570<br>21L4571<br>61H0215<br>61H0216<br>61H0412<br>61H0223<br>61H0224<br>61H0225<br>96G2701<br>96G3049<br>60H0233<br>60H0234<br>60H0235<br>60H0236 |
| 726 |  | Unknown input device                                                                                                                                                                                                                                                                                                                                                                                                                                                                                                                                                                                                                                                                                                                                                                                                   |                                                                                                                                                                                                   |
| 727 |  | Unknown async device                                                                                                                                                                                                                                                                                                                                                                                                                                                                                                                                                                                                                                                                                                                                                                                                   |                                                                                                                                                                                                   |
| 728 |  | Unknown parallel device                                                                                                                                                                                                                                                                                                                                                                                                                                                                                                                                                                                                                                                                                                                                                                                                |                                                                                                                                                                                                   |
| 730 |  | Unknown diskette drive                                                                                                                                                                                                                                                                                                                                                                                                                                                                                                                                                                                                                                                                                                                                                                                                 |                                                                                                                                                                                                   |
| 746 |  | PCI SCSI SE adapter problem<br>SCSI-2 Fast/Wide PCI adapter                                                                                                                                                                                                                                                                                                                                                                                                                                                                                                                                                                                                                                                                                                                                                            | 73H3562                                                                                                                                                                                           |
| 747 |  | SCSI-2 differential fast/wide PCI                                                                                                                                                                                                                                                                                                                                                                                                                                                                                                                                                                                                                                                                                                                                                                                      | 93H8407                                                                                                                                                                                           |

## Service provider information

|     |  |                                                                                                                                                                                                                                                                                               |                                                                |                               |
|-----|--|-----------------------------------------------------------------------------------------------------------------------------------------------------------------------------------------------------------------------------------------------------------------------------------------------|----------------------------------------------------------------|-------------------------------|
|     |  | adapter                                                                                                                                                                                                                                                                                       |                                                                |                               |
| 74A |  | Integrated SCSI-2 F/W SE problem system board, integrated SCSI                                                                                                                                                                                                                                |                                                                | 93H4808                       |
| 763 |  | SP switch MX adapter wrap plug terminator                                                                                                                                                                                                                                                     |                                                                | 31L7847<br>46H9688<br>77G0818 |
| 764 |  | SP system attachment adapter wrap plug terminator                                                                                                                                                                                                                                             |                                                                | 08L0398<br>46H9688<br>77G0818 |
| 776 |  | PCI token-ring adapter                                                                                                                                                                                                                                                                        |                                                                | 93H6594                       |
| 785 |  | 8-port ISA Async EIA-232/RS-422 adapter                                                                                                                                                                                                                                                       |                                                                | 40H6632                       |
| 786 |  | GXT250P high performance graphics adapter                                                                                                                                                                                                                                                     |                                                                | 93H6264                       |
| 786 |  | GXT255P high performance graphics adapter                                                                                                                                                                                                                                                     |                                                                | 93H6267                       |
| 787 |  | GXT500P graphics adapter                                                                                                                                                                                                                                                                      |                                                                | 94H0028                       |
| 788 |  | Ultimedia Video Capture adapter                                                                                                                                                                                                                                                               |                                                                | 07L9009                       |
| 78D |  | GXT300P 2D graphics adapter                                                                                                                                                                                                                                                                   |                                                                | 03N4169                       |
| 790 |  | Multi-bus integrated Ethernet adapter problem<br><br><b>Note:</b> If the type/model and FRU information is not listed here, refer to FFC 221.                                                                                                                                                 |                                                                |                               |
| 799 |  | 2-port multiprotocol PCI adapter<br>2-port multiprotocol PCI wrap plug                                                                                                                                                                                                                        |                                                                | 93H6086<br>93H3662            |
| 7C0 |  | System board                                                                                                                                                                                                                                                                                  | ESCALA PL 250T/R, ESCALA PL 450T/R, ESCALA PL 850R/PL 1650R/R+ |                               |
| 807 |  | SCSI device enclosure<br><br><b>Note:</b> If the resource description on the screen displays:<br><br><ul style="list-style-type: none"> <li>• ses or SCSI Enclosure Services Device, use FFC 199.</li> <li>• safte or SCSI Accessed Fault-Tolerant Enclosure Device, use FFC 2580.</li> </ul> |                                                                |                               |
| 80c |  | SSA adapter problem refer to the <i>SSA adapters: User's Guide and Maintenance Information</i> .                                                                                                                                                                                              |                                                                |                               |
| 812 |  | Common standard adapter logic problem                                                                                                                                                                                                                                                         |                                                                |                               |

## Service provider information

|     |                                                                                                                                        |                                                                   |         |
|-----|----------------------------------------------------------------------------------------------------------------------------------------|-------------------------------------------------------------------|---------|
|     |                                                                                                                                        | <b>Note:</b> For type/model and FRU information refer to FFC 227. |         |
| 7C0 | CPU/System Interface System board                                                                                                      |                                                                   |         |
| 817 | System board                                                                                                                           | ESCALA PL 250T/R, ESCALA PL 450T/R, ESCALA PL 850R/PL 1650R/R+    |         |
| 823 | Standard mouse adapter problem<br><br><b>Note:</b> If the type/model and FRU information is not listed here, refer to FFC 221.         |                                                                   |         |
| 826 | System port 1 adapter problem<br><br><b>Note:</b> If the type/model and FRU information is not listed here, refer to FFC 221.          |                                                                   |         |
| 827 | Built-in parallel port adapter problem<br><br><b>Note:</b> If the type/model and FRU information is not listed here, refer to FFC 221. |                                                                   |         |
| 828 | Standard diskette adapter problem<br><br><b>Note:</b> If the type/model and FRU information is not listed here, refer to FFC 221.      |                                                                   |         |
| 82C | S15 graphics PCI adapter                                                                                                               |                                                                   | 11H6095 |
| 831 | System port 2 adapter problem<br><br><b>Note:</b> If the type/model and FRU information is not listed here, refer to FFC 221.          |                                                                   |         |
| 836 | 128-port async controller                                                                                                              |                                                                   | 73H3384 |
| 840 | PCI single-ended ultra SCSI adapter                                                                                                    |                                                                   | 93H3809 |

## Service provider information

|     |  |                                                                                                                                                                                                     |                                                                |                    |
|-----|--|-----------------------------------------------------------------------------------------------------------------------------------------------------------------------------------------------------|----------------------------------------------------------------|--------------------|
|     |  | <b>Note:</b> If you receive this FFC but are working with integrated ultra SCSI, see FFC 84A.                                                                                                       |                                                                |                    |
| 844 |  | RAIDiant array SCSI subsystem controller<br><br><b>Note:</b> Refer to the 7135 documentation.                                                                                                       |                                                                |                    |
| 84A |  | I/O board                                                                                                                                                                                           | ESCALA PL 250T/R, ESCALA PL 450T/R, ESCALA PL 850R/PL 1650R/R+ |                    |
| 868 |  | Integrated SCSI I/O controller problem<br><br><b>Note:</b> If the type/model and FRU information is not listed here, refer to FFC 221.                                                              |                                                                |                    |
| 887 |  | Integrated Ethernet adapter problem, system board, Integrated Ethernet adapter                                                                                                                      | ESCALA PL 250T/R, ESCALA PL 450T/R, ESCALA PL 850R/PL 1650R/R+ |                    |
| 891 |  | Vendor SCSI adapter                                                                                                                                                                                 |                                                                |                    |
| 892 |  | Vendor display adapter                                                                                                                                                                              |                                                                |                    |
| 893 |  | Vendor LAN adapter                                                                                                                                                                                  |                                                                |                    |
| 894 |  | Vendor async Communications adapter                                                                                                                                                                 |                                                                |                    |
| 899 |  | Atape                                                                                                                                                                                               |                                                                |                    |
| 901 |  | Vendor SCSI device                                                                                                                                                                                  |                                                                |                    |
| 929 |  | Dials, 6094 model 10 cable, serial attachment, power                                                                                                                                                |                                                                | 39F8227<br>39F8302 |
| 938 |  | Serial HIPPI PCI adapter<br><br><b>Notes:</b><br><br>1. Use the number printed above the bar code to order this part.<br>2. The FRU part number of the wrap plug used with this adapter is 21H3547. |                                                                |                    |
| 946 |  | Standard system port 3 adapter problem (service processor card, primary I/O book, NIO planar, system board)                                                                                         | ESCALA PL 850R/PL 1650R/R+                                     |                    |
| 956 |  | 355/670 MB logic card                                                                                                                                                                               |                                                                | 6373521            |

|  |     |                                                                                                                                                                                                                                                                                                                                                                                                                                                                                                                                                                                                                                                                                                                                                                                                                       |  |         |
|--|-----|-----------------------------------------------------------------------------------------------------------------------------------------------------------------------------------------------------------------------------------------------------------------------------------------------------------------------------------------------------------------------------------------------------------------------------------------------------------------------------------------------------------------------------------------------------------------------------------------------------------------------------------------------------------------------------------------------------------------------------------------------------------------------------------------------------------------------|--|---------|
|  | 966 | MediaStreamer audio/video decoder adapter                                                                                                                                                                                                                                                                                                                                                                                                                                                                                                                                                                                                                                                                                                                                                                             |  | 93H2136 |
|  | 974 | CD-ROM drive (Type A or Type B bezel)                                                                                                                                                                                                                                                                                                                                                                                                                                                                                                                                                                                                                                                                                                                                                                                 |  | 88G3929 |
|  | B10 | System board PTC (thermal fuse)<br><br><b>Note:</b> If a thermal fuse has opened, it should reset within ten minutes after turning the power off. If the thermal fuse does not reset, a faulty device may be drawing excessive power through the fuse.                                                                                                                                                                                                                                                                                                                                                                                                                                                                                                                                                                |  |         |
|  | B3A | Unidentifiable backplane tied to a SCSI RAID adapter                                                                                                                                                                                                                                                                                                                                                                                                                                                                                                                                                                                                                                                                                                                                                                  |  |         |
|  | B71 | 8-Port EIA-232-D multiport, model 2 interface card                                                                                                                                                                                                                                                                                                                                                                                                                                                                                                                                                                                                                                                                                                                                                                    |  | 53F2612 |
|  | B72 | 8-Port EIA-422-A multiport, model 2 interface card                                                                                                                                                                                                                                                                                                                                                                                                                                                                                                                                                                                                                                                                                                                                                                    |  | 53F2615 |
|  | B73 | 6-Port V.35 multiport, model 2 interface card                                                                                                                                                                                                                                                                                                                                                                                                                                                                                                                                                                                                                                                                                                                                                                         |  | 72F0164 |
|  | B74 | 6-Port V.21 multiport, model 2 interface card                                                                                                                                                                                                                                                                                                                                                                                                                                                                                                                                                                                                                                                                                                                                                                         |  | 04G5500 |
|  | B88 | Generic SCSI I/O controller<br><br><b>Notes:</b><br><br>1. If the failing FRU for this FFC is PCI(x), where x is the PCI bus number, 0, 1, ..., refer to FFC 221.<br>2. Use the location code to identify the failing FRU. Determine if the failing FRU is integrated on the system board. If the failing FRU is integrated use FFC 221. If the failing FRU is not integrated replace the FRU identified by its description that is shown with the location code for SCSI and SCSI-2 adapter. Choose the FFC for the appropriate SCSI I/O controller.<br>3. Check the SCSI controller fuse or PTC resistor before exchanging the system board. Refer to <i>SCSI-2 Single-Ended Adapter PTC Failure Isolation Procedure</i> in <a href="#">SCSI service hints</a> .<br>4. Check that the SCSI disable jumper is in the |  |         |

Service provider information

|  |     |                                                                                                                                 |                                                                |         |
|--|-----|---------------------------------------------------------------------------------------------------------------------------------|----------------------------------------------------------------|---------|
|  |     | enabled position.<br>5. Check the FRU number of the installed external terminator: Low density - 51G7736 High density - 51G7737 |                                                                |         |
|  | C33 | GPSS card                                                                                                                       |                                                                | 73H4034 |
|  | C34 | RSS card (without memory sockets)                                                                                               |                                                                | 11H8490 |
|  | C35 | VOO card                                                                                                                        |                                                                | 65G4887 |
|  | C48 | RSS/GPSS crossover card                                                                                                         |                                                                | 65G4893 |
|  | C95 | ARTIC960 4-port selectable interface board                                                                                      |                                                                | 87H3413 |
|  |     | ARTIC960 4-port T1/E1 interface card                                                                                            |                                                                | 87H3428 |
|  |     | ARTIC960Hx DSP interface card                                                                                                   |                                                                | 87H3701 |
|  |     | ARTIC960 quad T1/E1 interface card                                                                                              |                                                                | 09J8829 |
|  |     | ARTIC960 PCI adapter interface board                                                                                            |                                                                | 51H8702 |
|  | C97 | ARTIC960 4-port T1/E1 interface card wrap plug                                                                                  |                                                                | 87H3502 |
|  |     | ARTIC960 4-port selectable interface board wrap plug                                                                            |                                                                | 87H3311 |
|  |     | ESCON wrap plug                                                                                                                 |                                                                | 5605670 |
|  |     | <b>Note:</b> A wrap plug is shipped with each adapter and cable.                                                                |                                                                |         |
|  | D01 | Generic L2 cache problem                                                                                                        | ESCALA PL 250T/R, ESCALA PL 450T/R, ESCALA PL 850R/PL 1650R/R+ |         |
|  | D59 | TP PCI Ethernet adapter                                                                                                         |                                                                | 93H7766 |
|  | D60 | T2 PCI Ethernet adapter                                                                                                         |                                                                | 93H1902 |
|  | D60 | TP PCI Ethernet adapter                                                                                                         |                                                                | 93H7766 |
|  | D66 | RSS card (with memory sockets)                                                                                                  | 7250                                                           | 11H4436 |
|  | D95 | GXT550P graphics adapter                                                                                                        |                                                                | 94H0029 |
|  | D96 | GXT255P high performance PCI graphics adapter                                                                                   |                                                                | 93H6267 |
|  | E10 | Riser card                                                                                                                      |                                                                | 73H4532 |
|  | E10 | Riser card                                                                                                                      |                                                                | 73H3712 |
|  | E10 | Riser card                                                                                                                      |                                                                | 23L8117 |
|  | E10 |                                                                                                                                 | Refer to <a href="#">FFC 227</a>                               |         |
|  | E19 | Power supply sensor failed I/O planar                                                                                           | ESCALA PL 250T/R, ESCALA PL 450T/R, ESCALA PL 850R/PL 1650R/R+ |         |
|  | E26 | Power distribution card                                                                                                         |                                                                | 93H9551 |

## Service provider information

|      |                                                                                                                                                                                                                                                                                                                                                                                                                                                                                                                  |  |                    |
|------|------------------------------------------------------------------------------------------------------------------------------------------------------------------------------------------------------------------------------------------------------------------------------------------------------------------------------------------------------------------------------------------------------------------------------------------------------------------------------------------------------------------|--|--------------------|
| E26  | Power distribution card                                                                                                                                                                                                                                                                                                                                                                                                                                                                                          |  | 08L0388            |
| E29  | 32 MB cache (located on the LVD SCSI RAID adapter) (includes battery)                                                                                                                                                                                                                                                                                                                                                                                                                                            |  | 21H8979            |
| E2A  | 128 MB cache, U.S. (includes battery)<br>128 MB cache, Japan (includes battery)                                                                                                                                                                                                                                                                                                                                                                                                                                  |  | 37L6902<br>19K0561 |
| 2512 | PCI-X DDR quad channel ultra320 SCSI RAID adapter                                                                                                                                                                                                                                                                                                                                                                                                                                                                |  | 97P6130            |
| 2513 | PCI-X DDR quad channel ultra320 SCSI RAID adapter                                                                                                                                                                                                                                                                                                                                                                                                                                                                |  | 39J0273            |
| 2514 | PCI-X DDR dual channel ultra320 SCSI RAID adapter                                                                                                                                                                                                                                                                                                                                                                                                                                                                |  | 39J2012            |
| 2520 | Dual-channel ultra3 SCSI PCI adapter                                                                                                                                                                                                                                                                                                                                                                                                                                                                             |  | 09P2544            |
| 2522 | When replacing a PCI-X dual channel U320 SCSI adapter in an o/p system go to <a href="#">2522</a> .                                                                                                                                                                                                                                                                                                                                                                                                              |  |                    |
| 2522 | PCI-X dual channel U320 SCSI adapter<br><br><b>Note:</b> Use the location code to identify the failing FRU. Determine if the failing FRU is integrated on the system board. If the failing FRU is integrated use FFC 221. If the failing FRU is not integrated replace the FRU identified here.                                                                                                                                                                                                                  |  | 97P2686            |
| 2523 | When replacing a PCI-X dual channel U320 SCSI RAID adapter in an o/p system go to <a href="#">2523</a> .                                                                                                                                                                                                                                                                                                                                                                                                         |  |                    |
| 2523 | 97P3960 PCI-X dual channel U320 SCSI RAID adapter or enablement card.<br><br><b>Notes:</b><br><br>1. Use the location code to identify if the failing FRU is a RAID enablement card plugged into a special slot on the I/O planar or if it is a PCI-X adapter.<br><br>If the failing FRU is a PCI-X adapter, replace the FRU identified here. If the failing FRU is a RAID enablement card use FFC 2525.<br><br>2. If the problem persists after replacing the RAID enablement card, use FFC 2522 to replace the |  |                    |

|      |  |                                                                                                                                                                                                                                                                                                                                                                                                                |                                                             |
|------|--|----------------------------------------------------------------------------------------------------------------------------------------------------------------------------------------------------------------------------------------------------------------------------------------------------------------------------------------------------------------------------------------------------------------|-------------------------------------------------------------|
|      |  | integrated SCSI adapter.                                                                                                                                                                                                                                                                                                                                                                                       |                                                             |
| 2524 |  | <p>Missing options resolution for integrated PCI-X dual channel U320 SCSI adapter.</p> <p><b>Note:</b> Use the location code to identify the failing FRU. Determine if the failing FRU is integrated on the system board. If the failing FRU is integrated use FFC 221. If the failing FRU is not integrated replace the FRU identified below.</p> <p>PCI-X dual channel U320 SCSI adapter (FRU # 97P2686)</p> |                                                             |
| 2525 |  | Missing options resolution for integrated PCI-X dual channel U320 SCSI RAID enablement card.                                                                                                                                                                                                                                                                                                                   | 80P2868                                                     |
| 2527 |  | Quad channel ultra320 SCSI RAID adapter                                                                                                                                                                                                                                                                                                                                                                        | 39J5581                                                     |
| 2528 |  | PCI-X dual channel ultra320 SCSI adapter                                                                                                                                                                                                                                                                                                                                                                       | 42R4860                                                     |
| 2529 |  | When replacing a PCI-X dual channel ultra320 SCSI RAID adapter in an o/p system, go to <a href="#">2529</a> .                                                                                                                                                                                                                                                                                                  |                                                             |
| 2529 |  | <p>PCI-X dual channel ultra320 SCSI RAID adapter (MLx)</p> <p>PCI-X dual channel ultra320 SCSI RAID adapter (MLx)</p>                                                                                                                                                                                                                                                                                          | <p>39J5652</p> <p>39J1308</p>                               |
| 252B |  | <p>PCI-X DDR dual channel ultra320 SCSI adapter (2 way)</p> <p>PCI-X DDR dual channel ultra320 SCSI adapter (4 way)</p>                                                                                                                                                                                                                                                                                        | <p>39M3417</p> <p>39M3418</p> <p>39M3419</p> <p>39M3420</p> |
| 252D |  | PCI-X DDR dual channel ultra320 SCSI adapter                                                                                                                                                                                                                                                                                                                                                                   | 42R4860                                                     |
| 2530 |  | When replacing a 10/100 Mbps Ethernet PCI adapter II in an o/p system go to <a href="#">2530</a> .                                                                                                                                                                                                                                                                                                             |                                                             |
| 2530 |  | 10/100 Mbps Ethernet PCI adapter II                                                                                                                                                                                                                                                                                                                                                                            | 09P3196                                                     |
| 2531 |  | When replacing a 10 Gigabit-LR Ethernet PCI-X adapter in an o/p system go to <a href="#">2531</a> .                                                                                                                                                                                                                                                                                                            |                                                             |
| 2531 |  | 10 Gigabit-LR Ethernet PCI-X adapter                                                                                                                                                                                                                                                                                                                                                                           | 03N6971                                                     |
| 2532 |  | When replacing a 10 Gigabit-SR Ethernet PCI-X adapter in an o/p                                                                                                                                                                                                                                                                                                                                                |                                                             |







## Service provider information

|      |                                                                                                                                                                            |                                                                                                                                                                                                       |                               |
|------|----------------------------------------------------------------------------------------------------------------------------------------------------------------------------|-------------------------------------------------------------------------------------------------------------------------------------------------------------------------------------------------------|-------------------------------|
|      | PCI 64-Bit 4 GB fibre channel adapter (Low Profile 1-Port)<br>PCI 64-Bit 4 GB fibre channel adapter (2-Port)<br>PCI 64-Bit 4 GB fibre channel adapter (Low Profile 2-Port) |                                                                                                                                                                                                       | 03N5012<br>03N5029<br>03N5027 |
| 2621 | PCI-X Dual-port 4x HCA                                                                                                                                                     |                                                                                                                                                                                                       | 26K7434                       |
| 2631 | Integrated IDE controller                                                                                                                                                  |                                                                                                                                                                                                       |                               |
| 2D02 | Generic USB reference to controller/adapter                                                                                                                                |                                                                                                                                                                                                       |                               |
|      | Divider                                                                                                                                                                    | ESCALA PL 250R-VL or ESCALA PL 450R-XS, ESCALA PL 450T/R+ or ESCALA PL 850T/R-L+, 9406-550, ESCALA PL 450T/R                                                                                          | 97P5894                       |
|      | Light pipe                                                                                                                                                                 | ESCALA PL 250R-VL or ESCALA PL 450R-XS, ESCALA PL 450T/R+ or ESCALA PL 850T/R-L+, 9406-550, ESCALA PL 450T/R                                                                                          | 97P4367                       |
|      | Chassis                                                                                                                                                                    | ESCALA PL 250R-VL or ESCALA PL 450R-XS, ESCALA PL 450T/R+ or ESCALA PL 850T/R-L+, 9406-550, ESCALA PL 450T/R, 7/20                                                                                    | 97P4363                       |
|      | DVD ROM                                                                                                                                                                    | ESCALA PL 250R-VL or ESCALA PL 450R-XS                                                                                                                                                                | 03N4536                       |
|      | PCI adapter                                                                                                                                                                | 112/85, ESCALA PL 250R-VL or ESCALA PL 450R-XS, ESCALA PL 250R-L+ or ESCALA PL 450R-VL+, ESCALA PL 250T/R+ or ESCALA PL 450T/R-L+, ESCALA PL 450T/R+ or ESCALA PL 850T/R-L+, ESCALA PL 1650R-L+, 7/20 | 80P6513                       |
|      | PCI adapter                                                                                                                                                                | 112/85, ESCALA PL 250R-VL or ESCALA PL 450R-XS, ESCALA PL 250R-L+ or ESCALA PL 450R-VL+, ESCALA PL 250T/R+ or ESCALA PL 450T/R-L+, ESCALA PL 450T/R+ or ESCALA PL 850T/R-L+, ESCALA PL 1650R-L+, 7/20 | 80P6508                       |
|      | DIMM cover                                                                                                                                                                 | 9406-570, ESCALA PL 850R/PL 1650R/R+                                                                                                                                                                  | 97P6896                       |
|      | Adapter                                                                                                                                                                    | ESCALA PL 245T/R                                                                                                                                                                                      | 52P8456                       |
|      | Adapter assembly                                                                                                                                                           | ESCALA PL 245T/R                                                                                                                                                                                      | 52P8480                       |
|      | IDE cable                                                                                                                                                                  | ESCALA PL 245T/R                                                                                                                                                                                      | 36R2522                       |
|      | SCSI cable                                                                                                                                                                 | ESCALA PL 245T/R                                                                                                                                                                                      | 36R2524                       |
|      | Adapter card                                                                                                                                                               | 112/85, ESCALA PL 250R-VL or ESCALA PL 450R-XS, ESCALA PL 250R-L+ or ESCALA PL 450R-VL+, ESCALA PL 250T/R+ or ESCALA PL 450T/R-L+, ESCALA PL 450T/R+ or ESCALA PL 850T/R-L+, ESCALA PL 1650R-L+, 7/20 | 03N6970                       |
|      | Adapter card                                                                                                                                                               | 112/85, ESCALA PL 250R-VL or ESCALA PL 450R-XS, ESCALA PL 250R-L+ or ESCALA PL 450R-VL+, ESCALA PL 250T/R+ or ESCALA PL 450T/R-L+, ESCALA PL 450T/R+ or ESCALA PL 850T/R-L+, ESCALA PL                | 03N6972                       |

## Service provider information

|  |  |                                              |                                                                                                                                                                                                                                                                                                                                                                                       |         |
|--|--|----------------------------------------------|---------------------------------------------------------------------------------------------------------------------------------------------------------------------------------------------------------------------------------------------------------------------------------------------------------------------------------------------------------------------------------------|---------|
|  |  |                                              | 1650R-L+, 7/20                                                                                                                                                                                                                                                                                                                                                                        |         |
|  |  | Adapter card                                 | ESCALA PL 245T/R, ESCALA PL 250R-VL or ESCALA PL 450R-XS, ESCALA PL 250R-L, ESCALA PL 250R-L+ or ESCALA PL 450R-VL+, ESCALA PL 250T/R+ or ESCALA PL 450T/R-L+, 9405-520, 9406-520, ESCALA PL 250T/R, ESCALA PL 450T/R+ or ESCALA PL 850T/R-L+, 9406-550, ESCALA PL 450T/R, ESCALA PL 1650R-L+, 9406-570, ESCALA PL 850R/PL 1650R/R+, ESCALA PL 3250R, ESCALA PL 6450R, 9406-595, 7/20 | 03N6973 |
|  |  | GXT adapter with digital port                | ESCALA PL 245T/R, ESCALA PL 250R-VL or ESCALA PL 450R-XS, ESCALA PL 250R-L+ or ESCALA PL 450R-VL+, ESCALA PL 250T/R+ or ESCALA PL 450T/R-L+, ESCALA PL 450T/R+ or ESCALA PL 850T/R-L+, ESCALA PL 1650R-L+                                                                                                                                                                             | 03N5855 |
|  |  | Ethernet adapter, copper                     | ESCALA PL 245T/R, ESCALA PL 250R-VL or ESCALA PL 450R-XS, ESCALA PL 250R-L, ESCALA PL 250R-L+ or ESCALA PL 450R-VL+, ESCALA PL 250T/R+ or ESCALA PL 450T/R-L+, ESCALA PL 450T/R+ or ESCALA PL 850T/R-L+, ESCALA PL 1650R-L+, 7/20                                                                                                                                                     | 30R5219 |
|  |  | Ethernet adapter, dual port, fiber           | ESCALA PL 245T/R, ESCALA PL 250R-VL or ESCALA PL 450R-XS, ESCALA PL 250R-L, ESCALA PL 250R-L+ or ESCALA PL 450R-VL+, ESCALA PL 250T/R+ or ESCALA PL 450T/R-L+, ESCALA PL 450T/R+ or ESCALA PL 850T/R-L+, ESCALA PL 1650R-L+, 7/20                                                                                                                                                     | 30R5519 |
|  |  | Air baffle                                   | ESCALA PL 245T/R, 471/85                                                                                                                                                                                                                                                                                                                                                              | 42R4150 |
|  |  | Baffle                                       | ESCALA PL 245T/R, 471/85                                                                                                                                                                                                                                                                                                                                                              | 53P2654 |
|  |  | PCI adapter, 4 GBS, short, 2 port            | ESCALA PL 245T/R, 471/85                                                                                                                                                                                                                                                                                                                                                              | 03N5020 |
|  |  | PCI adapter, 2 GBS, short, 2 port            | ESCALA PL 245T/R, 471/85                                                                                                                                                                                                                                                                                                                                                              | 03N7067 |
|  |  | Ethernet adapter (fiber), short              | ESCALA PL 245T/R, ESCALA PL 250R-VL or ESCALA PL 450R-XS, ESCALA PL 250R-L+ or ESCALA PL 450R-VL+, ESCALA PL 250T/R+ or ESCALA PL 450T/R-L+, ESCALA PL 450T/R+ or ESCALA PL 850T/R-L+, ESCALA PL 1650R-L+, 7/20                                                                                                                                                                       | 03N6982 |
|  |  | Ethernet adapter, 10/100/1000, short, 4 port | ESCALA PL 245T/R, ESCALA PL 250R-VL or ESCALA PL 450R-XS, ESCALA PL 250R-L, ESCALA PL 250R-L+ or ESCALA PL 450R-VL+, ESCALA PL 250T/R+ or ESCALA PL 450T/R-L+, ESCALA PL 450T/R+ or ESCALA PL 850T/R-L+, ESCALA PL 1650R-L+, 7/20                                                                                                                                                     | 03N5446 |
|  |  | Ethernet adapter (UTP), short                | ESCALA PL 245T/R, ESCALA PL 250R-VL or ESCALA PL 450R-XS, ESCALA PL 250R-L+ or ESCALA PL 450R-VL+, ESCALA PL 250T/R+ or ESCALA PL 450T/R-L+, ESCALA PL 450T/R+ or ESCALA PL 850T/R-L+,                                                                                                                                                                                                | 03N6525 |

## Service provider information

|  |  |                                            |                                                                                                                                                                                                                                                                                                                                                                                              |         |
|--|--|--------------------------------------------|----------------------------------------------------------------------------------------------------------------------------------------------------------------------------------------------------------------------------------------------------------------------------------------------------------------------------------------------------------------------------------------------|---------|
|  |  |                                            | ESCALA PL 1650R-L+, 7/20                                                                                                                                                                                                                                                                                                                                                                     |         |
|  |  | Ethernet adapter (UTP), short, dual port   | ESCALA PL 245T/R, ESCALA PL 250R-VL or ESCALA PL 450R-XS, ESCALA PL 250R-L+ or ESCALA PL 450R-VL+, ESCALA PL 250T/R+ or ESCALA PL 450T/R-L+, ESCALA PL 450T/R+ or ESCALA PL 850T/R-L+, ESCALA PL 1650R-L+, 7/20                                                                                                                                                                              | 03N5298 |
|  |  | Ethernet adapter (fiber), short, dual port | ESCALA PL 245T/R, ESCALA PL 250R-VL or ESCALA PL 450R-XS, ESCALA PL 250R-L+ or ESCALA PL 450R-VL+, ESCALA PL 250T/R+ or ESCALA PL 450T/R-L+, ESCALA PL 450T/R+ or ESCALA PL 850T/R-L+, ESCALA PL 1650R-L+, 7/20                                                                                                                                                                              | 03N6974 |
|  |  | PCI adapter, 4 GB, short, 1 port           | ESCALA PL 245T/R, ESCALA PL 250R-VL or ESCALA PL 450R-XS, ESCALA PL 250R-L, ESCALA PL 250R-L+ or ESCALA PL 450R-VL+, ESCALA PL 250T/R+ or ESCALA PL 450T/R-L+, ESCALA PL 450T/R+ or ESCALA PL 850T/R-L+, ESCALA PL 1650R-L+, 7/20                                                                                                                                                            | 03N5005 |
|  |  | GX adapter, short                          | ESCALA PL 245T/R, ESCALA PL 250R-VL or ESCALA PL 450R-XS, ESCALA PL 250R-L, ESCALA PL 250R-L+ or ESCALA PL 450R-VL+, ESCALA PL 250T/R+ or ESCALA PL 450T/R-L+, 9405-520, 9406-520, ESCALA PL 250T/R, ESCALA PL 450T/R+ or ESCALA PL 850T/R-L+, 9406-550, ESCALA PL 450T/R, ESCALA PL 1650R-L+, 9406-570, ESCALA PL 850R/PL 1650R/R+, ESCALA PL 3250R, ESCALA PL 6450R, 9406-595, 7/20        | 03N5853 |
|  |  | Ethernet adapter (fiber), short            | ESCALA PL 245T/R 471/85, ESCALA PL 250R-VL or ESCALA PL 450R-XS, ESCALA PL 250R-L, ESCALA PL 250R-L+ or ESCALA PL 450R-VL+, ESCALA PL 250T/R+ or ESCALA PL 450T/R-L+, 9405-520, 9406-520, ESCALA PL 250T/R, ESCALA PL 450T/R+ or ESCALA PL 850T/R-L+, 9406-550, ESCALA PL 450T/R, ESCALA PL 1650R-L+, 9406-570, ESCALA PL 850R/PL 1650R/R+, ESCALA PL 3250R, ESCALA PL 6450R, 9406-595, 7/20 | 03N6981 |
|  |  | Ethernet adapter (UTP), short              | ESCALA PL 245T/R 471/85, ESCALA PL 250R-VL or ESCALA PL 450R-XS, ESCALA PL 250R-L, ESCALA PL 250R-L+ or ESCALA PL 450R-VL+, ESCALA PL 250T/R+ or ESCALA PL 450T/R-L+, 9405-520, 9406-520, ESCALA PL 250T/R, ESCALA PL 450T/R+ or ESCALA PL 850T/R-L+, 9406-550, ESCALA PL 450T/R, ESCALA PL 1650R-L+, 9406-570, ESCALA PL 850R/PL 1650R/R+, ESCALA PL 3250R, ESCALA PL 6450R, 9406-595, 7/20 | 03N6524 |
|  |  | Audio card                                 | ESCALA PL 245T/R, ESCALA PL 250T/R+ or ESCALA PL 450T/R-L+,                                                                                                                                                                                                                                                                                                                                  | 80P2598 |

Service provider information

|  |  |                                      |                                                                                                                                                                                                                                                                                                                                                                             |         |
|--|--|--------------------------------------|-----------------------------------------------------------------------------------------------------------------------------------------------------------------------------------------------------------------------------------------------------------------------------------------------------------------------------------------------------------------------------|---------|
|  |  |                                      | 9405-520, 9406-520, ESCALA PL 250T/R                                                                                                                                                                                                                                                                                                                                        |         |
|  |  | USB mouse                            | ESCALA PL 245T/R, ESCALA PL 250R-VL or ESCALA PL 450R-XS, ESCALA PL 250R-L, ESCALA PL 250R-L+ or ESCALA PL 450R-VL+, ESCALA PL 250T/R+ or ESCALA PL 450T/R-L+, 9405-520, 9406-520, ESCALA PL 250T/R, ESCALA PL 450T/R+ or ESCALA PL 850T/R-L+, 9406-550, ESCALA PL 450T/R, ESCALA PL 1650R-L+, 9406-570, ESCALA PL 850R/PL 1650R/R+, ESCALA PL 3250R, ESCALA PL 6450R, 7/20 | 09N5532 |
|  |  | Rack-mount drawer bezel and hardware | , ,                                                                                                                                                                                                                                                                                                                                                                         | 97P6799 |
|  |  | Door                                 | , ,                                                                                                                                                                                                                                                                                                                                                                         | 12R8665 |

Non-storage IOA and IOP parts

| CCIN or Type | Failing Function Code | Description                                                                                                              | Model, expansion unit, or unit type | Part number                                                                      |
|--------------|-----------------------|--------------------------------------------------------------------------------------------------------------------------|-------------------------------------|----------------------------------------------------------------------------------|
| 2058         |                       | PCI cryptographic coprocessor                                                                                            | All                                 | 11P3106                                                                          |
| 2723         |                       | Ethernet IOA                                                                                                             | All                                 | 21H9201                                                                          |
| 2742         |                       | 2-line communications IOA                                                                                                | All                                 | 39J2298                                                                          |
| 2743         |                       | Ethernet 1 Gb/sec IOA                                                                                                    | All                                 | 09P2098                                                                          |
| 2744         |                       | Token ring 100 Mb/sec IOA                                                                                                | All                                 | 23L4288                                                                          |
| 2745         |                       | Multiline communications IOA                                                                                             | All                                 | 21H5490                                                                          |
| 2746         |                       | Twinaxial IOA                                                                                                            | All                                 | 39J3707                                                                          |
| 2750         |                       | ISDN communications IOA                                                                                                  | All                                 | 97H7674                                                                          |
| 2751         |                       | ISDN communications IOA                                                                                                  | All                                 | 97H7675                                                                          |
| 2760         |                       | Ethernet 1 Gigabit/sec IOA                                                                                               | All                                 | 00P1690                                                                          |
| 2761         |                       | Integrated modem IOA<br><br>1. United States<br>2. Europe<br>3. Germany<br>4. Australia<br>5. Spain<br>6. Czechoslovakia | All                                 | 1. 97H7678<br>2. 97H7679<br>3. 97H7680<br>4. 97H7681<br>5. 97H7682<br>6. 97H7683 |
| 2771         |                       | V.90 WAN IOA<br><br>1. All <i>except</i> Australia, New Zealand<br>2. Australia, New Zealand                             | All                                 | 1. 04N4519<br>2. 04N4520                                                         |

Service provider information

|                            |  |                                                                                                         |                  |                                                    |
|----------------------------|--|---------------------------------------------------------------------------------------------------------|------------------|----------------------------------------------------|
| 2772                       |  | Two-port V.90 socket modem IOA<br><br>1. All EXCEPT Australia, New Zealand<br>2. Australia, New Zealand | All              | 1. 04N4537<br>2. 04N4539                           |
| 2793                       |  | V.92 communications IOA<br><br>1. All EXCEPT Australia, New Zealand<br>2. Australia, New Zealand        | All              | 1. 39J2282<br>2. 39J2286                           |
| 2805                       |  | 4-port V.92 communications IOA<br><br>1. All EXCEPT Australia, New Zealand<br>2. Australia, New Zealand | All              | 1. 21P8186<br>2. 21P8190                           |
| 2838                       |  | 100 Mbps Ethernet IOA                                                                                   | All              | 21H5460                                            |
| 2842                       |  | Combined function IOP - 32 MB                                                                           | All              | 04N5090                                            |
| 2843                       |  | Combined function IOP - 64 MB                                                                           | All              | 04N5095                                            |
| 2844                       |  | Combined function IOP - 64 MB                                                                           | All              | 21P6018                                            |
| 2849                       |  | 10/100 Mbps Ethernet IOA                                                                                | All              | 53P0057                                            |
| 1. 4758-001<br>2. 4758-001 |  | 1. PCI cryptographic coprocessor<br>2. PCI cryptographic coprocessor battery kit                        | 1. All<br>2. All | 1. 10J0410<br>2. 09J8199                           |
| 1. 4758-023<br>2. 4758-023 |  | 1. PCI cryptographic coprocessor<br>2. PCI cryptographic coprocessor battery kit                        | 1. All<br>2. All | 1. 10J0593<br>2. 09J8199<br>(need to order 2 kits) |
| 1. 4764-001<br>2. 4764-001 |  | 1. PCI cryptographic coprocessor<br>2. PCI cryptographic coprocessor battery kit                        | ''''''           | 1. 41U0442<br>2. 41V1061                           |
| 5700                       |  | Ethernet 1 GB/sec IOA                                                                                   | All              | 09P5386                                            |
| 5701                       |  | Ethernet 1 GB/sec IOA                                                                                   | All              | 09P5389                                            |
| 5706                       |  | 1Gbps Ethernet-TX IOA (UTP)                                                                             | All              | 03N5297                                            |
| 5707                       |  | Ethernet 1 GB/sec IOA                                                                                   | All              | 03N6973                                            |

**Power parts**

| CCIN | Description | Model, expansion unit, or unit type | Part number |
|------|-------------|-------------------------------------|-------------|
|------|-------------|-------------------------------------|-------------|

Service provider information

|      | Failing Function Code |                                                                                   |                                                                                                                                                                              |                    |
|------|-----------------------|-----------------------------------------------------------------------------------|------------------------------------------------------------------------------------------------------------------------------------------------------------------------------|--------------------|
|      | 166                   | Fan assembly or blower                                                            | ESCALA PL 250T/R, ESCALA PL 450T/R, ESCALA PL 850R/PL 1650R/R+                                                                                                               |                    |
|      |                       | Blower                                                                            | , , , , ,                                                                                                                                                                    | 41V0641            |
|      |                       | Drawer fan                                                                        | 11D/10                                                                                                                                                                       | 09P3354            |
|      |                       | Drawer fan                                                                        | 11D/11                                                                                                                                                                       |                    |
|      |                       | Drawer fan                                                                        | 11D/20                                                                                                                                                                       | 39J1176            |
|      |                       | AC input/battery charger                                                          | 50/74 or 50/79 (single line cord), 9074, 9079                                                                                                                                | 97H7316            |
|      |                       | AC module                                                                         | 50/74 or 50/79 (2 power supply dual line cord)                                                                                                                               | 21P6347            |
|      |                       | AC module                                                                         | 50/94, 82/94                                                                                                                                                                 | 39J5171            |
|      |                       | Battery power unit                                                                | 50/74, 50/79                                                                                                                                                                 | 97H7318            |
|      |                       | Bulk power controller (BPC) assembly                                              | 5/75, ESCALA PL 3250R, ESCALA PL 6450R                                                                                                                                       | 41V0355            |
|      |                       | Bulk power distribution (BPD) assembly                                            | 5/75, ESCALA PL 3250R, ESCALA PL 6450R                                                                                                                                       | 12R9722            |
|      |                       | Bulk power jumper (BPJ) assembly                                                  | 5/75                                                                                                                                                                         | 41V0426            |
|      |                       | Bulk power hub (BPH) assembly                                                     | 5/75                                                                                                                                                                         | 12R9704            |
|      |                       | Bulk power distribution fan                                                       | ESCALA PL 3250R, ESCALA PL 6450R, 5/75                                                                                                                                       | 12R9323            |
|      |                       | Bulk power regulator (BPR) assembly                                               | , ,                                                                                                                                                                          | 15R6711            |
|      | 684                   | Enhanced remote asynchronous node, 16-Port RS-422 power supply, remote async node | All                                                                                                                                                                          | 93H6563<br>80P3869 |
| 28E8 |                       | Voltage regulator                                                                 | ESCALA PL 850R/PL 1650R/R+                                                                                                                                                   | 39J2557            |
|      | 152                   | Power supply                                                                      | ESCALA PL 250R-L, 7/10                                                                                                                                                       | 39J4710            |
|      | 287                   | Power supply (850 W redundant)                                                    | ESCALA PL 250T/R, ESCALA PL 250T/R+ or ESCALA PL 450T/R-L+                                                                                                                   | 39J4951            |
| 51BA | 289                   | Power supply                                                                      | ESCALA PL 450T/R, 7/20                                                                                                                                                       | 39J5638            |
|      |                       | Power supply                                                                      | ESCALA PL 850R/PL 1650R/R+                                                                                                                                                   | 39J2779            |
|      |                       | Power supply                                                                      |                                                                                                                                                                              | 41V1227            |
|      |                       | Power supply                                                                      | 50/88, 05/88                                                                                                                                                                 | 00P3918            |
|      |                       | Power supply                                                                      | 50/95, 05/95                                                                                                                                                                 | 21P7602            |
|      |                       | Power supply                                                                      | 50/74, 50/79, 50/94, 52/94, 8093, 8094, 82/94                                                                                                                                | 39J5273            |
|      |                       | Power supply                                                                      | 57/90, 11D/11                                                                                                                                                                | 09P3354            |
|      |                       | Power supply                                                                      | 11D/20                                                                                                                                                                       | 39J2781            |
| 51B6 |                       | Power supply, 850 W                                                               | , , ,                                                                                                                                                                        | 39J4951            |
|      |                       | Time of day battery                                                               | All                                                                                                                                                                          | 16G8095            |
|      |                       | 1.3 V voltage regulator                                                           | ,                                                                                                                                                                            | 39J5065            |
|      |                       | 1.8 V voltage regulator                                                           | 112/85, ESCALA PL 250R-VL or ESCALA PL 450R-XS, ESCALA PL 250T/R, ESCALA PL 250T/R+ or ESCALA PL 450T/R-L+, ESCALA PL 450T/R, ESCALA PL 450T/R+ or ESCALA PL 850T/R-L+, 7/20 | 39J5185            |



## Service provider information

|      |                                                                                                                                                                                                                                                                                                                                |                                                                                                                                                                                                |                    |
|------|--------------------------------------------------------------------------------------------------------------------------------------------------------------------------------------------------------------------------------------------------------------------------------------------------------------------------------|------------------------------------------------------------------------------------------------------------------------------------------------------------------------------------------------|--------------------|
|      | 2.5 V voltage regulator                                                                                                                                                                                                                                                                                                        | 112/85, ESCALA PL 250R-VL or ESCALA PL 450R-XS, ESCALA PL 250R-L, ESCALA PL 250T/R+ or ESCALA PL 450T/R-L+, ESCALA PL 250T/R, ESCALA PL 450T/R+ or ESCALA PL 850T/R-L+, ESCALA PL 450T/R, 7/20 | 03N6792            |
|      | Regulator card                                                                                                                                                                                                                                                                                                                 | , , ,                                                                                                                                                                                          | 39J3615            |
|      | 1.3 V voltage regulator                                                                                                                                                                                                                                                                                                        | ESCALA PL 250R-L, 7/10                                                                                                                                                                         | 24R2696            |
| 11A  | Battery kit, cryptographic coprocessor                                                                                                                                                                                                                                                                                         |                                                                                                                                                                                                | 09J8199            |
| 151  | Battery, time-of-day, NVRAM, etc.<br><br><b>Notes:</b> After replacing FRU do the following:<br><br>1. Set time and date.<br>2. Set network IP addresses (for machines that IPL from a network).<br>3. Set the bootlist to reflect the customer's preference for the IPL devices (when it is different from the default list). |                                                                                                                                                                                                |                    |
| 153  | Device drawer, exp unit pwr sup                                                                                                                                                                                                                                                                                                |                                                                                                                                                                                                |                    |
| 167  | Power supply (fan)                                                                                                                                                                                                                                                                                                             | ESCALA PL 250T/R, ESCALA PL 450T/R, ESCALA PL 850R/PL 1650R/R+                                                                                                                                 |                    |
| 192  | Power supply, portable disk drive                                                                                                                                                                                                                                                                                              | 7203                                                                                                                                                                                           | 00G2960            |
| E30  | 32 MB cache Battery (Located on the LVD SCSI RAID adapter)                                                                                                                                                                                                                                                                     |                                                                                                                                                                                                | 44H8429            |
| E3A  | 128 MB cache battery, U.S.<br>128 MB cache battery, Japan                                                                                                                                                                                                                                                                      |                                                                                                                                                                                                | 37L6903<br>00N9561 |
| 2526 | PCI-X ultra320 SCSI RAID Battery Pack                                                                                                                                                                                                                                                                                          |                                                                                                                                                                                                | 44L0313            |
| 2D01 | PCI-X quad channel U320 SCSI RAID battery pack                                                                                                                                                                                                                                                                                 |                                                                                                                                                                                                | 39J5554            |
|      | Power supply, 700 W                                                                                                                                                                                                                                                                                                            | 112/85, ESCALA PL 250T/R+ or ESCALA PL 450T/R-L+                                                                                                                                               | 39J0271            |
|      | Power supply                                                                                                                                                                                                                                                                                                                   | ESCALA PL 250R-VL or ESCALA PL 450R-XS                                                                                                                                                         | 39J5045            |
|      | Power supply                                                                                                                                                                                                                                                                                                                   | ESCALA PL 250T/R, ESCALA PL 250T/R+ or ESCALA PL 450T/R-L+                                                                                                                                     | 39J4951            |
|      | Power supply (processor 42R5210)                                                                                                                                                                                                                                                                                               | ESCALA PL 245T/R, 1/85                                                                                                                                                                         | 42R4458            |
|      | Power supply (processor 42R5211 )                                                                                                                                                                                                                                                                                              | ESCALA PL 245T/R, 1/85                                                                                                                                                                         | 39J4298            |





Service provider information

|                                    |     |                                                                                                                                                                           |                                                      |                                                     |
|------------------------------------|-----|---------------------------------------------------------------------------------------------------------------------------------------------------------------------------|------------------------------------------------------|-----------------------------------------------------|
|                                    |     | cover.                                                                                                                                                                    |                                                      |                                                     |
| 6386                               |     | Internal 1/4 inch cartridge drive with MLR3 on the front cover.                                                                                                           | 50/74, 50/79, 50/94, 52/94, 82/94 expansion units    | 53P2386                                             |
|                                    |     |                                                                                                                                                                           | All other expansion units                            | 59H4130                                             |
| 6387                               |     | Internal 1/4 inch cartridge drive with SLR100 on the front cover.                                                                                                         | ESCALA PL 250T/R                                     | 09L5276                                             |
|                                    |     |                                                                                                                                                                           | 50/74, 50/79, 50/94, 52/94, 82/94 expansion units    | 53P2650                                             |
| 7207 Model 122                     |     | External 1/4 inch cartridge drive with QIC-4GB-DC on the door                                                                                                             | All                                                  | 59H4434                                             |
| 7208<br>7208 models -342 and -345. |     | External 8 mm tape drive.                                                                                                                                                 |                                                      | Refer to the device service information.            |
| 7239 model 308                     |     | External 1/4 inch cartridge tape library                                                                                                                                  |                                                      | Refer to the device service information.            |
| 9348                               |     | External 1/2 inch reel tape unit.                                                                                                                                         | Refer to the <a href="#">instructions for 9348</a> . |                                                     |
|                                    | 458 | 36 GB DAT tape drive                                                                                                                                                      |                                                      | 71P9163                                             |
|                                    | 459 | 36 GB DAT tape drive                                                                                                                                                      |                                                      | 95P1988                                             |
|                                    | 45D | 200 GB HH LTO2 tape drive                                                                                                                                                 |                                                      | 24R0305                                             |
|                                    | 541 | 7205-440 40 GB tape drive<br>7337-360 40 GB tape drive                                                                                                                    |                                                      | 19P2042<br>19P1629                                  |
|                                    | 542 | When replacing a 7208-345 60 GB tape drive or a 7334-410 60 GB tape drive in an o/p system go to <a href="#">542</a> .                                                    |                                                      |                                                     |
|                                    |     | 7208-345 60 GB tape drive<br>7334-410 60 GB tape drive                                                                                                                    |                                                      | 19P0708<br>19P0207                                  |
|                                    | 613 | 8 mm 80 GB VXA-2 tape device                                                                                                                                              |                                                      | 95P1871                                             |
|                                    | 678 | 12 GB 4 mm SCSI tape drive                                                                                                                                                |                                                      | 59H3879                                             |
|                                    | 68C | 20 GB 4 mm tape drive                                                                                                                                                     |                                                      | 19P0802                                             |
|                                    | 692 | 7205-311 35 GB DLT tape drive, 3447-105 35 GB DLT tape drive, 3447-106 35 GB DLT tape drive, 7337-305 35 GB DLT tape drive, 7337-306 35 GB DLT tape drive                 |                                                      | 59H3121<br>59H3569<br>59H3569<br>59H3570<br>59H3570 |
|                                    | 724 | Unknown tape drive                                                                                                                                                        |                                                      |                                                     |
|                                    | 733 | 140 GB 8 mm tape library                                                                                                                                                  |                                                      | 59H3161                                             |
|                                    | 745 | 16 GB DDS-2 tape cartridge auto loader<br>48 GB DDS-3 tape cartridge auto loader<br><br><b>Note:</b> Service documentation for this device supplies the FRU part numbers. |                                                      |                                                     |

## Service provider information

|      |                                                                                                                                                                                                                     |  |                                          |
|------|---------------------------------------------------------------------------------------------------------------------------------------------------------------------------------------------------------------------|--|------------------------------------------|
| 749  | 7331 model 205 8 mm tape library<br><br><b>Note:</b> For FRU numbers, refer to the service documentation for this device.                                                                                           |  |                                          |
| 757  | SCSI 13 GB 1/4 inch tape drive                                                                                                                                                                                      |  | 87G4858                                  |
| 783  | 24/48 GB DDS-2 4 mm tape autoloader (vertical orientation)<br>24/48 GB DDS-2 4 mm tape autoloader (horizontal orientation)<br>tape magazine                                                                         |  | 76H0473<br>76H0474<br>41H8714            |
| 914  | 5 GB 8 mm SCSI DE tape drive                                                                                                                                                                                        |  | 16G8492                                  |
| 915  | 4/8 GB 4 mm tape drive                                                                                                                                                                                              |  | 59H3481                                  |
| 964  | 20 GB 8 mm SE SCSI tape drive (internal, white)<br>20 GB 8 mm SE SCSI tape drive (internal, black)<br>20 GB 8 mm Diff SCSI tape drive (external/white)<br>400 GB 8 mm Diff tape autoloader (No LCD in bezel/ white) |  | 59H2839<br>59H4120<br>59H2835<br>59H2842 |
| 970  | 1/2-inch 9-track tape drive<br>use device documentation                                                                                                                                                             |  |                                          |
| 971  | 150 MB 1/4 inch tape drive                                                                                                                                                                                          |  | 16G8423                                  |
| 972  | 2.3 GB 8 mm tape drive                                                                                                                                                                                              |  | 16G8421                                  |
| 973  | Other SCSI tape drive                                                                                                                                                                                               |  |                                          |
| 991  | 525 MB 1/4 inch SCSI tape drive                                                                                                                                                                                     |  | 46G2700                                  |
| 994  | ESCALA PL 250R-L GB 8 mm internal tape drive                                                                                                                                                                        |  | 59H3159                                  |
| 995  | 1.2 GB 1/4 inch cartridge tape drive                                                                                                                                                                                |  | 21H5155                                  |
| 998  | 2.0 GB 4 mm SCSI tape drive                                                                                                                                                                                         |  | 8191193                                  |
| 2611 | When replacing an INT 4 mm 36/72 GB tape drive in an o/p system go to <a href="#">2611</a> .                                                                                                                        |  |                                          |
| 2612 | When replacing an VXA2 80/160 GB tape drive in an o/p system go to <a href="#">2612</a> .                                                                                                                           |  |                                          |
| 2613 | 200/400 GB LTO2 Tape drive                                                                                                                                                                                          |  | 23R3248                                  |
|      | When replacing a 200/400 GB LTO2 tape drive in an o/p system go to <a href="#">2613</a>                                                                                                                             |  |                                          |

## Service provider information

|  |      |                                                                                         |                                                                                                                                                               |                                                                     |
|--|------|-----------------------------------------------------------------------------------------|---------------------------------------------------------------------------------------------------------------------------------------------------------------|---------------------------------------------------------------------|
|  | 2614 | VXA3 160/320 GB Tape drive                                                              |                                                                                                                                                               | 95P1976                                                             |
|  |      | When replacing a VXA3 160/320 GB tape drive in an o/p system go to <a href="#">2614</a> |                                                                                                                                                               |                                                                     |
|  |      | DVD ROM slimline                                                                        | ESCALA PL 250R-VL or ESCALA PL 450R-XS                                                                                                                        | 03N4536                                                             |
|  |      | CD with hardware                                                                        | ESCALA PL 245T/R                                                                                                                                              | 36R2528                                                             |
|  |      | CD ROM                                                                                  | ESCALA PL 245T/R                                                                                                                                              | 52P8425,<br>52P8426,<br>09P0736,<br>36R2549,<br>36R2544,<br>40N9818 |
|  | 2584 | IDE DVD RAM                                                                             | ESCALA PL 245T/R, 471/85                                                                                                                                      | 97P6888                                                             |
|  | 2585 | IDE DVD ROM                                                                             | ESCALA PL 245T/R, 471/85                                                                                                                                      | 03N6667                                                             |
|  |      | IDE DVD RAM, slimline                                                                   | 112/85, ESCALA PL 250R-L+ or ESCALA PL 450R-VL+, ESCALA PL 250T/R+ or ESCALA PL 450T/R-L+, ESCALA PL 450T/R+ or ESCALA PL 850T/R-L+, ESCALA PL 1650R-L+, 7/20 | 80P6341                                                             |
|  |      | IDE DVD ROM, slimline                                                                   | 112/85, ESCALA PL 250R-L+ or ESCALA PL 450R-VL+, ESCALA PL 250T/R+ or ESCALA PL 450T/R-L+, ESCALA PL 450T/R+ or ESCALA PL 850T/R-L+, ESCALA PL 1650R-L+, 7/10 | 03N4712                                                             |
|  |      | DVD ROM                                                                                 | , , , ,                                                                                                                                                       | 07L8782                                                             |

## Storage parts

| CCIN | Failing Function Code | Description                                                                                                                                   | Model, expansion unit, or unit type | Part number                                                        |
|------|-----------------------|-----------------------------------------------------------------------------------------------------------------------------------------------|-------------------------------------|--------------------------------------------------------------------|
| 2748 |                       | Storage IOA<br>1. Card (non-Japan)<br>2. Card (Japan)<br>3. Cache battery pack (non-Japan)<br>4. Cache battery pack (Japan)<br>5. Mode jumper | All                                 | 1. 91H3987<br>2. 23L2841<br>3. 44L0302<br>4. 44L0301<br>5. 23L3442 |
| 2749 |                       | Storage IOA (external removable media)                                                                                                        | All                                 | 04N2296                                                            |
| 2757 |                       | Storage IOA<br>1. Card<br>2. Cache battery pack                                                                                               | All                                 | 1. 21P5899<br>2. 53P0941                                           |
| 2763 |                       | Storage IOA                                                                                                                                   | All                                 |                                                                    |

## Service provider information

|      |  |                                                                                                                             |                                                                |                                                                 |
|------|--|-----------------------------------------------------------------------------------------------------------------------------|----------------------------------------------------------------|-----------------------------------------------------------------|
|      |  | 1. Card<br>2. Cache battery pack                                                                                            |                                                                | 1. 91H4082<br>2. 44L0313                                        |
| 2765 |  | Fibre Channel IOA (for removable media attachment only)                                                                     | All                                                            | 03N2451                                                         |
| 2766 |  | Fibre Channel IOA (for disk drive attachment only)                                                                          | All                                                            | 80P4385                                                         |
| 2767 |  | Storage IOA                                                                                                                 | All                                                            | 04N2304                                                         |
| 2778 |  | Storage IOA<br><br>1. Card<br>2. Cache battery pack<br>3. Mode jumper                                                       | All                                                            | 1. 21P3735<br>2. 44L0313<br>3. 23L3442                          |
| 2780 |  | Storage IOA<br><br>1. Card<br>2. Cache battery pack                                                                         | All                                                            | 1. 39J5581<br>2. 39J5554                                        |
| 2782 |  | Storage IOA<br><br>1. Card<br>2. Cache battery pack                                                                         | All                                                            | 1. 21P6477<br>2. 44L0313                                        |
| 2787 |  | Fibre Channel IOA (for disk drive attachment only)                                                                          | All                                                            | 00P4339                                                         |
| 280D |  | Fibre Channel IOA (for removable media attachment only)                                                                     | All                                                            | 03N5014                                                         |
| 280E |  | Fibre Channel IOA (for disk drive attachment only)                                                                          | All                                                            | 03N5016                                                         |
| 2847 |  | Fibre Channel IOP                                                                                                           | All                                                            | 39J2513                                                         |
| 5702 |  | Storage IOA                                                                                                                 | All                                                            | 53P0978                                                         |
| 5703 |  | Storage IOA<br><br>1. Card<br>2. Cache battery pack                                                                         | All                                                            | 1. 53P3880<br>2. 44L0313                                        |
| 5704 |  | Fibre Channel IOA (for removable media attachment only)                                                                     | All                                                            | 00P4297                                                         |
| 5708 |  | Auxiliary cache adapter<br><br>1. Card<br>2. Auxiliary cache to SCSI adapter cable (FC 5580, 5581)<br>3. Cache battery pack | All                                                            | 1. 39J5584<br>2. 42R4053<br>3. 39J5554                          |
| 5709 |  | RAID enablement card                                                                                                        | 9406-520, 9406-550                                             | 97P2823                                                         |
|      |  |                                                                                                                             | 9406-570, ESCALA PL 850R/PL 1650R/R+                           | 97P3158                                                         |
|      |  | Battery pack                                                                                                                | All                                                            | 44L0313                                                         |
| 570B |  | Imbedded storage IOA                                                                                                        | ESCALA PL 250T/R, ESCALA PL 450T/R, ESCALA PL 850R/PL 1650R/R+ | Replace the system backplane (see <a href="#">Backplanes</a> ). |
| 570C |  | Imbedded storage IOA                                                                                                        | ESCALA PL 850R/PL 1650R/R+                                     | Replace the I/O backplane (see <a href="#">Backplanes</a> ).    |
| 571A |  | Storage IOA                                                                                                                 |                                                                | 42R4860                                                         |

Service provider information

|      |  |                                                                                                                                                  |                                                                                                                                                                                                                                                                                                                                               |                                                      |
|------|--|--------------------------------------------------------------------------------------------------------------------------------------------------|-----------------------------------------------------------------------------------------------------------------------------------------------------------------------------------------------------------------------------------------------------------------------------------------------------------------------------------------------|------------------------------------------------------|
|      |  |                                                                                                                                                  | ESCALA PL 245T/R, ESCALA PL 250R-VL or ESCALA PL 450R-XS, ESCALA PL 250R-L, ESCALA PL 250R-L+ or ESCALA PL 450R-VL+, ESCALA PL 250T/R+ or ESCALA PL 450T/R-L+, 9405-520, 9406-520, ESCALA PL 250T/R, ESCALA PL 450T/R+ or ESCALA PL 850T/R-L+, 9406-550, ESCALA PL 450T/R, ESCALA PL 1650R-L+, 9406-570, ESCALA PL 850R/PL 1650R/R+, 9406-595 |                                                      |
| 571B |  | Storage IOA<br>1. Card<br>2. Cache battery pack                                                                                                  | ESCALA PL 245T/R, ESCALA PL 250R-L, ESCALA PL 250R-L+ or ESCALA PL 450R-VL+, ESCALA PL 250T/R+ or ESCALA PL 450T/R-L+, 9405-520, 9406-520, ESCALA PL 250T/R, ESCALA PL 450T/R+ or ESCALA PL 850T/R-L+, ESCALA PL 450T/R, ESCALA PL 1650R-L+, 9406-570, ESCALA PL 850R/PL 1650R/R+, ESCALA PL 3250R, ESCALA PL 6450R                           | 1. 42R4855<br>2. 39J5555                             |
| 571E |  | Storage IOA<br>1. Card<br>2. Cache battery pack                                                                                                  | All                                                                                                                                                                                                                                                                                                                                           | 1. 42R5130<br>2. 39J5554                             |
| 571F |  | Combination storage (571F) and auxiliary cache (575B) IOA<br>1. Card<br>2. Cache battery pack<br>3. SCSI jumper cable<br>4. Battery jumper cable | All                                                                                                                                                                                                                                                                                                                                           | 1. 42R5261<br>2. 42R3969<br>3. 42R4226<br>4. 42R4227 |
| 573D |  | RAID enablement card                                                                                                                             | 112/85, ESCALA PL 250R-L+ or ESCALA PL 450R-VL+, ESCALA PL 250T/R+ or ESCALA PL 450T/R-L+, 9405-520, 9406-520, ESCALA PL 250T/R, ESCALA PL 450T/R+ or ESCALA PL 850T/R-L+, 9406-550, ESCALA PL 450T/R, 7/20                                                                                                                                   | 39J5653                                              |
|      |  |                                                                                                                                                  | ESCALA PL 1650R-L+, 9406-570, ESCALA PL 850R/PL 1650R/R+                                                                                                                                                                                                                                                                                      | 39J5652                                              |
|      |  | Cache battery pack                                                                                                                               | All                                                                                                                                                                                                                                                                                                                                           | 44L0313                                              |
| 574F |  | Auxiliary cache adapter<br>1. Card<br>2. Auxiliary cache to SCSI adapter cable (FC 5580, 5581)<br>3. Cache battery pack                          | All                                                                                                                                                                                                                                                                                                                                           | 1. 42R5133<br>2. 42R4053<br>3. 39J5554               |
| 575B |  | Combination storage (571F) and auxiliary cache (575B) IOA<br>1. Card<br>2. Cache battery pack<br>3. SCSI jumper cable<br>4. Battery jumper cable | All                                                                                                                                                                                                                                                                                                                                           | 1. 42R5261<br>2. 42R3969<br>3. 42R4226<br>4. 42R4227 |



## VPD parts

| CCIN | Failing Function Code | Description  | Model, expansion unit, or unit type                                                                          | Part number |
|------|-----------------------|--------------|--------------------------------------------------------------------------------------------------------------|-------------|
| 25A7 |                       | VPD card     | 112/85                                                                                                       | 03N5668     |
| 52AB |                       | VPD card     | ESCALA PL 250T/R+ or ESCALA PL 450T/R-L+                                                                     | 03N6197     |
| 52A1 |                       | VPD card     | ESCALA PL 450T/R+ or ESCALA PL 850T/R-L+, 7/20                                                               | 03N5213     |
| 52A6 |                       | VPD assembly | ESCALA PL 250R-VL or ESCALA PL 450R-XS                                                                       | 03N5086     |
| 528D |                       | VPD card     | ESCALA PL 250R-VL or ESCALA PL 450R-XS, ESCALA PL 450T/R+ or ESCALA PL 850T/R-L+, 9406-550, ESCALA PL 450T/R | 80P3259     |
| 528E |                       | VPD card     | ESCALA PL 1650R-L+, 9406-570, ESCALA PL 850R/PL 1650R/R+                                                     | 03N6018     |
| 528F |                       | VPD card     | 9405-520, 9406-520, ESCALA PL 250T/R                                                                         | 80P3249     |
| 529A |                       | VPD card     | ESCALA PL 6450R                                                                                              | 80P4973     |
| 52A0 |                       | VPD card     | ESCALA PL 250R-L+ or ESCALA PL 450R-VL+, 7/10                                                                | 03N5211     |
| 52A1 |                       | VPD card     | ESCALA PL 450T/R+ or ESCALA PL 850T/R-L+, 7/20                                                               | 03N5213     |
| 52A3 |                       | VPD card     | 185/75                                                                                                       | 03N5161     |
| 52A5 |                       | VPD card     | ESCALA PL 250R-L                                                                                             | 03N5207     |
| 7450 |                       | VPD card     | 9406-520                                                                                                     | 80P3235     |
| 7451 |                       | VPD card     | 9406-520                                                                                                     | 80P3237     |
| 7452 |                       | VPD card     | 9406-520                                                                                                     | 80P3239     |
| 7453 |                       | VPD card     | 9406-520                                                                                                     | 80P3241     |
| 7454 |                       | VPD card     | 9406-520                                                                                                     | 80P3243     |
| 7455 |                       | VPD card     | 9406-520                                                                                                     | 80P3245     |
| 7456 |                       | VPD card     | 9406-520                                                                                                     | 80P3247     |
| 7457 |                       | VPD card     | 9406-520                                                                                                     | 80P3377     |
| 7458 |                       | VPD card     | 9406-520                                                                                                     | 80P3921     |
| 7459 |                       | VPD card     | 9406-520                                                                                                     | 80P4438     |
| 7462 |                       | VPD card     | 9406-550                                                                                                     | 80P3255     |
| 7463 |                       | VPD card     | 9406-550                                                                                                     | 80P3257     |
| 7469 |                       | VPD card     | 9406-570                                                                                                     | 80P4978     |
| 7470 |                       | VPD card     | 9406-570                                                                                                     | 80P3371     |
| 7471 |                       | VPD card     | 9406-570                                                                                                     | 80P5122     |
| 7472 |                       | VPD card     | 9406-570                                                                                                     | 80P5124     |
| 7473 |                       | VPD card     | 9406-570                                                                                                     | 80P5126     |
| 7474 |                       | VPD card     | 9406-570                                                                                                     | 80P5128     |
| 7475 |                       | VPD card     | 9406-570                                                                                                     | 80P5130     |

Service provider information

|      |  |          |          |         |
|------|--|----------|----------|---------|
| 7476 |  | VPD card | 9406-570 | 80P5132 |
| 7488 |  | VPD card | 9406-570 | 80P4982 |
| 7489 |  | VPD card | 9406-570 | 80P4561 |
| 7490 |  | VPD card | 9406-570 | 80P5140 |
| 7491 |  | VPD card | 9406-570 | 80P5142 |
| 7494 |  | VPD card | 9406-570 | 80P5192 |
| 7495 |  | VPD card | 9406-570 | 80P5194 |
| 7496 |  | VPD card | 9406-595 | 80P5680 |
| 7497 |  | VPD card | 9406-595 | 80P5682 |
| 7498 |  | VPD card | 9406-595 | 80P5684 |
| 7499 |  | VPD card | 9406-595 | 80P5686 |
| 7559 |  | VPD card | 9406-570 | 80P5142 |
| 7570 |  | VPD card | 9406-570 | 80P5148 |

OpenPower parts by failing function code

|  | Failing function code | Description                                                                                                                   | Part number        |
|--|-----------------------|-------------------------------------------------------------------------------------------------------------------------------|--------------------|
|  | 451                   | 73.4 GB 15,000 RPM ultra320 SCSI disk drive assembly                                                                          | 03N6347<br>03N5282 |
|  | 453                   | 146.8 GB 10,000 RPM ultra320 SCSI disk drive assembly                                                                         | 03N5267<br>3N63320 |
|  | 542                   | 7208-345 60/150 GB 16-bit 8mm internal tape drive 7334-410 60/150 GB 16-bit 8mm internal tape drive                           | 19P0708<br>19P0207 |
|  | 56D                   | 36.4 GB 15,000 RPM ultra320 SCSI disk drive assembly                                                                          | 03N6342<br>03N5277 |
|  | 57D                   | 73.4 GB 10,000 RPM ultra320 SCSI disk drive assembly                                                                          | 03N5262<br>03N6327 |
|  | 59B                   | 36.4 GB 10,000 RPM ultra320 SCSI disk drive assembly                                                                          | 80P6319            |
|  | 67E                   | POWER GXT135P graphics accelerator with digital support                                                                       | 03N5855            |
|  | 2522                  | PCI-X dual channel ultra 4 320 SCSI adapter                                                                                   | 80P6513            |
|  | 2523                  | PCI-X dual channel ultra320 SCSI RAID adapter                                                                                 | 39J5107            |
|  |                       | Dual channel SCSI RAID enablement card                                                                                        | 80P6517            |
|  | 2529                  | PCI-X dual channel ultra320 SCSI RAID adapter (HV) (FC 1907)<br>PCI-X dual channel ultra320 SCSI RAID adapter (HV1) (FC 1908) | 39J1309<br>39J1985 |
|  | 2530                  | 10/100 Mbps Ethernet PCI adapter II                                                                                           | 80P6508            |
|  | 2531                  | 10 Gigabit Ethernet-LR PCI-X adapter                                                                                          | 03N6972            |

## Service provider information

|  |              |                                                             |                    |
|--|--------------|-------------------------------------------------------------|--------------------|
|  | 2532         | 10 Gigabit Ethernet-SR PCI-X adapter                        | 03N6970            |
|  | 2533         | 10 Gigabit-SR Ethernet PCI-X 2.0 DDR adapter                | 80P7055            |
|  | 2534         | 10 Gigabit-LR Ethernet PCI-X 2.0 DDR adapter                | 80P7053            |
|  | 2535         | 4-port 10/100/1000 base-TX Ethernet PCI-X adapter (FC 1954) | 03N5446            |
|  | 2564<br>2565 | 2-port USB PCI adapter                                      | 80P2994            |
|  | 2566         | External USB 1.44 MB diskette drive                         | 03N4962            |
|  | 2581         | 1 GB iSCSI with TOE Ethernet adapter (copper)               | 30R5209            |
|  | 2583         | 1 GB iSCSI with TOE Ethernet adapter (copper)               | 26K6490            |
|  | 2594         | 4.7 GB IDE slimline DVD-RAM drive                           | 39J1364            |
|  | 2595         | IDE slimline DVD-ROM drive                                  | 03N4712            |
|  | 25B9         | 1 GB iSCSI w/TOE Ethernet adapter (fiber) wrap plug         | 30R5509<br>12R9314 |
|  | 25C0         | Gigabit Ethernet-SX PCI-X adapter                           | 03N698             |
|  | 25C1         | 10/100/1000 base-TX Ethernet PCI-X adapter                  | 03N6525            |
|  | 25C2         | 2-port Gigabit Ethernet-SX PCI-X adapter (fiber)            | 03N6974            |
|  | 25C3         | 2-port 10/100/1000 base-TX Ethernet PCI-X adapter (copper)  | 03N5298            |
|  | 2601         | 2 Gigabit Fibre Channel PCI-X adapter                       | 03N7067            |
|  | 2602         | PCI 64-Bit 4 GB Fibre Channel adapter (1-Port)              | 03N5005            |
|  |              | PCI 64-Bit 4 GB Fibre Channel adapter (1-Port Low Profile)  | 03N5010            |
|  |              | PCI 64-Bit 4 GB Fibre Channel adapter (2-Port)              | 03N5020            |
|  |              | PCI 64-Bit 4 GB Fibre Channel adapter (2-Port Low Profile)  | 03N5025            |
|  | 2611         | 36/72 GB 4 mm internal tape drive                           | 95P1989            |
|  | 2612         | 80/160 GB internal tape drive with VXA2 technology          | 96P1772            |
|  | 2613         | 200/400 GB LTO2 Tape drive                                  | 96P1777            |
|  | 2614         | VXA3 160/320 GB Tape Drive                                  | 95P1977            |

**Instructions for 9348 tape drive**

Is one of the following status codes displayed anywhere on the 9348 control panel? (x = any number)

Exxx  
Fxxx  
\*\*xx  
\*\*\*\*\*

- No: Refer to the 9348 Service Information and use the "Running Diagnostic Tests" procedure to run Diagnostic Test 1. If the test fails, use the 9348 Service Information to determine the failing items.
- Yes: Use the "Status Codes" section of the 9348 Service Information to determine the failing items. For other device types, refer to the device's service information to determine the part number or part numbers that need to be replaced.

**Parent topic:** [Part number catalog](#)

## Part assembly diagrams for 57/86, 57/87, D24, and T24 expansion units

### Cover assemblies

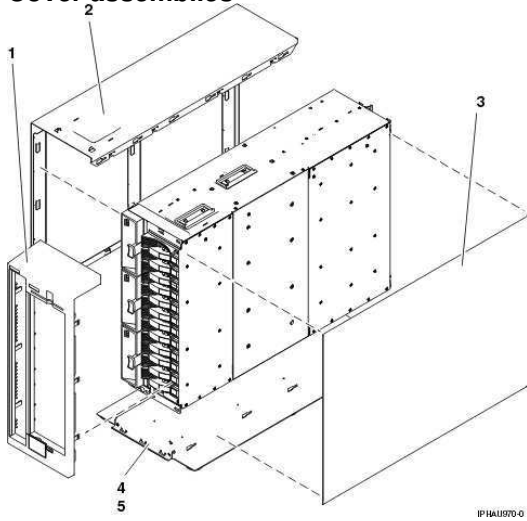


Table 1. Cover assembly part numbers

| Index number | Part number | Units per assembly | Description                      |
|--------------|-------------|--------------------|----------------------------------|
| 1            | 12R8505     | 1                  | Front cover assembly tower       |
| 2            | 12R8373     | 1                  | Side cover assembly tower, left  |
| 3            | 12R8376     | 1                  | Side cover assembly tower, right |
| 4            | 12R8379     | 1                  | Footstand assembly tower         |
| 5            | 12R8382     | 4                  | Screw, M3 x 4 pan head           |

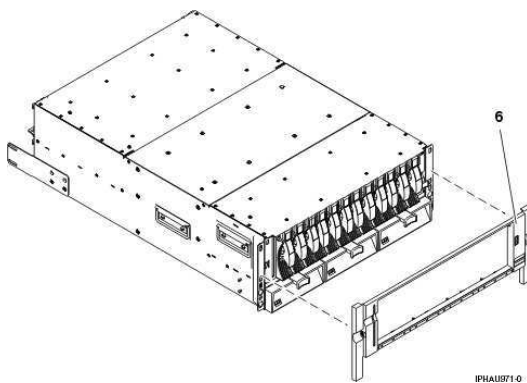


Table 2. Cover assembly part numbers, continued

| Index number | Part number | Units per assembly | Description                    |
|--------------|-------------|--------------------|--------------------------------|
| 6            |             | 1                  | Front cover assembly rack unit |

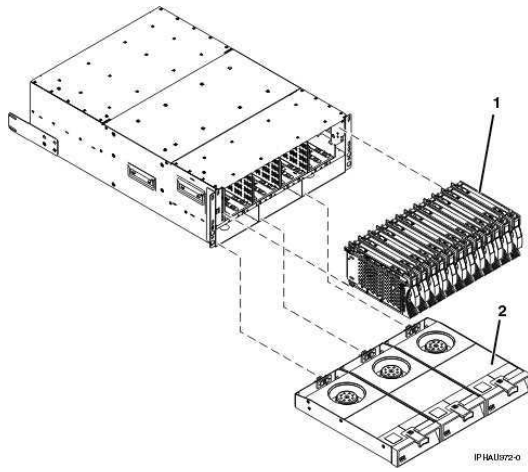


Table 3. Final assembly part numbers

| Index number | Part number                         | Units per assembly | Description                                                                            |
|--------------|-------------------------------------|--------------------|----------------------------------------------------------------------------------------|
| 1            | See <a href="#">Disk unit parts</a> | AR                 | Disk unit assembly                                                                     |
| 1            | 97PJ4179                            | AR                 | Filler assembly disk unit                                                              |
| 2            | 12R9950                             | AR                 | Blower unit assembly                                                                   |
|              | 41V0162                             | 1                  | Chassis assembly FRU (field replaceable unit, includes disk drive backplane) rack unit |
|              | 41V0127                             | 1                  | Chassis assembly FRU (field replaceable unit, includes disk drive backplane) tower     |

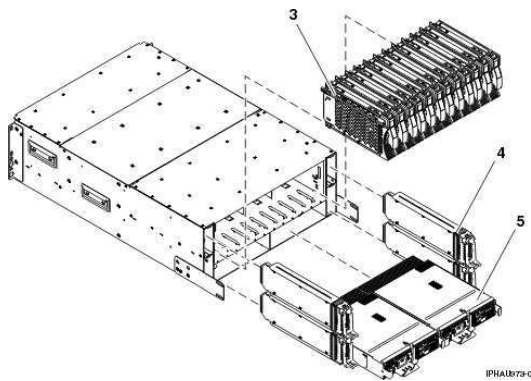


Table 4. Final assembly part numbers, continued

| Index number | Part number                                    | Units per assembly | Description                            |
|--------------|------------------------------------------------|--------------------|----------------------------------------|
| 3            | See <a href="#">Disk unit parts</a>            | AR                 | Disk unit assembly (disk drive)        |
| 3            | 97PJ4179                                       | AR                 | Filler assembly disk unit (disk drive) |
| 4            | See <a href="#">Model D24, T24 backplanes.</a> | AR                 | SCSI repeater card assembly single     |
| 4            | See <a href="#">Model D24, T24 backplanes.</a> | AR                 | SCSI repeater card assembly dual       |
| 4            | 12R7457                                        | AR                 | Filler assembly SCSI repeater card     |

Service provider information

|   |                                   |    |                              |
|---|-----------------------------------|----|------------------------------|
| 5 | See <a href="#">Power parts</a> . | AR | Power supply assembly        |
| 5 | 12R7454                           | AR | Filler assembly power supply |

Parent topic: [Part assembly diagrams](#)

---

## Failing Function Code list

The failing function codes have been migrated into the tables located in [System parts](#). This topic contains the link to the new location.

The Failing Function Code (FFC) table has been removed. The failing function codes have been migrated into the tables located in [System parts](#) along with the CCIN numbers, parts description, model or unit type and part numbers. Using the SRN tables to link to a specific FFC is the fastest way to access your FFC.

---

## Technical publication remarks form

|                                                                                |
|--------------------------------------------------------------------------------|
| <b>Title :</b> ESCALA POWER5 Hardware Information Service provider information |
|--------------------------------------------------------------------------------|

|                                     |
|-------------------------------------|
| <b>Reference N° :</b> 86 A1 19EW 00 |
|-------------------------------------|

|                        |
|------------------------|
| <b>Date:</b> July 2006 |
|------------------------|

### ERRORS IN PUBLICATION

|                                          |
|------------------------------------------|
| <br><br><br><br><br><br><br><br><br><br> |
|------------------------------------------|

### SUGGESTIONS FOR IMPROVEMENT TO PUBLICATION

|                                          |
|------------------------------------------|
| <br><br><br><br><br><br><br><br><br><br> |
|------------------------------------------|

Your comments will be promptly investigated by qualified technical personnel and action will be taken as required.  
If you require a written reply, please include your complete mailing address below.

NAME : \_\_\_\_\_ Date : \_\_\_\_\_

COMPANY : \_\_\_\_\_

ADDRESS : \_\_\_\_\_

Please give this technical publication remarks form to your BULL representative or mail to:

Bull - Documentation Dept.  
1 Rue de Provence  
BP 208  
38432 ECHIROLLES CEDEX  
FRANCE  
info@frec.bull.fr

# Technical publications ordering form

To order additional publications, please fill in a copy of this form and send it via mail to:

**BULL CEDOC**  
**357 AVENUE PATTON**  
**B.P.20845**  
**49008 ANGERS CEDEX 01**  
**FRANCE**

**Phone:** +33 (0) 2 41 73 72 66  
**FAX:** +33 (0) 2 41 73 70 66  
**E-Mail:** [srv.Duplicopy@bull.net](mailto:srv.Duplicopy@bull.net)

| CEDOC Reference #                                                          | Designation | Qty |
|----------------------------------------------------------------------------|-------------|-----|
| -- -- [ ]                                                                  |             |     |
| -- -- [ ]                                                                  |             |     |
| -- -- [ ]                                                                  |             |     |
| -- -- [ ]                                                                  |             |     |
| -- -- [ ]                                                                  |             |     |
| -- -- [ ]                                                                  |             |     |
| -- -- [ ]                                                                  |             |     |
| -- -- [ ]                                                                  |             |     |
| -- -- [ ]                                                                  |             |     |
| -- -- [ ]                                                                  |             |     |
| -- -- [ ]                                                                  |             |     |
| -- -- [ ]                                                                  |             |     |
| -- -- [ ]                                                                  |             |     |
| -- -- [ ]                                                                  |             |     |
| [ ] : The latest revision will be provided if no revision number is given. |             |     |

NAME: \_\_\_\_\_ Date: \_\_\_\_\_

COMPANY: \_\_\_\_\_

ADDRESS: \_\_\_\_\_

PHONE: \_\_\_\_\_ FAX: \_\_\_\_\_

E-MAIL: \_\_\_\_\_

**For Bull Subsidiaries:**

Identification: \_\_\_\_\_

**For Bull Affiliated Customers:**

Customer Code: \_\_\_\_\_

**For Bull Internal Customers:**

Budgetary Section: \_\_\_\_\_

**For Others: Please ask your Bull representative.**





**BULL CEDOC**  
**357 AVENUE PATTON**  
**B.P.20845**  
**49008 ANGERS CEDEX 01**  
**FRANCE**

REFERENCE  
**86 A1 19EW 00**