

bullx blade system

Installation Guide

extreme computing



REFERENCE
86 A1 48 FB 00

extreme computing

bullx blade system

Installation Guide

Hardware

June 2009

BULL CEDOC
357 AVENUE PATTON
B.P.20845
49008 ANGERS CEDEX 01
FRANCE

REFERENCE
86 A1 48 FB 00

The following copyright notice protects this book under Copyright laws which prohibit such actions as, but not limited to, copying, distributing, modifying, and making derivative works.

Copyright © Bull SAS 2009

Printed in France

Trademarks and Acknowledgements

We acknowledge the rights of the proprietors of the trademarks mentioned in this manual.

All brand names and software and hardware product names are subject to trademark and/or patent protection.

Quoting of brand and product names is for information purposes only and does not represent trademark misuse.

The information in this document is subject to change without notice. Bull will not be liable for errors contained herein, or for incidental or consequential damages in connection with the use of this material.

Table of contents

Preface	v
Intended readers	v
Highlighting.....	v
Related publications	v
Legal information	vi
Regulatory declarations and disclaimers	vi
FCC Declaration of conformity	vii
Canadian compliance statement (Industry Canada)	vii
Laser compliance notice.....	viii
Safety information	viii
Definition of safety notices	viii
Electrical safety.....	x
Laser safety information	x
Data integrity and verification	xi
Waste management	xi
Installation flowchart.....	xiii
Chapter 1. Delivery	1
1.1 Introduction	2
1.2 Inspecting the bullx blade system packing	3
1.3 Unpacking the bullx blade system	4
1.3.1 Removing the bullx blade system packing	4
1.4 Checking the bullx blade system	5
Chapter 2. Getting to know the bullx blade system	7
2.1 Overview	8
2.2 What your bullx blade system offers	10
2.3 Reliability, Availability, and Serviceability (RAS)	12
2.4 Features and specifications.....	13
2.4.1 Cabinet specification.....	13
2.4.2 bullx blade chassis-level platform management.....	13
2.4.3 Server-level platform management.....	13
2.4.4 External connections/interfaces	14
2.5 Components, controls, and LEDs	15
2.5.1 Front view	16
2.5.2 Rear view.....	22
Chapter 3. Installing the bullx blade system in the cabinet	33
3.1 bullx blade system cabinet requirements	34
3.2 Preparing the bullx blade chassis rack-mount kit.....	35

3.2.1	Checking the rack-mount kit.....	35
3.2.2	Required tools.....	35
3.3	Installing rack-mount rails in the cabinet	36
3.4	Securing the bullx blade chassis in position	37
Chapter 4.	Connecting and testing the bullx blade system.....	39
4.1	Connecting the bullx blade system to the site power supply	40
4.2	Powering on the bullx blade system for the first time	41
4.3	Checking correct operation.....	42
4.4	Powering off the bullx blade system	43
4.5	Connecting the bullx blade system to the site LAN	44
4.6	Testing LAN connections	46
4.7	Setting up the bullx blade system for remote access via the CHC	47
4.8	Setting up the bullx B500 compute blades for remote access via the BHC	48
Appendix A.	bullx blade system specifications.....	51
Glossary		53
Index		63

List of figures

Figure 1-1.	bullx blade system.....	2
Figure 1-2.	Inspecting the bullx blade system packing	3
Figure 2-1.	User label	9
Figure 2-2.	Major bullx blade system components.....	15
Figure 2-3.	Front view.....	16
Figure 2-4.	bullx B500 compute blade (18 in total).....	17
Figure 2-5.	bullx B500 compute blade	17
Figure 2-6.	Fan blades.....	20
Figure 2-7.	Local Control Panel	21
Figure 2-8.	Rear view	22
Figure 2-9.	Power Supply Unit	23
Figure 2-10.	Chassis Management Module.....	25
Figure 2-11.	Quad Switch Module	27
Figure 2-12.	Ultra Capacitor Module	28
Figure 2-13.	Ethernet Switch Module	30
Figure 3-1.	Recommended position of bullx blade system.....	34
Figure 3-2.	Installing rack-mounted rail in cabinet	36
Figure 3-3.	Securing the bullx blade chassis in the cabinet.....	37
Figure 4-1.	Connecting the bullx blade system to the site LAN	44
Figure 4-2.	Chassis Hardware Console page	47
Figure 4-3.	Blade Hardware Console page.....	49

List of tables

Table 2-1.	Record information.....	8
Table 3-1.	Rack-mount kit items	35

Preface

This guide explains how to install your bullx blade system.

Note The Bull Support Web site may be consulted for product information, documentation, downloads, updates, and service offers:
<http://support.bull.com>

Intended readers

This guide is intended for use by qualified support personnel.

Highlighting

The following highlighting conventions are used in this guide:

Bold	Identifies the following: <ul style="list-style-type: none">• Interface objects such as menu names, labels, buttons and icons• File directory and path names• Keywords to which particular attention must be paid
<i>Italics</i>	Identifies references such as manuals or URLs

Related publications

- *bullx blade system Maintenance and Troubleshooting Guide, 86 A7 51FB 00* explains how to maintain, service, and upgrade the bullx blade system. This guide is intended for use by qualified support personnel
- *bullx blade chassis User's Guide, 86 A1 50FB 00* explains how to use the bullx blade chassis. This guide is intended for use by Customer Administrators and Operators
- *bullx B500 compute blade User's Guide, 86 A1 49FB 00* explains how to use the bullx B500 compute blade. This guide is intended for use by Customer Administrators and Operators

Legal information

Regulatory declarations and disclaimers

Declaration of the manufacturer or importer

We hereby certify that this product is in compliance with:

- European Union EMC Directive 2004/108/EC, using standards EN55022 (Class A) and EN55024 and Low Voltage Directive 2006/95/EC, using standard EN60950
- International Directive IEC 60297 and US ANSI Directive EIA-310-E

Safety compliance statement

- UL 60950-1 USA
- EC 60950-1 international
- CSA 60950-1 Canada

European Community (EC) Council directives

This product is in conformity with the protection requirements of the following EC Council Directives:

Electromagnetic compatibility

- 2004/108/EC

Low voltage

- 2006/95/EC

EC conformity

- 93/68/EEC

Telecommunications terminal equipment

- 1999/5/EC

Neither the provider nor the manufacturer can accept responsibility for any failure to satisfy the protection requirements resulting from a non-recommended modification of the product.

Compliance with these directives requires:

- An EC declaration of conformity from the manufacturer
- An EC label on the product
- Technical documentation

Mechanical structures

- IEC 60297
- EIA-310-E

FCC Declaration of conformity

This device complies with Part 15 of the FCC Rules. Operation is subject to the following two conditions: (1) this device may not cause harmful interference, and (2) this device must accept any interference received, including interference that may cause undesired operation.

Federal Communications Commission (FCC) Statement

This equipment has been tested and found to comply with the limits for a Class A digital device, pursuant to Part 15 of the FCC Rules. These limits are designed to provide reasonable protection against harmful interference when the equipment is operated in a commercial environment. This equipment generates, uses, and can radiate radio frequency energy and, if not installed and used in accordance with the instruction manual, may cause harmful interference to radio communications. Operation of this equipment in a residential area is likely to cause harmful interference in which case the user will be required to correct the interference at his own expense.

Properly shielded and grounded cables and connectors must be used in order to meet FCC emission limits. Neither the provider nor the manufacturer is responsible for any radio or television interference caused by using other than recommended cables and connectors or by unauthorized changes or modifications to this equipment. Unauthorized changes or modifications could void the user's authority to operate the equipment.

Pursuant to Part 15.21 of the FCC Rules, any changes or modifications to this equipment not expressly approved by Bull SAS may cause harmful interference and void the FCC authorization to operate this equipment.

An FCC regulatory label is affixed to the equipment.

Canadian compliance statement (Industry Canada)

This Class A digital apparatus meets all requirements of the Canadian Interference Causing Equipment Regulations.

Cet appareil numérique de la classe A est conforme à la norme NMB-003 du Canada.

This product is in conformity with the protection requirements of the following standards:

- ICES-003
- NMB-003

Laser compliance notice

This product that uses laser technology complies with Class 1 laser requirements.

A CLASS 1 LASER PRODUCT label is affixed to the laser device.

<p>Class 1 Laser Product Luokan 1 Laserlaite Klasse 1 Laser Apparat Laser Klasse 1</p>
--

Safety information

For Your Safety, this manual contains important information, required to operate the server safely. Thoroughly review the information in this manual before using the server.

Use the following safety guidelines to ensure your personal safety and to help protect your server from potential damage. Throughout this guide, blocks of text may be accompanied by an icon which needs to be followed for your safety.

Definition of safety notices



DANGER

A Danger notice indicates the presence of a hazard that has the potential of causing death or serious personal injury.



CAUTION

A Caution notice indicates an action that could cause damage to a program, device, system, or data. A Caution notice may also indicate the presence of a hazard that has the potential of causing moderate or minor personal injury.

Read the installation instructions before connecting the system to the power source. Hazardous current and energy levels are present in areas indicated by this label. There are no serviceable parts inside these components. If you suspect a problem with one of these parts, contact service technician.



CAUTION

This unit is intended for installation in restricted access areas. A restricted access area can be accessed only through the use of a special tool, lock and key or other means of security. Only trained and qualified personnel should be allowed to install, replace, or service this equipment.

- This equipment must be grounded. Contact the appropriate electrical inspection authority or an electrician if you are uncertain that suitable grounding is available
- Do not overload the AC supply branch circuit that provides power to the rack. The total rack load should not exceed 80 percent of the branch circuit rating

- Use only power cables that are approved for use in the respective country. The power cable must be rated for the product and for the voltage and current marked on the product's electrical ratings label. The voltage and current rating of the cable should be greater than the ratings marked on the product
- If any of the following conditions occur, unplug the equipment from the electrical outlet and replace the part or contact your trained service technician:
 - The power cable, extension cable, or plug is damaged
 - An object has fallen into the equipment
 - The equipment has been exposed to water
 - The equipment does not operate correctly when you follow the operating instructions
- Allow the equipment to cool before removing covers or touching internal components
- Suitable disconnect device must be provided as part of the building installation. The purpose of the disconnect device is to provide an easy and accessible means for removing power from the product for servicing
- Opening or removing covers that are marked with the triangle symbol with a caution mark may expose you to risk of electrical shock. Components inside these compartments should be serviced only by a trained service technician
- Ensure that the voltage and frequency of your power source match the voltage and frequency inscribed on the equipment's electrical rating label
- Hazardous energy is present when the blade is connected to the power source. Always replace the blade cover before installing the blade
- When removing the bullx B500 compute blade/power supply, dummy bullx B500 compute blade, filler covers, do not insert your hand into the open slots. Doing so may cause electric shock
- Do not operate your equipment with any filler covers removed
- Do not push any objects into the openings of your system components. Doing so can cause fire or electric shock by shorting out interior components
- Do not use top blade handle to lift the bullx blade chassis. These are used only to install and remove the blade only
- Do not restrict airflow into the equipment by blocking any vents or air intakes
- Cleaning: Unplug your system from wall outlet before cleaning
- Do not spill food or liquids on your system components. Never operate the product in a wet environment



CAUTION

When connecting or disconnecting power to hot-pluggable power supplies observe the following guidelines:

- **Install the power supply before connecting the power cable to the power supply**
- **Unplug the power cable before removing the power supply**

- If the equipment has multiple sources of power, disconnect power from the system by unplugging all power cables from the power supplies to reduce shock hazard
- Never open the power supply module for any reason
- The power supplies in your system may produce high voltages and energy hazards. Only trained service technicians are authorized to remove the covers and access any of the components inside the system



CAUTION

Incorrectly installing a battery or using an incompatible battery may increase the risk of fire or explosion. Replace the battery only with the same or equivalent type recommended by the manufacturer, carefully following installation instructions. Dispose of used batteries properly. Handle batteries carefully. Do not disassemble, crush, or puncture batteries.

Electrical safety



DANGER

The Customer is responsible for ensuring that the AC electricity supply is compliant with national and local recommendations, regulations, standards and codes of practice. An incorrectly wired and grounded electrical outlet may place hazardous voltage on metal parts of the system or the devices that attach to the system and result in an electrical shock. It is mandatory to remove power cables from electrical outlets before relocating the system.



CAUTION

This unit has more than one power supply cable. Follow procedures for removal of power from the system when directed.

Laser safety information

The optical drive in this system unit is classified as a Class 1 level Laser product. The optical drive has a label that identifies its classification.

The optical drive in this system unit is certified in the U.S. to conform to the requirements of the Department of Health and Human Services 21 Code of Federal Regulations (DHHS 21 CFR) Subchapter J for Class 1 laser products. Elsewhere, the drive is certified to conform to the requirements of the International Electro technical Commission (IEC) 60825-1: 2001 and CENELEC EN 60825-1: 1994 for Class 1 laser products.



CAUTION

Invisible laser radiation when open. Do not stare into beam or view directly with optical instruments.

Class 1 Laser products are not considered to be hazardous. The optical drive contains internally a Class 3B gallium-arsenide laser that is nominally 30 milliwatts at 830 nanometers. The design incorporates a combination of enclosures, electronics, and redundant interlocks such that there is no exposure to laser radiation above a Class 1 level during normal operation, user maintenance, or servicing conditions.

Data integrity and verification



CAUTION

Bull products are designed to reduce the risk of undetected data corruption or loss. However, if unplanned outages or system failures occur, users are strongly advised to check the accuracy of the operations performed and the data saved or transmitted by the system at the time of outage or failure.

Waste management

This product has been built to comply with the Restriction of Certain Hazardous Substances (RoHS) Directive 2002/95/EC.

This product has been built to comply with the Waste Electrical and Electronic (WEEE) Directive 2002/96/EC.

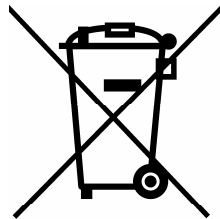

Installation flowchart

Step	Installation process	Remarks	Pointers in guide
1	Unpacking the bullx blade system	Inspect the bullx blade system packing, unpack and unload, and store packing items.	Chapter 1
2	Installing the bullx blade system in the cabinet	Fix the rack mount brackets and shipping brackets, push the bullx blade system into the cabinet and secure it with screws.	Chapter 3
3	Powering the bullx blade system		Section 4.2
4	Connecting the bullx blade system to the LAN	Connect the bullx blade system to the site LAN and test network connections.	Section 4.5
5	Setting up the bullx blade system	Configure the bullx blade system for remote management.	Sections 4.7 and 4.8

Chapter 1. Delivery

This chapter explains delivery, unpacking, and inspection for the bullx blade system.

1.1 Introduction

The bullx blade system is a high-density and high-performance rack-mounted server system developed for medium-to-large businesses. The bullx blade system is delivered in a box that contains all the data and items required for installation.

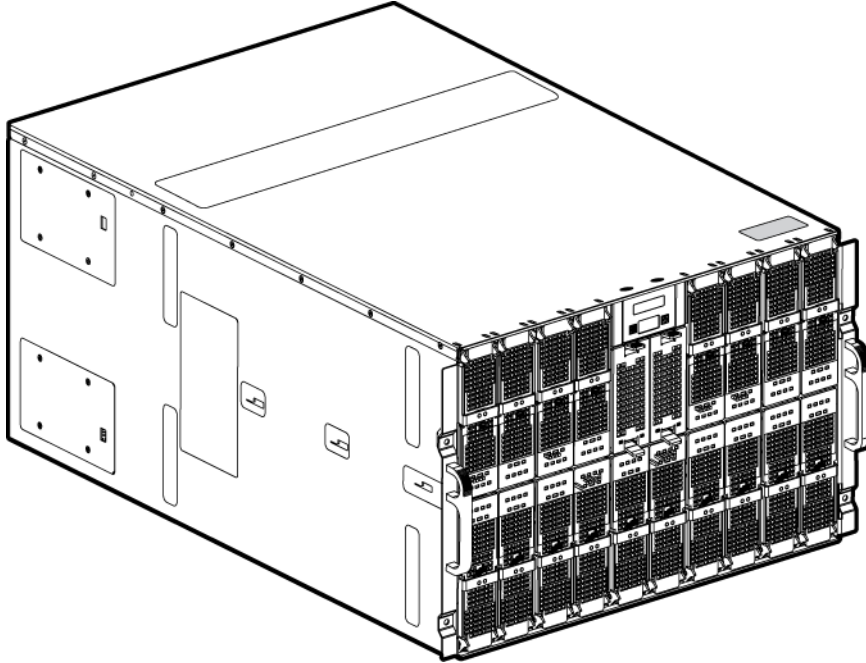

Figure 1-1. bullx blade system



CAUTION

It is mandatory for the bullx blade system to be transported vertically.

1.2 Inspecting the bullx blade system packing

Before unpacking, inspect the bullx blade system packing to check its condition:

- Check for any damages or any visible defects on the packaged bullx blade system
- Shockwatch label should be in white color, which indicates that the package has not faced any impact or thrust force during transit
- Tiltwatch label should not be in red
- Note the indicator status on the bill of lading and carefully inspect the bullx blade system before powering up

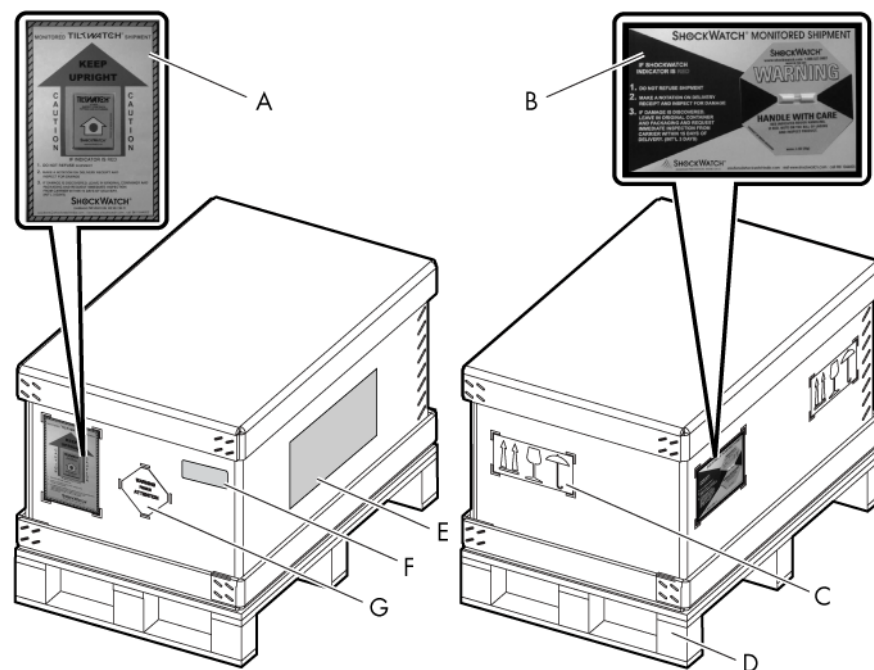

Figure 1-2. Inspecting the bullx blade system packing

- A. Tiltwatch
- B. Shockwatch
- C. Safety label
- D. Wooden stand
- E. Packing lists
- F. Product label
- G. Warning label

1.3 Unpacking the bullx blade system

After ensuring that the bullx blade system package is devoid of damages, you have to unpack and store it in a proper place.



DANGER

Authorized service personnel only may unpack and physically install the bullx blade system.

1.3.1 Removing the bullx blade system packing



CAUTION

To avoid personnel injury, before lifting the bullx blade system, remove all the bullx B500 compute blades to reduce the weight.

The following steps help you to remove the packing:

1. Cut the straps covering the package.
2. Remove the top corrugated cover.
The inner foam is now visible and it contains another small package that has a rack-mounting kit and shipping bracket assembly that are needed to place the bullx blade system on a Bull Cabinet.
3. Remove the small package and take out this top foam.
There will be another corrugated sleeve covering the bullx blade system from outside.
4. Hold the sleeve and lift it up.
5. Remove the inner foams at different ends.
6. Move the bullx blade system to a required place, like a Bull Cabinet, through suitable lifting equipment.



Store the package material in a safe and clean place for possible future use.

1.4 Checking the bullx blade system

Perform a preliminary visual inspection after unpacking the bullx blade system. The following list helps in your inspection:

- Check that the bullx blade system delivered is compliant with the Purchase Order
- Check for internal damage, alterations and obvious safety hazards, such as broken wires, sharp edges, or broken insulation
- Check internal cables for damage



CAUTION

If the inspection indicates an unacceptable safety condition, the condition must be corrected before powering up the bullx blade system.

Chapter 2. Getting to know the bullx blade system

This chapter gives an overview at the bullx blade system-level architecture and a high-level description of each of these modules.

2.1 Overview

Your bullx blade system is a high-density server system providing cluster architecture. It has 18 bullx B500 compute blade bays, making it ideally suited for High Performance Computing (HPC) cluster environment that requires a large number of high-performance servers in a small space. The bullx blade system provides common resources that are shared by the bullx B500 compute blades, such as power, cooling, system management, network connections, and I/O switch. The use of common resources reduces the size of the bullx B500 compute blades, minimizes cabling, and also reduces the time/likelihood of idle resources.

Performance, ease of use, reliability, and expansion capabilities were key considerations during the design of the bullx blade system. These design features make it possible for you to customize the system hardware to meet your needs today, while providing flexible expansion capabilities for the future.

This guide provides information on:

- Installing the bullx blade system
- Connecting and testing the bullx blade system

This bullx blade system *Installation Guide* and other publications that provide detailed information about your bullx blade chassis are provided in Portable Document Format (PDF) on the *bullx blade chassis Documentation and Resource CD*.

Record information about your bullx blade system in the following table:

	bullx blade system
Product Name	
Product Code	
Product Number	
Serial Number	

Table 2-1. Record information

The serial number and part number are on a label on the top of the bullx blade chassis, as shown in the following illustration.

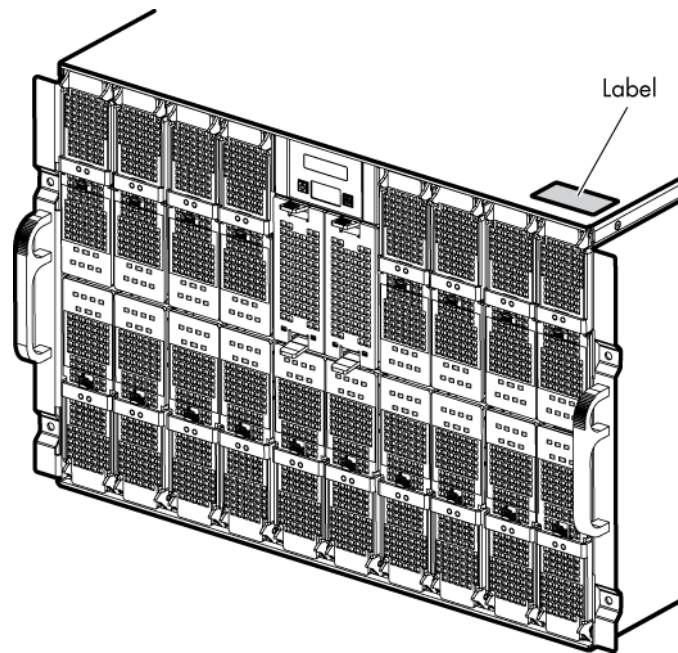

Figure 2-1. User label

Six bullx blade systems can be simultaneously housed in a 42U cabinet. The bullx blade system houses the following key hardware components, some of which are optional:

- Eighteen dual processor (DP) bullx B500 compute blades, called Nehalem CPU blade (NCB). Each NCB includes two fans for cooling
- A Quad Switch Module
- Provision for an optional Ultra Capacitor Module (UCM)
- A Chassis Management Module (CMM)
- An optional Ethernet Switch Module (ESM)
- Front panel module Local Control Panel (LCP) providing a LCD display power button and reset button
- Up to four Power Supply Unit modules (PSU) providing N+1 redundancy on power
- Two Fan blades in the front of the bullx blade chassis, to provide cooling to the Quad Switch Module, CMM, and ESM

2.2 What your bullx blade system offers

The design of your bullx blade system takes advantage of advancements in server technology. It hosts up to 18 functionally separate bullx B500 compute blades and their shared resources in a single bullx blade chassis. Your bullx blade system combines:

Innovative technology

Proven innovative technologies to build powerful, scalable and reliable Intel®-processor-based servers.

Expansion capabilities

You can add bullx B500 compute blades to the bullx blade system as needed and it can host a maximum of 18 blades.

Hot-swap/Hot-plug capabilities

The front bays on the bullx blade system are hot-plug blade bays. The rear switch and management bays on the bullx blade system are hot-plug module bays. You can add, remove or replace bullx B500 compute blades, CMM in hot-plug bays without removing power from the bullx blade system by first ensuring the module is not in use by the system, which means that no active software or applications are running. The rear power supply bays on the bullx blade system are also hot-swappable. You can add, remove or replace the power or Fan blades from the bullx blade system without powering off the bullx blade system.



CAUTION

To maintain proper system cooling; each unoccupied bay must contain a filler blade or filler module.

Redundancy capabilities

The redundant components in the front and in the rear of your bullx blade system enable continued operation even if a component fails.

PSU modules and Fan blades: Normally, the redundant PSU modules and Fan blades share the load. If one of the power modules or Fan blades fails, the non-failing power module or Fan blade handles the entire load. You can then replace the failed Fan blades or power module without shutting down the bullx B500 compute blade.

Redundant network connection capabilities

The optional ESM provides redundant Ethernet interface to the blades.

System management capabilities

Your bullx blade system comes with a service processor in the CMM. This service processor, in conjunction with the system-management firmware that is provided with the service processor in each bullx B500 compute blade, enables you to remotely manage the bullx blade system components, and the bullx B500 compute blades. The CMM also multiplexes the USB, keyboard, mouse, and video ports across the multiple bullx B500 compute blades.

The service processor in each bullx B500 compute blade provides bullx B500 compute blade system monitoring, event recording, and alert capability.

Network environment support

Your bullx blade system supports up to two Ethernet Switches: One in the CMM and the second one in the ESM. These Ethernet Switch Modules can be used for bullx B500 compute blade communication with the network. Each CMM/ESM provides an internal connection to each bullx B500 compute blade and up to 18 internal connections.

2.3 Reliability, Availability, and Serviceability (RAS)

Three of the most important features in server design are reliability, availability, and serviceability (RAS). These factors help to ensure the integrity of the data stored on your bullx B500 compute blade; that your bullx B500 compute blade is available when you want to use it; and that should a failure occur you can easily diagnose and repair the failure with minimal inconvenience.

The following is a list of RAS features that your bullx blade system supports:

- Shared key components, such as power, cooling, and I/O
- All components serviced from the front or rear of the bullx blade chassis
- Built-in monitoring for Fan blade, power, temperature, and voltage
- Built-in monitoring for module redundancy
- Error codes and messages
- Fault-resistant startup
- Remote system management through the CMM
- Remote CMM firmware upgrade
- Remote upgrade of bullx B500 compute blade service processor microcode
- Redundant components:
 - Cooling fans blades (blowers)
 - Power Supply Unit Modules
- Hot-plug components:
 - bullx B500 compute blades
 - Chassis Management Module
 - Ethernet Switch Module
 - Quad Switch Module
 - Power Supply Unit module
- Non Hot-swappable components: Ultra Capacitor Module

2.4 Features and specifications

Following is a summary of the features and specifications for your bullx blade system:

- The bullx blade system, 18 server, 7U Chassis, rack-able within a standard 19 cabinet includes front panel, power supplies and Midplane
- Dual CPU socket bullx B500 compute blades using the EP family of Xeon processors from Intel®
- Module height 307 mm maximum
- Width 446 mm maximum
- Depth 740 mm
- Weight up to 125 kg depending on the system configuration
- Typical power consumption is about 8000 W
- AC power modules offer N+1 redundancy
- Maximum number of power modules with/without redundancy: 4/3
- Two Fan blades in front, cooling the Quad Switch Module, CMM and ESM
- LCP display in front

2.4.1 Cabinet specification

- Rack mounted system, using a standard cabinet
- 480mm (19") wide
- 740mm deep chassis

2.4.2 bullx blade chassis-level platform management

- Embedded web server
- Supports both Microsoft Internet Explorer and Firefox browsers
- SNMP, SMASH/CLP, and IPMI Out of Band compliant interface
- Logistic control (thermal, cooling, global power control, and power distribution)
- Hardware health monitoring and alerting

2.4.3 Server-level platform management

- Embedded web server
- Supports both Microsoft Internet Explorer and Firefox browsers
- IPMI v2.0, SMASH/CLP Out of Band compliant interface
- Logistic control (thermal, local power control, and power distribution)
- Hardware health monitoring and alerting

2.4.4 External connections/interfaces

Following are external connections available in the bullx blade system:

- Eighteen IB QDR connections (QSFP connector with power) on the Quad Switch Module
- Three 1Gb Ethernet ports -RJ45 connectors on the ESM
- Three 1Gb Ethernet ports -RJ45 connectors and a serial COM port for maintenance purpose are present on the CMM
- There is a control panel on the front of the bullx blade chassis
- bullx blade chassis power On/Off switch
- bullx blade chassis power indicator LED
- bullx blade chassis indicator blue LEDs – LCP indicator LED, CMM indicator LED at the rear
- bullx B500 compute blade indicator LEDs
- Quad Switch Module indicator LED
- Gbit Ethernet switch indicator LED
- Ultra Capacitor Module indicator LED
- CMM reset push button to reset Chassis Management Controller (CMC)

2.5 Components, controls, and LEDs

This section identifies the components, controls, and LEDs on the front and rear of your bullx blade system.

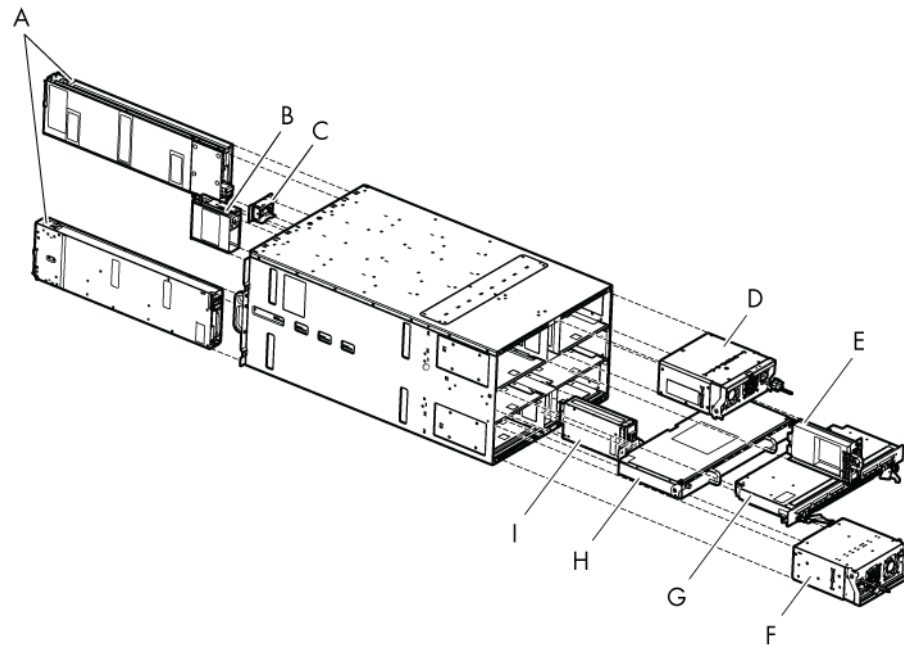

Figure 2-2. Major bullx blade system components

- A. bullx B500 compute blades
- B. Fan blade
- C. Local Control Panel
- D. Power Supply Unit module
- E. Chassis Management Module
- F. Power Supply Unit module
- G. Quad Switch Module
- H. Ultra Capacitor Module
- I. Ethernet Switch Module

Note The illustrations in this document might differ slightly from your hardware.

2.5.1 Front view

This section identifies the components, controls, and LEDs on front of your bullx blade system.

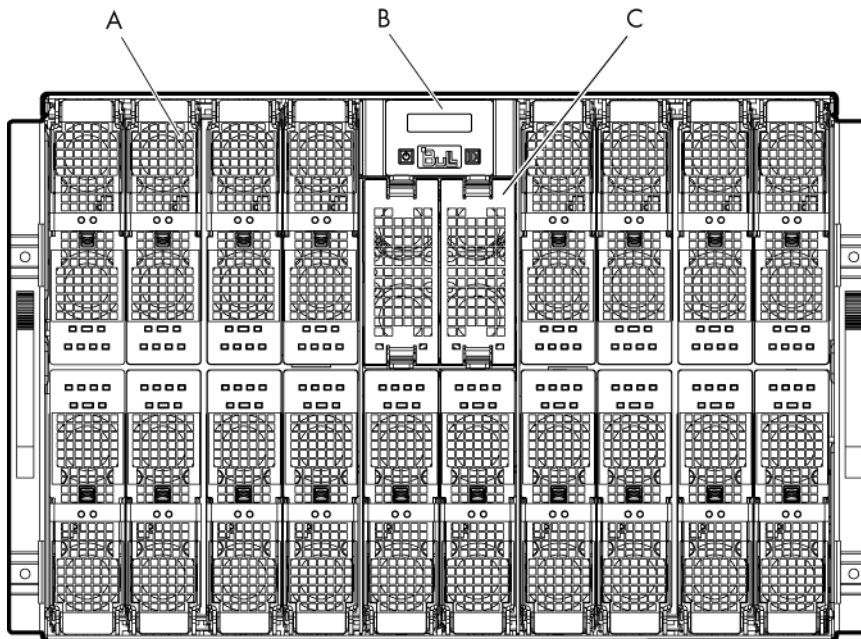

Figure 2-3. Front view

- A. bullx B500 compute blade
- B. Local Control Panel
- C. Fan blade

2.5.1.1 bullx blade chassis

In the front side, the bullx blade chassis has a LCP, 18 bays to host bullx B500 compute blades and two bays to host fan blades. The bullx blade chassis includes two handles that help in moving the bullx blade chassis. The Midplane, in the middle of the bullx blade chassis, provides interconnectivity among blades and the various modules located in the rear of the bullx blade chassis.

2.5.1.2 bullx B500 compute blades

The 18 bullx B500 compute blades are distributed in two rows, with eight on top row and 10 on the bottom row. All the blades are inserted from the front of the bullx blade system and plugged vertically into the Midplane.

The bullx B500 compute blade provides the server motherboard functionality based on dual Nehalem-EP (Efficient Performance) processors from Intel®. The processor features a quad-core processing to maximize performance and performance/watt for datacenter infrastructures and highly dense deployments. Each Nehalem-EP processor interconnects with the other Nehalem-EP processor and the Tylersburg north bridge through the Intel's Quick Path Interconnect (QPI) feature. Each bullx B500 compute blade interconnects with

other bullx B500 compute blades through an embedded ConnectX QDR component and the Quad Switch Module.

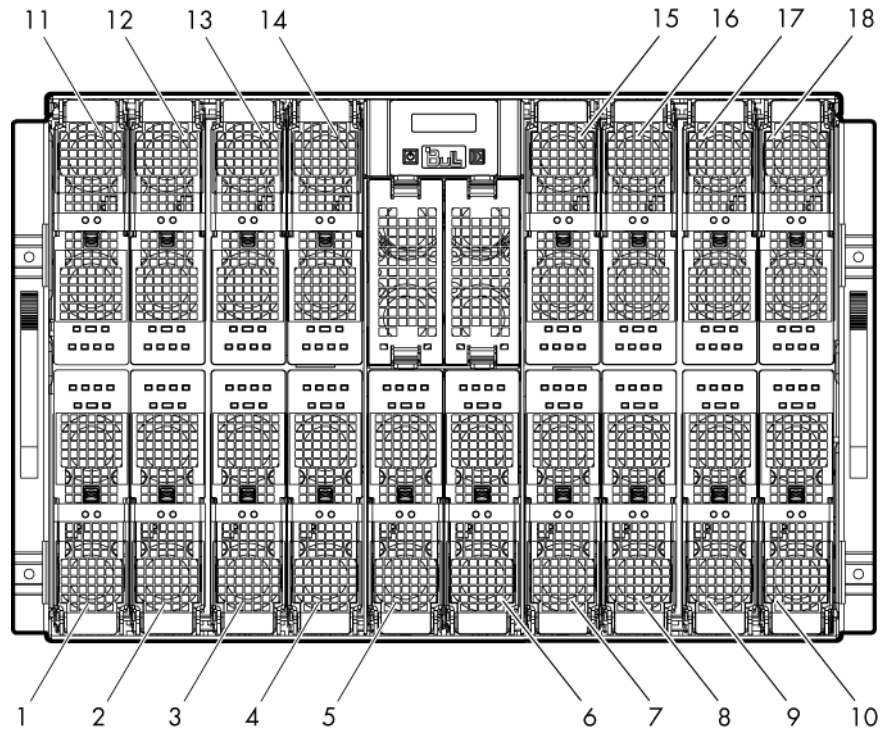

Figure 2-4. bullx B500 compute blade (18 in total)

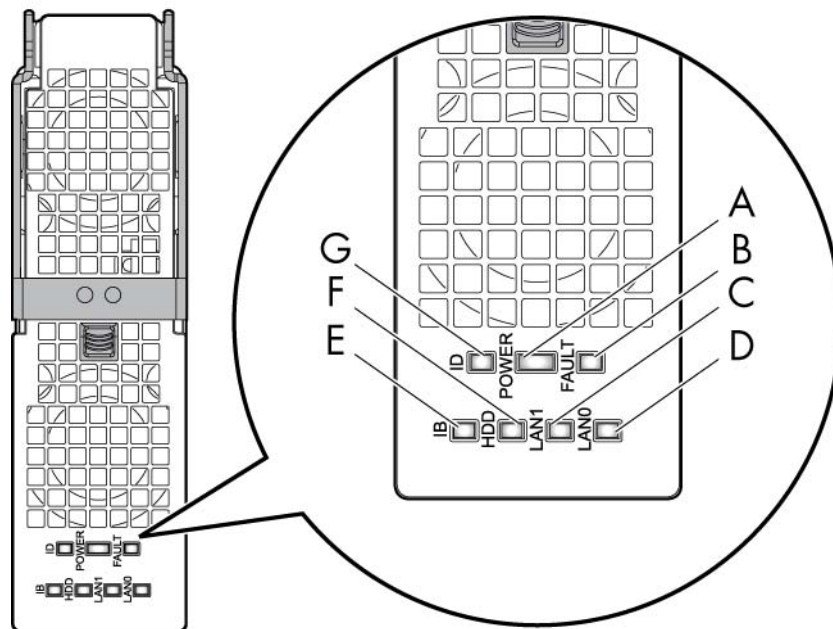

Figure 2-5. bullx B500 compute blade

- A. Power LED
- B. Fault LED
- C. LAN1 LED

- D. LAN0 LED
- E. IB activity LED
- F. HDD activity LED
- G. Identification LED

2.5.1.3 bullx B500 compute blade specific features

The other bullx B500 compute blade features are:

- Powered down bullx B500 compute blades can be inserted and removed without disturbing operations
- Two processor sockets
- Up to two Nehalem-EP processor
- All processor SKUs supported up to 95W
- Double Data Rate 3 at 1333 or 1066 MHz
- Twelve DIMM slots (6 per socket)
- Only one DIMM per channel is supported for DDR3 1333MHz (3 per socket)
- hot plugging is supported
- No PCI Express slots
- Optional SATA drive (HDD or SSD) form factor 1.8 inch
- Sleep state four (Suspend to disk) supported on HDD/SSD when available
- LEDs in front for status indication

LED indicators

- **Identification LED**

The identification LED indicator is blue.

This indicator is a unit identifier dedicated to the maintenance operations to localize physically a bullx B500 compute blade.

The switching On/Off of this indicator is driven by the maintenance operator through the Chassis Hardware Console web interface.

- **Power LED**

The power LED indicator is bicolor: amber/green.

This indicator provides the bullx B500 compute blade power state:

- Amber: 3.3V stand-by power presence (the blade is in stand by mode)
- Green: 12V main power presence

This indicator is managed by the hardware.

- **Fault LED**

The fault LED indicator is red.

This indicator allows display fault detected by the integrated Baseboard Management Controller (iBMC) firmware.

This indicator is managed by the iBMC firmware.

- **LAN 0 activity LED**

The LAN 0 activity LED indicator is blinking green.

This indicator flashes On and Off to indicate traffic (Tx and Rx data) on the Ethernet network channel 0 (to/from CMM) for this bullx B500 compute blade.

- **LAN 1 activity LED**

The LAN 1 activity LED indicator is blinking green.

This indicator flashes On and Off to indicate traffic (Tx and Rx data) over the Ethernet network channel 1 (to/from ESM) for this bullx B500 compute blade through the Ethernet component.

This indicator is managed by the hardware.

- **IB activity LED**

The IB activity LED indicator is blinking amber

This indicator flashes On and Off to indicate traffic over the IB network channel 0 for this bullx B500 compute blade (through the ConnectX component).

This indicator is managed by the hardware

- **HDD activity LED**

The HDD activity LED indicator is blinking amber

This indicator flashes On and Off to indicate traffic over the SATA link.

This indicator is managed by the hardware.



DANGER

Hazardous energy is present when the bullx B500 compute blade is connected to the power source. Always replace the blade cover before inserting the blades into the bullx blade chassis.

2.5.1.4 Fan blade

Two Fan blades provide cooling to the Quad Switch Module, CMM, and ESM. Fan blades cannot be hot swapped.



Important

Replace a failed Fan blade as soon as possible to restore cooling redundancy. See the *bullx blade system Maintenance and Troubleshooting Guide* on the *bullx blade system Resource and Documentation CD* for instructions.

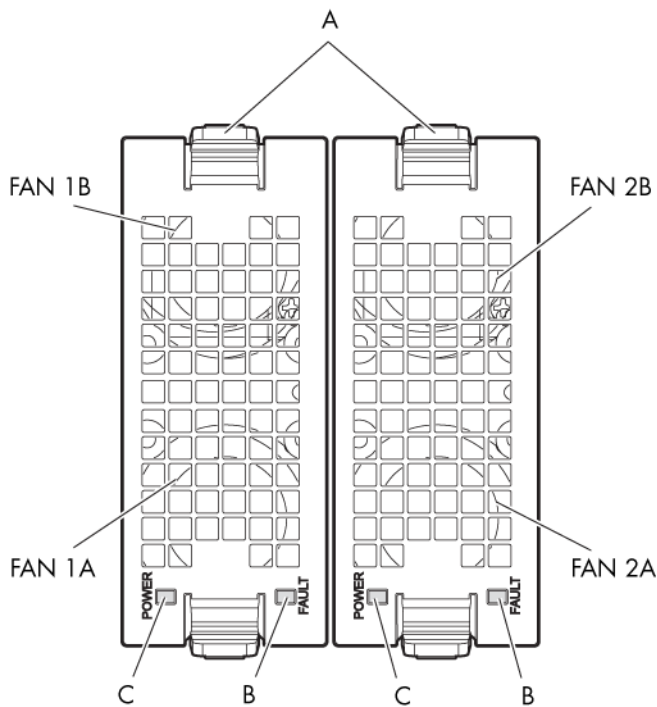

Figure 2-6. Fan blades

- A. Latch
- B. Fault LED
- C. Power LED

LED indicators

- **Fault LED**
When the fans do not rotate as per the expected speed, the fault LED switches On:
Red.
- **Power LED**
When the Fans are rotating as per the expected speed, the power LED switches On.

2.5.1.5 Local Control Panel

The Local Control Panel (LCP) is the panel related to the bullx blade chassis. This panel is placed in the center of the bullx blade chassis.

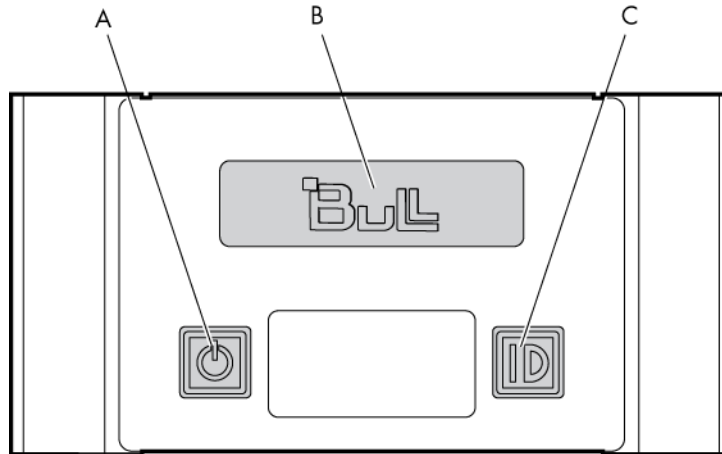

Figure 2-7. Local Control Panel

- A. Power On/Off button
- B. Display screen
- C. Identification button

LED indicators

- **Identification LED**

The identification LED indicator is blue.

This indicator is a unit identifier dedicated to the maintenance operations to localize physically a bullx blade chassis from the front side. This LED is turned On simultaneously with the CMM identification LED indicator for the backside.

The switching On/Off of this indicator is driven by the maintenance operator through the CMC or locally through the identification button of the LCP.

- **Power LED**

The power LED indicator is green.

This indicator indicates the 12V main power presence within the bullx blade chassis. This indicator is managed by the CMC firmware.

2.5.2 Rear view

This section identifies the components and indicators on the rear of your bullx blade system.

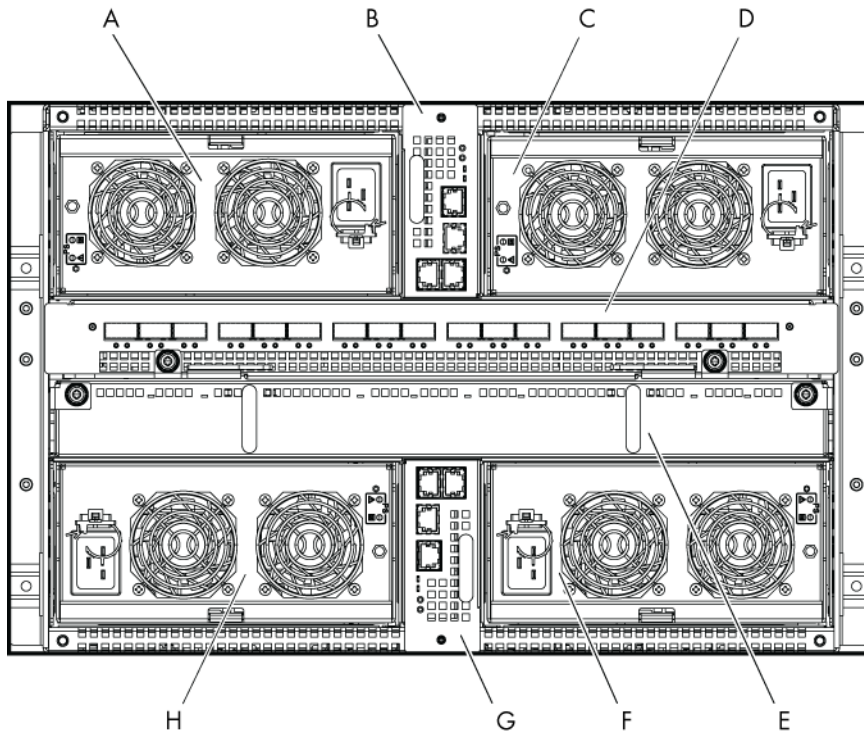

Figure 2-8. Rear view

- A. PSU3
- B. CMM
- C. PSU4
- D. Quad Switch Module
- E. UCM
- F. PSU2
- G. ESM
- H. PSU1

2.5.2.1 bullx blade chassis

The rear side of the bullx blade chassis provides bays for bullx blade system PSUs, CMM, Quad Switch Module, UCM, and the ESM modules.

2.5.2.2 Power Supply Unit module

There are four PSU modules in the bullx blade system, each of 2900W rating. These take in the AC input of 180VAC to 264VAC and provide 12V main and 3.3V standby outputs. The four PSU modules provide N+1 redundancy. The typical system power dissipation is around 7900W depending on the configuration and the customer's applications. The PSU modules occupy the rear of the bullx blade system.

The high-level features of the PSU module are as below:

- Power Supply 2900 W
- Has two outputs including 12V and a 3.3V stand-by
- AC input power factor corrected
- Hot swappable, up to four parallel supplies
- AC input of 180 to 264V AC
- PSMI compliant

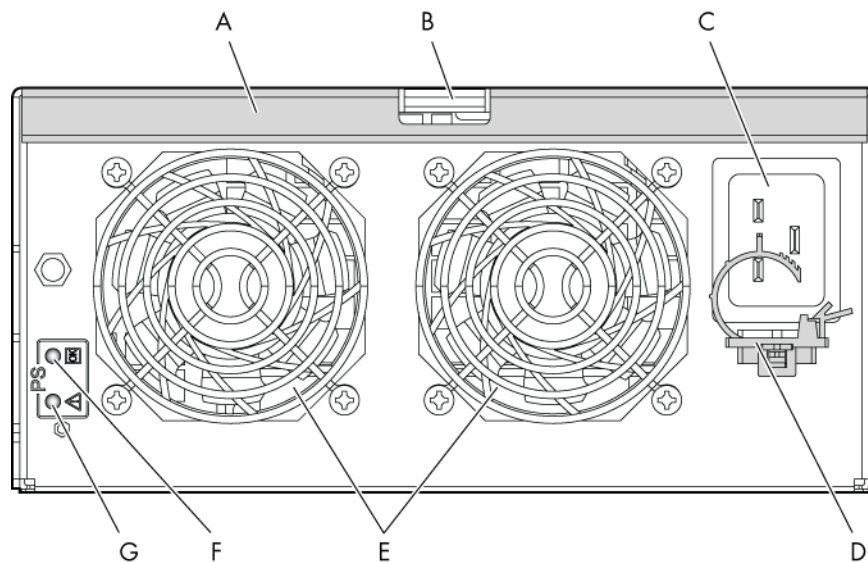

Figure 2-9. Power Supply Unit

- A. Handle
- B. Latch
- C. Power socket
- D. Cable retention
- E. Fans
- F. Power LED
- G. Fault LED

LED indicators

- **Fault LED**

The Fault LED indicator is amber.

Slow blinking or Solid On state indicates that the PSU module has failed or reached a critical state warranting its replacement.

- **Power LED**

The Power LED indicator is green.

Slow blinking green indicates that AC is being applied to the PSU module and also that the 3.3V stand by voltage is available. Once 12V is enabled this LED becomes steady.

2.5.2.3 Chassis Management Module

The CMM's primary function is to provide the bullx blade chassis-level management functionality for the bullx blade system. This includes detection, power On/Off, management status monitoring for the bullx B500 compute blades and other hardware modules within the bullx blade chassis, PSU management status monitoring, and system fan controls. The CMM is also used to manage and display the LCD messages.

The CMM is a hot-swappable module which includes of a 24-port 1GbE Ethernet switch and an OPMA daughter card, which is used as a service processor.

The Ethernet logical connections are:

- One Ethernet port to the OPMA service processor (internal)
- Eighteen Ethernet ports to bullx B500 compute blades through backplane connector (internal)
- Three Ethernet ports to RJ45 connectors on the rear side for external access

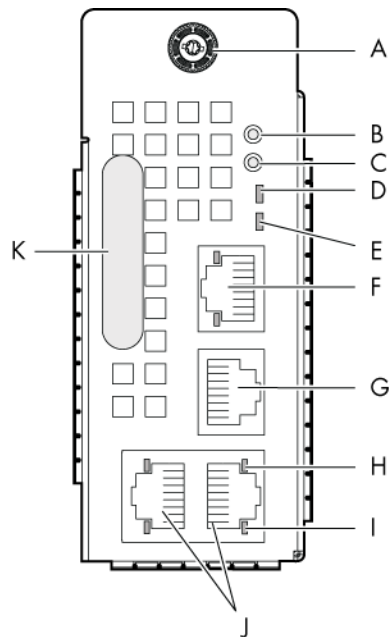

Figure 2-10. Chassis Management Module

- A. Thumb screw
- B. Reset button
- C. Default button
- D. Power and health status LED
- E. Identification LED
- F. Dynamically configurable stacking or Ethernet port
- G. Serial port
- H. Activity LED

- I. Link LED
- J. Dynamically configurable stacking or Ethernet port
- K. Handle

The other CMM features and functionalities are:

- bullx B500 compute blade execution can proceed when the CMM is down
- The Ethernet switch supports VLANs
- Has three dynamically configurable stacking or Ethernet ports
- An external COM port
- LED for status indication
- Displays status information on the LCP display panel
- Ethernet switch firmware can be loaded in-band over the Ethernet links

LED indicators

- **Identification LED**

The identification LED indicator is blue.

This indicator is a unit identifier dedicated to the maintenance operations to localize physically bullx blade chassis from the rear side. This LED is switched On simultaneously with the LCP identification LED indicator (for the front side).

The switching On/Off of this indicator is driven by the maintenance operator through the CMC (external remote SNMP command to the bullx blade chassis) or locally through the identification button of the LCP.

- **Power LED**

The power LED indicator is amber.

This indicator indicates the stand-by power presence as well as the CHC activity:

- Solid amber: 3.3V stand-by power presence
- Blinking amber: the CMC firmware is alive

- **LAN activity and status LED**

Two LEDs are integrated in each of the three Ethernet connectors: One for the link status, the second for the link activity.

2.5.2.4 Quad Switch Module

The bullx blade system supports a Quad Switch Module, based on a 36 port QDR switch Board (QSB) to provide the quad switching function between the 18 bullx B500 compute blades and the external QSFP ports. The Quad Switch Module plugs into the Midplane from the rear side of the bullx blade chassis.

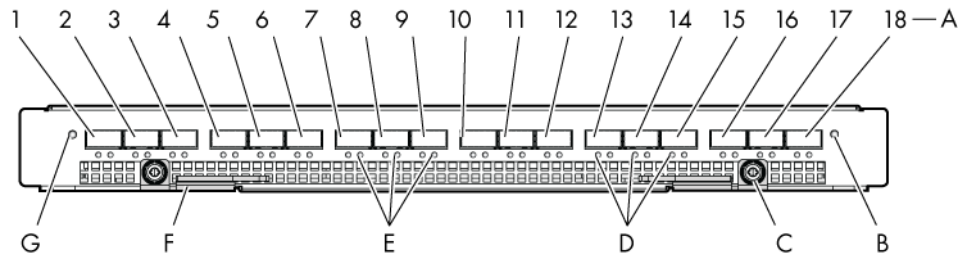

Figure 2-11. Quad Switch Module

- A. QSFP ports (1-18)
- B. Power On/AUX Power LED
- C. Thumb screw
- D. Logical link LED
- E. Physical link LED
- F. Latch
- G. Identification LED

Some of the QSM features are:

- Thirty six ports InfiniBand Switch: 18 internal and 18 external ports
- Support to QDR IB
- Ability to support passive and active cables per IB standard
- The QSM has LEDs in front for status indication
- Switch management is performed in-band on IB connections

LED indicators

- **Identification LED**
In the CHC web interface, select Maintenance tab and click Identification LED. This gives you an option to switch On/Off the identification LED of QSM.
- **Power LED**
The power LED indicator is bicolor: Amber/green indicating the power state:
 - Amber: 3.3V stand-by power presence
 - Green: 12V main power presence
- **IB link activity LED**
There are two LEDs:
 - **Physical link** -green indicates a good physical link. Blinking indicates a problem with the physical link data activity.
 - **Logical link** -Amber blinking indicates data transfer.

2.5.2.5 Ultra Capacitor Module

The UCM is an optional module that can ride through AC outages of a maximum of 250ms. During normal operation, the module gets charged by the 12V from the Midplane and stores the charge it in its Ultra capacitors. During outage, these capacitors discharge to provide the required power to the other modules like the NCB and the Quad Switch Module board (QSB). For 3v3 stand-by voltage, the PSU module has a hold time of 1000ms. Hence, the PSU module itself takes care of the 3v3 during the 250ms AC outage. The UCM connects to the Midplane through bus bars. In addition, there is control and monitoring logic that is controlled by the CMM. The control/monitoring logic operates in 3v3 standby voltage from the PSU module.

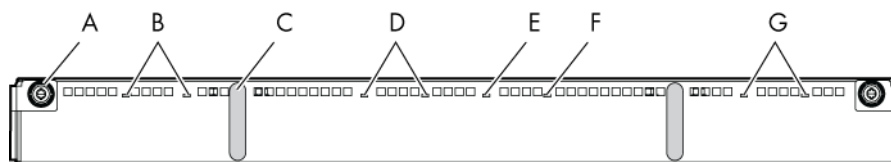

Figure 2-12. Ultra Capacitor Module

- A. Thumb screw
- B. Charge LEDs
- C. Handle
- D. Charge LEDs
- E. Identification LED
- F. Fault LED
- G. Charge LEDs

Following are the other features of the UCM:

- Able to offset power outages up to 250 ms
- Max hold-up time 480 ms

LED indicators

- **Identification LED**

The identification LED indicator is blue.

This indicator is a unit identifier dedicated to the maintenance operations to localize physically the module.

The switching On/Off of this indicator is driven by the maintenance operator (external SNMP remote command to the bullx blade chassis).

- **Charge LED**

The charge LED indicators are tricolor: green, amber, and red.

The green color means that the Ultra capacitor is fully charged, the amber color that it is being charged, the red color that it is in the process of discharging.

Each Ultra capacitor stack has its own LED indicator.

These indicators are managed by the hardware.

- **Fault LED**

The fault power LED indicator is amber.

This indicator indicates the detection of an Ultra capacitor failure.

This indicator is managed by the CHC firmware.

2.5.2.6 Ethernet Switch Module

The ESM, an optional module, is present only to provide the Ethernet switching function through the three external Ethernet ports.

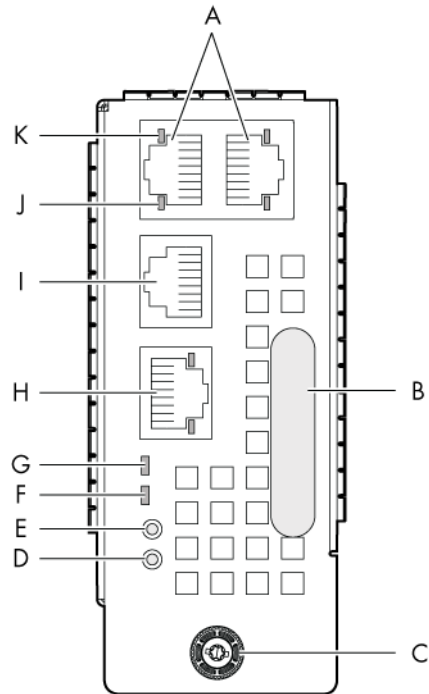

Figure 2-13. Ethernet Switch Module

- A. Dynamically configurable stacking or Ethernet ports
- B. Handle
- C. Thumb screw
- D. Reset button
- E. Default button
- F. Power and health status LED
- G. Identification LED
- H. Dynamically configurable stacking or Ethernet port
- I. Computer port
- J. Activity LED
- K. Link LED

Following are the other features of the ESM:

- Can be hot replaced
- The Ethernet switch supports VLANs
- The Ethernet has two stacking ports and a switching Ethernet port by default. Ports can be dynamically configured either as stacking ports or as GbE ports
- Has LEDs for status indication
- Ethernet switch firmware can be loaded in-band over the Ethernet links

LED indicators

- **Identification LED**

The identification LED indicator is blue.

This indicator is a unit identifier dedicated to the maintenance operations to localize physically the module.

The switching On/Off of this indicator is driven by the maintenance operator (external SNMP remote command to the bullx blade chassis).

- **Power LED**

The power LED indicator is amber.

This indicator indicates the presence of 3.3V stand-by power in the module.

This indicator is managed by the hardware.

- **LAN activity and status LED**

Two LEDs are integrated in each of the three Ethernet connectors: One for the link status, the second for the link activity.

Note The LAN activity for the buried links of the embedded Ethernet switch (between the Ethernet switch and each bullx B500 compute blade) are displayed on a LED in the front of each bullx B500 compute blade.

Chapter 3. Installing the bullx blade system in the cabinet

This chapter explains how to install the bullx blade system in a Bull Cabinet. It includes the following topics:

- Preparing the bullx blade chassis rack-mount kit
- Installing rack-mount rails in the cabinet
- Securing the bullx blade chassis in position



CAUTION

Ensure that the final combination of equipment and cabinet complies with local electric code requirements. Ensure that only trained service technicians install system rack kits and rack in a rack.

3.1 bullx blade system cabinet requirements

The following condition is required:

- bullx blade system has to be installed in a 42U Bull Cabinet

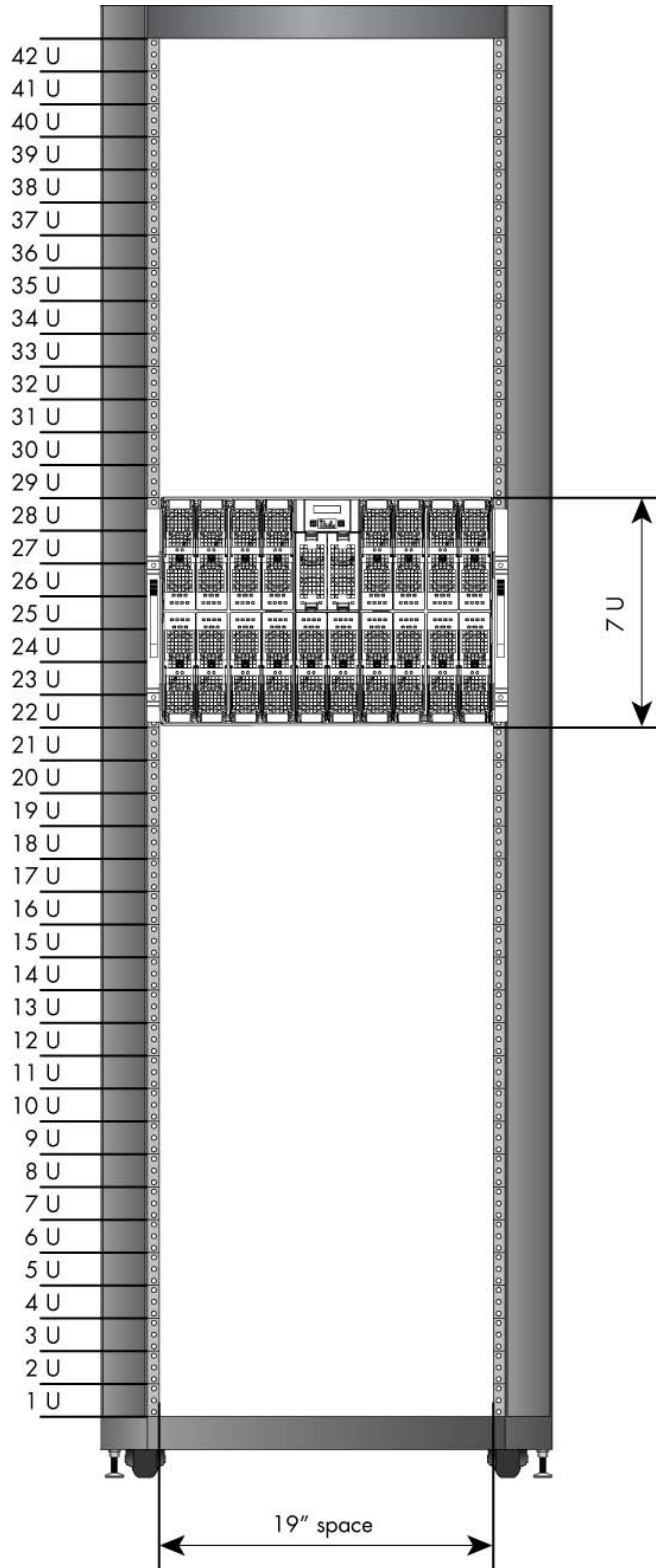

Figure 3-1. Recommended position of bullx blade system

3.2 Preparing the bullx blade chassis rack-mount kit

3.2.1 Checking the rack-mount kit

The bullx blade system is delivered with a mounting kit (Bull PN 11011422) for installation in a Bull Cabinet. The rack-mount kit contains the following items:

Item	Bull P/N/MPN
Rack-mount kit-left	11011491
Rack-mount kit-right	11011492
Shipping bracket	11011410
M5X12mm screw	92832A438
M5 Washer	98040A103
M5 Nut	90725A030

Table 3-1. Rack-mount kit items

3.2.2 Required tools

The following tools are required for:

- T25 Torx screwdriver for M5 screws
- Spanner or nut driver for holding M5 nut

3.3 Installing rack-mount rails in the cabinet

Note The rack rails each comprise a fixed part and a mobile part.

The following steps help you to install rack-mount rails in the cabinet:

1. Fully extend the rack rail.
2. Prepare two brackets.
3. Assemble the two brackets on the fixed part (vertical rails) of the rack rail, taking care to place the right-angle bracket bends toward the front and rear ends of the fixed part:
 - Front and Rear ends: Insert the two M5X12 screws with M5 washers through the right angled bracket bends and rack vertical rails.

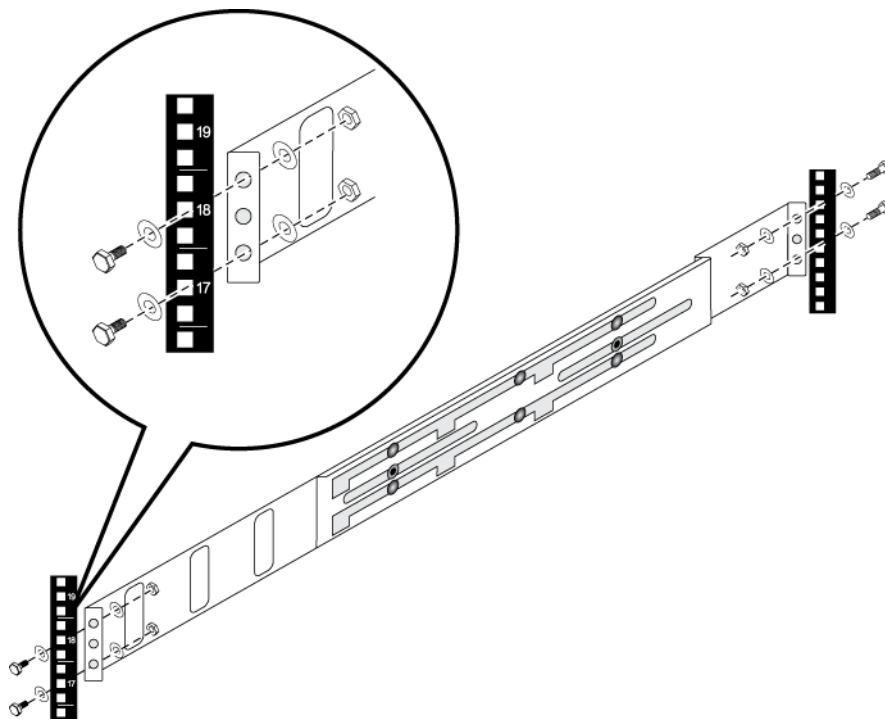

Figure 3-2. Installing rack-mounted rail in cabinet

3.4 Securing the bullx blade chassis in position



DANGER

The bullx blade chassis weighs 125 kgs. Use suitable lifting equipment like forklift, cranes... for lifting the bullx blade chassis.

1. From the front of the cabinet, insert bullx blade system into the rack and ensure that it is sitting on the Teflon tape properly, which is stuck on the bullx blade chassis.
2. Push the bullx blade chassis fully backward till it is flush with the cabinet frame.
3. Tighten the two captive screws securing the bullx blade chassis to the cabinet rack.

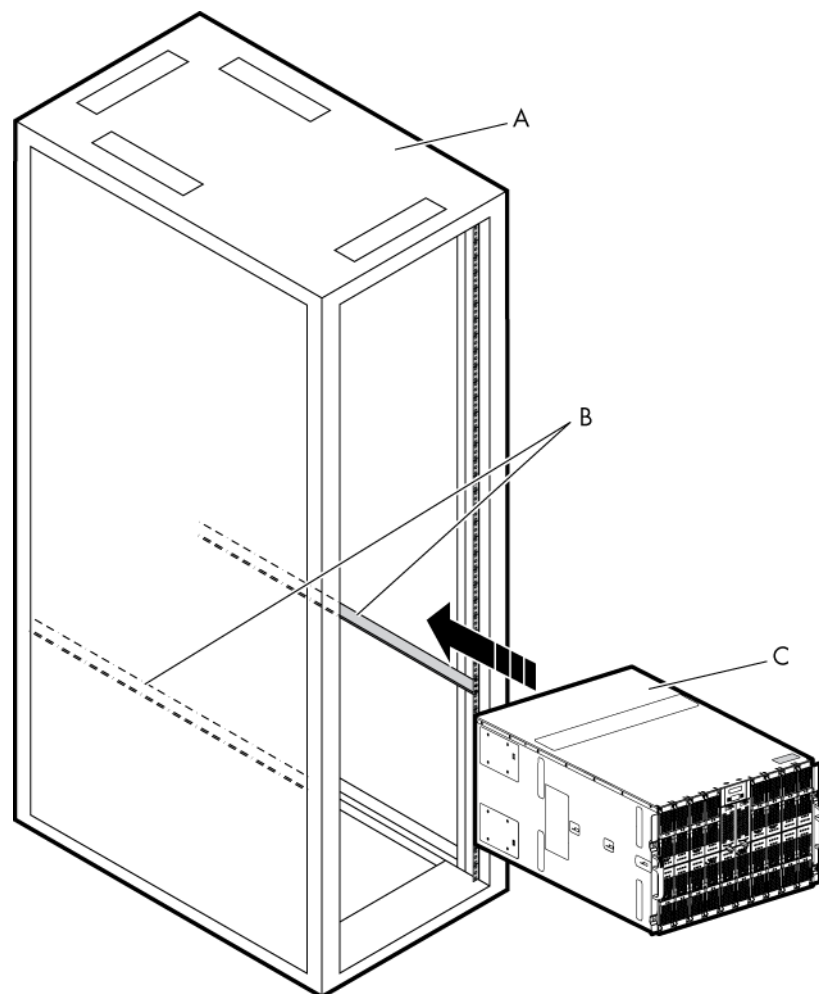

Figure 3-3. Securing the bullx blade chassis in the cabinet

- A. Cabinet
- B. Rack-mounted rails
- C. bullx blade chassis

Chapter 4. Connecting and testing the bullx blade system

This chapter provides instructions for connecting and configuring the bullx blade system.

4.1 Connecting the bullx blade system to the site power supply

Plug one end of each power cord into a PSU module and the other end into a Power Distribution Unit (PDU) that is plugged into an appropriate electrical outlet.

Note The drawer powering depends on the setting **Start Mode**. With the setting **Deep Standby** the bullx B500 compute blades are standby off, **Light Standby** standby on, and **Unlocked** powered off.

4.2 Powering on the bullx blade system for the first time

After you connect the bullx blade system to the power supply, the CMM comes up first. However, the bullx B500 compute blades in the bullx blade system are not turned on. You can power on the blades with either of the two options:

- Press the **power-control** button on the LCP
- Or
- Through the Chassis Hardware Console > **System Control** > **Power** page, select the blades and click **Power On** button

-
- Notes**
- To use the Chassis Hardware Console (CHC), cabling of the CMM is required first explained in section 4.5 Connecting the bullx blade system to the site LAN
 - If you click **Power On** button in **Whole Chassis power**, then all the blades are powered On provided that the **Drawer Power On Mode** is set to **Full Power On**
 - By default, the LCP button is disabled
-

4.3 Checking correct operation

To check for bullx blade system's correct operation:

- Ensure that the following LEDs are glowing – CMM ID should be blinking, irrespective of the **Power Mode** setting, you should see:
 - a. The CMM ID LED starts blinking after a few seconds of power On.
 - b. The Fan Fault LED should not be glowing.
- If **Start Power Mode** is set to **Unlocked Power**, then the bullx blade chassis fans should start running and the Power LED on the blade should be Amber (the blade is in stand by mode)
- If **Start Power Mode** is set to **Full Power On**, then the bullx blade chassis fans should start running and the Power LED on the blade should be Amber (the blade is in stand by mode). After a few seconds, the Power LED should turn Green

Note Default **Start Power Mode** is **Unlocked Power**.

4.4 Powering off the bullx blade system

There are two types of powering off the bullx B500 compute blades in the bullx blade system:

- **Power Off**, also called as soft power off, initiates a graceful shutdown of the Operating System (OS). The user intervention may be required based on the power policy set in the OS. If Linux is running on the blade and if you click **Power Off** button on the CHC, then a prompt is displayed on the Linux console indicating that you can shutdown the Linux OS.
- **Forced Power Off** does not provide an opportunity to shutdown the OS. It directly removes the power from the bullx B500 compute blade. This is not a recommended option in normal circumstances.

You can power off the bullx blade system by turning off the bullx B500 compute blades and disconnecting the bullx blade system from the power source. Wait at least 30 seconds for the bullx B500 compute blades drives to stop spinning. You can power off the bullx B500 compute blades with either of the two options:

- Press the **power-control** button on the LCP for at least four seconds
or
- Through the web interface of the CMM in **System Control > Power page**, click **Power Off** button

Web interface

Web interfaces accept input and provide output by generating web pages, which are transmitted via the Internet that can be later viewed with a web browser.

Launching a web interface

Complete the following steps to launch a web interface:

1. Open the Internet Explorer.
2. Disable any http proxy server.
3. Launch web session using `http:// IP address of the CHC, BHC or Ethernet switch`.

Note If you click **Power Off** button in **Whole Chassis power**, then all the blades are powered off.



CAUTION

The power-control button on the device and the power switch on the power supply do not turn off the electrical current supplied to the device. The device also might have more than a power cord. To remove complete electrical current from the device, ensure that all power cords are disconnected from the power source.

Note After you disconnect the bullx blade system from power, wait at least five seconds before you connect the bullx blade system to power again.

4.5 Connecting the bullx blade system to the site LAN

To manage the bullx blade system and bullx B500 compute blades, you must first set up the remote connection through the Ethernet port on the CMM.

Complete the following steps to connect the Ethernet cable to the CMM.

1. Connect one end of a Category 5 or higher Ethernet cable to the Ethernet port on the CMM.
2. Connect the other end of the Ethernet cable to the network.

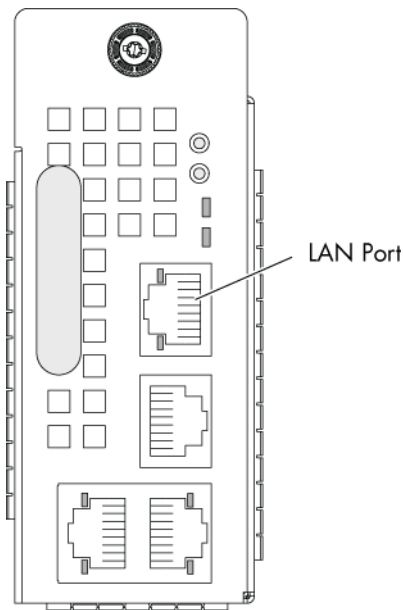

Figure 4-1. Connecting the bullx blade system to the site LAN

Note Check that the Ethernet LED is blinking to ensure that the network connection is working.

Ethernet link LED

When this green LED is lit, there is an active connection through the port to the network.

Ethernet activity LED

When this green LED is blinking, there is activity through the port over the network link.
When this amber is blinking, it indicates a network link.

If the DHCP server is configured, then IP addresses are assigned for the following modules:

- Chassis Management Module
 - Ethernet Switch Module
3. With the Chassis Hardware Console (CHC) IP address log on to the CHC web interface. If you power On the blades, then each blade gets three IP addresses (BHC IP, Eth0 IP, and Eth1 IP) from the DHCP server.

4. If you are configuring the CHC's IP address for the first time, you need to give specific IP address to CHC based on:
MAC address
or
BULL_Chassis_CMC

4.6 Testing LAN connections

The below steps help you test the LAN connections:

1. Check the link activity if it is blinking; if not recheck the LAN cable connection at the bullx blade system or LAN outlet ends.
2. Ping to the IP address of the Ethernet switch (IP address of Ethernet switch can be found from the DHCP server log based on **MAC address** or **BULL_Blade_NCB_BMC**.
 - If you cannot ping, then check the LAN connections or test the Ethernet switches
 - If you can ping, then log on to Blade Hardware Console Ethernet switch web interface
3. Ping to the CHC and log into the web interface.

4.7 Setting up the bullx blade system for remote access via the CHC

From a computer in the site LAN, access the Chassis Hardware Console. Following are the choices for CHC IP address configuration:

- Static IP address
- Automatic address by DHCP server
- Automatic address by BOOTP server

The default is auto-configuration with DHCP server. To facilitate the sort of the MAC addresses received from different components or providers, the CHC frames destined to the DHCP server are tagged as "BULL_Chassis_CMC" specifically. The configuration can be modified through the serial access of the CHC (COM connector of the CMM panel).

CHC firmware interfaces

The software interfaces supported by the CHC are:

- SNMP V3
- IPMI V2.0
- WEB GUI
- SMASH/CLP

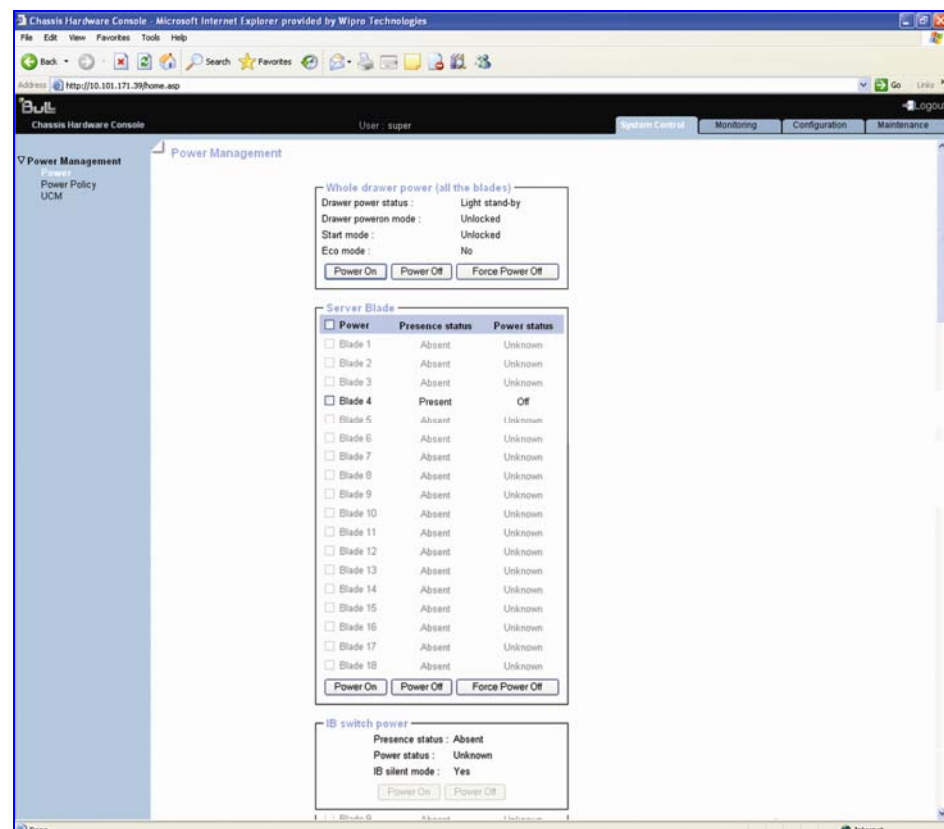

Figure 4-2. Chassis Hardware Console page

Note For more information on configuring the bullx blade system, see *bullx blade chassis User's Guide*.

4.8 Setting up the bullx B500 compute blades for remote access via the BHC

Log on to Ethernet Switch page to check if the link is up and running for the corresponding BHC, if not then you should log into CHC web interface and from CHC configure BHC network link. There you can configure the choices for Blade Hardware Console (BHC) IP address. Following are the choices for BHC IP address configuration:

- Static IP address
- Automatic address by DHCP server
- Automatic address by BOOTP server

Once the configuration is done, wait for 10 seconds and then ping the IP address of the BHC. The default is auto-configuration with DHCP server. To facilitate the sort of the MAC addresses received from different components or providers, the BHC frames destined to the DHCP server are tagged as "BULL_Blade_NCB_BMC" specifically. The configuration can be modified by the CHC through the management I2C interface provided by each bullx B500 compute blade.

The CHC can define a static address, request the BHC to return to default settings or define as static the last address received from the DHCP server.

BHC firmware interfaces

The software interfaces supported by the BHC are:

- IPMI V2.0
- WEB GUI
- SMASH/CLP
- KVM redirection
- Virtual media redirection
- Serial over LAN

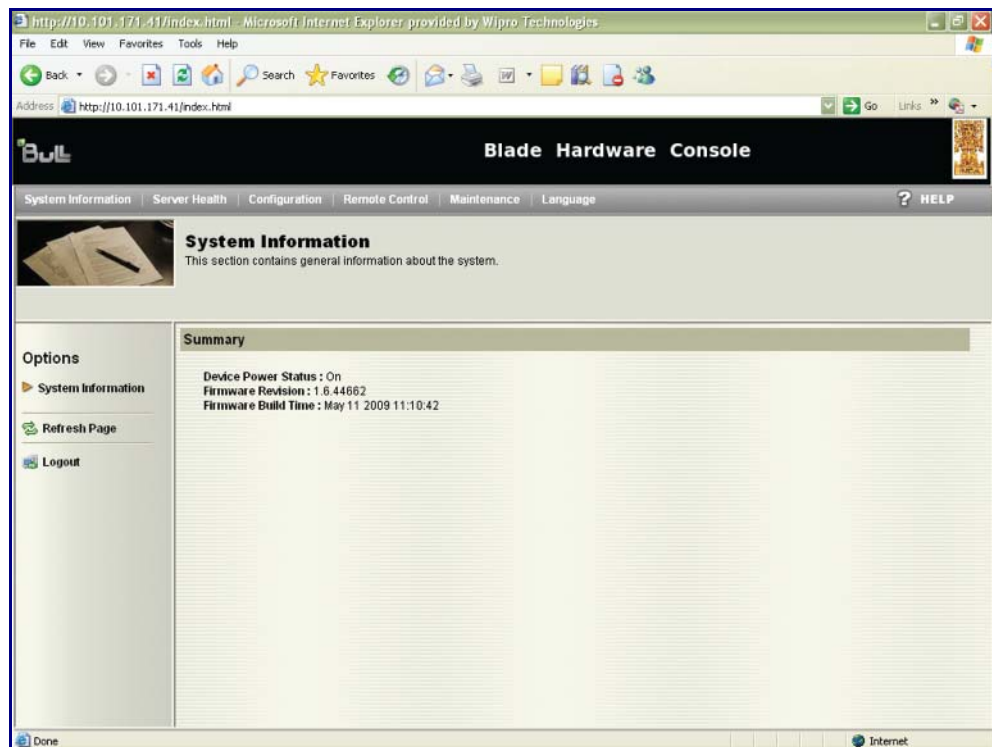

Figure 4-3. Blade Hardware Console page

To connect to the console of the blade, you can use the KVM redirection feature of the BHC.

Note You should have Java web server installed on your system. This comes with JDK 5.6 and above versions.

From the BHC, follow these steps:

1. Click **Remote Control** to see the Console Redirection window option.
2. Click the **Console Redirection** to see **Launch Console** option.
3. Click **Launch Console** to see a pop up of the KVM console window.
This connects the console to the blade.

See *For more information on configuring the bullx B500 compute blades, see bullx B500 compute blade User's Guide.*

Appendix A. bullx blade system specifications

The bullx blade system is delivered rack-mounted in 42U cabinet.

You may consult the following web site for general site preparation information:

<http://www.cs.bull.net/aise>.

Cabinet Dimensions /Weight	
Unpacked	Unpacked
Height: 30.7 cm (12 in) Width: 44.6 cm (17.55 in) Depth: 74.7 cm (29.4 in) Weight (max): 125 kg (275 lb) (Approximate with UCM)	Height: 62 cm (24.4 in) Width: 60 cm (23.62 in) Depth: 90 cm (35.43 in) Weight (max): 155 kg (341 lb) (Approximate with UCM)
Service Clearance	
Front	150 cm
Rear	100 cm
Side (free side)	100 cm
Operating Limits	
Dry bulk temperature range	+10 °C to +30 °C (50 °F to 86 °F)
Relative humidity (non-condensing)	8% to 90% (Gradient 5% /h)
Max. wet bulb temperature	+16 °C (60.8 °F)
Moisture content	0.019 kg water/kg dry air
Pressure / Elevation	Sea level < 2500 m
Optimum Operational Reliability	
Temperature	+ 10 °C to 35 °C (50 °F to 95 °F) Gradient 5° /h
Hygrometry	50% (+ 5%)
Non-Operating Limits	
Dry bulk temperature range	+5°C to +50°C (+41°F to +122°F)
Relative humidity (non-condensing)	5 to 95% (Gradient 30 %)
Max. wet bulb temperature	+28°C (+82.4°F)
Moisture content	0.024 kg water/kg dry air

Shipping Limits	
Dry bulk temperature range	-40 °C to +70 °C (-40 °F to 158 °F)
Relative humidity (non-condensing)	Gradient 25° /h 5 to 95 % Gradient 30 % / h
Acoustic Power at Room Temperature +20°C (+68°F)	
System Running	System Idle
85 dBA	82 dBA
Power Cable	
Three pin, 250 V AC, 16 A	
AC 16 A per PSU Cable type Connector type	4 per bullx blade system Normal power cables with 16 A rating IEC C19 outlet on PSU side and IEC C20 on the main side.
It is mandatory for power lines and terminal boxes to be located within the immediate vicinity of the system and to be easily accessible.	
Electrical Specifications	
Current draw Power consumption Thermal dissipation Input ratings	12.5 A 10000 VA (max power drawn from mains per bullx blade system) 8500 W (max power dissipated per bullx blade system) 210-240VAC, 50/60Hz
Europe	
Nominal voltage Voltage range Frequency	230VAC (Phase / Neutral) 210 to 240V AC 50Hz
United States of America	
Nominal voltage Voltage range Frequency	230 VAC (Phase / Neutral) 210 to 240V AC 60 Hz 0.3%
Breaker Protection (Mains Power)	
PDU Maximum inrush current	16A per PSU 210A / per quarter period

Table A.1. bullx blade system specifications

Glossary

A

ABR: Automatic BIOS Recovery

This invention describes a recovery method for a computer system that has corrupted initialization, or boot code. This is done using checksum for detecting the corruption and a backup copy of the boot code for recovery.

AC: Alternate Current

Alternating Current generated by the power supply. See also DC.

ACPI: Advanced Configuration and Power Interface

Open industry specification co-developed by Hewlett-Packard, Intel, Microsoft, Phoenix, and Toshiba, ACPI establishes industry-standard interfaces enabling OS-directed configuration, power management, and thermal management of server platforms.

Address

A label, name or number that identifies a location in a computer memory.

Archive: (Archive file)

A file that is a copy of a history file. When a history file is archived, all messages are removed from the history file.

ASR: Automatic Server Restart

The Automatic Server Restart event occurs when the operating system locks up and no longer responds. Subsequently, a system restart (reboot) begins.

B

Backup

A copy of data for safe-keeping. The data is copied from computer memory or disk to a floppy disk, magnetic tape or other media.

BHC: Blade Hardware Console

Web based GUI, used to control and monitor an individual bullx B500 compute blade in a bullx blade chassis.

BIOS: Basic Input Output System

A program stored in flash EPROM or ROM that controls the system startup process.

BIST: Built - In Self Test

It is a mechanism that permits a machine to test itself.

Blade fans

The two counter rotating fans that are mounted in each bullx B500 compute blade to cool the bullx B500 compute blade.

BMC: Baseboard Management Controller

It is an embedded microcontroller surrounded by memory, interfaces, and sensors.

BOOTP

A network protocol used by a network client to obtain an IP address from a configuration server.

Byte

A group of eight binary digits (bit) long that represents a letter, number, or typographic symbol.

C

CENELEC: Comité européen de normalisation en électronique et en électrotechnique

Certificate Authority

It is an entity that issues digital certificates for use by other parties.

CFR: Code of Federal Regulations

Channel

A channel is a series of related web pages that provide a range of information on a particular topic.

CHC: Chassis Hardware Controller

Webs based GUI, used to control and monitor the whole of the BULLX BLADE SYSTEM.

Chipset

The term chipset is commonly used to refer to a set of specialized chips on a computer's motherboard or an expansion card.

CISC: Complex Instruction-Set Computer

A computer instruction set architecture (ISA) in which each instruction can execute several low-level operations, such as a load from memory, an arithmetic operation, and a memory store, all in a single instruction. The term was retroactively coined in contrast to reduced instruction set computer (RISC).

CLP: Command Line Protocol

The command line protocol will specify the syntax and semantics used to allow the manipulation of the Managed Elements within servers, as collections or individually.

CMB: Chassis Management Board

Board in the CMM hosting a 1 Gb Ethernet switch, 24 ports, as well as a SO-DIMM 200 connector to plug the OPMA daughter board (CMC)

CMC: Chassis Management Controller

The CMC is daughter card, M3-G4 from Raritan, based on OPMA.

CMM: Chassis Management Module

A module used to manage the bullx blade chassis hardware and enables the inter-networking of different components of bullx blade chassis.

COM: Complementary Metal Oxide Semiconductor

It is a major class of integrated circuits. CMOS technology is used in microprocessors, microcontrollers, static RAM, and other digital logic circuits.

COM1 or COM2:

The name assigned to a serial port to set or change its address. See Serial Port.

CPU: Central Processing Unit

It is an electronic circuit that can execute computer programs.

CRU: Customer Replaceable Unit**CSR: Certificate Signing Request**

Message sent from an applicant to a certificate authority in order to apply for a digital identity certificate.

D**DC: Direct Current**

Direct Current generated by the power supply. See AC.

DDR3: Double Data Rate 3

It is a random access memory interface technology used for high bandwidth storage of the working data of a computer or other digital electronic devices.

Default Gateway

A Default Gateway is the node on the computer network that is chosen when the IP address does not belong to any other entities in the Routing Table.

Default setting

The factory setting that your server uses unless instructed otherwise.

Density

The capacity of information (bytes) that can be packaged into a storage device.

DES: Data Encryption Standard

A block cipher (a form of shared secret encryption) that is based on a symmetric-key algorithm that uses a 56-bit key.

DHCP: Dynamic Host Configuration Protocol

It is a network application protocol used by devices (DHCP clients) to obtain configuration information for operation in an Internet Protocol network.

Disk Drive or HDD

A device that stores data on a hard or floppy disk. A floppy disk drive requires a floppy disk to be inserted. A hard disk drive has a permanently encased hard disk.

Diskless

Personal computer without disk drives, which employs network booting to load its operating system from a server.

DIMM: Dual In-line Memory Module

The smallest system memory component.

DIMM socket

The socket used in Bullx blade system is for 240-pin DDR-3 memory modules.

DN: Distinguished Name

A distinguished name (DN) is a LDAP entry that uniquely identifies and describes an entry in a directory (LDAP) server

DNS: Domain Name System

It's a hierarchical naming system for computers, services, or any resource participating in the Internet.

DOS: Disk Operating System

It is a shorthand term for several closely related operating systems.

DRAM: Dynamic Random Access Memory

It is the most common type of random access memory (RAM).

DP: Dual Processor

Systems in which the two processors can either be located on the same motherboard or on separate boards.

E

ECC: Error Correcting Code

An error-correcting code is an algorithm for expressing a sequence of numbers such that any errors which are introduced can be detected and corrected (within certain limitations) based on the remaining numbers.

EP: Efficient Performance

ESM: Ethernet Switch Module

The hardware is same as that of CMM without the OPMA card for management. See CMM.

Ethernet Controller

The Ethernet controller is located on either a MiniPCI card, Communications Daughter Card (CDC), or integrated on the system board.

Ethernet interconnect

It is used to aggregate traffic between clients and 'server farms,' and for connecting Fast Ethernet switches.

F

Fan blade

Refers to the *bullx blade system* fan modules which are located at the front of the system, below the LCP.

FC-LGA: Flip-Chip Land Grid Array

Nehalem CPU socket connectors on the Blade Server

FCC: Federal Communications Commission

Firmware

An ordered set of instructions and data stored to be functionally independent of main storage.

FQDN: Fully Qualified Domain Name

A domain name that specifies its exact location in the tree hierarchy of the Domain Name System (DNS).

FRU: Field Replaceable Unit

A component (board, module, fan, power supply...) that is replaced or added by Customer Service Engineers as a single entity.

Full Duplex

A Full Duplex system provides for communication in both directions at a time.

G

GB: GigaByte

One GB equals to 1,073,741,824 bytes.

GT/s: Giga Transfer per second

One GT equals four Gbytes.

GUI: Graphical User Interface

GPU: Graphical Processing Unit

It is a specialized processor that offloads 3D graphics rendering from the microprocessor.

H

Half Duplex

A Half Duplex system provides for communication in both directions at a time.

HDD: Hard Disk Drive

A device that stores data on a hard or floppy disk. A hard disk drive has a permanently encased hard disk.

High Performance Computing cluster

A computer cluster is a group of linked computers, working together closely so that in many respects they form a single computer.

HOST name

It is a unique name by which a network-attached device (which could consist of a computer, file server, network storage device, fax machine, copier, cable modem, etc.) is known on a network.

Hot plugging

The operation of adding a component without disturbing the system activity.

Hot swapping

The operation of removing and replacing a faulty component without interrupting system activity.

HPC: High Performance Computing

Uses supercomputers and computer clusters to solve advanced computation problems.

HTML: Hyper Text Markup Language

It is the predominant markup language for web pages.

HTTP: Hyper Text Transfer protocol

In the World Wide Web, a protocol that facilitates the transfer of hyper text-based files between local and remote systems.

HTTPS: Hyper Text Transfer Protocol Secure

Combination of the Hypertext Transfer Protocol and a cryptographic protocol.

I

I2C: Inter Integrated Circuit

Simple bi-directional 2-wire bus for efficient inter-IC control

IB: InfiniBand

The InfiniBand™ Architecture (IBA) is an industry standard that defines a new high-speed switched fabric subsystem designed to connect processor nodes and I/O nodes to form a system area network.

IB Switch Module

This is same as QSM or Quad.

iBMC: Integrated Baseboard Management Controller

Specialized microcontroller that is integrated in the motherboard of a server. The BMC is the intelligence in the Intelligent Platform Management Interface (IPMI) architecture. The BMC manages the interface between system management software and platform hardware.

ID: Identification**IEC: International Electrotechnical Commission**

World's leading organization that prepares and publishes International Standards for all electrical, electronic and related technologies

ILB: I/O Legacy Board

Video, LAN, USB, etc...

INCA

INtegrated Cluster Architecture. It is a high-density server system.

bullx B500 compute blades

Refers to the bullx B500 compute blade or NCB.

bullx blade system

Refers to the overall system including the bullx blade chassis, bullx B500 compute blades, and Modules.

Input – Output

Refers to the communication between an information processing system (such as a computer), and the outside world – possibly a human, or another information processing system.

Intelligent Drive Electronics/Integrated Device Electronics

It is an interface for mass storage devices, in which the controller is integrated into the disk or CD-ROM drive.

Interconnect

It is a point-to-point processor interconnects developed by Intel to compete with Hyper Transport.

IP: Internet Protocol

A protocol used for communicating data across a packet-switched internetwork using the Internet Protocol Suite, also referred to as TCP/IP.

IPMI: Intelligent Platform Management Interface

A specification owned by Intel which describes mechanisms and devices to completely offload the task of managing system hardware from the primary CPU.

ISO: International Organization for Standardization

World's largest developer and publisher of International Standards.

J**JTAG: Joint Test Action Group**

It is the common name used for the IEEE 1149.1 standard entitled Standard Test Access Port and Boundary-Scan Architecture for test access ports used for testing printed circuit boards using boundary scan.

K**KVM: Keyboard-Video-Mouse**

It is a hardware device that allows a user to control multiple computers from a single keyboard, video monitor and mouse.

L**LAN: Local Area Network**

A group of computers linked together within a limited area to exchange data.

LCD: Liquid Crystal Display

It is an electronically-modulated optical device shaped into a thin, flat panel made up of any number of color or monochrome pixels filled with liquid crystals and arrayed in front of a light source (backlight) or reflector.

LCP: Local Control Panel

Module consisting of a controller, a LCD color display, a green and a blue LED and a Power ON button.

LDAP: Lightweight Directory Access Protocol

An application protocol for querying and modifying directory services running over TCP/IP.

LED: Light Emitting Diode

A small electronic device that glows when current flows through it.

M

MAC: Mandatory Access Control

A type of access control by which the operating system constrains the ability of a subject or initiator to access or generally perform some sort of operation on an object or target.

Memory

Computer circuitry that stores data and programs.

Memory bandwidth

It is the rate at which data can be read from or stored into a semiconductor memory by a processor

MIB: Management Information Base

Type of database used to manage the devices in a communications network.

Microprocessor

An integrated circuit that processes data and controls basic computer functions.

Midplane

Midplane is a passive board that provides the physical and electrical connectivity to all the hardware modules.

MMX: MultiMedia eXtensions

A single instruction, multiple data (SIMD) instruction set designed by Intel, introduced in 1997

MTU: Maximum Transmission Unit

It is the largest size packet or frame, specified in octets (eight-bit bytes), that can be sent in a packet- or frame-based network such as the Internet.

N

Nehalem CPU Board

This refers the bullx B500 compute blade or NCB.

Network interface

A point of interconnection between a user terminal and a private or public network.

NFS: Network File System

Protocol originally developed by Sun Microsystems in 1984, allowing a user on a client computer to access files over a network in a manner similar to how local storage is accessed.

NTP server

A protocol for synchronizing the clocks of computer systems over packet-switched, variable-latency data networks.

NVRAM: Non-Volatile Random Access Memory

A type of RAM that retains its contents even when the computer is powered off.

O

OPMA board

bullx blade system uses an OPMA based daughter card as the Chassis Management Controller or CMC. The CMC is a plugged into the CMM module.

OPMA: Open Platform Management Architecture

Is an open, royalty free standard for connecting a modular, platform hardware management subsystem (a "mCard") to a computer motherboard.

OS: Operating System

The software which manages computer resources and provides the operating environment for application programs.

Out-of-band compliant interface

It refers to communications which occur outside of a previously established communications method or channel.

P

Password

A security feature that prevents an unauthorized user from operating the system.

PCI - E slots

Slots for add in PCI-E cards. *bullx blade system* does not have any PCI-E slots.

PCI – Express

It is a serial transmission interface established by PCI-SIG. This can replace the conventional parallel PCI bus.

PCI - Express slots

Slots for add in PCI-E cards. *bullx blade system* does not have any PCI-E slots.

PDU: Power Distribution Unit

Power bus used for the connection of peripheral system components.

PET: Platform Event Trap

Automatic alert sent by a Device over the network. (IPMI standard)

Ping

A basic Internet program that lets you verify that a particular IP address exists and can accept requests. The verb 'to ping' means the act of using the ping utility command.

Power consumption

Energy consumption is the consumption of energy or power.

POST: Power On Self Test

When power is turned on, POST is the diagnostic testing sequence that a computer runs to determine if hardware is working properly.

Power redundancy

Preboot execution Environment

It is an environment to boot computers using a network interface independently of available data storage devices (like hard disks) or installed operating systems.

PSMI: Power Supply Management Interface

Communication with the power supply to access currents, voltages, fan speeds, and temperatures.

PSU: Power Supply Unit Module

Refers to the power supply unit that supplies 12V and 3v3 standby to the *bullx blade system*. It takes in the AC input voltages and converts them to the DC voltages.

PWM fan: Pulse Width Modulation fan

PWM involves rapidly switching the supply to the fan on and off. By altering the relative on to off times the average voltage "seen" by the fan is also altered.

Q

QDR InfiniBand: Quad Data Rate InfiniBand

Refers to Quad Data Rate InfiniBand data speed, which is 10Gbps per lane.

Quad Data Rate

It is a communication signaling technique wherein data is transmitted at four points in the clock cycle.

QSB: QDR Switch Board

Board within the Quad Switch Module

QSFP: Quad Small Form-factor Pluggable

Interconnect technology that is much lower power-consuming

QSM: Quad Switch Module

bullx blade system InfiniBand Switch

R

RADIUS: Remote Authentication Dial-In User Service

Networking protocol that provides centralized Authentication, Authorization and Accounting (AAA) management for computers to connect and use a network service

RAM: Random Access Memory

A temporary storage area for data and programs. This type of memory must be periodically refreshed to maintain valid data and is lost when the computer is power off. See NVRAM.

RAS: Reliability Availability Serviceability

These factors help to ensure the integrity of the data stored on your bullx B500 compute blade; that your bullx B500 compute blade is available when you want to use it; and that should a failure occur; you can easily diagnose and repair the failure with minimal inconvenience.

RISC: Reduced Instruction-Set Computer

A CPU design strategy emphasizing the insight that simplified instructions that "do less" may still provide for higher performance if this simplicity can be utilized to make instructions execute very quickly.

RJ45

Eight-contact regular jack.

RoHS: Restriction of Certain Hazardous Substances

This Directive bans the placing on the EU market of new electrical and electronic equipment containing more than agreed levels of lead, cadmium, mercury, hexavalent chromium, polybrominated biphenyl (PBB) and polybrominated diphenyl ether (PBDE) flame retardants.

RPM: Rotations Per Minute

S

SATA: Serial Advanced Technology Attachment

Storage-interface for connecting host bus adapters to mass storage devices such as hard disk drives and optical drives.

SEL: System Event Log

Hardware log of server (512 entries)

Serial Port

Connector that allows the transfer of data between the computer and a serial device. See COM1 or COM 2. Shell is a Unix term for the interactive user interface with an operating system.

bullx B500 compute blade

The blades that provide dual QDR InfiniBand (IB) channel to the InfiniBand Switch.

SIMD: Single Instruction, Multiple Data

Technique employed to achieve data level parallelism.

SKU: Stock Keeping Unit

It is a unique identifier for each distinct product and service that can be ordered from a supplier.

SMASH: System Management Architecture for Server Hardware

It is a suite of specifications that deliver industry standard protocols to increase productivity of the management of a data center.

SMT: Simultaneous Multi-Threading

Ability of a single physical processor to simultaneously dispatch instructions from more than one hardware thread

SMTP: Simple Mail Transfer Protocol

An internet standard for electronic mail (e-mail) transmission across Internet Protocol (IP) networks.

SNMP: Simple Network Management Protocol

The protocol governing network management and the monitoring of network devices and their functions.

SO-DIMM: Small Outline Dual In-line Memory Module

Smaller alternative to a DIMM, being roughly half the size of regular DIMMs

SSD: Solid State Drive

It is a data storage device that uses solid-state memory to store persistent data.

SSH: Secured Shell

SSH is a network protocol that allows data to be exchanged using a secure channel between two networked devices.

SSL: Secure Socket Layer

They are cryptographic protocols that provide security and data integrity for communications over networks such as the Internet

T**TELNET: Telecommunication network**

Telnet is a network protocol used on the Internet or local area networks to provide a bidirectional interactive communications facility.

U**UCM: Ultra Capacitor Module**

The module can ride through AC outages of max. 250ms.

UID: Unit Identifier

Unsigned integer value that identify users within the Linux kernel.

UPS: Uninterrupted Power Supply

Supplying power from a separate source when utility power is not available.

URL: Uniform Resource Locator

The address of a file (resource) accessible on the Internet.

USB: Universal Serial Bus

A plug-and-play interface between a computer and add-on device. The USB interface allows a new device to be added to your computer without having to add an adapter card or even having to turn the computer off.

UTC: Coordinated Universal Time

A time standard based on International Atomic Time (TAI) with leap seconds added at irregular intervals to compensate for the Earth's slowing rotation.

V**VLAN: Virtual Local Area Network**

A local area network with a definition that maps workstations on some other basis than geographic location (for example, by department, type of user, or primary application).

VT-d: Virtualization for Directed I/O

The VT-d architecture enables system software to assign one or more I/O devices to a protection domain. DMA isolation is achieved by restricting access to a protection domain's physical memory from I/O devices not assigned to it, through address-translation tables.

VT-x: Virtualization Technology for x86

Method by which x86-based "guest" operating systems can run within another "host" x86 operating system, with little or no modification of the guest OS.

W**WOL: Wake-on LAN**

A feature that provides the ability to remotely power on a system through a network connection.

Web Service for Management

Is a general Web services protocol based on SOAP for managing systems such as PCs, servers, devices, Web services and other applications, and other manageable entities.

WEEE: Waste Electrical and Electronic Equipment

Loose category of surplus, obsolete, broken, or discarded electrical or electronic devices.

WS-MAN: Web Service Management

Public standard for remotely exchanging management data with any computer device that implements the protocol.

X**XML: eXtended MarkUp Language**

General-purpose specification for creating custom markup language

Y

No entries.

Z

No entries.

Index

A

Alterations, 5
Automatic address, 48

C

Chassis
 interconnectivity, 16
Chassis Management Module, 9, 25
Components, 47
Connecting the bullx blade system to the site LAN,
 44

D

Delivery, 1

E

Ethernet Switch Module, 30
 Identification LED, 31
 LAN activity and status LED, 31
 Power LED, 31
Expansion, 10
External port, 27

F

Fan blade, 20
firmware interfaces, 47
Forced power Off, 43
Front view, 16
Functionality, 10

G

Global power, 13
Glowing, 42

I

Installing
 rack rail, 36

L

LAN connections, 46
LED
 Ethernet activity LED, 44
 Ethernet link LED, 44
 IB link activity LED, 28
 Identification, 21
 Power, 21
Local Control Panel, 21

M

Management
 monitoring, 11

N

Nehalem CPU blade, 9

O

OPMA service, 25

P

Packaged, 3
Power LED
 bicolor, 28
Power On, 41
Power Supply Unit, 23
Powering off, 43
Powering on the bullx blade system, 41
Preparing
 rack mount kit, 33
PSU
 hot swappable, 23

Q

Quad Switch Module, 9
Quad Switch Module, 27

R

Remote access

via BHC, 47
via the CHC, 47

Removing
shipping bracket, 4

RJ45, 25

S

Server blade, 16, 18
Fault LED, 18
HDD activity LED, 19
IB activity LED, 19
LAN 0 activity LED, 19
LAN1 activity LED, 19
Power LED, 18
specific features, 18

SNMP command, 26

T

Turned On, 21

U

Ultra Capacitor Module, 28
Charge LED, 29
Fault LED, 29
Identification LED, 29

W

Web interface, 43

BULL CEDOC
357 AVENUE PATTON
B.P.20845
49008 ANGERS CEDEX 01
FRANCE

REFERENCE
86 A1 48 FB 00