

# Installation and Service Guide

1100 AND 1300  
CABINET



REFERENCE  
86 A1 91EM 03



# 1100 AND 1300 CABINET

# Installation and Service Guide

## **Hardware**

October 2006

BULL CEDOC  
357 AVENUE PATTON  
B.P.20845  
49008 ANGERS CEDEX 01  
FRANCE

REFERENCE  
86 A1 91EM 03

The following copyright notice protects this book under Copyright laws which prohibit such actions as, but not limited to, copying, distributing, modifying, and making derivative works.

Copyright © Bull SAS 1992, 2006

Printed in France

Suggestions and criticisms concerning the form, content, and presentation of this book are invited. A form is provided at the end of this book for this purpose.

To order additional copies of this book or other Bull Technical Publications, you are invited to use the Ordering Form also provided at the end of this book.

### **Trademarks and Acknowledgements**

We acknowledge the right of proprietors of trademarks mentioned in this book.

Intel® and Itanium® are registered trademarks of Intel Corporation.

Windows® and Microsoft software® are registered trademarks of Microsoft Corporation.

UNIX® is a registered trademark in the United States of America and other countries licensed exclusively through the Open Group.

Linux® is a registered trademark of Linus Torvalds.

*The information in this document is subject to change without notice. Bull will not be liable for errors contained herein, or for incidental or consequential damages in connection with the use of this material.*

---

# Preface

---

## Table of Contents

---

Intended Readers .....	vii
Highlighting .....	vii
Unpacking Label .....	viii
<b>Chapter 1. Overview .....</b>	<b>1-1</b>
Cabinet Models .....	1-2
1300H Cabinet and 1300H-E Cabinet .....	1-3
1100H Cabinet and 1100H-E Cabinet .....	1-4
1300L Cabinet and 1300L-E Cabinet .....	1-5
1100L Cabinet and 1100L-E Cabinet .....	1-6
PDU Models .....	1-7
PDU-4-2-M-63A .....	1-8
PDU-2-4-M-32A .....	1-9
PDU-0-7-M-32A .....	1-10
PDU-0-12-M-32A .....	1-11
<b>Chapter 2. Installing and Servicing Cabinets .....</b>	<b>2-1</b>
General Recommendations .....	2-2
Cabinet Packing .....	2-3
Inspecting Packing .....	2-4
Removing Packing .....	2-5
Storing Packing Items .....	2-5
Inspecting the Cabinet .....	2-6
Unloading the Cabinet .....	2-7
Service Clearance .....	2-7
Removing the Shipping Pallet Assembly .....	2-8
Moving the Cabinet .....	2-14
Rolling the Cabinet .....	2-14
Hoisting the Cabinet .....	2-15
Securing the Cabinet .....	2-16
Lowering the Jacking Screws .....	2-16
Installing the Stabilizer .....	2-17
Raising the Stabilizer .....	2-19
Lowering the Stabilizer .....	2-19
Removing / Installing Cabinet Doors and Covers .....	2-20
Removing / Installing the Front and Rear Doors .....	2-20
Removing the Door .....	2-20
Installing the Door .....	2-21
Removing / Installing Side Covers .....	2-22
Removing a Side Cover .....	2-22
Installing a Side Cover .....	2-23
Removing / Installing the 1300H/1100H Top Cover .....	2-24
Removing the Top Cover (1300H/1100H) .....	2-24
Installing the Top Cover (1300H/1100H) .....	2-25
Removing / Installing the 1300L/1100L Top Cover .....	2-26
Removing the 1300L/1100L Top Cover .....	2-26
Installing the 1300L/1100L Top Cover .....	2-27

Turning the Front and/or Rear Door .....	2-28
Adding an Extension Cabinet .....	2-29
Preparing the Cabinets .....	2-29
Fitting Front Spacers .....	2-29
Fitting Rear Spacers .....	2-30
Fitting the Top Spacer .....	2-31
Replacing Side Covers .....	2-31
Installing Servers and/or Devices .....	2-32
Checking Server / Device Compatibility .....	2-33
Fitting a Short Integration Kit .....	2-34
Fitting Equipment Trays .....	2-37
Fitting a Short Equipment Tray .....	2-38
Fitting a Medium Equipment Tray .....	2-39
Fitting a Long Equipment Tray .....	2-40
Mounting the Long Equipment Tray Integration Bracket .....	2-40
Fitting the Long Equipment Tray for Non-Rackable Devices .....	2-41
Fitting the Long Equipment Tray for Rackable Devices .....	2-42
Installing a PDU .....	2-44
<b>Chapter 3. Managing Power and Data Cables .....</b>	<b>3-1</b>
Routing Data Cables .....	3-2
Routing Inter-Cabinet Data Cables .....	3-2
Routing and Connecting Power Cables .....	3-3
Connecting a PDU to the Site Power Supply .....	3-3
Safety Recommendations .....	3-3
Mounting the PDU Power Cable Socket .....	3-4
<b>Appendix A. Specifications .....</b>	<b>A-1</b>
1300H Cabinet / 1300H-E Cabinet Specifications .....	A-2
1100H Cabinet / 1100H-E Cabinet Specifications .....	A-4
1300L Cabinet / 1300L-E Cabinet Specifications .....	A-6
1100L Cabinet / 1100L-E Cabinet Specifications .....	A-8
PDU-4-2-M-63A Specifications .....	A-10
PDU-2-4-M-32A .....	A-11
PDU-0-7-M-32A .....	A-12
PDU-0-12-M-32A .....	A-13
<b>Appendix B. Regulatory Statements and Disclaimers .....</b>	<b>B-1</b>
Declaration of the Manufacturer or Importer .....	B-1
Safety Compliance Statement .....	B-1
European Community (EC) Council Directives .....	B-1
Federal Communications Commission (FCC) Statement .....	B-2
FCC Declaration of Conformity .....	B-2
Canadian Compliance Statement (Industry Canada) .....	B-2
Laser Compliance Notice .....	B-2
<b>Appendix C. Safety Notices .....</b>	<b>C-1</b>
Definition of Safety Notices .....	C-1
General Safety Notices .....	C-2
Electrical Safety Notices .....	C-3
<b>Index .....</b>	<b>X-1</b>

---

## List of Figures

Figure 1.	Unpacking label	viii
Figure 2.	1300H Cabinet / 1300H-E Cabinet features	1-3
Figure 3.	1100H Cabinet / 1100H-E Cabinet features	1-4
Figure 4.	1300L Cabinet / 1300L-E Cabinet features	1-5
Figure 5.	1100L Cabinet / 1100L-E Cabinet features	1-6
Figure 6.	PDU-4-2-M-63A features - vertical / horizontal installation	1-8
Figure 7.	PDU-2-4-M-32A features -vertical / horizontal installation	1-9
Figure 8.	PDU-0-7-M-32A features - vertical / horizontal installation	1-10
Figure 9.	PDU-0-12-M-32A features - vertical/horizontal installation	1-11
Figure 10.	Packing shockwatch and tiltwatch labels	2-4
Figure 11.	Removing the top, front and rear covers	2-5
Figure 12.	Required unpacking area	2-7
Figure 13.	Removing shipping brackets	2-8
Figure 14.	Pallet assembly	2-9
Figure 15.	Removing pallet retaining plates	2-9
Figure 16.	Positioning the fork lift - front	2-10
Figure 17.	Removing the front half-pallet	2-10
Figure 18.	Skate-board assembly	2-11
Figure 19.	Inserting the skate-board	2-11
Figure 20.	Tightening the skate-board safety screw	2-11
Figure 21.	Positioning the fork lift - rear	2-12
Figure 22.	Removing the rear half-pallet	2-12
Figure 23.	Installing the rear jack screws	2-13
Figure 24.	Cabinet on casters	2-13
Figure 25.	Single cabinet service clearance	2-14
Figure 26.	Dual cabinet service clearance	2-15
Figure 27.	Installing hoisting fixtures.	2-15
Figure 28.	Lowering jacking screws	2-16
Figure 29.	Stabilizer and fixtures	2-17
Figure 30.	Removing the front shipping bracket	2-17
Figure 31.	Aligning the stabilizer	2-18
Figure 32.	Stabilizer cut-outs	2-18
Figure 33.	Installing the stabilizer trim	2-19
Figure 34.	Raising the stabilizer	2-19
Figure 35.	Removing the door	2-20
Figure 36.	Installing the door	2-21
Figure 37.	Opening side cover locks	2-22
Figure 38.	Side cover retaining lug	2-22
Figure 39.	Side cover retaining lug	2-23
Figure 40.	Closing side cover locks	2-23
Figure 41.	Unscrewing the top cover	2-24
Figure 42.	Removing the top cover	2-24
Figure 43.	Installing the top cover (1300H/1100H)	2-25
Figure 44.	Securing the top cover (1300H/1100H)	2-25
Figure 45.	Removing the top cover (1300L/1100L)	2-26
Figure 46.	Installing the top cover (1300L/1100L)	2-27

Figure 47. Fitting a front spacer .....	2-29
Figure 48. Fitting a rear spacer .....	2-30
Figure 49. Fitting the top spacer .....	2-31
Figure 50. Internal cabinet dimensions .....	2-33
Figure 51. Mounting flange hole size and placement .....	2-34
Figure 52. Fitting a 1U integration bracket .....	2-35
Figure 53. Fitting a 2U integration bracket .....	2-35
Figure 54. 2U and 1U integration brackets .....	2-36
Figure 55. Mounting flange hole size and placement .....	2-37
Figure 56. Fitting a short equipment tray .....	2-38
Figure 57. Fitting a medium equipment tray .....	2-39
Figure 58. Mounting the long equipment tray integration bracket .....	2-40
Figure 59. Fitting the long equipment tray for non-rackable devices .....	2-41
Figure 60. Fitting the long equipment tray for rackable devices .....	2-42
Figure 61. Installing long equipment tray leveling pads .....	2-43
Figure 62. Installing a PDU vertically .....	2-44
Figure 63. Installing a PDU horizontally .....	2-45
Figure 64. Power plug and socket .....	3-3
Figure 65. PDU power socket .....	3-4

---

## List of Tables

Table 1. 1300H Cabinet / 1300H-E Cabinet Specifications .....	A-3
Table 2. 1100H Cabinet / 1100H-E Cabinet .....	A-5
Table 3. 1300L Cabinet / 1300L-E Cabinet Specifications .....	A-7
Table 4. 1100L Cabinet / 1100L-E Cabinet .....	A-9
Table 5. PDU-4-2-M-63A specifications .....	A-10
Table 6. PDU-2-4-M-32A specifications .....	A-11
Table 7. PDU-0-7-M-32A specifications .....	A-12
Table 8. PDU-0-12-M-24A specifications .....	A-13



---

## Intended Readers

This guide is intended for use by qualified personnel in charge of installing and servicing Bull 1300H/L & 1100H/L Cabinets.



### Important:

**Detailed installation and servicing instructions for rack-mountable servers and/or devices are provided in the documentation delivered with these servers and/or devices.**

Chapter 1. Overview  
describes cabinet features.

Chapter 2. Installing and Servicing Cabinets  
explains how to unpack, install, and service the cabinets.

Chapter 3. Managing Power and Data Cables  
explains how to route and connect power and data cables inside the cabinets.

Appendix A. Specifications

Appendix B. Regulatory Statements and Disclaimers

Appendix C. Safety Notices



### DANGER

**Personnel are requested to carefully read the Safety Notices set out in Appendix C. before installing or servicing cabinets.**

---

## Highlighting

The following highlighting conventions are used in this guide:

<b>Bold</b>	Identifies predefined commands, subroutines, keywords, files, structures, buttons, labels, and icons.
<i>Italics</i>	Identifies referenced publications, chapters, sections, figures, and tables.
< >	Identifies parameters to be supplied by the user.

# Unpacking Label

<b>UNPACKING LABEL</b> <b>(ETIQUETTE DEPALETTISATION)</b>	
<b>OPEN THE UNPACKING BOX</b> - Tools (1 phillips screwdriver, 2 allen wrenches) - 2 skate-boards & 2 safety screws - 2 stabilizing jacks	<b>OUVRIER LA CAISSE DE DEPALETTISATION</b> - Outils (1 Tournevis cruciforme, 2 clé allen) - 2 « skate-boards » & 2 vis de sécurité - 2 vérins stabilisateurs
<b>1. Remove front and rear shipping brackets.</b> <i>(Retirer les équerres de transport)</i>	<b>2. Remove left and right pallet retaining plates</b> <i>(Retirer les plaques de maintien de la planche)</i>
<b>3. Remove the central board</b> <i>(Retirer la planche)</i>	<b>4. Position the fork lift and raise by 1 to 2 cm</b> <i>(Positionner le transpalette et lever de 1 à 2 cm)</i>
<b>5. Remove the 2 half pallets</b> <i>(Retirer les 2 demi-palettes)</i>	<b>6. Insert the skate-boards, as indicated by the arrows</b> <i>(Glisser les « skate-boards » en respectant le sens des flèches)</i>
<b>7. Install the 2 stabilizing jacks</b> <i>(Mettre les deux vérins stabilisateurs)</i>	<b>8. Insert a safety screw in each skate-board to secure</b> <i>(Mettre une vis de sécurité par « skate-board » pour les verrouiller)</i>
Remove the fork lift to rest the cabinet on the casters <i>(Retirer le transpalette pour poser la baie sur ses roulettes)</i>	
<b>76680016-002</b>	

Figure 1. Unpacking label

---

## Chapter 1. Overview

This chapter presents the different cabinet and power distribution unit models. It includes the following topics:

- 1300H Cabinet and 1300H-E Cabinet, on page 1-3
- 1100H Cabinet and 1100H-E Cabinet, on page 1-4
- 1300L Cabinet and 1300L-E Cabinet, on page 1-5
- 1100L Cabinet and 1100L-E Cabinet, on page 1-6
- PDU-4-2-M-63A, on page 1-8
- PDU-2-4-M-32A, on page 1-9
- PDU-0-7-M-32A, on page 1-10
- PDU-0-12-M-32A, on page 1-11

---

## Cabinet Models

Four main cabinet models and four extension cabinet models are available:

### Main Cabinet Models

1300H Cabinet

1100H Cabinet

1300L Cabinet

1100L Cabinet

### Extension Cabinet Models

1300H-E Cabinet

1100H-E Cabinet

1300L-E Cabinet

1100L-E Cabinet



**Note:**

See Appendix A. Specifications for further details.

## 1300H Cabinet and 1300H-E Cabinet

The 1300H Cabinet and 1300H-E Cabinet are 600 mm wide, 40-U high, 1300 mm deep cabinets.

The 1300H Cabinet and 1300H-E Cabinet allow the installation of both short and long server and device drawers. Refer to the documentation delivered with the server and/or device drawer for detailed installation instructions.

The 1300H Cabinet is delivered with side panels installed. The 1300H-E Cabinet is delivered with or without side panels installed, according to required suite configuration.

### Note:

- 1 U = 44.45 mm (1.75 in)
- Maximum allowable thermal dissipation: 400 W per U mean, 700 W per U peak

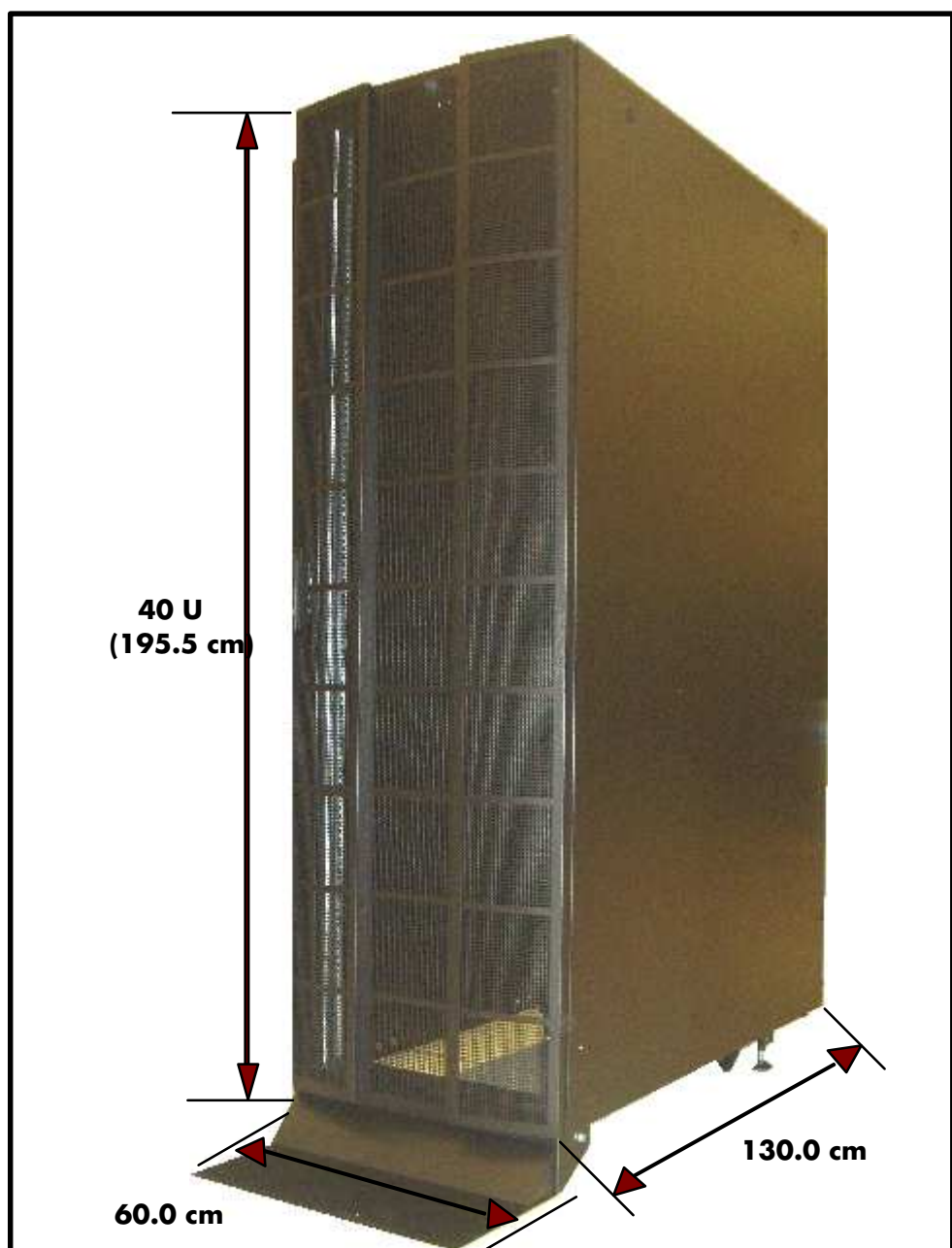

Figure 2. 1300H Cabinet / 1300H-E Cabinet features

## 1100H Cabinet and 1100H-E Cabinet

The 1100H Cabinet and 1100H-E Cabinet are 600 mm wide, 40-U high, 1100 mm deep cabinets.

The 1100H Cabinet and 1100H-E Cabinet allow the installation of short server and device drawers only. Refer to the documentation delivered with the server and/or device drawer for detailed installation instructions.

The 1100H Cabinet is delivered with side panels installed. The 1100H-E Cabinet is delivered with or without side panels, according to required suite configuration.

### Note:

- 1 U = 44.45 mm (1.75 in)
- Maximum allowable thermal dissipation: 400 W per U mean, 700 W per U peak

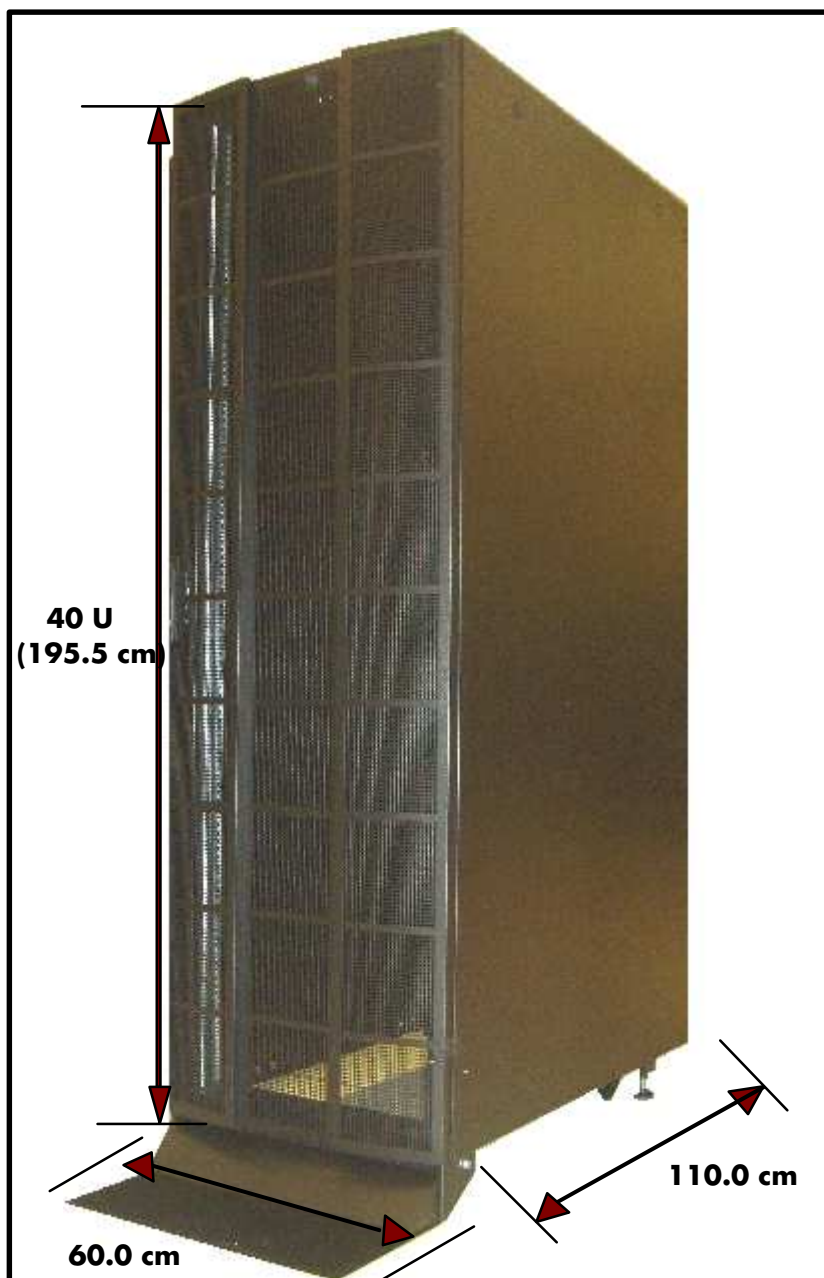

Figure 3. 1100H Cabinet / 1100H-E Cabinet features

## 1300L Cabinet and 1300L-E Cabinet

The 1300L Cabinet and 1300L-E Cabinet are 600 mm wide, 19-U high, 1300 mm deep cabinets.

The 1300L Cabinet and 1300L-E Cabinet allow the installation of both short and long server and device drawers. Refer to the documentation delivered with the server and/or device drawer for detailed installation instructions.

The 1300L Cabinet is delivered with side panels installed. The 1300L-E Cabinet is delivered with or without side panels, according to required suite configuration.

### Note:

- 1 U = 44.45 mm (1.75 in)
- Maximum allowable thermal dissipation: 400 W per U mean, 700 W per U peak

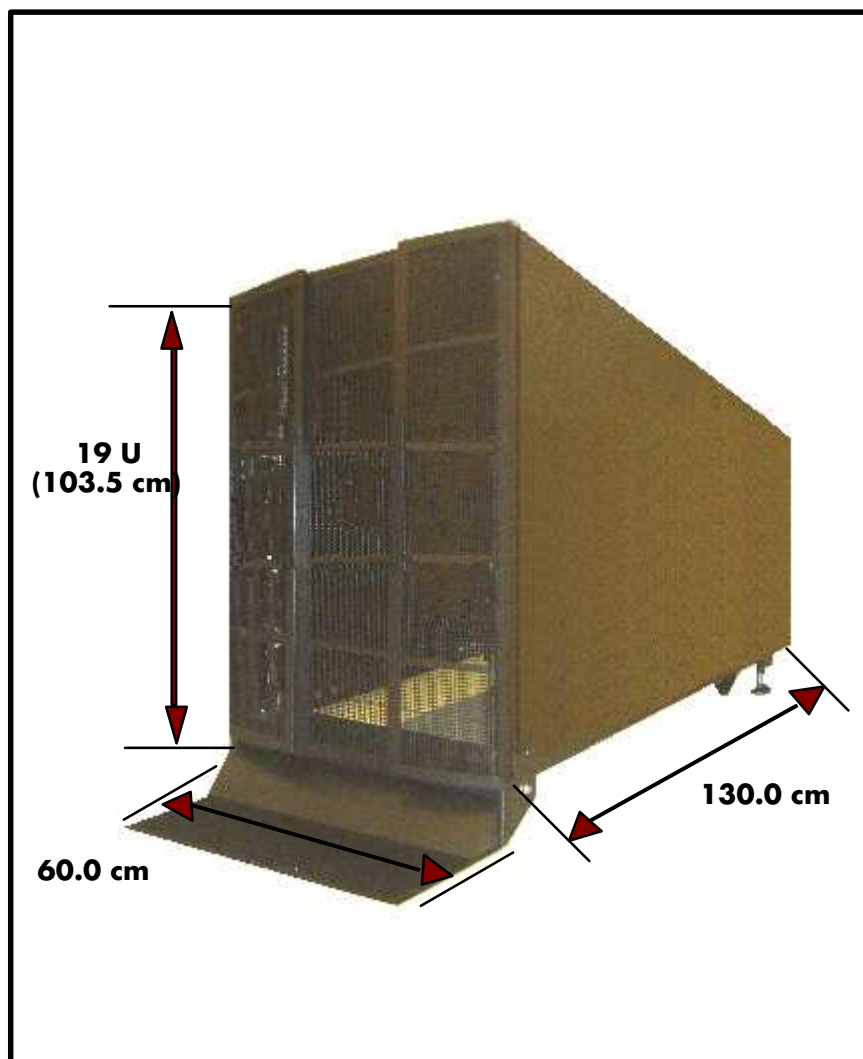

Figure 4. 1300L Cabinet / 1300L-E Cabinet features

## 1100L Cabinet and 1100L-E Cabinet

The 1100L Cabinet and 1100L-E Cabinet are 600 mm wide, 19-U high, 1100 mm deep cabinets.

The 1100L Cabinet and 1100L-E Cabinet allow the installation of short server and device drawers. Refer to the documentation delivered with the server and/or device drawer for detailed installation instructions.

The 1100L Cabinet is delivered with side panels installed. The 1100L-E Cabinet is delivered with or without side panels, according to required suite configuration.

 **Note:**

- 1 U = 44.45 mm (1.75 in)
- Maximum allowable thermal dissipation: 400 W per U mean, 700 W per U peak

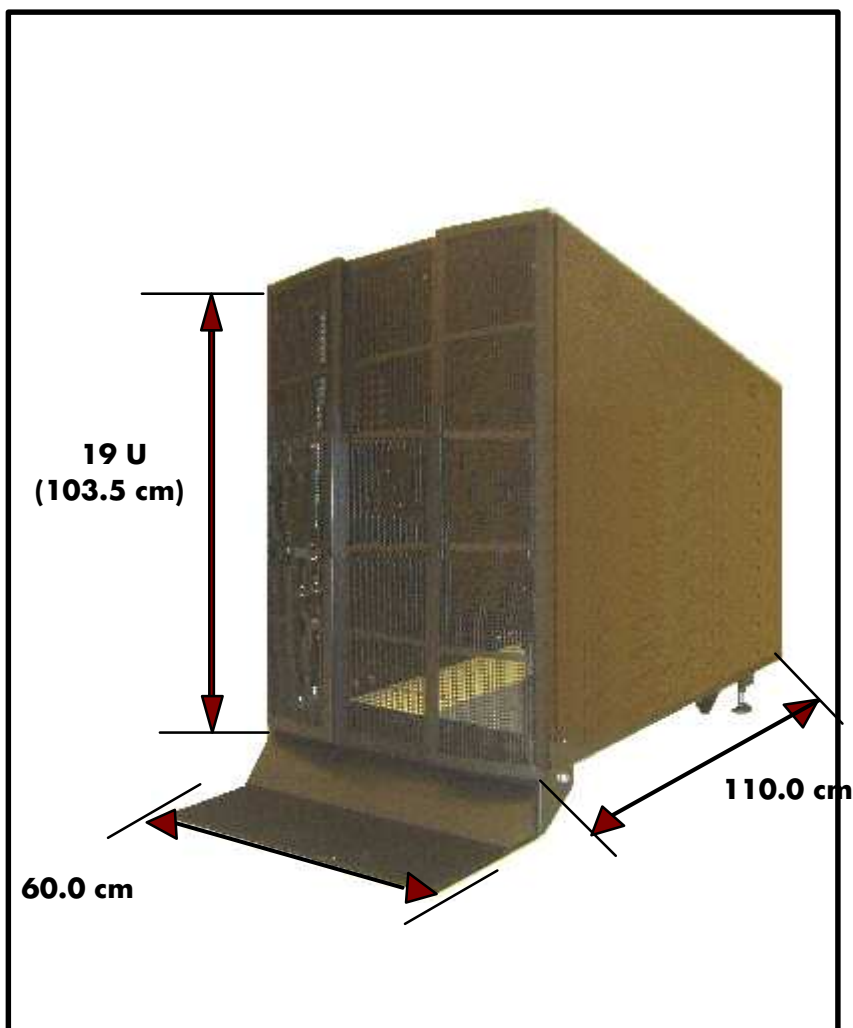

Figure 5. 1100L Cabinet / 1100L-E Cabinet features



---

## PDU Models

Three Power Distribution Units (PDUs) are available:

- **PDU-4-2-M-63A**
- **PDU-2-4-M-32A**
- **PDU-0-7-M-32A**
- **PDU-0-12-M-32A**

According to type, the PDUs allow you to connect six, seven, or twelve servers and/or devices to a single dedicated power supply outlet.

All PDUs can be installed both vertically and horizontally in the cabinet. Refer to the documentation delivered with the PDU for detailed installation instructions.



**Note:**

See **Appendix A. Specifications** for further details.

## PDU-4-2-M-63A

The PDU-4-2-M-63A allows you to connect up to six servers and/or devices. It offers the following features:

- Phase: Single phase
- Max. Current: 63 A
- Max. Voltage: 240 VAC
- 14.5A (C19) Outlets: 4
- 9A (C13) Outlets: 2
- Mains Cable: 3xAWG06
- Mains Connectors: IEC60309-63A



### CAUTION:

France:

**Power sockets and plugs must be compliant with Decree 88-1056 Article 20-IV, dated 14th November 1988.**

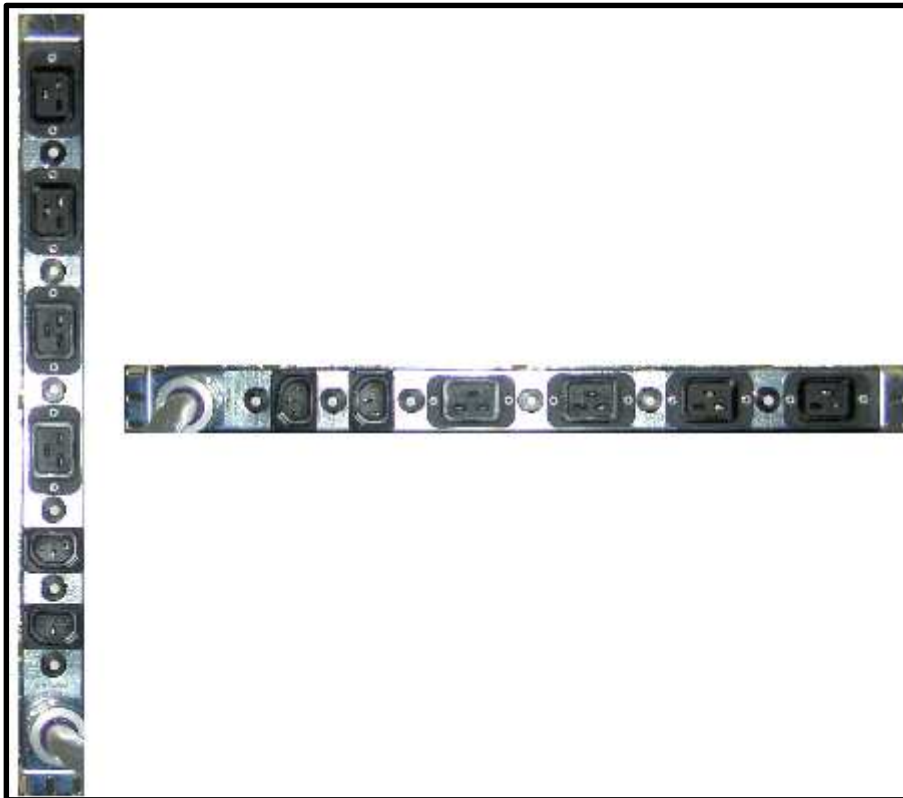

Figure 6. PDU-4-2-M-63A features - vertical / horizontal installation

## PDU-2-4-M-32A

The PDU-2-4-M-32A allows you to connect up to six servers and/or devices. It offers the following features:

- Phase: Single phase
- Max. Current: 32 A
- Max. Voltage: 240 VAC
- 14.5A (C19) Outlets: 2
- 9A (C13) Outlets: 4
- Mains Cable: 3xAWG10
- Mains Connectors: IEC60309-32A

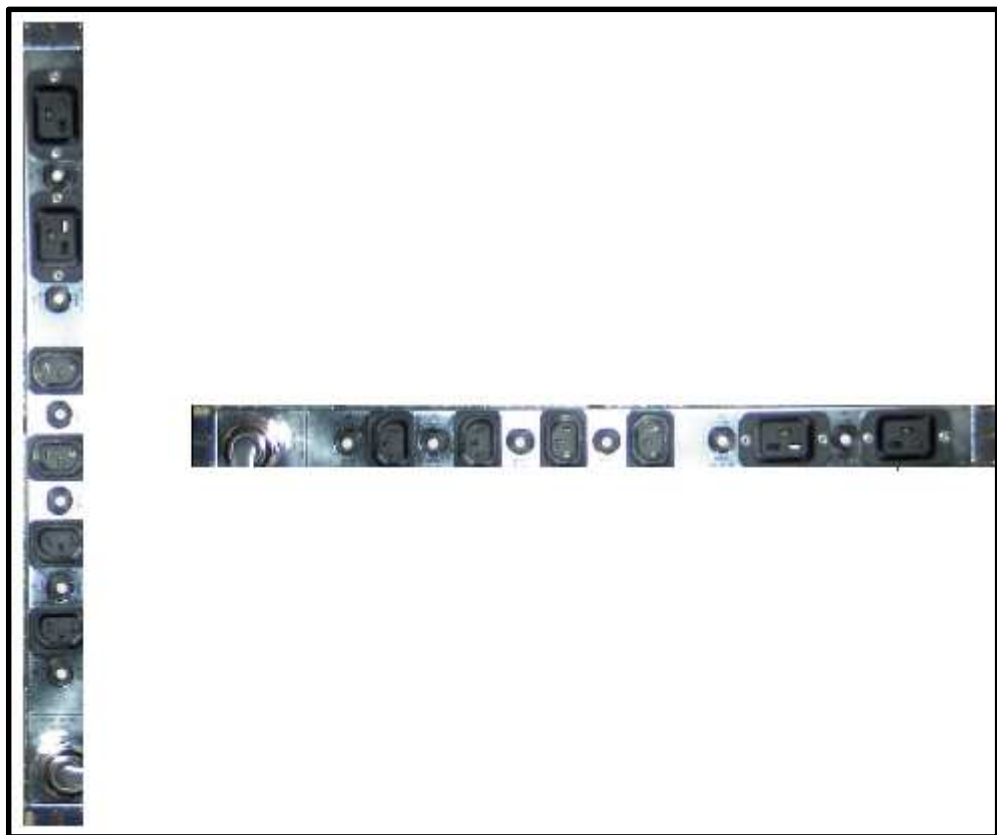

Figure 7. PDU-2-4-M-32A features -vertical / horizontal installation

## PDU-0-7-M-32A

The PDU-0-7-M-32A allows you to connect up to seven servers and/or devices. It offers the following features:

- Phase: Single phase
- Max. Current: 32 A
- Max. Voltage: 240 VAC
- 14.5A (C19) Outlets: 0
- 9A (C13) Outlets: 7
- Mains Cable: 3xAWG10
- Mains Connectors: IEC60309-32A

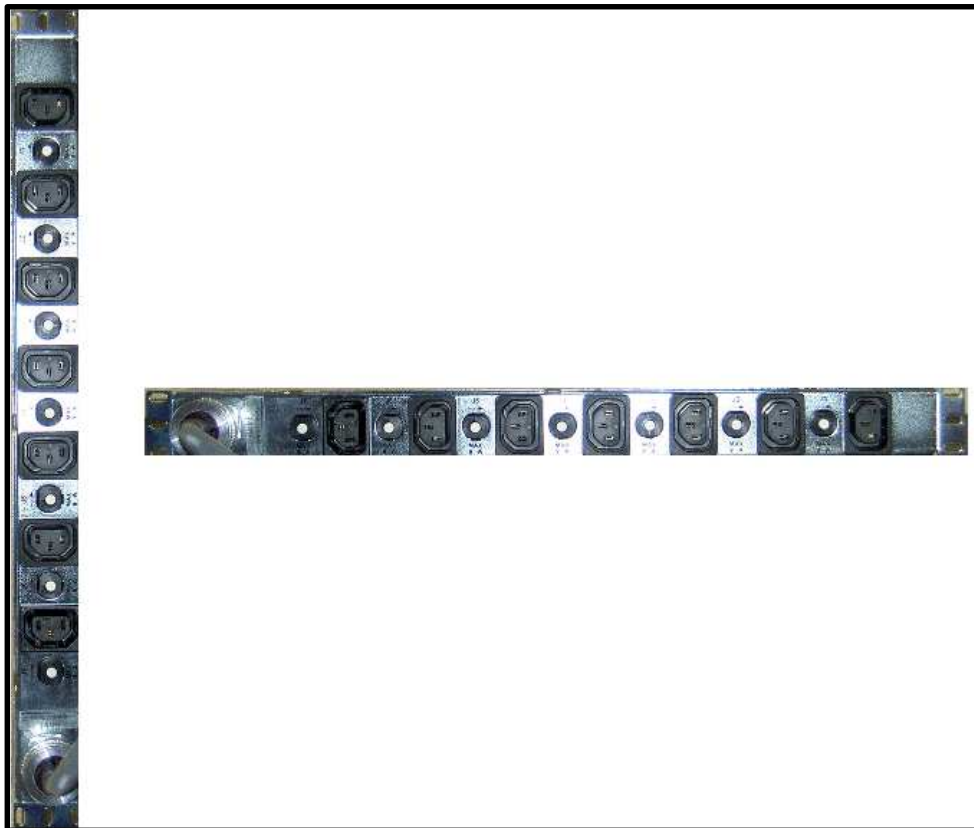

Figure 8. PDU-0-7-M-32A features - vertical / horizontal installation

## PDU-0-12-M-32A

The PDU-0-12-M-32A allows you to connect up to twelve servers and/or devices. It offers the following features:

- Phase: Single phase
- Max. Current: 32 A
- Max. Voltage: 240 VAC
- 14.5A (C19) Outlets: 0
- 9A (C13) Outlets: 12
- Mains Cable: 3xAWG10
- Mains Connectors: IEC60309-32A

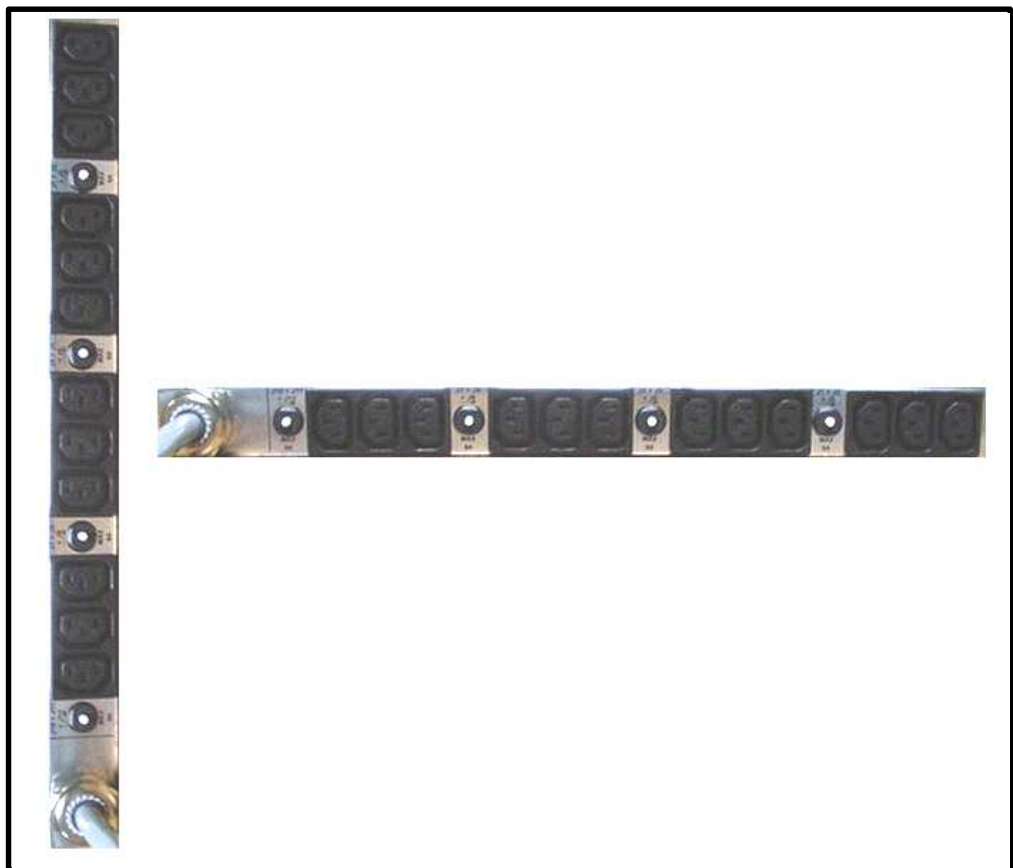

Figure 9. PDU-0-12-M-32A features - vertical/horizontal installation



---

## Chapter 2. Installing and Servicing Cabinets

This chapter explains how to unpack, install, and service the cabinets. It includes the following topics:

- General Recommendations, on page 2-2
- Inspecting Packing, on page 2-4
- Removing Packing, on page 2-5
- Storing Packing Items, on page 2-5
- Inspecting the Cabinet, on page 2-6
- Unloading the Cabinet, on page 2-7
- Moving the Cabinet, on page 2-14
- Securing the Cabinet, on page 2-16
- Removing / Installing the Front and Rear Doors, on page 2-20
- Removing / Installing Side Covers, on page 2-22
- Removing / Installing the 1300H/1100H Top Cover, on page 2-24
- Removing / Installing the 1300L/1100L Top Cover, on page 2-26
- Turning the Front and/or Rear Door, on page 2-28
- Adding an Extension Cabinet, on page 2-29
- Installing Servers and/or Devices, on page 2-32
- Checking Server / Device Compatibility, on page 2-33
- Fitting a Short Integration Kit, on page 2-34
- Installing a PDU, on page 2-44



**CAUTION:**

**All servers and devices installed in the cabinets must be compliant with national safety regulations.**

---

## General Recommendations

Bull 1300H/L & 1100H/L Cabinets may be delivered either equipped with servers and devices or empty, according to Customer requirements.

Site preparation must be completed by the pre-arranged delivery date. Any delay due to non-completion of the site by the pre-arranged date will be considered as the Customer's responsibility.

Servers may be delivered 24 hours in advance of the scheduled installation date. On arrival, they should be placed, in their packing, in the Computer Room so that they reach room temperature before powering up.



**CAUTION:**

**It is mandatory for equipped cabinets to be transported vertically. Equipped cabinets may be extremely heavy and require the use of an elevator. The Data Processing Site manager must allocate enough personnel to ensure safe handling.**

**See Appendix A. in this guide and the documentation delivered with servers and/or devices for specifications.**

Use the Packing Slip to check the number and condition of the shipping boxes prior to unpacking.



**Warning:**

**To avoid condensation and incorrect handling, cabinets must be removed from their packing by authorized Service personnel ONLY, on the scheduled installation date.**



---

## Cabinet Packing

Cabinets are delivered on two half-pallets for easy unloading. The Data Processing Site manager must set aside the required working area for unpacking as shown in Figure 12, on page 2-7.

The following packing items are used to protect cabinets during shipping:

- top, front, rear protective covers,
- two half-pallets,
- one central support board,
- plastic and velcro straps,
- shockwatch and tiltwatch labels.

Two boxes, labeled **Unpacking Box** and **Open Me First** are delivered with each cabinet. These boxes contain:

### Unpacking Box

- two skate-boards and two safety screws,
- two rear stabilizing jack screws,
- tools.

### Open Me First

- one front stabilizer and fixtures (optional),
- hoisting fixtures (optional),
- this document.

See Appendix A. Specifications for cabinet packing details.

## Inspecting Packing

Before unpacking, check the indicators on the 2 shockwatch and 3 tiltwatch labels, positioned as follows on the packing:

### Shockwatch labels

- 1 on the front cover
- 1 on the outer side of the internal front door cover

### Tiltwatch labels

- 1 on the front cover
- 1 on the side cover
- 1 on the outer side of the internal front door cover

If one or more of the indicators are RED, the cabinet and/or contents may be damaged. Note indicator status on the bill of lading and carefully inspect the cabinet and contents before powering up servers and devices.

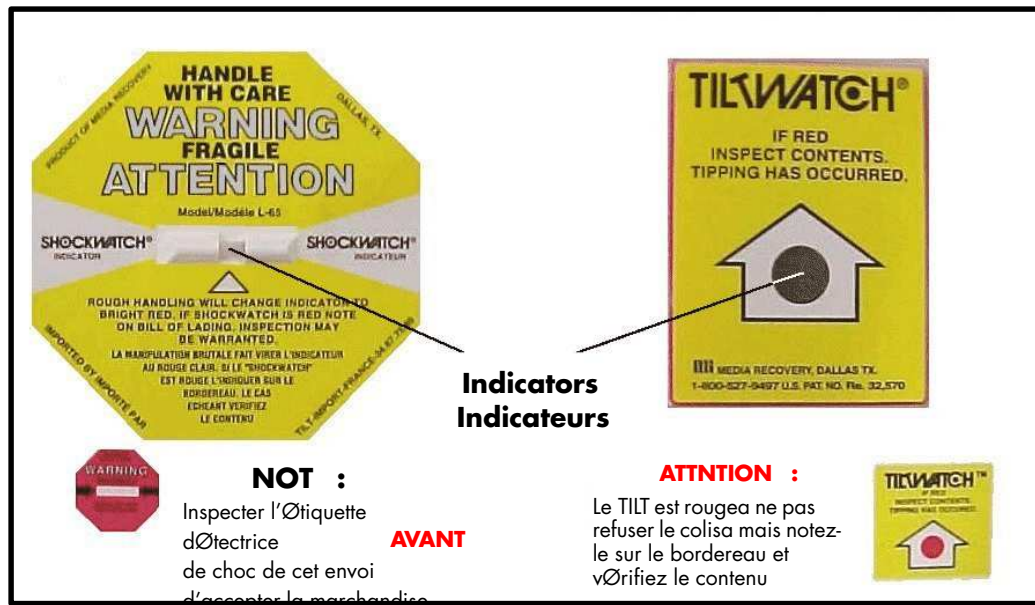

NOTE:	ATTENTION:
Check the Shockwatch label BEFORE accepting the merchandise.	If the Tiltwatch label is red make a reserve on the delivery slip and check packing contents.

Figure 10. Packing shockwatch and tiltwatch labels

## Removing Packing

### Tools Required

- Cutter



Figure 11. Removing the top, front and rear covers

1. Cut the plastic straps with the cutter.
2. Remove the top cover.
3. Remove the rear and front covers by opening the plastic fasteners.
4. Unfasten and remove the stoppers surrounding the cabinet.
5. Remove the stretch film / condensation barrier packing.

## Storing Packing Items

All packing items are to be stored in an ancillary room for re-use in the event of relocation or shipping.

---

## Inspecting the Cabinet

Once the cabinet has been unpacked, a preliminary visual inspection must be performed before it is unloaded from the shipping pallet.



### CAUTION:

#### Pre-equipped cabinets:

**If the inspection indicates an unacceptable safety condition, the condition must be corrected before powering up the server and/or devices inside the cabinet.**

1. Check that the delivery is compliant with the Purchase Order.
2. Check that the boxes labeled **Open Me First** and **Unpacking Box** contain the stabilizer and skate-board assemblies.
3. Check covers and doors for sharp edges, damage or alterations.
4. Check the correct fit of covers and doors.
5. Open the front and rear doors.



### Note:

Unlock the front door with the key, pull the handle forwards and upwards to disengage the lock.

6. Check for internal damage, alterations and obvious safety hazards such as broken wires, sharp edges, or broken insulation.
7. Check internal cables for damage.
8. Check for dirt, water, and any other form of contamination inside the cabinet.
9. Check the voltage label on the back of the cabinet to ensure that it matches the voltage at the power outlet.
10. Check external power cables for damage.
11. Check correct closure of front and rear doors.

## Unloading the Cabinet

The cabinet is delivered on two half-pallets for easy unloading with a fork lift.

### Service Clearance

The Data Processing Site manager must set aside the required working area for unpacking as shown in the following figure.

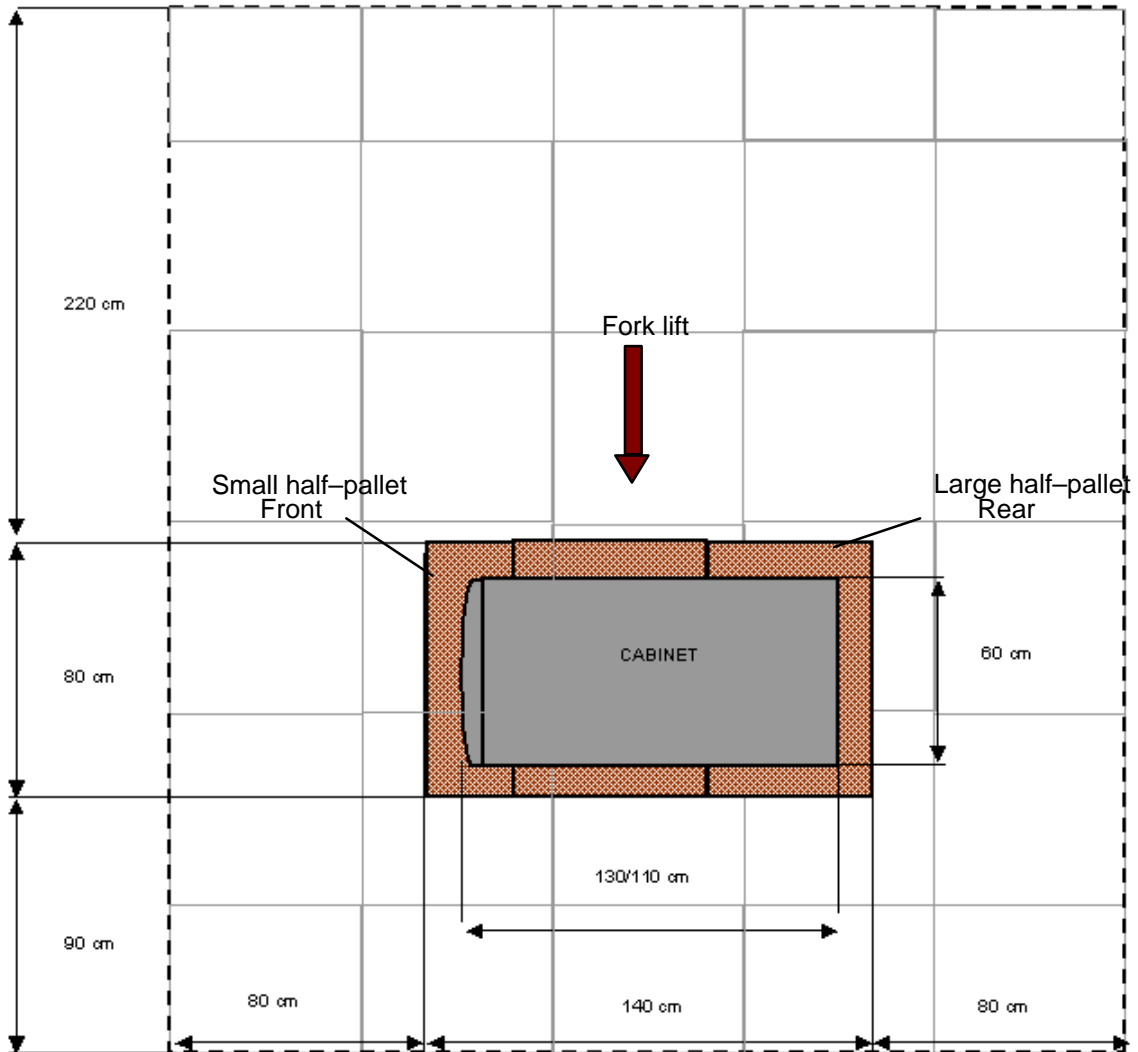

#### Note:

Cabinet depth:

130 cm

\* Fork lift pick-up area:

76.5 cm

Cabinet depth:

110 cm

\* Fork lift pick-up area:

58 cm

Figure 12. Required unpacking area

## Removing the Shipping Pallet Assembly



### Important:

All packing items are to be stored in an ancillary room for re-use in the event of relocation or shipping.

Before proceeding to set up servers and/or devices, clear and clean the installation area.

### Tools Required

- Fork lift
- Phillips screwdriver
- Allen wrench
- Skate boards and safety screws
- Rear stabilizing jacks



### CAUTION:

To ensure that the cabinet remains stable, two people are required to safely remove the shipping pallet.

1. Open the front and rear doors.
2. Check that the boxes labeled **Unpacking Box** and **Open Me First** contain the stabilizer and skate-board assemblies.
3. Remove the front and rear shipping brackets securing the base of the cabinet to the pallet assembly and set aside.



Figure 13. Removing shipping brackets

4. Unscrew the four retaining plates securing the half-pallets to the central support board.

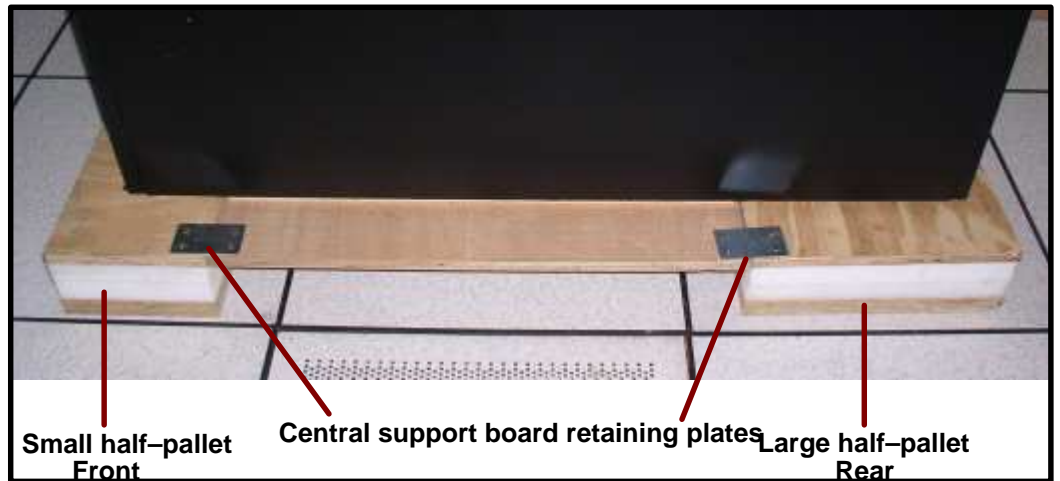

Figure 14. Pallet assembly



Figure 15. Removing pallet retaining plates

5. Firmly push down on both sides of the central support board to disengage from the half-pallets and remove.

6. From the **left-hand side** of the cabinet, line the fork lift up with the small front half-pallet and insert into place.

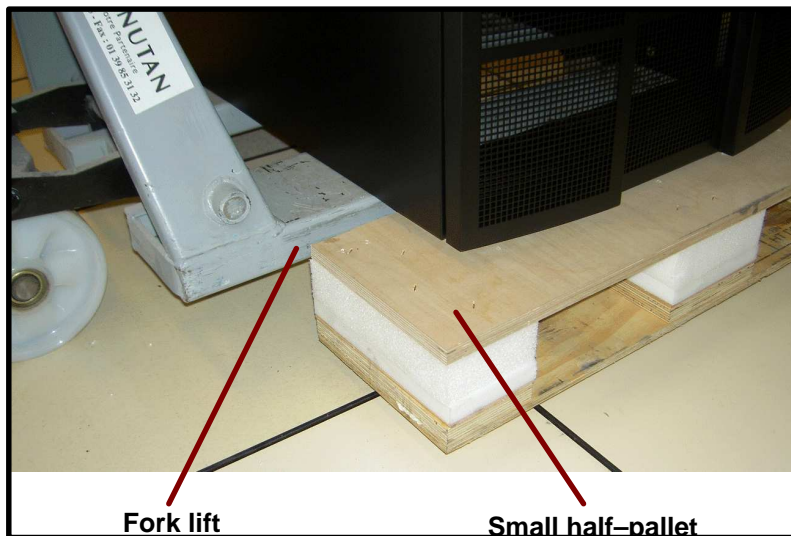

Figure 16. Positioning the fork lift - front

7. Gently raise the cabinet so that it is 1 cm or 2 cm clear of the front half-pallet.
8. Slide the front half-pallet free of the front cabinet guide-rails by pulling in the opposite direction to the fork lift.

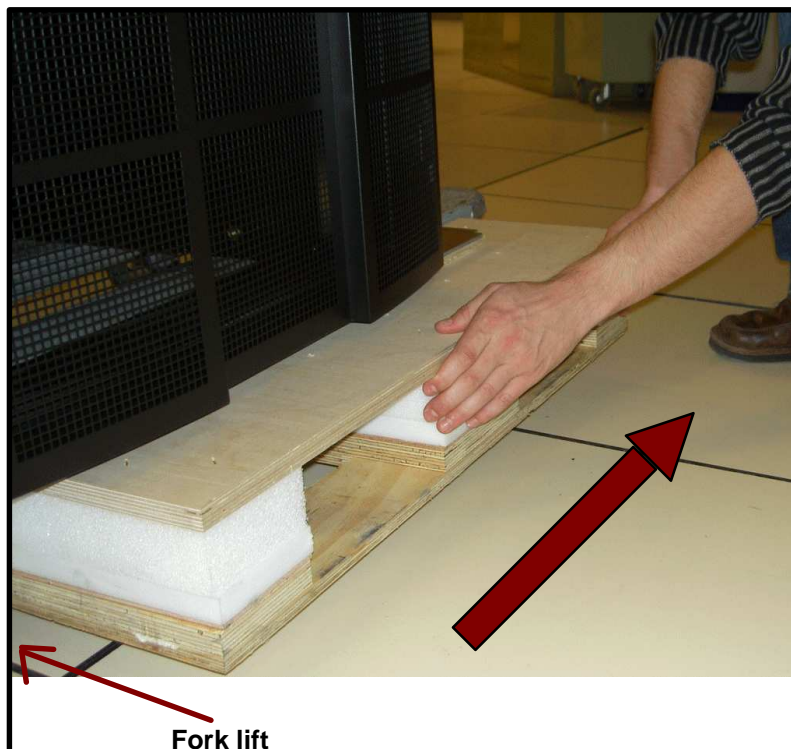

Figure 17. Removing the front half-pallet



9. Remove a skate-board assembly from the box labeled **Unpacking Box**.

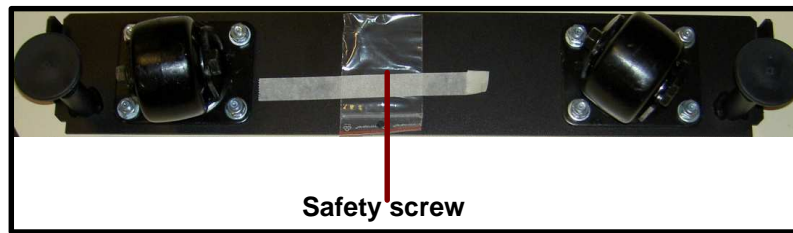

Figure 18. Skate-board assembly

10. Remove the skate-board safety screw from its packing, ready for use.  
11. Insert the skate-board in the front guide-rails and firmly push into place.



Figure 19. Inserting the skate-board

12. Insert the safety screw into the screw hole and tighten with the Allen wrench to secure the skate-board to the cabinet.

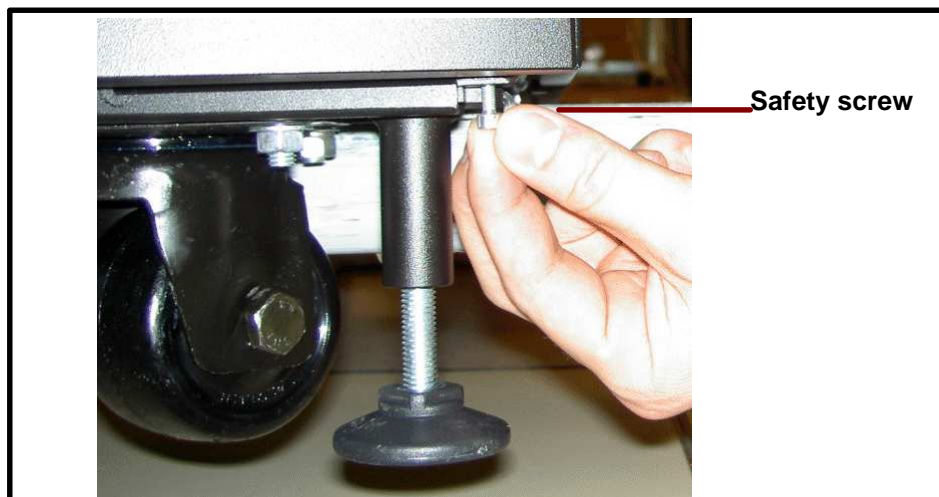

Figure 20. Tightening the skate-board safety screw

13. Remove the fork lift. The cabinet now rests on the front casters and the rear half-pallet.

14. From the **left-hand side** of the cabinet, line the fork lift up with the large rear half-pallet and insert into place.

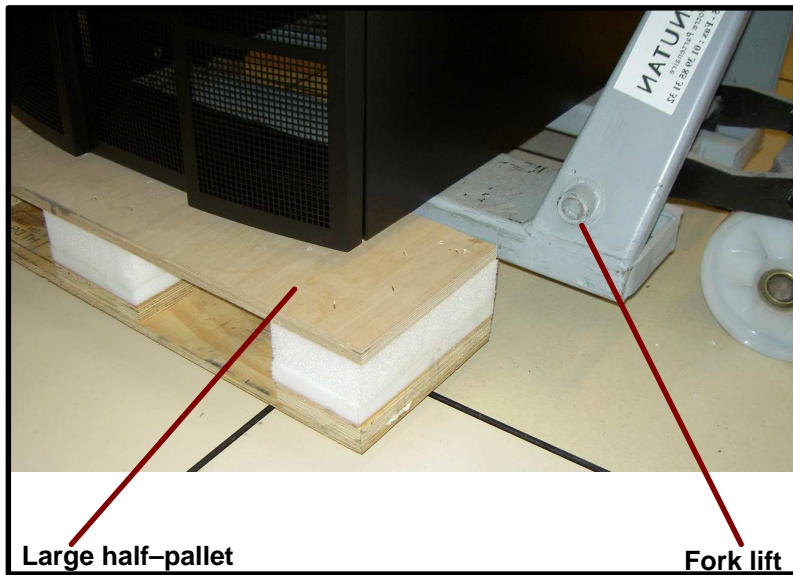

Figure 21. Positioning the fork lift - rear

15. Gently raise the cabinet so that it is 1 cm or 2 cm clear of the rear half-pallet.
16. Slide the rear half-pallet free of the rear cabinet guide-rails by pulling in the opposite direction to the fork lift.

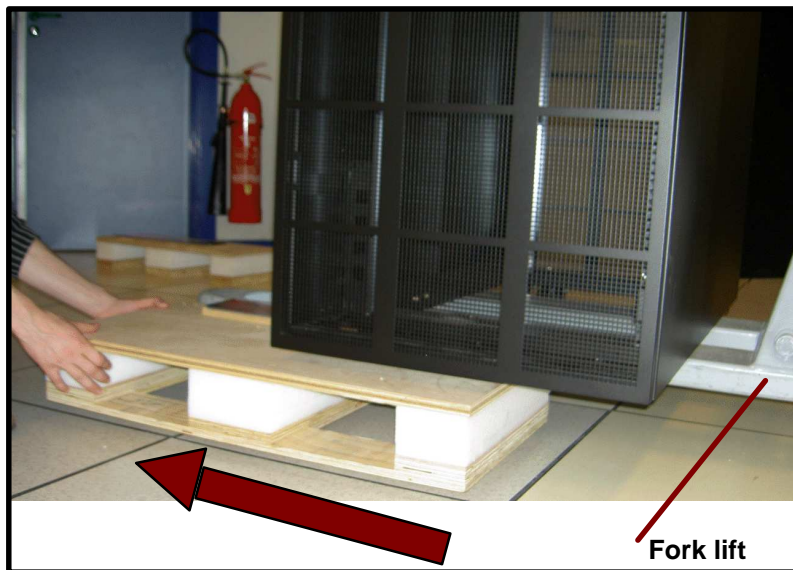

Figure 22. Removing the rear half-pallet

17. Repeat Steps 9 to 12 to install the rear skate-board.

18. Install the two rear jack screws, used to stabilize the cabinet, by screwing firmly into place.



Figure 23. Installing the rear jack screws

19. Remove the fork lift. The cabinet now rests on the front and rear casters.

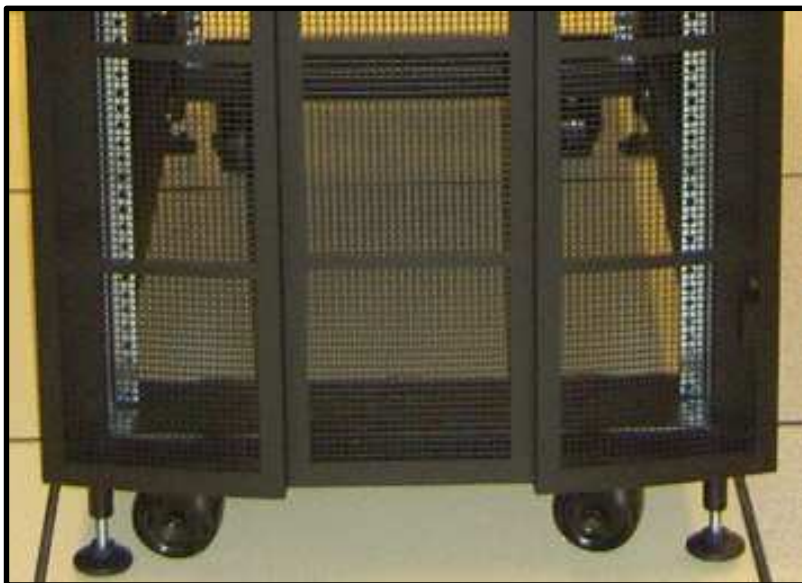

Figure 24. Cabinet on casters

20. Store packing items for re-use in the event of relocation or shipping.

## Moving the Cabinet

The cabinet is equipped with four swivel casters so that it can be easily rolled to the location indicated on the Customer's floor plan.

If required, the cabinet can be hoisted into place. See *Hoisting the Cabinet*, on page 2-15.



### CAUTION:

- Before moving the cabinet, it is **MANDATORY** to check that skate-board safety screws have been installed correctly. See Figure 20, on page 2-11.
- If the cabinet is pre-equipped with servers and/or devices, two people are required to roll it to the required location.

## Rolling the Cabinet

### Tools Required

- None

1. Check that the two front and four rear jacking screws are raised and allow the cabinet to move freely.
2. Carefully guide the cabinet to its location.
3. Check required service clearance at the rear, front and sides of the cabinet.
4. Take care to leave sufficient access to raised floor cable cut-outs.

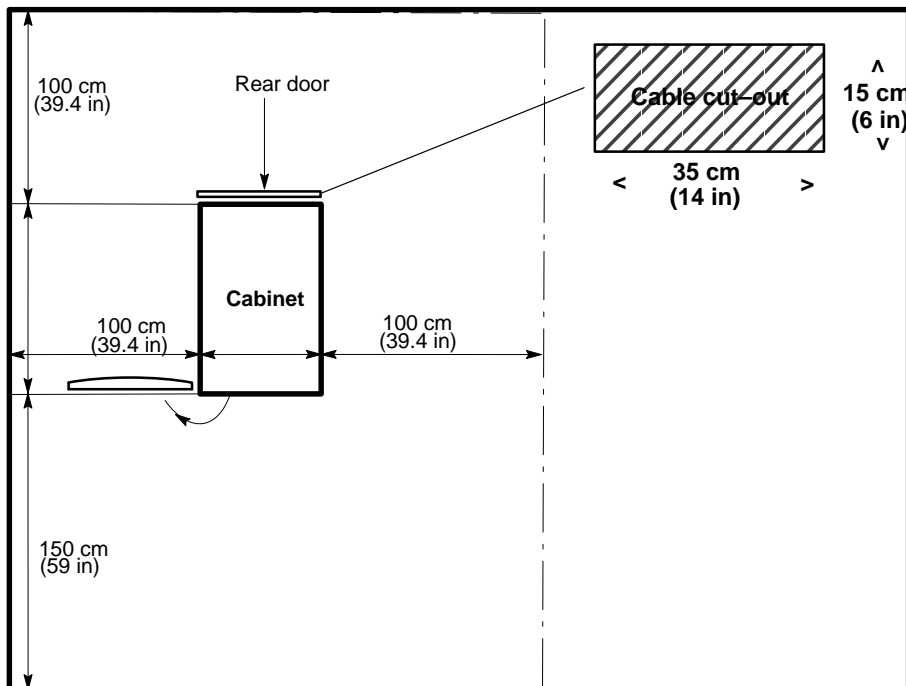

Figure 25. Single cabinet service clearance

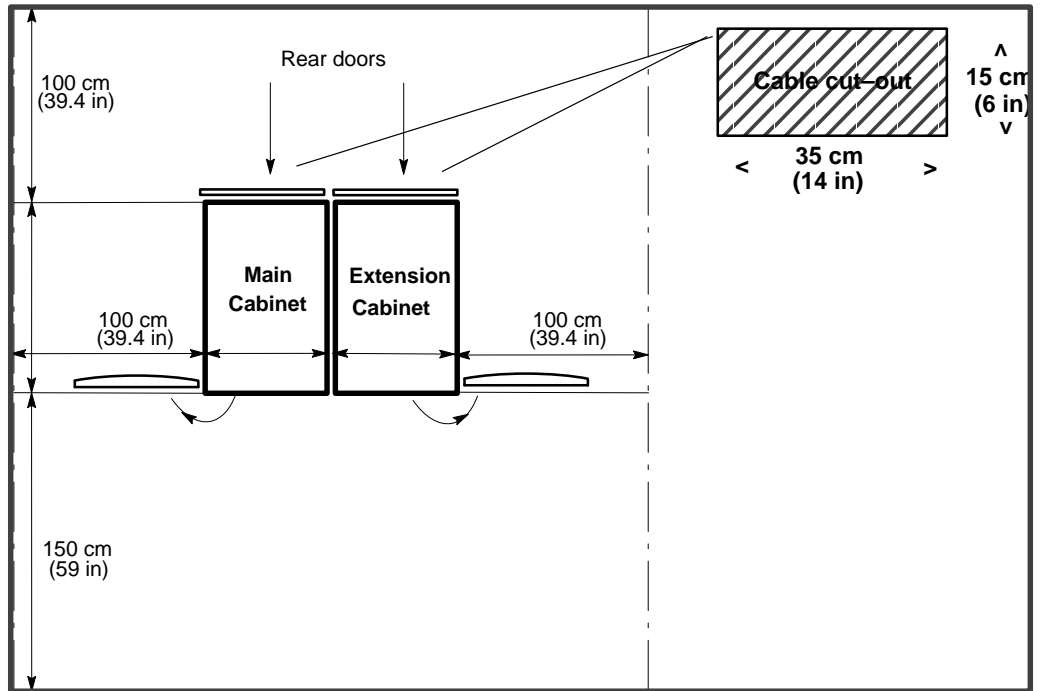

Figure 26. Dual cabinet service clearance

## Hoisting the Cabinet

### Tools Required

- Hoisting fixtures

1. Firmly secure the four hoisting fixtures to each corner of the cabinet.

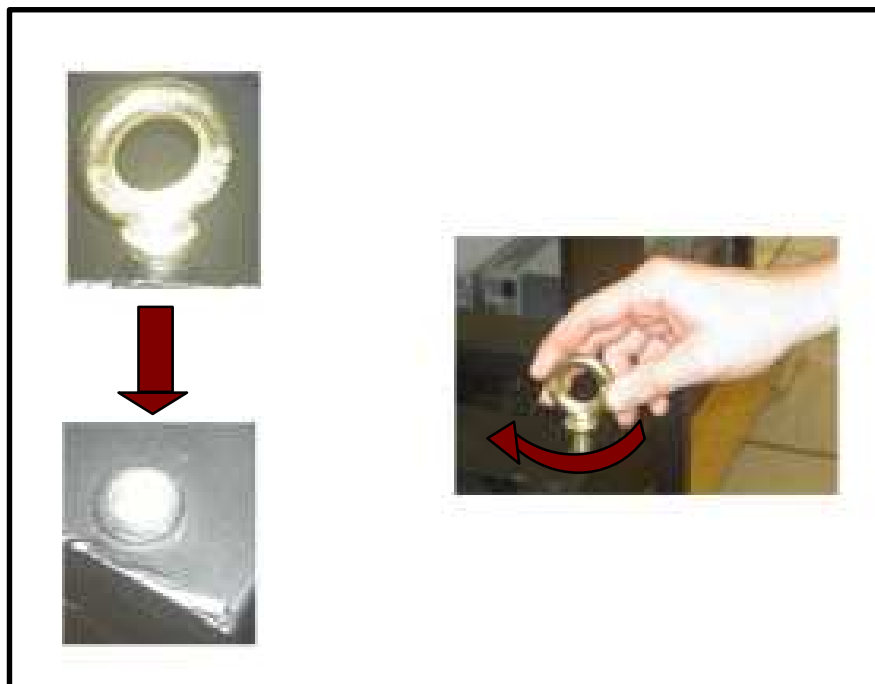

Figure 27. Installing hoisting fixtures.

2. Lift the cabinet to the required location with an appropriate hoist.

---

## Securing the Cabinet

Once the cabinet has been correctly located, it must be secured into place by lowering the jacking screws and installing the stabilizer.



### DANGER

Once equipped with servers and/or devices, the cabinet may be extremely heavy. It is mandatory for cabinet jacking screws to be locked safely into place and for the stabilizer to be installed before use or maintenance. Incorrect installation may result in serious personal injury or damage to components.

## Lowering the Jacking Screws

The jacking screws prevent the cabinet from rolling.

### Tools Required

- None

1. Manually lower and lock the two front and four rear jacking screws into place.

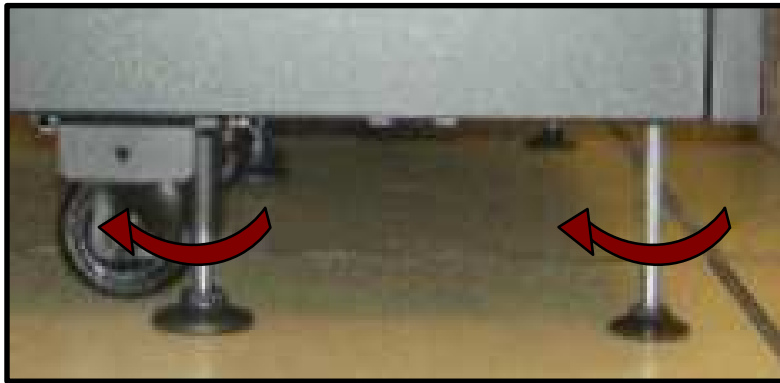

Rear view

Figure 28. Lowering jacking screws

2. Check cabinet stability.

## Installing the Stabilizer

The stabilizer prevents the cabinet from tipping, in particular during maintenance operations.

### Tools Required

- Stabilizer and fixtures
- Allen wrench
- Phillips screwdriver

1. Remove the stabilizer and fixtures from the box labeled **Open Me First**.

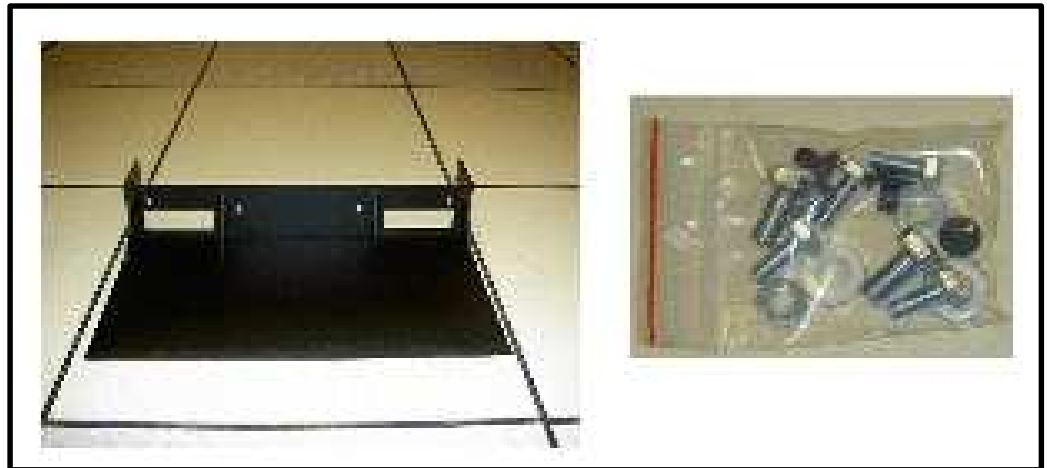

Figure 29. Stabilizer and fixtures

2. Remove the four screws securing the shipping bracket to the front of the cabinet.

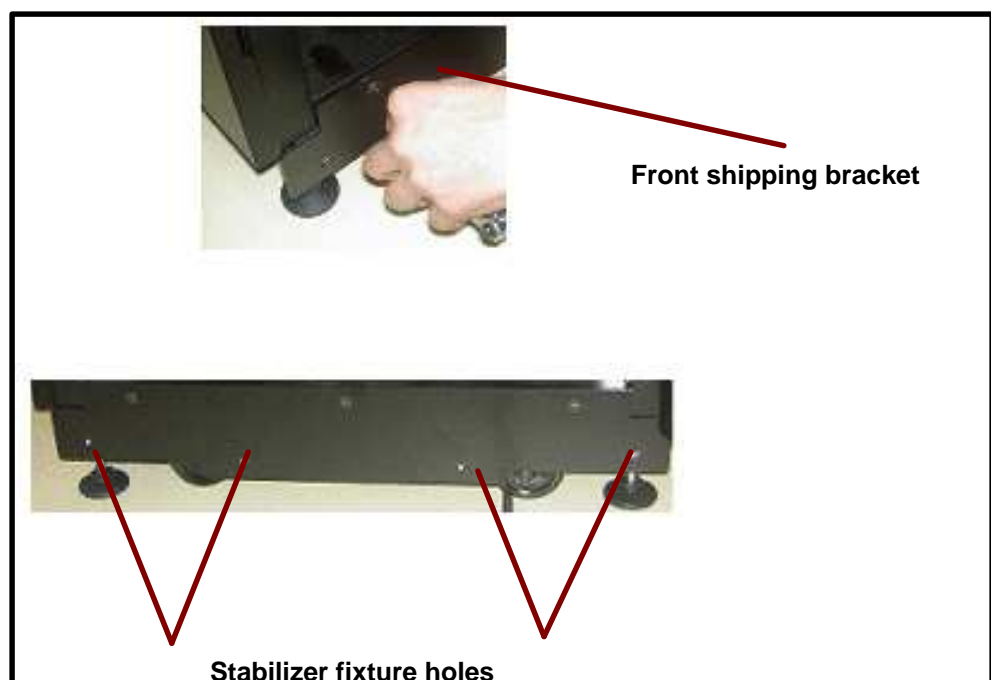

Figure 30. Removing the front shipping bracket

3. Align the six fixture holes on the stabilizer with the six holes at the base of the cabinet. Push the stabilizer into place.

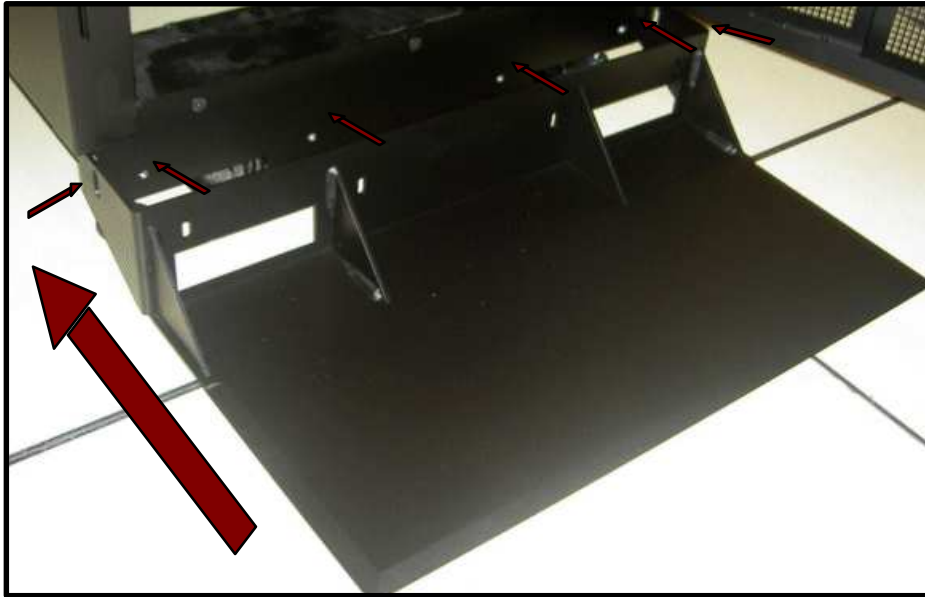

Figure 31. Aligning the stabilizer

4. Secure the stabilizer to the front of the cabinet with the screws provided. A cut-out on either side of the stabilizer allows access to the jacking screws.



Figure 32. Stabilizer cut-outs



5. Align the stabilizer trim and push into place.

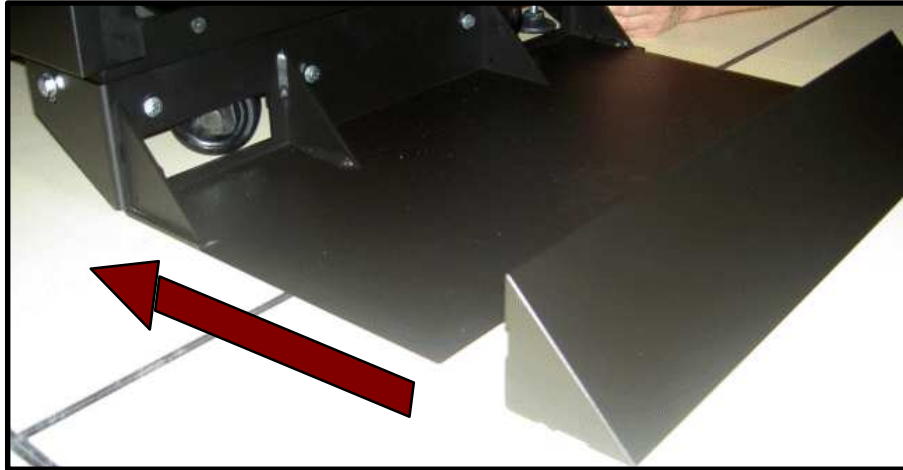

Figure 33. Installing the stabilizer trim

6. Check cabinet stability.

### Raising the Stabilizer

If you need to move the cabinet, you must first raise the stabilizer:

1. Pull the stabilizer trim forward to remove.
2. Loosen the six bolts securing the stabilizer to the cabinet base.
3. Push the stabilizer upwards.
4. Tighten the two end bolts to maintain the stabilizer in the raised position.

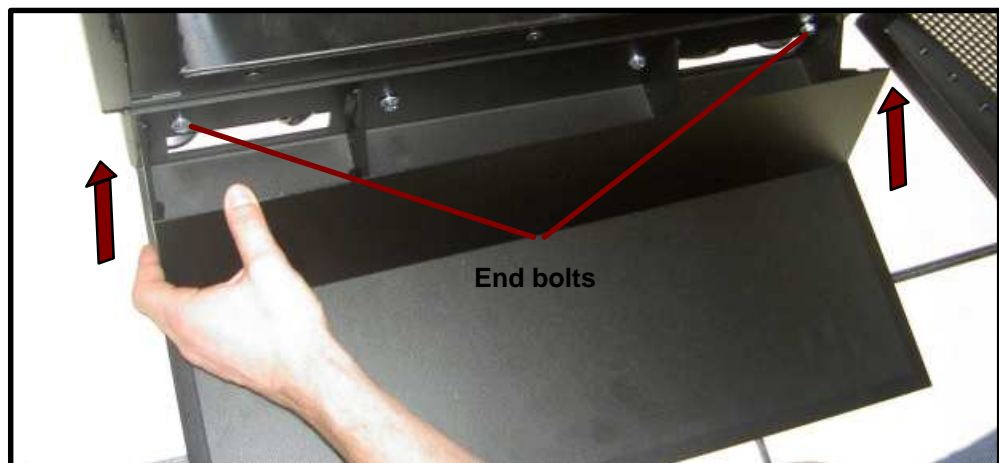

Figure 34. Raising the stabilizer

### Lowering the Stabilizer

Once the cabinet has been relocated, the stabilizer must be lowered and secured into place:

1. Loosen the two end bolts.
2. Lower the stabilizer.
3. Tighten the six bolts securing the stabilizer to the cabinet base.
4. Align the stabilizer trim and push into place.

---

## Removing / Installing Cabinet Doors and Covers

The main cabinet is delivered with the front and rear doors, left and right panels and the top cover installed.

The extension cabinet is delivered with the front and rear doors and top cover installed. Side panels may or may not be installed, according to required suite configuration.

### Removing / Installing the Front and Rear Doors

For easy access, the front and rear doors can be removed when you install or remove servers and/or devices in the cabinet.

#### Removing the Door

##### Tools Required

- Door key

1. Unlock the door and pull the handle forwards and upwards to disengage the lock.
2. Open the door. The door is secured to the hinges with two door pins.
3. Remove the bottom door pin by pulling upwards and out of the hinge.
4. Remove the top door pin by pulling upwards and out of the hinge.

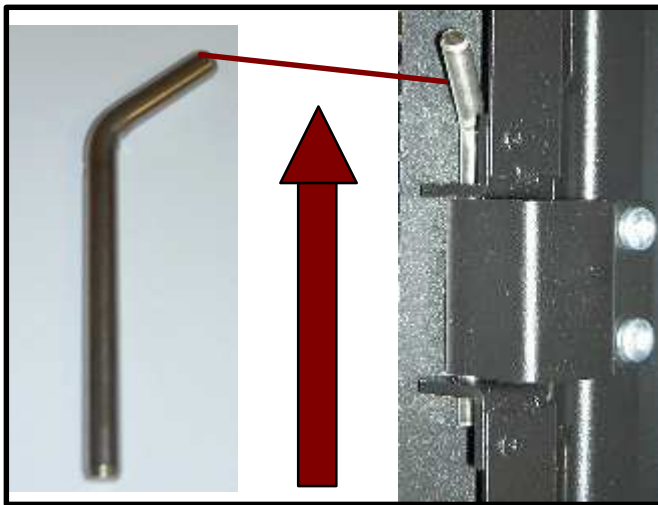

Figure 35. Removing the door

5. Firmly grip either side of the door and lift away to remove from the hinges.
6. Store the door and door pins in a safe place.

## Installing the Door

### Tools Required

- Door key

1. Firmly grip either side of the front door and place at a right angle with the cabinet.
2. Line the door up with the hinges.
3. Carefully push the door onto the hinges.
4. Insert the top door pin by pushing downwards into the hinge
5. Insert the bottom door pin by pushing downwards into the hinge.

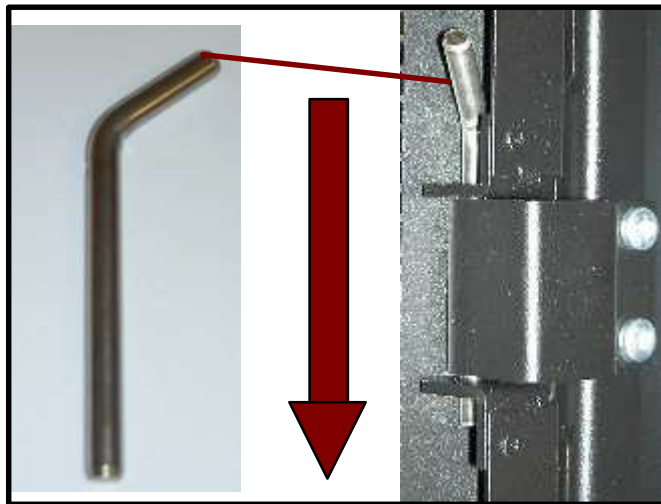

Figure 36. Installing the door

6. Close the door and engage the lock by lowering the handle and pushing it back into the recess.
7. Lock the door with the key.

## Removing / Installing Side Covers

For easy access, side covers can be removed when you install or remove servers and/or devices in the cabinet, and when you build a cabinet suite.



### Note:

Side covers cannot be removed when the front and rear door are closed.

## Removing a Side Cover

### Tools Required

- Screwdriver

1. Open the front and rear doors.
2. With the screwdriver, turn the two locks at the top of the side cover clockwise, taking care to hold the side cover in place.

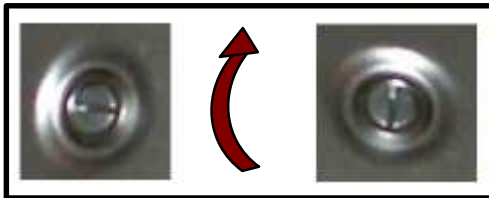

Figure 37. Opening side cover locks

3. Firmly grip either side of the side cover and lift carefully off the three lugs at the base of the cabinet.

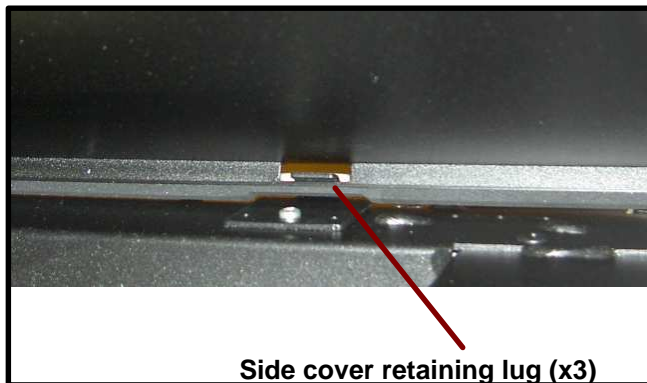

Figure 38. Side cover retaining lug

4. Store the side cover in a safe place.
5. Close the front and rear doors.

## Installing a Side Cover

### Tools Required

- Screwdriver

1. Open the front and rear doors.
2. Firmly grip either side of the side cover and lift carefully onto the three lugs at the base of the cabinet.

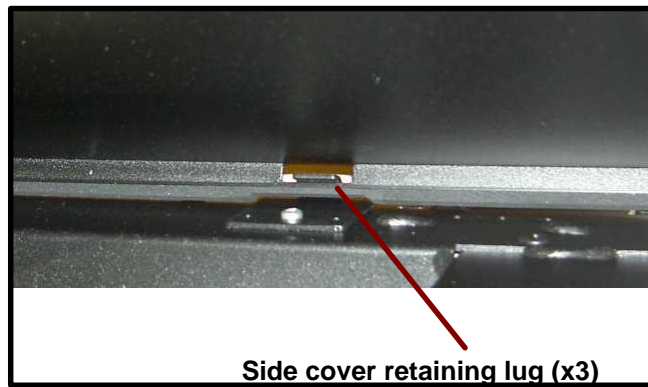

Figure 39. Side cover retaining lug

3. With the screwdriver, turn the two locks at the top of the side cover anti-clockwise, taking care to hold the side cover in place.

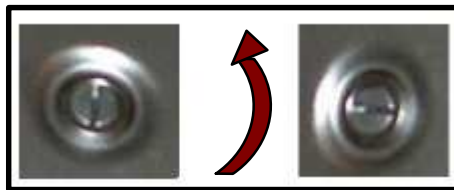

Figure 40. Closing side cover locks

4. Check that the side cover is secure.
5. Close the front and rear doors.

## Removing / Installing the 1300H/1100H Top Cover

The top cover can be removed for easy access during maintenance operations.

### Removing the Top Cover (1300H/1100H)

#### Tools Required

- Tubular socket wrench

1. Open the front and rear doors.
2. From the rear of the cabinet, loosen the two nuts securing the top cover to the cabinet.



Figure 41. Unscrewing the top cover

3. Push the cover upwards and pull away from the front of the cabinet.



Figure 42. Removing the top cover

4. Store the top cover and fixtures in a safe place.
5. Close the front and rear doors.

## Installing the Top Cover (1300H/1100H)

### Tools Required

- Tubular socket wrench

1. Open the front and rear doors.
2. From the rear of the cabinet, push the top cover into the two retaining lugs at the front of the cabinet and push downwards into place.



Figure 43. Installing the top cover (1300H/1100H)

3. Tighten the two nuts securing the top cover to the cabinet.



Figure 44. Securing the top cover (1300H/1100H)

4. Check that the top cover is secure.
5. Close the front and rear doors.

## Removing / Installing the 1300L/1100L Top Cover

The top cover can be removed for easy access during maintenance operations.

### Tools Required

- Phillips screwdriver

### Removing the 1300L/1100L Top Cover

1. Open the front and rear doors.
2. Remove both side covers. See **Removing / Installing Side Covers, on page 2-22**.
3. From each side of the cabinet, unscrew the two screws securing the top cover to the cabinet frame.

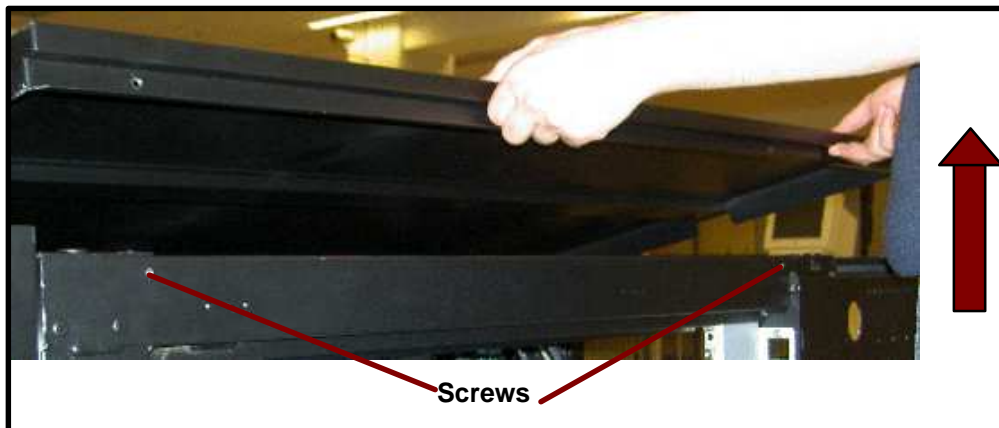

Figure 45. Removing the top cover (1300L/1100L)

4. Lift the top cover free of the cabinet frame.
5. Store the top cover and fixtures in a safe place.
6. Refit the side covers. See **Removing / Installing Side Covers, on page 2-22**.
7. Close the front and rear doors.



## Installing the 1300L/1100L Top Cover

1. Open the front and rear doors.
2. Remove both side covers. See **Removing / Installing Side Covers, on page 2-22**.
3. Carefully lower the top cover onto the cabinet frame, taking care to align screw holes on each side of the cover and frame.

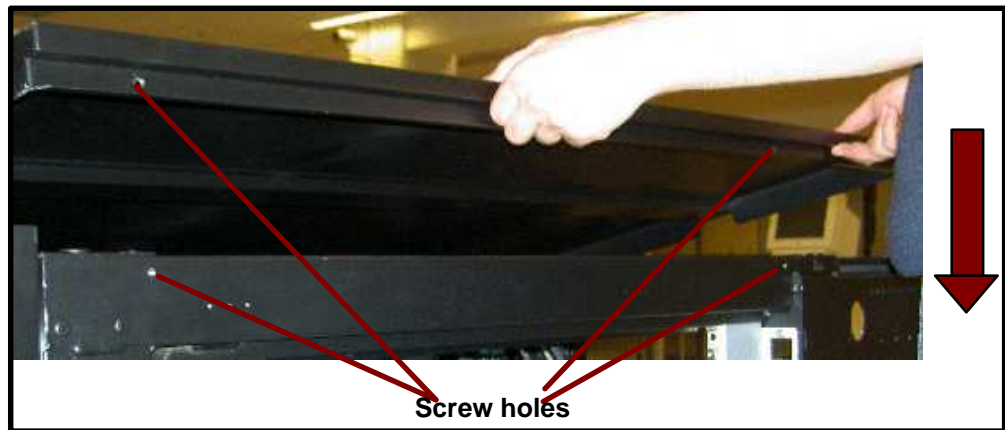

Figure 46. Installing the top cover (1300L/1100L)

4. From each side of the cabinet, tighten the two screws securing the top cover to the cabinet frame.
5. Check that the top cover is secure.
6. Refit the side covers. See **Removing / Installing Side Covers, on page 2-22**.
7. Close the front and rear doors.

## Turning the Front and/or Rear Door

You can turn the front and/or rear door to change the opening direction to suit site configuration requirements.

### Tools Required

- Screwdriver

1. Remove the door. See **Removing / Installing the Front and Rear Doors, on page 2-20**.
2. Turn the door up the other way.
3. Unscrew the locking bracket on the cabinet flange and screw back onto the opposite cabinet flange.



### Note:

#### Rear door only:

Use the locking bracket provided in the box labeled *Open Me First*.

4. Unscrew the lock on the door, turn up the other way, and screw back into place.
5. Unscrew the locking mechanism, turn up the other way, and screw back into place on the other side of the lock.
6. Unscrew the logo, turn up the other way and screw back into place.
7. Refit the door. See **Removing / Installing the Front and Rear Doors, on page 2-20**.

## Adding an Extension Cabinet

Each extension cabinet is delivered with the spacers and fixtures required to build a suite.

### Preparing the Cabinets

1. Remove the required side cover from the cabinet in place (left or right, according to suite configuration). See *Removing / Installing Side Covers*, on page 2-22.
2. If required, remove the installed side cover from the extension cabinet (left or right, according to suite configuration). See *Removing / Installing Side Covers*, on page 2-22.
3. Move the extension cabinet to the required location. See *Moving the Cabinet*, on page 2-14.
4. Align the extension cabinet with the cabinet in place and adjust.
5. Secure the extension cabinet into place. See *Securing the Cabinet*, on page 2-16.

### Fitting Front Spacers



**Note:**

The short end of the spacer is fitted at the top or bottom edge of the cabinet.

#### Tools Required

- Phillips screwdriver
- 2 spacers and fixtures

1. Align the spacer with the door hinge at the top of the cabinet and push into place.

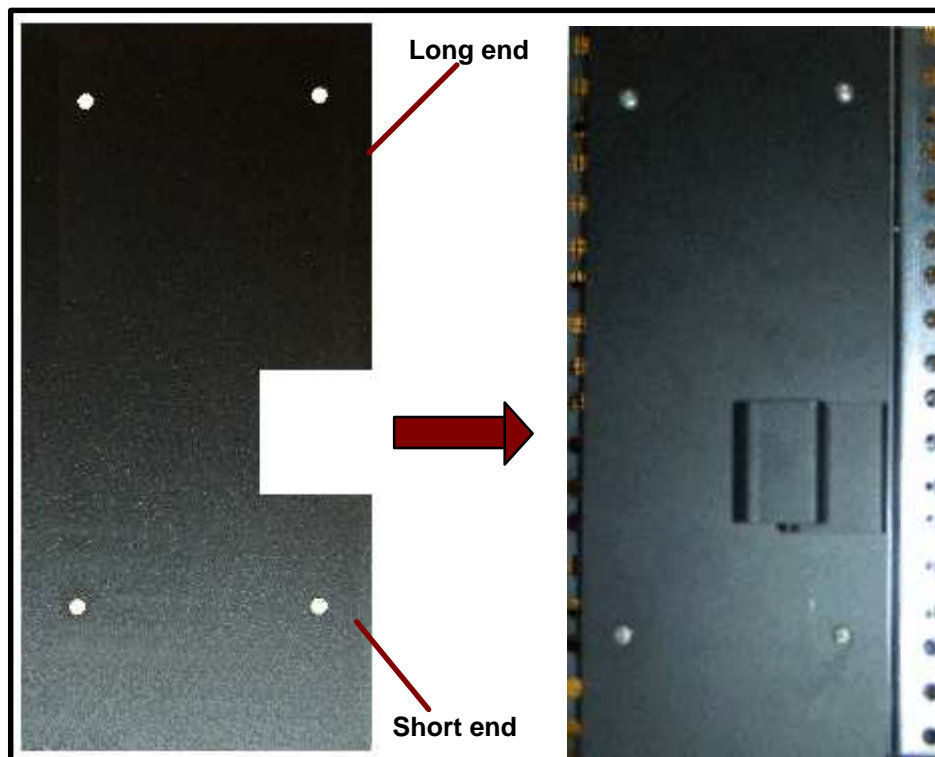

Figure 47. Fitting a front spacer

2. Tighten the 4 screws securing the spacer to the cabinet frame.
3. Repeat Steps 1 and 2 to fit the bottom spacer.

## Fitting Rear Spacers



### Note:

The short end of the spacer is fitted at the top or bottom edge of the cabinet.

### Tools Required

- Phillips screwdriver
- 2 spacers and fixtures

1. Align the spacer with the door hinge at the top of the cabinet.

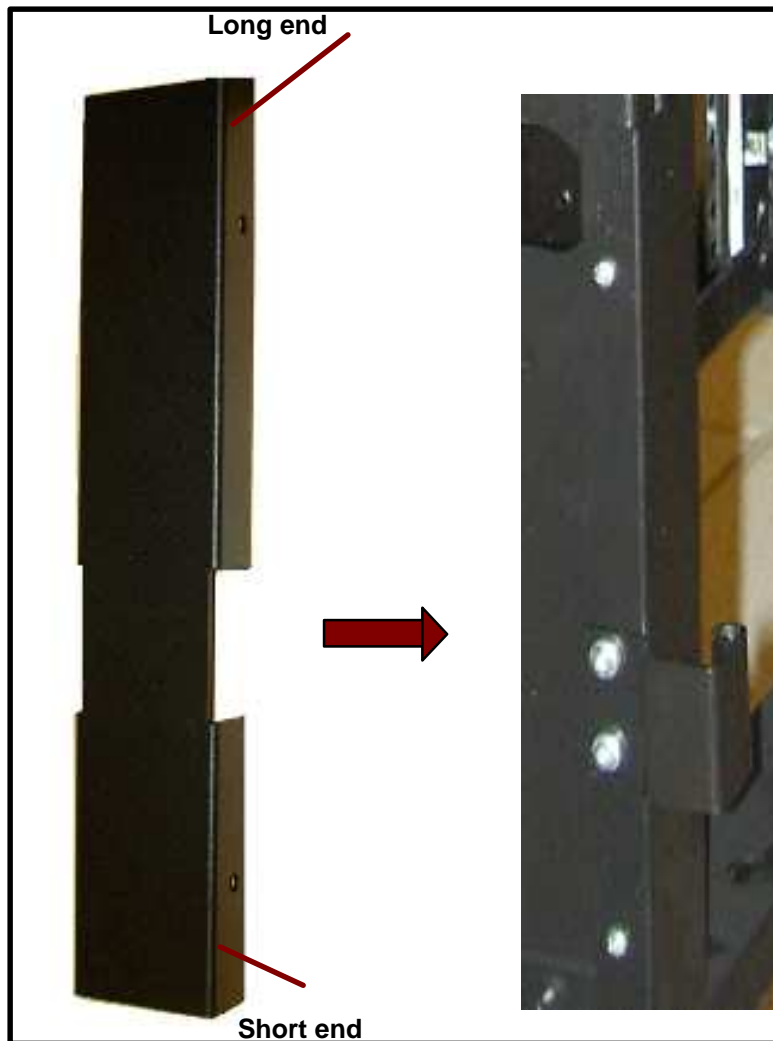

Figure 48. Fitting a rear spacer

2. Tighten the 4 screws securing the spacer to the cabinet frame.
3. Repeat Steps 1 and 2 to fit the bottom spacer.

## Fitting the Top Spacer



### Note:

The short end of the spacer is fitted at the front of the cabinet.

### Tools Required

- Phillips screwdriver
- 1 spacer and fixtures

1. Align the 8 top spacer screw holes with the 4 screw holes on the top of each cabinet frame.

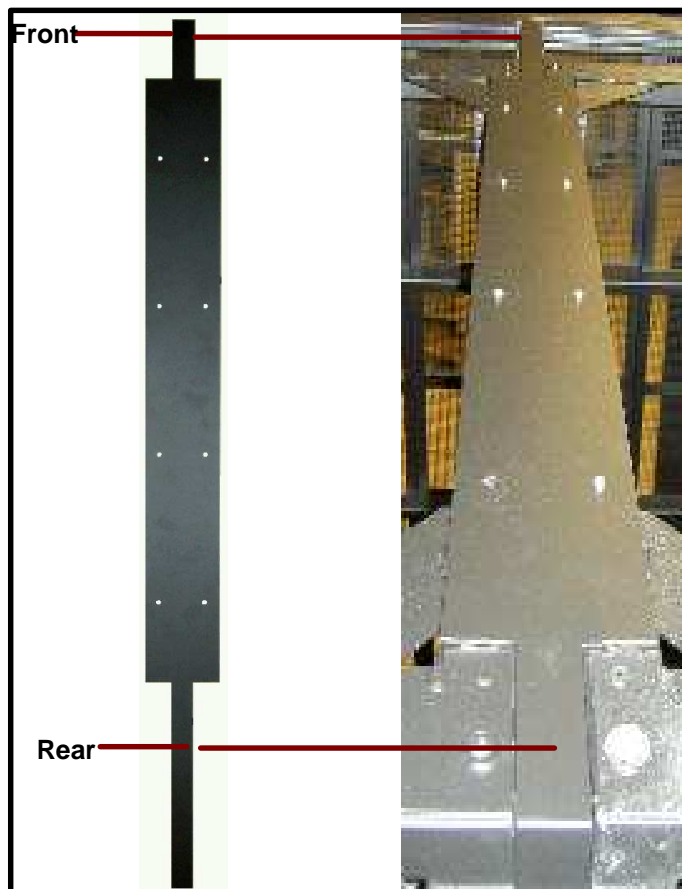

Figure 49. Fitting the top spacer

2. Insert and tighten the 8 screws securing the spacer to the cabinet frames.

## Replacing Side Covers

1. Install the side cover previously removed from the cabinet in place on the extension cabinet (left or right, according to suite configuration). See *Removing / Installing Side Covers*, on page 2-22.
2. Repeat these procedures for each extension cabinet you want to add to the suite.

---

## Installing Servers and/or Devices



**Important:**

You are requested to read the Safety Notices set out in Appendix C. before installing or servicing cabinets.

The documentation delivered with rack-mountable servers and devices may contain important safety information. You are requested to carefully read the documentation delivered with servers and devices before installing them in the cabinet.



**DANGER**

- Jacking screws must always be lowered.
- Stabilizers must always be installed.
- Servers and devices must always be fitted in the cabinet from the bottom upwards.
- Servers and devices must be fitted in the cabinet so that the air-flow is from front to back: all fans blowing towards the rear of the cabinet.
- The weight of servers and devices fitted in the cabinet must not exceed 20 kg (44 lbs) per U.
- Never slide more than one server or device out of the rack at a time.
- Thermal dissipation must not exceed 400 W per U mean, 700 W per U peak.
- Firmly secure servers and devices to the mounting flanges at the front and rear of the cabinet.
- Always use the mounting fixtures supplied with the servers and/or devices.



**Note:**

A specific integration kit may be required to install short servers or devices in a 1300H / 1300L cabinet. Refer to *Fitting a Short Integration Kit*, on page 2-34.

## Checking Server / Device Compatibility

Before installing a server or device in the cabinet, you are advised to check and compare the internal dimensions of the cabinet with the external dimensions of the server / device and accessories (rail assembly, front bezel, handles, ...).

The following figure shows a top view of the cabinet and illustrates the dimensions to be taken into account before installing a server or device in the cabinet.

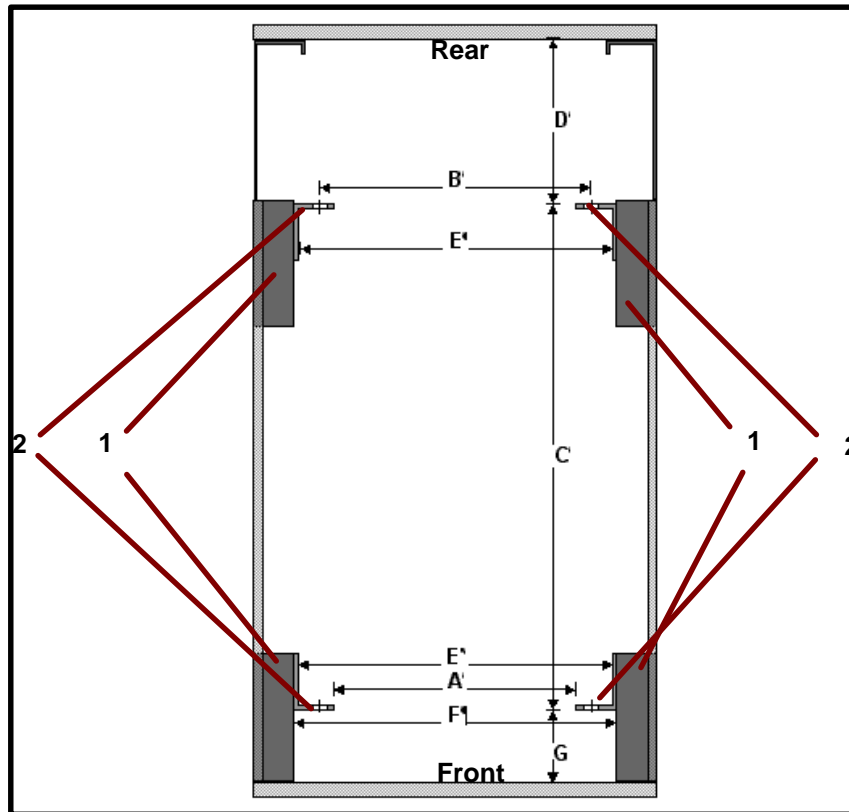

	1100	1300	
<b>1</b>	N/A	N/A	Mounting columns
<b>2</b>	N/A	N/A	Mounting flanges
<b>A</b>	450	450	Distance between the outer ends of the two front mounting flanges. Clearance required to insert the server/device.
<b>B</b>	465	465	Distance between the centers of the front and rear mounting flange holes.
<b>C</b>	736	920	Distance between the front and rear mounting flanges. Clearance comprised between the minimum and the maximum sizes of the server/device adjustable rail assembly.
<b>D</b>	210	210	Distance between the rear mounting flange and the inside rear door. Clearance available for cabling.
<b>E</b>	487	487	Distance between the inner sides of the front mounting flanges. Clearance must be greater than the width of the server/device including rail assemblies and must be available from front to rear mounting flanges.
<b>E'</b>	591	591	Distance between the inner sides of the rear mounting flanges. FRONT CLERANCE (E) TO BE TAKEN INTO CCOUNT ONLY.
<b>F</b>	495	495	Distance between the front mounting columns. Dimension required to secure front bezels and server/device handles.
<b>G</b>	55	55	Distance between the front mounting flanges and the inside front door. Dimension required to secure front bezels and server/device handles.

Figure 50. Internal cabinet dimensions

## Fitting a Short Integration Kit

An integration kit may be required to rack-mount short servers or devices in 1300H/1300L cabinets. Integration kits are available in two sizes: 1U and 2U.



### Important:

The documentation delivered with rack-mountable servers and devices may contain important safety information. You are requested to carefully read the documentation delivered with servers and devices before installing them in the cabinet.



### Note:

1 U = 44.45 mm (1.75 in)

### Tools Required

- Hex wrench
- Integration brackets and fixtures

1. Select the required location on the two front or rear cabinet mounting flanges.
2. Mark off a 1U or a 2U high section on the selected left and right mounting flanges.

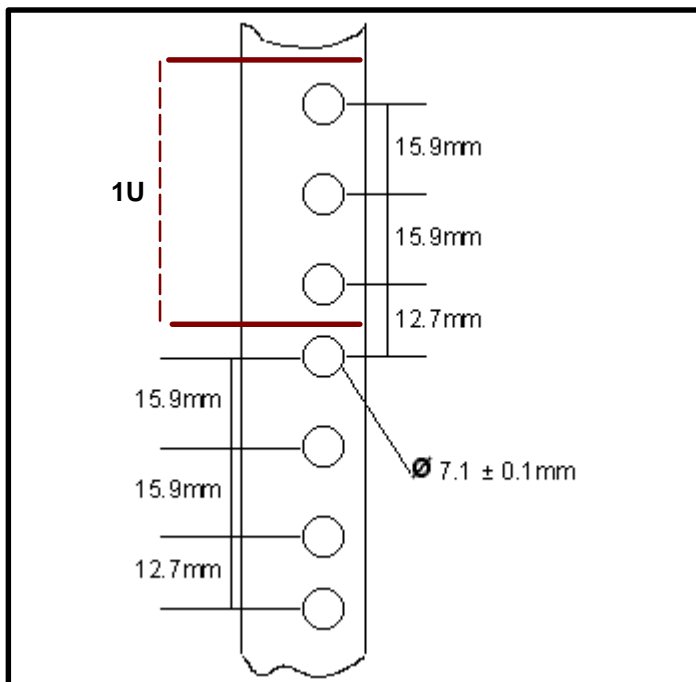

Figure 51. Mounting flange hole size and placement



3. Align the left integration bracket fixture holes with the mounting flange fixture holes and bolt firmly into place.

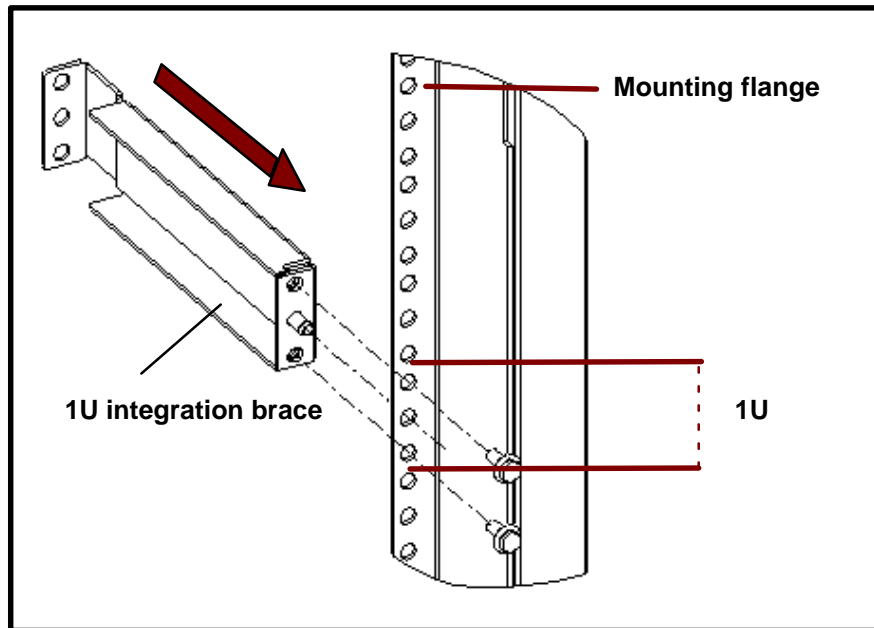

Figure 52. Fitting a 1U integration bracket

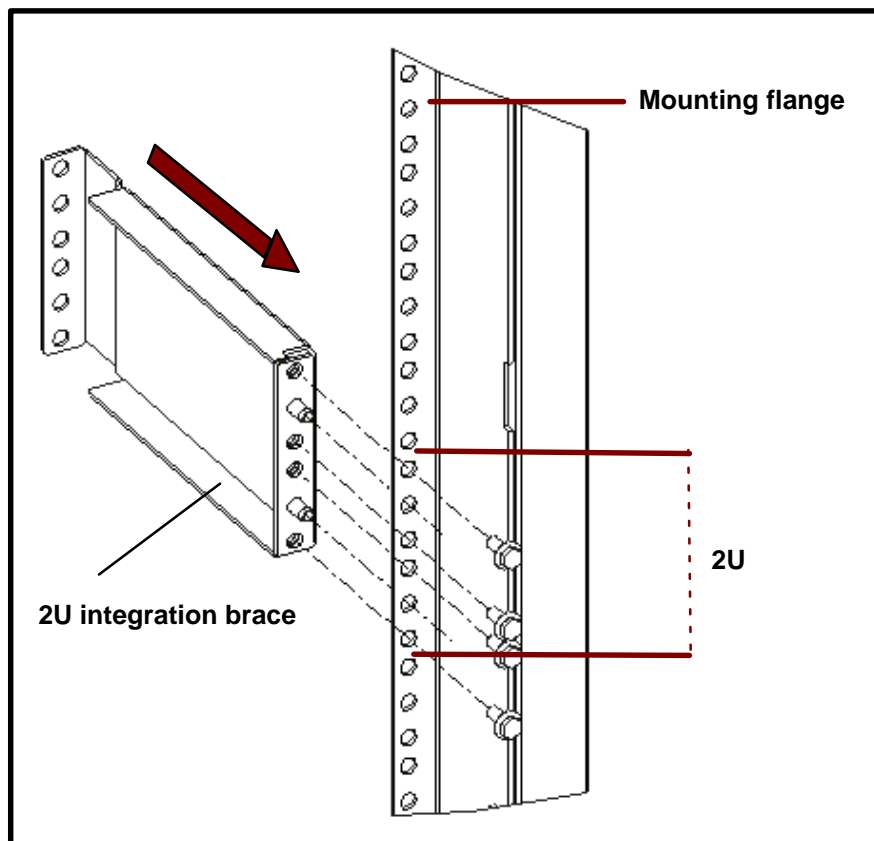

Figure 53. Fitting a 2U integration bracket

4. Repeat Step 3 for the right integration bracket.

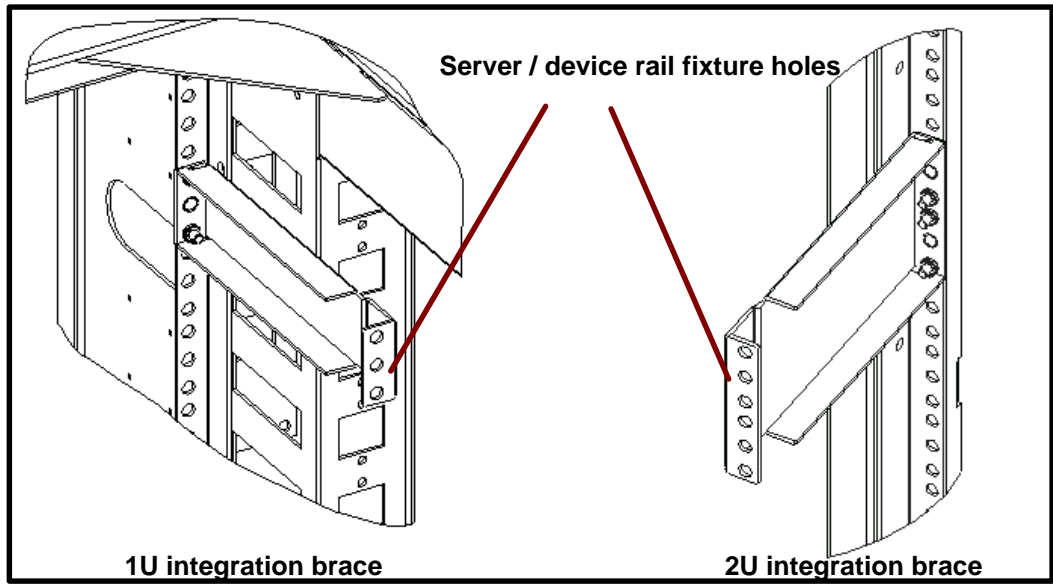

Figure 54. 2U and 1U integration brackets

5. Secure the server or device runners to the left and right integration brackets, as explained in the documentation delivered with the server / device.

## Fitting Equipment Trays

An equipment tray may be required to fit peripheral devices in cabinets.

Three equipment trays are available:

- Short Equipment Tray
- Medium Equipment Tray
- Long Equipment Tray



### Important:

The documentation delivered with non-rackable peripheral devices may contain important safety information. You are requested to carefully read the documentation delivered with these devices before installing them on the equipment tray.

### Mounting Flange Hole Size and Placement



#### Note:

1 U = 44.45 mm (1.75 in)

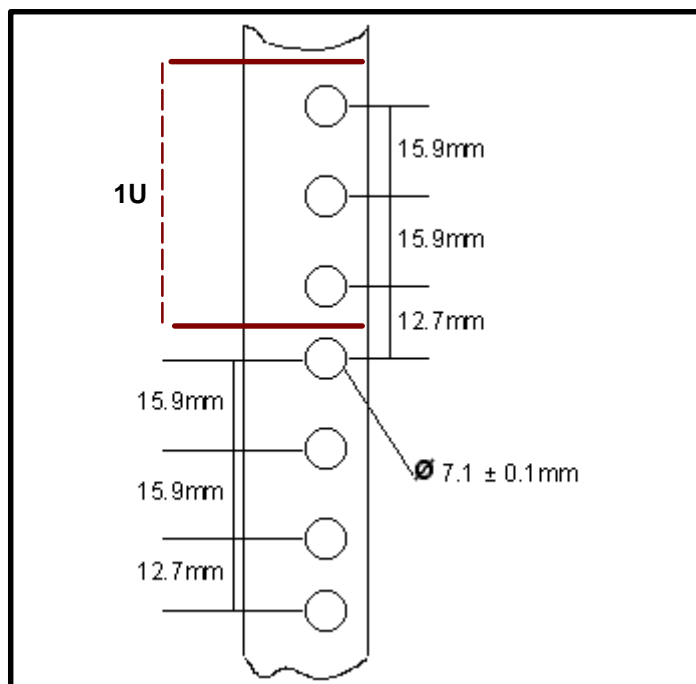

Figure 55. Mounting flange hole size and placement

## Fitting a Short Equipment Tray

The short equipment tray is used to house non-rackable devices in the cabinet. It offers the following features:

- Length: 441 mm
- Depth: 220 mm
- Height: 42 mm (1U)
- Maximum safe load: 3 kg

### Tools Required

- Torx screwdriver
- Short equipment tray and fixtures

1. Select the required location on the two front or rear cabinet mounting flanges.
2. Mark off a 1U high section on the selected left and right mounting flanges. See Figure 55. Mounting flange hole size and placement, on page 2-37.
3. Install 2 cage nuts over the required rack fixture holes on each side of the cabinet.
4. Insert the tray in the cabinet, behind the mounting flanges.

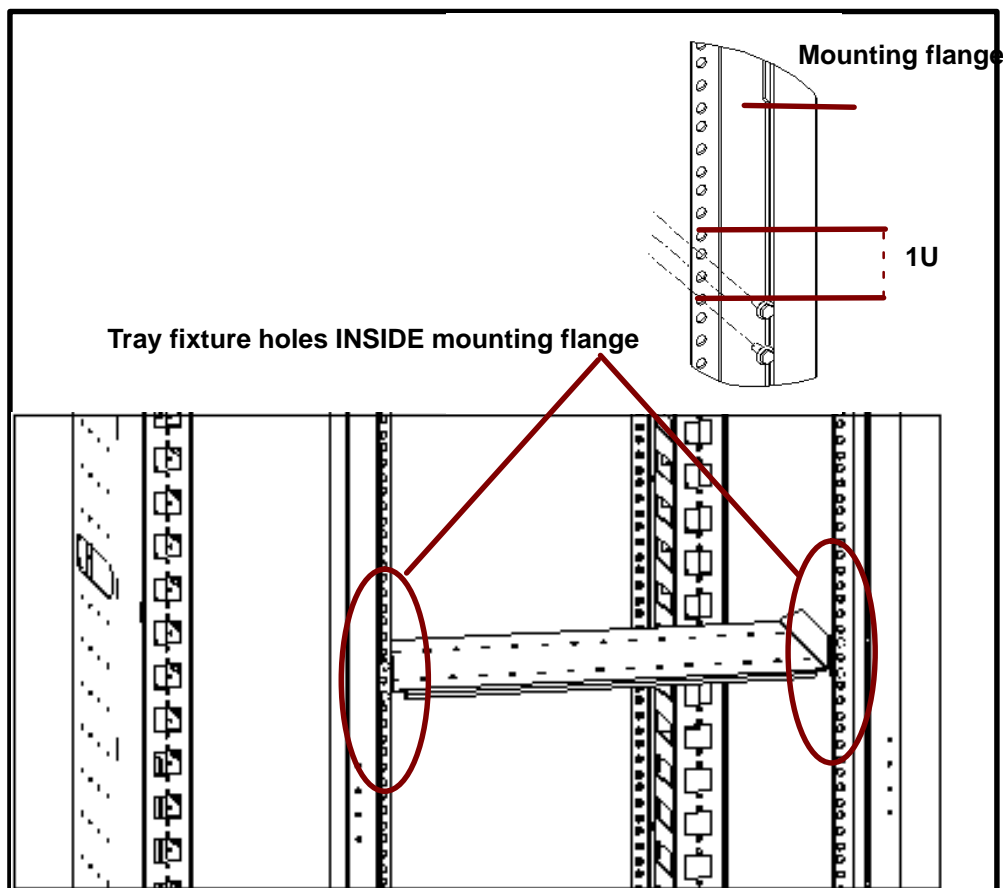

Figure 56. Fitting a short equipment tray

5. Align the left tray fixture holes against the internal mounting flange fixture holes and bolt firmly into place.
6. Repeat Step 5 for the right tray fixture holes.
7. Secure the device(s) to the tray, as explained in the appropriate documentation.

## Fitting a Medium Equipment Tray

The medium equipment tray is used to house non-rackable devices in the cabinet. It offers the following features:

- Length: 441 mm
- Depth: 358.5 mm
- Height: 88 mm (2U)
- Maximum safe load: 15 kg

### Tools Required

- Torx screwdriver
- Medium equipment tray and fixtures

1. Select the required location on the two front or rear cabinet mounting flanges.
2. Mark off a 2U high section on the selected left and right mounting flanges. See Figure 55. Mounting flange hole size and placement, on page 2-37.
3. Install 2 cage nuts over the required rack fixture holes on each side of the cabinet.

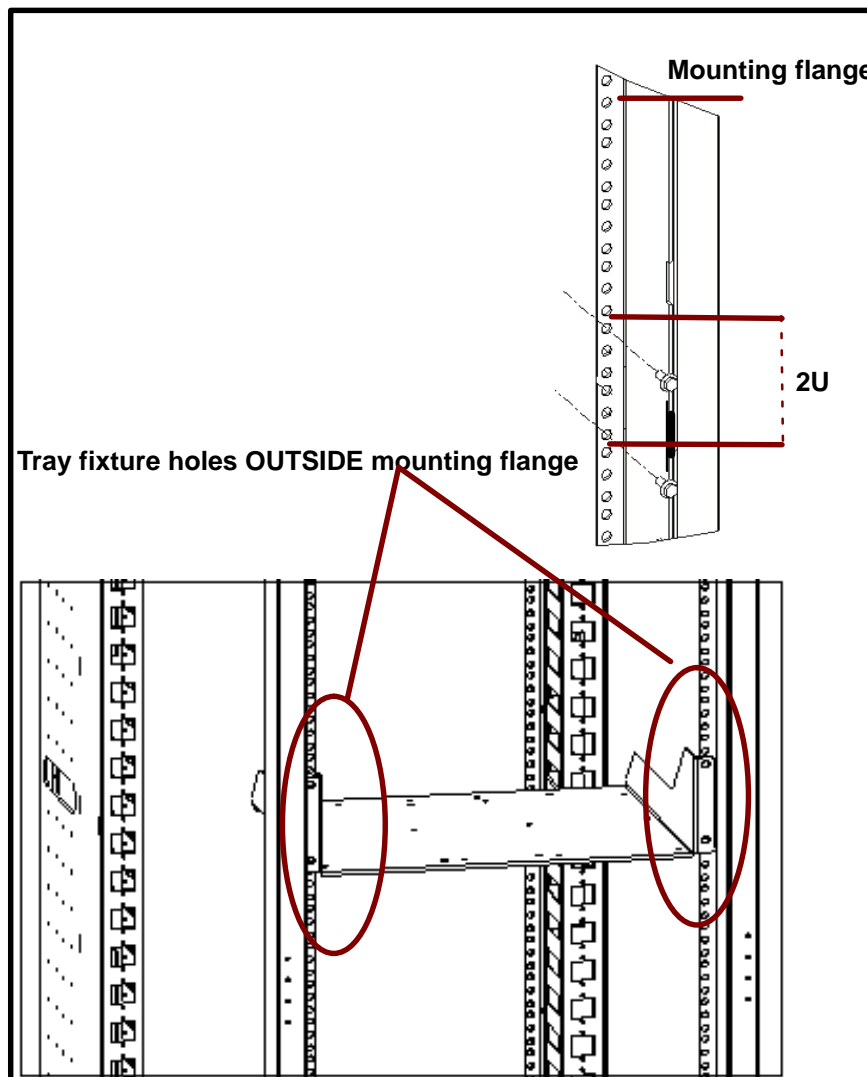

Figure 57. Fitting a medium equipment tray

4. Insert the tray in the cabinet.

5. Align the left tray fixture holes against the external mounting flange fixture holes and bolt firmly into place.
6. Repeat Step 5 for the right tray fixture holes.
7. Secure the device(s) to the tray, as explained in the appropriate documentation.

## Fitting a Long Equipment Tray

The multi-purpose, long equipment tray is used to house both non-rackable and rackable devices in the cabinet. It offers the following features:

- Length: 440 mm
- Depth: 788 mm
- Height: 44 mm (1U)
- Maximum safe load: 10 kg (for non-rackable devices)  
50 kg (for rackable devices)

### Tools Required

- Torx screwdriver
- Hex wrench
- Long equipment tray and fixtures
- Leveling pads (for rackable devices)

## Mounting the Long Equipment Tray Integration Bracket

1. Insert the left integration bracket fixture pins in the left tray fixture holes.
2. Loosely tighten the washer nuts to maintain in place.

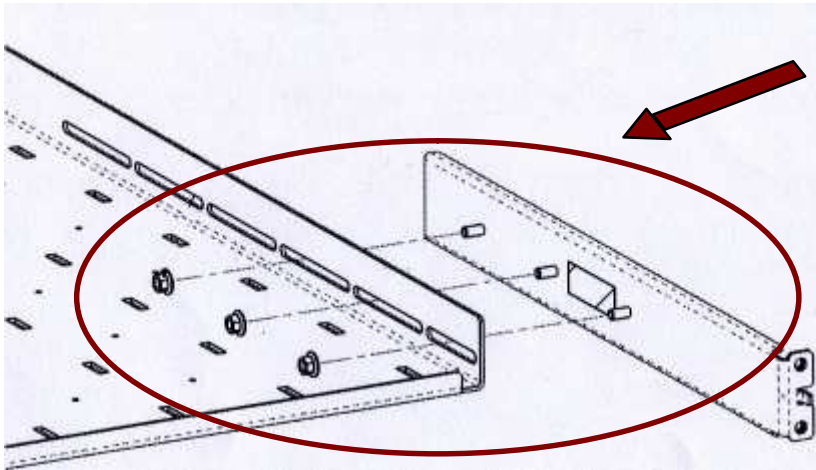

Figure 58. Mounting the long equipment tray integration bracket

3. Repeat Steps 1 and 2 for the right integration bracket.

## Fitting the Long Equipment Tray for Non-Rackable Devices

1. Select the required location on the two front and rear cabinet mounting flanges.
2. Mark off a 1U high section on the selected front and rear, left and right mounting flanges. See Figure 55. Mounting flange hole size and placement, on page 2-37.
3. Turn the tray so that the base is at the bottom.
4. Insert the tray in the cabinet, behind the mounting flanges.

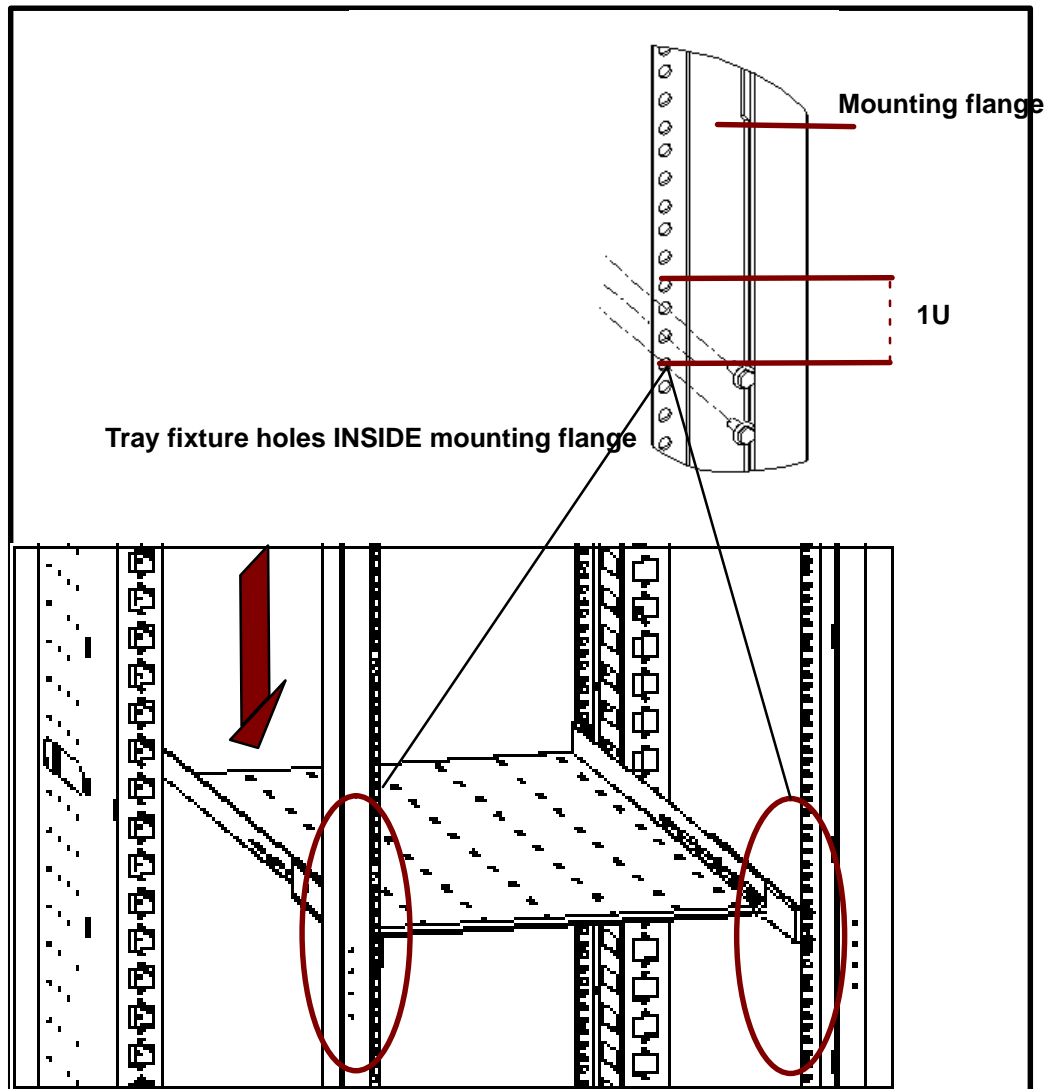

Figure 59. Fitting the long equipment tray for non-rackable devices

5. Align the left integration bracket fixture holes with the front internal mounting flange fixture holes and bolt firmly into place.
6. Repeat Step 5 for the right integration bracket.
7. Align the left tray fixture holes with the rear internal mounting flange fixture holes and bolt firmly into place.
8. Repeat Step 7 for the right tray fixture holes.
9. Firmly tighten the washer and nut assemblies securing the tray to the left and right integration brackets.
10. Secure the device(s) to the tray, as explained in the appropriate documentation.

## Fitting the Long Equipment Tray for Rackable Devices

1. Select the required location on the two front and rear cabinet mounting flanges.
2. Mark off a 1U high section on the selected front and rear, left and right mounting flanges. See Figure 55. Mounting flange hole size and placement, on page 2-37.
3. Turn the tray so that the base is at the top.
4. Insert the tray in the cabinet, behind the mounting flanges.

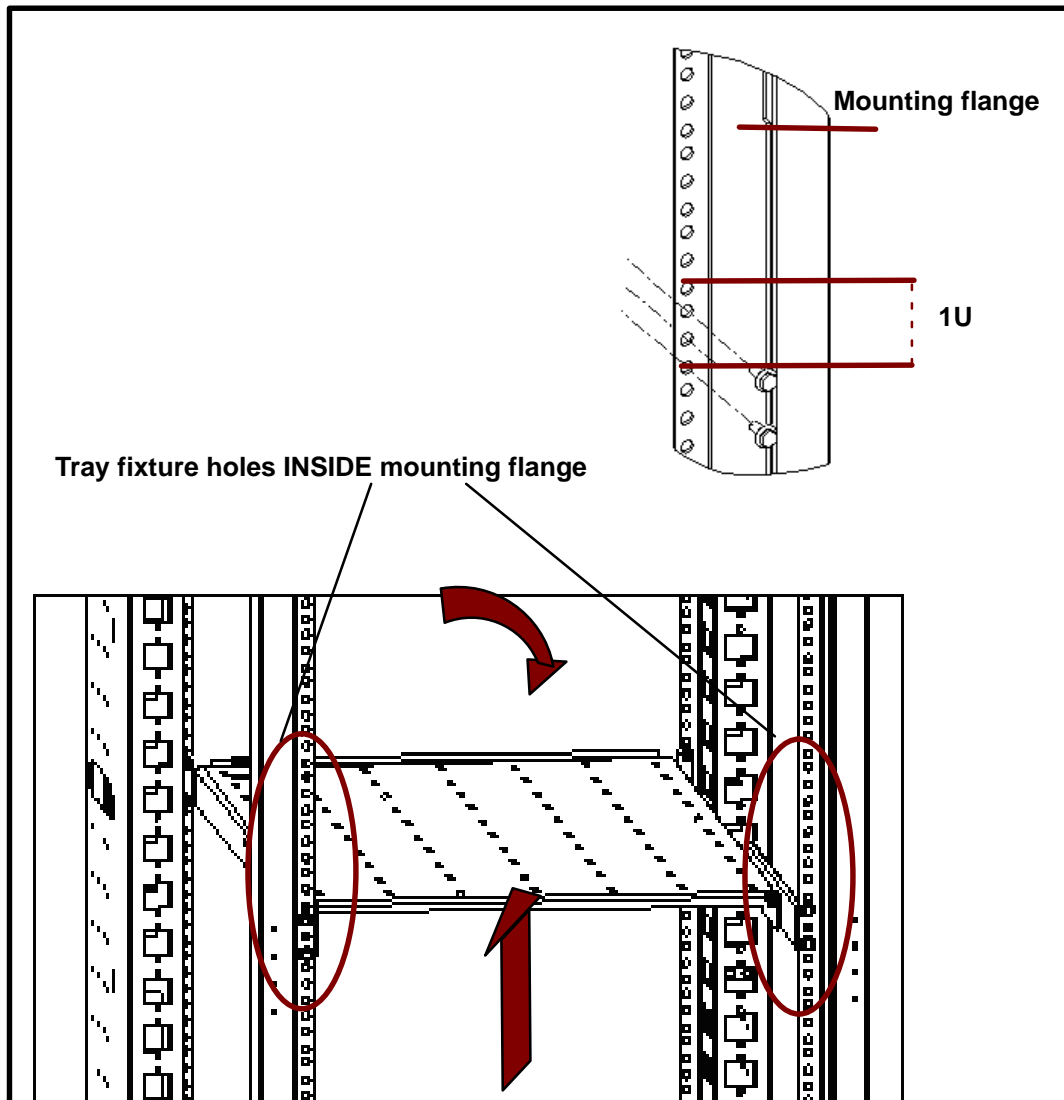

Figure 60. Fitting the long equipment tray for rackable devices

5. Align the left integration bracket fixture holes with the front internal mounting flange fixture holes and bolt firmly into place.
6. Repeat Step 5 for the right integration bracket.
7. Align the left tray fixture holes with the rear internal mounting flange fixture holes and bolt firmly into place.
8. Repeat Step 7 for the right tray fixture holes.
9. Firmly tighten the washer and nut assemblies securing the tray to the left and right integration brackets.



10. Align the left leveling pad fixture pins with the tray base fixture holes and bolt into place.
11. Repeat Step 10 for the right leveling pad.

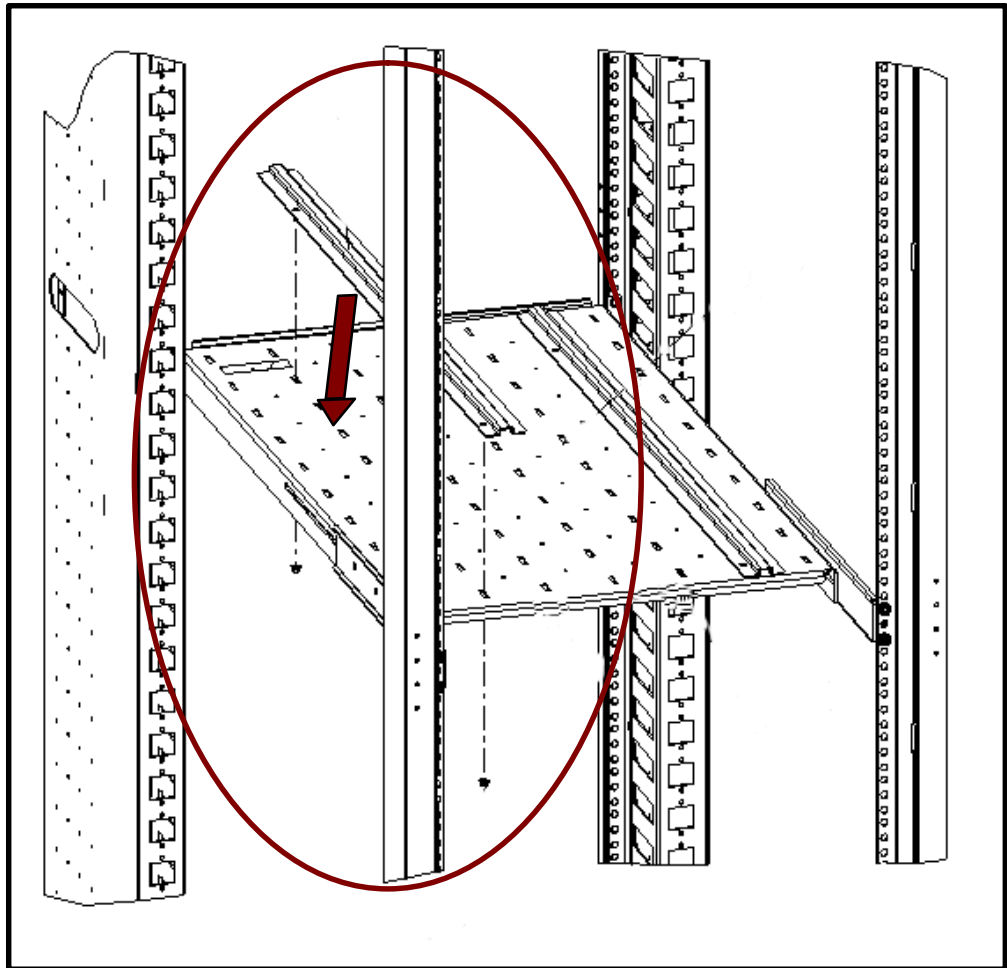

Figure 61. Installing long equipment tray leveling pads

12. Mount the device in the racks, as explained in the appropriate documentation.

## Installing a PDU

Each PDU is delivered with mounting brackets for vertical and/or horizontal installation in the cabinet.



### Note:

#### Vertical Installation

Up to two PDUs can be installed vertically in the 1300L and 1100L cabinets and up to four PDUs can be installed vertically in the 1300H and 1100H cabinets.



### Important:

Before choosing a location for a PDU, check power cable length from the servers and devices you want to connect to the PDU.

Before proceeding to install the PDU, check that the circuit breaker switch is OFF.

#### Tools Required

- Hex wrench
- PDU fixtures

#### Vertical Installation

1. Select the required location in the cabinet.
2. Install one cage nut (A) over the fixture holes at the top and bottom of the cabinet cut-out.

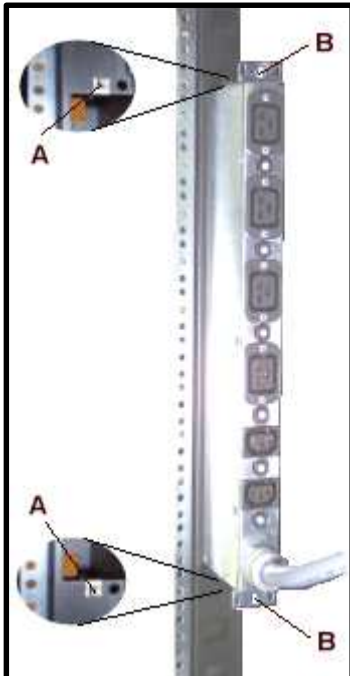

Figure 62. Installing a PDU vertically

3. Align the PDU with the cut-out in the cabinet flange and push firmly into place.
4. Insert the bolt and washer assemblies in the central PDU fixture holes (B) and tighten with the hex wrench.

### Horizontal Installation

1. Select the required location in the cabinet.
2. Install 2 cage nuts (A) over the required rack fixture holes on each side of the cabinet.

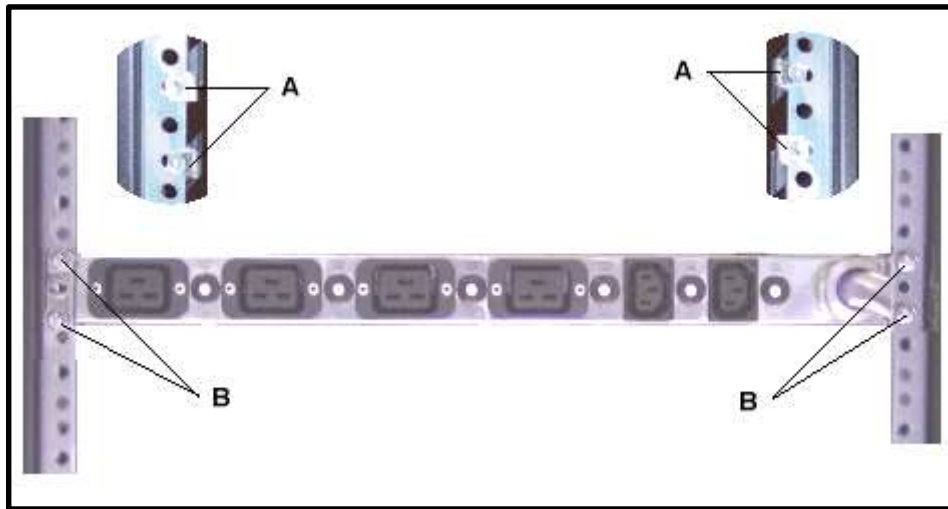

Figure 63. Installing a PDU horizontally

3. Align the PDU fixture holes with the rack fixture holes on the left and right sides of the cabinet.
4. Insert the bolt and washer assemblies in the top and bottom PDU fixture holes (B) and tighten with the hex wrench.



---

## Chapter 3. Managing Power and Data Cables

This chapter gives general recommendations for routing and connecting power and data cables inside the cabinet. It includes the following topics:

- Routing Data Cables, on page 3-2
- Routing and Connecting Power Cables, on page 3-3
- Connecting the PDU to the Site Power Supply, on page 3-3



**Important:**

**Please refer to the documentation delivered with your server and/or device for detailed cable management information.**

---

## Routing Data Cables

Please refer to the documentation delivered with your server and/or device for detailed cable management information.



**Important:**

### **GENERAL RECOMMENDATIONS**

1. Label all cables for easy identification.
2. Secure cables with appropriate fixtures.
3. Ensure that cables are clear of doors and panels.
4. Do not bend cables (in particular fiber-optic cables) beyond limited specifications.
5. Take care not to route cables in front of other servers or devices.
6. When servers or devices are installed on slide rails:
  - Leave extra cable lengths for full mobility.
  - Route cables along cable arms and secure with appropriate fixtures.

## Routing Inter-Cabinet Data Cables



**DANGER**

**Power cables must NEVER be routed between cabinets.**



**Important:**

**Route inter-cabinet data cables through the cable openings at the rear of the cabinets.**

---

## Routing and Connecting Power Cables

Please refer to the documentation delivered with your server and/or device for detailed cable management information.



### Important:

#### GENERAL RECOMMENDATIONS

1. Label all cables for easy identification.
2. Secure cables with appropriate fixtures.
3. Ensure that cables are clear of doors and panels.
4. Take care not to route cables in front of other servers or devices.
5. When servers or devices are installed on slide rails:
  - Leave extra cable lengths for full mobility.
  - Route cables along cable arms and secure with appropriate fixtures.
6. Check that the PDU is compliant with server and/or device power requirements.

## Connecting a PDU to the Site Power Supply

As required in the *Site Preparation Guide*, the Customer has provided the required power supply cables to the cable cut-outs at the base of the cabinet.

The Customer is responsible for ensuring that the electrical network is compliant with the standards set out in the *Site Preparation Guide*.

PDU power cables are equipped with ready-mounted IEC60309 plugs. The Customer is responsible for supplying the appropriate IEC60309 sockets for connection to the site power supply.

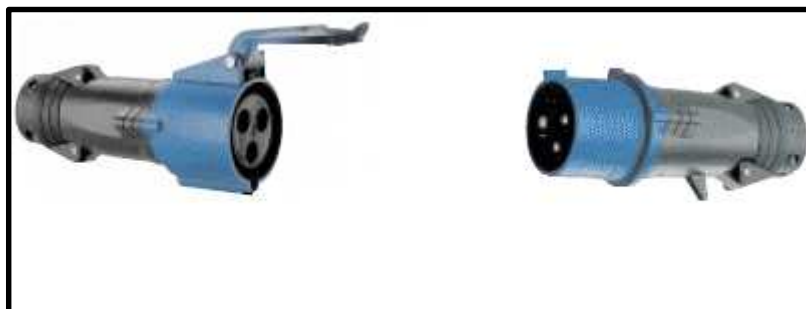

Figure 64. Power plug and socket

## Safety Recommendations



### CAUTION:

**Only duly certified electricians may connect the PDU to the power supply, under the Customer's responsibility.**



### DANGER

An electrical outlet that is not correctly wired could place hazardous voltage on metal parts. It is the Customer's responsibility to ensure that the outlet is correctly wired and grounded to prevent an electrical shock. Use one hand, when possible, to connect or disconnect signal cables to prevent a possible shock from touching two surfaces with different electrical potentials.



### CAUTION:

The PDU is equipped with three-wire power cables for user safety. Use these power cables with properly grounded electrical outlets to avoid electrical shock.

1. **Energy hazard: remove all jewelry before servicing.**
2. **Check that the dedicated power supply circuit breakers are OFF.**

## Mounting the PDU Power Cable Socket

1. Check that the power supply cable is not live with the multimeter.
2. Carefully guide the PDU power supply cable through the cable inlet at the base of the cabinet.
3. Check that the power supply cable is long enough for connection to the PDU.
4. Unscrew the base of the socket (A), insert the cable through the socket base (B), and wire to the socket head, as shown below.



Figure 65. PDU power socket

5. Screw the socket base back to the socket head (C).
6. Check for  $\leq 0.1$  ohm resistance between the grounding pin on the power cable plug and the metal frame with the multimeter.
7. Connect the power supply cable socket to the PDU power cable plug.
8. Use appropriate fasteners to secure the cable into place along the cabinet frame.

The PDU can now be connected to the site power supply.



---

## Appendix A. Specifications

This appendix gives detailed specifications for all cabinet and PDU models.

- 1300H Cabinet Specifications, on page A-2
- 1100H Cabinet Specifications, on page A-4
- 1300L Cabinet Specifications, on page A-6
- 1100L Cabinet Specifications, on page A-8
- PDU-4-2-M-63A Specifications, on page A-10
- PDU-2-4-M-32A Specifications, on page A-11
- PDU-0-7-M-32A Specifications, on page A-12

## 1300H Cabinet / 1300H-E Cabinet Specifications

<b>Dimensions / Weight</b>			
<b>Unpacked</b>		<b>Packed</b>	
Height:	195.5 cm (77.0 in)	Height:	200.0 cm (78.7 in)
Width:	60.0 cm (23.6 in)	Width:	80.0 cm (31.5 in)
Depth:	129.5 cm (51.0 in)	Depth:	140.0 cm (55.1 in)
Weight (empty):	143 kg (315 lb)	Weight (empty):	173 kg (382 lb)
Weight (full max.):	943 kg (2079 lb)	Weight (full max.):	973 kg (2145 lb)
Maximum load:	800 kg (1764 lb)		
<b>Service Clearance</b>			
Front		150 cm	
Rear		100 cm	
Side (left and right)		100 cm	
<b>Operating Mode (on levelers)</b>			
<b>Sinusoidal vibrations</b>			
Duration:	1 sweep, 1 octave/mn		
5 - 16 Hz range:	0.25 mm peak		
16 -200 Hz range:	0.25 g peak		
<b>Random excitation</b>			
Duration:	15 mn		
Frequency:	5 - 200 Hz		
Spectral density:	1.5x10 <sup>-4</sup> g <sup>2</sup> /Hz		
Root mean square acceleration:	0.17g RMS		
<b>Stability</b>			
EN60950-1			
<b>NongOperating Mode (on casters)</b>			
Sweep sine			
Duration:	1 sweep, 1 octave/mn		
5 - 16 Hz range:	0.25 mm peak		
16 - 200 Hz range:	0.25 g peak		
Random excitation			
Duration:	15 mn		
Frequency:	5 - 200 Hz		
Spectral density:	1.5x10 <sup>-3</sup> g <sup>2</sup> /Hz		
Root mean square acceleration:	0.54g RMS		
Shock tests			
Duration:	11 ms		
Form:	1/2 sinusoidal		
Amplitude:	15 g		
<b>Shipping Limits (NF ISO 2233)</b>			
Temperature:	20°C		
Relative Humidity:	65%		

Table 1. 1300H Cabinet / 1300H-E Cabinet Specifications

## 1100H Cabinet / 1100H-E Cabinet Specifications

<b>Dimensions / Weight</b>			
<b>Unpacked</b>		<b>Packed</b>	
Height:	195.5 cm (77.0 in)	Height:	200.0 cm (78.7 in)
Width:	60.0 cm (23.6 in)	Width:	80.0 cm (31.5 in)
Depth:	111.5 cm (43.9 in)	Depth:	122.0 cm (55.1 in)
Weight (empty):	135 kg (298 lb)	Weight (empty):	165 kg (364 lb)
Weight (full max.):	935 kg (2062 lb)	Weight (full max.):	965 kg (2128 lb)
Maximum load:	800 kg (1764 lb)		
<b>Service Clearance</b>			
Front		150 cm	
Rear		100 cm	
Side (left and right)		100 cm	
<b>Operating Mode (on levelers)</b>			
<b>Sinusoidal vibrations</b>			
Duration:	1 sweep, 1 octave/mn		
5 - 16 Hz range:	0.25 mm peak		
16 -200 Hz range:	0.25 g peak		
<b>Random excitation</b>			
Duration:	15 mn		
Frequency:	5 - 200 Hz		
Spectral density:	1.5x10 <sup>-4</sup> g <sup>2</sup> /Hz		
Root mean square acceleration:	0.17g RMS		
<b>Stability</b>			
EN60950-1			
<b>NongOperating Mode (on casters)</b>			
<b>Sweep sine</b>			
Duration:	1 sweep, 1 octave/mn		
5 - 16 Hz range:	0.25 mm peak		
16 - 200 Hz range:	0.25 g peak		
<b>Random excitation</b>			
Duration:	15 mn		
Frequency:	5 - 200 Hz		
Spectral density:	1.5x10 <sup>-3</sup> g <sup>2</sup> /Hz		
Root mean square acceleration:	0.54g RMS		
<b>Shock tests</b>			
Duration:	11 ms		
Form:	1/2 sinusoidal		
Amplitude:	15 g		
<b>Shipping Limits (NF ISO 2233)</b>			
Temperature:	20°C		
Relative Humidity:	65%		

Table 2. 1100H Cabinet / 1100H-E Cabinet

## 1300L Cabinet / 1300L-E Cabinet Specifications

<b>Dimensions / Weight</b>			
<b>Unpacked</b>		<b>Packed</b>	
Height:	103.5 cm (40.7 in)	Height:	108.0 cm (42.5 in)
Width:	60.0 cm (23.6 in)	Width:	80.0 cm (31.5 in)
Depth:	129.5 cm (51.0 in)	Depth:	140.0 cm (55.1 in)
Weight (empty):	98 kg (216 lb)	Weight (empty):	128 kg (282 lb)
Weight (full max.):	478 kg (1054 lb)	Weight (full max.):	508 kg (1120 lb)
Maximum load:	380 kg (838 lb)		
<b>Service Clearance</b>			
Front		150 cm	
Rear		100 cm	
Side (left and right)		100 cm	
<b>Operating Mode (on levelers)</b>			
<b>Sinusoidal vibrations</b>			
Duration:	1 sweep, 1 octave/mn		
5 - 16 Hz range:	0.25 mm peak		
16 -200 Hz range:	0.25 g peak		
<b>Random excitation</b>			
Duration:	15 mn		
Frequency:	5 - 200 Hz		
Spectral density:	1.5x10 <sup>-4</sup> g <sup>2</sup> /Hz		
Root mean square acceleration:	0.17g RMS		
<b>Stability</b>			
EN60950-1			
<b>NongOperating Mode (on casters)</b>			
Sweep sine			
Duration:	1 sweep, 1 octave/mn		
5 - 16 Hz range:	0.25 mm peak		
16 - 200 Hz range:	0.25 g peak		
Random excitation			
Duration:	15 mn		
Frequency:	5 - 200 Hz		
Spectral density:	1.5x10 <sup>-3</sup> g <sup>2</sup> /Hz		
Root mean square acceleration:	0.54g RMS		
Shock tests			
Duration:	11 ms		
Form:	1/2 sinusoidal		
Amplitude:	15 g		
<b>Shipping Limits (NF ISO 2233)</b>			
Temperature:	20°C		
Relative Humidity:	65%		

Table 3. 1300L Cabinet / 1300L-E Cabinet Specifications

## 1100L Cabinet / 1100L-E Cabinet Specifications

<b>Dimensions / Weight</b>			
<b>Unpacked</b>		<b>Packed</b>	
Height:	103.5 cm (40.7 in)	Height:	108.0 cm (42.5 in)
Width:	60.0 cm (23.6 in)	Width:	80.0 cm (31.5 in)
Depth:	111.5 cm (43.9 in)	Depth:	122.0 cm (55.1 in)
Weight (empty):	91 kg (201 lb)	Weight (empty):	121 kg (267 lb)
Weight (full max.):	471 kg (1038 lb)	Weight (full max.):	501 kg (1105 lb)
Maximum load:	380 kg (838 lb)		
<b>Service Clearance</b>			
Front		150 cm	
Rear		100 cm	
Side (left and right)		100 cm	
<b>Operating Mode (on levelers)</b>			
<b>Sinusoidal vibrations</b>			
Duration:	1 sweep, 1 octave/mn		
5 - 16 Hz range:	0.25 mm peak		
16 -200 Hz range:	0.25 g peak		
<b>Random excitation</b>			
Duration:	15 mn		
Frequency:	5 - 200 Hz		
Spectral density:	1.5x10 <sup>-4</sup> g <sup>2</sup> /Hz		
Root mean square acceleration:	0.17g RMS		
<b>Stability</b>			
EN60950-1			
<b>NongOperating Mode (on casters)</b>			
Sweep sine			
Duration:	1 sweep, 1 octave/mn		
5 - 16 Hz range:	0.25 mm peak		
16 - 200 Hz range:	0.25 g peak		
Random excitation			
Duration:	15 mn		
Frequency:	5 - 200 Hz		
Spectral density:	1.5x10 <sup>-3</sup> g <sup>2</sup> /Hz		
Root mean square acceleration:	0.54g RMS		
Shock tests			
Duration:	11 ms		
Form:	1/2 sinusoidal		
Amplitude:	15 g		
<b>Shipping Limits (NF ISO 2233)</b>			
Temperature:	20°C		
Relative Humidity:	65%		



Table 4. 1100L Cabinet / 1100L-E Cabinet

## PDU-4-2-M-63A Specifications

<b>Dimensions / Weight</b>	
Height	4.1 cm (1.6 in)
Width	48.3 cm (19 in)
Depth	12 cm (4.7 in)
Weight	2 kg (4.4 lb)
<b>Outlets</b>	
14.5 (C19)	4
9 (C13)	2
<b>Power Cables</b>	
AC (63)	1 per PDU
Mains cable type	3 x AWG06
Mains plug type	IEC60309-63A
Mains socket type	IEC60309-63A
<p><b>It is mandatory for power lines and terminal boxes to be located within the immediate vicinity of the system and to be easily accessible. Each power line must be connected to a separate, independent electrical panel and bipolar circuit breaker.</b></p> <p><b>France:</b>  <b>Power sockets and plugs must be compliant with Decree 88-1056 Article 20-IV, dated 14th November 1988.</b></p>	
<b>Electrical Specifications</b>	
<b>Europe</b>	
Nominal voltage	230 VAC (Phase / Neutral)
Voltage range	207 - 244 VAC
Frequency	50 Hz $\pm$ 1%
<b>United States of America</b>	
Nominal voltage	208 VAC (Phase / Neutral)
Voltage range	182 - 229 VAC
Frequency	60 Hz $\pm$ 0.3%
<b>Japan</b>	
Nominal voltage	200 VAC (Phase / Neutral)
Voltage range	188 - 212 VAC
Frequency	60 Hz $\pm$ 0.2%
<b>Brazil</b>	
Nominal voltage	220 VAC (Phase / Neutral)
Voltage range	212 - 231 VAC
Frequency	60 Hz $\pm$ 2%
<b>Breaker Protection</b>	
Maximum current	63A
Maximum voltage	250 VAC

Table 5. PDU-4-2-M-63A specifications

## PDU-2-4-M-32A

<b>Dimensions / Weight</b>	
Height	4.1 cm (1.6 in)
Width	48.3 cm (19 in)
Depth	12 cm (4.7 in)
Weight	2 kg (4.4 lb)
<b>Outlets</b>	
14.5 (C19)	2
9 (C13)	4
<b>Power Cables</b>	
AC (32)	1 per PDU
Mains cable type	3 x AWG10
Mains plug type	IEC60309-32A
Mains socket type	IEC60309-32A
<b>It is mandatory for power lines and terminal boxes to be located within the immediate vicinity of the system and to be easily accessible. Each power line must be connected to a separate, independent electrical panel and bipolar circuit breaker.</b>	
<b>Electrical Specifications</b>	
<b>Europe</b>	
Nominal voltage	230 VAC (Phase / Neutral)
Voltage range	207 - 244 VAC
Frequency	50 Hz $\pm$ 1%
<b>United States of America</b>	
Nominal voltage	208 VAC (Phase / Neutral)
Voltage range	182 - 229 VAC
Frequency	60 Hz $\pm$ 0.3%
<b>Japan</b>	
Nominal voltage	200 VAC (Phase / Neutral)
Voltage range	188 - 212 VAC
Frequency	60 Hz $\pm$ 0.2%
<b>Brazil</b>	
Nominal voltage	220 VAC (Phase / Neutral)
Voltage range	212 - 231 VAC
Frequency	60 Hz $\pm$ 2%
<b>Breaker Protection</b>	
Maximum current	32A
Maximum voltage	250VAC

Table 6. PDU-2-4-M-32A specifications

## PDU-0-7-M-32A

<b>Dimensions / Weight</b>	
Height	4.35 cm (1.6 in)
Width	48.3 cm (19 in)
Depth	12 cm (4.7 in)
Weight	2 kg (4.4 lb)
<b>Outlets</b>	
14.5 (C19)	0
9 (C13)	7
<b>Power Cables</b>	
AC (32)	1 per PDU
Mains cable type	3 x AWG10
Mains plug type	IEC60309-32A
Mains socket type	IEC60309-32A
<b>It is mandatory for power lines and terminal boxes to be located within the immediate vicinity of the system and to be easily accessible. Each power line must be connected to a separate, independent electrical panel and bipolar circuit breaker.</b>	
<b>Electrical Specifications</b>	
<b>Europe</b>	
Nominal voltage	230 VAC (Phase / Neutral)
Voltage range	207 - 244 VAC
Frequency	50 Hz $\pm$ 1%
<b>United States of America</b>	
Nominal voltage	208 VAC (Phase / Neutral)
Voltage range	182 - 229 VAC
Frequency	60 Hz $\pm$ 0.3%
<b>Japan</b>	
Nominal voltage	200 VAC (Phase / Neutral)
Voltage range	188 - 212 VAC
Frequency	60 Hz $\pm$ 0.2%
<b>Brazil</b>	
Nominal voltage	220 VAC (Phase / Neutral)
Voltage range	212 - 231 VAC
Frequency	60 Hz $\pm$ 2%
<b>Breaker Protection</b>	
Maximum current	32A
Maximum voltage	250VAC

Table 7. PDU-0-7-M-32A specifications

## PDU-0-12-M-32A

<b>Dimensions / Weight</b>	
Height	4.1 cm (1.7 in)
Width	48.3 cm (19 in)
Depth	25 cm (9.8 in) / 30 cm (11.8 in) with lugs
Weight	4.5 kg (9.9 lb)
<b>Outlets</b>	
14.5 (C19)	0
9 (C13)	12
<b>Power Cables</b>	
AC (24)	1 per PDU
Mains cable type	3 x AWG10
Mains plug type	IEC60309-32A
Mains socket type	IEC60309-32A
<b>It is mandatory for power lines and terminal boxes to be located within the immediate vicinity of the system and to be easily accessible. Each power line must be connected to a separate, independent electrical panel and bipolar circuit breaker.</b>	
<b>Electrical Specifications</b>	
<b>Europe</b>	
Nominal voltage	250 VAC (Phase / Neutral)
Voltage range	207 - 244 VAC
Frequency	50 Hz $\pm$ 1%
<b>Brazil</b>	
Nominal voltage	220 VAC (Phase / Neutral)
Voltage range	212 - 231 VAC
Frequency	60 Hz $\pm$ 2%
<b>Breaker Protection</b>	
Maximum current	24A
Maximum voltage	250VAC

Table 8. PDU-0-12-M-24A specifications



---

## Appendix B. Regulatory Statements and Disclaimers

---

### Declaration of the Manufacturer or Importer

We hereby certify that this product is in compliance with European Union EMC Directive 89/336/EEC, using standards EN55022 (Class A) and EN55024 and Low Voltage Directive 73/23/EEC, using standard EN60950. The product has been marked with the CE Mark to illustrate its compliance.

---

### Safety Compliance Statement

- UL 60950 (USA)
- IEC 60950 (International)
- CSA 60950 (Canada)

---

### European Community (EC) Council Directives

This product is in conformity with the protection requirements of the following EC Council Directives:

#### Electromagnetic Compatibility

- 89/336/EEC

#### Low Voltage

- 73/23/EEC

#### EC Conformity

- 93/68/EEC

#### Telecommunications Terminal Equipment

- 1999/5/EC

Neither the provider nor the manufacturer can accept responsibility for any failure to satisfy the protection requirements resulting from a non-recommended modification of the product.

Compliance with these directives requires:

- an EC declaration of conformity from the manufacturer
- an EC label on the product
- technical documentation

---

## Federal Communications Commission (FCC) Statement

 **Note:**

This equipment has been tested and found to comply with the limits for a Class A digital device, pursuant to Part 15 of the FCC Rules. These limits are designed to provide reasonable protection against harmful interference when the equipment is operated in a commercial environment. This equipment generates, uses, and can radiate radio frequency energy and, if not installed and used in accordance with the instruction manual, may cause harmful interference to radio communications. Operation of this equipment in a residential area is likely to cause harmful interference in which case the user will be required to correct the interference at his own expense.

Properly shielded and grounded cables and connectors must be used in order to meet FCC emission limits. Neither the provider nor the manufacturer are responsible for any radio or television interference caused by using other than recommended cables and connectors or by unauthorized changes or modifications to this equipment. Unauthorized changes or modifications could void the user's authority to operate the equipment.

Any changes or modifications not expressly approved by the grantee of this device could void the user's authority to operate the equipment. The customer is responsible for ensuring compliance of the modified product.

---

## FCC Declaration of Conformity

This device complies with Part 15 of the FCC Rules. Operation is subject to the following two conditions: (1) this device may not cause harmful interference, and (2) this device must accept any interference received, including interference that may cause undesired operation.

---

## Canadian Compliance Statement (Industry Canada)

This Class A digital apparatus meets all requirements of the Canadian Interference Causing Equipment Regulations.

Cet appareil numérique de la classe A est conforme à la norme NMB-003 du Canada.

This product is in conformity with the protection requirements of the following standards:

### Electromagnetic Compatibility

- ICES-003
- NMB-003

---

## Laser Compliance Notice

This product that uses laser technology complies with Class 1 laser requirements.

A CLASS 1 LASER PRODUCT label is located on the laser device.

<p><b>Class 1 Laser Product</b> <b>Luokan 1 Laserlaitte</b> <b>Klasse 1 Laser Apparat</b> <b>Laser Klasse 1</b></p>
---



---

## Appendix C. Safety Notices



**Important:**

You are requested to carefully read the Safety Notices set out in this appendix before installing or servicing cabinets.

The documentation delivered with rack-mountable servers and devices may contain important safety information. You are requested to carefully read the Safety Notices set out in this documentation before installing or servicing rack-mountable servers and/or devices.

---

### Definition of Safety Notices



**DANGER**

A *Danger* notice indicates the presence of a hazard that has the potential of causing death or serious personal injury.



**CAUTION:**

A *Caution* notice indicates the presence of a hazard that has the potential of causing moderate or minor personal injury.



**Warning:**

A *Warning* notice indicates an action that could cause damage to a program, device, system, or data.

---

## General Safety Notices

The following safety instructions must be observed at all times.



### **DANGER**

- **Jacking screws must always be lowered.**
- **Stabilizers must always be installed.**
- **Servers and devices must always be fitted in the cabinet from the bottom upwards.**
- **Servers and devices must be fitted in the cabinet so that the air-flow is from front to back: all fans blowing towards the rear of the cabinet.**
- **Never slide more than one server or device out of the rack at a time.**
- **Slide-mounted servers and devices must not exceed 20 kg (44 lbs).**
- **Thermal dissipation must not exceed 400 W per U mean, 700 W per U peak.**
- **Firmly secure servers and devices to the mounting columns at the front and rear of the cabinet.**
- **Always use the mounting fixtures supplied with the servers and/or devices.**



### **CAUTION:**

- Regularly check covers and doors for damage and sharp edges.
- Regularly check cables for damage.
- Comply with standard protection procedures when handling static-sensitive devices:
  - Systematically wear an anti-static wrist strap.
  - Touch the cabinet frame to release static before installing servers or devices.
  - Only remove devices from anti-static containers when you are ready to install them in the cabinet.



### **Warning:**

**The cabinet must be stowed in shock-resistant packing and shipped by road, rail, sea, or air.**

---

## Electrical Safety Notices

The following safety instructions must be observed when connecting or disconnecting devices to the system.



### **DANGER**

**The Customer is responsible for ensuring that the AC electricity supply is compliant with national and local recommendations, regulations, standards and codes of practice. An incorrectly wired and grounded electrical outlet may place hazardous voltage on metal parts of the system or the devices that attach to the system and result in an electrical shock. It is mandatory to remove power cables from electrical outlets before relocating the system.**

- **The Customer is responsible for ensuring that the AC electricity supply is compliant with national and local recommendations, regulations, standards and codes of practice.**
- **Power cables must be connected to properly wired and grounded electrical outlets.**
- **Power cables must be disconnected from electrical outlets before relocating the cabinet.**
- **Power cables must be disconnected from electrical outlets before servicing servers and devices.**
- **Servers and devices in a cabinet must be connected to power distribution units (PDUs) in the same cabinet.**



---

## Index

### C

#### Cabinet

- 1100H, 1-4
- 1100L, 1-6
- 1300H, 1-3
- 1300L, 1-5
- extension, 2-29
- hoisting, 2-15
- inspecting, 2-6
- jacking screws, 2-16
- models, 1-2
- moving, 2-14
- packing, 2-3
- relocating, 2-14
- rolling, 2-14
- securing, 2-16
- service clearance, 2-7
- shipping pallet, 2-8
- specifications, A-1
- stabilizer, 2-17
- unloading, 2-7

#### Cables

- data, 3-2
- inter-cabinet, 3-2
- power, 3-3
- routing, 3-3

#### Compatibility, server / device, 2-33

#### Connecting, PDU, 3-3

#### Covers

- installing, 2-20
- removing, 2-20

### D

#### Data, cables, 3-2

#### Data cables, routing, 3-2

#### Devices, installing, 2-32

#### Doors

- installing, 2-20
- removing, 2-20

### E

#### Electrical safety, C-3

#### Equipment tray, fitting, 2-37

#### Extension, adding, 2-29

### F

#### Flange hole, size, 2-33

#### Front door

- installing, 2-20
- removing, 2-20

### I

#### Installing

- devices, 2-32
- PDU, 2-44
- servers, 2-32

#### Integration kit

- installing, 2-34
- server / device, installing, 2-34

#### Inter-cabinet cables, routing, 3-2

### J

#### Jacking screws, lowering, 2-16

### L

#### Labels

- shockwatch, 2-4
- tiltwatch, 2-4

### M

#### Models

- cabinet, 1-2
- PDU, 1-7

### N

#### Notices

- electrical safety, C-3
- safety, C-1

### P

#### Packing

- cabinet, 2-3
- inspecting, 2-4
- removing, 2-5
- storing, 2-5

#### PDU

- connecting, 3-3
- installing, 2-44
- models, 1-7
- specifications, A-1

#### PDU model

- PDU-0-12-M-32A, 1-11
- PDU-2-4-M-32A, 1-9
- PDU-4-2-M-63A, 1-8

#### PDU models, PDU-0-7-M-32A, 1-10

#### Power cables, PDU, 3-4

#### Power supply, connecting a PDU, 3-3

### R

#### Rear door

- installing, 2-20
- removing, 2-20

#### Relocating, cabinet, 2-14

#### Routing

- data cables, 3-2
- inter-cabinet cables, 3-2
- power cables, 3-3

### S

#### Safety

- notices, C-1
- recommendations, 3-3

- Server / Device, compatibility, 2-33
- Server components, PDU power cable, 3-4
- Servers, installing, 2-32
- Service clearance, cabinet, 2-7
- Shipping pallet, removing, 2-8
- Shockwatch, labels, 2-4
- Side panels
  - installing, 2-22
  - removing, 2-22
- Spacer, top, 2-31
- Spacers
  - front, 2-29
  - rear, 2-30
- Specifications
  - cabinet, A-1
  - PDU, A-1
- Stabilizer
  - installing, 2-17
  - lowering, 2-19

- raising, 2-19

## T

- Tiltwatch, labels, 2-4
- Tools, unloading, 2-8
- Top cover
  - installing
    - 1300H/1100H, 2-24
    - 1300L/1100L, 2-26
  - removing
    - 1300H/1100H, 2-24
    - 1300L/1100L, 2-26

## U

- Unloading
  - cabinet, 2-7
  - removing shipping pallet, 2-8
  - tools, 2-8

## Technical publication remarks form

<b>Title :</b>	1100 AND 1300 CABINET Installation and Service Guide
----------------	--

<b>Reference:</b>	86 A1 91EM 03
-------------------	---------------

<b>Date:</b>	October 2006
--------------	--------------

### ERRORS IN PUBLICATION

--

### SUGGESTIONS FOR IMPROVEMENT TO PUBLICATION

--

Your comments will be promptly investigated by qualified technical personnel and action will be taken as required.  
If you require a written reply, please include your complete mailing address below.

NAME : \_\_\_\_\_ Date : \_\_\_\_\_

COMPANY : \_\_\_\_\_

ADDRESS : \_\_\_\_\_

Please give this technical publication remarks form to your BULL representative or mail to:

Bull - Documentation Dept.  
1 Rue de Provence  
BP 208  
38432 ECHIROLLES CEDEX  
FRANCE  
info@frec.bull.fr

# Technical publications ordering form

To order additional publications, please fill in a copy of this form and send it via mail to:

**BULL CEDOC**  
**357 AVENUE PATTON**  
**B.P.20845**  
**49008 ANGERS CEDEX 01**  
**FRANCE**

**Phone:** +33 (0) 2 41 73 72 66  
**FAX:** +33 (0) 2 41 73 70 66  
**E-Mail:** [srv.Duplicopy@bull.net](mailto:srv.Duplicopy@bull.net)

Reference	Designation	Qty
-- -- [ ]		
-- -- [ ]		
-- -- [ ]		
-- -- [ ]		
-- -- [ ]		
-- -- [ ]		
-- -- [ ]		
-- -- [ ]		
-- -- [ ]		
-- -- [ ]		
-- -- [ ]		
-- -- [ ]		
-- -- [ ]		
[ ] : The latest revision will be provided if no revision number is given.		

NAME: \_\_\_\_\_ Date: \_\_\_\_\_

COMPANY: \_\_\_\_\_

ADDRESS: \_\_\_\_\_

PHONE: \_\_\_\_\_ FAX: \_\_\_\_\_

E-MAIL: \_\_\_\_\_

**For Bull Subsidiaries:**

Identification: \_\_\_\_\_

**For Bull Affiliated Customers:**

Customer Code: \_\_\_\_\_

**For Bull Internal Customers:**

Budgetary Section: \_\_\_\_\_

**For Others: Please ask your Bull representative.**





**BULL CEDOC**  
**357 AVENUE PATTON**  
**B.P.20845**  
**49008 ANGERS CEDEX 01**  
**FRANCE**

REFERENCE  
**86 A1 91EM 03**

Utiliser les marques de découpe pour obtenir les étiquettes.  
Use the cut marks to get the labels.



**1100 AND  
1300 CABINET**

Installation and  
Service Guide

86 A1 91EM 03



**1100 AND  
1300 CABINET**

Installation and  
Service Guide

86 A1 91EM 03



**1100 AND  
1300 CABINET**

Installation and  
Service Guide

86 A1 91EM 03



