

R@ck'n Roll & R@ck-to-Build

Installation and Service Guide

R@CK'N ROLL &
R@CK-TO-BUILD



REFERENCE
86 A1 17FA 00

R@CK'N ROLL & R@CK-TO-BUILD

R@ck'n Roll & R@ck-to-Build

Installation and Service Guide

Hardware

May 2008

Bull Cedoc
357 avenue Patton
BP 20845
49008 Angers Cedex 01
FRANCE

REFERENCE
86 A1 17FA 00

The following copyright notice protects this book under Copyright laws which prohibit such actions as, but not limited to, copying, distributing, modifying, and making derivative works.

Copyright ©Bull SAS 2008

Printed in France

Suggestions and criticisms concerning the form, content, and presentation of this book are invited. A form is provided at the end of this book for this purpose.
--

Trademarks and Acknowledgements

We acknowledge the right of proprietors of trademarks mentioned in this manual.

All brand names and software and hardware product names are subject to trademark and/or patent protection.

Quoting of brand and product names is for information purposes only and does not represent trademark misuse.

The information in this document is subject to change without notice. Bull will not be liable for errors contained herein, or for incidental or consequential damages in connection with the use of this material.

Table of Contents

Preface	vii
Intended Readers	vii
Highlighting	vii
Regulatory Specifications and Disclaimers	viii
Declaration of the Manufacturer or Importer	viii
Safety Compliance Statement	viii
European Community (EC) Council Directives	viii
Electromagnetic Compatibility	viii
Low Voltage	viii
EC Conformity	viii
Telecommunications Terminal Equipment	viii
Federal Communications Commission (FCC) Statement	ix
FCC Declaration of Conformity	ix
Canadian Compliance Statement (Industry Canada)	ix
Laser Compliance Notice	ix
Definition of Safety Notices	x
Electrical Safety	x
Laser Safety Information	xi
Data Integrity and Verification	xi
Waste Management	xi
Chapter 1. Overview	1-1
1.1. Cabinet Models	1-2
1.1.1. R@ck'n Roll Cabinet Features	1-2
1.1.2. R@ck-to-Build Cabinet Features	1-2
1.2. PDU Models	1-3
1.2.1. PDU 32A, 4xC13 - 2xC19, EU	1-4
1.2.2. PDU 24A, 4xC13 - 2xC19, US	1-4
1.2.3. PDU 63A, 2xC13 - 4xC19, EU	1-5
1.2.4. PDU 32A, 7xC13 EU	1-5
1.2.5. PDU 32A, 12xC13 EU	1-6
Chapter 2. Installing and Servicing Cabinets	2-1
2.1. General Recommendations	2-2
2.2. Inspecting Cabinet Packing	2-3
2.2.1. Warning and Shockwatch labels	2-3
2.2.2. Unpacking and Depalletizing label	2-5
2.3. Removing and Storing Packing Items	2-6
2.3.1. Removing Standard Packing Items	2-6
2.3.2. Removing Reinforced Packing Items	2-7

2.3.3.	Storing Packing Items	2-7
2.4.	Unloading the Cabinet	2-8
2.4.1.	Service Clearance	2-8
2.4.2.	Unpacking the R@ck'n Roll Cabinet	2-9
2.4.3.	Depalletizing the R@ck'n Roll Cabinet	2-9
2.5.	Inspecting the Cabinet	2-10
2.6.	Moving the Cabinet	2-11
2.7.	Securing the Cabinet	2-12
2.7.1.	Lowering Feet	2-12
2.8.	Removing / Installing / Turning the Doors and Side Panels	2-13
2.8.1.	Removing the Door	2-13
2.8.2.	Installing the Door	2-13
2.8.3.	Turning the Front and/or Rear Door	2-14
2.8.4.	Removing a Side Panel	2-14
2.8.5.	Installing a Side Panel	2-14
2.9.	Installing Servers and/or Devices	2-15
2.9.1.	Checking Server / Device Compatibility	2-16
2.10.	Fitting Equipment Trays	2-17
2.11.	Installing a PDU	2-18

Chapter 3.	Managing Power and Data Cables	3-1
3.1.	Routing Data Cables	3-1
3.1.1.	Routing Inter-Cabinet Data Cables	3-1
3.2.	Routing and Connecting Power Cables	3-1
3.3.	Connecting a PDU to the Site Power Supply	3-2
3.3.1.	Safety Recommendations	3-2
3.3.2.	Mounting the PDU Power Cable Socket	3-2

Appendix A.	Specifications	A-1
A.1.	R@ck'n Roll Cabinet Specifications	A-2
A.2.	R@ck-to-Build Cabinet Specifications	A-2
A.3.	PDU Common Electrical Specifications	A-3
A.4.	PDU 63A, 2xC13 - 4xC19, EU Specifications	A-4
A.5.	PDU 32A, 4xC13 - 2xC19, EU Specifications	A-4
A.6.	PDU 32A, 7xC13 EU Specifications	A-5
A.7.	PDU 32A, 12xC13 EU Specifications	A-5
A.8.	PDU 24A, 4xC13 - 2xC19, US Specifications	A-6

Glossary	g-1
-----------------------	------------

Index	x-1
--------------------	------------

List of Figures

Figure 1.	Cabinet features	1-2
Figure 2.	PDU 32A, 4xC13 - 2xC19, EU features -vertical / horizontal installation	1-4
Figure 3.	PDU 24A, 4xC13 - 2xC19, US features -vertical / horizontal installation	1-4
Figure 4.	PDU 63A, 2xC13 - 4xC19, EU features - vertical / horizontal installation	1-5
Figure 5.	PDU 32A, 7xC13 EU features - vertical / horizontal installation	1-5
Figure 6.	PDU 32A, 12xC13 EU features - vertical/horizontal installation	1-6
Figure 7.	Packing Warning Label	2-3
Figure 8.	Packing shockwatch label	2-4
Figure 9.	R@ck'n Roll Cabinet Unpacking and Depalletizing label	2-5
Figure 10.	Removing standard packing items	2-6
Figure 11.	Removing reinforced packing items	2-7
Figure 12.	Required unpacking area	2-8
Figure 13.	Cabinet service clearance	2-11
Figure 14.	Internal cabinet dimensions	2-16
Figure 15.	Mounting flange hole size and placement	2-17
Figure 16.	Installing a PDU vertically	2-18
Figure 17.	Installing a PDU horizontally	2-19
Figure 18.	Power plug and socket	3-2
Figure 19.	PDU power socket	3-3

List of Tables

Table 1.	R@ck'n Roll Cabinet Specifications	3-2
Table 2.	R@ck-to-Build Cabinet Specifications	3-2
Table 3.	PDU common specifications	3-3
Table 4.	PDU 63A, 2xC13 - 4xC19, EU specifications	3-4
Table 5.	PDU 32A, 4xC13 - 2xC19, EU specifications	3-4
Table 6.	PDU 32A, 7xC13 EU specifications	3-5
Table 7.	PDU 32A, 12xC13 EU specifications	3-5
Table 8.	PDU 24A, 4xC13 - 2xC19, US specifications	3-6

Preface

Intended Readers

This guide is intended for use by qualified personnel in charge of installing and servicing Bull R@ck'n Roll and R@ck-to-Build Cabinets.



Important

Detailed installation and servicing instructions for rack-mountable servers and/or devices are provided in the documentation delivered with these servers and/or devices.

Chapter 1 Overview describes cabinet features.

Chapter 2 Installing and Servicing Cabinets explains how to unpack, install, and service the cabinets.

Chapter 3 Managing Power and Data Cables explains how to route and connect power and data cables inside the cabinets.

Appendix A Specifications gives detailed specifications for all cabinet and PDU models



DANGER

Personnel are requested to carefully read the Safety Notices set out in Appendix A before installing or servicing cabinets.

Highlighting

The following highlighting conventions are used in this guide:

Bold	Identifies the following: <ul style="list-style-type: none">• Interface objects such as menu names, labels, buttons and icons.• File, directory and path names.• Keywords to which particular attention must be paid.
<i>Italics</i>	Identifies references such as manuals or URLs.
<code>monospace</code>	Identifies portions of program codes, command lines, or messages displayed in command windows.
< >	Identifies parameters to be supplied by the user.

Regulatory Specifications and Disclaimers

Declaration of the Manufacturer or Importer

We hereby certify that this product is in compliance with European Union EMC Directive 2004/108/CE, using standards EN55022 (Class A) and EN55024 and Low Voltage Directive 2006/95/CE, using standard EN60950. The product has been marked with the CE Mark to illustrate its compliance.

Safety Compliance Statement

- UL 60950 (USA)
- IEC 60950 (International)
- CSA 60950 (Canada)

European Community (EC) Council Directives

This product is in conformity with the protection requirements of the following EC Council Directives:

Electromagnetic Compatibility

- 2004/108/CE

Low Voltage

- 2006/95/CE

EC Conformity

- 93/68/EEC

Telecommunications Terminal Equipment

- 1999/5/EC

Neither the provider nor the manufacturer can accept responsibility for any failure to satisfy the protection requirements resulting from a non-recommended modification of the product.

Compliance with these directives requires:

- An EC declaration of conformity from the manufacturer.
- An EC label on the product.
- Technical documentation.

Federal Communications Commission (FCC) Statement

Note This equipment has been tested and found to comply with the limits for a Class A digital device, pursuant to Part 15 of the FCC Rules. These limits are designed to provide reasonable protection against harmful interference when the equipment is operated in a commercial environment. This equipment generates, uses, and can radiate radio frequency energy and, if not installed and used in accordance with the instruction manual, may cause harmful interference to radio communications. Operation of this equipment in a residential area is likely to cause harmful interference in which case the user will be required to correct the interference at his own expense.

Properly shielded and grounded cables and connectors must be used in order to meet FCC emission limits. Neither the provider nor the manufacturer are responsible for any radio or television interference caused by using other than recommended cables and connectors or by unauthorized changes or modifications to this equipment. Unauthorized changes or modifications could void the user's authority to operate the equipment.

Any changes or modifications not expressly approved by the grantee of this device could void the user's authority to operate the equipment. The customer is responsible for ensuring compliance of the modified product.

FCC Declaration of Conformity

This device complies with Part 15 of the FCC Rules. Operation is subject to the following two conditions: (1) this device may not cause harmful interference, and (2) this device must accept any interference received, including interference that may cause undesired operation.

Canadian Compliance Statement (Industry Canada)

This Class A digital apparatus meets all requirements of the Canadian Interference Causing Equipment Regulations.

Cet appareil numérique de la classe A est conforme à la norme NMB-003 du Canada.

This product is in conformity with the protection requirements of the following standards:

- ICES-003
- NMB-003

Laser Compliance Notice

This product that uses laser technology complies with Class 1 laser requirements.

A CLASS 1 LASER PRODUCT label is located on the laser device.

Class 1 Laser Product Luokan 1 Laserlaite Klasse 1 Laser Apparat Laser Klasse 1
--

Definition of Safety Notices



DANGER

A *Danger* notice indicates the presence of a hazard that has the potential of causing death or serious personal injury.



CAUTION

A *Caution* notice indicates the presence of a hazard that has the potential of causing moderate or minor personal injury.



WARNING

A *Warning* notice indicates an action that could cause damage to a program, device, system, or data.

Electrical Safety

The following safety instructions shall be observed when connecting or disconnecting devices to the system.



DANGER

The Customer is responsible for ensuring that the AC electricity supply is compliant with national and local recommendations, regulations, standards and codes of practice. An incorrectly wired and grounded electrical outlet may place hazardous voltage on metal parts of the system or the devices that attach to the system and result in an electrical shock. It is mandatory to remove power cables from electrical outlets before relocating the system.



CAUTION

This unit has more than one power supply cable. Follow procedures for removal of power from the system when directed.

Laser Safety Information

The optical drive in this system unit is classified as a Class 1 level Laser product. The optical drive has a label that identifies its classification.

The optical drive in this system unit is certified in the U.S. to conform to the requirements of the Department of Health and Human Services 21 Code of Federal Regulations (DHHS 21 CFR) Subchapter J for Class 1 laser products. Elsewhere, the drive is certified to conform to the requirements of the International Electrotechnical Commission (IEC) 60825-1: 2001 and CENELEC EN 60825-1: 1994 for Class 1 laser products.



CAUTION

Invisible laser radiation when open. Do not stare into beam or view directly with optical instruments.

Class 1 Laser products are not considered to be hazardous. The optical drive contains internally a Class 3B gallium-arsenide laser that is nominally 30 milliwatts at 830 nanometers. The design incorporates a combination of enclosures, electronics, and redundant interlocks such that there is no exposure to laser radiation above a Class 1 level during normal operation, user maintenance, or servicing conditions.

Data Integrity and Verification



WARNING

Full product is designed to reduce the risk of undetected data corruption or loss. However, if unplanned outages or system failures occur, users are strongly advised to check the accuracy of the operations performed and the data saved or transmitted by the system at the time of outage or failure.

Waste Management

This product has been built to comply with the Restriction of Certain Hazardous Substances (RoHS) Directive 2002/95/EC.

This product has been built to comply with the Waste Electrical and Electronic (WEEE) Directive 2002/96/EC.

Chapter 1. Overview

This chapter presents the different cabinet and power distribution unit models. It includes the following topics:

- Cabinet Models, on page 1-2
- PDU Models, on page 1-3

1.1. Cabinet Models

Two cabinet models are available: R@ck'n Roll Cabinet and R@ck-to-Build Cabinet.



Figure 1. Cabinet features

Note 1 U = 44.45 mm (1.75 in).
Maximum allowable thermal dissipation: 40 KW /42U per cabinet.

1.1.1. R@ck'n Roll Cabinet Features

The R@ck'n Roll Cabinet is 600 mm wide, 42-U high and 1100 mm deep and delivers rack-integrated, factory-assembled, ready-to-use solutions.

The R@ck'n Roll Cabinet can be shipped loaded and goes through standard doorways, once depalletized, on its castors.

1.1.2. R@ck-to-Build Cabinet Features

The R@ck-to-Build Cabinet is 600 mm wide, 42-U high and 1100 mm deep and allows customers to install equipment on site.

The R@ck-to-Build Cabinet is shipped empty and goes through standard doorways, once depalletized, on its castors.

1.2. PDU Models

The following Power Distribution Units (PDUs) are available:

- PDU 32A, 4xC13 - 2xC19, EU, on page 1-4
- PDU 24A, 4xC13 - 2xC19, US, on page 1-4
- PDU 63A, 2xC13 - 4xC19, EU, on page 1-5
- PDU 32A, 7xC13 EU, on page 1-5
- PDU 32A, 12xC13 EU, on page 1-6

According to type, the PDUs allow you to connect six, seven, or twelve servers and/or devices to a single dedicated power supply outlet.

All PDUs can be installed both vertically and horizontally in the cabinet. Refer to the documentation delivered with the PDU for detailed installation instructions.

Note See Appendix A for further details.



CAUTION

France:

Power sockets and plugs must be compliant with Decree 88-1056 Article 20-IV, dated 14th November 1988.

1.2.1. PDU 32A, 4xC13 - 2xC19, EU

The PDU 32A, 4xC13 - 2xC19, EU allows you to connect up to six servers and/or devices. It offers the following features:

Phase	Single phase	Mains Connectors	IEC60309-32A
Max. Current	32 A	9A (C13) Outlets	4
Max. Voltage	240 VAC	14.5A (C19) Outlets	2
Mains Cable	3xAWG10 (2 m lenght)	Breakers	6 (9A / C13 breaker, 14.5A /C19 breaker)



Figure 2. PDU 32A, 4xC13 - 2xC19, EU features -vertical / horizontal installation

1.2.2. PDU 24A, 4xC13 - 2xC19, US

The PDU 24A, 4xC13 - 2xC19, US allows you to connect up to six servers and/or devices. It offers the following features:

Phase	Single phase	Mains Connectors	USL6-30P-24A
Max. Current	2u A	8A (C13) Outlets	4
Max. Voltage	240 VAC	16A (C19) Outlets	2
Mains Cable	3xAWG10 (2 m lenght)	Breakers	2 (1x C13 breaker, 1x C19 breaker)



Figure 3. PDU 24A, 4xC13 - 2xC19, US features -vertical / horizontal installation

1.2.3. PDU 63A, 2xC13 - 4xC19, EU

The PDU 63A, 2xC13 - 4xC19, EU allows you to connect up to six servers and/or devices. It offers the following features:

Phase	Single phase	Mains Connectors	IEC60309-63A
Max. Current	63 A	14.5A (C19) Outlets	4
Max. Voltage	240 VAC	9A (C13) Outlets	2
Mains Cable	3xAWG06 (2 m length)	Breakers	6 (9A / C13 breaker, 14.5A /C19 breaker)



Figure 4. PDU 63A, 2xC13 - 4xC19, EU features - vertical / horizontal installation

1.2.4. PDU 32A, 7xC13 EU

The PDU 32A, 7xC13 EU allows you to connect up to seven servers and/or devices. It offers the following features:

Phase	Single phase	Mains Connectors	IEC60309-32A
Max. Current	32 A	14.5A (C19) Outlets	0
Max. Voltage	240 VAC	9A (C13) Outlets	7
Mains Cable	3xAWG10 (2 m length)	Breakers	7 (9A /C13 breaker)



Figure 5. PDU 32A, 7xC13 EU features - vertical / horizontal installation

1.2.5. PDU 32A, 12xC13 EU

The PDU 32A, 12xC13 EU allows you to connect up to twelve servers and/or devices. It offers the following features:

Phase	Single phase	Mains Connectors	IEC60309-32A
Max. Current	32 A	14.5A (C19) Outlets	0
Max. Voltage	240 VAC	9A (C13) Outlets	12
Mains Cable	3xAWG10 (2 m length)	Breakers	4 (9A /C13 breaker)



Figure 6. PDU 32A, 12xC13 EU features - vertical/horizontal installation

Chapter 2. Installing and Servicing Cabinets

This chapter explains how to unpack, install, and service the cabinets. It includes the following topics:

- General Recommendations, on page 2-2
- Inspecting Cabinet Packing, on page 2-3
- Removing and Storing Packing Items, on page 2-6
- Unloading the Cabinet, on page 2-8
- Inspecting the Cabinet, on page 2-10
- Moving the Cabinet, on page 2-11
- Securing the Cabinet, on page 2-12
- Removing / Installing / Turning the Doors and Side Panels, on page 2-13
- Installing Servers and/or Devices, on page 2-15
- Fitting Equipment Trays, on page 2-17
- Installing a PDU, on page 2-18



CAUTION

All servers and devices installed in the cabinets must be compliant with national safety regulations.

2.1. General Recommendations

Cabinets may be delivered either equipped with servers and devices or empty, according to the model chosen.

Site preparation must be completed by the pre-arranged delivery date.
Any delay due to non-completion of the site by the pre-arranged date will be considered as the Customer's responsibility.

Note R@ck'n Roll Cabinet unpacking and depalletizing instructions are clearly set out on a label attached to the cabinet door. See Figure 9. R@ck'n Roll Cabinet Unpacking and Depalletizing label, on page 2-5



CAUTION

The Data Processing Site manager must allocate enough personnel to ensure safe handling.



DANGER

The loaded R@ck'n Roll Cabinet or R@ck-to-Build Cabinet may be extremely heavy and require the use of an elevator.
It is mandatory for the loaded R@ck'n Roll Cabinet to be transported vertically.



important

The Data Processing Site manager must set aside the required working area for unpacking as shown in Figure 12. Service Clearance, on page 2-8.

2.2. Inspecting Cabinet Packing

The following packing items are used to protect cabinets during shipping:

- top, front, rear protective covers,
- pallet,
- plastic and velcro straps,
- shockwatch and tiltwatch labels.

A box, labeled **Open Me First** is delivered with each cabinet. This box contains:

- one front stabilizer and fixtures (optional),
- hoisting fixtures (optional),
- this document.

R@ck'n Roll Cabinet unpacking and depalletizing instructions are clearly set out on a label attached to the cabinet door.

2.2.1. Warning and Shockwatch labels

Before unpacking, check the indicators on the 2 shockwatch and 3 tiltwatch labels, positioned as follows on the packing:

- 1 on the front cover
- 1 on the side cover
- 1 on the outer side of the internal front door cover

If one or more of the indicators are RED, the cabinet and/or contents may be damaged. Note indicator status on the bill of lading and carefully inspect the cabinet and contents before powering up servers and devices.

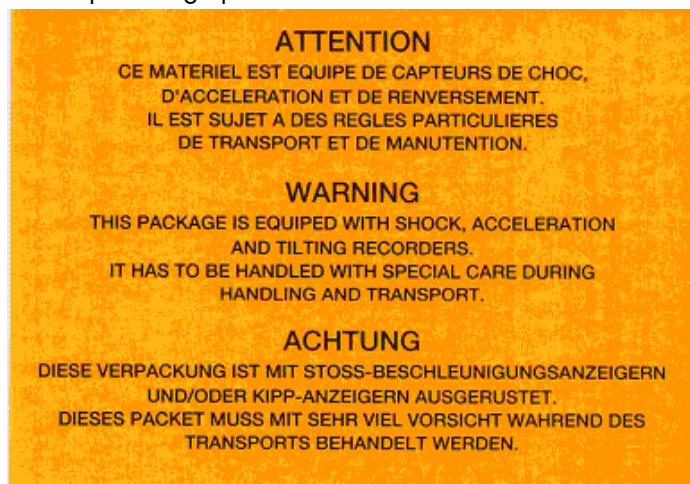

Figure 7. Packing Warning Label

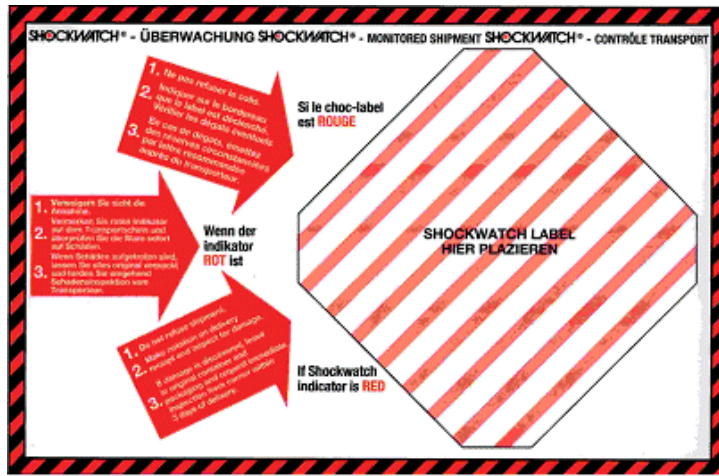

Figure 8. Packing shockwatch label

Note Check the Shockwatch label BEFORE accepting the merchandise.



CAUTION

If the Tiltwatch label is red, make a reserve on the delivery slip and check packing contents.

2.2.2. Unpacking and Depalletizing label

This label is attached on the cabinet front door and indicates the recommended way to unpack and depalletize the R@ck'n Roll Cabinet.

R@ck'nRoll CABINET: UNPACKING AND DEPALLEITIZING LABEL

1 Unpacking

TOOLING

- Standard pallet truck
- Cutter

SURFACE

- 3m x 3m = 9. m²
- Flat and horizontal



PROCEDURE

- 1 Check the indicators on the external shockwatch and tiltwatch labels.
- 2 Remove the stretch film and elastics with the cutter, taking care not to damage the cabinet.
- 3 Remove the internal protection cover.
- 4 Set packing items aside.



2 Depalletizing

TOOLING

- Cross-threaded screwdriver
- Combination wrench: 10

SURFACE

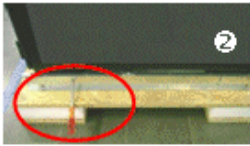
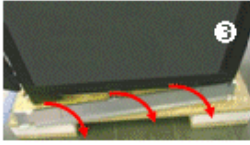
- 4m x 3m = 12. m²
- Flat and horizontal

DANGER
3 persons at least are required to depalletize the cabinet

PROCEDURE

- 1 Remove the rear door by lifting it off its hinges and set aside.
- 2 Unscrew the M6 screws, bolts and wood screws to free the 2 depalletizing rails located on either side of the pallet.
- 3 Remove the 2 depalletizing rails.
- 4 Align the 2 depalletizing rails with the rear pallet rails and holes. Secure into place with the wood screws.
- 5 Check that the cabinet feet are in the highest position and that the cabinet wheels are correctly aligned on the depalletizing rails.
- 6 Carefully roll the cabinet along the depalletizing rails and off the pallet:
 - 2 persons at least must support the cabinet on the rail side**
 - 1 person at least must guide the cabinet on the opposite side**
- 7 Move the cabinet to the required location and lower the feet to secure it



86 X1 18FA 00

Figure 9. R@ck'n Roll Cabinet Unpacking and Depalletizing label

2.3. Removing and Storing Packing Items



WARNING

To avoid condensation and incorrect handling, cabinets must be removed from their packing by authorized Service personnel ONLY, on the scheduled installation date.

Use the Packing Slip to check the number and condition of the shipping boxes prior to unpacking.

Two types of packing are available, according to shipping conditions:

- standard packing, for short-distance deliveries,
- reinforced packing, for long-distance deliveries.

2.3.1. Removing Standard Packing Items

Tools Required

- Cutter



Figure 10. Removing standard packing items

1. Unfasten and remove the stoppers surrounding the cabinet.
2. Remove the stretch film / condensation barrier packing.

2.3.2. Removing Reinforced Packing Items

Tools Required

- Cutter



Figure 11. Removing reinforced packing items

1. Cut the plastic straps with the cutter.
2. Remove the top cover.
3. Remove the rear and front covers by opening the plastic fasteners.
4. Unfasten and remove the stoppers surrounding the cabinet.
5. Remove the stretch film / condensation barrier packing.

2.3.3. Storing Packing Items

All packing items are to be stored in an ancillary room for re-use in the event of relocation or shipping.

2.4. Unloading the Cabinet

The cabinet is delivered on a pallet for easy unloading. It can then be transported on its castors.

Notes

- The R@ck-to-Build Cabinet can be unloaded and installed by lifting it off the pallet and rolling into place.
- The R@ck'n Roll Cabinet must be unloaded following the instructions set out below and on the label attached to the cabinet door.

2.4.1. Service Clearance

The Data Processing Site manager must set aside the required working area for unpacking as shown in the following figure.

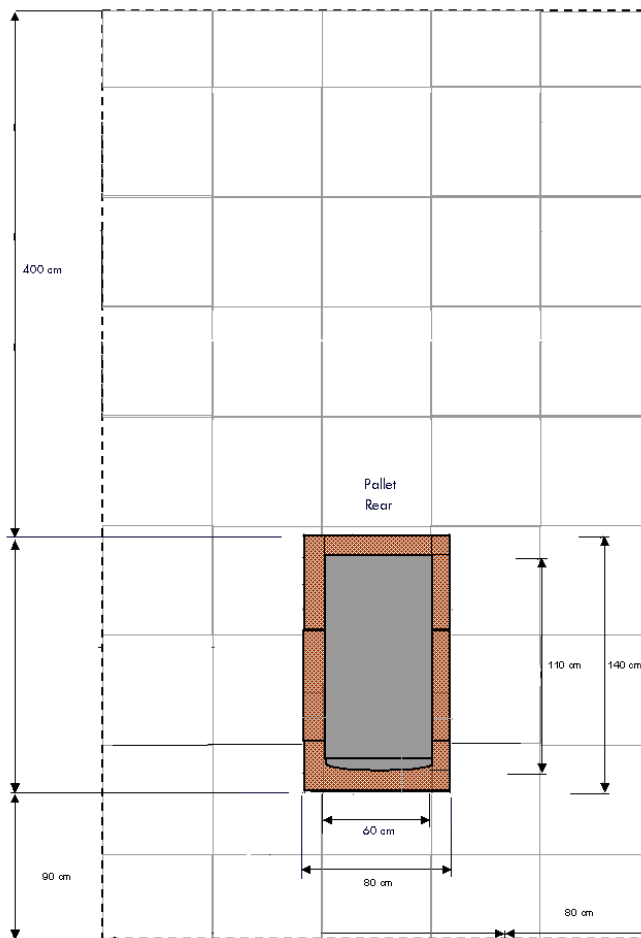

Figure 12. Required unpacking area

2.4.2. Unpacking the R@ck'n Roll Cabinet

Tools required

- Standard pallet truck
- Cutter

Surface

- 3m x 3m = 9 m²
- Flat and horizontal

1. Check the indicators on the external shockwatch and tiltwatch labels.
2. Remove the stretch film and elastics with the cutter, taking care not to damage the cabinet.
3. Remove the internal protection cover.
4. Set packing items aside.

2.4.3. Depalletizing the R@ck'n Roll Cabinet

Tools required

- Cross-threaded screwdriver
- Combination wrench: 10

Surface

- 4m x 3m = 12 m²
- Flat and horizontal



DANGER

Three people at least are required to depalletize the cabinet

1. Remove the rear door by lifting it off its hinges and set aside.
2. Unscrew the M6 screws, bolts and wood screws to free the 2 depalletizing rails located on either side of the pallet.
3. Remove the 2 depalletizing rails and align them with the rear pallet rails.
4. Insert the 2 depalletizing rail snugs in the pallet holes and secure into place with the wood screws.
5. Check that the cabinet feet are in the highest position and that the cabinet wheels are correctly aligned on the depalletizing rails.
6. Carefully roll the cabinet along the depalletizing rails and off the pallet:
2 persons at least must support the cabinet on the rail side
1 person at least must guide the cabinet on the opposite side.
7. Move the cabinet to the required location and lower the feet to secure it into place.
8. Replace the rear door on its hinges.

2.5. Inspecting the Cabinet

Once the cabinet has been unpacked, a preliminary visual inspection must be performed before it is unloaded from the shipping pallet.



CAUTION

Pre-equipped cabinets:

If the inspection indicates an unacceptable safety condition, the condition must be corrected before powering up the server and/or devices inside the cabinet.

1. Check that the delivery is compliant with the Purchase Order.
2. Check that the boxes labeled **Open Me First** and **Unpacking Box** contain the stabilizer and skate-board assemblies.
3. Check covers and doors for sharp edges, damage or alterations.
4. Check the correct fit of covers and doors.
5. Open the front and rear doors.

Note Unlock the front door with the key, pull the handle forwards and upwards to disengage the lock.

6. Check for internal damage, alterations and obvious safety hazards such as broken wires, sharp edges, or broken insulation.
7. Check internal cables for damage.
8. Check for dirt, water, and any other form of contamination inside the cabinet.
9. Check the voltage label on the back of the cabinet to ensure that it matches the voltage at the power outlet.
10. Check external power cables for damage.
11. Check correct closure of front and rear doors. Unlock the front door with the key, pull the handle forwards and upwards to disengage the lock. Unlock the front door with the key, pull the handle forwards and upwards to disengage the lock.

2.6. Moving the Cabinet

The cabinet is equipped with four swivel castors so that it can be easily rolled to the location indicated on the Customer's floor plan.



CAUTION

If the cabinet is pre-equipped with servers and/or devices, two people are required to roll it to the required location.

1. Check that the two front and four feet are raised and allow the cabinet to move freely.
2. Carefully guide the cabinet to its location.
3. Check required service clearance at the rear, front and sides of the cabinet.
4. Take care to leave sufficient access to raised floor cable cut-outs.

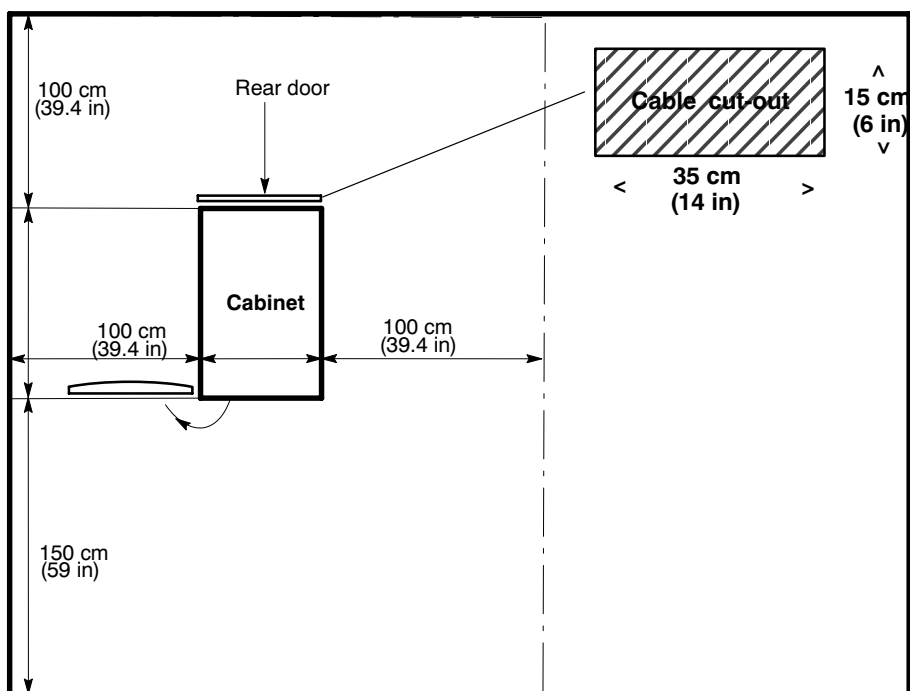

Figure 13. Cabinet service clearance

2.7. Securing the Cabinet

Once the cabinet has been correctly located, it must be secured into place by lowering feet and installing the stabilizer (optional).



DANGER

When equipped with servers and/or devices, the cabinet may be extremely heavy. It is mandatory for cabinet jacking screws to be locked safely into place and for the stabilizer to be installed before use or maintenance. Incorrect installation may result in serious personal injury or damage to components.

2.7.1. Lowering Feet

The jacking screws prevent the cabinet from rolling.

Tools Required

- None
1. Manually lower and lock the two front and four rear jacking screws into place.

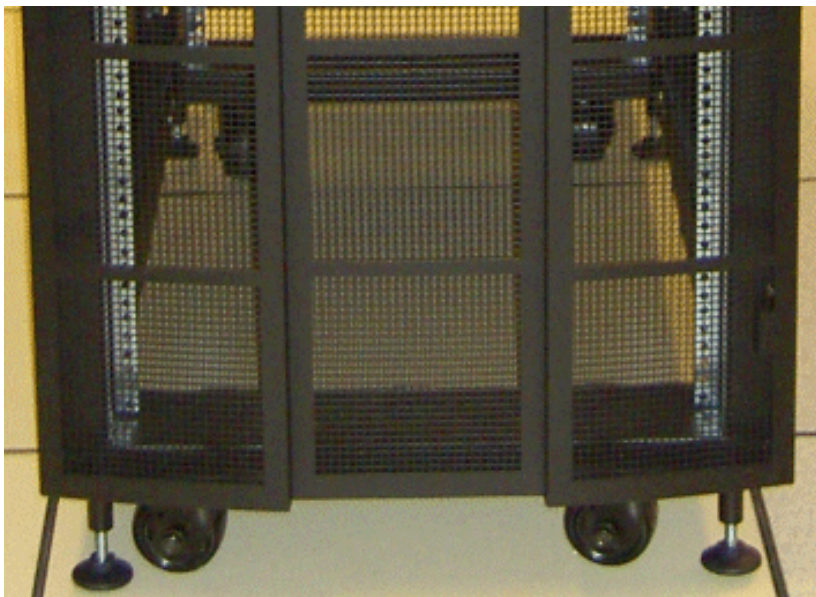

2. Lowering feet
3. Check cabinet stability.

2.8. Removing / Installing / Turning the Doors and Side Panels

For easy access, the front and rear doors and side panels can be removed when you install or remove servers and/or devices in the cabinet.

2.8.1. Removing the Door

Tools Required

- Door key
1. Unlock the door and pull the handle forwards and upwards to disengage the lock.
 2. Open the door. The door is secured to the hinges with two door pins.
 3. Remove the bottom door pin by pulling upwards and out of the hinge.
 4. Remove the top door pin by pulling upwards and out of the hinge.
 5. Firmly grip either side of the door and lift away to remove from the hinges.
 6. Store the door and door pins in a safe place.

2.8.2. Installing the Door

Tools Required

- Door key
1. Firmly grip either side of the front door and place at a right angle with the cabinet.
 2. Line the door up with the hinges.
 3. Carefully push the door onto the hinges.
 4. Insert the top door pin by pushing downwards into the hinge
 5. Insert the bottom door pin by pushing downwards into the hinge.
 6. Close the door and engage the lock by lowering the handle and pushing it back into the recess.
 7. Lock the door with the key.

2.8.3. Turning the Front and/or Rear Door

You can turn the front and/or rear door to change the opening direction to suit site configuration requirements.

Tools Required

- Screwdriver
1. Remove the door. See Removing / Installing / Turning the Doors and Side Panels , on page 2-13.
 2. Turn the door up the other way.
 3. Unscrew the locking bracket on the cabinet flange and screw back onto the opposite cabinet flange.

Note Rear door only:
Use the locking bracket provided in the box labeled *Open Me First*.

4. Unscrew the lock on the door, turn up the other way, and screw back into place.
5. Unscrew the locking mechanism, turn up the other way, and screw back into place on the other side of the lock.
6. Unscrew the logo, turn up the other way and screw back into place.
7. Refit the door. See Removing / Installing / Turning the Doors and Side Panels, on page 2-13.

2.8.4. Removing a Side Panel

Tools Required

- Screwdriver
1. With the screwdriver, turn the two locks at the top of the side panel clockwise, taking care to hold the side panel in place.
 2. Firmly grip either side of the side panel and lift carefully off the three lugs at the base of the cabinet.
 3. Store the side panel in a safe place.

2.8.5. Installing a Side Panel

Tools Required

- Screwdriver
1. Firmly grip either side of the side panel and lift carefully onto the three lugs at the base of the cabinet.
 2. With the screwdriver, turn the two locks at the top of the side panel anti-clockwise, taking care to hold the side panel in place.
 3. Check that the side panel is secure.

2.9. Installing Servers and/or Devices



Important

You are requested to read the Safety Notices set out in the preface of this document before installing or servicing cabinets.

The documentation delivered with rack-mountable servers and devices may contain important safety information. You are requested to carefully read the documentation delivered with servers and devices before installing them in the cabinet.



DANGER

- Feet must always be lowered.
- The stabilizer must always be installed when heavy equipment is loaded at the top of the cabinet.
- Servers and devices must always be fitted in the cabinet from the bottom upwards.
- Servers and devices must be fitted in the cabinet so that the air-flow is from front to back: all fans blowing towards the rear of the cabinet.
- The weight of servers and devices fitted in the cabinet must not exceed 20 kg (44 lbs) per U.
- Never slide more than one server or device out of the rack at a time.
- Thermal dissipation must not exceed 40 KW.
- Firmly secure servers and devices to the mounting flanges at the front and rear of the cabinet.
- Always use the mounting fixtures supplied with the servers and/or devices.

2.9.1. Checking Server / Device Compatibility

Before installing a server or device in the cabinet, you are advised to check and compare the internal dimensions of the cabinet with the external dimensions of the server / device and accessories (rail assembly, front bezel, handles, ...).

The following figure shows a top view of the cabinet and illustrates the dimensions to be taken into account before installing a server or device in the cabinet.

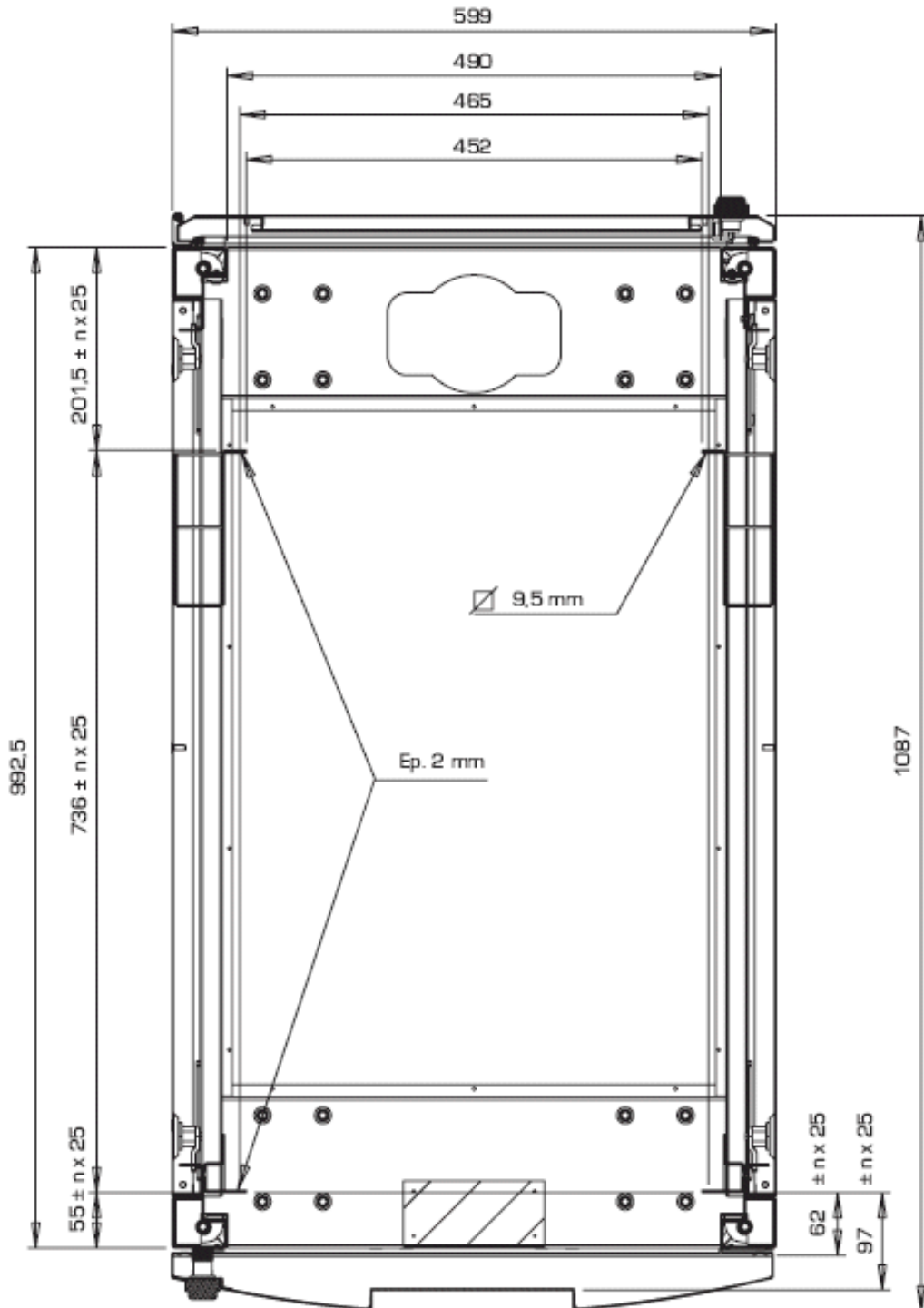

Figure 14. Internal cabinet dimensions

2.10. Fitting Equipment Trays

An equipment tray may be required to fit peripheral devices in cabinets.

Three equipment trays are available:

- Short Equipment Tray
- Medium Equipment Tray
- Long Equipment Tray



Important

The documentation delivered with non-rackable peripheral devices may contain important safety information. You are requested to carefully read the documentation delivered with these devices before installing them on the equipment tray.

Mounting Flange Hole Size and Placement

Note 1 U = 44.45 mm (1.75 in)

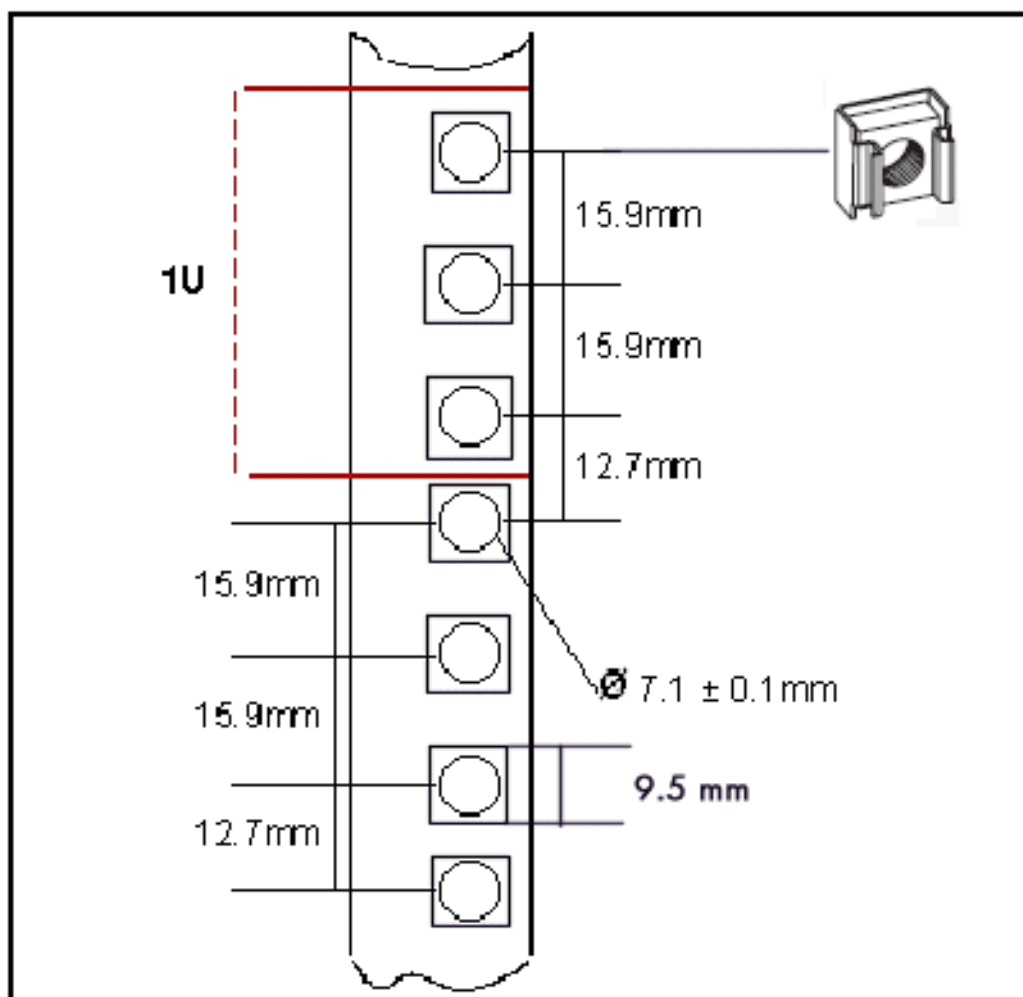

Figure 15. Mounting flange hole size and placement

2.11. Installing a PDU

Each PDU is delivered with mounting brackets for vertical and/or horizontal installation in the cabinet.

Note **Vertical Installation**
Up to six PDUs can be installed vertically in the cabinet flange space (3 right and 3 left).



Important

Before choosing a location for a PDU, check power cable length from the servers and devices you want to connect to the PDU.
Before proceeding to install the PDU, check that the circuit breaker switch is OFF.

Tools Required

- Hex wrench
- PDU fixtures

Vertical Installation

1. Select the required location in the cabinet.
2. Install one cage nut (A) over the fixture holes at the top and bottom of the cabinet cut-out.



Figure 16. Installing a PDU vertically

3. Align the PDU with the cut-out in the cabinet flange and push firmly into place.
4. Insert the bolt and washer assemblies in the central PDU fixture holes (B) and tighten with the hex wrench.

Horizontal Installation

1. Select the required location in the cabinet.
2. Install 2 cage nuts (A) over the required rack fixture holes on each side of the cabinet.

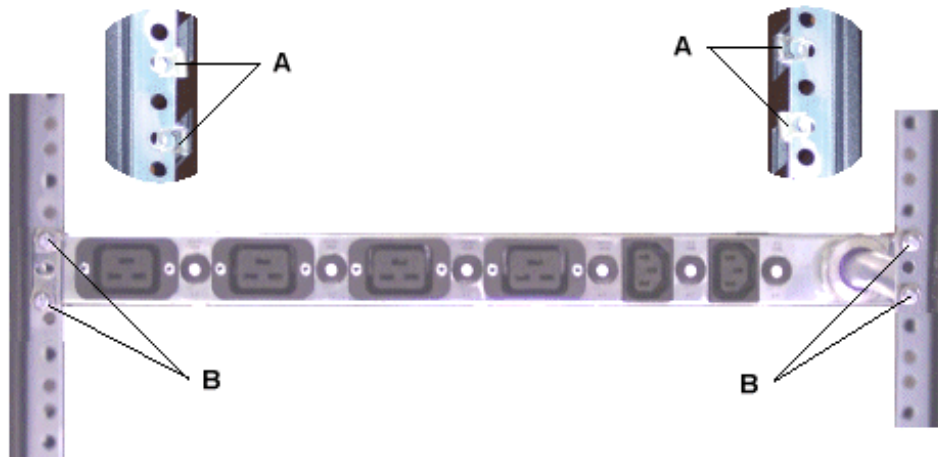

Figure 17. Installing a PDU horizontally

3. Align the PDU fixture holes with the rack fixture holes on the left and right sides of the cabinet.
4. Insert the bolt and washer assemblies in the top and bottom PDU fixture holes (B) and tighten with the hex wrench.

Chapter 3. Managing Power and Data Cables

This chapter gives general recommendations for routing and connecting power and data cables inside the cabinet. It includes the following topics:

- Routing Data Cables, on page 3-1
- Routing and Connecting Power Cables, on page 3-1
- Connecting the PDU to the Site Power Supply, on page 3-2



Important

Please refer to the documentation delivered with your server and/or device for detailed cable management information.

3.1. Routing Data Cables

Please refer to the documentation delivered with your server and/or device for detailed cable management information.



Important

GENERAL RECOMMENDATIONS

- Label all cables for easy identification.
 - Secure cables with appropriate fixtures.
 - Ensure that cables are clear of doors and panels.
 - Take care not to route cables in front of other servers or devices.
 - When servers or devices are installed on slide rails:
Leave extra cable lengths for full mobility.
Route cables along cable arms and secure with appropriate fixtures.
 - Check that the PDU is compliant with server and/or device power requirements.
-

3.1.1. Routing Inter-Cabinet Data Cables



DANGER

Power cables must NEVER be routed between cabinets.



Important

Route inter-cabinet data cables through the cable openings at the rear of the cabinets.

3.2. Routing and Connecting Power Cables

Please refer to the documentation delivered with your server and/or device for detailed cable management information.

3.3. Connecting a PDU to the Site Power Supply

As required in the *Site Preparation Guide*, the Customer has provided the required power supply cables to the cable cut-outs at the base of the cabinet.

The Customer is responsible for ensuring that the electrical network is compliant with the standards set out in the *Site Preparation Guide*.

PDU power cables are equipped with ready-mounted IEC60309 plugs. The Customer is responsible for supplying the appropriate IEC60309 sockets for connection to the site power supply. The following figure shows the provided plug and the appropriate socket.



Figure 18. Power plug and socket

3.3.1. Safety Recommendations



CAUTION

Only duly certified electricians may connect the PDU to the power supply, under the Customer's responsibility.



CAUTION

The PDU is equipped with three-wire power cables for user safety. Use these power cables with properly grounded electrical outlets to avoid electrical shock.



DANGER

An electrical outlet that is not correctly wired could place hazardous voltage on metal parts. It is the Customer's responsibility to ensure that the outlet is correctly wired and grounded to prevent an electrical shock.



DANGER

Use one hand, when possible, to connect or disconnect signal cables to prevent a possible shock from touching two surfaces with different electrical potentials. Due to energy hazard, remove all jewelry before servicing. Check that the dedicated power supply circuit breakers are OFF.

3.3.2. Mounting the PDU Power Cable Socket

1. Check that the power supply cable is not live with the multimeter.
2. Carefully guide the PDU power supply cable through the cable inlet at the base of the cabinet.
3. Check that the power supply cable is long enough for connection to the PDU.

4. Unscrew the base of the socket (A), insert the cable through the socket base (B), and wire to the socket head, as shown below. *Power supply cabling*



Figure 19. PDU power socket

5. Screw the socket base back to the socket head (C).
 6. Check for ≤ 0.1 ohm resistance between the grounding pin on the power cable plug and the metal frame with the multimeter.
 7. Connect the power supply cable socket to the PDU power cable plug.
 8. Use appropriate fasteners to secure the cable into place along the cabinet frame.
- The PDU can now be connected to the site power supply.

Appendix A. Specifications

This appendix gives detailed specifications for all cabinet and PDU models.

- Rack'n Roll Cabinet Specifications, on page A-2
- Rack-to-Build Cabinet Specifications, on page A-2
- PDU Common Electrical Specifications, on page A-3
- PDU 63A, 2xC13 - 4xC19, EU Specifications, on page A-4
- PDU 32A, 4xC13 - 2xC19, EU Specifications, on page A-4
- PDU 32A, 7xC13 EU Specifications, on page A-5
- PDU 32A, 12xC13 EU Specifications, on page A-5
- PDU 24A, 4xC13 - 2xC19, US, on page A-6

A.1. R@ck'n Roll Cabinet Specifications

Dimensions / Weight			
Unpacked		Packed	
Height:	202 cm (80.0 in)	Height:	212 cm (83.5 in)
Width:	60.0 cm (23.6 in)	Width:	80.0 cm (31.5 in)
Depth:	111.5 cm (43.9 in)	Depth:	122.0 cm (55.1 in)
Weight (empty):	135 kg (298 lb)	Weight (empty):	165 kg (364 lb)
Weight (full max.):	935 kg (2062 lb)	Weight (full max.):	965 kg (2128 lb)
Maximum load:	800 kg (1764 lb)		
Service Clearance			
Front		150 cm	
Rear		100 cm	
Side (left and right)		100 cm	
Shipping Limits (NF ISO 2233)			
Temperature:	20°C		
Relative Humidity:	65%		

Table 1. R@ck'n Roll Cabinet Specifications

A.2. R@ck-to-Build Cabinet Specifications

Dimensions / Weight			
Unpacked		Packed	
Height:	202 cm (80.0 in)	Height:	212 cm (83.5 in)
Width:	60.0 cm (23.6 in)	Width:	80.0 cm (31.5 in)
Depth:	111.5 cm (43.9 in)	Depth:	122.0 cm (55.1 in)
Weight (empty):	135 kg (298 lb)	Weight (empty):	165 kg (364 lb)
Weight (full max.):	935 kg (2062 lb)	Weight (full max.):	965 kg (2128 lb)
Maximum load:	800 kg (1764 lb)		
Service Clearance			
Front		150 cm	
Rear		100 cm	
Side (left and right)		100 cm	
Shipping Limits (NF ISO 2233)			
Temperature:	20°C		
Relative Humidity:	65%		

Table 2. R@ck-to-Build Cabinet Specifications

A.3. PDU Common Electrical Specifications

Notes It is mandatory for power lines and terminal boxes to be located within the immediate vicinity of the system and to be easily accessible.

Each power line must be connected to a separate, independent electrical panel and bipolar circuit breaker.

France:

Power sockets and plugs must be compliant with

Decree 88-1056 Article 20-IV, dated 14th November 1988.

Europe	
Nominal voltage	230 VAC (Phase / Neutral)
Voltage range	207 - 244 VAC
Frequency	50 Hz \pm 1%
North America	
Nominal voltage	208 VAC (Phase / Neutral)
Voltage range	200 - 240 VAC
Frequency	60 Hz \pm 0.3%
Japan	
Nominal voltage	200 VAC (Phase / Neutral)
Voltage range	188 - 212 VAC
Frequency	60 Hz \pm 0.2%
Brazil	
Nominal voltage	220 VAC (Phase / Neutral)
Voltage range	212 - 231 VAC
Frequency	60 Hz \pm 2%

Table 3. PDU common specifications

A.4. PDU 63A, 2xC13 - 4xC19, EU Specifications

Dimensions / Weight	
Height	4.1 cm (1.6 in)
Width	48.3 cm (19 in)
Depth	12 cm (4.7 in)
Weight	2 kg (4.4 lb)
Outlets	
14.5A (C19)	4
9A (C13)	2
Power Cables	
AC (63A)	1 per PDU
Mains cable type	3 x AWG06
Mains plug type	IEC60309-63A
Mains socket type	IEC60309-63A
Breaker Protection	
Maximum current	63A
Maximum voltage	250 VAC

Table 4. PDU 63A, 2xC13 - 4xC19, EU specifications

A.5. PDU 32A, 4xC13 - 2xC19, EU Specifications

Dimensions / Weight	
Height	4.1 cm (1.6 in)
Width	48.3 cm (19 in)
Depth	12 cm (4.7 in)
Weight	2 kg (4.4 lb)
Outlets	
14.5A (C19)	2
9A (C13)	4
Power Cables	
AC (32A)	1 per PDU
Mains cable type	3 x AWG10
Mains plug type	IEC60309-32A
Mains socket type	IEC60309-32A
Breaker Protection	
Maximum current	32A
Maximum voltage	250 VAC

Table 5. PDU 32A, 4xC13 - 2xC19, EU specifications

A.6. PDU 32A, 7xC13 EU Specifications

Dimensions / Weight	
Height	4.35 cm (1.6 in)
Width	48.3 cm (19 in)
Depth	12 cm (4.7 in)
Weight	2 kg (4.4 lb)
Outlets	
14.5A (C19)	0
9A (C13)	7
Power Cables	
AC (32A)	1 per PDU
Mains cable type	3 x AWG10
Mains plug type	IEC60309-32A
Mains socket type	IEC60309-32A
Breaker Protection	
Maximum current	32A
Maximum voltage	250 VAC

Table 6. PDU 32A, 7xC13 EU specifications

A.7. PDU 32A, 12xC13 EU Specifications

Dimensions / Weight	
Height	4.1 cm (1.7 in)
Width	48.3 cm (19 in)
Depth	12 cm (4.7 in)
Weight	2 kg (4.4 lb)
Outlets	
14.5A (C19)	0
9A (C13)	12
Power Cables	
AC (24A)	1 per PDU
Mains cable type	3 x AWG10
Mains plug type	IEC60309-32A
Mains socket type	IEC60309-32A
Breaker Protection	
Maximum current	32A
Maximum voltage	250 VAC

Table 7. PDU 32A, 12xC13 EU specifications

A.8. PDU 24A, 4xC13 - 2xC19, US Specifications

Dimensions / Weight	
Height	4.1 cm (1.7 in)
Width	48.3 cm (19 in)
Depth	12 cm (4.7 in)
Weight	2 kg (4.4 lb)
Outlets	
16A (C19)	2
8A (C13)	4
Power Cables	
AC (24A)	1 per PDU
Mains cable type	3 x AWG10
Mains plug type	IEC60309-32A
Mains socket type	IEC60309-32A
Breaker Protection	
Maximum current	24A
Maximum voltage	125VAC

Table 8. PDU 24A, 4xC13 - 2xC19, US specifications

Glossary

A

AC: Alternating Current generated by the power supply. See DC.

ACPI: Advanced Configuration and Power Interface. An industry specification for the efficient handling of power consumption in desktop and mobile computers. ACPI specifies how a computer's BIOS, operating system, and peripheral devices communicate with each other about power usage.

Address: A label, name or number that identifies a location in a computer memory.

AMI: American Megatrends Incorporated.

ANSI: American National Standards Institute.

API: Application Program Interface. The specific method prescribed by a computer operating system or by an application program by which a programmer writing an application program can make requests of the operating system or another application.

Archive: (Archive file). A file that is a copy of a history file. When a history file is archived, all messages are removed from the history file.

ASCII: American National Standard Code for Information Interchange. A standard number assigned to each of the alphanumeric characters and keyboard control code keys to enable the transfer of information between different types of computers and peripherals.

B

Backup: A copy of data for safe-keeping. The data is copied from computer memory or disk to a floppy disk, magnetic tape or other media.

Backup battery: The battery in a computer that maintains real-time clock and configuration data when power is removed.

Baud rate: The speed at which data is transmitted during serial communication.

BERR: Bus Error signal pin used to signal a global machine check abort condition.

BNIT: Bus Initialization signal pin used to signal a global fatal machine check condition.

BIOS: Basic Input / Output System. A program stored in flash EPROM or ROM that controls the system startup process.

BIST: Built-In Self-Test. See POST.

Bit: Derived from Binary digiT. A bit is the smallest unit of information a computer handles.

BTU: British Thermal Unit.

Byte: A group of eight binary digits (bit) long that represents a letter, number, or typographic symbol.

C

Cache Memory: A very fast, limited portion of RAM set aside for temporary storage of data for direct access by the microprocessor.

CD-ROM: Compact DisK Read-Only Memory. High-capacity read-only memory in the form of an optically readable compact disk.

Cell: The smallest set of hardware components allocated to a single OS. A cell is functionally defined by:

- the number of available processors
- memory capacity
- I/O channel capacity.

CellBlock: A group of interconnected cells within a single domain. See Central Subsystem.

Central Subsystem: A group of interconnected cells gathered within a single domain. See CellBlock.

Chained DIBs: Two DIBs can be inter-connected to house 4 SCSI RAID disks, 1 DVD-ROM drive, 1 USB port. See DIB and IPD.

Chip: Synonym for integrated circuit. See IC.

Clipping: A PAM Event filter criterion. Clipping is defined on a Count / Time basis aimed at routing a pre-defined number of messages only. Identical messages are counted and when the number of messages indicated in the Count field is reached within the period of time indicated in the Time field, no other messages will be selected for routing.

CMC: Corrected Memory Check condition is signaled when a hardware corrects a machine check error or when a MCA condition is corrected by firmware.

CMCI: Corrected Memory Check Interrupt.

CMCV: Corrected Memory Check Vector.

CMOS: Complementary Metal Oxide Semiconductor. A type of low-power integrated circuits. System startup parameters are stored in CMOS memory. They can be changed via the system setup utility.

COM: Component Object Model. Microsoft technology for component based application development under Windows.

COM +: Component Object Model +. Microsoft technology for component based application development under Windows. The external part of the PAM software package is a COM+ application.

COM1 or COM2: The name assigned to a serial port to set or change its address. See Serial Port.

Command: An instruction that directs the computer to perform a specific operation.

Configuration: The way in which a computer is set up to operate. Configurable options include CPU speed, serial port designation, memory allocation, ...

Configuration Tasks: A PAM feature used to configure and customize the server.

Control Pane: One of the three areas of the PAM web page. When an item is selected in the PAM Tree pane, details and related commands are displayed in the Control pane. See PAM Tree pane and Status pane.

Core Unit: A main CSS module unit interconnecting the MIO, MQB, MSX and MFL boards. See MIO, MQB, MSX, MFL.

COS: Cluster Operating System.

CPE: Corrected Platform Error.

CPEI: Corrected Platform Error Interrupt.

CPU: Central Processing Unit. See Microprocessor and Socket.

CSE: Customer Service Engineer.

CSS: Central Sub-System. See CellBlock.

CSS Module: A MidPlane with all its connected components (QBBs, IO boards, PMB) and utility devices. See Module.

D

D2D: DC to DC converter.

DC: Direct Current generated by the power supply. See AC.

Default Setting: The factory setting your server uses unless instructed otherwise.

Density: The capacity of information (bytes) that can be packed into a storage device.

Device Driver: A software program used by a computer to recognize and operate hardware.

DIB: Device Interface Board. The DIB provides the necessary electronics for the Internal Peripheral Drawer. See IPD and Chained DIBs.

DIG64: Developer Interface Guide for IA64.

DIM Code: Device Initialization Manager. Initializes different BUSES during the BIOS POST.

DIMM: Dual In-line Memory Module - the smallest system memory component.

Disk Drive: A device that stores data on a hard or floppy disk. A floppy disk drive requires a floppy disk to be inserted. A hard disk drive has a permanently encased hard disk.

DMA: Direct Memory Access. Allows data to be sent directly from a component (e.g. disk drive) to the memory on the motherboard). The microprocessor does not take part in data transfer enhanced system performance.

DMI: Desktop Management Interface. An industry framework for managing and keeping track of hardware and software components in a system of personal computers from a central location.

DNS: Domain Name Server. A server that retains the addresses and routing information for TCP/IP LAN users.

Domain: is the coherent set of resources allocated to run a customer activity, i.e. the association -at boot time- of a Partition, an OS instance (including applications) and associated LUNs and an execution context including execution modes and persistent information (e.g. time, date of the OS instance). Domain definitions and initializations are performed via PAM. A Domain can be modified to run the same OS instance on a different Partition. When a Domain is running, its resources are neither visible nor accessible to other running Domains.

Domain Identity: a PAM Domain management logical resource. This resource contains context information related to the Customer activity running in a domain. The most visible attribute of this resource is the name that the Customer gives to the activity. For each domain created, the Domain management feature allows the operator to define a new activity or choose an activity from the list of existing activities. See Domain.

Domain Manager: A PAM feature used to power on / off and manage server domains. See Domain.

DPS: Distributed Power Supply.

DRAM: Dynamic Random Access Memory is the most common type of random access memory (RAM).

E

ECC: Error Correcting Code.

EEPROM: Electrically Erasable Programmable Read-Only Memory. A type of memory device that stores password and configuration data. See also EPROM.

EFI: Extensible Firmware Interface.

EFIMTA: EFI Modular Test Architecture.

EFI Shell: The EFI (Extensible Firmware Interface) Shell is a simple, interactive user interface that allows EFI device drivers to be loaded, EFI applications to be launched, and operating systems to be booted. In addition, the EFI Shell provides a set of basic commands used to manage files and the system environment variables. See Shell.

EMI: Electro-Magnetic Interference.

EPROM: Erasable Programmable Read-Only Memory. A type of memory device that is used to store the system BIOS code. This code is not lost when the computer is powered off.

ERC: Error and Reset Controller. This controller allows PAM software to control error detection and reset propagation within each pre-defined CSS partition. The ERC is initialized by PAM software to ensure a partition-contained distribution of the reset, error, interrupt and event signals; and to contribute to error signaling and localization at platform level.

ERP: Error Recovery Procedure.

ESD: ElectroStatic Discharge. An undesirable discharge of static electricity that can damage equipment and degrade electrical circuitry.

Event: The generation of a message (event message) by a software component and that is directed to the Event Manager.

Event address: Defines the destination for a message sent over a specified event channel. An address is one of: the name of a history file (for the HISTORY channel), an e-mail address (for the EMAIL channel), the name of a user group (for the WEB channel), the SNMP Manager IP address (for the SNMP channel).

Event channel: Defines how the Event Manager sends an event message. An event channel is one of: HISTORY (the message is logged in a history file), EMAIL (the message is sent to an e-mail address), WEB (the message is stored for analysis from the PAM web user interface), SNMP (the message is sent as an SNMP trap to the selected SNMP application).

Event filter: A list of selected messages among all possible event messages. If an event message is not included in the filter, the Event Manager discards the message.

Event Manager: A PAM feature used to forward event messages over a configured event channel. See Event.

Event message: A message sent by a software component to the Event Manager for routing to a destination that is configured by an administrator.

Event subscription: An object that defines the event channel, address, and filter for sending an event message. If no such object is defined, the event message is discarded.

Exclusion: Logical removal of a redundant faulty hardware element until it has been repaired or replaced. The hardware element remains physically present in the configuration, but is no longer detected by PAM software and can no longer be used by a domain.

External Disk Subsystem: Disk subsystem housed inside the NovaScale cabinet.

F

Fail-over: Failover is a backup operational mode in which the functions of a system component (such as a processor, server, network, or database, for example) are assumed by secondary system components when the primary component becomes unavailable through either failure or scheduled down time.

FAME: Flexible Architecture for Multiple Environments.

FAST WIDE: A standard 16-bit SCSI interface providing synchronous data transfers of up to 10 MHz, with a transfer speed of 20M bytes per second.

FC: Fibre Channel.

FCAL: Fibre Channel Arbitrated Loop.

FCA: Fibre Channel Adapter.

FCBQ: Fan Control Board for QBB.

FCBS: Fan Control Board for SPS.

FDA: Fibre Disk Array.

FDD: Floppy Disk Drive.

Flash EPROM: Flash Erasable Programmable Read-Only Memory. A type of memory device that is used to store the the system firmware code. This code can be replaced by an updated code from a floppy disk, but is not lost when the computer is powered off.

Firewall: A set of related programs, located at a network gateway server, that protects the resources of a private network from users from other networks.

Firmware: an ordered set of instructions and data stored to be functionally independent of main storage.

Format: The process used to organize a hard or floppy disk into sectors so that it can accept data. Formatting destroys all previous data on the disk.

FPB: FAME Power Board (FAME: Flexible Architecture for Multiple Environments).

FPGA: Field Programmable Gate Array. A gate array that can be reprogrammed at run time.

FRB: Fault Resilient Boot. A server management feature. FRB attempts to boot a system using the alternate processor or DIMM.

FRU: Field Replaceable Unit. A component that is replaced or added by Customer Service Engineers as a single entity.

FSS: FAME Scalability Switch. Each CSS Module is equipped with 2 Scalability Port Switches providing high speed bi-directional links between server components. See SPS.

FTP: File Transfer Protocol. A standard Internet protocol: the simplest way of exchanging files between computers on the Internet. FTP is an application protocol that uses Internet TCP/IP protocols. FTP is commonly used to transfer Web page files from their creator to the computer that acts as their server for everyone on the Internet. It is also commonly used to download programs and other files from other servers.

FWH: FirmWare Hub.

HPB: Hot Plug Board. This board provides an interlock switch on each IO Box PCI slot for hot-swapping PCI boards. See P-HPB.

HPC: High Performance Computing.

Hot plugging: The operation of adding a component without interrupting system activity.

Hot swapping: The operation of removing and replacing a faulty component without interrupting system activity.

HTTP: HyperText Transfer Protocol. In the World Wide Web, a protocol that facilitates the transfer of hypertext-based files between local and remote systems.

HW Identifier: Number (0 - F) used to identify Cellblock components. This number is identical to PMB code-wheel position.

G

GB: GigaByte: 1,073,741,824 bytes. See Byte.

Global MCA: Machine Check Abort is visible to all processors, in a multiprocessor system and will force all of them to enter machine check abort.

GUI: Graphical User Interface.

GTS: Global Telecontrol Server.

H

HA: High Availability. Refers to a system or component that is continuously operational for a desirably long length of time.

HAL: Hardware Abstraction Layer.

HA CMP: High Availability Clustered MultiProcessing.

Hard Disk Drive: HDD. See Disk Drive.

Hardware: The physical parts of a system, including the keyboard, monitor, disk drives, cables and circuit cards.

Hardware Monitor: A PAM feature used to supervise server operation.

HBA: Host Bus Adapter.

HDD: Hard Disk Drive. See Disk Drive.

History File: A file in which the History Manager logs informative messages or error messages relating to system activity. Messages are sent from source components to target components.

History Manager: The component running on the PAP Windows operating system that logs messages to history files.

HMMIO Space: High Memory IO Space.

I

I2C: Intra Integrated Circuit. The I2C (Inter-IC) bus is a bi-directional two-wire serial bus that provides a communication link between integrated circuits (ICs). The I2C bus supports 7-bit and 10-bit address space devices and devices that operate under different voltages.

IA64: is a 64-bit Intel processor Architecture based on Explicitly Parallel Instruction Computing (EPIC). The Itanium processor is the first in the Intel line of IA-64 processors.

IB: Infini Band.

IC: Integrated Circuit. An electronic device that contains miniaturized circuitry. See Chip.

ICH2: I/O Controller Hub 2, component that contains the fundamental I/O interfaces required by the system. Flash memory, Keyboard, USB and IDE device interface.

ICH4: I/O Controller Hub 4.

ICMB: Intelligent Chassis Management Bus.

ID: A number which uniquely identifies a device on a bus.

IDE: Integrated Drive Electronics. A type of hard disk drive with the control circuitry located inside the disk drive rather than on a drive controller card.

Identity: See Domain Identity.

IIS: Internet Information Server. A group of Internet servers (including a Web or HTTP server and a FTP server) with additional capabilities for Microsoft® Windows® NT and Microsoft Windows (and later) operating systems.

I/O: Input /Output. Describes any operation, program, or device that transfers data to or from a computer.

Interface: A connection between a computer and a peripheral device enabling the exchange of data. See Parallel Port and Serial Port.

Internal Disk Subsystem: Disk subsystem housed inside the NovaScale Internal Peripheral Drawer (IPD).

IOB: Input / Output Board. The IOB connects up to 11 PCI-X boards.

IOC: Input / Output Board Compact. The IOC connects up to 6 PCI-X boards.

IOL: I/O Board Legacy. The IOL provides:

- I/O controller Hub
- USB ports
- 10/100/1000 Ethernet controller
- Video controller
- Serial / debug port

IOR: I/O Board Riser. The IOR provides:

- I/O controller Hub
- USB ports
- 10/100/1000 Ethernet controller
- Video controller
- Serial / debug port

IP: Internet Protocol. The protocol by which data is sent from one computer to another via the Internet. Each computer (known as a host) on the Internet has at least one IP address that uniquely identifies it from all other computers on the Internet.

IPD: Internal Peripheral Drawer. The IPD houses legacy peripherals (DVD-Rom drive, USB port) and SCSI system disks. See DIB and Chained DIBs.

IPF: Itanium Processor Family.

IPL: Initial Program Load. It defines the firmware functional phases during the system initialization.

IPMB: Intelligent Platform Management Bus.

IPMI: Intelligent Platform Management Interface.

ISA: Industry Standard Architecture. An industry standard for computers and circuit cards that transfer 16 bits of data at a time.

J

Jumper: A small electrical connector used for configuration on computer hardware.

K

KVM: Keyboard Video Monitor.

KVM switch: the Keyboard Video Monitor switch allows the use of a single keyboard, monitor and mouse for more than one module.

L

LAN: Local Area Network. A group of computers linked together within a limited area to exchange data.

LD: Logical Disk. A Storeway FDA 1x00/2x00 logical disk (or LUN) is visible to the OS as a Disk. See LUN and PD (Physical Disk).

LED: Light Emitting Diode. A small electronic device that glows when current flows through it.

Legacy Application: An application in which a company or organization has already invested considerable time and money. Typically, legacy applications are database management systems (DBMSs) running on mainframes or minicomputers.

Licensing Number: When you install an application protected by a system serial number, you are requested to supply this serial number. For optimum flexibility, PAM software allows you to replace the physical serial number by a logical licensing number so that you can run the application on any physical partition and, in the case of extended systems, on any of the Central Subsystems within the extended configuration.

LID: Local Interrupt Identifier (CPU).

Local Disk Subsystem: Disk subsystem housed inside the NovaScale cabinet and not connected to a SAN.

Local MCA: Machine Check Abort is detected and handled by a single processor and is invisible to the other processor.

Locking: Means of functionally limiting access to certain hardware elements. Locked hardware elements can no longer be accessed by the current domain, but are still physically available for use by other domains. Previously locked elements can be unlocked so that they can be accessed by the domain.

LPT1 or LPT2: The name assigned to a parallel port to specify its address. See Parallel Port.

LS240: Laser Servo super diskette holding up to 240 Mb.

LUN: Logical Unit Number. Term used to designate Logical Storage Units (logical disks) defined through the configuration of physical disks stored in a mass storage cabinet.

LVDS: Low Voltage Differential SCSI.

M

MAESTRO: Machine Administration Embedded Software Real Time Oriented. Part of the PAM software package embedded on the PMB board.

MCA: Machine Check Abort.
See also Local MCA and Global MCA.

Memory: Computer circuitry that stores data and programs. See RAM and ROM.

Memory bank: The minimum quantity of memory used by the system. It physically consists of four memory DIMMs.

MFL: Midplane Fan & Logistics board. The MFL houses the Fan Boxes and is connected to the MIO and MQB. See MIO, MQB.

Microprocessor: An integrated circuit that processes data and controls basic computer functions.

Midplane: Mid-Plane. All system hardware components are connected to the Midplane.

MIMD: Multiple Instruction Multiple Data

MIO: Midplane Input / Output board. The MIO connects one or two IOC boards and the PMB. See Core Unit.

Mirrored volumes: A mirrored volume is a fault-tolerant volume that duplicates your data on two physical disks. If one of the physical disks fails, the data on the failed disk becomes unavailable, but the system continues to operate using the unaffected disk.

Module: a Midplane Board with all its connected components and utility devices. See CSS Module and MP.

MQB: Midplane QBB board. The MQB connects one or two QBBs and one or two IPDs. See QBB and IPD.

MSX: Midplane SPS & XPS board. The MSX houses a B-SPS switch and is connected to the MIO and the MQB. There are two MSX boards in a CSS module. All SP connections between a QBB and an IOC use an MSX. See B-SPS, MIO, MQB.

MTBF: Mean Time Between Failure. An indicator of expected system reliability calculated on a statistical basis from the known failure rates of various components of the system. Note: MTBF is usually expressed in hours.

Multicore: Presence of two or more processors on a single chip.

Multimedia: Information presented through more than one type of media. On computer systems, this media includes sound, graphics, animation and text.

Multitasking: The ability to perform several tasks simultaneously. Multitasking allows you to run multiple applications at the same time and exchange information among them. See Task.

Multithreading: The ability of a processor core to execute more than one independent instruction thread simultaneously. As the core comprises two complete context registers, it is able to switch rapidly from one instruction thread to another.

N

NFS: Network File System. A proprietary distributed file system that is widely used by TCP/IP vendors.
Note: NFS allows different computer systems to share files, and uses user datagram protocol (UDP) for data transfer.

NMI: Non-Maskable Interrupt.

NUMA: Non Uniform Memory Access. A method of configuring a cluster of microprocessors in a multiprocessing system so that they can share memory locally, improving performance and the ability of the system to be expanded.

nsh: nsh stands for new shell. See Shell and EFI Shell.

NVRAM: Non Volatile Random Access Memory. A type of RAM that retains its contents even when the computer is powered off. See RAM and SRAM.

O

OF: Open Firmware. Firmware controlling a computer prior to the Operating System.

Operating System: See OS.

OS: Operating System. The software which manages computer resources and provides the operating environment for application programs.

P

PAL: Processor Abstraction Layer: processor firmware that abstracts processor implementation differences. See also SAL.

PAM: Platform Administration & Maintenance.

PAM software: Platform Administration & Maintenance software. One part (PAP application and the PamSite WEB site) runs on the PAP unit. The other part (MAESTRO) is embedded on the PMB board.

PAM Tree pane: One of the three areas of the PAM web page. Server hardware presence and functional status are displayed in the PAM Tree pane. See Status pane and Control pane.

PAP unit: Platform Administration Processor unit. The PC hosting all server administration software.

PAP application: Platform Administration Processor application. Part of PAM software, PAP application is a Windows COM+ application running on PAP unit.

Parallel Port: Connector allowing the transfer of data between the computer and a parallel device.

PARM request: the PARM application is designed to handle Requests issued by the CSE (Customer Service Engineer)

Partition: Division of storage space on a hard disk into separate areas so that the operating system treats them as separate disk drives.

Password: A security feature that prevents an unauthorized user from operating the system.

PCI: Peripheral Component Interconnect. Bus architecture supporting high-performance peripherals.

PD: Physical Disk. A Storeway FDA 1300/2300 physical disk is not visible to the OS. See LD.

PDU: Power Distribution Unit. Power bus used for the connection of peripheral system components.

Permanence: Property of a history file that determines whether or not the history file can be modified or deleted from the PAM user interface. Permanence is either *Static* (cannot be modified) or *Dynamic* (can be modified).

P-HPB: PCI Hot Plug Board. This board provides an interlock switch on each IO Box PCI slot for hot-swapping PCI boards. See HPB.

PIC: Platform Instrumentation Control.

ping: A basic Internet program that lets you verify that a particular IP address exists and can accept requests. The verb "to ping" means the act of using the ping utility or command.

PIROM: Processor Information ROM. Processor Information ROM (PIROM) contains information about the specific processor in which it resides. This information includes robust addressing headers to allow for flexible programming and forward compatibility, core and L2 cache electrical specifications, processor part and S-spec numbers, and a 64-bit processor number.

PMB: Platform Management Board. Links the server to the PAP unit.

PNP: Plug and Play. The ability to plug a device into a computer and have the computer recognize that the device is there.

POST: Power On Self Test. When power is turned on, POST (Power-On Self-Test) is the diagnostic testing sequence (or "starting program") that a computer runs to determine if hardware is working correctly.

PROM: Programmable Read-Only Memory.

PUID: PAM Universal/Unique Identifier. PAM software allocates a PUID (PAM Universal / Unique Identifier) to each hardware / software object to guarantee unambiguous identification.

The PUID for each hardware element can be obtained by hovering the mouse over the corresponding element in the PAM tree, e.g.:

PAM:/CELLSBLOCK_<NAME>/MODULE_x/QBB_y/CPU_y.

Q

QBB: Quad Brick Board. The QBB is the heart of the Bull NovaScale Server, housing 4 Itanium® 2 processors and 16 DIMMs. Each QBB communicates with other CSS Module components via 2 high-speed bidirectional Scalability Port Switches. See SPS or FSS.

R

RAID: Redundant Array of Independent Disks. A method of combining hard disk drives into one logical storage unit for disk-fault tolerance.

RAM: Random Access Memory. A temporary storage area for data and programs. This type of memory must be periodically refreshed to maintain valid data and is lost when the computer is powered off. See NVRAM and SRAM.

RAS: Reliability, Availability, Serviceability.

Real-time clock: The Integrated Circuit in a computer that maintains the time and date.

RFI: Radio Frequency Interference.

Ring: The CSS module interconnection ring comprises the cables used to interconnect two, three or four CSS modules.

RJ45: 8-contact regular jack.

RMC: Remote Maintenance Console.

ROM: Read-Only Memory. A type of memory device that is used to store the system BIOS code. This code cannot be altered and is not lost when the computer is powered off. See BIOS, EPROM and Flash EPROM.

RS-232 Port: An industry standard serial port. See Serial Port.

RSF: Remote Service Facilities.

RTC: Real Time Clock.

S

S@N.IT: SAN Administration Tool.

SAL: System Abstraction Layer. Firmware that abstract system implementation differences in IA-64 platform. See also PAL.

SAN: Storage Area Network. A high-speed special-purpose network that interconnects different kinds of data storage devices with associated data servers on behalf of a larger network of users.

SAPIC: Streamlined Advanced Programmable Interrupt Controller message.

SBE: Single Bit Error.

Scheme: Configuration file ensuring optimum use and compatibility of the physical and logical resources used to simultaneously run multiple domains.

SCI: Scalable Coherent Interface.

SCSI: Small Computer System Interface. An input and output bus that provides a standard interface used to connect peripherals such as disks or tape drives in a daisy chain.

SDR: Sensor Data Record.

SDRAM: Synchronous Dynamic Random Access Memory. A type of DRAM that runs at faster clock speeds than conventional memory. See DRAM.

SEL: System Event Log. A record of system management events. The information stored includes the name of the event, the date and time the event occurred and event data. Event data may include POST error codes that reflect hardware errors or software conflicts within the system.

Serial Communication: Data sent sequentially, one bit at a time.

Serial Port: Connector that allows the transfer of data between the computer and a serial device. See COM1 or COM 2. Shell is a Unix term for the interactive user interface with an operating system.

SIO: Server I/O / Super I/O.

Shell: The Shell is the layer of programming that understands and executes the commands a user enters. As the outer layer of an operating system, the Shell can be contrasted with the kernel, the inmost layer or core of services of an operating system. See EFI Shell.

SIOH: Server I/O Hub. This component provides a connection point between various I/O bridge components and the Intel 870 chipset.

Sideband: This part of the CSS module inter-connection ring comprises logistic cables (errors, commands, resets). See Ring.

SMBIOS: System Management BIOS.

SM-BUS: System Management Bus.

SMIC: Server Management Interface Chip.

SMP: Symmetrical Multi Processor. The processing of programs by multiple processors that share a common operating system and memory.

SNC: Scalable Node Controller. The processor system bus interface and memory controller for the Intel 870 chipset. The SNC supports both the Itanium2 processors, DDR SDRAM main memory, a Firmware Hub Interface to support multiple Firmware hubs, and two scalability ports for access to I/O and coherent memory on other nodes, through the FSS.

SNM: System Network Module.

SNMP: Simple Network Management Protocol. The protocol governing network management and the monitoring of network devices and their functions.

Socket: Central Processing Unit multicore interface. Each socket can house 1 or 2 processor cores. See Microprocessor and CPU.

Source: Each message refers to a source (the resource that generated the message) and a target (the component referred to in the message). This feature can be allows messages to be filtered according to one or more Source string(s) and is particularly useful for debugging and troubleshooting. See Target.

SPD: Serial Presence Detect. DIMM PROM.

SPS: Scalability Port Switch. Each CSS Module is equipped with 2 Scalability Port Switches providing high speed bi-directional links between system components. See FSS.

SRAM: Static RAM. A temporary storage area for data and programs. This type of memory does not need to be refreshed, but is lost when the system is powered off. See NVRAM and RAM.

SSI: Server System Infrastructure.

Status Pane: One of the three areas of the PAM web page. Provides quick access to CSS Module availability status, server functional status, and pending event message information. See also Control pane and PAM Tree pane.

SVGA: Super Video Graphics Array.

T

Target: Each message refers to a target (the component referred to in the message), identified by its PUID, and a source (the component that generated the message). This feature allows messages to be filtered according to one or more Target string(s) and is particularly useful for debugging and troubleshooting. See Source and PUID.

Task: Each message refers to a target (the component referred to in the message), identified by its PUID, and a source (the component that generated the message). This feature allows messages to be filtered according to one or more Target string(s) and is particularly useful for debugging and troubleshooting. See Source and PUID.

TCP: Transmission Control Protocol. A set of rules (protocol) used along with the Internet Protocol (IP) to send data in the form of message units between computers over the Internet.

TCP/IP: Transmission Control Protocol / Internet Protocol. The basic communication language or protocol of the Internet.

T&D: Tests and Diagnostics.

Thresholding: A PAM Event filter criterion. Thresholding is defined on a Count / Time basis aimed at routing significant messages only. Identical messages are counted and when the number of messages indicated in the Count field is reached within the period of time indicated in the Time field, this message is selected for routing.

U

UART: a Universal Asynchronous Receiver Transmitter. The microchip with programming that controls a computer interface to its attached serial devices.

ULTRA SCSI: An enhanced standard 16-bit SCSI interface providing synchronous data transfers of up to 20 MHz, with a transfer speed of 40M bytes per second. It is also called Fast-20 SCSI.

UML: Unified Modeling Language. A standard notation for the modeling of real-world objects as a first step in developing an object-oriented design methodology.

UPS: Uninterruptible Power Supply. A device that allows uninterrupted operation if the primary power source is lost. It also provides protection from power surges.

URL: Uniform / Universal Resource Locator. The address of a file (resource) accessible on the Internet.

USB: Universal Serial Bus. A plug-and-play interface between a computer and add-on devices. The USB interface allows a new device to be added to your computer without having to add an adapter card or even having to turn the computer off.

V

VCC: Voltage Continuous Current.

VGA: Video Graphics Array.

VI: Virtual Interface.

Visibility: A property of a history file. Visibility is either *System* (the history file is predefined by the PAM software and is visible only to an administrator) or *User* (the history file is created by an administrator and is visible to both an administrator and an operator).

VLAN: Virtual Local Area Network. A local area network with a definition that maps workstations on some other basis than geographic location (for example, by department, type of user, or primary application).

VxWORKS: Platform Management Board Operating System.

W

WAN: Wide Area Network. Geographically dispersed telecommunications network. The term distinguishes a broader telecommunication structure from a local area network (LAN).

WBEM: Web Based Enterprise Management.

WMI: Windows Management Interface.

WOL: A feature that provides the ability to remotely power on a system through a network connection.

X

XML: eXtended Markup Language. A flexible way to create common information formats and share both the format and the data on the World Wide Web, intranets, and elsewhere.

XSP: eXtended Scalable Port.

Y

No entries.

Z

No entries.

Index

C

Cabinet

- inspecting, 1-10
- jacking screws, 1-12
- models, 1-2
- moving, 1-11
- packing, 1-3
- relocating, 1-11
- securing, 1-12
- service clearance, 1-8
- specifications, A-1
- unloading, 1-8

Cables

- data, 3-1
- inter-cabinet, 3-1
- power, 3-1
- routing, 3-1

Compatibility, server / device, 1-16

Connecting, PDU, 3-2

D

Data, cables, 3-1

Data cables, routing, 3-1

Devices, installing, 1-15

E

Equipment tray, fitting, 1-17

Electrical safety, x

F

Flange hole, size, 1-16

Front door

- installing, 1-13
- removing, 1-13

I

Installing

- devices, 1-15
- PDU, 1-18
- servers, 1-15

Inter-cabinet cables, routing, 3-1

J

Jacking screws, lowering, 1-12

L

Labels, shockwatch, 1-3

Laser safety, xi

M

Models

- cabinet, 1-2
- PDU, 1-3

N

Notices

- electrical safety, x
- laser safety, xi
- safety, x

P

Packing

- cabinet, 1-3
- storing, 1-7

Packing items

- removing, 1-6
- storing, 1-6

PDU

- connecting, 3-2
- installing, 1-18
- models, 1-3
- specifications, A-1

PDU model

- PDU 24A 4x C13 2x C19 US, 1-4
- PDU 32A 12x C13 EU, 1-6
- PDU- 63A 2x C13 4x C19 EU, 1-5

PDU models, PDU 32A 7x C13 EU, 1-5

Power cables, PDU, 3-2

Power supply, connecting a PDU, 3-2

R

Rear door

- installing, 1-13
- removing, 1-13

Relocating, cabinet, 1-11

Routing

- data cables, 3-1
- inter-cabinet cables, 3-1
- power cables, 3-1

S

Safety

- notices, x
- recommendations, 3-2

Server / Device, compatibility, 1-16

Server components, PDU power cable, 3-2

Servers, installing, 1-15

Service clearance, cabinet, 1-8

Shockwatch, labels, 1-3

Side panel

- installing, 1-14
- removing, 1-14

Specifications

- cabinet, A-1
- PDU, A-1

U

Unloading, cabinet, 1-8

Bull Cedoc
357 avenue Patton
BP 20845
49008 Angers Cedex 01
FRANCE

REFERENCE
86 A1 17FA 00