

R@ck'n Roll & R@ck-to-Build

Installation and Service Guide

R@CK'N ROLL &
R@CK-TO-BUILD



REFERENCE
86 A1 17FA 01

R@CK'N ROLL & R@CK-TO-BUILD

R@ck'n Roll & R@ck-to-Build

Installation and Service Guide

Hardware

December 2008

Bull Cedoc
357 avenue Patton
BP 20845
49008 Angers Cedex 01
FRANCE

REFERENCE
86 A1 17FA 01

The following copyright notice protects this book under Copyright laws which prohibit such actions as, but not limited to, copying, distributing, modifying, and making derivative works.

Copyright ©Bull SAS 2008

Printed in France

Trademarks and Acknowledgements

We acknowledge the right of proprietors of trademarks mentioned in this manual.

All brand names and software and hardware product names are subject to trademark and/or patent protection.

Quoting of brand and product names is for information purposes only and does not represent trademark misuse.

The information in this document is subject to change without notice. Bull will not be liable for errors contained herein, or for incidental or consequential damages in connection with the use of this material.

Table of Contents

Preface	vii
Intended Readers	vii
Highlighting	vii
Related Publications	viii
Regulatory Declarations and Disclaimers	ix
Declaration of the Manufacturer or Importer	ix
Safety Compliance Statement	ix
European Community (EC) Council Directives	ix
Electromagnetic Compatibility	ix
Low Voltage	ix
EC Conformity	ix
Telecommunications Terminal Equipment	ix
FCC Declaration of Conformity	ix
Federal Communications Commission (FCC) Statement	x
Canadian Compliance Statement (Industry Canada)	x
Laser Compliance Notice	x
Safety Information	x
Definition of Safety Notices	x
Electrical Safety	xi
Laser Safety Information	xi
Data Integrity and Verification	xi
Waste Management	xii
Chapter 1. Overview	1-1
1.1. Cabinet Models	1-2
1.1.1. R@ck'n Roll Cabinet	1-2
1.1.2. R@ck-to-Build Cabinet	1-2
1.2. PDU Models	1-3
1.2.1. PDU 32A, 4xC13 - 2xC19, EU	1-4
1.2.2. PDU 24A, 4xC13 - 2xC19, US	1-5
1.2.3. PDU 63A, 2xC13 - 4xC19, EU	1-6
1.2.4. PDU 32A, 7xC13, EU	1-7
1.2.5. PDU 32A, 12xC13, EU	1-8
Chapter 2. Installing and Servicing Cabinets	2-1
2.1. General Recommendations	2-2
2.2. Inspecting Cabinet Packing	2-3
2.2.1. Storing Packing Items	2-3
2.2.2. Unpacking and Depalletizing Label	2-5
2.3. Removing and Storing Packing Items	2-6
2.3.1. Remove Standard Packing Items	2-6
2.3.2. Remove Reinforced Packing Items	2-7

2.3.3.	Storing Packing Items	2-7
2.4.	Unloading the Cabinet	2-8
2.4.1.	Service Clearance	2-8
2.4.2.	Unpacking the R@ck'n Roll Cabinet	2-9
2.4.3.	Depalletizing the R@ck'n Roll Cabinet	2-9
2.5.	Inspecting the Cabinet	2-10
2.6.	Moving the Cabinet	2-11
2.7.	Securing the Cabinet	2-12
2.8.	Removing/Installing/Turning the Doors and Side Panels	2-13
2.8.1.	Removing the Front Door	2-13
2.8.2.	Installing the Front Door	2-14
2.8.3.	Removing the Rear Door	2-15
2.8.4.	Installing the Rear Door	2-16
2.8.5.	Turning the Front/Rear Door	2-17
2.8.6.	Removing a Side Panel	2-18
2.8.7.	Installing a Side Panel	2-19
2.9.	Installing the Cool Cabinet Door	2-20
2.10.	Installing Servers and Devices	2-20
2.11.	Fitting Equipment Trays	2-22
2.12.	Installing a PDU	2-23

Chapter 3. Managing Power and Data Cables **3-1**

3.1.	Routing Data Cables	3-1
3.2.	Preparing a PDU for connection to the Site Power Supply	3-2

Appendix A. Specifications **A-1**

A.1.	R@ck'n Roll Cabinet Specifications	A-2
A.2.	R@ck-to-Build Cabinet Specifications	A-2
A.3.	PDU Common Electrical Specifications	A-3
A.4.	PDU 63A, 2xC13 - 4xC19, EU Specifications	A-4
A.5.	PDU 32A, 4xC13 - 2xC19, EU Specifications	A-4
A.6.	PDU 32A, 7xC13, EU Specifications	A-5
A.7.	PDU 32A, 12xC13, EU Specifications	A-5
A.8.	PDU 24A, 4xC13 - 2xC19, US Specifications	A-6

Index **x-1**

List of Figures

Figure 1.	Cabinet features	1-2
Figure 2.	PDU 32A, 4xC13 - 2xC19, EU features -vertical / horizontal installation	1-4
Figure 3.	PDU 24A, 4xC13 - 2xC19, US features -vertical / horizontal installation	1-5
Figure 4.	PDU 63A, 2xC13 - 4xC19, EU features - vertical / horizontal installation	1-6
Figure 5.	PDU 32A, 7xC13, EU features - vertical / horizontal installation	1-7
Figure 6.	PDU 32A, 12xC13, EU features - vertical/horizontal installation	1-8
Figure 7.	Packing Warning Label	2-3
Figure 8.	Packing shockwatch label	2-4
Figure 9.	R@ck'n Roll Cabinet Unpacking and Depalletizing label	2-5
Figure 10.	Removing standard packing items	2-6
Figure 11.	Removing reinforced packing items	2-7
Figure 12.	Required unpacking area	2-8
Figure 13.	Cabinet service clearance	2-11
Figure 14.	Removing the front door	2-13
Figure 15.	Installing the front door	2-14
Figure 16.	Removing the rear door	2-15
Figure 17.	Installing the rear door	2-16
Figure 18.	Opening side panel locks	2-18
Figure 19.	Removing a side panel	2-18
Figure 20.	Installing a side panel	2-19
Figure 21.	Closing side panel locks	2-19
Figure 22.	Internal cabinet dimensions	2-21
Figure 23.	Mounting flange hole size and placement	2-22
Figure 24.	Installing a PDU horizontally	2-23
Figure 25.	Installing a PDU vertically	2-24
Figure 26.	Power plug and socket	3-2
Figure 27.	PDU/UPS Power socket	3-3

List of Tables

Table 1.	R@ck'n Roll Cabinet Specifications	A-2
Table 2.	R@ck-to-Build Cabinet Specifications	A-2
Table 3.	PDU common specifications	A-3
Table 4.	PDU 63A, 2xC13 - 4xC19, EU specifications	A-4
Table 5.	PDU 32A, 4xC13 - 2xC19, EU specifications	A-4
Table 6.	PDU 32A, 7xC13, EU specifications	A-5
Table 7.	PDU 32A, 12xC13, EU specifications	A-5
Table 8.	PDU 24A, 4xC13 - 2xC19, US specifications	A-6

Preface

This guide explains how to mount, commission and service the Bull R@ck'n Roll and R@ck-to-Build Cabinets.

Intended Readers

This guide is intended for use by qualified personnel in charge of installing and servicing Bull R@ck'n Roll Cabinet and R@ck-to-Build Cabinet.



Important

Detailed installation and servicing instructions for rack-mountable servers and/or devices are provided in the documentation delivered with these servers and/or devices.

Detailed installation and servicing instructions of the Cool Cabinet Door are provided in the documentation delivered with the door and listed under Related Publications below.



DANGER

Personnel are requested to carefully read the Safety Notices set out in Appendix A before installing or servicing cabinets.

Highlighting

The following highlighting conventions are used in this guide:

Bold	Identifies the following: <ul style="list-style-type: none">• Interface objects such as menu names, labels, buttons and icons.• File, directory and path names.• Keywords to which particular attention must be paid.
<i>Italics</i>	Identifies references such as manuals or URLs.
<code>monospace</code>	Identifies portions of program codes, command lines, or messages displayed in command windows.
< >	Identifies parameters to be supplied by the user.

Related Publications

- *Site Preparation Guide 86A140FA*
explains how to prepare a Data Processing Center for Bull equipments, in compliance with the standards in force. This guide is intended for use by all personnel and trade representatives involved in the site preparation process.
- *Cool Cabinet Door Installation and Service Guide 86A742FA*
explains how to mount, commission, and service the Cool Cabinet Door option for the R@ck'n Roll Cabinet.
- *Cool Cabinet Console User's Guide, 86A141FA*
explains how to use the Cool Cabinet administration console. This guide is intended for use by Customer Administrators and Operators.
- *Unpacking & Depalletizing Label/Étiquette de Déballage & Dépalettisation*
shows the label attached on the cabinet front door. It indicates the recommended way to unpack and depalletize the Rck'n Roll Cabinet.

Regulatory Declarations and Disclaimers

Declaration of the Manufacturer or Importer

We hereby certify that this product is in compliance with European Union EMC Directive 2004/108/EC, using standards EN55022 (Class A) and EN55024 and Low Voltage Directive 2006/95/EC, using standard EN60950. The product has been marked with the CE Mark to illustrate its compliance.

Safety Compliance Statement

- UL 60950 (USA)
- IEC 60950 (International)
- CSA 60950 (Canada)

European Community (EC) Council Directives

This product is in conformity with the protection requirements of the following EC Council Directives:

Electromagnetic Compatibility

- 2004/108/EC

Low Voltage

- 2006/95/EC

EC Conformity

- 93/68/EEC

Telecommunications Terminal Equipment

- 1999/5/EC

Neither the provider nor the manufacturer can accept responsibility for any failure to satisfy the protection requirements resulting from a non-recommended modification of the product.

Compliance with these directives requires:

- An EC declaration of conformity from the manufacturer.
- An EC label on the product.
- Technical documentation.

FCC Declaration of Conformity

This device complies with Part 15 of the FCC Rules. Operation is subject to the following two conditions: (1) this device may not cause harmful interference, and (2) this device must accept any interference received, including interference that may cause undesired operation.

Federal Communications Commission (FCC) Statement

This equipment has been tested and found to comply with the limits for a Class A digital device, pursuant to Part 15 of the FCC Rules. These limits are designed to provide reasonable protection against harmful interference when the equipment is operated in a commercial environment. This equipment generates, uses, and can radiate radio frequency energy and, if not installed and used in accordance with the instruction manual, may cause harmful interference to radio communications. Operation of this equipment in a residential area is likely to cause harmful interference in which case the user will be required to correct the interference at his own expense.

Properly shielded and grounded cables and connectors must be used in order to meet FCC emission limits. Neither the provider nor the manufacturer are responsible for any radio or television interference caused by using other than recommended cables and connectors or by unauthorized changes or modifications to this equipment. Unauthorized changes or modifications could void the user's authority to operate the equipment.

Pursuant to Part 15.21 of the FCC Rules, any changes or modifications to this equipment not expressly approved by BULL SAS may cause harmful interference and void the FCC authorization to operate this equipment.

An FCC regulatory label is affixed to the equipment.

Canadian Compliance Statement (Industry Canada)

This Class A digital apparatus meets all requirements of the Canadian Interference Causing Equipment Regulations.

Cet appareil numérique de la classe A est conforme à la norme NMB-003 du Canada.

This product is in conformity with the protection requirements of the following standards:

- ICES-003
- NMB-003

Laser Compliance Notice

This product that uses laser technology complies with Class 1 laser requirements.

A CLASS 1 LASER PRODUCT label is affixed to the laser device.

Class 1 Laser Product Luokan 1 Laserlaite Klasse 1 Laser Apparat Laser Klasse 1
--

Safety Information

Definition of Safety Notices



DANGER

A *Danger* notice indicates the presence of a hazard that has the potential of causing death or serious personal injury.



CAUTION

A *Caution* notice indicates the presence of a hazard that has the potential of causing moderate or minor personal injury.



WARNING

A *Warning* notice indicates an action that could cause damage to a program, device, system, or data.

Electrical Safety

The following safety instructions shall be observed when connecting or disconnecting devices to the system.



DANGER

The Customer is responsible for ensuring that the AC electricity supply is compliant with national and local recommendations, regulations, standards and codes of practice. An incorrectly wired and grounded electrical outlet may place hazardous voltage on metal parts of the system or the devices that attach to the system and result in an electrical shock. It is mandatory to remove power cables from electrical outlets before relocating the system.



CAUTION

This unit has more than one power supply cable. Follow procedures for removal of power from the system when directed.

Laser Safety Information

The optical drive in this system unit is classified as a Class 1 level Laser product. The optical drive has a label that identifies its classification.

The optical drive in this system unit is certified in the U.S. to conform to the requirements of the Department of Health and Human Services 21 Code of Federal Regulations (DHHS 21 CFR) Subchapter J for Class 1 laser products. Elsewhere, the drive is certified to conform to the requirements of the International Electrotechnical Commission (IEC) 60825-1: 2001 and CENELEC EN 60825-1: 1994 for Class 1 laser products.



CAUTION

Invisible laser radiation when open. Do not stare into beam or view directly with optical instruments.

Class 1 Laser products are not considered to be hazardous. The optical drive contains internally a Class 3B gallium-arsenide laser that is nominally 30 milliwatts at 830 nanometers. The design incorporates a combination of enclosures, electronics, and redundant interlocks such that there is no exposure to laser radiation above a Class 1 level during normal operation, user maintenance, or servicing conditions.

Data Integrity and Verification



WARNING

Bull product is designed to reduce the risk of undetected data corruption or loss. However, if unplanned outages or system failures occur, users are strongly advised to check the accuracy of the operations performed and the data saved or transmitted by the system at the time of outage or failure.

Waste Management

This product has been built to comply with the Restriction of Certain Hazardous Substances (RoHS) Directive 2002/95/EC.

This product has been built to comply with the Waste Electrical and Electronic (WEEE) Directive 2002/96/EC.

Chapter 1. Overview

This chapter presents the different cabinet and power distribution unit models. It includes the following topics:

- Cabinet Models, on page 1-2
- PDU Models, on page 1-3

1.1. Cabinet Models

Two cabinet models are available: R@ck'n Roll Cabinet and R@ck-to-Build Cabinet.



Figure 1. Cabinet features

Note 1 U = 44.45 mm (1.75 in).
Maximum allowable thermal dissipation: 40 KW /42U per cabinet.

1.1.1. R@ck'n Roll Cabinet

The R@ck'n Roll Cabinet is 600 mm wide, 42-U high and 1100 mm deep and delivers rack-integrated, factory-assembled, ready-to-use solutions.

The R@ck'n Roll Cabinet can be shipped loaded and goes through standard doorways, once depalletized, on its castors.

1.1.2. R@ck-to-Build Cabinet

The R@ck-to-Build Cabinet is 600 mm wide, 42-U high and 1100 mm deep and allows customers to install equipment on site.

The R@ck-to-Build Cabinet is shipped empty and goes through standard doorways, once depalletized, on its castors.

1.2. PDU Models

- PDU 32A, 4xC13 - 2xC19, EU, on page 1-4
- PDU 24A, 4xC13 - 2xC19, US, on page 1-5
- PDU 63A, 2xC13 - 4xC19, EU, on page 1-6
- PDU 32A, 7xC13 EU, on page 1-7
- PDU 32A, 12xC13 EU, on page 1-8

According to type, the PDUs allow you to connect six, seven, or twelve servers and/or devices to a single dedicated power supply outlet.

All PDUs can be installed both vertically and horizontally in the cabinet. Refer to the documentation delivered with the PDU for detailed installation instructions.

Note See Appendix A for further details.



CAUTION

France:

Power sockets and plugs must be compliant with Decree 88-1056 Article 20-IV, dated 14th November 1988.

1.2.1. PDU 32A, 4xC13 - 2xC19, EU

The PDU 32A, 4xC13 - 2xC19, EU allows you to connect up to six servers and/or devices. It offers the following features:

Phase	Single phase	Mains Connectors	IEC60309-32A
Max. Current	32 A	9A (C13) Outlets	4
Max. Voltage	240 VAC	14.5A (C19) Outlets	2
Mains Cable	3xAWG10 (2 m lenght)	Breakers	6 (9A / C13 breaker, 14.5A /C19 breaker)

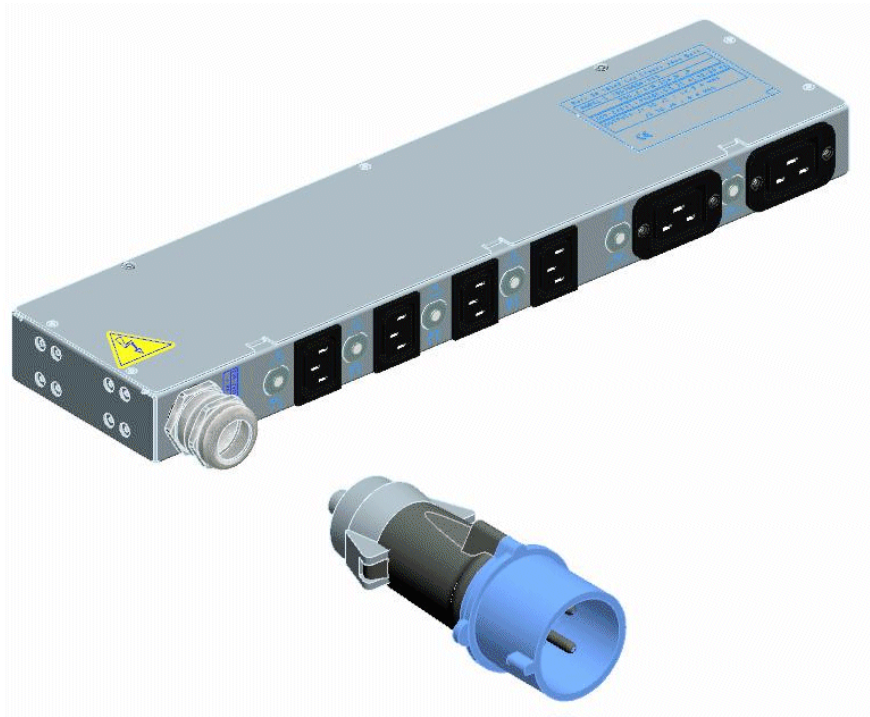

Figure 2. PDU 32A, 4xC13 - 2xC19, EU features -vertical / horizontal installation

1.2.2. PDU 24A, 4xC13 - 2xC19, US

The PDU 24A, 4xC13 - 2xC19, US allows you to connect up to six servers and/or devices. It offers the following features:

Phase	Single phase	Mains Connectors	USL6-30P-24A
Max. Current	20 A	8A (C13) Outlets	4
Max. Voltage	240 VAC	16A (C19) Outlets	2
Mains Cable	3xAWG10 (2 m length)	Breakers	2 (1x C13 breaker, 1x C19 breaker)



Figure 3. PDU 24A, 4xC13 - 2xC19, US features -vertical / horizontal installation

1.2.3. PDU 63A, 2xC13 - 4xC19, EU

The PDU 63A, 2xC13 - 4xC19, EU allows you to connect up to six servers and/or devices. It offers the following features:

Phase	Single phase	Mains Connectors	IEC60309-63A
Max. Current	63 A	14.5A (C19) Outlets	4
Max. Voltage	240 VAC	9A (C13) Outlets	2
Mains Cable	3xAWG06 (2 m length)	Breakers	6 (9A / C13 breaker, 14.5A /C19 breaker)



Figure 4. PDU 63A, 2xC13 - 4xC19, EU features - vertical / horizontal installation

1.2.4. PDU 32A, 7xC13, EU

The PDU 32A, 7xC13, EU allows you to connect up to seven servers and/or devices. It offers the following features:

Phase	Single phase	Mains Connectors	IEC60309-32A
Max. Current	32 A	14.5A (C19) Outlets	0
Max. Voltage	240 VAC	9A (C13) Outlets	7
Mains Cable	3xAWG10 (2 m length)	Breakers	7 (9A /C13 breaker)

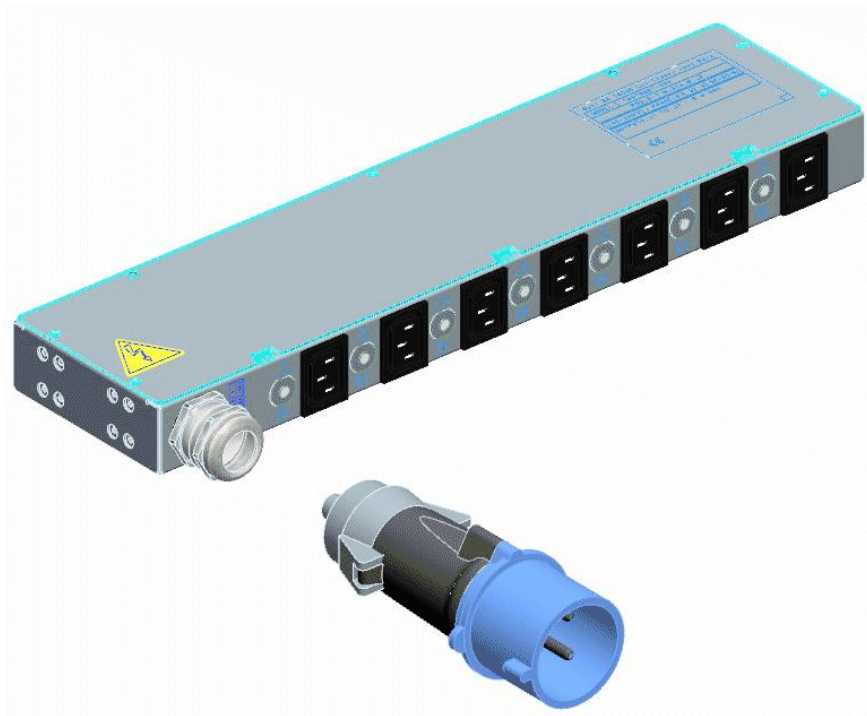

Figure 5. PDU 32A, 7xC13, EU features - vertical / horizontal installation

1.2.5. PDU 32A, 12xC13, EU

The PDU 32A, 12xC13, EU allows you to connect up to twelve servers and/or devices. It offers the following features:

Phase	Single phase	Mains Connectors	IEC60309-32A
Max. Current	32 A	14.5A (C19) Outlets	0
Max. Voltage	240 VAC	9A (C13) Outlets	12
Mains Cable	3xAWG10 (2 m length)	Breakers	4 (9A /C13 breaker)

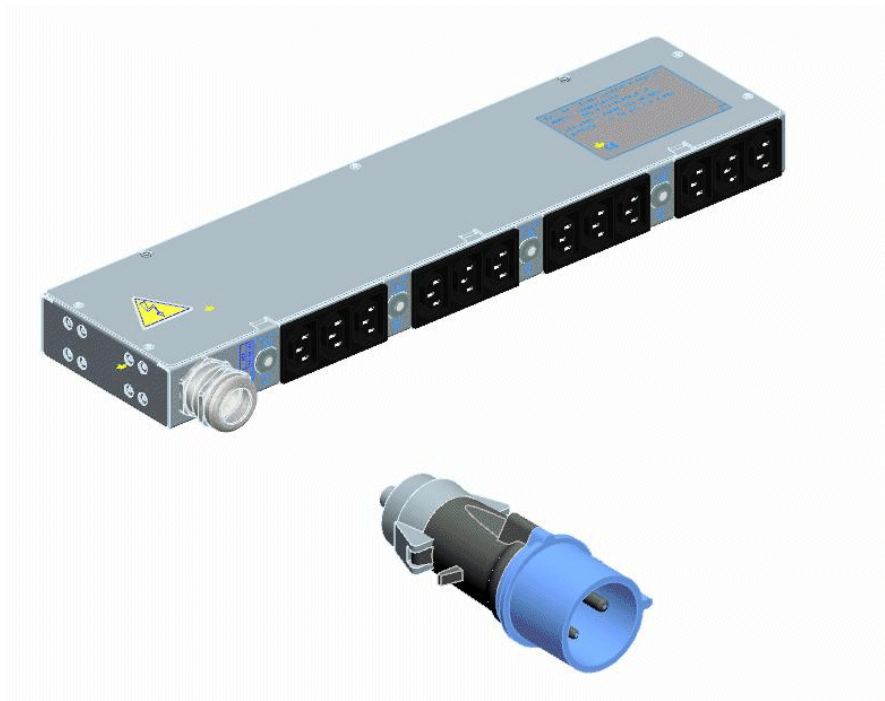

Figure 6. PDU 32A, 12xC13, EU features - vertical/horizontal installation

Chapter 2. Installing and Servicing Cabinets

This chapter explains how to unpack, install, and service the cabinets. It includes the following topics:

- General Recommendations, on page 2-2
- Inspecting Cabinet Packing, on page 2-3
- Removing and Storing Packing Items, on page 2-6
- Unloading the Cabinet, on page 2-8
- Inspecting the Cabinet, on page 2-10
- Moving the Cabinet, on page 2-11
- Securing the Cabinet, on page 2-12
- Removing/Installing/Turning the Doors and Side Panels, on page 2-13
- Installing Servers and Devices, on page 2-20
- Fitting Equipment Trays, on page 2-22
- Installing a PDU, on page 2-23



CAUTION

All servers and devices installed in the cabinets must be compliant with national safety regulations.

2.1. General Recommendations

Cabinets may be delivered either equipped with servers and devices or empty, according to the model chosen.

Site preparation must be completed by the pre-arranged delivery date.
Any delay due to non-completion of the site by the pre-arranged date will be considered as the Customer's responsibility.

Note R@ck'n Roll Cabinet unpacking and depalletizing instructions are clearly set out on a label attached to the cabinet door. See Figure 9 R@ck'n Roll Cabinet Unpacking and Depalletizing label, on page 2-5



CAUTION

The Data Processing Site manager must allocate enough personnel to ensure safe handling.



DANGER

The loaded R@ck'n Roll Cabinet or R@ck-to-Build Cabinet may be extremely heavy and require the use of an elevator.

It is mandatory for the loaded R@ck'n Roll Cabinet to be transported vertically.



Important The Data Processing Site manager must set aside the required working area for unpacking as shown in Figure 12 Service Clearance, on page 2-8.

2.2. Inspecting Cabinet Packing

The following packing items are used to protect cabinets during shipping:

- top, front, rear protective covers,
- pallet,
- plastic and velcro straps,
- shockwatch and tiltwatch labels.

A box, labeled **Open Me First** is delivered with each cabinet. This box contains:

- one front stabilizer and fixtures (optional),
- hoisting fixtures (optional),
- this document.

R@ck'n Roll Cabinet unpacking and depalletizing instructions are clearly set out on a label attached to the cabinet door.

2.2.1. Storing Packing Items

Before unpacking, check the indicators on the 2 shockwatch and 3 tiltwatch labels, positioned as follows on the packing:

- 1 on the front cover
- 1 on the side cover
- 1 on the outer side of the internal front door cover

If one or more of the indicators are RED, the cabinet and/or contents may be damaged. Note indicator status on the bill of lading and carefully inspect the cabinet and contents before powering up servers and devices.



Figure 7. Packing Warning Label

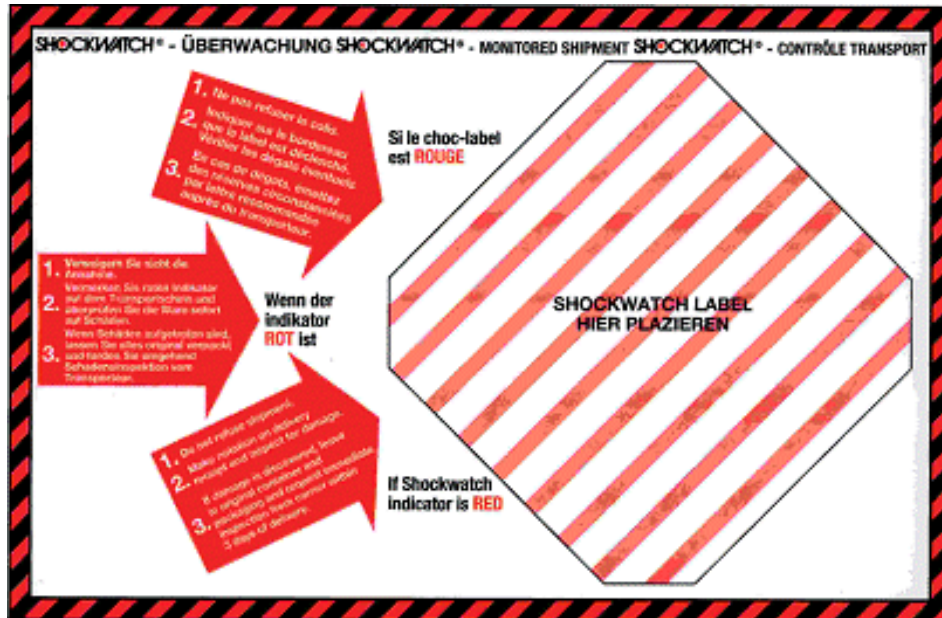

Figure 8. Packing shockwatch label

Note Check the Shockwatch label BEFORE accepting the merchandise.



CAUTION

If the Tiltwatch label is red, make a reserve on the delivery slip and check packing contents.

2.2.2. Unpacking and Depalletizing Label

This label is attached on the cabinet front door and indicates the recommended way to unpack and depalletize the R@ck'n Roll Cabinet.

R@ck'nRoll CABINET: UNPACKING AND DEPALLEITIZING LABEL

1 Unpacking

TOOLING

- Standard pallet truck
- Cutter

SURFACE

- 3m x 3m = 9..m²
- Flat and horizontal

PROCEDURE

- 1 Check the indicators on the external shockwatch and tiltwatch labels.
- 2 Remove the stretch film and elastics with the cutter, taking care not to damage the cabinet.
- 3 Remove the internal protection cover.
- 4 Set packing items aside.



2 Depalletizing

TOOLING

- Cross-threaded screwdriver
- Combination wrench: 10

SURFACE

- 4m x 3m = 12..m²
- Flat and horizontal

DANGER
3 persons at least are required to depalletize the cabinet

PROCEDURE

- 1 Remove the rear door by lifting it off its hinges and set aside.
- 2 Unscrew the M6 screws, bolts and wood screws to free the 2 depalletizing rails located on either side of the pallet.
- 3 Remove the 2 depalletizing rails.
- 4 Align the 2 depalletizing rails with the rear pallet rails and holes. Secure into place with the wood screws.
- 5 Check that the cabinet feet are in the highest position and that the cabinet wheels are correctly aligned on the depalletizing rails.
- 6 Carefully roll the cabinet along the depalletizing rails and off the pallet:
 - 2 persons at least must support the cabinet on the rail side**
 - 1 person at least must guide the cabinet on the opposite side**
- 7 Move the cabinet to the required location and lower the feet to secure it





86 X1 18FA 00

Figure 9. R@ck'n Roll Cabinet Unpacking and Depalletizing label

2.3. Removing and Storing Packing Items



WARNING

To avoid condensation and incorrect handling, cabinets must be removed from their packing by authorized Service personnel **ONLY**, on the scheduled installation date.

Use the Packing Slip to check the number and condition of the shipping boxes prior to unpacking.

Two types of packing are available, according to shipping conditions:

- standard packing, for short-distance deliveries,
- reinforced packing, for long-distance deliveries.

2.3.1. Remove Standard Packing Items

Tools Required

- Cutter



Figure 10. Removing standard packing items

1. Unfasten and remove the stoppers surrounding the cabinet.
2. Remove the stretch film / condensation barrier packing.

2.3.2. Remove Reinforced Packing Items

Tools Required

- Cutter



Figure 11. Removing reinforced packing items

1. Cut the plastic straps with the cutter.
2. Remove the top cover.
3. Remove the rear and front covers by opening the plastic fasteners.
4. Unfasten and remove the stoppers surrounding the cabinet.
5. Remove the stretch film / condensation barrier packing.

2.3.3. Storing Packing Items

All packing items are to be stored in an ancillary room for re-use in the event of relocation or shipping.

2.4. Unloading the Cabinet

The cabinet is delivered on a pallet for easy unloading. It can then be transported on its castors.

-
- Notes**
- The R@ck-to-Build Cabinet can be unloaded and installed by lifting it off the pallet and rolling into place.
 - The R@ck'n Roll Cabinet must be unloaded following the instructions set out below and on the label attached to the cabinet door.
-

2.4.1. Service Clearance

The Data Processing Site manager must set aside the required working area for unpacking as shown in the following figure.

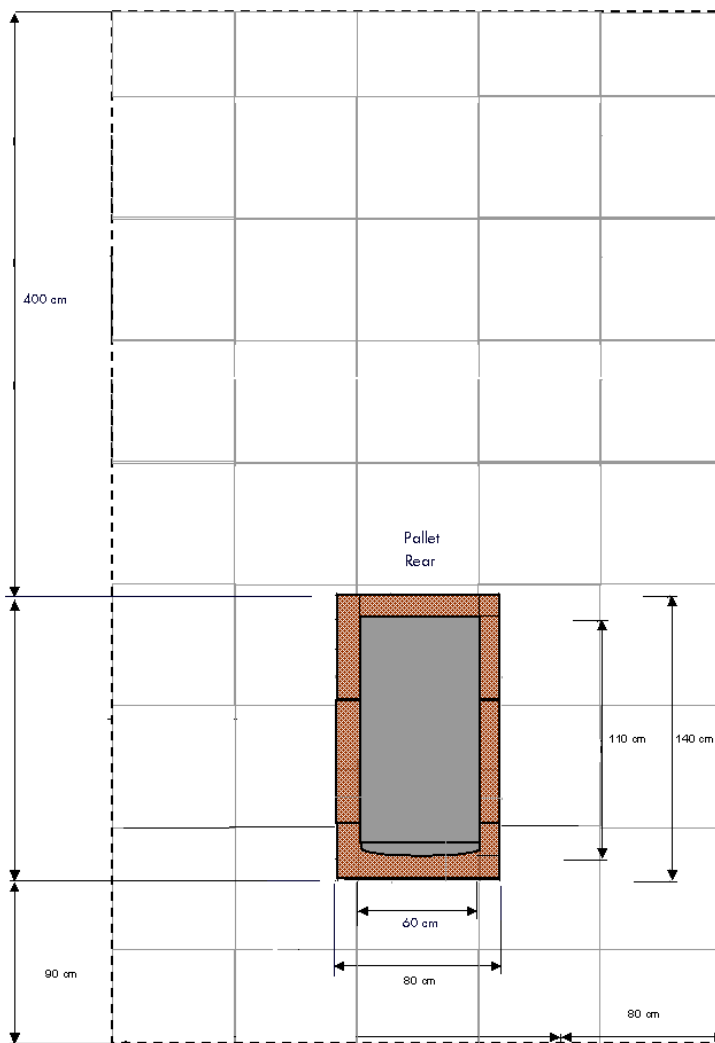

Figure 12. Required unpacking area

2.4.2. Unpacking the R@ck'n Roll Cabinet

Tools required

- Standard pallet truck
- Cutter

Surface

- $3\text{m} \times 3\text{m} = 9\text{ m}^2$
- Flat and horizontal

1. Check the indicators on the external shockwatch and tiltwatch labels.
2. Remove the stretch film and elastics with the cutter, taking care not to damage the cabinet.
3. Remove the internal protection cover.
4. Set packing items aside.

2.4.3. Depalletizing the R@ck'n Roll Cabinet

Tools required

- Cross-threaded screwdriver
- Combination wrench: 10

Surface

- $4\text{m} \times 3\text{m} = 12\text{ m}^2$
- Flat and horizontal



DANGER

Three people at least are required to depalletize the cabinet

1. Remove the rear door by lifting it off its hinges and set aside.
2. Unscrew the M6 screws, bolts and wood screws to free the 2 depalletizing rails located on either side of the pallet.
3. Remove the 2 depalletizing rails and align them with the rear pallet rails.
4. Insert the 2 depalletizing rail snugs in the pallet holes and secure into place with the wood screws.
5. Check that the cabinet feet are in the highest position and that the cabinet wheels are correctly aligned on the depalletizing rails.
6. Carefully roll the cabinet along the depalletizing rails and off the pallet:
2 persons at least must support the cabinet on the rail side
1 person at least must guide the cabinet on the opposite side.
7. Move the cabinet to the required location and lower the feet to secure it into place.
8. Replace the rear door on its hinges.

2.5. Inspecting the Cabinet

Once the cabinet has been unpacked, a preliminary visual inspection must be performed before it is unloaded from the shipping pallet.



CAUTION

Pre-equipped cabinets:

If the inspection indicates an unacceptable safety condition, the condition must be corrected before powering up the server and/or devices inside the cabinet.

1. Check that the delivery is compliant with the Purchase Order.
2. Check that the boxes labeled **Open Me First** and **Unpacking Box** contain the stabilizer and skate-board assemblies.
3. Check covers and doors for sharp edges, damage or alterations.
4. Check the correct fit of covers and doors.
5. Open the front and rear doors.

Note Unlock the front door with the key, pull the handle forwards and upwards to disengage the lock.

6. Check for internal damage, alterations and obvious safety hazards such as broken wires, sharp edges, or broken insulation.
7. Check internal cables for damage.
8. Check for dirt, water, and any other form of contamination inside the cabinet.
9. Check the voltage label on the back of the cabinet to ensure that it matches the voltage at the power outlet.
10. Check external power cables for damage.
11. Check correct closure of front and rear doors. Unlock the front door with the key, pull the handle forwards and upwards to disengage the lock.

2.6. Moving the Cabinet

The cabinet is equipped with four swivel castors so that it can be easily rolled to the location indicated on the Customer's floor plan.



CAUTION

If the cabinet is pre-equipped with servers and/or devices, two people are required to roll it to the required location.



Important If the cabinet is to be equipped with the Cool Door option, please refer to the *Cool Cabinet Door Installation and Service Guide 86A742FA* for more information on how the cabinet is to be positioned.

1. Check that the two front and four feet are raised and allow the cabinet to move freely.
2. Carefully guide the cabinet to its location.
3. Check required service clearance at the rear, front and sides of the cabinet.
4. Take care to leave sufficient access to raised floor cable cut-outs.

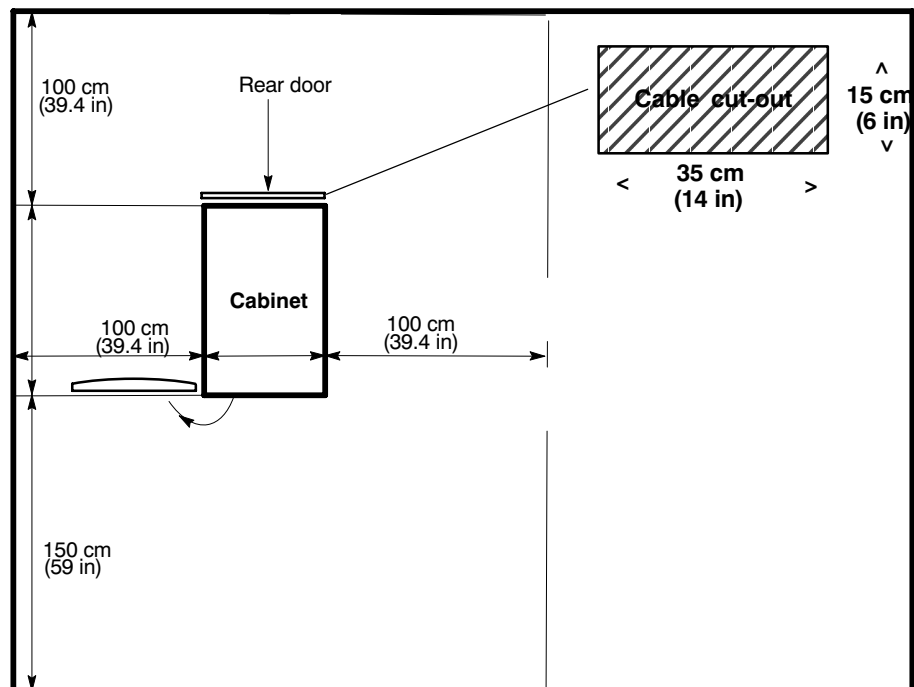

Figure 13. Cabinet service clearance

2.7. Securing the Cabinet

Once the cabinet has been correctly located, it must be secured into place by lowering feet and installing the stabilizer (optional).



DANGER

When equipped with servers and/or devices, the cabinet may be extremely heavy. It is mandatory for cabinet jacking screws to be locked safely into place and for the stabilizer to be installed before use or maintenance. Incorrect installation may result in serious personal injury or damage to components.

Lowering Feet

The jacking screws prevent the cabinet from rolling.

Tools Required

- None
1. Manually lower and lock the two front and four rear jacking screws into place.

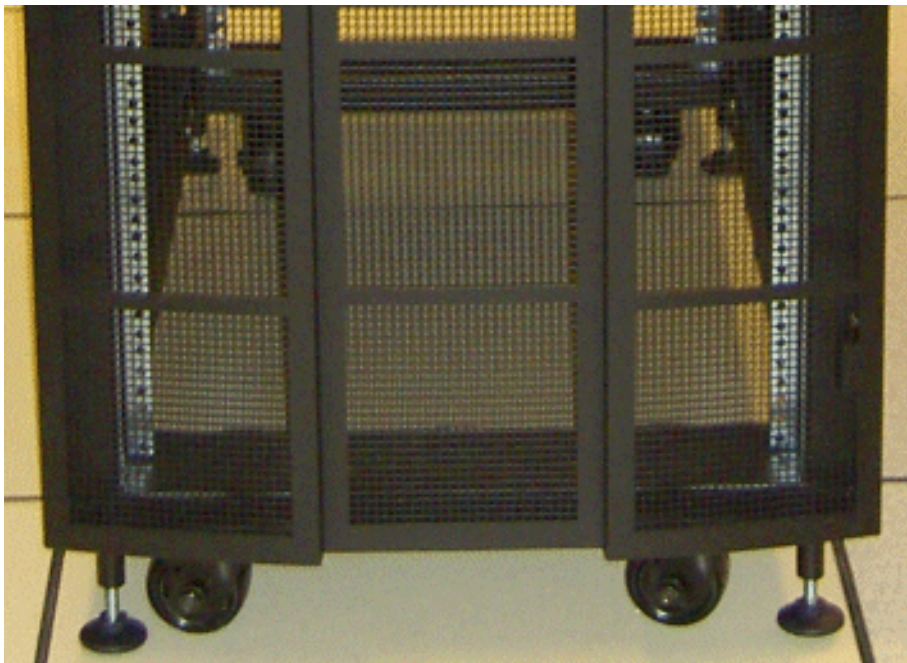

2. Lowering feet
3. Check cabinet stability.

2.8. Removing/Installing/Turning the Doors and Side Panels

For easy access, the front and rear doors and side panels can be removed when you install or remove servers and/or devices in the cabinet.

2.8.1. Removing the Front Door

Tools Required

- Door key

1. Unlock the door and pull the handle forwards and upwards to disengage the lock.
2. Open the door. The door is secured to the hinges with two door pins.
3. Remove the bottom door pin by pulling upwards and out of the hinge.
4. Remove the top door pin by pulling upwards and out of the hinge.



Figure 14. Removing the front door

5. Firmly grip either side of the door and lift away to remove from the hinges.
6. Store the door and door pins in a safe place.

2.8.2. Installing the Front Door

Tools Required

- Door key

1. Firmly grip either side of the front door and place at a right angle with the cabinet.
2. Line the door up with the hinges.
3. Carefully push the door onto the hinges.
4. Insert the top door pin by pushing downwards into the hinge
5. Insert the bottom door pin by pushing downwards into the hinge.

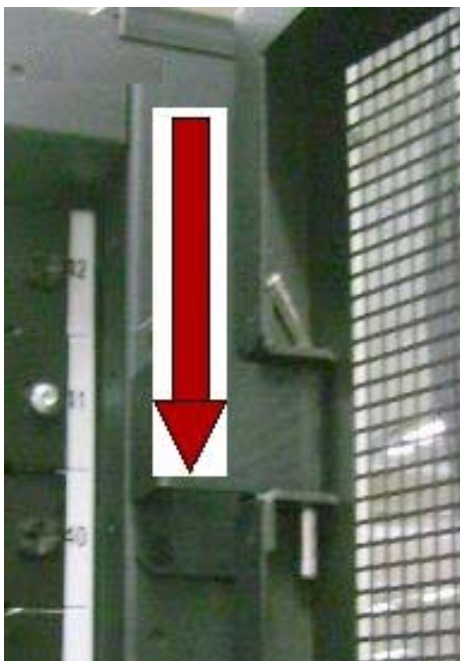

Figure 15. Installing the front door

6. Close the door and engage the lock by lowering the handle and pushing it back into the recess.
7. Lock the door with the key.

2.8.3. Removing the Rear Door

Procedure

1. Unlock the door and pull the handle forwards and upwards to disengage the lock.
2. Open the door.

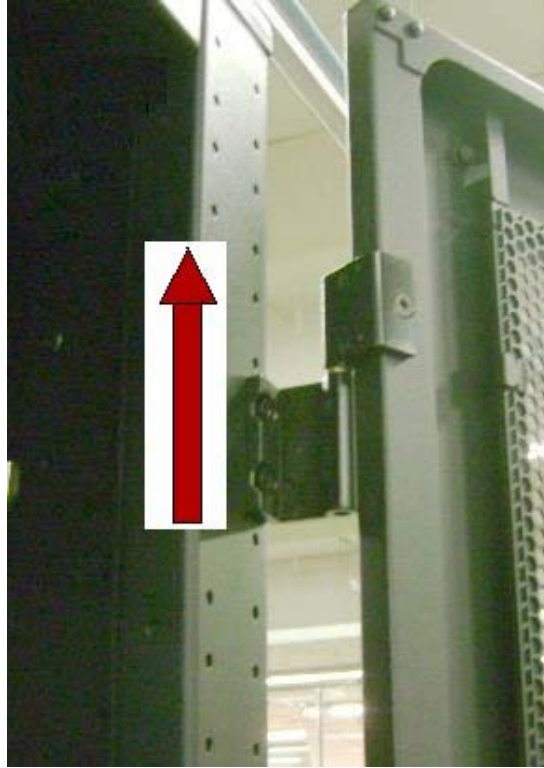

Figure 16. Removing the rear door

3. Firmly grip either side of the door and lift away to remove from the hinges.
4. Store the door in a safe place.

2.8.4. Installing the Rear Door

Tools Required

- Door key

1. Firmly grip either side of the front door and place at a right angle with the cabinet.
2. Line the door up with the hinges.
3. Carefully push the door onto the hinges.

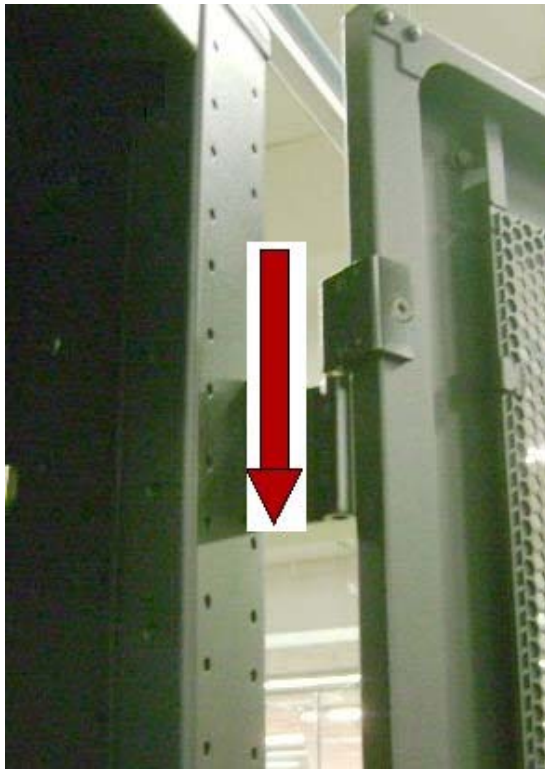

Figure 17. Installing the rear door

4. Close the door and engage the lock by lowering the handle and pushing it back into the recess.
5. Lock the door with the key.

2.8.5. Turning the Front/Rear Door

You can turn the front and/or rear door to change the opening direction to suit site configuration requirements.

Tools Required

- Screwdriver

1. Remove the door. See , on page 2-13 or , on page 2-15.
2. Turn the door up the other way.
3. Unscrew the locking bracket on the cabinet flange and screw back onto the opposite cabinet flange.

Note Rear door only:
Use the locking bracket provided in the box labeled *Open Me First*.

4. Unscrew the lock on the door, turn up the other way, and screw back into place.
5. Unscrew the locking mechanism, turn up the other way, and screw back into place on the other side of the lock.
6. Unscrew the logo, turn up the other way and screw back into place.
7. Refit the door. See , on page 2-14 or , on page 2-16 .

2.8.6. Removing a Side Panel

Tools Required

- Screwdriver

1. With the screwdriver, turn the two locks at the top of the side panel clockwise, taking care to hold the side panel in place.

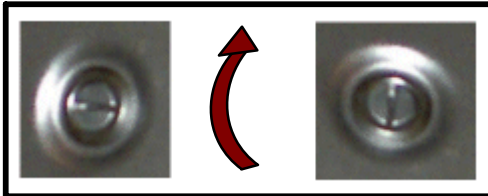

Figure 18. Opening side panel locks

2. Firmly grip either side of the side panel and lift carefully off the three lugs at the base of the cabinet.



Figure 19. Removing a side panel

3. Store the side panel in a safe place.

2.8.7. Installing a Side Panel

Tools Required

- Screwdriver

1. Firmly grip either side of the side panel and lift carefully onto the three lugs at the base of the cabinet.



Figure 20. Installing a side panel

2. With the screwdriver, turn the two locks at the top of the side panel anti-clockwise, taking care to hold the side panel in place.

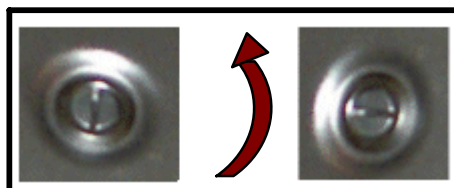

Figure 21. Closing side panel locks

3. Check that the side panel is secure.

2.9. Installing the Cool Cabinet Door

Installation of the Cool Cabinet Door is explained in *Cool Cabinet Door Installation and Service Guide 86A742FA* delivered with the door.

2.10. Installing Servers and Devices



Important You are requested to read the Safety Notices set out in the preface of this document before installing or servicing cabinets. The documentation delivered with rack-mountable servers and devices may contain important safety information. You are requested to carefully read the documentation delivered with servers and devices before installing them in the cabinet.



DANGER

- Feet must always be lowered.
- The stabilizer must always be installed when heavy equipment is loaded at the top of the cabinet.
- Servers and devices must always be fitted in the cabinet from the bottom upwards.
- Servers and devices must be fitted in the cabinet so that the air-flow is from front to back: all fans blowing towards the rear of the cabinet.
- The weight of servers and devices fitted in the cabinet must not exceed 20 kg (44 lbs) per U.
- Never slide more than one server or device out of the rack at a time.
- Thermal dissipation must not exceed 40 KW.
- Firmly secure servers and devices to the mounting flanges at the front and rear of the cabinet.
- Always use the mounting fixtures supplied with the servers and/or devices.

Checking Server/Device Compatibility

Before installing a server or device in the cabinet, you are advised to check and compare the internal dimensions of the cabinet with the external dimensions of the server / device and accessories (rail assembly, front bezel, handles, ...).

The following figure shows a top view of the cabinet and illustrates the dimensions to be taken into account before installing a server or device in the cabinet.

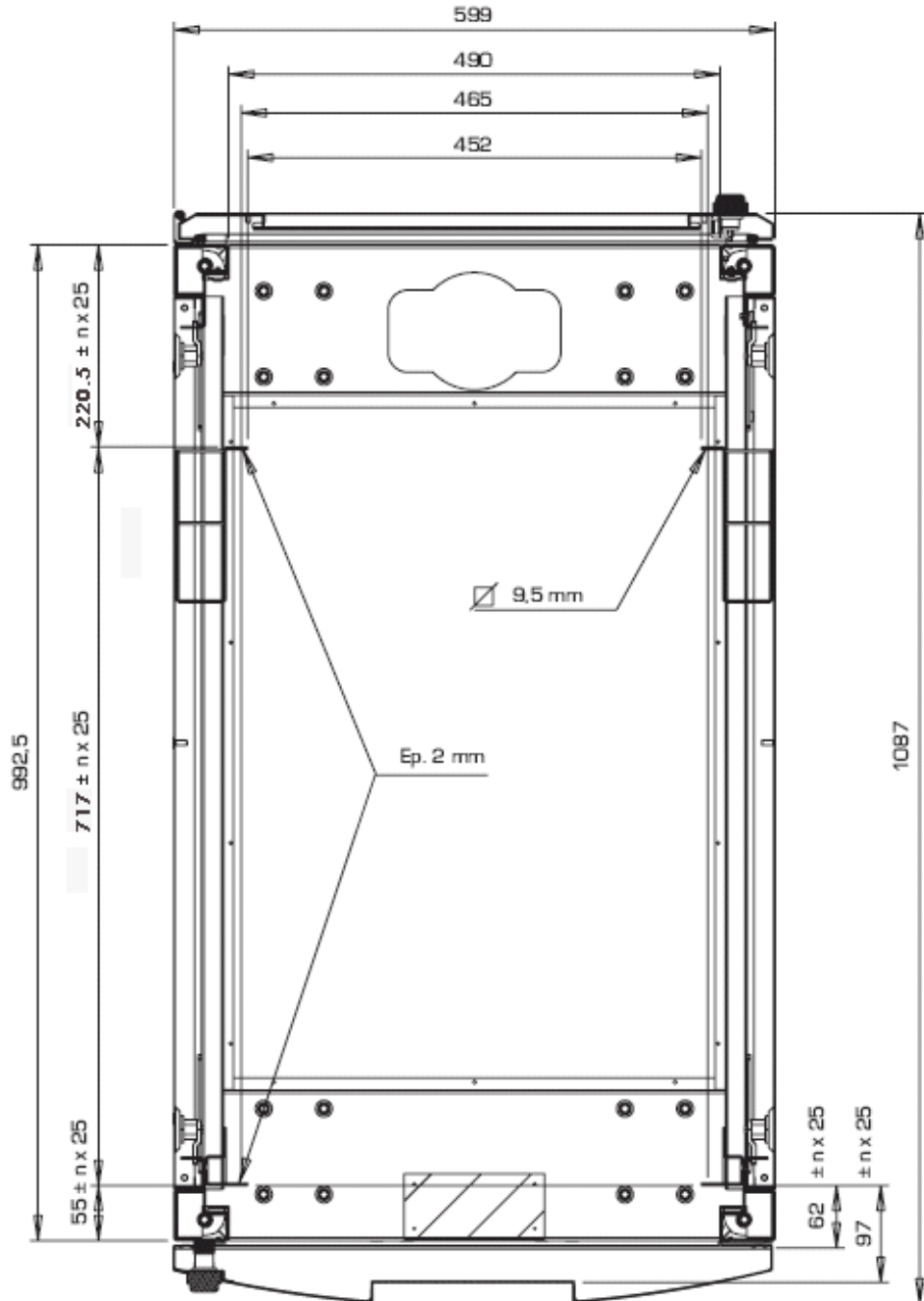

Figure 22. Internal cabinet dimensions

2.11. Fitting Equipment Trays

An equipment tray may be required to fit peripheral devices in cabinets.

Three equipment trays are available:

- Short Equipment Tray
- Medium Equipment Tray
- Long Equipment Tray



Important The documentation delivered with non-rackable peripheral devices may contain important safety information. You are requested to carefully read the documentation delivered with these devices before installing them on the equipment tray.

Mounting Flange Hole Size and Placement

Note 1 U = 44.45 mm (1.75 in)

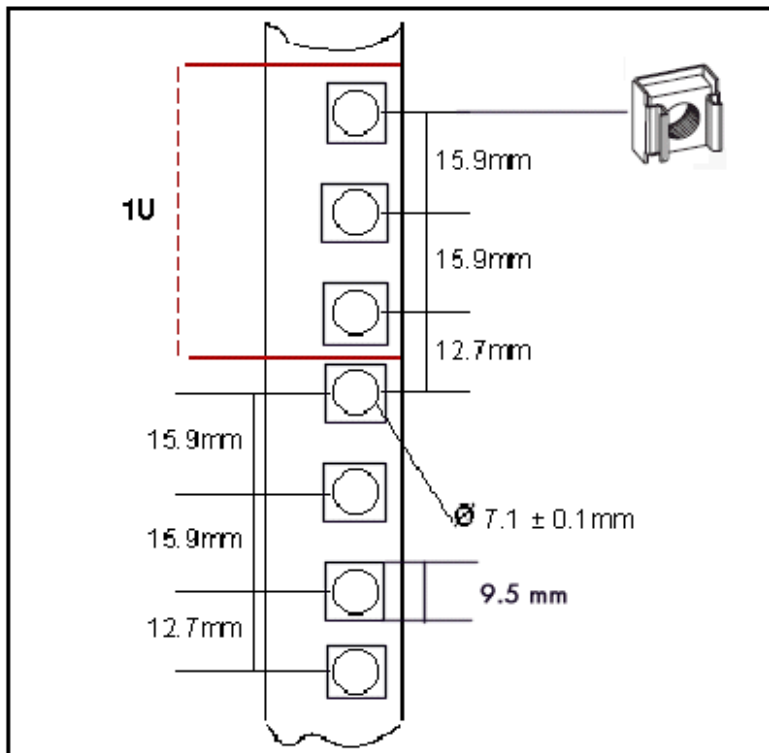



Figure 23. Mounting flange hole size and placement

2.12. Installing a PDU

Each PDU is delivered with mounting brackets for vertical and/or horizontal installation in the cabinet.

Note **Vertical Installation**
Up to six PDUs can be installed vertically in the cabinet flange space (3 right and 3 left).

 **Important** Before choosing a location for a PDU, check power cable length from the servers and devices you want to connect to the PDU. Before proceeding to install the PDU, check that the circuit breaker switch is OFF.

Tools Required

- Hex wrench
- PDU fixtures

Vertical Installation

1. Select the required location in the cabinet.
2. Install one cage nut (A) over the fixture holes at the top and bottom of the cabinet cut-out.

Horizontal Installation

1. Select the required location in the cabinet.
2. Install 2 cage nuts (A) over the required rack fixture holes on each side of the cabinet.

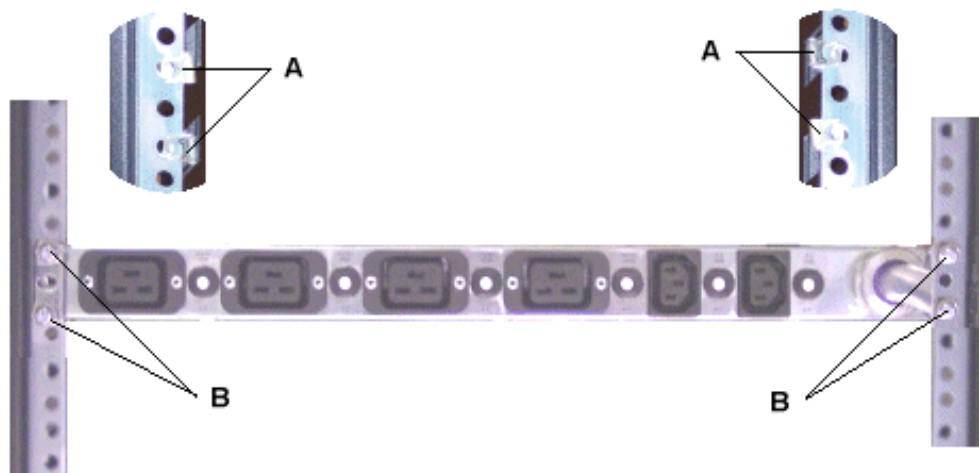

Figure 24. Installing a PDU horizontally

3. Align the PDU fixture holes with the rack fixture holes on the left and right sides of the cabinet.

4. Insert the bolt and washer assemblies in the top and bottom PDU fixture holes (B) and tighten with the hex wrench.

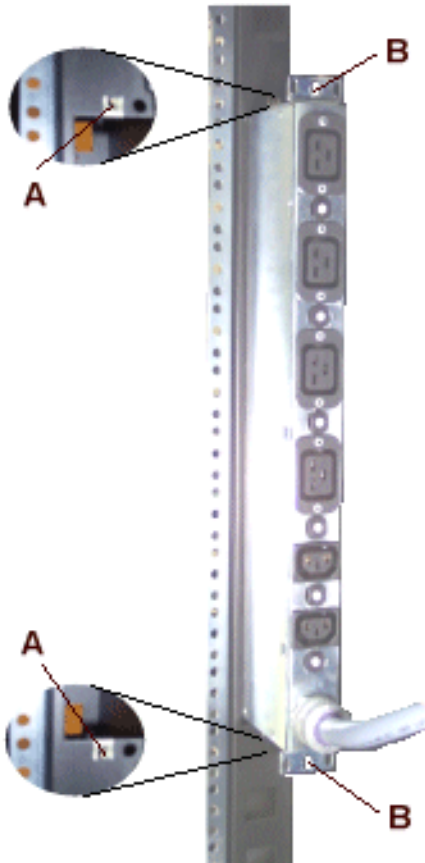

Figure 25. Installing a PDU vertically

5. Align the PDU with the cut-out in the cabinet flange and push firmly into place.
6. Insert the bolt and washer assemblies in the central PDU fixture holes (B) and tighten with the hex wrench.

Chapter 3. Managing Power and Data Cables

This chapter gives general recommendations for routing and connecting power and data cables inside the cabinet. It includes the following topics:

- Routing Data Cables, on page 3-1
- Connecting a PDU to the Site Power Supply, on page 3-2



Important

Please refer to the documentation delivered with your server and/or device for detailed cable management information.

3.1. Routing Data Cables

Please refer to the documentation delivered with your server and/or device for detailed cable management information.



Important

GENERAL RECOMMENDATIONS

- Label all cables for easy identification.
 - Secure cables with appropriate fixtures.
 - Ensure that cables are clear of doors and panels.
 - Take care not to route cables in front of other servers or devices.
 - When servers or devices are installed on slide rails:
Leave extra cable lengths for full mobility.
Route cables along cable arms and secure with appropriate fixtures.
 - Check that the PDU is compliant with server and/or device power requirements.
-

Routing Inter-Cabinet Data Cables



DANGER

Power cables must NEVER be routed between cabinets.



Important

Route inter-cabinet data cables through the cable openings at the rear of the cabinets.

3.2. Preparing a PDU for connection to the Site Power Supply

As required in the *Site Preparation Guide*, the Customer has provided the required power supply cables to the cable cut-outs at the base of the server.

The Customer is responsible for ensuring that the electrical network is compliant with the standards set out in the *Site Preparation Guide*.

PDU power cables are equipped with ready-mounted IEC60309 plugs. The Customer is responsible for supplying the appropriate IEC60309 sockets for connection to the site power supply. The following figure shows the provided plug and the appropriate socket.



Figure 26. Power plug and socket

Safety Recommendations



CAUTION

Only duly certified electricians may connect the PDU to the power supply, under the Customer's responsibility.



CAUTION

The PDU is equipped with three-wire power cables for user safety. Use these power cables with properly grounded electrical outlets to avoid electrical shock.



DANGER

An electrical outlet that is not correctly wired could place hazardous voltage on metal parts. It is the Customer's responsibility to ensure that the outlet is correctly wired and grounded to prevent an electrical shock.



DANGER

Use one hand, when possible, to connect or disconnect signal cables to prevent a possible shock from touching two surfaces with different electrical potentials.

Due to energy hazard, remove all jewelry before servicing.

Check that the dedicated power supply circuit breakers are OFF.

Mounting the PDU Power Cable Socket

For PDU/UPS equipped with IEC 60309 plugs.

1. Check that the power supply cable is not live with the multimeter.
2. Carefully guide the power supply cable through the cable inlet at the base of the cabinet.
3. Check that the power supply cable is long enough.
4. Unscrew the base of the socket (A), insert the cable through the socket base (B), and wire to the socket head, as shown in Figure 27 .



Figure 27. PDU/UPS Power socket

5. Screw the socket base back to the socket head (C).
6. Check for ≤ 0.1 ohm resistance between the grounding pin on the power cable plug and the metal frame with the multimeter.
7. Connect the power supply cable socket to the power cable plug.
8. Use velcro fasteners to secure the cable into place along the cabinet frame.

Appendix A. Specifications

This appendix gives detailed specifications for all cabinet and PDU models.

- R@ck'n Roll Cabinet Specifications, on page A-2
- R@ck-to-Build Cabinet Specifications, on page A-2
- PDU Common Electrical Specifications, on page A-3
- PDU 63A, 2xC13 - 4xC19, EU Specifications, on page A-4
- PDU 32A, 4xC13 - 2xC19, EU Specifications, on page A-4
- PDU 32A, 7xC13, EU Specifications, on page A-5
- PDU 32A, 12xC13, EU Specifications, on page A-5
- PDU 24A, 4xC13 - 2xC19, US Specifications, on page A-6

A.1. R@ck'n Roll Cabinet Specifications

Dimensions / Weight	
Unpacked	Packed
Height: 202 cm (80.0 in)	Height: 212 cm (83.5 in)
Width: 60.0 cm (23.6 in)	Width: 80.0 cm (31.5 in)
Depth: 111.5 cm (43.9 in)	Depth: 122.0 cm (55.1 in)
Weight (empty): 135 kg (298 lb)	Weight (empty): 165 kg (364 lb)
Weight (full max.): 935 kg (2062 lb)	Weight (full max.): 965 kg (2128 lb)
Maximum load: 800 kg (1764 lb)	
Service Clearance	
Front	150 cm
Rear	100 cm
Side (left and right)	100 cm
Shipping Limits (NF ISO 2233)	
Temperature: 20°C	
Relative Humidity: 65%	

Table 1. R@ck'n Roll Cabinet Specifications

A.2. R@ck-to-Build Cabinet Specifications

Dimensions / Weight	
Unpacked	Packed
Height: 202 cm (80.0 in)	Height: 212 cm (83.5 in)
Width: 60.0 cm (23.6 in)	Width: 80.0 cm (31.5 in)
Depth: 111.5 cm (43.9 in)	Depth: 122.0 cm (55.1 in)
Weight (empty): 135 kg (298 lb)	Weight (empty): 165 kg (364 lb)
Weight (full max.): 935 kg (2062 lb)	Weight (full max.): 965 kg (2128 lb)
Maximum load: 800 kg (1764 lb)	
Service Clearance	
Front	150 cm
Rear	100 cm
Side (left and right)	100 cm
Shipping Limits (NF ISO 2233)	
Temperature: 20°C	
Relative Humidity: 65%	

Table 2. R@ck-to-Build Cabinet Specifications

A.3. PDU Common Electrical Specifications

Notes It is mandatory for power lines and terminal boxes to be located within the immediate vicinity of the system and to be easily accessible.
 Each power line must be connected to a separate, independent electrical panel and bipolar circuit breaker.
 France:
 Power sockets and plugs must be compliant with Decree 88-1056 Article 20-IV, dated 14th November 1988.

Europe	
Nominal voltage	230 VAC (Phase / Neutral)
Voltage range	207 - 244 VAC
Frequency	50 Hz \pm 1%
North America	
Nominal voltage	208 VAC (Phase / Neutral)
Voltage range	200 - 240 VAC
Frequency	60 Hz \pm 0.3%
Japan	
Nominal voltage	200 VAC (Phase / Neutral)
Voltage range	188 - 212 VAC
Frequency	60 Hz \pm 0.2%
Brazil	
Nominal voltage	230 VAC (Phase / Neutral)
Voltage range	207 - 244 VAC
Frequency	50 Hz \pm 1%

Table 3. PDU common specifications

A.4. PDU 63A, 2xC13 - 4xC19, EU Specifications

Dimensions/Weight	
Height	4.1 cm (1.6 in)
Width	48.3 cm (19 in)
Depth	12 cm (4.7 in)
Weight	2 kg (4.4 lb)
Outlets	
14.5A (C19)	4
9A (C13)	2
Power Cables	
AC (63A)	1 per PDU
Mains cable type	3 x AWG06
Mains plug type	IEC60309-63A
Mains socket type	IEC60309-63A
Breaker Protection	
Maximum current	63A
Maximum voltage	250 VAC

Table 4. PDU 63A, 2xC13 - 4xC19, EU specifications

A.5. PDU 32A, 4xC13 - 2xC19, EU Specifications

Dimensions/Weight	
Height	4.1 cm (1.6 in)
Width	48.3 cm (19 in)
Depth	12 cm (4.7 in)
Weight	2 kg (4.4 lb)
Outlets	
14.5A (C19)	2
9A (C13)	4
Power Cables	
AC (63A)	1 per PDU
Mains cable type	3 x AWG10
Mains plug type	IEC60309-63A
Mains socket type	IEC60309-32A
Breaker Protection	
Maximum current	32A
Maximum voltage	250 VAC

Table 5. PDU 32A, 4xC13 - 2xC19, EU specifications

A.6. PDU 32A, 7xC13, EU Specifications

Dimensions/Weight	
Height	4.35 cm (1.7 in)
Width	48.3 cm (19 in)
Depth	12 cm (4.7 in)
Weight	2 kg (4.4 lb)
Outlets	
14.5A (C19)	0
9A (C13)	7
Power Cables	
AC (63A)	1 per PDU
Mains cable type	3 x AWG10
Mains plug type	IEC60309-32A
Mains socket type	IEC60309-32A
Breaker Protection	
Maximum current	32A
Maximum voltage	250 VAC

Table 6. PDU 32A, 7xC13, EU specifications

A.7. PDU 32A, 12xC13, EU Specifications

Dimensions/Weight	
Height	4.1 cm (1.6 in)
Width	48.3 cm (19 in)
Depth	12 cm (4.7 in)
Weight	2 kg (4.4 lb)
Outlets	
14.5A (C19)	0
9A (C13)	12
Power Cables	
AC (63A)	1 per PDU
Mains cable type	3 x AWG10
Mains plug type	IEC60309-32A
Mains socket type	IEC60309-32A
Breaker Protection	
Maximum current	32A
Maximum voltage	250 VAC

Table 7. PDU 32A, 12xC13, EU specifications

A.8. PDU 24A, 4xC13 - 2xC19, US Specifications

Dimensions/Weight	
Height	4.1 cm (1.6 in)
Width	48.3 cm (19 in)
Depth	12 cm (4.7 in)
Weight	2 kg (4.4 lb)
Outlets	
16A (C19)	2
8A (C13)	4
Power Cables	
AC (24A)	1 per PDU
Mains cable type	3 x AWG10
Mains plug type	IEC60309-32A
Mains socket type	IEC60309-32A
Breaker Protection	
Maximum current	24A
Maximum voltage	125 VAC

Table 8. PDU 24A, 4xC13 - 2xC19, US specifications

Index

C

Cabinet

- inspecting, 2-10
- jacking screws, 2-12
- models, 1-2
- moving, 2-11
- packing, 2-3
- relocating, 2-11
- securing, 2-12
- service clearance, 2-8
- specifications, A-1
- unloading, 2-8

Cables

- data, 3-1
- inter-cabinet, 3-1

Compatibility, server / device, 2-21

Connecting, PDU, 3-2

D

Data, cables, 3-1

Data cables, routing, 3-1

Devices, installing, 2-20

Doors, turning, 2-17

E

Electrical safety, xi

Equipment tray, fitting, 2-22

F

Flange hole, size, 2-21

Front door

- installing, 2-13, 2-14
- removing, 2-13

I

Installing

- a side panel, 2-19
- devices, 2-20
- PDU, 2-23
- servers, 2-20
- the front door, 2-14
- the rear door, 2-16

Inter-cabinet cables, routing, 3-1

J

Jacking screws, lowering, 2-12

L

Labels, shockwatch, 2-3

Laser safety, xi

M

Models

- cabinet, 1-2
- PDU, 1-3

Mounting, PDU Power Cable, 3-3

N

Notices

- electrical safety, xi
- laser safety, xi
- safety, x

P

Packing

- cabinet, 2-3
- storing, 2-7

Packing items

- removing, 2-6
- storing, 2-6

PDU

- connecting, 3-2
- installing, 2-23
- models, 1-3
- Mounting Power Cable Socket, 3-3
- specifications, A-1

PDU model

- PDU 24A 4x C13 2x C19 US, 1-5
- PDU 32A 12x C13 EU, 1-8
- PDU- 63A 2x C13 4x C19 EU, 1-6

PDU models, PDU 32A 7x C13 EU, 1-7

Power supply, connecting a PDU, 3-2

R

Rear door

- installing, 2-13, 2-16
- removing, 2-13, 2-15

Relocating, cabinet, 2-11

Removing

- side panel, 2-18
- the front door, 2-13
- the rear door, 2-15

Routing

- data cables, 3-1
- inter-cabinet cables, 3-1

S

Safety

- notices, x
- recommendations, 3-2

Server / Device, compatibility, 2-21

Servers, installing, 2-20

Service clearance, cabinet, 2-8

Shockwatch, labels, 2-3

Side Panel

- installing, 2-19
- removing, 2-18

Specifications

- cabinet, A-1
- PDU, A-1

T

Turning, doors, 2-17

U

Unloading, cabinet, 2-8

Bull Cedoc
357 avenue Patton
BP 20845
49008 Angers Cedex 01
FRANCE

REFERENCE
86 A1 17FA 01