

**EVIDEN**

BullSequana EXR & AI100R

# **Description Guide**

The following copyright notice protects this book under Copyright laws which prohibit such actions as, but not limited to, copying, distributing, modifying, and making derivative works.

Copyright ©Bull SAS 2024, part of Eviden group. Eviden is a registered trademark of Eviden SAS. This document, or any part of it, may not be reproduced, copied, circulated and/or distributed nor quoted without prior written approval from Bull SAS.

## **Trademarks and Acknowledgments**

We acknowledge the right of proprietors of trademarks mentioned in this manual.

All brand names and software and hardware product names are subject to trademark and/or patent protection.

Quoting of brand and product names is for information purposes only and does not represent trademark and/or patent misuse.

### **Hardware**

**November 2024**

**Eviden  
30 bis rue du Nid de Pie  
49000 Angers  
FRANCE**

The information in this document is subject to change without notice. Eviden will not be liable for errors contained herein, or for incidental or consequential damages in connection with the use of this material.

---

# Table of contents

<b>Preface</b> .....	<b>p-1</b>
Intended readers .....	p-1
Important user information .....	p-1
<b>Regulatory declarations and disclaimers</b> .....	<b>p-2</b>
Safety compliance statement .....	p-2
European Union (EU) .....	p-2
UL/CSA certification .....	p-2
Electromagnetic compatibility statement .....	p-2
European Union (EU) .....	p-2
Federal Communications Commission (FCC) compliance (USA) .....	p-2
ICES-003 compliance (Canada) .....	p-3
Waste management .....	p-3
REACH .....	p-3
ROHS .....	p-3
WEEE .....	p-3
<b>Safety notices</b> .....	<b>p-4</b>
<b>Chapter 1. Related publications</b> .....	<b>1-1</b>
<b>Chapter 2. BullSequana EXR &amp; AI100R description</b> .....	<b>2-1</b>
2.1. Overview .....	2-1
2.2. Front components .....	2-2
2.2.1. 2.5 inch SATA disk option .....	2-2
2.2.2. M.2 NVMe disk option .....	2-2
2.3. Rear components .....	2-3
2.4. Top level components .....	2-4
2.4.1. 2.5 inch SATA disk option .....	2-4
2.4.2. M.2 NVMe disk option .....	2-5
2.5. Base level components .....	2-6
2.5.1. Components .....	2-6
2.5.2. Memory modules .....	2-7
2.5.3. Fans .....	2-8
2.5.4. M.2 riser board .....	2-9
2.6. Storage .....	2-11
2.6.1. 2.5 inch SATA disk option .....	2-11
2.6.2. M.2 NVMe disk option .....	2-13
<b>Chapter 3. Buttons, ports and LEDs</b> .....	<b>3-1</b>
3.1. Front buttons, ports and LEDs .....	3-1

3.1.1.	2.5 inch SATA disk option .....	3-1
3.1.2.	M.2 NVMe disk option .....	3-4
3.2.	Rear buttons, ports and LEDs .....	3-7
3.2.1.	Buttons .....	3-7
3.2.2.	Ports .....	3-7
3.2.3.	LEDs .....	3-9
<b>Appendix A.</b>	<b>Technical description .....</b>	<b>A-1</b>
A.1.	General technical specifications .....	A-1
A.2.	Dimensions and weight .....	A-2
A.3.	Module technical specifications .....	A-3
A.4.	Server technical description .....	A-4
A.5.	Antenna specifications .....	A-5
A.5.1.	Dual-band WiFi .....	A-5
A.5.2.	LoraWAN .....	A-6
A.5.3.	LTE / 5G .....	A-7
<b>Acronyms</b>	.....	<b>a-1</b>

---

## Preface

This guide provides a general overview of the server.

---

**See** The Bull support web site for the most up-to-date product information, documentation, firmware updates, software fixes and service offers:  
<https://support.bull.com>

---

---

## Intended readers

This guide is intended for use by system administrators and operators.

---

## Important user information

Read this document and the other product documents about installation, configuration, operation, and maintenance of the product before installing, configuring, operating or servicing it.

Activities including installation, adjustments, putting into service, use, and maintenance are required to be carried out by suitably trained personnel in accordance with applicable codes of practice.

If the product is used in a manner not specified by the manufacturer, the protection provided by the product may be impaired.



**DANGER D049**

**The product must not be used in life support system or other applications where failure could threaten injury or life, and any such use voids the limited warranty associated to the product.**

---

## Regulatory declarations and disclaimers

---

### Safety compliance statement

This product is in compliance with the following:

#### European Union (EU)

Low voltage directive 2014/35/EU: standard EN 62368-1

#### UL/CSA certification

UL 62368 (USA)

CSA 62368 (Canada)

---

### Electromagnetic compatibility statement

This product is in compliance with the protection requirements of the following:

#### European Union (EU)

EMC directive 2014/30/EU : standards EN 55032, EN 55035, EN 61000-3-2, EN 61000-3-3

#### Federal Communications Commission (FCC) compliance (USA)

CFR 47, FCC Part 15 B

#### FCC declaration of conformity

This device complies with Part 15 of the FCC Rules. Operation is subject to the following two conditions: (1) this device may not cause harmful interference, and (2) this device must accept any interference received, including interference that may cause undesired operation.

#### FCC statement

This equipment has been tested and found to comply with the limits for a Class A digital device, pursuant to Part 15 of the FCC Rules. These limits are designed to provide reasonable protection against harmful interference when the equipment is operated in a commercial environment. This equipment generates, uses, and can radiate radio frequency energy and, if not installed and used in accordance with the instruction manual, may cause harmful interference to radio communications. Operation of this equipment in a residential area is likely to cause harmful interference in which case the user will be required to correct the interference at his own expense.

Properly shielded and grounded cables and connectors must be used in order to meet FCC emission limits. Neither the provider nor the manufacturer are responsible for any radio or television interference caused by using other than recommended cables and connectors or by unauthorized changes or modifications to this equipment. Unauthorized changes or modifications could void the user's authority to operate the equipment.

Pursuant to Part 15.21 of the FCC Rules, any changes or modifications to this equipment not expressly approved by the manufacturer may cause harmful interference and void the FCC authorization to operate this equipment. An FCC regulatory label is affixed to the equipment.

### **ICES-003 compliance (Canada)**

Canadian Compliance Statement (Industry Canada)

This Class A digital apparatus meets all requirements of the Canadian Interference Causing Equipment Regulations.

This product is in conformity with the protection requirements of the ICES-003 standard.

---

## **Waste management**

This product has been built to comply with the following:

### **REACH**

Regulation (EC) N°1907/2006 of the European Parliament and the 18/12/2006 REACH Council

### **ROHS**

2011/65/EU, complemented by the delegated directive 2015/863/UE

### **WEEE**

2012/19/EU

---

## Safety notices

---

**Important**    **Read the safety notices before undertaking any procedures described in the documentation.**

---

All safety notices used in the documentation are listed in the Multilingual Safety Notices Guide and are classified by severity:



**DANGER D000**

**A Danger notice indicates the presence of a hazard that has the potential of causing death or serious personal injury.**



**CAUTION C000**

**A Caution notice indicates the presence of a hazard that has the potential of causing moderate or minor personal injury.**



**WARNING W000**

**A Warning notice indicates an action that could cause damage to a program, device, system, or data.**

Each safety notices is prefixed with a unique identification number. This can be used to locate the corresponding translated version in the Multilingual Safety Notices Guide.



---

# Chapter 1. Related publications

This list is not exhaustive. Useful documentation is supplied on the Resource and Documentation ISO file delivered with the system. It is strongly advised to refer carefully to this documentation before proceeding to configure, use, maintain, or update the system.

## Documentation Sets

- BullSequana EX & AI Customer Documentation Set, 86 XP 74PA  
This documentation set contains all the customer documentation relative to the server.
- BullSequana EX & AI Field Documentation Set, 86 XP 75PA  
This documentation set contains all the field documentation relative to the server.

## Read me First

- Resource and Documentation ISO file  
This ISO file contains the tools and documentation required to configure, operate and maintain the system.
- BullSequana Servers Site Preparation Guide, 86 A1 85FP  
This guide explains how to prepare a data processing center for servers, in compliance with the standards in force. This guide is intended for use by all personnel and trade representatives involved in the site preparation process.
- BullSequana Servers Safety Notices Guide, 86 X1 12FL  
This guide lists, in different languages, the notices referenced in the documentation procedures.
- BullSequana EXR & AI100R Description Guide, 86 A1 73FS  
This guide provides a general overview of the server. This guide is intended for use by system administrators and operators.

## Installation

BullSequana EXR & AI100R Installation Guide, 86 A1 76FS

This guide explains how to install the server for the first time. This guide is intended for use by instructed or skilled personnel in charge of installing the server.

## Operation

- BullSequana EX & AI Server Hardware Console (SHC), 86 A1 26FT  
This guide explains how to use the SHC to manage the server. This guide is intended for use by system administrators and operators.

- BullSequana Servers MONGUI User's Guide, 86 A1 61FT  
 This guide explains how to use the MONitoring Graphical User Interface (MONGUI) to manage BullSequana servers.
- BullSequana EX & AI Getting Started Guide, 86 A1 31FT  
 This guide explains how to set up the server. This guide is intended for use by system administrators and operators.
- BullSequana EX & AI Redfish Documentation, 86 A1 38FT  
 This guide explains the implementation of the Redfish API for server management. This guide is intended for use by system administrators and operators.
- BullSequana Servers OneBSM Console Reference Guide, 86 A1 55FT  
 This guide explains how to use the OneBSM console to monitor and maintain Eviden systems. This guide is intended for use by system administrators and operators.

## **Maintenance**

- BullSequana EX & AI Redfish Events Messages, 86 A1 35FT  
 This guide lists the messages issued by the server and provides associated actions and information to troubleshoot. This guide is intended for use by system administrators and operators.
- BullSequana EXR & AI100R Customer Service Guide, 86 A1 34FT  
 This guide explains how to replace the Customer Replaceable Units (CRUs) of the server. This guide is intended for use by instructed or skilled personnel in charge of server and cabinet maintenance.
- BullSequana EXR & AI100R Field Service Guide, 86 A7 47FT  
 This guide explains how to replace the Field Replaceable Units (FRUs) of a server. This guide is intended for use by instructed or skilled personnel in charge of server and cabinet maintenance.

---

## Chapter 2. BullSequana EXR & AI100R description

---

### 2.1. Overview

BullSequana EX & AI servers exploit the Intel® Xeon® platform, Sapphire Rapids processor. Each BullSequana EX & AI includes one processor that can support up to eight DDR5 memory modules.

Each BullSequana EXR & AI100R module is 1U high.

Two storage options are available:

- Up to 6 front loaded hot swappable 2.5 inch SATA disk modules
- Up to 8x M.2 NVMe disks are available for storage

In addition two M.2 cards are supported on an internal riser for boot disk, accelerator cards and WIFI communication card options.

A PCIe module supports one double or two single width PCIe cards, including GPU accelerators.

Four wireless technologies are supported:

- 2.4 GHz - 5.9 GHz dual-band WiFi (Dual-band WiFi)
- Bluetooth
- Long Term Evolution 5G Global System for Mobile Communications
- LoRa

BullSequana EX & AI servers are air-cooled and managed by a single Baseboard Management Controller (BMC).

## 2.2. Front components

### 2.2.1. 2.5 inch SATA disk option

 Front view

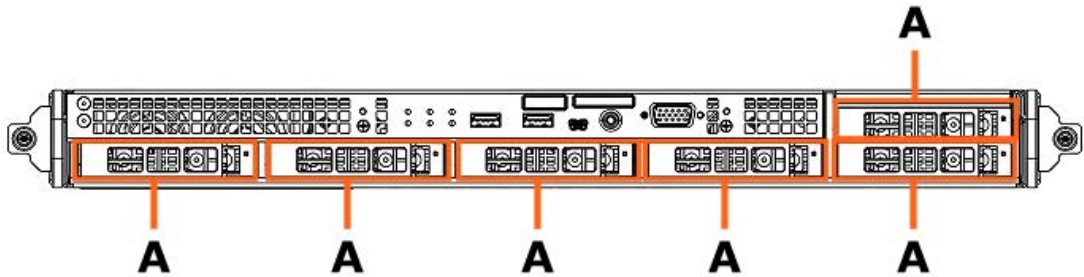

Mark	Description	Quantity
A	2.5 inch SATA disks	6

### 2.2.2. M.2 NVMe disk option

There are no accessible components at the front of the server.

 Front view

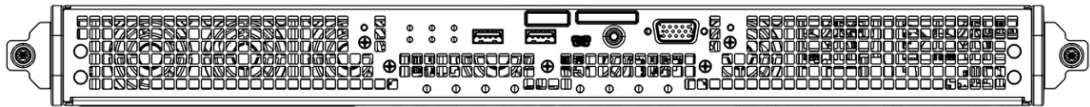

## 2.3. Rear components

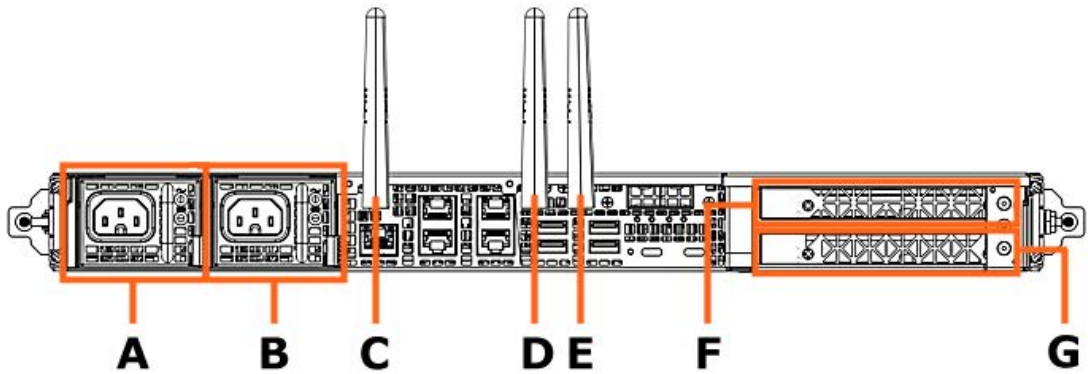

Mark	Description
A	PSU 0
B	PSU 1
C	Antenna
D	Antenna
E	Antenna
F	Up to 2 x 150 W or 1 x 300 W PCIe modules
G	

### Notes

- The server is equipped with two PSUs (2N redundancy).
- Dual-band 2.4-5.9 GHz WIFI, LoRa, LTE/5G wireless technologies are supported. See the Installation Guide for the different antenna configurations possible.

## 2.4. Top level components

### 2.4.1. 2.5 inch SATA disk option

 Top view

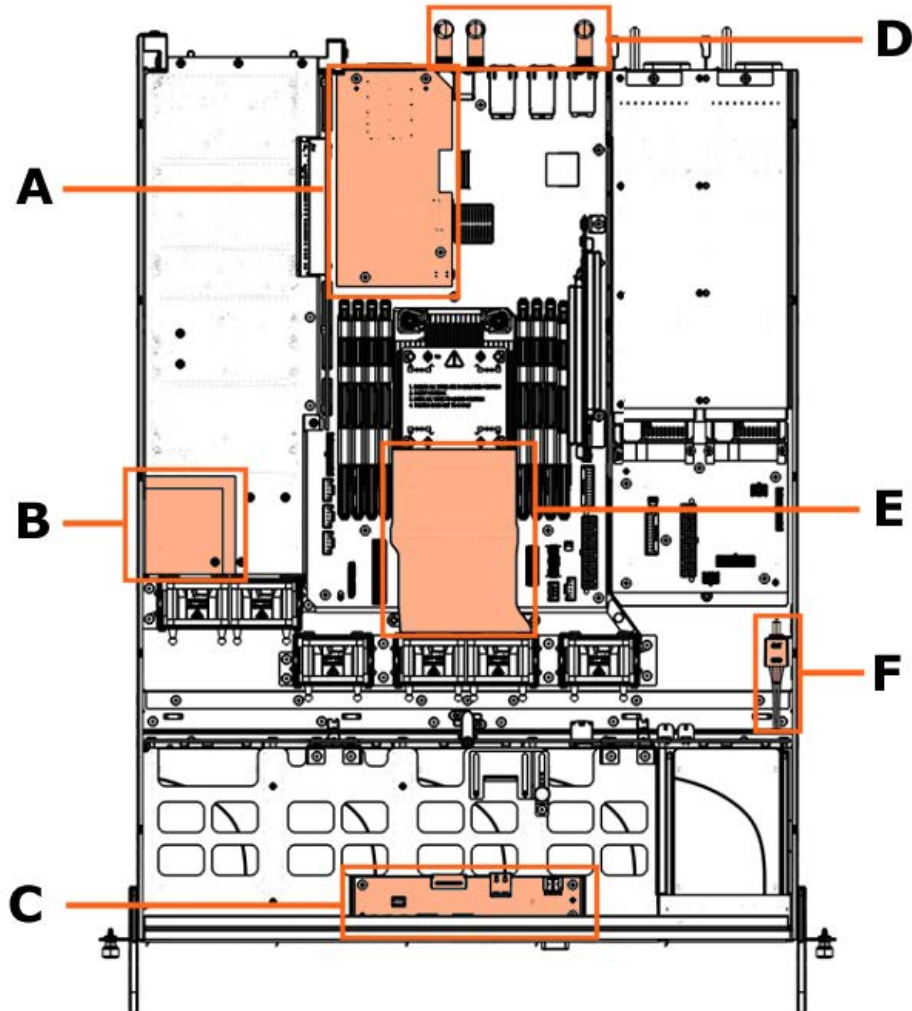

Mark	Description	Quantity
A	10 Gb/s mezzanine (optional)	1
B	PCIe air duct	1
C	Front Panel Board (FPB)	1
D	Antennas	Up to 3
E	Processor air duct	1
F	Intrusion detection switch	1

## 2.4.2. M.2 NVMe disk option

 Top view

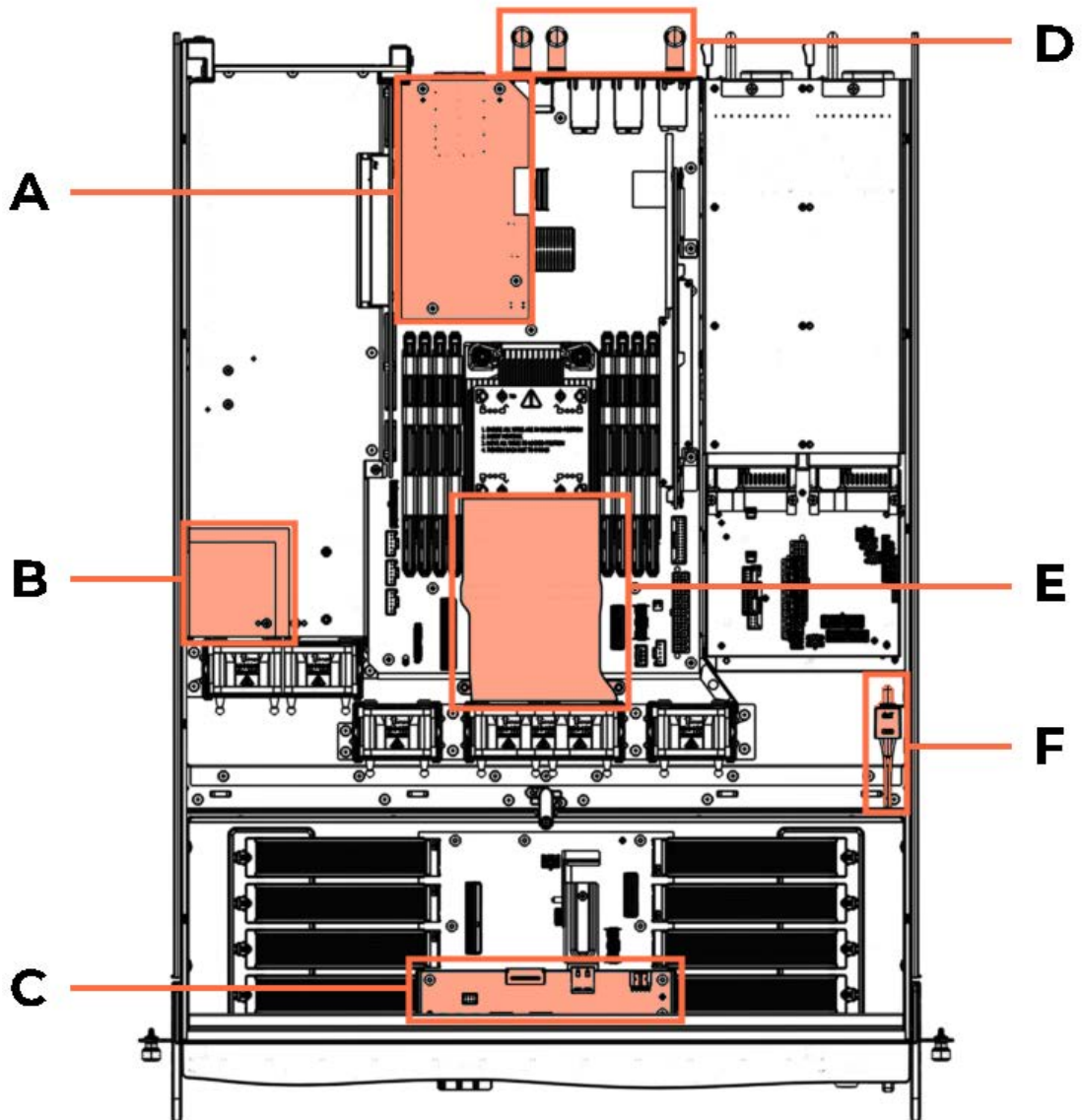

Mark	Description	Quantity
A	10 Gb/s mezzanine (optional)	1
B	PCIe air duct	1
C	Front Panel Board (FPB)	1
D	Antennas	Up to 3
E	Processor air duct	1
F	Intrusion detection switch	1

## 2.5. Base level components

### 2.5.1. Components

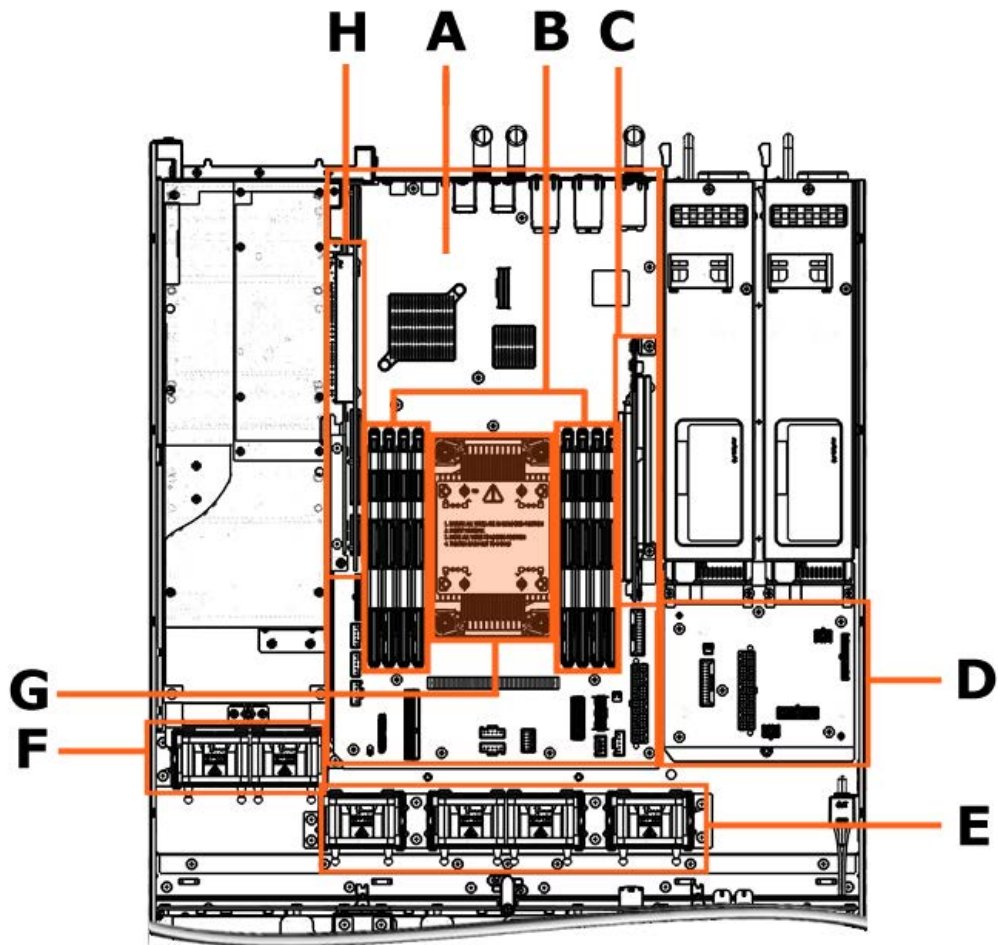

Mark	Description	Quantity
A	Motherboard	1
B	Memory modules	8
C	M.2 riser board	1
D	Power Distribution Board (PDB)	1
E	Motherboard fans	4
F	PCIe fans	2
G	Processor assembly	1
H	PCIe riser board	1



## 2.5.2. Memory modules

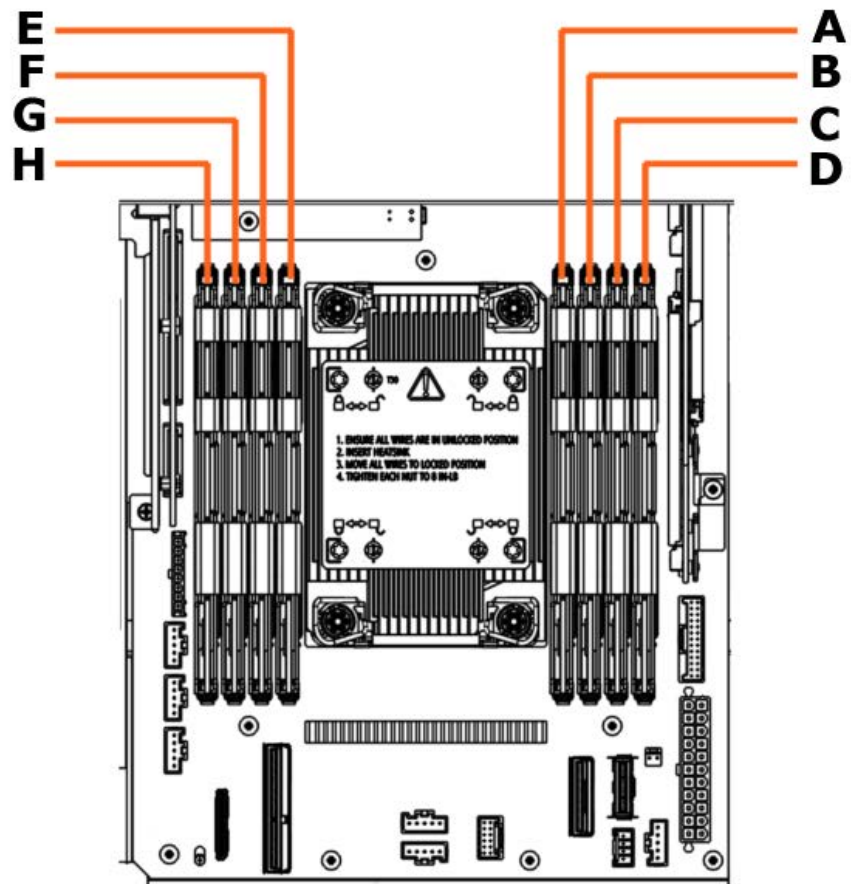

Mark	Channel Number	Board slot
A	0	CH-A
B	1	CH-B
C	2	CH-C
D	3	CH-D
E	4	CH-E
F	5	CH-F
G	6	CH-G
H	7	CH-H

### 2.5.3. Fans

 Top view

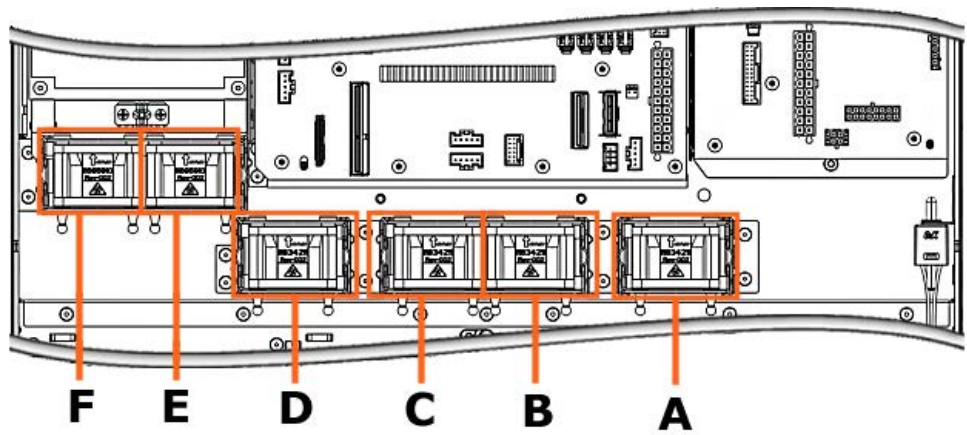

Mark	Description		
A	Motherboard fans	Single fan	FAN 0
B		Processor fans	FAN 1
C			FAN 2
D		Single fan	FAN 3
E	PCIe fans		FAN 4
F			FAN 5

## 2.5.4. M.2 riser board

### M.2 type M riser board

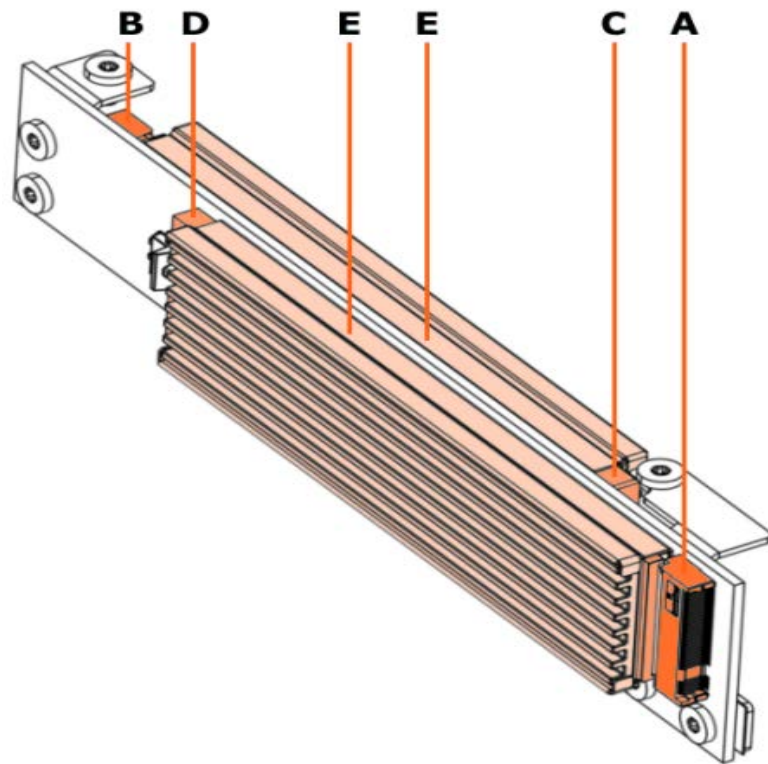

Mark	Slot	Possible card type
A	Slot 0 - M key connector	<ul style="list-style-type: none"> <li>▪ M.2 NVMe disk - M key (C)</li> <li>▪ Accelerator card - B+M key (C)</li> </ul>
B	Slot 1 - M key connector	<ul style="list-style-type: none"> <li>▪ M.2 NVMe disk - M key (C)</li> <li>▪ Accelerator card - B+M key (C)</li> </ul>
E	M.2 heat sink	N/A

### Possible configurations

Slot	Configuration 1	Configuration 2	Configuration 3
M key connector	M.2 NVMe disk M key	Accelerator card B+M key	Accelerator card B+M key
M key connector	M.2 NVMe disk M key	Accelerator card B+M key	M.2 NVMe disk M key

## M.2 type B riser board

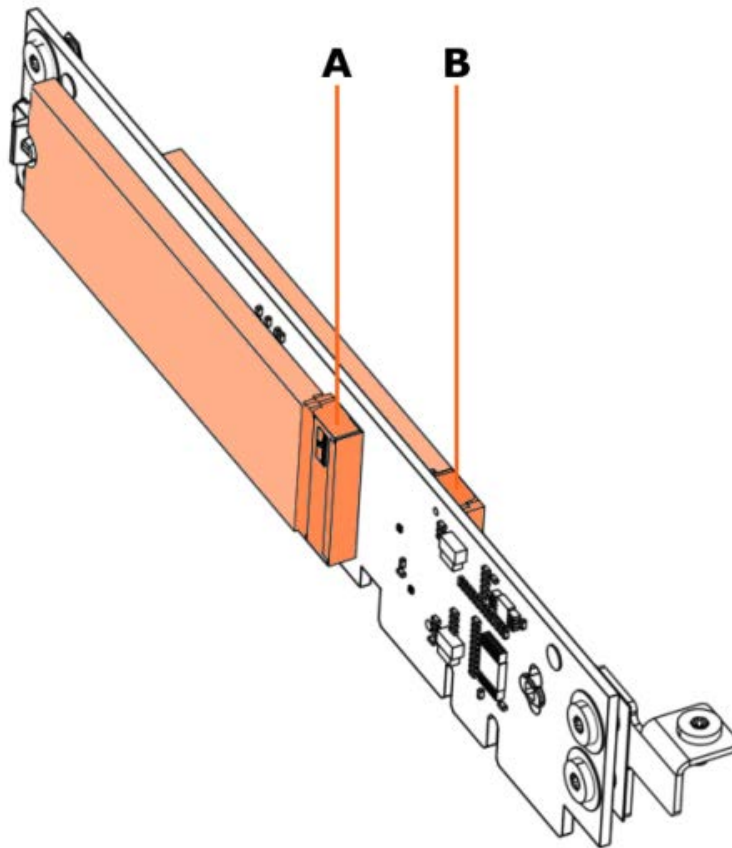

Mark	Slot	Possible card types
A	Slot 0 - B key connector	<ul style="list-style-type: none"> <li>▪ LTE 5G</li> <li>▪ Accelerator - B+M key</li> </ul>
B	Slot 1 - E key connector	<ul style="list-style-type: none"> <li>▪ LoRa (using adaptor)</li> <li>▪ WIFI + Bluetooth</li> <li>▪ Accelerator - A+E key</li> </ul>

### Possible configurations

Slot	Config 1	Config 2	Config 3	Config 4	Config 5
B key connector	LTE\5G	Accelerator card B+M key	LTE\5G	LTE\5G	Accelerator card B+M key
E key connector	WIFI + Bluetooth	WIFI + Bluetooth	Accelerator card A+E key	LoRa	LoRa

## 2.6. Storage

### 2.6.1. 2.5 inch SATA disk option

 Top view

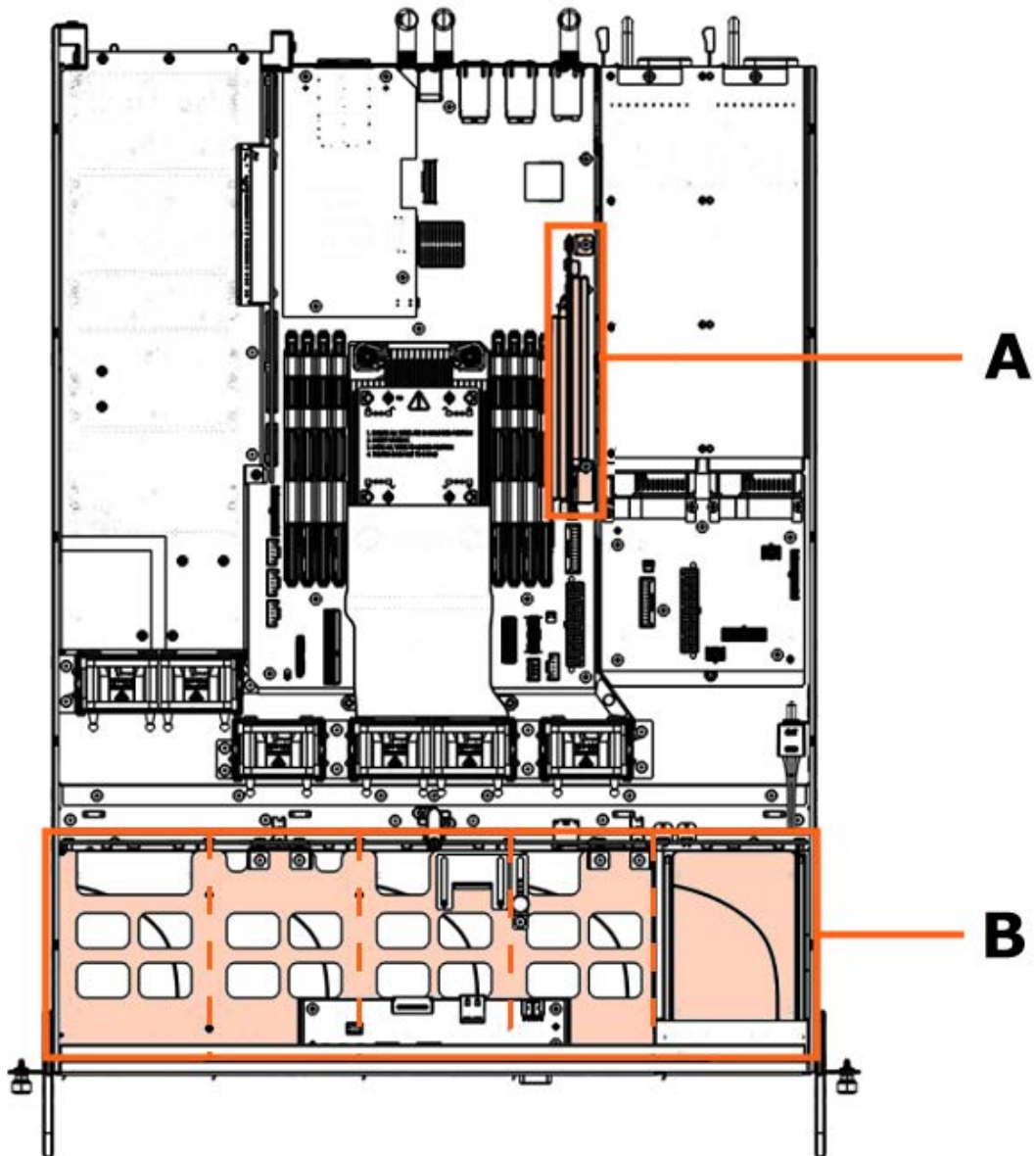

Mark	Description	Quantity
A	M.2 NVMe disks	2
B	2.5 inch SATA disks	6

## 2.5 inch SATA disk numbering

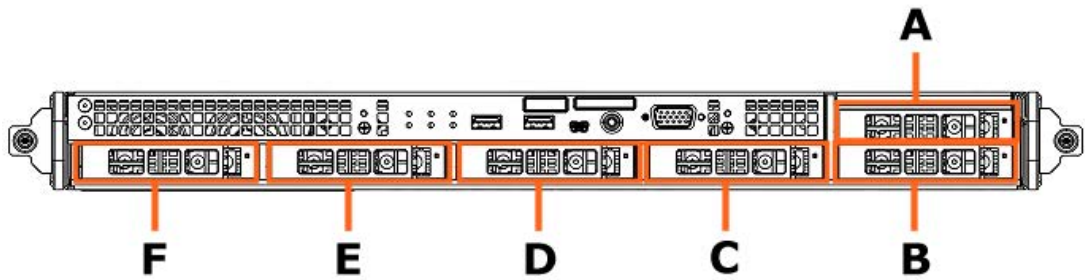

Mark	Description
A	2.5 inch SATA disk 0
B	2.5 inch SATA disk 1
C	2.5 inch SATA disk 2
D	2.5 inch SATA disk 3
E	2.5 inch SATA disk 4
F	2.5 inch SATA disk 5

## 2.6.2. M.2 NVMe disk option

 Top view

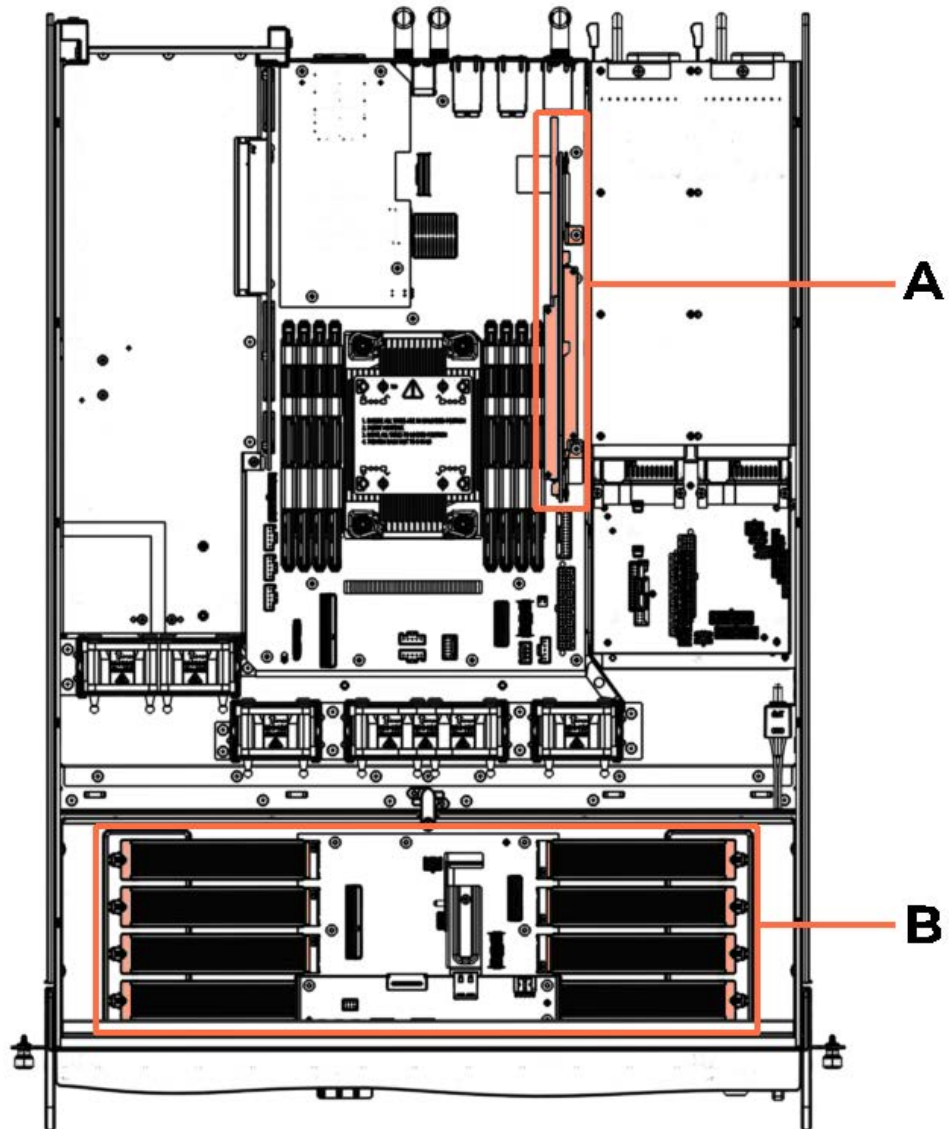

Mark	Description	Quantity
A	M.2 NVMe disks	2
B	M.2 NVMe disks	8

## M.2 NVMe disk numbering

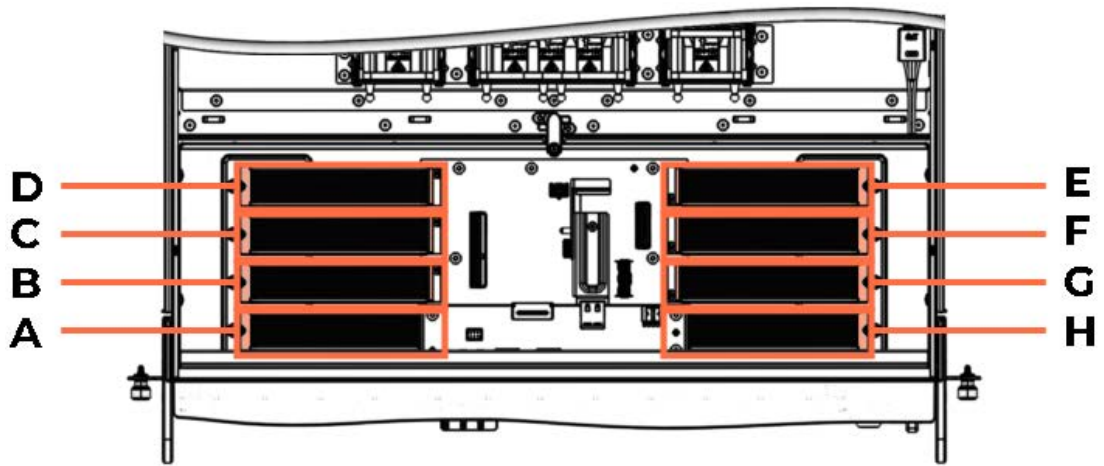

Mark	Description
A	M.2 NVMe disk 0
B	M.2 NVMe disk 1
C	M.2 NVMe disk 2
D	M.2 NVMe disk 3
E	M.2 NVMe disk 4
F	M.2 NVMe disk 5
G	M.2 NVMe disk 6
H	M.2 NVMe disk 7



# Chapter 3. Buttons, ports and LEDs

## 3.1. Front buttons, ports and LEDs

### 3.1.1. 2.5 inch SATA disk option

#### 3.1.1.1. Buttons

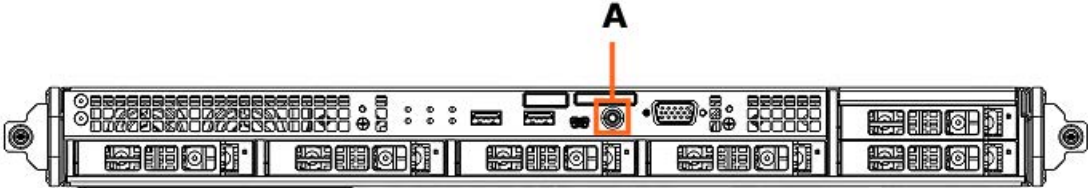

Mark	Description
A	Power On / Off

### 3.1.1.2. Ports

 Front view

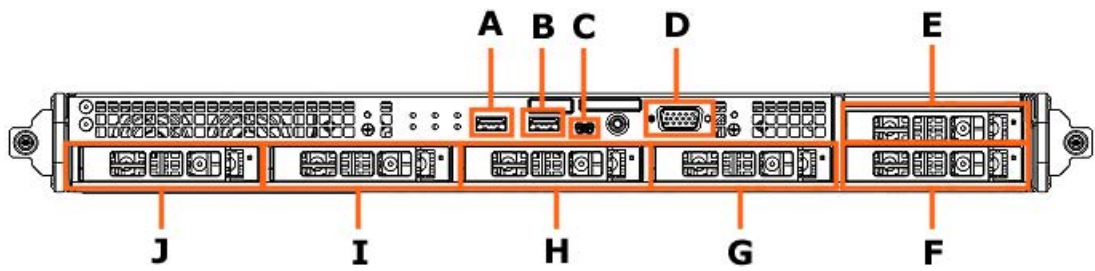

Mark	Description	Port identification
A	USB 3.1 Type A connector	Port 1
B	USB 3.1 Type A connector	Port 0
C	USB 2.0 MiniType B connector	N/A
D	VGA connector	N/A
E	Disk slot	Slot 0
F	Disk slot	Slot 1
G	Disk slot	Slot 2
H	Disk slot	Slot 3
I	Disk slot	Slot 4
J	Disk slot	Slot 5

### 3.1.1.3. LEDs

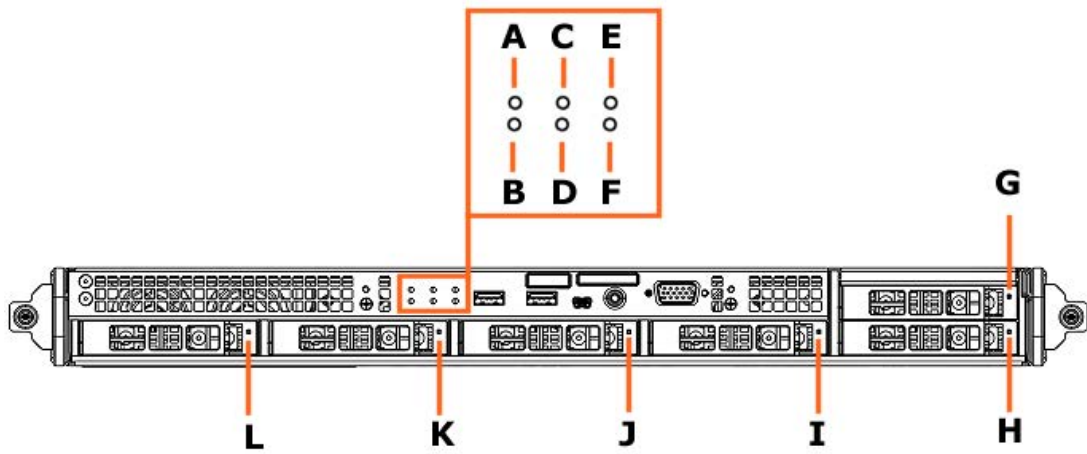

Mark	LEDs	color	Description
A	Temperature fault	Green	OK
		Blinking red	Warning
		Red	Error
B	WDT fault	Green	OK
		Blinking red	Warning limit overdue
		Red	Error limit overdue
C	Fan fault	Green	OK
		Blinking red	Non critical error
		Red	Critical error / fault error
D	DIMM fault	Green	OK
		Blinking red	Warning
		Red	Error
E	Power	Green	Module power on status
		Blinking green	Module standby status
		Blinking red	Recovery mode
		Red	Power supply error
F	ID	Blinking blue	Module identification
G	SDD0	Blinking green	SATA activity

Mark	LEDs	color	Description
H	SDD1	Blinking green	SATA activity
I	SDD2	Blinking green	SATA activity
J	SDD3	Blinking green	SATA activity
K	SDD4	Blinking green	SATA activity
L	SDD5	Blinking green	SATA activity

### 3.1.2. M.2 NVMe disk option

#### 3.1.2.1. Buttons

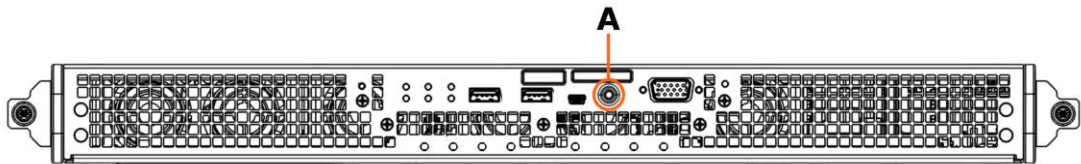

Mark	Description
A	Power On / Off

#### 3.1.2.2. Ports

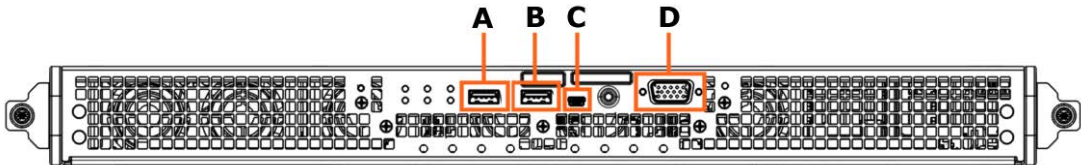

Mark	Description	Port identification
A	USB 3.1 Type A connector	Port 1
B	USB 3.1 Type A connector	Port 0
C	USB 2.0 Mini Type B connector	N/A
D	VGA connector	N/A

### 3.1.2.3. LEDs

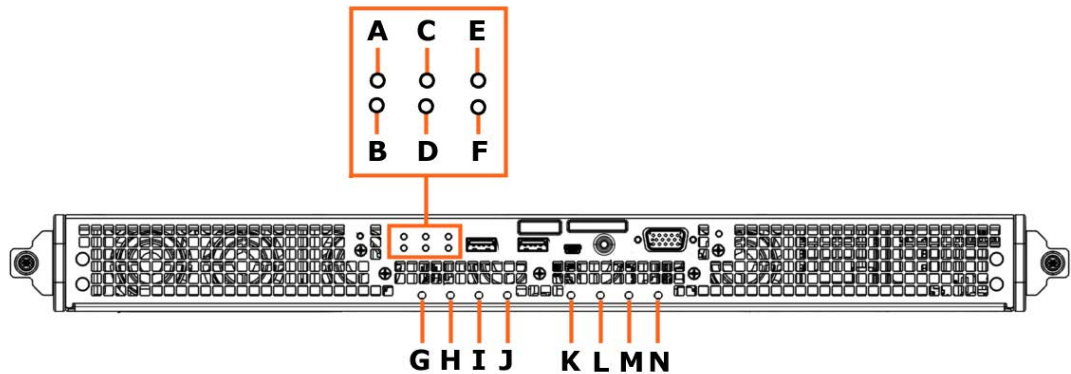

Mark	LEDs	Color	Description
A	Temperature fault	Green	OK
		Blinking red	Warning
		Red	Error
B	WDT (watch dog time) fault	Green	OK
		Blinking red	Warning limit overdue
		Red	Error limit overdue
C	Fan fault	Green	OK
		Blinking red	Non critical error
		Red	Critical error / fault error
D	DIMM fault	Green	OK
		Blinking red	Warning
		Red	Error
E	Power	Green	Module power on status
		Blinking green	Module standby status
		Blinking red	Recovery mode
		Red	Power supply error
F	ID	Blinking blue	Module identification
G	M.2 NVMe disk 0 activity	Blinking green	OK
		No LED	Fault / error or No AC power
H	M.2 NVMe disk 1 activity	Blinking green	OK
		No LED	Fault / error or No AC power

<b>Mark</b>	<b>LEDs</b>	<b>Color</b>	<b>Description</b>
I	M.2 NVMe disk 2 activity	Blinking green	OK
		No LED	Fault / error or No AC power
J	M.2 NVMe disk 3 activity	Blinking green	OK
		No LED	Fault / error or No AC power
K	M.2 NVMe disk 4 activity	Blinking green	OK
		No LED	Fault / error or No AC power
L	M.2 NVMe disk 5 activity	Blinking green	OK
		No LED	Fault / error or No AC power
M	M.2 NVMe disk 6 activity	Blinking green	OK
		No LED	Fault / error or No AC power
N	M.2 NVMe disk 7 activity	Blinking green	OK
		No LED	Fault / error or No AC power

## 3.2. Rear buttons, ports and LEDs

### 3.2.1. Buttons

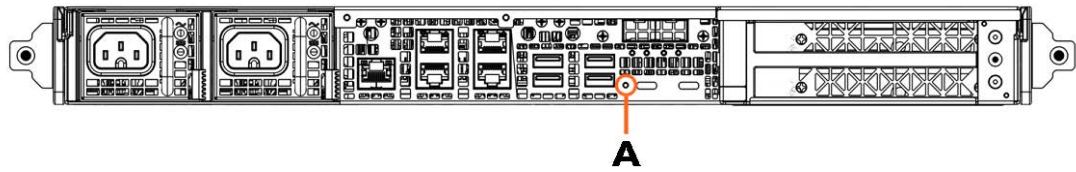

Mark	Function	Operation
A	BMC firmware recovery	Press the button in using a pointed object and release.
	Factory reset	Push the button in using a pointed object and hold it in for more than 10 seconds before releasing.

### 3.2.2. Ports

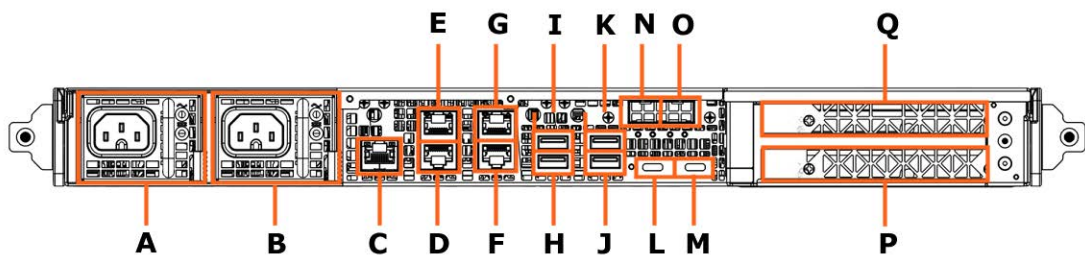

Mark	Description	Port identification
A	Power supply 0	PSU 0
B	Power supply 1	PSU 1
C	RJ45 - 1 Gb/s Ethernet LAN	BMC
D	RJ45 - 1 Gb/s Ethernet LAN	Port 0
E	RJ45 - 1 Gb/s Ethernet LAN	Port 1
F	RJ45 - 1 Gb/s Ethernet LAN	Port 2
G	RJ45 - 1 Gb/s Ethernet LAN	Port 3
H	USB 3.1 Type A	Port 0
I	USB 3.1 Type A	Port 1
J	USB 3.1 Type A	Port 2

<b>Mark</b>	<b>Description</b>	<b>Port identification</b>
K	USB 3.1 Type A	Port 3
L	USB 3.1 Type C	Port 0
M	USB 3.1 Type C	Port 1
N	SPF+ -10 Gb/s Ethernet (optional)	Port 0
O	SPF+ -10 Gb/s Ethernet (optional)	Port 1
P	x16 PCIe Riser	Slot 0
Q	x16 PCIe Riser	Slot 1



### 3.2.3. LEDs

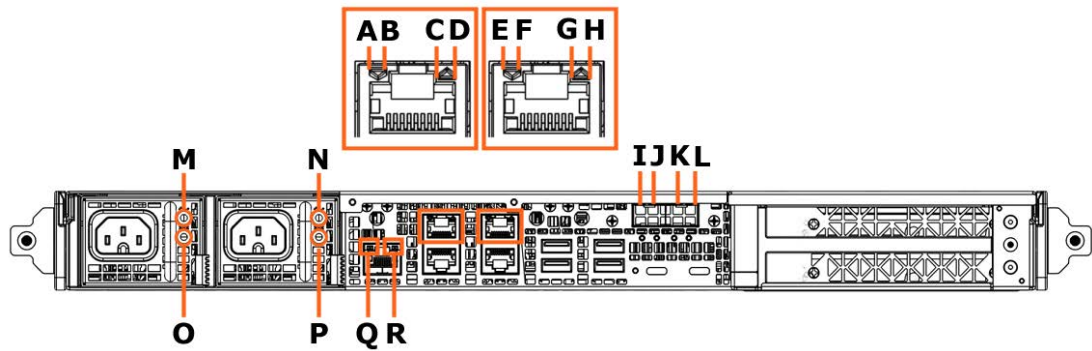

Mark	LEDs	Color	Description
A	RJ45 port 0	Green	1 Gb/s Ethernet speed up
B	RJ45 port 0	Blinking amber	Ethernet link activity
C	RJ45 port 1	Green	1 Gb/s Ethernet speed up
D	RJ45 port 1	Blinking amber	Ethernet link activity
E	RJ45 port 2	Green	1 Gb/s Ethernet speed up
F	RJ45 port 2	Blinking amber	Ethernet link activity
G	RJ45 port 3	Green	1 Gb/s Ethernet speed up
H	RJ45 port 3	Blinking amber	Ethernet link activity
I	Mezzanine 10 Gb/s port 0	Green	1 Gb/s Ethernet speed up
J	Mezzanine 10 Gb/s port 0	Blinking amber	Ethernet link activity
K	Mezzanine 10 Gb/s port 1	Green	1 Gb/s Ethernet speed up
L	Mezzanine 10 Gb/s port 1	Blinking amber	Ethernet link activity
M	PSU 0 input LED	Green	OK. Input voltage within specified range
		Blinking green	OV/UV WARNING. Input voltage in overvoltage/undervoltage range
		No LED	OFF or FAULT. Input voltage above overvoltage range / below undervoltage range or not present

Mark	LEDs	Color	Description
N	PSU1 input LED	Green	OK. Input voltage within specified range
		Blinking green	OV/UV WARNING. Input voltage in overvoltage/undervoltage range
		No LED	OFF or FAULT. Input voltage above overvoltage range / below undervoltage range or not present
O	PSU0 output LED	Green	POWER GOOD. Both outputs operating normally; no warnings or faults
		Blinking green	STANDBY. Main output disabled via PS_ON signal; standby output operating normally (no warnings or faults)
		Blinking amber	WARNING. Power supply warning detected as per PMBus™ STATUS_X reporting bytes
		Amber	FAULT. Power supply fault detected as per PMBus™ STATUS_X reporting bytes
P	PSU1 output LED	Green	POWER GOOD. Both outputs operating normally; no warnings or faults
		Blinking green	STANDBY. Main output disabled via PS_ON signal; standby output operating normally (no warnings or faults)
		Blinking amber	WARNING. Power supply warning detected as per PMBus™ STATUS_X reporting bytes
		Amber	FAULT. Power supply fault detected as per PMBus™ STATUS_X reporting bytes
Q	RJ45 BMC	Green	1 gb/s Ethernet speed up
R	RJ45 BMC	Blinking amber	Ethernet link activity

---

## Appendix A. Technical description

---

### A.1. General technical specifications

<b>Operating limits</b>	
Ambient air temperature	0 °C to 45 °C; gradient 20 °C / hour
Relative humidity (non condensing)	5 % to 85 %; gradient 5 % / hour
Pressure	70 to 106 kPa
Elevation	Sea level < 3000 m
<b>Non-operating limits</b>	
Ambient air temperature	< -20 °C and > 60°C
Relative humidity (non condensing)	< 5 % and > 95 %; gradient 30 % / h
Moisture content	1 to 29 g / m <sup>3</sup>
<b>Shipping limits</b>	
Operating air temperature	-20 °C to 60 °C ; gradient 25 °C / hour
Relative humidity (non condensing)	5 % to 95 %; gradient 30 % / hour

---

## A.2. Dimensions and weight

<b>BullSequana EXR &amp; AI100R</b>	
Height	1 U - 44 mm
Width	430 mm
Depth	550 mm
Weight	~ 15 kg

---

### A.3. Module technical specifications

<b>Electrical specifications</b>	
Each BullSequana EXR & AI100R module is equipped with two redundant PSUs	
Rated Current	11 - 6 A
Power consumption	Typical: < 1000 W
Thermal dissipation	Maximum: 1100 W
Rated Voltage Range	100 - 240 VAC
Rated Frequency Range	50 / 60 Hz
<b>Environmental specifications</b>	
Noise	25 °C inlet, 75 % of worst TDP power : 75 dB
IP protection Class	IP 20 without front bezel / filter IP 40 with front bezel / filter

## A.4. Server technical description

<b>Processor</b>	
Number	One processor per module
Type	Fourth generation Intel Xeon Scalable processors
<b>Architecture</b>	
Platform	Based on Intel Eagle Stream Platform
<b>Memory</b>	
Minimum / Maximum	Up to 1 TB
Type	DDR5 RDIMM Up to 4400 MT / s
Slots	Eight per module
<b>I/O slots per module</b>	
Bus slots	Two 16 Gen5 PCIe slots
<b>I/O ports per module</b>	
USB ports	Rear: six USB 3.1 Front: two USB 3.1
Ethernet ports	Two 10 Gb / s and five 1 Gb / s Ethernet ports
<b>Disk bays per module</b>	
Disks	Internal: two M.2 NVMe disks Storage: up to eight M.2 NVMe disks or six 2.5 inch SATA disks
<b>GPUs per module</b>	
GPUs	Up to two 150 W GPU cards or one 300 W GPU card

## A.5. Antenna specifications

### A.5.1. Dual-band WiFi

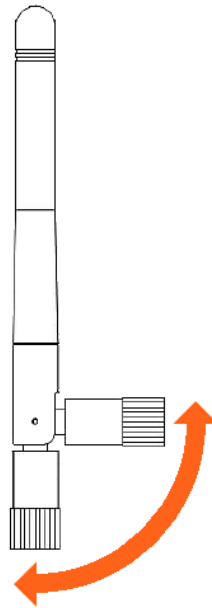

Dimensions	
Unfolded height	108 mm
Unfolded height	78 mm
Maximum width	10 mm
Minimum width	8 mm
Attached depth	31 mm
Technical specifications	
Frequency	2.4 - 5.9 GHz
Voltage Standing Wave Ratio	$\leq 2.5 : 1$
Gain	2.5 dB
Polarization	Vertical
Impedance	50 $\Omega$
Max power	20 W
Environmental characteristics	
Operating temperature	- 40°C to + 85°C
Compliance	RoHS compliant

## A.5.2. LoraWAN

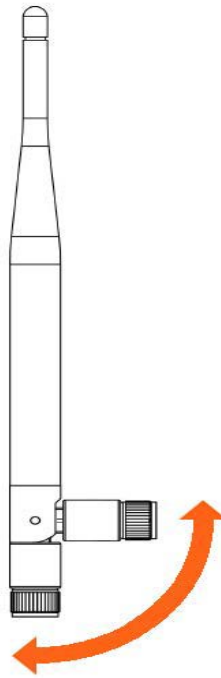

<b>Dimensions</b>	
Unfolded height	197 ± 3 mm
Unfolded height	173 ± 2 mm
Maximum width	13 mm
Minimum width	6 mm
Attached depth	37.3 ± 0.5 mm
<b>Technical specifications</b>	
Frequency	868 MHz
Voltage Standing Wave Ratio	< 2.0
Gain	3 dBi
Polarization	Linear
Impedance	50 Ω
Max power	20 W
<b>Environmental characteristics</b>	
Operating temperature	- 40°C to + 85°C
Vibration	10 to 55 Hz with 1.5 mm amplitude 2 hours
Compliance	RoHS compliant



### A.5.3. LTE / 5G

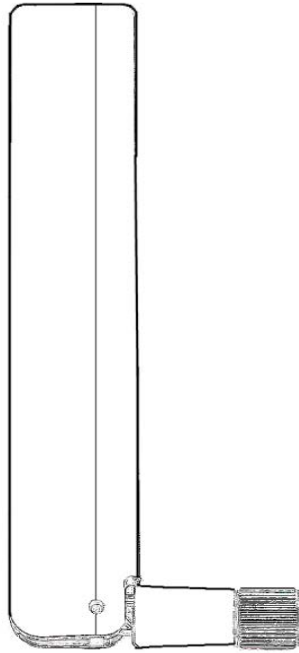

Dimensions			
Height	135 mm		
Width	10 mm		
Attached depth	19 mm		
Technical specifications			
Frequency (MHz)	617-960	1427-2690	3300-5000
Voltage Standing Wave Ratio	~2.0:1	~2.6:1	~2.3:1
Peak gain (dBi)	~-1.1	~0.5	~0.3
Average gain (dB)	~-4.3	~-3.8	~-4.6
Polarization	Linear		
Impedance	50 $\Omega$		
Max power	25 W		
Environmental characteristics			
Operating temperature	- 40°C to + 85°C		
Compliance	RoHS compliant		



---

# Acronyms

---

## A

No entries

---

## B

### BIOS

Basic Input / Output System

### BMC

Baseboard Management Controller

---

## C

### CPU

Central Processing Unit

### CRU

Customer Replaceable Unit

---

## D

### DDR5

Double Data Rate fifth generation

### DIMM

Dual In-line Memory Module

---

## E

No entries

---

## F

### FPB

Front Panel Board

### FPGA

Field Programmable Gate Array

### FRU

Field Replaceable Unit

---

## G

### GPU

Graphical Processing Unit

### GSM

Global System for Mobile communications

---

## **H**

### **HTTPS**

HyperText Transfer Protocol Secure

---

## **I**

### **IP**

Internet Protocol

---

## **J**

**No entries**

---

## **K**

**No entries**

---

## **L**

### **LAN**

Local Area Network

### **LED**

Light Emitting Diode

### **LoRa**

Long Range wireless communication

### **LoRaWAN**

Long Range Wide Area Network

### **LTE**

Long Term Evolution

---

## **M**

### **MAC**

Media Access Control

### **MI**

Machine Intelligence

### **MISM**

Machine Intelligence System Management

### **MIPSE**

Machine Intelligence Pocket Server

---

## **N**

### **NVMe**

Non-Volatile Memory express

---

## **O**

**No entries**

---

---

## **P**

### **PDB**

Power Distribution Board

### **PCI**

Peripheral Component Interconnect

### **PCIe**

PCI Express

### **PDU**

Power Distribution Unit

### **PSU**

Power Supply Unit

---

## **Q**

**No entries**

---

## **R**

### **RDIMM**

Registered Dual In-line Memory Module

### **REST**

Representational State Transfer

---

## **S**

### **SATA**

Serial ATA

### **SEL**

System Event Log

### **SSD**

Solid State Drive

### **SSH**

Secured Shell

### **SSL**

Secure Socket Layer

---

## **T**

### **TDP**

Thermal Design Point

---

## **U**

### **USB**

Universal Serial Bus

---

**V****VGA**

Video Graphic Array

---

**W****WIFI**

Wireless Fidelity

**WDT**

Watch Dog Timer

---

**X**

**No entries**

---

**Y**

**No entries**

---

**Z**

**No entries**



