

# NovaScale Master Server Add-ons

Installation and  
Administrator's Guide

NOVASCALE



REFERENCE  
86 A2 95ER 01



# NOVASCALÉ

# NovaScale Master Server Add-ons

## Installation and Administrator's Guide

### **Software**

October 2006

BULL CEDOC  
357 AVENUE PATTON  
B.P.20845  
49008 ANGERS CEDEX 01  
FRANCE

REFERENCE  
86 A2 95ER 01

The following copyright notice protects this book under Copyright laws which prohibit such actions as, but not limited to, copying, distributing, modifying, and making derivative works.

Copyright © Bull SAS 1992, 2006

Printed in France

Suggestions and criticisms concerning the form, content, and presentation of this book are invited. A form is provided at the end of this book for this purpose.

To order additional copies of this book or other Bull Technical Publications, you are invited to use the Ordering Form also provided at the end of this book.

### **Trademarks and Acknowledgements**

We acknowledge the right of proprietors of trademarks mentioned in this book.

Intel® and Itanium® are registered trademarks of Intel Corporation.

Windows® and Microsoft software® are registered trademarks of Microsoft Corporation.

UNIX® is a registered trademark in the United States of America and other countries licensed exclusively through the Open Group.

Linux® is a registered trademark of Linus Torvalds.

*The information in this document is subject to change without notice. Bull will not be liable for errors contained herein, or for incidental or consequential damages in connection with the use of this material.*

---

# Table of Contents

<b>Preface</b> .....	<b>v</b>
Scope and Audience of this Manual .....	v
Using this Manual .....	v
Related Information .....	v
Highlighting .....	vi
<b>Chapter 1. NovaScale Master Server Add-Ons Concepts</b> .....	<b>1-1</b>
NovaScale Master .....	1-1
Overview .....	1-1
Monitoring .....	1-2
Event Reception .....	1-2
Hardware Manager .....	1-2
Storage Manager .....	1-2
NovaScale Master Server Add-Ons .....	1-3
Internal Storage (free) .....	1-3
NSMasterGAMTT for LSI MegaRAID 320-2x management .....	1-3
NSMasterLSICIM for LSI 22320 chip management .....	1-5
External Storage (not free) .....	1-6
NSMasterStoreWayFDA for StoreWay FDA management .....	1-6
Bull products (not free) .....	1-6
NSMasterDD4A for Bull Dynamic Domains For Applications Management .....	1-6
NSMasterBVS for Bull Video Services Management .....	1-7
<b>Chapter 2. NovaScale Master Server Add-Ons Installation</b> .....	<b>2-1</b>
General Installation Requirements .....	2-1
Supported Operating Systems .....	2-1
Required Disk Space .....	2-1
Required Memory .....	2-1
Installation and Operational Requirements .....	2-1
Restrictions .....	2-2
Installing NovaScale Master Server Add-Ons for Windows .....	2-2
Prerequisites .....	2-2
Installing Free Management Server Add-Ons from the CD-ROM .....	2-3
Installing not Free Management Server Add-Ons packages .....	2-4
Uninstalling NovaScale Master Server Add-Ons Components .....	2-4
Upgrading to a New NovaScale Master Server Add-Ons Version .....	2-5
Installing NovaScale Master Server Add-Ons for Linux .....	2-5
Prerequisites .....	2-5
Installing Free Management Server Add-Ons from the CD-ROM .....	2-5
Installing not Free Management Server Add-Ons packages .....	2-7
Uninstalling NovaScale Master Server Add-On Components .....	2-7
Upgrading to a new NovaScale Master Server Add-Ons Version .....	2-7
<b>Chapter 3. Monitoring Configuration</b> .....	<b>3-1</b>
Overview .....	3-1
Configuration GUI .....	3-1
Starting the Configuration GUI .....	3-1

Monitoring Details .....	3-1
Internal Storage Categories & Services .....	3-2
NSMasterGAMTT (LSI (Mylex) RAID Management) .....	3-2
NSMasterLSICIM (LSI SCSI RAID Management) .....	3-2
External Storage Categories & Services .....	3-3
NSMasterStoreWayFDA (StoreWay FDA Management) .....	3-3
Bull Products Categories & Services .....	3-3
NSMasterBVS ("Bull Video Services" Management) .....	3-3
NSMasterDD4A ("Dynamic Domains For Applications" Management) .....	3-4
Internal Storage Check Commands .....	3-4
NSMasterGAMTT (LSI (Mylex) SCSI RAID management) .....	3-4
NSMasterLSICIM (LSI SCSI RAID Management) .....	3-5
External Storage Check Commands .....	3-5
NSMasterStoreWayFDA (StoreWay FDA Management) .....	3-5
Bull Products Check Commands .....	3-5
NSMasterDD4A ("Dynamic Domains For Applications" Management) .....	3-5
NSMasterBVS ("Bull Video Services" Management) .....	3-5
<b>Chapter 4. Check Commands for Customizable Services of Add-Ons .....</b>	<b>4-1</b>
Internal Storage Management .....	4-1
NSMasterGAMTT .....	4-1
check_gamttRAID .....	4-1
NSMasterLSICIM .....	4-3
check_LSICIM .....	4-3
External Storage Management .....	4-5
NSMasterStoreWayFDA .....	4-5
check_NECFDA .....	4-5
Bull Products Management .....	4-6
NSMasterDD4A .....	4-6
check_DynamicDomains .....	4-6
NSMasterBVS .....	4-7
check_BVS .....	4-7
<b>Index .....</b>	<b>X-1</b>

---

# Preface

---

## Scope and Audience of this Manual

NovaScale Master Server Add-Ons are Bull products which provide extension to NovaScale Master for managing Bull Intel platforms specific devices or tools. Administration environments can include different platforms from the NovaScale Series or Express 5800 Series servers.

In order to monitor a specific item, NovaScale Master Server Add-Ons configuration must be customized. This manual explains also how, as an Administrator you can perform configuration tasks for these Add-Ons.



**Note:**

Configuration tasks may only be performed by Administrators.

---

## Using this Manual

For a conceptual approach to NovaScale Master Server Add-Ons, read [Chapter 1 NovaScale Master Server Add-Ons Concepts](#).

Chapter 2 describes how to install NovaScale Master Server Add-Ons.

Chapter 3 describes how to configure NovaScale Master Server Add-Ons elements on the Management server.

They provide detailed information about all resource properties as well as concrete examples to help customization of the configuration (Modifying Service Parameters, ...).

This chapter also contains reference information about categories and services of the monitoring server provided by these NS Master Server Add-Ons.

[Check Commands for Customizable Services](#) contains reference information about the check commands used by NS Master Server Add-Ons monitoring services.

---

## Related Information

### NovaScale Master Documentation

- The NovaScale Master GUI (Graphical User Interface) is not described in the present guide. For information about the GUI and the way to use it, please refer to the *NovaScale Master User's Guide* (Ref. 86 A2 49EG).
- Restrictions and well-known problems are described in the associated *Release Notes* document.

---

## Highlighting

The following highlighting conventions are used in this book:

<b>Bold</b>	Identifies commands, keywords, files, structures, directories and other items whose names are predefined by the system. Also identifies graphical objects such as buttons, labels and icons that the user selects.
<i>Italics</i>	Identifies chapters, sections, paragraphs and book names to which the reader must refer for details.
Monospace	Identifies examples of specific data values, examples of text similar to displayed messages from the system, or information you should actually type.



**Note:**

Important information.



---

## Chapter 1. NovaScale Master Server Add-Ons Concepts

NovaScale Master monitoring ensures the following tasks:

- Monitoring NovaScale machines: NovaScale Master checks if these hosts are accessible, using the **ping** command from the System Manager. The machines to be monitored are either explicitly specified by the administrator or selected by a discovery mechanism.
- Monitoring specific elements of the hardware, operating system, services and Internet such as Power Status, **CPU load, memory usage, disk usage, number of users, processes** and **service execution, http and ftp services**.

The administrator can define status thresholds (OK, WARNING, CRITICAL, UNKNOWN) for each monitoring element. When an anomaly occurs or when normal status is recovered, **alerts** (in a log file) and **notifications** (by e-mail, by Bull autocall and/or by SNMP trap) are generated.



### Note:

Hardware and OS monitoring for Bull Intel-Based platforms are provided by the NovaScale Master Server package, not by the Add-Ons packages.

NovaScale Master Server Add-Ons extend the NS Master monitoring with more specific links to third-party management tools for specific devices or/and specific system functionalities.



### Note:

These Server Add-Ons packages extend generally the management server independently of the platform or/and OS type (storage, network, virtualization, framework, ...).

---

## NovaScale Master

### Overview

NovaScale Master, a tool for monitoring and managing Bull NovaScale and Express 5800 systems, consists of three main components that can be deployed on Windows and Linux systems:

- Management Server and Server Add-ons
- Management Console
- Management Agent.

#### Management Server and Server Add-ons

Provides the infrastructure and services in charge of collecting and operating management data. Management Server must be installed on the server dedicated to management.

#### Management Console

Provides third-party management tools for the end-user station running the NovaScale Master console WEB GUI.

#### Management Agent

Provides instrumentation and administration tools for monitored servers. Management Agent must be installed on each server to monitor.

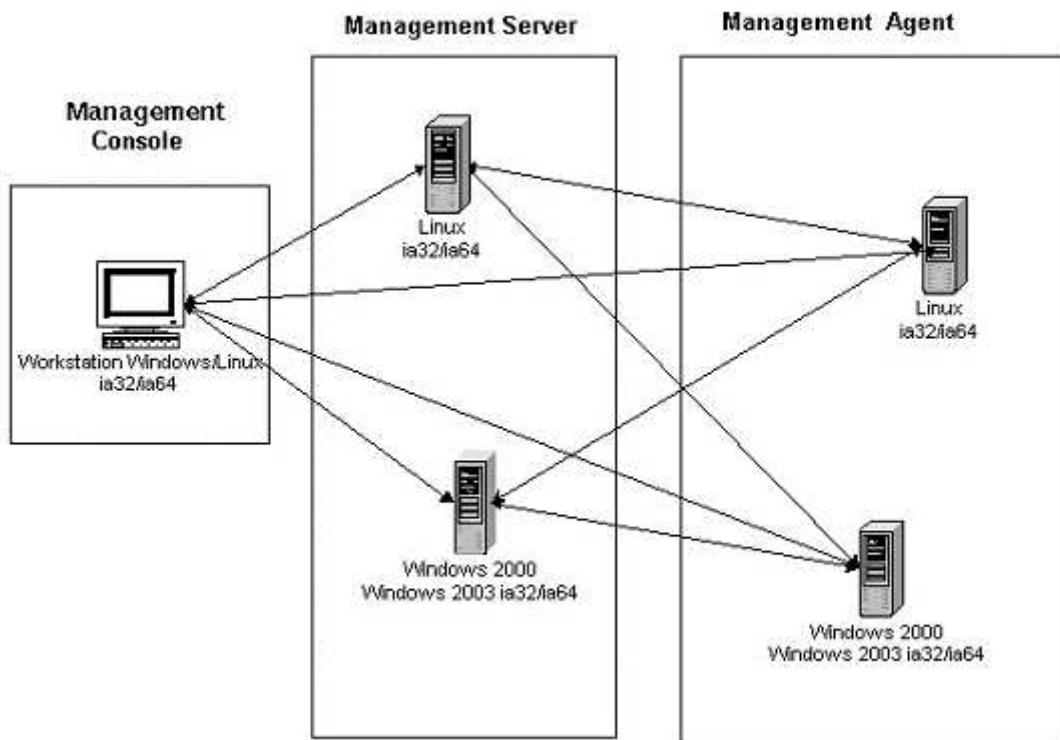

Figure 1. NovaScale Master Architecture



**Note:**

NovaScale Master for Windows and Linux are distributed on the same CD-ROM.

## Monitoring

A **Service** (or monitoring service) defines how specific host elements are monitored. A service can be defined for all hosts or for a list of hosts, depending on the OS (Windows, Linux or both) and/or on the model. Notification properties are defined for each service.

Services are organized into monitoring **categories**. For instance, the **SystemLoad** category includes the **CPU** and **Memory** services for a Windows host.

## Event Reception

NovaScale Master can receive **SNMP traps** from any SNMP agent. SNMP traps enable an agent to notify the NovaScale Master Server of significant events via an unsolicited SNMP message. SNMP Traps must be defined in a **MIB** (Management Information Base).

## Hardware Manager

A **Hardware Manager** manages hardware for one or a set of servers.

## Storage Manager

A **Storage Manager** manages storage for one or a set of servers.

---

## NovaScale Master Server Add-Ons

**NovaScale Master Server Add-Ons** deliver optional management packages to extend NovaScale Master Server.

A NovaScale Master Server Add-On provides functional links (monitoring, GUI call, reporting, ...) between a NovaScale Master Server and a third-party management tool.

Some free Server Add-Ons are distributed on the NovaScale Master Add-Ons CD-ROM.

 **Note:**

There is a difference between the Server Add-On and the third-party management tool. Even if the third-party management tool may be dedicated to an OS or/and a platform type, its NS Master Server Add-On will be able to be installed on a NS Master Server machine. (Thus, on Linux and on Windows, on IA32 and on IA64, ...).

This release provides five NovaScale Master Server Add-Ons. Some are free and delivered on the NovaScale Master CD-ROM, the others must be purchased.

### Internal Storage (free)

#### NSMasterGAMTT for LSI MegaRAID 320-2x management

**GAMTT** (or **GAM**) is the LSI tool to survey, configure and control RAID provided by LSI MegaRAID Ultra320 SCSI cards.

See <http://www.lsilogic.com/products/megaraid/index.html> to get more information or to download the GAMTT install package.

 **Note:**

This tool runs on NovaScale machines under Linux or Windows.

The corresponding NS Master Add-On creates monitoring links between NS Master and the **GAM** SNMP agent.

The following figure shows the different components used for this monitoring:

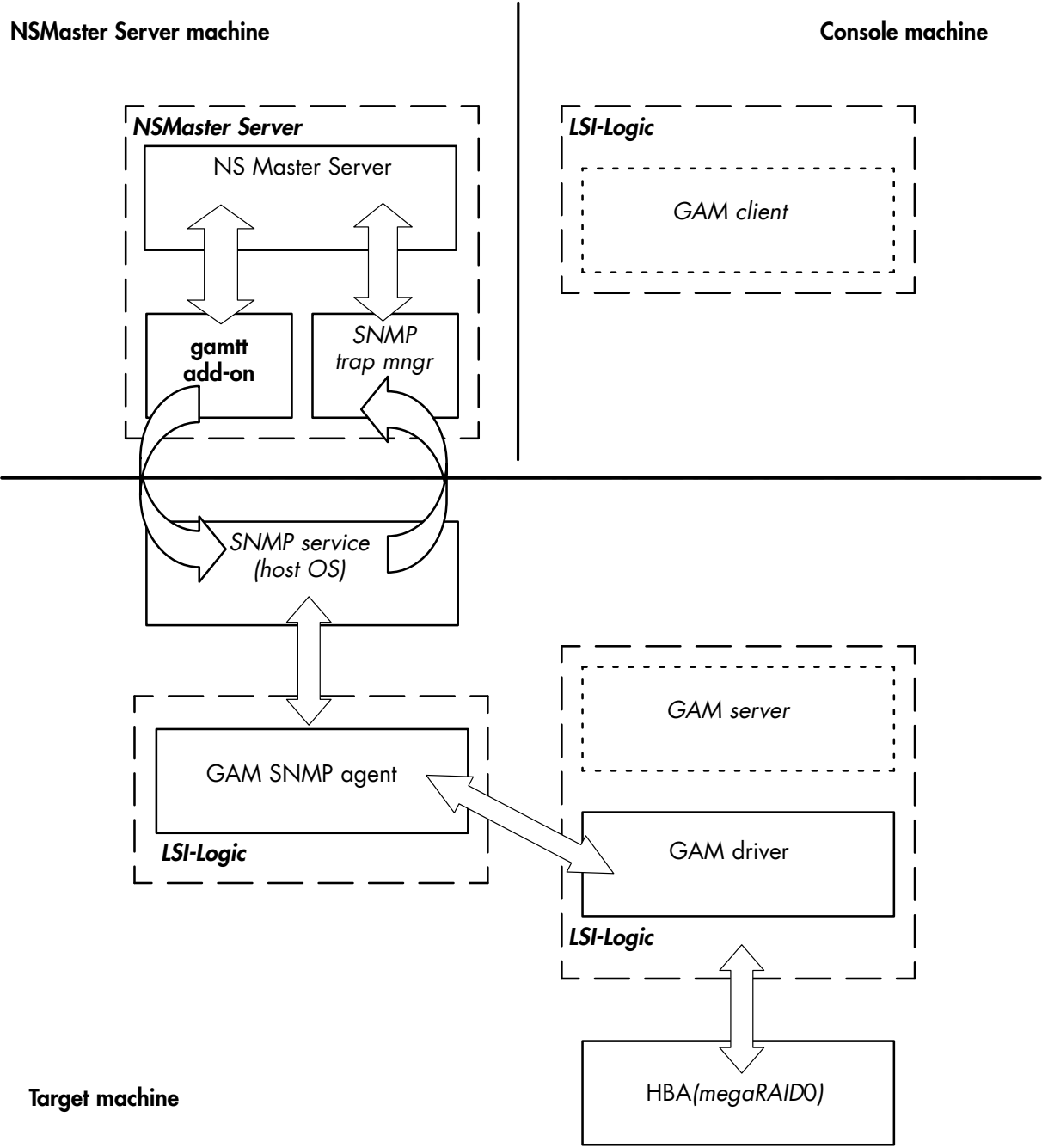

Figure 2. GAM Monitoring Components

## NSMasterLSICIM for LSI 22320 chip management

LSI CIM is the LSI tool used to survey, configure and control RAID provided by LSI MegaRAID 22320 SCSI cards.

See <http://www.lsiilogic.com/products/megaraid/index.html> for more information or to download the LSI CIM install package.

### Note:

This tool runs on NovaScale machines under Linux or Windows.

The corresponding NS Master Add-On creates monitoring links between NS Master and the **LSI CIM** provider.

The following figure shows the different monitoring components:

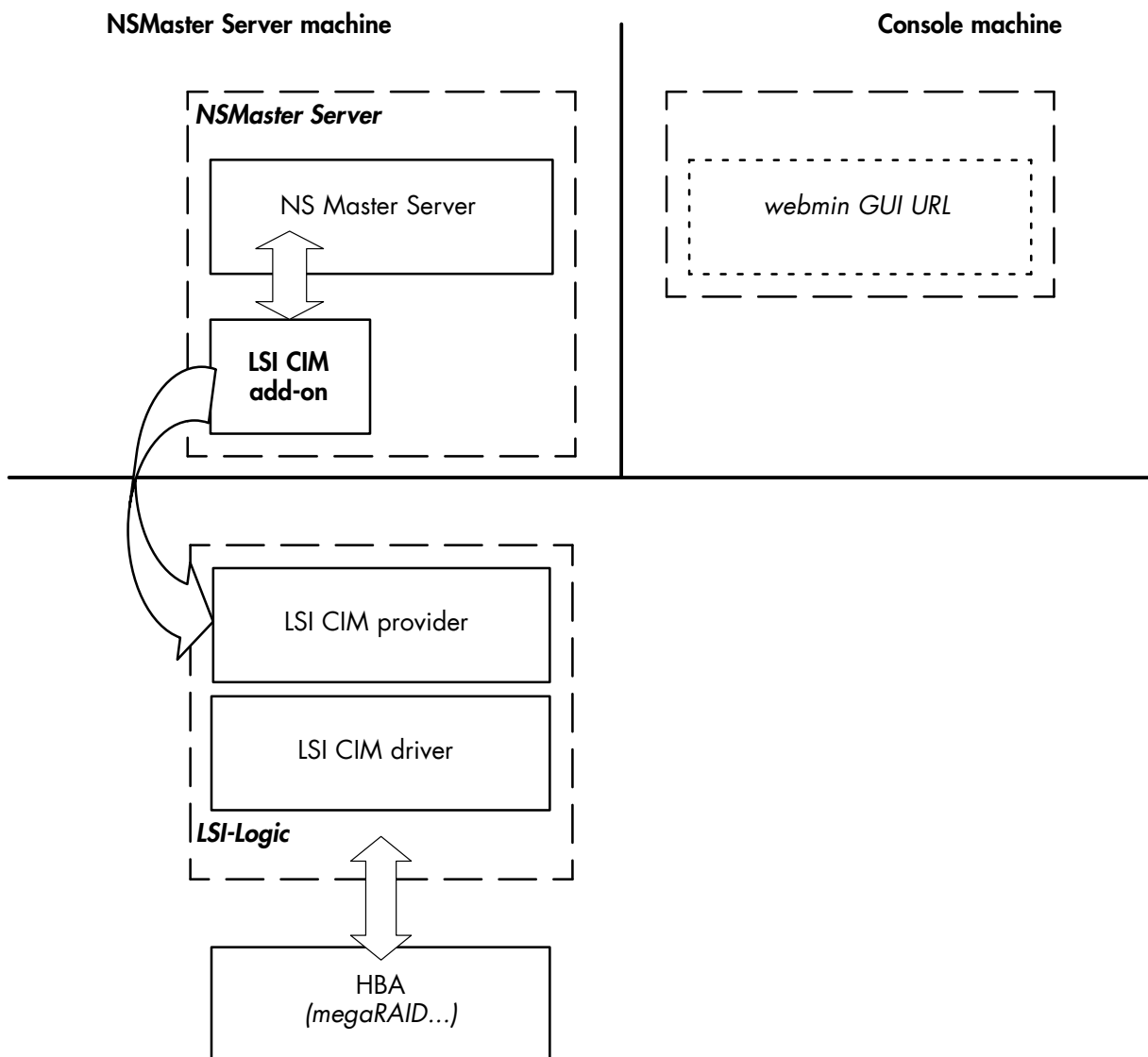

Figure 3. LSI CIM Monitoring Components

## External Storage (not free)

### NSMasterStoreWayFDA for StoreWay FDA management

The corresponding NS Master Add-On creates monitoring links between NS Master and the StoreWay FDA SNMP agent.

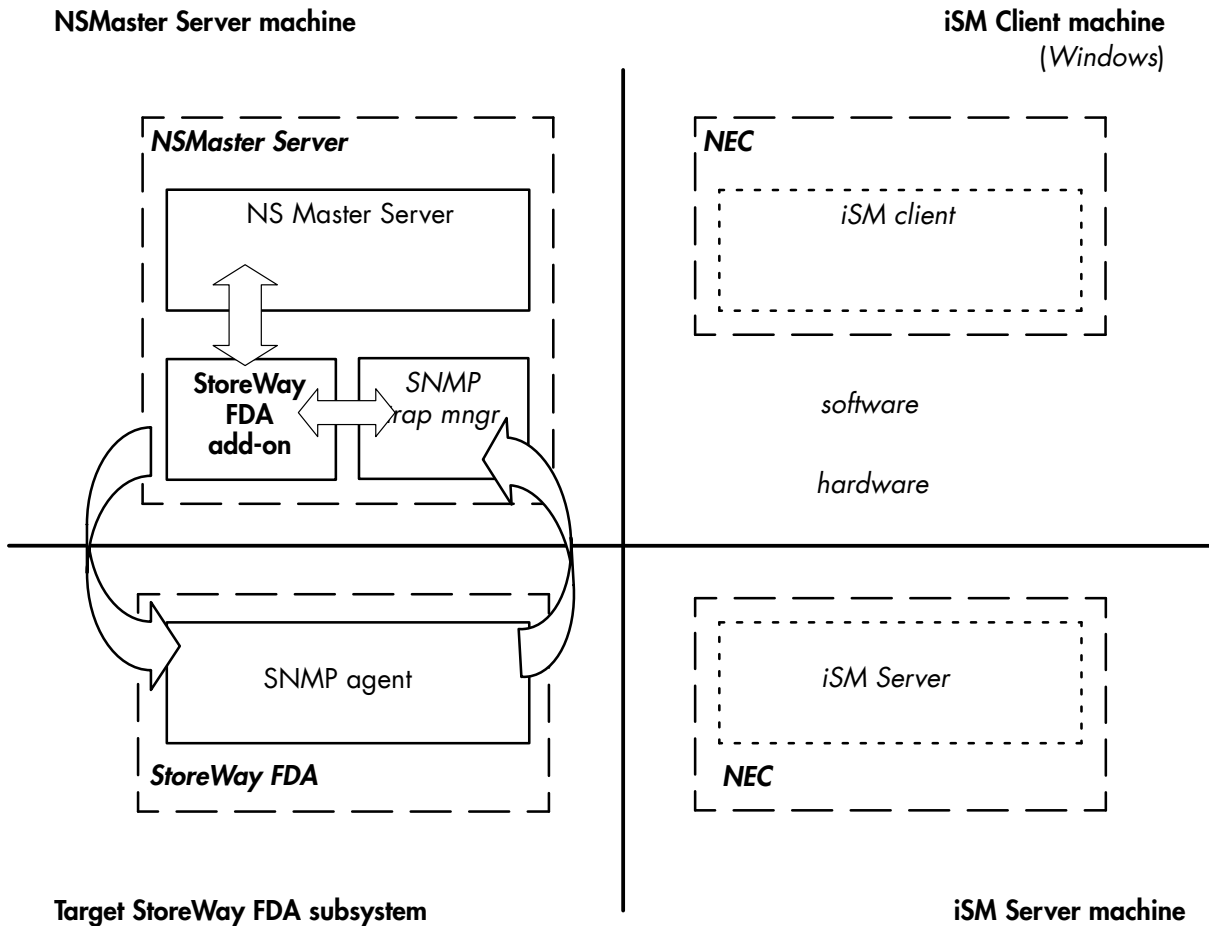

Figure 4. StoreWay FDA Monitoring Components

## Bull products (not free)

### NSMasterDD4A for Bull Dynamic Domains For Applications Management

The "Dynamic Domains For Applications" software is a tool that can be used on the Linux operating system for simulating the partitioning of a multi-CPU machine at application level. The "Dynamic Domains" software can be used with standard Linux distributions and can be managed using the Webmin standard administration tool.

See the *Dynamic Domains for Applications User's Guide* (ref 86A263ER00) to get more information.

You can install DD4A from the CD "Bull Extension Pack for RedHat" (ref 76741846-xxx).



#### Note:

**DD4A** runs only on Linux machines and uses a Webmin module for its management. You can download the prerequisite Webmin package from the web site: <http://www.webmin.com>.

This Add-On creates monitoring links between NS Master and the **DD4A** management webmin module.

The following figure shows the different components used for this monitoring:

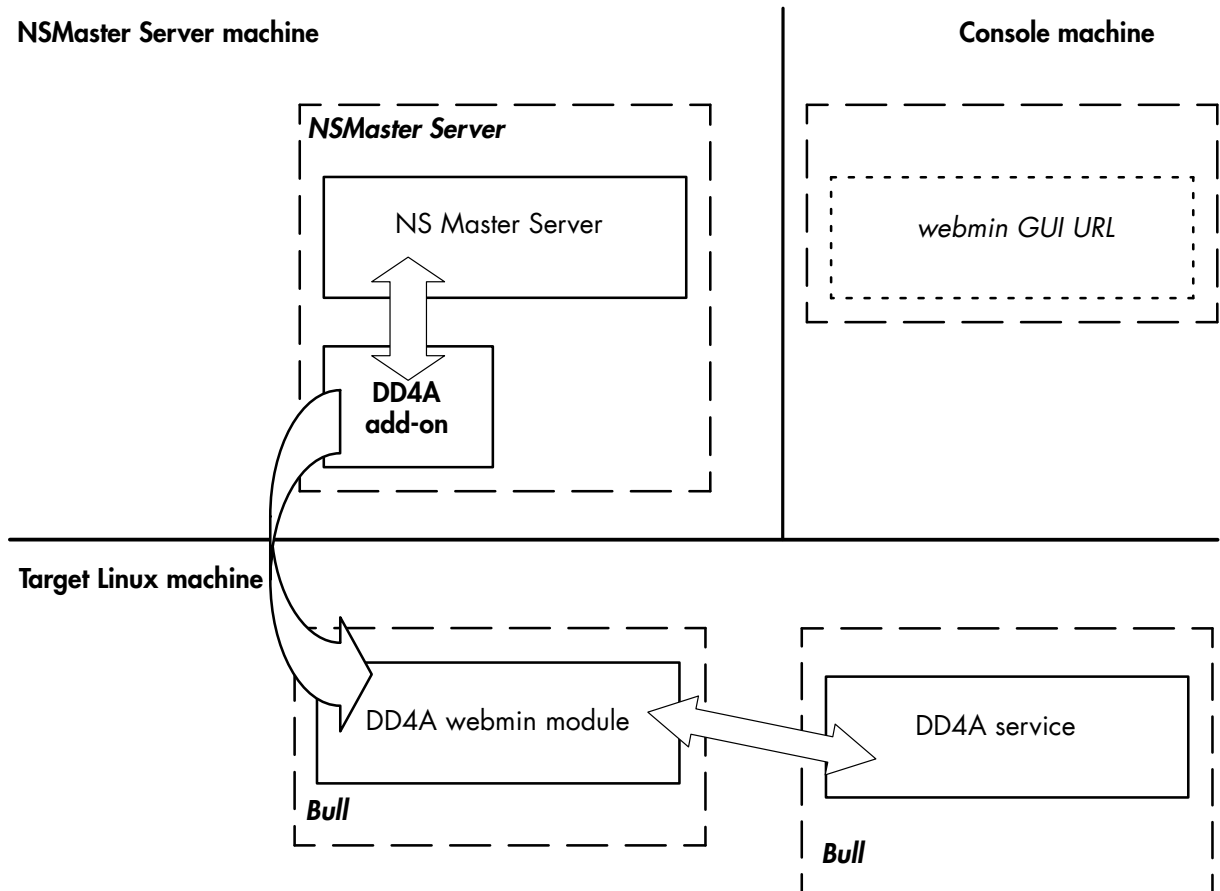

Figure 5. DDA4 Monitoring Components

### NSMasterBVS for Bull Video Services Management

**Bull Video Services** software is a tool that can be used with standard Linux distributions and can be managed using the Webmin standard administration tool.

See the *Bull Video Services User's Guide* for more information.

You can install BVS from the Bull Video Services CD (ref 36673900-xxx).

 **Note:**

**BVS** runs only on Linux machines and uses a Webmin module for its management.

You can download the required Webmin package from the following web site:

<http://www.webmin.com>.

This Add-On creates monitoring links between NS Master and the **BVS** management webmin module.

The following figure shows the different monitoring components:

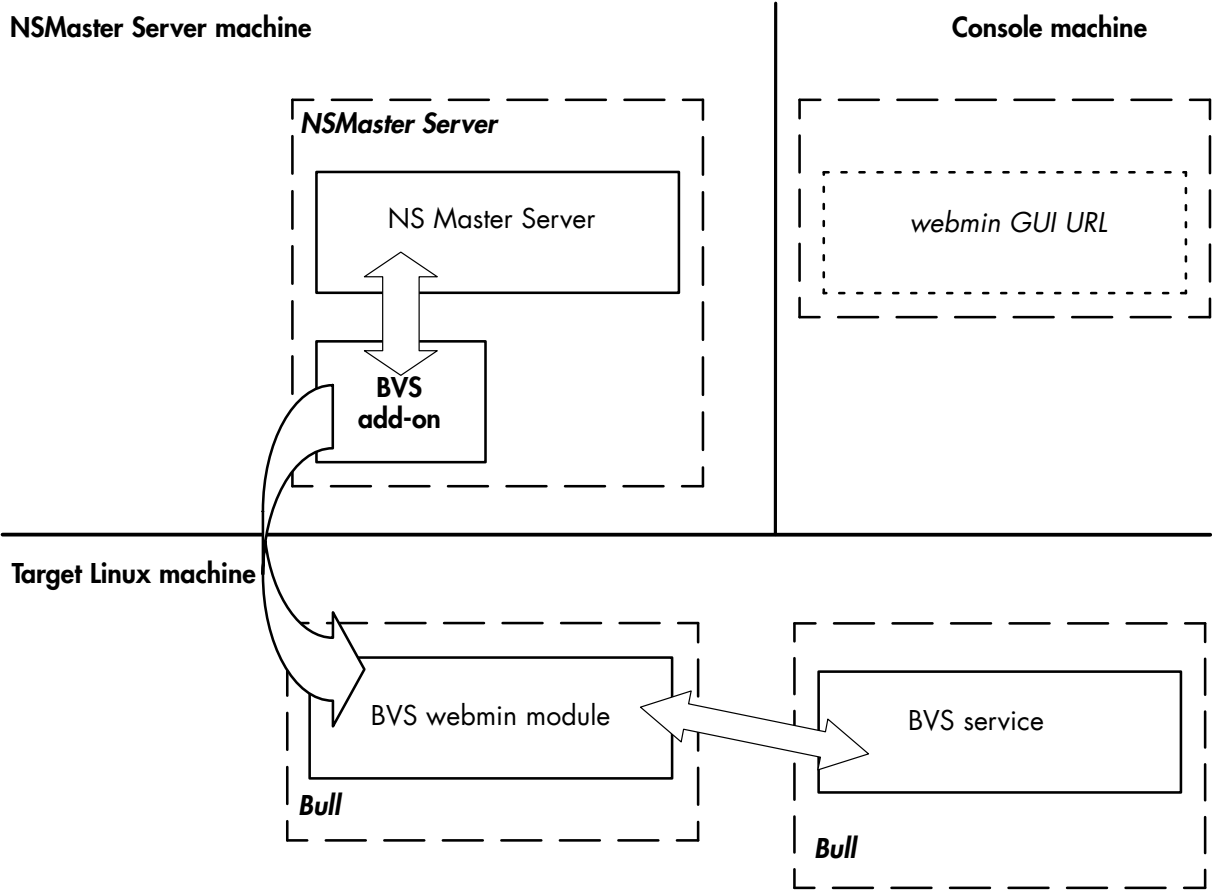

Figure 6. BVS Webmin Monitoring Components



---

## Chapter 2. NovaScale Master Server Add-Ons Installation

---

### General Installation Requirements

Before installing NovaScale Master, check that the environment meets the software and hardware requirements described below.

### Supported Operating Systems

NovaScale Master Server Add-Ons operate on Linux and Windows operating systems.

The principal Requirements are the NovaScale Master Server pre-installation and its own requirements.

(See NovaScale Master Installation guide).

### Required Disk Space

The following table indicates the required disk space for Management Add-Ons.

<b>NovaScale Master Server Add-Ons</b>	<b>Windows</b>	<b>Linux</b>
LSI GAMTT Mgt Package	1MB	1MB
LSI CIM Mgt Package	1 Mb	1 Mb
StoreWay FDA Mgt Package	1 Mb	1 Mb
Dynamic Domains Mgt Package	1MB	1MB
Bull Video Service Mgt Package	1 Mb	1 Mb

Table 1. NovaScale Master Server Add-Ons- Required Disk Space.

### Required Memory

The following table indicates the required memory for Management Server.

<b>NovaScale Master</b>	<b>Memory</b>
Management Server	512MB

Table 2. NovaScale Master - Required Memory.

### Installation and Operational Requirements

#### Installation Requirements

<b>Server Add-ons</b>	<b>Component</b>
*	NSMasterServer5.0-x

Table 3. Management Server Add-Ons Installation Requirements

## Operational Requirements

Server Add-ons	Target Tools
NSMasterGAMTT	Linux GAM version 6.02.31 or higher. Windows GAM version 6.02-32 or higher. Important: Contact <www.lsilogic.com> web site to download the above versions. If not on-line, contact the Bull support team. Note: For <b>IA32</b> machines the following previous versions are supported: Linux GAM version 6.02-21 or higher Windows GAM version 6.02-22 or higher.
NSMasterLSICIM	LSI CIM provider version 3.06 Important: Contact <www.lsilogic.com> web site to download the above versions. If not on-line, contact the Bull support team. Note: Not supported on Linux IA64 system.
NSMasterStoreWayFDA	StoreWay FDA SNMP Agent release included in the "iSM NEC Storage Manager" v 4.2e and higher.
NSMasterDD4A	DD4A version 2.6.3 and higher
NSMasterBVS	BVS version 4.0 and higher

Table 4. Management Server Add-Ons Operational Requirements

## Restrictions

### Windows

N/A

### Linux

N/A

---

## Installing NovaScale Master Server Add-Ons for Windows

### Prerequisites

To install **NovaScale Master Server Add-Ons** on Windows:

- The user must be a member of an Administrators group. The default administrator login is Administrator.
- The installation program requires the Internet Explorer WEB browser. Other browsers, such as Netscape or Mozilla, cannot be used to install NovaScale Master on Windows.
- Management Server Add-Ons are to be installed on the server dedicated to management.
- Acrobat Reader is required to view PDF versions of the NovaScale Master documentation.
- The free Server Add-ons are present on the NS Master CD-ROM, the others must be supplied by your Bull contact.

## Installing Free Management Server Add-Ons from the CD-ROM

Management Server Add-Ons, to be installed on the server dedicated to management, require the components indicated in chapter *Installation Requirements* and must be installed from the CD-ROM.

To install **Management Server**:

1. From the dedicated server, launch the installation program.
2. Log on as **Administrator**.
3. Insert the NovaScale Master or NovaScale Master Add-ons CD-ROM in the drive. The installation program is launched automatically and opens the **Welcome** page.

 **Note:**

If the installation does not start automatically, double-click **<CD-ROM drive> / setup.exe**.



Figure 7. Windows Installation - NovaScale Master Welcome Page

4. Click **Install Now** to open the **Install** page, which allows the selection of the required NovaScale Master component:
  - Management Server Add-Onsand provides the following information:
  - What to install?
  - What to do now?

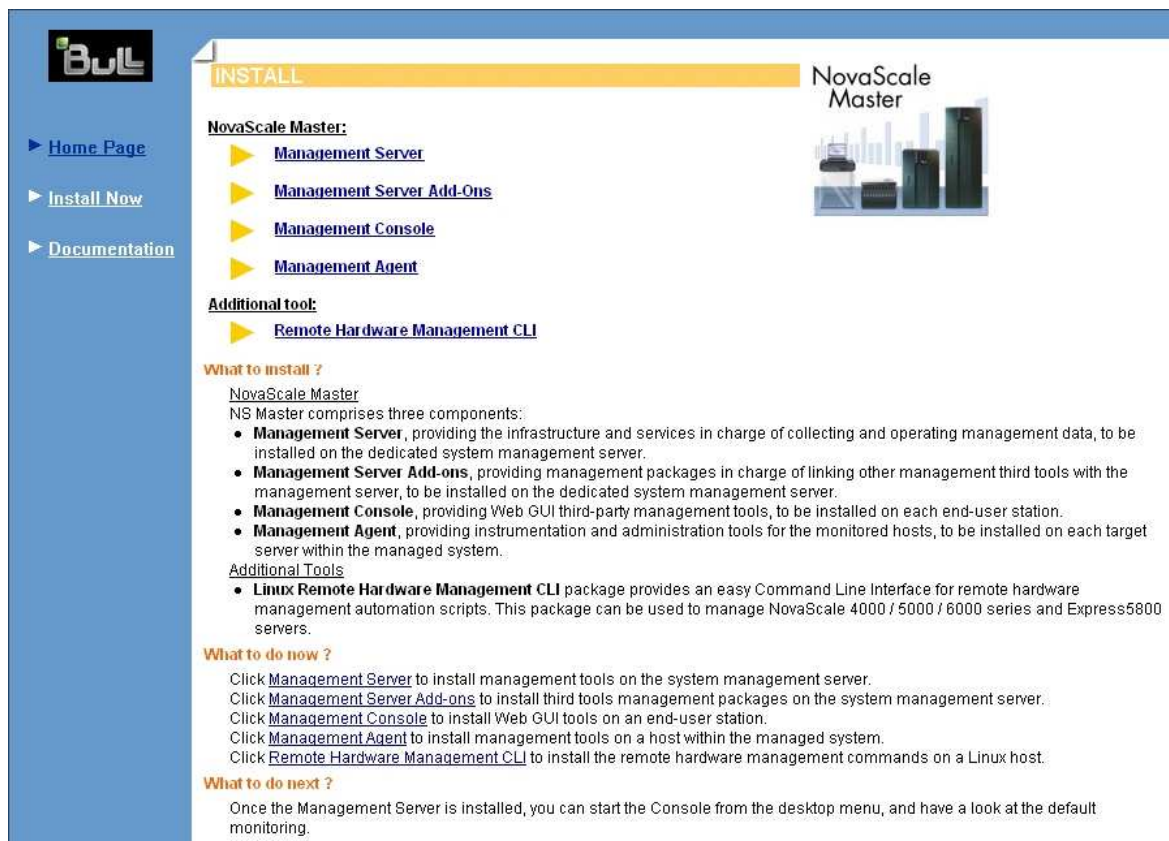

Figure 8. Windows Installation - NovaScale Master Welcome Page

5. Select **Install Management Server Add-Ons** and **Windows 32 bits** or **Windows 64 bits** operating system according to server type.

Click the selected Add-Ons **Install Now** link to install the **Server Add-Ons** package. The wizard prompts for a destination folder.

The default value can be changed if required. At the end of the installation process, Management Server Add-Ons components are automatically operational.

### Installing not Free Management Server Add-Ons packages

These are auto-extractible packages. To install a package, just launch it from any logical device.

**NSMaster<tierceTool>-5.0-x.exe**

### Uninstalling NovaScale Master Server Add-Ons Components



**Note:**

Uninstallation operations must be launched locally. Launching the uninstallation program removes all files and folders.

To uninstall NovaScale Master Add-Ons components:

1. From the Control Panel, launch **Add/Remove Programs**.
2. Select the required NovaScale Master Server Add-Ons components and click **Remove**.

## Upgrading to a New NovaScale Master Server Add-Ons Version

When upgrading to a new NovaScale Master Server Add-Ons version, the existing NovaScale Master Server Add-Ons environment that may have been customized is maintained.

NovaScale MasterServer Add-Ons are upgraded via the standard installation program.

### Note:

When you upgrade the NovaScale Master Management Server, you **MUST** upgrade previous release installed server add-ons to benefit from new improvements.

See the Release Notes for more details about specific add-on migration, where applicable. Installing free NovaScale Master Server Add-Ons for Linux

---

## Installing NovaScale Master Server Add-Ons for Linux

### Prerequisites

To install NovaScale Master Server Add-Ons on Linux:

The user must be logged as root.

The installation program requires the Mozilla WEB browser (Version >1.4.3 or Firefox):

If Mozilla is not installed, launch another WEB browser and open file:

```
<CD-ROM Mount point>/product /index.html
```

It is advised to uninstall the previous version of Mozilla before installing a new version. This operation will not delete bookmarks, histories, cookies and other information stored in the profile directory.

The Mozilla directory must be set in the root PATH environment variable. If a previous version of Mozilla has not been uninstalled, the Mozilla directory must be set at the beginning of the PATH variable.

- Management Server Add-Ons are to be installed on the server dedicated to management.
- Acrobat Reader is required to view PDF versions of the NovaScale Master documentation.
- The free Server Add-ons are present on the NS Master CD-ROM, the others must be supplied by your Bull contact.

### Installing Free Management Server Add-Ons from the CD-ROM

Management Server Add-Ons, to be installed on the server dedicated to management, require the components indicated in chapter *Installation Requirements* and must be installed from the CD-ROM.

To install **Management Server Add-Ons** from the CD-ROM:

1. From the dedicated server, launch the installation program.
2. Log on as **root**.
3. Insert the NovaScale Master CD-ROM in the drive.  
The CD-ROM filesystem is automatically mounted to one of the following directories:  
**/mnt/cdrom** or **/mnt/dvd** (Red Hat and Advanced Server distributions)  
**/media/cdrom** or **/media/dvd** (SuSE distribution).

4. Launch the following commands:

```
cd <CD-ROM mount point>  
./install.sh
```

The **install.sh** script automatically launches the Mozilla or Mozilla Firefox browser and opens the **Welcome** page.



Figure 9. Linux Installation - NovaScale Master Welcome Page

5. Click **Install Now** to open the **Install** page, which allows the selection of the required NovaScale Master component:
  - Management Server Add-Onsand provides the following information:
  - What to install?
  - What to do now?

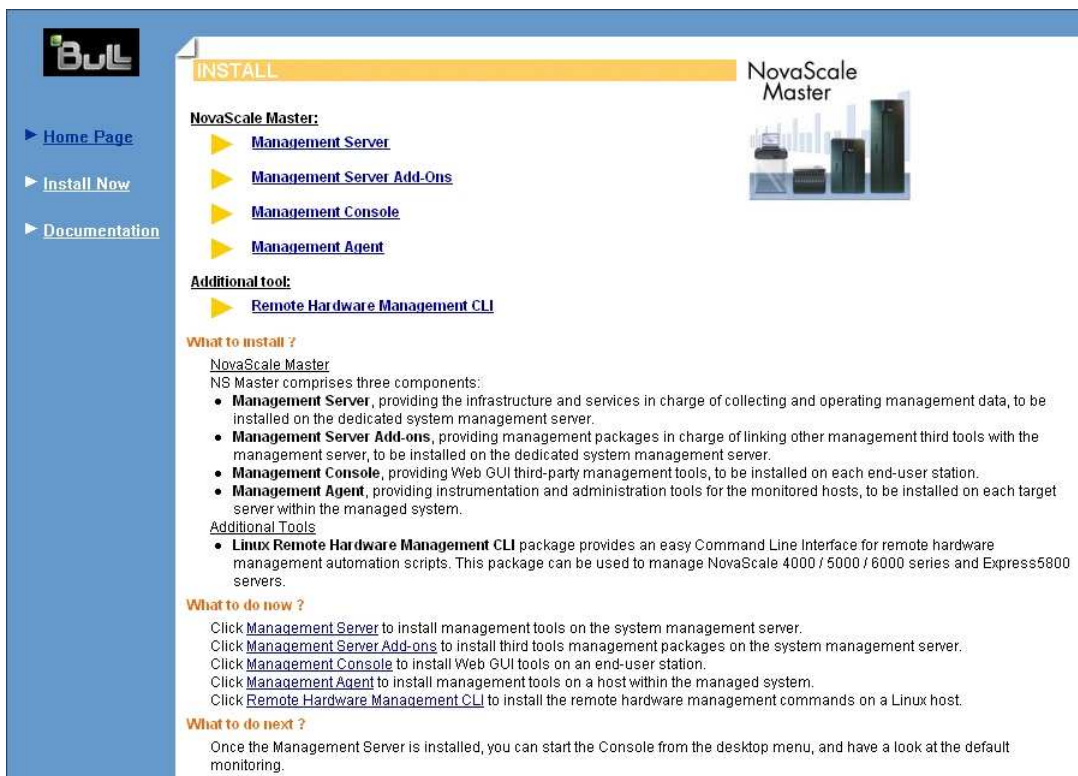

Figure 10. Linux Installation - Selecting NovaScale Master Components

6. Select Install Management Server Add-Ons.
7. Select the **Linux 32 bits** or **Linux 64 bits** operating system according to server type.
8. Install the selected **NovaScale Master Server Add-Ons** packages as described below.

```
cd <CD-ROM mount point>/product/mgtpack/NSMaster<toolname>/linux
rpm -Uvh NSMaster<toolname>-5.0-x.noarch.rpm
```

### Installing not Free Management Server Add-Ons packages

These are RPM packages. To install a package just launch it from any logical device.

```
rpm -Uvh NSMaster<tiercetool>-5.0-x.noarch.rpm
```

### Uninstalling NovaScale Master Server Add-On Components

1. Log on as **root**.
2. Launch the command :

```
rpm -e NSMaster<tiercetool>-5.0-x.noarch.rpm
```

### Upgrading to a new NovaScale Master Server Add-Ons Version

When upgrading to a new NovaScale Master Server Add-Ons version, the existing NovaScale Master Add-Ons environment that may have been customized is maintained.

NovaScale Master Add-Ons are upgraded via the standard rpm installation command:

```
rpm -Uvh NSMaster<toolname>-5.0-x.noarch.rpm
```

#### Note:

When you upgrade the NovaScale Master Management Server, you **MUST** upgrade previous release installed server add-ons to benefit from new improvements.

See the Release Notes for more details about specific add-on migration, where applicable.





---

## Chapter 3. Monitoring Configuration

Configuring NovaScale Master Monitoring consists mainly in specifying the parameters required for monitoring tasks. Most configuration tasks are performed via the NovaScale Master Configuration GUI (Graphical User Interface).

NovaScale Master Server Add-Ons extend the Monitoring configuration default rules the Administrator can customize.

- New monitoring categories and services.

---

### Overview

#### Configuration GUI

NovaScale Master provides a GUI to perform the main configuration tasks.

#### Starting the Configuration GUI

To start the Configuration GUI, either:

- From the NovaScale Master Console, click the  icon representing the Configuration GUI in the Administration zone (top right).
- Or click the **Configuration** link on the NovaScale Master Home Page, URL: **<http://<NovaScale Master server name>/NSMaster>**
- Or, from a WEB browser, go to the following URL: **<http://<NovaScale Master server name>/NSMaster/config/>**

---

### Monitoring Details

NovaScale Master Server Add-Ons delivers more default monitoring categories and services. These categories and services depend on the Operating System running on the host:

- services for Windows hosts will be applied to all hosts with a Windows operating system,
- services for Linux hosts will be applied to all hosts with a Linux operating system,
- services for hosts, independently of the Operating System, will be applied to all hosts.

The administrator can change the default-monitoring configuration by:

- **customizing services**, to define specific thresholds and monitoring properties or to modify the list of monitored hosts. A service can be customized to create one or more occurrences of this service with the same name. Each occurrence can have a different host list and different monitoring properties. For instance, if you do not want to monitor file systems in the same way on all Linux hosts, customize the **All** service in the **FileSystems** category.

#### Note:

The Administrator CANNOT modify the OS and/or model type of these monitoring services and categories, as internal tool semantic checks may reject such modifications.

- **cloning services**, to define new monitored elements. One or more services are created, with different names from the original names. All properties can be edited except the check command. For instance, to monitor a specific logical drive on a Windows system, clone the C service and modify the check command parameters,

- **customizing categories**, to restrict monitoring a whole category to a list of hosts,
- **creating a category**, to assign a set of cloned services to this category.

See the "NovaScale Master Administration's Guide" to see more details about configuration.

## Internal Storage Categories & Services

NovaScale Master Server Add-Ons provides the following default storage categories by Management Package:

### NSMasterGAMTT (LSI (Mylex) RAID Management)

#### Default categories & services independent of the type of OS

Targeted OS	Model	Category	Service	Check command
any	any	GAMTTraid	Status	check_gamtraid.pl
			Alerts	No check (SNMP trap receiver)

Table 5. GAMTT monitoring services

#### Notes:

1. This category is based on GAMTT management product from LSI. This tool and especially its SNMP interface is a requirement for the following GAMTTraid monitoring services. Verify this tool works on the targeted OS, if you want to monitor with it in NS Master.
2. This category is based on GAMTT management product from LSI. The previous (NS Master release 4.0) "MegaRAID" category is based on PowerConsolePlus management product from LSI. These two management products are functionally redundant but not compatible. So you can replace the "MegaRAID" category and its services by "GAMTTraid" category and services, if you replace PowerConsolePlus by GAMTT.

#### GAMTTraid Category

**Status** For NovaScale and Express5800 hosts with an LSI (or Mylex) SCSI RAID card managed by GAMTT (or GAM) management tool. This service checks the Host RAID status reported by the associated GAMTT SNMP agent.

**Alerts** For NovaScale and Express5800 hosts. When an alert is sent from the GAMTT SNMP agent, it is processed by the NovaScale Master server.

#### Note:

The **mlxraid.mib** mib is integrated in the NovaScale Master application.

#### Note:

Do not forget to configure the agent to send SNMP traps to the NovaScale Master server by adding the NovaScale Master server host address to the SNMP managers list of this agent.

### NSMasterLSICIM (LSI SCSI RAID Management)

#### Default categories & services independent of the type of OS

Targeted OS	Model	Category	Service	Check command
any	any	LsiCIM	RAIDStatus	check_LSICIM
			CTRLstatus	

Table 6. LSI CIM monitoring services

#### Note:

This category is based on the LSI CIM management product. This tool is a requirement for the

following LsiCIM monitoring services. Check that this tool works on the targeted OS, if you want to monitor with it in NS Master.

### LsiCIM Category

- RAIDstatus** For NovaScale and Express5800 hosts with an LSI SCSI RAID card managed by the LSI CIM management tool. This service checks the Host RAID status reported by the associated LSI CIM provider.
- CTRLstatus** For NovaScale and Express5800 hosts with an LSI SCSI RAID card managed by the LSI CIM management tool. This service checks the status of a specific RAID SCSI controller reported by the associated LSI CIM provider.

## External Storage Categories & Services

### NSMasterStoreWayFDA (StoreWay FDA Management)

Default categories & services independent of the type of OS:

Targeted OS	Model	Category	Service	Check command
any	any	StoreWayFDA	Status	check_NECFDA
			Alerts	No check (SNMP trap receiver)

Table 7. StoreWay FDA monitoring services

 **Notes:** This category is based on the StoreWay FDA SNMP agent. This SNMP interface is a requirement for the following StoreWayFDA monitoring services.

### StoreWayFDA Category

- Status** For StoreWay FDA hosts managed via its SNMP agent. This service checks the StoreWay FDA status reported by the SNMP agent.
- Alerts** For StoreWay FDA hosts. When an alert is sent from the StoreWay FDA SNMP agent, it is processed by the NovaScale Master Server.

 **Note:** The **Armg2\_4.mib** mib is integrated in the NovaScale Master application.

 **Note:** Do not forget to configure the agent to send SNMP traps to the NovaScale Master Server by adding the NovaScale Master Server host address to the agent's SNMP managers list.

## Bull Products Categories & Services

NovaScale Master Server Add-Ons provides the following default Bull products categories by Management Package:

### NSMasterBVS ("Bull Video Services" Management)

Default categories & services proposed for Linux hosts:

Targeted OS	Model	Category	Service	Check command
Linux	any	BullVideoServices	Streaming	check_BullVideoServices
			Recording	
			Datagrams	

Table 8. BullVideoServices

### BullVideoServices Category

- Streaming** For NovaScale Linux hosts acting as Bull video server. This service checks the status of the video streaming service.
- Recording** For NovaScale Linux hosts acting as Bull video server. This service checks the status of the video recording service.
- Datagrams** For NovaScale Linux hosts acting as Bull video server. This service checks the status of the video datagram errors.

## NSMasterDD4A ("Dynamic Domains For Applications" Management)

### Default categories & services proposed for Linux hosts

Targeted OS	Model	Category	Service	Check command
Linux	any	DynamicDomains	All	check_dd4a
			default	

Table 9. DD4A services

### DynamicDomains Category

- All** For NovaScale and Express5800 Linux hosts with Dynamic Domains management tool. This service dynamically checks global status reported by the associated webmin module for all defined Dynamic Domains.

 **Note:**

There is no need to reconfigure it to survey new defined Dynamic Domains.

- default** For NovaScale and Express5800 Linux hosts with the Dynamic Domains management tool. This service checks the status of the Dynamic Domain "default".

 **Note:**

When creating a new Dynamic Domain, clone statically this default monitoring service to survey the new dynamic domain.

## Internal Storage Check Commands

The following table lists the **check commands** used by the predefined activated services of NovaScale Master Add-Ons.

See also [Chapter 4 - Check Commands for Customizable Services](#), which describes the syntax of the check commands associated with the services that can be customized.

## NSMasterGAMTT (LSI (Mylex) SCSI RAID management)

### check\_gamttRAID (any OS) Nagios command

The configurable NS Master service check command syntax is:

```
check_gamttRAID!<community>!<port>!<timeout>!{ [-A {ALL|<Ct>}] | [-P {ALL|<Ct>.<Ch>.<Tg>}] | [-L {ALL|<Ct>.<Ldn>}] }
```

see *check\_gamttraid shell command*, on page 4-1 for parameters detail.

Default syntax for "GAMTTraid.Status" is:

```
Check_gamttRAID!public!161!60!-A ALL
```

## NSMasterLSICIM (LSI SCSI RAID Management)

### **check\_LSICIM (any OS) Nagios command**

The configurable NS Master service check command syntax is:

```
check_LSICIM! [<ctrlname>]
```

see *check\_LSICIM*, on page 4-3 for parameters detail.

Default syntax for "LsiCIM.CTRLstatus" is:

```
Check_LSICIM! 'ctrlname'
```

## External Storage Check Commands

### NSMasterStoreWayFDA (StoreWay FDA Management)

#### **check\_NECFDA (any OS) Nagios command**

The configurable NS Master service check command syntax is:

```
check=check_necfda! <community>! <port>! <timeout>
```

see *check\_NECFDA*, on page 4-5 for parameters detail.

Default syntax for "StoreWayFDA.Status" is:

```
check_necfda!public!161!60
```

## Bull Products Check Commands

### NSMasterDD4A ("Dynamic Domains For Applications" Management)

#### **check\_DynamicDomains (Linux OS) Nagios command**

The configurable NS Master service check command syntax is:

```
check_DynamicDomains! <{ALL | <DomainName>}
```

see *check\_DD4A shell command*, on page 4-6 for parameters detail.

Default syntax for "DynamicDomains.All" is:

```
Check_DynamicDomains!ALL
```

Default syntax for "DynamicDomains.default" is:

```
Check_DynamicDomains!default
```

### NSMasterBVS ("Bull Video Services" Management)

#### **check\_BVS (Linux OS) Nagios command**

The configurable NS Master service check command syntax is:

```
check_BVS! <serviceName>
```

see *check\_BVS shell*, on page 4-7 for parameters detail.

For instance, Default syntax for "BullVideoService.Streaming" is:

```
Check_BVS!Streaming
```



---

## Chapter 4. Check Commands for Customizable Services of Add-Ons

This chapter describes the usage of the check commands by customizable services.

 **Notes:** The ! character must be used to separate the monitoring server (Nagios) check\_command parameters in the service definition.

These commands are Linux commands. They run only under CYGWIN on Windows.

---

### Internal Storage Management

#### NSMasterGAMTT

##### check\_gamttRAID

check\_gamttRAID uses the following shell (PERL) command:

##### check\_gamttraid shell command

###### Usage

```
check_gamttraid -H <host> [-C <community>] [-p <port>] [-t <timeout>]
{ [-A {ALL|<Ct>}] | [-P {ALL|<Ct>.<Ch>.<Tg>}] | [-L {ALL|<Ct>.<Ldn>}] }
[-v <vl>] [-f <f>]
```

-H, --hostname <host>

Hostname or IP address of target to check

-C, --community <community>

SNMP community string (defaults to "public")

-p, --port <port>

SNMP port (defaults to 161)

-t, --timeout <timeout>

Seconds before timing out (defaults to Nagios timeout value)

-A, --adapter ALL | <Ct>

Controller board

-P, --physical ALL | <Ct>.<Ch>.<Tg>

Physical device addr

-L, --logical ALL | <Ct>.<Ldn>

Logical drive addr

-v, --verbosity <vl>

Verbosity level:

"0" None

"1" Adds the <CtrlModel> and the status of all controller boards filtered

-f, --format <f>

"0" Carriage Return in ASCII mode (\n)

"1" Carriage Return in HTML mode (<br>)

### Return code

"OK" (0), "WARNING" (1), "CRITICAL" (2), "UNKNOWN" (3)

"OK":

All "logical drives" and all "physical devices" run normally.

"WARNING":

At least one "logical drive" or one "physical device" is in a "WARNING" state.

"CRITICAL":

At least one "logical drive" or one "physical device" is in a "CRITICAL" state.

"UNKNOWN"

All other types of processing errors (bad parameter, no response, and so on...).



### Note:

In the case of multiple errors, the global state will be the worst one; "CRITICAL" > "WARNING" > "OK".

### Output

A string composed with a global state descriptor followed, if they exist, by error states of concerned component (controller, Logical Device, Physical Device).

#### global descriptor state:

The first line shows the global state. The syntax is:

```
GAMTT RAID [CT |PD |LD ]<GlobalStatus>
```

```
"CT " : if "-A".
```

```
"PD " : if "-P".
```

```
"LD " : if "-L".
```

#### state descriptor by controller

They may be present after the global state descriptor if an error exists.

The syntax is:

```
[ CT(Ct<Ct>) <CtrlModel> <CtrlStatus>
[ {LD(Ct<Ct> Nu<Ldn>) <LDType> <LDStatus>[ , ] ...} ]
[ {PD(Ct<Ct> Ch<Ch> Tg<Tg>) <PDType> <PDStatus>[ , ] ...} ]
...]
```

<GlobalStatus> worst detected status

<CtrlModel> controller model

<CtrlStatus> worst state detected for an element of this controller (LD and PD)

<Ct> controller number

<Ldn> "logical drive" number

<LDType> "logical drive" type: "RAIDx" or "JBOD"

<LDStatus> "logical drive" status

<Ct> controller number

<Ch> "channel" number

<Tg> target number

<PDType> "physical device" type: "Disk", "Processor", "Ctrl Channel", ...

<PDStatus> "physical device" status



### Examples:

1. If global state is "OK":

```
> check_gamttraid -H <host>
GAMTT RAID OK
>

> check_gamttraid -H <host> -P 0.0.1
GAMTT RAID PD OK
>

> check_gamttraid -H <host> -L 0.0
GAMTT RAID LD OK
>

> check_gamttraid -H <host> -v 1
GAMTT RAID OK
CT(Ct0) MegaRAID Ultra320-2x OK
CT(Ct1) DAC960FFX2 OK
CT(Ct2) MegaRAID Ultra320-2x OK
>

> check_gamttraid -H <host> -A 1 -v 1
GAMTT RAID CT OK
CT(Ct1) DAC960FFX2 OK
>
```

2. If global state is "CRITICAL" or "WARNING", only concerned elements are displayed:

```
> check_gamttraid -H <host>
GAMTT RAID CRITICAL
CT(Ct0) MegaRAID Ultra320-2x CRITICAL
PD(Ct0 Ch0 Tg1) Disk Dead
>

> check_gamttraid -H <host> -L 0.1
GAMTT RAID LD CRITICAL
CT(Ct0) MegaRAID Ultra320-2x CRITICAL
LD(Ct0 Nul) RAID5 Critical
>
```

3. If return code is "UNKNOWN":

```
> check_gamttraid -H <host>
GAMTT RAID UNKNOWN - snmp query timed out
>
```

## NSMasterLSICIM

### check\_LSICIM

check\_LSICIM uses the following shell (PERL) command:

#### check\_LSICIM shell command

##### Usage

```
check_LSICIM -H <host> [-C <ctrlname>]
```

-H, --hostname <host>

Hostname or IP address of target to check

-C, --ctrlname <ctrlname>

Name of the controller to check



##### Note:

The name of the controller must be protected with a quote if the name contains blank characters.

### Return code

"OK" (0), "WARNING" (1), "CRITICAL" (2), "UNKNOWN" (3)

"OK":

All "Controllers" run normally.

"WARNING":

At least one " Controllers" is in a "WARNING" state.

"CRITICAL":

At least one " Controllers" is in a "CRITICAL" state.

"UNKNOWN"

All other types of processing errors (bad parameter, no response, etc...).



### Note:

In the case of multiple errors, the global state will be the worst one; "CRITICAL" > "WARNING" > "OK".

### Output

A string indicates the state of mirroring followed, where applicable, by concerned component error states (controller, Logical Device, Physical Device).

If the GlobalStatus determined by the worst status of components is not OK, the state of the component is reported with the following format:

```
[CT(Ct<Ct>) <CtrlName> <CtrlStatus>
[{} LD(Ct<Ct> Nu<Ldn>) <LDType> <LDStatus>[, ] ...]]
[{} - PD(Ct<Ct> Ch<Ch> Tg<Tg>) <PDManufacturer> <PDModel> <PDStatus>[,
[{} PD(Ct<Ct> Ch<Ch> Tg<Tg>) <PDManufacturer> <PDModel> <PDStatus>[, ] ...]]
```

<Ct> controller number

<CtrlModel> controller model

<CtrlStatus> worst state detected for an element of this controller (LD and PD)

<Ldn> "logical drive" number

<LDType> "logical drive" type: IM

<LDStatus> "logical drive" status as reported by the LSI CIM provider

<Ch> "channel" number

<Tg> target number

<PDManufacturer>  
"physical device" manufacturer

<PDModel> "physical device" model

<PDStatus> "physical device" status as reported by the LSI CIM provider

### Examples:

```
$ ./check_LSICIM -H 172.31.50.71
: LSI SCSI storage - Integrated Mirroring not available -

LSI SCSI storage - Integrated Mirrored available -
CT(0) LSI 53C1030 CRITICAL
> LD(Ct0 Ch2 Tg0) IMVolume: Degraded Redundancy
- PD(Ct0 Ch3 Tg0) SEAGATE ST373454LC: Error

$ ./check_LSICIM -H 172.31.50.71 -C 'LSI SCSI1030 - 0'
> CT(0) LSI 53C1030 OK

$ ./check_LSICIM -H 172.31.50.71 -C 'LSI SCSI1030 - 0'
> CT(0) LSI 53C1030 CRITICAL
- PD(Ct0 Ch0 Tg0) MAXTOR ATLAS10K4_36SCA CRITICAL
```

---

## External Storage Management

### NSMasterStoreWayFDA

#### check\_NECFDA

check\_NECFDA uses the following shell (PERL) command:

#### check\_NECFDA shell command

##### Usage

```
check_necfda -H <host> [-C <community>] [-p <port>] [-t <timeout>] [-f <f>]
```

-H, --hostname <host>

Hostname or IP address of the target to check

-C, --community <community>

SNMP community string (defaults to "public")

-p, --port <port>

SNMP port (defaults to 161)

-t, --timeout <timeout>

Seconds before timing out (defaults to Nagios timeout value)

-f, --format <f>

"0" Carriage Return in ASCII mode (\n)

"1" Carriage Return in HTML mode (<br>)

```
check_necfda -help
```

-h, --help

Display help

```
check_necfda -version
```

-V, --version

Display version

##### Return code

"OK" (0), "WARNING" (1), "CRITICAL" (2), "UNKNOWN" (3)

##### Output

The first line shows the global state with the following format:

```
necfda <GlobalStatus>
```

<GlobalStatus> : Most severe state detected on a controller.

##### Examples:

1. If the global state is « OK »

```
> check_necfda -H <host>
necfda OK
>
```

2. If the global state is "CRITICAL" or "WARNING", only errors are displayed :

```
> check_necfda -H <host>
necfda CRITICAL
>

> check_necfda -H <host>
necfda WARNING
>
```

3. When the return code is "UNKNOWN":

```
> check_necfda -H <host>
necfda UNKNOWN - snmp query timed out
>

> check_necfda -H <host>
necfda UNKNOWN - no data received
>
```

---

## Bull Products Management

### NSMasterDD4A

#### check\_DynamicDomains

check\_DynamicDomains uses the following shell (PERL) command:

#### check\_DD4A shell command

##### Usage

```
check_DD4A -H <host> [-w ] [-D <domainName>]
```

-H, --hostname <host>

Hostname or IP address of target to check

-D, --domain ALL | <domainName>

ALL domains or a specific one: <domainName>

-w, --web

WEB HTML output format

##### Return code

"OK" (0), "WARNING" (1), "CRITICAL" (2), "UNKNOWN" (3)

"OK":

All "Dynamic Domains" run normally.

"WARNING":

At least one "Dynamic Domain" is in a "WARNING" state.

"CRITICAL":

At least one "Dynamic Domain" is in a "CRITICAL" state.

"UNKNOWN"

All other types of processing errors (bad parameter, no response, etc...).



#### Note:

In the case of multiple errors, the global state will be the worst one; "CRITICAL" > "WARNING" > "OK".

##### Output

A string with a global state descriptor followed, if they exist, by error states of the concerned component (controller, Logical Device, Physical Device).

If -D ALL or without -D parameter

The first line displays the defined Dynamic Domains number.

Then, only Dynamic Domains with issues are displayed with their status, their number of used CPUs, their CPU load (and the associated threshold) and their number of tasks.

#### **Note:**

The global state is not displayed textually, only the command return code contains this status information.

If `-D <domainName>`

The command output displays the defined Dynamic Domain name with its number of used CPUs, its CPU load (and the associated threshold) and its number of tasks.

Examples:

- `check_DD4A -H <host>`

or

- `check_DD4A -H <host> -D ALL`

```
4 Dyn.Domains.
```

```
- domain2 : WARNING
```

```
CPUs: 4 / 4, tasks: 70
```

```
load: 80% ( > 75% )
```

```
- domain3 : CRITICAL
```

```
CPUs: 4 / 4, tasks: 110
```

```
load: 100% ( > 75% )
```

- `check_DD4A -H <host> -D default`

```
default : OK
```

```
CPUs: 7 / 8, tasks: 37
```

```
load: 0.56% ( < 75% )
```

## NSMasterBVS

### check\_BVS

`check_BullVideoServices` uses the following shell (PERL) command:

#### check\_BVS shell command

##### Usage

```
check_BVS -H <host> -S {Streaming|Recording|Datagrams}  
[{-p <period>} | {-l <begin> -t <end> }] [-w]
```

`-H, --hostname <host>`

Hostname or IP address of target to check

`-S, --service Streaming|Recording|Datagrams`

`-p, --period <period> | -l <begin> -t <end>`

indicates to the Bull Video Server the period in seconds to calculate the average values

`-w, --web`

WEB HTML output format

##### Return code

"OK" (0), "WARNING" (1), "CRITICAL" (2), "UNKNOWN" (3)

"OK":

"Bull Video Server" runs normally.

"WARNING":

"Bull Video Server" is in "WARNING" state.

"CRITICAL":  
"Bull Video Server" is in "CRITICAL" state.

"UNKNOWN"  
All other type of processing errors (bad parameter, and so on...).

The BVS state "UNREACHABLE" (*Bull Video Server* is in " UNREACHABLE " state (daemon not started, communication timeout, ...)).will be transformed to Nagios "UNKNOWN" status.

The status values (OK, WARNING, CRITICAL) are fixed by the video server himself following criterias indicated by a Bull Video Server administrator.

### Output

The following information is displayed. Average values are calculated using the value specified by the `polling interval' textbox from the service configuration screen. The default value is 1 min. A modification of this value will be automatically taken into account by the check\_BVS plugin.

### `Streaming' service

Status: global status of `Streaming' service

Channels: number of channels used for streaming (average)

Rate: average rate in MB/s

Load : percentage of disk rate in relation to a value declared on BVS server

### Example:

```
check_BVS -H <host> -S Streaming
```

```
Status: OK  
channels: 17.00,  
rate (MB/s): 38.84,  
load: 12.69 %
```

### `Recording' service

Status: global status of `Recording' service

Channels: number of channels used for recording (average)

Rate: average rate in MB/s

Load : percentage of disk rate in relation to a value declared on BVS server.

### Example:

```
check_BVS -H <host> -S Recording
```

```
Status: OK  
channels: 7.00,  
rate (MB/s): 3.84,  
load: 7.69 %
```

### `Datagrams' service

Status: global status of `Datagram' service

Nb of late dg: number of UDP datagram's sent late per second (average)

Avg late value: average delay value in ms. A delay value between 0 and 10 ms is considered as a normal value.

Nb of deleted dg : number of deleted UDP datagrams per second (average).

**Example:**

```
check_BVS -H <host> -S Datagrams
Status: OK
nb of late dg: 128.67,
avg late value: 1.03 ms,
nb of deleted dg: 3.08
```

**Service Inaccessible**

In case of inaccessible services only the RC will be displayed.

**Example:**

```
check_BVS -H <host> -S <service>
Status: UNREACHABLE
```





## Spaces

ServiceStatus, 3-2, 3-3

## A

alerts, 1-1

Alerts Service, 3-2, 3-3

All Service, 3-4

Arm2\_4.mib, 3-3

## B

Bull Video Services, 1-7

BullVideoServices Category, 3-4

BVS, 1-7

## C

category, default, 3-3

check command

list, 3-4

syntax, 4-1

check\_BVS command, 4-7

check\_DynamicDomains command, 4-6

check\_gamttRAID command, 4-1

check\_LSiCIM command, 4-3

check\_NECFDA command, 4-5

CIM, 1-5

commands

check\_BVS, 4-7

check\_DynamicDomains, 4-6

check\_gamttRAID, 4-1

check\_LSiCIM, 4-3

check\_NECFDA, 4-5

ping, 1-1

CTRLstatus Service, 3-3

## D

Datagrams Service, 3-4

DD4A, 1-6

default Service, 3-4

Disk Space, Requirements, 2-1

Dynamic Domains For Applications, 1-6

DynamicDomains Category, 3-4

## F

FDA, 1-6

## G

GAM, 1-3

GAMTT, 1-3

GAMTTraid Category, 3-2

GUI

configuration tasks, 3-1

starting, 3-1

GUI Configuration, 3-1

## H

Hardware Manager, 1-2

## I

Installation

Requirements, 2-1

Windows, 2-2

Installation (Linux), 2-5

## L

LSI 22320 chip, 1-5

LSI CIM, 1-5

LSI MegaRAID, 1-3

LsiCIM Category, 3-3

## M

MegaRAID, 1-3

megaraid.mib, 3-2

Memory, Requirements, 2-1

MIB, 1-2

Monitoring Configuration, 3-1

## N

notifications, 1-1

NSMasterBVS, 1-7

NSMasterDD4A, 1-6

NSMasterGAMTT, 1-3

NSMasterLSiCIM, 1-5

NSMasterStoreWayFDA, 1-6

## O

Operating Systems, 2-1

## P

ping command, 1-1

## R

RAIDstatus Service, 3-3

Recording Service, 3-4

Restrictions, 2-2

## S

Server Add-On, 1-3

Service, 1-2

Cloning, 3-1

Customization, 3-1

SNMP traps, 1-2

Storage Manager, 1-2

StoreWay FDA, 1-6

StoreWayFDA Category, 3-3

Streaming Service, 3-4

## T

thresholds, 1-1

## U

URL, NovaScale Master main page, 3-1

## V

Video Services, 1-7



## Technical publication remarks form

<b>Title :</b>	NOVASCALE NovaScale Master Server Add-ons Installation and Administrator's Guide
----------------	--

<b>Reference:</b>	86 A2 95ER 01
-------------------	---------------

<b>Date:</b>	October 2006
--------------	--------------

### ERRORS IN PUBLICATION

--

### SUGGESTIONS FOR IMPROVEMENT TO PUBLICATION

--

Your comments will be promptly investigated by qualified technical personnel and action will be taken as required.  
If you require a written reply, please include your complete mailing address below.

NAME : \_\_\_\_\_ Date : \_\_\_\_\_

COMPANY : \_\_\_\_\_

ADDRESS : \_\_\_\_\_

Please give this technical publication remarks form to your BULL representative or mail to:

Bull - Documentation Dept.  
1 Rue de Provence  
BP 208  
38432 ECHIROLLES CEDEX  
FRANCE  
info@frec.bull.fr

# Technical publications ordering form

To order additional publications, please fill in a copy of this form and send it via mail to:

**BULL CEDOC**  
**357 AVENUE PATTON**  
**B.P.20845**  
**49008 ANGERS CEDEX 01**  
**FRANCE**

**Phone:** +33 (0) 2 41 73 72 66  
**FAX:** +33 (0) 2 41 73 70 66  
**E-Mail:** [srv.Duplicopy@bull.net](mailto:srv.Duplicopy@bull.net)

Reference	Designation	Qty
-- -- [ ]		
-- -- [ ]		
-- -- [ ]		
-- -- [ ]		
-- -- [ ]		
-- -- [ ]		
-- -- [ ]		
-- -- [ ]		
-- -- [ ]		
-- -- [ ]		
-- -- [ ]		
-- -- [ ]		
[ ] : The latest revision will be provided if no revision number is given.		

NAME: \_\_\_\_\_ Date: \_\_\_\_\_

COMPANY: \_\_\_\_\_

ADDRESS: \_\_\_\_\_

PHONE: \_\_\_\_\_ FAX: \_\_\_\_\_

E-MAIL: \_\_\_\_\_

**For Bull Subsidiaries:**

Identification: \_\_\_\_\_

**For Bull Affiliated Customers:**

Customer Code: \_\_\_\_\_

**For Bull Internal Customers:**

Budgetary Section: \_\_\_\_\_

**For Others: Please ask your Bull representative.**



**BULL CEDOC**  
**357 AVENUE PATTON**  
**B.P.20845**  
**49008 ANGERS CEDEX 01**  
**FRANCE**

REFERENCE  
**86 A2 95ER 01**